

ORIGINAL INSTRUCTIONS

#004-965

GraverMach® AT

OPERATION AND MAINTENANCE MANUAL

**READ THIS MANUAL ENTIRELY
BEFORE CONNECTING TO POWER.**

Damage not covered by the warranty may result from not following the instructions and maintenance in this manual.

NOTICE

 This engraving system requires clean, dry, oil-free air. An oil-free compressor is recommended for use with this system. For any oil-type compressors, an oil-removal filter (coalescing type) in the air supply line to this engraving system **MUST BE INSTALLED AND IN USE.**

**OIL OR WATER CONTAMINATION
IS NOT COVERED BY WARRANTY.**

For help with ordering or installing an oil-removal filter, or for guidance with operation or maintenance, please contact GRS or an authorized GRS dealer.

To send a request for assistance via electronic formats, e-mail support@glendo.com or visit:

<http://www.grstools.com/customerservice/>

Important notes are **highlighted in yellow** or **marked in red**.

Manual Contents

Important Notice For Operators	1
Required Equipment & Important Notes	2
Introduction, Unpacking The Unit	4
Setup & Connections	6
Mount & Connect Air Filter, Connect Foot Throttle, Connect Handpiece(s), Using an Air-Driven Rotary Handpiece, Connect Electrical Power	
Operation	8
Strokes Per Minute (SPM), Fine Adjustments for Handpiece Operation, Handpiece Adjustment Troubleshooting, Foot Throttle Operation, Handpiece Operation, Adjustments Using the Bias Control	
Airtact Operation	12
Connecting and Operating, Airtact Air Pressure Adjustments	
Maintenance	14
Handpiece, Foot Throttle, GRS Ultra 850 Rotary Handpiece	
Important Notices	15
GRS Progressive Foot Throttle Owners, Air Contaminants & Water Accumulation	
Palm Pad Fine Adjustment	16
Type-E Palm Pads, Forming the Rubber Control Flap	
Service & Repair	17
Parts Lists	18
Wiring, Hose Diagrams	26
Warranty	28

**READ THIS MANUAL ENTIRELY
BEFORE CONNECTING TO POWER.**

Damage not covered by the warranty may result from not following the instructions and maintenance in this manual.

IMPORTANT NOTICE FOR OPERATORS

Read this manual thoroughly before operation. The manufacturer is not responsible for injury resulting from improper operation or when used by untrained operators.



Do not modify this equipment or remove warning labels. Modifications can increase risks to the operator. Do not use this equipment if it is damaged. This equipment allows the use of small sharp cutting tools that can break suddenly. Always wear eye protection appropriate for each application, and protect hands from sharp edges.

Like other power tools, this device exposes the operator to mechanical vibration. If any user experiences discomfort, pain, numbness, aching, etc., in their hands, fingers, arms, or related joints, discontinue use and consult with an appropriate health professional.

Although this equipment does not generate dust itself, the tools used in the handpieces may do so. When sharpening tools, the user should take appropriate steps to avoid dust inhalation. Certain tool materials generate harmful dust while being ground or sharpened.

The proper use of this equipment does not generate significant or harmful noise emissions.



FOR PROPER OPERATION, THIS SYSTEM REQUIRES:

- Included 24-volt power converter connected to a properly grounded electrical power outlet

- Clean, dry, oil-free air provided by an air compressor

- A compatible GRS pneumatic handpiece

- A graver or similar tool

- A clean, sturdy work surface with adequate lighting

- Workholding device or material

READ THIS MANUAL ENTIRELY BEFORE CONNECTING TO POWER.

Damage not covered by the warranty may result from not following the instructions and maintenance in this manual.



REQUIRED EQUIPMENT & IMPORTANT NOTES

- **Included 24-volt power converter**

 **USE ONLY THE SUPPLIED 24-VOLT POWER CONVERTER.** The included power converter may be connected to any properly grounded single-phase source of AC power within a voltage range of 100 to 240 V, 50 or 60 Hz. If necessary, use the supplied grounded 2-prong plug adapter or other suitable adapter. The power converter must be used with a suitable grounded electrical system. Using it with an ungrounded system could expose the equipment to electrical damage. Do not use older generation power converters. If a replacement is needed, contact GRS or an authorized GRS dealer to order #022-987.

 **DO NOT OPERATE THE MACHINE WITHOUT A COMPRESSED AIR SUPPLY.** Compressed air not only provides the handpiece with power, it lubricates internal components including the rotary air valve. Do not add oil or any lubricant to the compressed air supply.

- **A compatible GRS pneumatic handpiece**

All GRS Standard Handpieces and GRS Airtact Handpieces are compatible with this system. **DO NOT USE SYSTEM 3 OR GRAVERMEISTER HANDPIECES.** Please contact GRS or an authorized GRS dealer for a complete list of compatible handpieces.

- **A graver or similar tool**

 A properly sharpened graver or similar tool is required to cut through the surface of metal and other materials; use with care. **The dust created while sharpening some tool materials may present a health risk.** Please contact GRS or an authorized GRS dealer for a list of available gravers and tools.

REQUIRED EQUIPMENT & IMPORTANT NOTES *(continued)*

- **Clean, dry, oil-free air from an air compressor**

 **Oil-free compressors are ALWAYS RECOMMENDED.** When using an oil-lubricated compressor, install an oil-removal filter (coalescing type – GRS #004-579 or equivalent) in the air supply line to this engraving system. Damage due to oil or water contamination IS NOT COVERED BY WARRANTY. Even slight amounts of oil can damage internal parts and cause erratic handpiece operation. The supplied final filter is not capable of removing large amounts of water, oil, or contaminants. See *Setup & Connections* for mounting the supplied air filter to engraving system.

 **If compressed air supply has excessive water, oil, or contaminants, an additional filter/water trap and oil-removal filter (coalescing type) must be installed ahead of the engraving system.**

GraverMach® AT requires a compressed air supply with minimum pressure 45 psi (3 bar) and maximum pressure 120 psi (8 bar). The compressed air supply must have a minimum flow capacity of 1.4 CFM [ft³/min] or 40 LPM [L/min]. To ensure a stable compressed air supply, the user should consider an additional air regulator to adjust the air pressure to 45-60 psi (3-4 bar) before it enters the GraverMach®.

- **A sturdy surface with adequate lighting**

Make use of a heavy workbench or suitable solid furniture to support this equipment, workpiece, and any additional equipment and supplies. Adequate lighting allows clear sight, and may help prevent accidents and reduce fatigue.

Placement of this engraving system on the bench is solely user preference and may be determined by left or right hand use during operation.

- **Workholding device or material**

For best results, using a workholding device or material is highly recommended. Properly secure the workpiece to ensure user safety and to guard the piece from damage while working. GRS manufactures several sizes and types of workholding devices, such as the MagnaBlock, Positioning Vise, MicroBlock vise, Thermo-Loc material, and the BenchMate™.

**DO NOT OPERATE ENGRAVING SYSTEM
WITHOUT AN ACTIVE AIR SUPPLY CONNECTED.**

The air supply lubricates the rotary valve as the air passes through the system. No additional lubrication is required.

FIG. 1 • GraverMach® AT Overview

Front View



Back View



GraverMach® AT FIG. 1 Diagram

- A. Airtact air pressure gauge
- B. Airtact air pressure control knob
- C. Power on/off button
- D. Bias control knob
- E. Primary air pressure gauge
- F. Primary air pressure control knob
- G. Handpiece selector knob (for J and K)
- H. Strokes Per Minute (SPM) dial
- I. Airtact hand/foot control selector knob
- J. Airtact Handpiece twist-lock fittings
- K. Standard Handpiece push-to-connect fittings
- L. Auxiliary air open/close knob
- M. Air supply input push-to-connect fitting
- N. Air filter
- O. Air filter bowl drain knob
- P. Air filter output push-to-connect fitting
- Q. Air filter input push-to-connect fitting
- R. Foot Throttle push-to-connect fitting
- S. Rubber grommet for stabilizer screw and washer storage—See **UNPACKING THE UNIT**
- T. Auxiliary Handpiece push-to-connect fitting
- U. 24-volt power receptacle
- V. Motor mount assembly stabilizer screw
- W. Reservoir drain plug
(drain located in bottom of base)



INTRODUCTION

The GraverMach® AT is an engraving system engineered and manufactured under the GRS Tools line of products by Glendo Corporation in the United States of America. This system is designed for assistance in creating unique works in metal, stone, wood, ivory, and many other materials.



UNPACKING THE UNIT

IMPORTANT SHIPPING NOTE



When unpacking a new GraverMach® AT, notice the screw protruding from the bottom of the machine (FIG. 1.V). This screw is holding the motor mount assembly to protect it from damage during shipping. Remove screw before operation. Use a 7/16" wrench / socket or an adjustable-end wrench to remove screw and washer, then store both by inserting into the rubber grommet located on the back (FIG. 1.S), as shown in the illustration.



For any shipping or transport of this unit, the screw and washer **MUST BE REPLACED** at the bottom of the unit to prevent damage to the motor mount assembly while in transit.



NEVER OPERATE WHILE ON SIDE. Always use the system in a vertical position (FIG. 1).

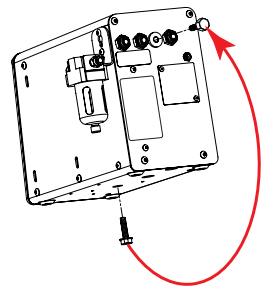
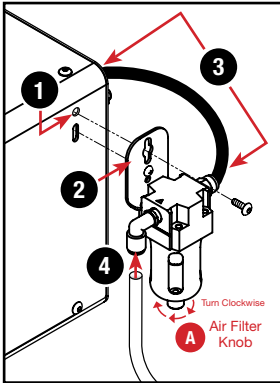

FIG. 2 • Mounting Air Filter to Side



A Drain water from filter daily. Turn knob clockwise (from top view) to open. Drain. Turn knob counter-clockwise to close valve.

1. Remove top screw from hole.
2. Place screw through top hole on air filter bracket. Tighten screw. Lower screw keeps filter from swinging freely; do not tighten or remove.
3. Power off system and air supply. Connect supplied short black hose (#044-229) to straight fitting on filter. Connect other end to "Air Input" fitting.

To mount elsewhere, use supplied longer black hose (#044-069) — see page 18.

4. Connect hose from air supply to filter fitting marked "N↑".

NOTE: If air supply hose is larger than 1/4" (6.35 mm) OD, either replace the push-to-connect fitting with the included barbed fitting and attach the air supply hose or purchase a reducer to decrease the OD to 1/4" (6.35 mm).

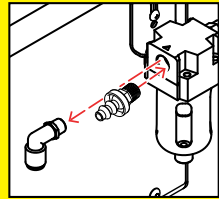
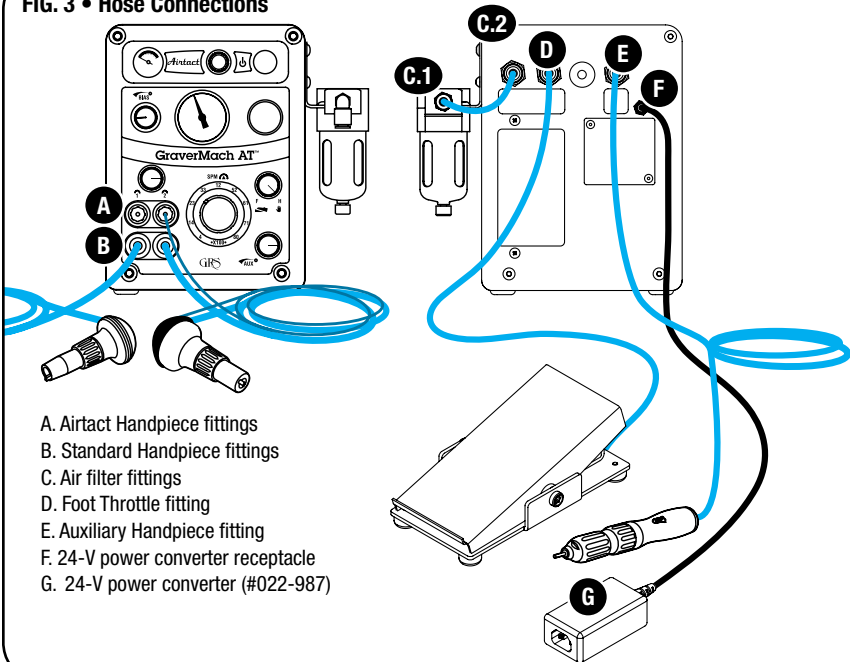

FIG. 3 • Hose Connections



- A. Airtact Handpiece fittings
- B. Standard Handpiece fittings
- C. Air filter fittings
- D. Foot Throttle fitting
- E. Auxiliary Handpiece fitting
- F. 24-V power converter receptacle
- G. 24-V power converter (#022-987)

SETUP & CONNECTIONS

MOUNT & CONNECT AIR FILTER

Mount air filter in a location where the air filter may be drained daily (see FIG. 2.A). Refer to FIG. 2 for instructions on mounting the air filter to side of system.

Power off engraving system and air supply. Insert appropriate hose (see FIG. 2.3) into the fitting until the hose stops and is secure. Power on engraving system and air supply to check for leaks and improper connections; air should not escape through any hose or fitting. If air leaks, power off system and air supply. Locate leaks and correct any improper connections. To disconnect from a push-to-connect fitting, press in on the orange ring while gently pulling out the hose.

CONNECT FOOT THROTTLE

Place foot throttle on the floor in a convenient position. Extend throttle hose to back of system (FIG. 3.D) to insert into fitting marked “THROTTLE CONNECTION”. The hose should not be pinched or kinked. **NOTE: The foot throttle varies handpiece power by controlling the amount of air that flows from the handpiece. While the throttle is depressed, it is normal for air to be released. The user may hear the air being released at times during operation.**

CONNECT HANDPIECE(S)

Two handpieces may be connected; only one handpiece can be in operation at any time. Each Standard Handpiece uses a single “B” push-to-connect fitting (FIG. 3.B); each Airtact Handpiece simultaneously uses one “A” twist-lock fitting (FIG. 3.A) and one “B” push-to-connect fitting (FIG. 3.A and B).

Connect desired handpiece(s) accordingly. The handpiece selector knob above the fittings allows use of either handpiece 1 or handpiece 2 (FIG. 1.G). **NOTE: The handpiece selector knob should stop completely when turned to either side, with the line on the knob parallel to the bench top or floor.**

USING AN AIR-DRIVEN ROTARY HANDPIECE

The auxiliary push-to-connect fitting (FIG. 3.E) is a straight flow air port that is limited to 40 psi (2.7 bar) maximum. This is the fitting for a rotary handpiece or other pneumatic tool. The knob is a twist-open/twist-close valve on the front of system (FIG. 1.L).



DO NOT EXCEED 35 psi (2.4 bar) when using the GRS Ultra 850 Rotary Handpiece.

CONNECT ELECTRICAL POWER



DO NOT OPERATE ENGRAVING SYSTEM WITHOUT AN ACTIVE AIR SUPPLY CONNECTED.

Insert the converter cord into receptacle on engraving system (FIG. 3.F and G). Connect the electrical power cord into the 24-volt power converter. Connect the 3-prong power cord into a properly grounded power outlet, using adapters as needed. See pages 2-3 for details.

OPERATION

STROKES PER MINUTE (SPM)

Stroke speed is a matter of personal preference and experience. The SPM dial (FIG. 4.C) settings are approximate and range from 400–8,000 SPM.

Lower speeds are used for stippling, matting, and similar techniques. Mid-range speeds are used for maximum-power tasks. Higher speeds are used for fine cuts and finishes. Experiment with the settings to better understand how the SPM relates to technique.

FINE ADJUSTMENTS FOR HANDPIECE OPERATION

PROPERLY ADJUSTING THE ENGRAVING SYSTEM IS THE SINGLE MOST IMPORTANT OPERATION TO LEARN. Each handpiece has a normal SPM range. Operating outside this range can produce erratic results.

SPECIAL NOTE: When powered on, the system pushes a small amount of air through the electrically-controlled air solenoid valve. When powered off, the system seals the valve, making a “pop” and “hiss” sound. This allows the system to be powered off while the air compressor remains on—without loss of air in the compressor tank.

- Power on the air compressor and allow tank to fill. **Wait for the compressor to cycle off.**
- Power on the GraverMach® AT. **Turn the bias control knob clockwise until closed.** Turn the handpiece selector knob to choose connected handpiece. Turn the hand/foot selector control knob to select “foot” control. **See *Airtact Operation* for using “hand” control.**
- Turn the SPM dial (FIG. 4.C) to 2300. Turn the primary air pressure control knob (FIG. 4.B) clockwise until the air pressure gauge displays 5 psi (0.4 bar).

- Hold the selected handpiece vertically near either ear as shown in FIG. 5.
- **WITHOUT operating the throttle,** slowly increase the air pressure until the handpiece begins to buzz. The handpiece will vibrate, then knock, as the pressure increases. Stop adding air pressure immediately after the knocking stops. This is the perfect air pressure operating range for the selected handpiece model.

See chart on page 9 for an alternative adjustment method.

FIG. 4 • Primary Control Knobs

- A. Bias control knob
- B. Primary air pressure control knob
- C. Strokes Per Minute (SPM) dial

Make sure the bias control knob is closed before adjusting the machine.

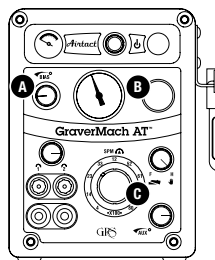

FIG. 5



Alternatively, the settings in the chart may be used for adjusting the selected handpiece; this method is not as precise. Set the SPM dial and the air pressure control knob to the *Recommended Initial Setting* for the selected handpiece.

HANDPIECE FINE ADJUSTMENT SETTINGS

Handpiece	Item Number	Type	Normal Operating Range <i>Strokes Per Minute</i>	Normal Air Pressure Range <i>psi (bar)</i>	Recommended Initial Setting	
					Strokes Per Minute	Air Pressure <i>psi (bar)</i>
Magnum	004-940		800-3400	18-22 psi (1.2-1.5 bar)	2400	20 psi (1.4 bar)
901	004-901, 004-910	Standard	1400-4000	17-22 psi (1.2-1.5 bar)	2400	19 psi (1.3 bar)
		Fine	1400-4000	12-15 psi (0.8-1.0 bar)	2400	13 psi (0.9 bar)
Monarch	004-921, 004-926	Standard	2000-5000	10-13 psi (0.7-0.9 bar)	3000	11 psi (0.8 bar)
		Fine	2000-5000	6-8 psi (0.4-0.6 bar)	3000	7 psi (0.5 bar)
Maestro MX	004-909		600-3200	18-22 psi (1.2-1.5 bar)	2200	20 psi (1.4 bar)
Maestro EX	004-905		800-3600	17-22 psi (1.2-1.5 bar)	2200	19 psi (1.3 bar)
Maestro	004-947		2000-5000	10-13 psi (0.7-0.9 bar)	3000	11 psi (0.8 bar)
QC 720	004-720		400-3000	18-26 psi (1.2-1.8 bar)	1600	22 psi (1.5 bar)
QC 710	004-710		800-3000	20-24 psi (1.4-1.7 bar)	1800	21 psi (1.4 bar)
610 Hammer	004-610, 004-609		800-3000	20-24 psi (1.4-1.7 bar)	1800	21 psi (1.4 bar)
QC 801	004-801, 004-810	<i>(obsolete)</i>	1400-4000	20-24 psi (1.4-1.7 bar)	2400	22 psi (1.5 bar)
506 Large	004-506	<i>(obsolete)</i>	400-3000	18-26 psi (1.2-1.8 bar)	1600	22 psi (1.5 bar)
508 Standard	004-508	<i>(obsolete)</i>	800-3000	18-22 psi (1.2-1.5 bar)	2000	20 psi (1.4 bar)

OPERATION *(continued)*

HANDPIECE ADJUSTMENT TROUBLESHOOTING

The system will be difficult to control if the air pressure or SPM is incorrect. Use the lowest air pressure setting to provide proper operation; do not set the air pressure higher than needed.

- Handpiece vibrates or knocks without using the Foot Throttle: air pressure is too low; increase to proper air pressure.
-
- Handpiece power decreases at full throttle: air pressure is too low or the SPM is too high; reset pressure or SPM.
-
- Handpiece does not operate within 3/8" (9.525 mm) of depressing foot throttle: air pressure is too high; decrease to proper air pressure.
-

Make fine adjustments in air pressure or SPM until proper operation is attained. The handpiece will operate smoothly and predictably once adjusted properly. With more experience, experiment with variations in air pressure and SPM to suit preferences.

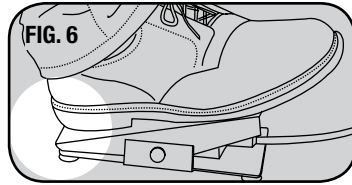

FOOT THROTTLE OPERATION

For foot throttle operation, set the engraving system to "foot" control as follows.

- Set the hand/foot control selector knob to the "foot" control position (FIG. 1. I).
-
- Place foot on throttle as shown in FIG. 6, with heel completely on the Foot Throttle and not on the floor.
-
- Before depressing foot throttle, position handpiece and tool properly. The tool should rest firmly on the material surface before operating the foot throttle.
-

After handpiece is adjusted properly, depress the foot throttle to activate the handpiece. To increase power when cutting deeper, depress the Foot Throttle as needed to increase handpiece power. It may take practice to coordinate foot action with the need for more power.

Rely on increasing the power provided by the foot throttle to the handpiece instead of manually pushing the handpiece through the cut. Manual pushing is an incorrect use of the handpiece and can result in the tool slipping.

At the start of the cut, smoothly increase power; as more power is needed, depress the foot throttle more. As the cut reaches the end, gradually reduce foot throttle pressure and quickly guide the graver up and out.

OPERATION *(continued)*

HANDPIECE OPERATION

Unlike traditional or push engraving where a firm grip and manual forward force is required, the GRS pneumatic handpiece requires only a light grip and guidance.

Relax, allowing the engraving system to move the tool forward and through the material with guidance. Most graver slips are due to manual hand pushing and an overly-firm grip on the handpiece.

A tight grip actually lessens impact power. For heavy work, decrease grip while increasing power with the foot throttle; an increasingly relaxed grip will increase the power. However, do not lose control while guiding the tool.

For general cutting techniques, position the handpiece as in FIG. 7.A; this is similar to holding a dinner knife. For stippling, hammering, or similar techniques, position the handpiece as in FIG. 7.B; this is similar to holding a pencil.

For hammering work, press the hammer tip down firmly to the material surface and then operate the foot throttle. This system is not like a flexible-shaft hammer; do not operate the hammer tool by holding the tip slightly above the surface. Use just enough downward pressure to keep the hammer in place while working.

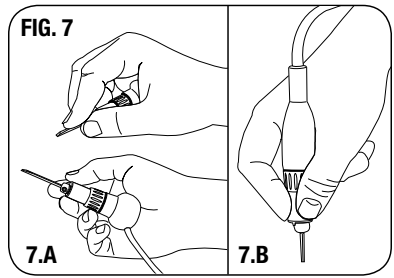

ADJUSTMENTS USING THE BIAS CONTROL

Use the bias control to adjust the starting position of the foot throttle. This feature may be useful for fine detail work such as bulino engraving. Open the bias control fully to activate the handpiece without depressing the foot throttle. This feature may be useful for stippling or hammering.

- Turn the primary air pressure control knob (FIG. 4.B) to add 1-2 psi (0.07-0.14 bar) air pressure to the current setting.
- Turn the bias control (FIG. 4.C) slightly to open the bias valve, just until the handpiece is activated; then slowly close the bias valve when the handpiece stops stroking. Note the foot throttle requires less pressure to activate the handpiece.

AIRTACT OPERATION

Comparison of Standard and Airtact Handpieces

Standard Handpiece: Throttle operated by pressure applied to Foot Throttle (not shown).



Airtact Handpiece: Throttle operated by pressure applied to Palm Pad.



CONNECTING AND OPERATING

The GRS Airtact touch-control system is integrated into this engraving system, adding the ability to use hand-controlled throttle. A Standard Handpiece will not operate as an Airtact Handpiece; it may only be operated by the foot throttle.

However, the knob on a Standard Handpiece can be replaced with an Airtact-ready knob for hand-controlled throttle. Additionally, the Standard Handpiece may be modified with the addition of a barrel-mounted Thumb / Finger Touch Element for hand-controlled throttle.

FIG. 8 • Airtact Operation

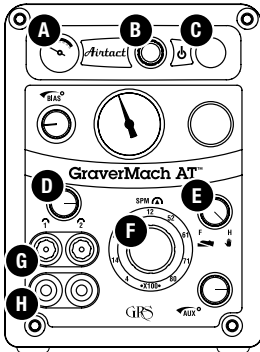

- A. Airtact air gauge
- B. Airtact air pressure control knob
- C. Power on/off button
- D. Handpiece selector knob
- E. Hand/foot control selector knob
- F. Strokes Per Minute (SPM) dial
- G. Airtact Handpiece fittings
- H. Standard Handpiece fittings

- If engraving system is powered on, press the on/off button (FIG. 8.C) to power off. This closes the air valve.
- Connect the smaller hose to the Airtact Handpiece fitting 1 (FIG. 8.G) by gently twisting the hose end connector half a turn clockwise until secure.
- Connect the larger handpiece hose to the Standard Handpiece fitting 1 (FIG. 8.H).
- Repeat with fittings 2 to add second handpiece.
- Use Handpiece Selector Knob (FIG. 8.D) to select desired handpiece for operation.
- Press the on/off button to power on the system. Check hoses for leaks and correct as needed.
- Turn the hand/foot selector knob to “hand” control (FIG. 8.E). Set Airtact air pressure as follows.

AIRTACT OPERATION *(continued)*

AIRTACT AIR PRESSURE ADJUSTMENTS

After correctly connecting Airtact Handpiece hoses as previously described, follow the instructions in section Fine Adjustments for Handpiece Operation and then continue with this section.

Once handpiece is properly adjusted, the Airtact air pressure must be set. The Airtact touch-control system includes a separate air pressure gauge and an air pressure control knob (FIG. 8.A and B), located above the bias control knob and the primary air pressure control knob.

At approximately 12 psi (0.8 bar), the Airtact touch-control system will provide full power for any handpiece. A lower setting will limit range of power; this decreases the operating power in the available range.

Reducing the Airtact pressure may be desired for certain fine applications, such as fine shading. The limited power allows for a narrow range that provides predictable results, restricting the depth of shade lines. Try 4-5 psi (0.3 bar) for better control during fine shading. See FIG. 9.

For automatic, constant power without handpiece activation, place the included closed-end twist-lock cap over the Airtact fitting for the selected handpiece. This feature allows for stippling, hammering, or similar techniques where multiple hits are required with full, constant power.

To check for proper handpiece air flow and connection, place the supplied closed-end twist-lock cap (installed on fitting as delivered from manufacturer) on the fitting to provide full power without activation. If handpiece does not have full power, check and then correct problems in connections and air pressure settings before continuing.

The engraving system is now ready for operation with both Standard Handpieces using the foot throttle and Airtact Handpieces using hand control.

FIG. 9

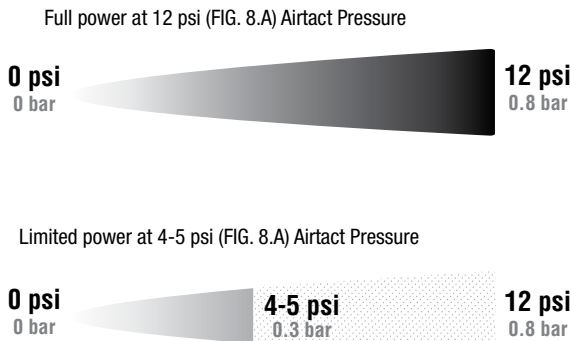
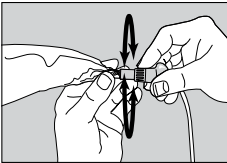
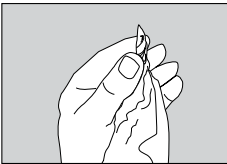
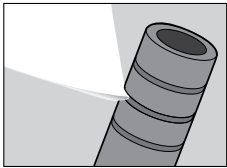
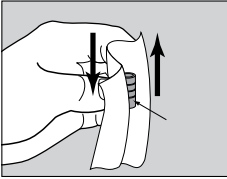
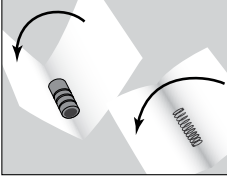

FIG. 10



MAINTENANCE

HANDPIECE

Keep the handpiece clean for proper operation. Cleaning is necessary if operation becomes sluggish, erratic, or fails. Refer to FIG. 10 and the instructions below for the proper way to clean a handpiece.

- Remove the piston and spring from the handpiece.
- Wrap each separately in a sheet of writing or printing paper.

⚠ DO NOT USE paper towel, tissue, or newsprint.

- Hold the wrapped piece. Buff and polish each piece with the paper to remove any dirt or residue.
- Remove piece from paper. For grooved pistons, fold paper to create a thick edge. Insert the paper edge in each piston groove. Use the same folded paper to clean open space in spring.
- Twist the paper to a point that will fit into the handpiece barrel. Insert and rotate the paper to buff and polish the inside until clean.

- Reassemble handpiece.

⚠ IMPORTANT NOTE: DO NOT LUBRICATE PISTON, SPRING, OR BORE.

FOOT THROTTLE

The throttle requires little maintenance with proper use. Remove any dust, debris, and metal chips from foot throttle to clean periodically. Place a drop of oil on the throttle hinges to prolong spring life and prevent rust. When sweeping or vacuuming, place foot throttle on bench or chair.

GRS ULTRA 850 ROTARY HANDPIECE

Refer to the GRS 850 operating instructions for routine maintenance of the rotary handpiece.

⚠ DO NOT EXCEED 35 psi (2.4 bar) during operation.

IMPORTANT NOTICES

GRS PROGRESSIVE FOOT THROTTLE OWNERS

The GRS Progressive Foot Throttle will operate properly with this engraving system. Attach the GRS Progressive Foot Throttle to the "THROTTLE CONNECTION" push-to-connect fitting on the back of the system.

AIR CONTAMINANTS AND WATER ACCUMULATION

If large amounts of water and contaminants are in the air supply to the system, the bowl must be drained frequently to prevent water from entering the rotary valve, hoses, handpiece, etc. Check all filters, bowls, hoses, etc., twice a week to prevent accumulation.

Additionally, the filter element must be cleaned and/or replaced frequently. If moisture is noted in the handpiece or throttle hoses, power off system immediately. Purge air from system, drain filter bowl, and proceed as follows:

- Disassemble and clean handpiece(s). Reassemble.

- Set primary air pressure to 10 psi (0.7 bar). Power on the system to purge moisture from valves, hoses, etc.

- Locate the drain plug to the internal air reservoir (FIG. 1.W). Use a 3/16" hex wrench to remove the plug; drain any moisture from reservoir. Replace drain plug.

- Before powering on engraving system, locate source of moisture and correct problem. An additional filter or water trap in the air line may be necessary.

PALM PAD FINE ADJUSTMENT

Last Update: October 16, 2012

LIT-365

Type-E Palm Pads

The latest palm pad design for Airtact hand control is Type-E, available in four sensitivity levels: 4, 6, 8, and 10. The handpiece is more responsive (less force required to activate) with a lower number palm pad installed.

Initially, palm pads can be stiff. This affects the feel and control. Stiffness may be reduced naturally with a few hours of use. To reduce stiffness quickly, bend and twist the control flap to soften. When the preferred softness is nearly reached, stop and test frequently to adjust until desired responsiveness is attained. The rubber control flap can be formed for a custom feel as well.

Forming the Rubber Control Flap

The flexible rubber control flap on the Palm Pad transforms hand force into handpiece power by progressively covering a small air vent hole in the upper rear of the Airtact handpiece knob.

Forming or bending the control flap one way (concave) increases the required hand force; bending it the other way (convex) decreases hand force.

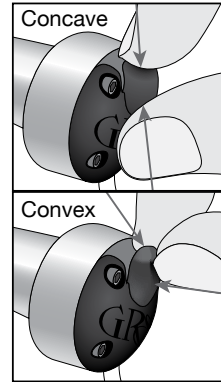

To increase required hand force:

Bend the control flap into a more concave shape. Bending the flap this direction keeps the flap from sealing off the Airtact knob hole until more hand force is applied.

To decrease required hand force:

Bend the flap into a more convex shape to decrease the hand force required. This shape seals the Airtact Knob hole with less force applied.

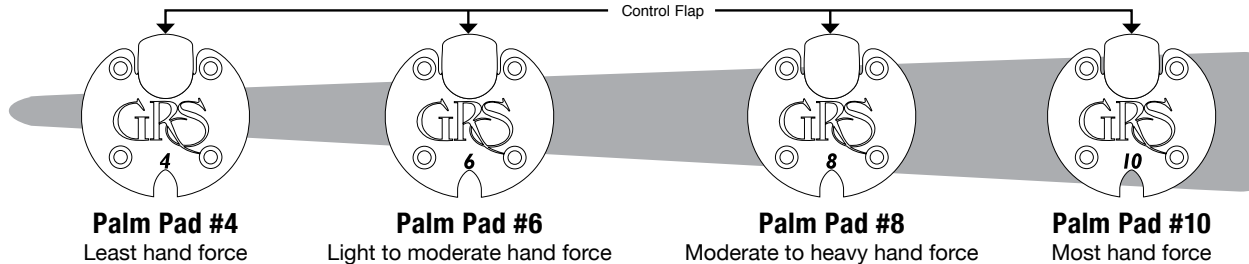

Service & Repair

Please call GRS or an authorized GRS dealer to order replacement parts and for instructions on replacement. Do not attempt to service parts that must be sent to GRS or an authorized GRS dealer; these must be repaired or replaced by GRS or an authorized GRS dealer. Servicing parts not signified as operator serviceable will void the 2-year warranty. **Any part not noted as replaceable or serviceable by the operator must be sent in to GRS or an authorized GRS dealer for repair.**

ORDER REPAIR OR REPLACEMENT PARTS

These parts are replaceable by the operator. Normal Wear and Tear, Abuse, Misuse, or Loss are not covered by warranty.

See illustrations on page 18.

RHMS, #8-32 x 0.25" Z/P	.002-568
Tubing, PU CLR 0.250" O.D., 0.170" I.D. (Foot Throttle Hose)	.004-050
Fitting, PTC 0.25" 90° M1/8" NPT	.022-230
Fitting, PTC 0.25" Inline M1/8" NPT	.022-231
Assembly, 5-Micron Filter and Bowl	.022-944
RHMS, M4 x 0.7MM [Qty: 2]	.022-978
Bracket, Filter Mount	.044-051
Tubing, PU BLK 0.250" O.D., 0.130" I.D.	.044-069
Tubing, PU BLK 0.250" O.D., 0.130" I.D.	.044-229
Allen Wrench, 1/8"	.022-053
Fitting, B-1/4" I.D. TUBE M1/8" NPT	.002-361
Power adapter	.022-872, .022-987, .022-993
Foot Throttle (Hose 004-050 not included)	.004-519

OPERATOR SERVICEABLE PARTS

Call GRS or an authorized GRS dealer for instructions and ordering information before attempting to service or replace these parts.

GraverMach® AT Box Parts	page 19
Motor Assembly (<i>not Motor Valve Assembly</i>)	page 25

GraverMach[®] AT Accessories

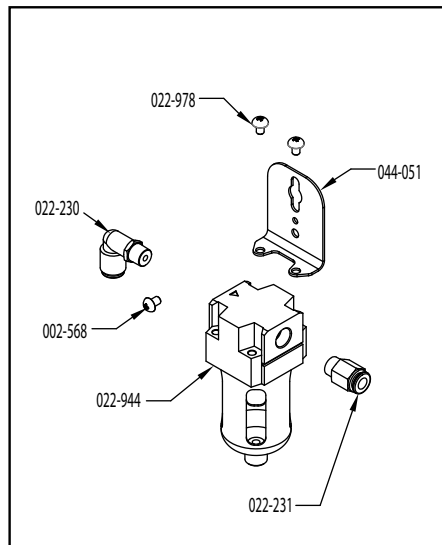

Order Replacements:

022-860	1	BOWL & COVER REPLACEMENT
022-861	1	FILTER REPLACEMENT

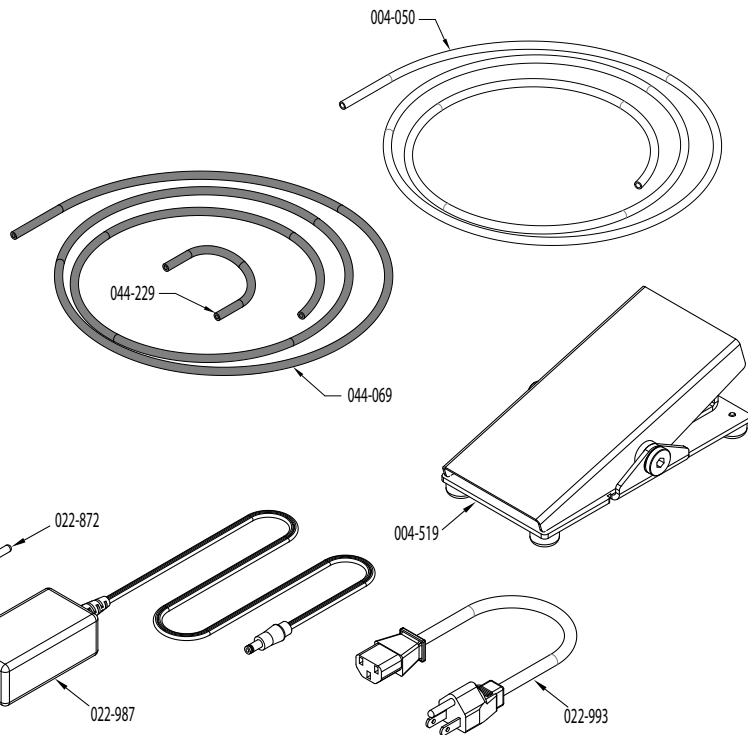

GraverMach® AT Box Parts List

Contact GRS or an authorized GRS dealer for replacement parts or repairs. Visit grs.com/dealers for dealers in your country.

PART NO.	QTY.	DESCRIPTION
002-109	8	NUT, #10-32 HEX Z/P
022-964	8	BHSCS, #10-32 x 0.38" BLK
044-180	2	PLATE, GRAVERMACH® AT SIDE FRAME
044-181	1	PLATE, GRAVERMACH® AT TOP FRAME
044-182	2	BOX CORNER, GRAVERMACH® AT

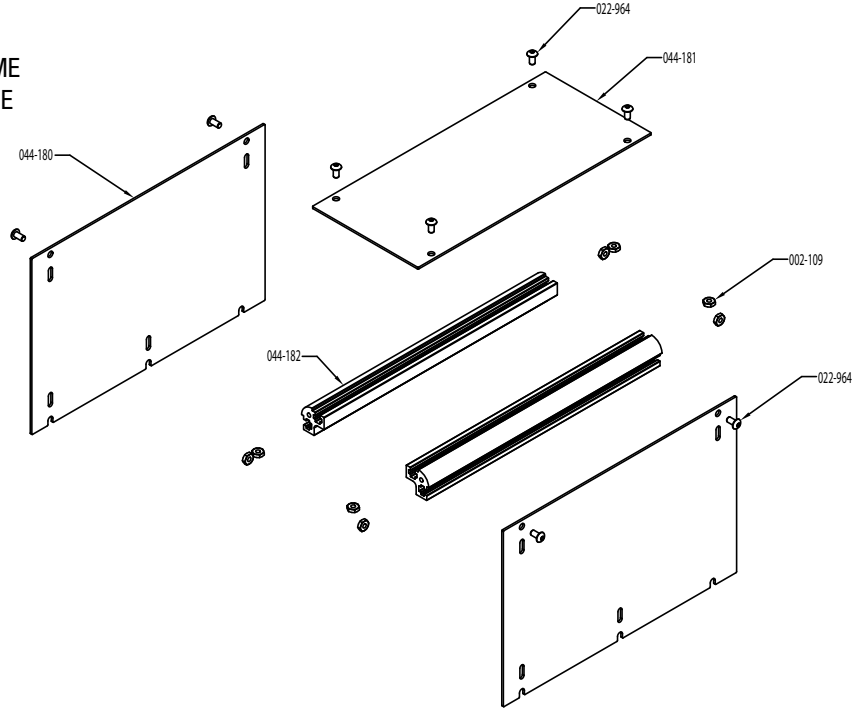
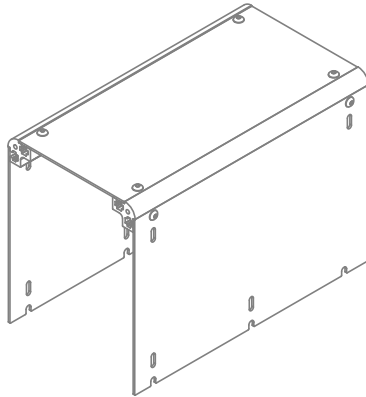

GraverMach® AT Front Face Plate & Motor Valve Parts List

PART NO.	QTY.	DESCRIPTION	PART NO.	QTY.	DESCRIPTION
002-110	4	WASHER, #8 FLAT Z/P	024-039	1	DECAL, GRAVERMACH® AT AIRACT
002-309	8	HHSMS, #6 x .38" Z/P	024-040	1	DECAL, GRAVERMACH® AT ON/OFF
002-333	1	O-RING, 0.313" O.D., 0.188" I.D.	024-120	1	KNOB, B-G 0.75" O.D., 0.19" I.D. x 0.70"
002-443	2	BHCS, #6-32 x 0.25" BLK	044-044	1	NEEDLE, VALVE
002-615	1	GAUGE, 1.63" O.D., 0-60 psi AIR	044-065	1	TUBING, PU CLR 0.250" O.D., 0.170" I.D.
002-766	6	CLAMP, WIRE, 0.25" O.D. TUBE	044-065	1	TUBING, PU CLR 0.250" O.D., 0.170" I.D.
002-971	1	PLUG, 0.190" O.D. x 0.125" SINTERED	044-067	1	TUBING, PU CLR 0.250" O.D., 0.170" I.D.
002-977	1	O-RING, 0.188" O.D., 0.063" I.D.	044-112	1	TUBING, PU CLR 0.250" O.D., 0.170" I.D.
004-966	1	VALVE, 4-WAY SWITCHING	044-177	1	PLATE, GRAVERMACH® AT FRONT FRAME
022-080	1	FITTING, B-0.17" I.D. TUBE M#10-32	044-185	1	VALVE BODY, AUXILIARY AIR
022-875	1	VALVE, PTC 0.25" NEEDLE	044-186	1	BRACKET, 1.10" AIR GAUGE
022-966	1	FITTING, PTC 0.25" 90° F 1/8" NPT	044-187	1	BRACKET, 1.63" AIR GAUGE
022-970	1	SWITCH, ILLUMINATED POWER	044-224	1	TUBING, PU CLR 0.250" O.D., 0.170" I.D.
022-980	1	REGULATOR, PRECISION AIR	044-225	1	TUBING, PU CLR 0.250" O.D., 0.170" I.D.
022-982	2	KNOB, GRAY 0.75" O.D., 0.25" I.D. x 0.69"	044-225	1	TUBING, PU CLR 0.250" O.D., 0.170" I.D.
023-019	1	GAUGE, 1.10" O.D. 0-30 psi AIR	044-226	1	TUBING, PU CLR 0.250" O.D., 0.170" I.D.
023-020	1	FITTING, PTC 0.25" 90° M #10-32	044-226	1	TUBING, PU CLR 0.250" O.D., 0.170" I.D.
023-021	4	FITTING, PTC 0.25" 90° M 1/8" NPT	044-230	1	TUBING, PU CLR 0.156" O.D., 0.094" I.D.
023-030	1	FITTING, B-Y 0.19" I.D. TUBE	044-500	1	WIRE, R-L-B-22 AWG POT F-SPADE
023-054	1	KNOB, B-G 1.25" O.D., 0.25" I.D. x 0.61"	044-501	1	WIRE, R-22 AWG F-SPADE T-RING
024-038	1	DECAL, GRAVERMACH® AT FRONT	044-501	1	WIRE, R-22 AWG F-SPADE T-RING
			044-502	1	WIRE, B-22 AWG F-SPADE T-RING

GraverMach® AT Motor Valve Assembly

PART NO.	QTY.	DESCRIPTION
004-951	1	VALVE BODY, ROTARY
022-230	2	FITTING, PTC 0.25" 90° M1/8" NPT
022-948	1	O-RING, 1.078" O.D., 0.938" I.D.
022-977	1	FITTING, PTC 0.25" T M-1/8" NPT
022-990	1	WASHER, 0.63" O.D., 0.41" I.D. x 0.03" NY
044-006	1	VALVE SHROUD, ROTARY

Contact GRS or an authorized GRS dealer for replacement parts or repairs. Visit grs.com/dealers for dealers in your country.

22 GraverMach® AT Back Parts List

PART NO.	QTY.	DESCRIPTION	PART NO.	QTY.	DESCRIPTION
002-062	2	RHMS, #8-32 x 0.50" Z/P	024-041	1	DECAL, AUXILIARY OUTPUT
002-092	2	TERMINAL, 22-16 AWG #10 RING	024-042	1	FITTING, PTC 0.25" M#10-32
002-104	2	NUT, #8-32 HEXKEP Z/P	024-118	2	NUT, #4-40 HEX Z/P
002-186	2	RIVET, 0.125" DIA. x 0.125" POP	024-119	2	RHMS, #4-40 x 0.63" Z/P
004-809	1	WIRE, B-22 AWG T-RING T-RING	044-059	1	DECAL, AIR INPUT/THROTTLE
004-815	1	WIRE, R-22 AWG F-SPADE T-RING	044-111	1	TUBING, PU BLK 0.250" O.D., 0.130" I.D.
004-816	1	WIRE, B-22 AWG F-SPADE T-RING	044-111	1	TUBING, PU BLK 0.250" O.D., 0.130" I.D.
004-817	1	WIRE, R-22 AWG F-SPADE F-SPADE	044-179	1	PLATE, GRAVERMACH® AT REAR FRAME
004-818	1	WIRE, B-22 AWG F-SPADE F-SPADE	044-189	1	SERIAL PLATE, GRAVERMACH® AT
022-245	1	GROMMET, 0.50" O.D., 0.188" I.D. RUBBER	044-222	1	BRACKET, SOLENOID
022-962-R-PART	1	CONTROLLER, 24VDC PWM MOTOR	044-228	1	TUBING, PU BLK 0.250" O.D., 0.130" I.D.
022-965	3	FITTING, PTC 0.25" BULKHEAD	044-228	1	TUBING, PU BLK 0.250" O.D., 0.130" I.D.
023-032	1	FITTING, PTC 0.25" T	044-503	1	WIRE, B-R-22 AWG P-JCK F-SPD T-R
024-036	1	VALVE, 24VDC SOLENOID	LIT-294	1	DECAL, DRY AIR NOTICE

Contact GRS or an authorized GRS dealer for replacement parts or repairs. Visit grs.com/dealers for dealers in your country.

24 GraverMach® AT Base Parts List

PART NO.	QTY.	DESCRIPTION
002-309	6	HHSMS, #6 x 0.38" Z/P
002-536	3	NUT, 1/4"-20 FLNG LOCK Z/P
011-209	4	FOOT, #8-32 x 0.50" RUBBER
022-222	3	SOCKET HEAD CAP SCREW
022-230	1	FITTING, PTC 0.25" 90° M1/8" NPT
022-231	3	FITTING, PTC 0.25" INLINE M1/8" NPT
022-381	1	PLUG, 1/8"-27 NPT x 0.25" PIPE
022-964	6	BHSCS, #10-32 x 0.38" BLK
024-168	3	SPECIAL WASHER
024-169	1	O-RING
044-178	1	PLATE, GRAVERMACH® AT BASE
044-223	1	TUBING, PU CLR .250" O.D., 0.170" I.D.
044-256	1	MOLDED AIR TANK (FOUR HOLE VERSION)

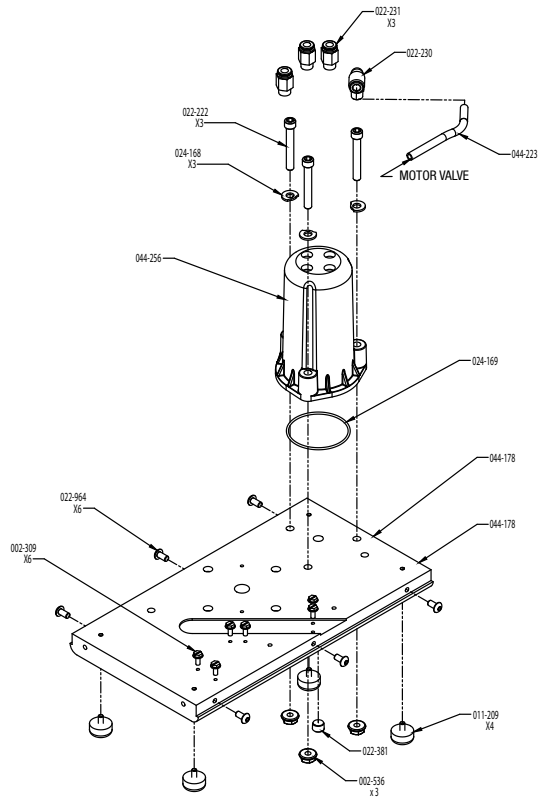
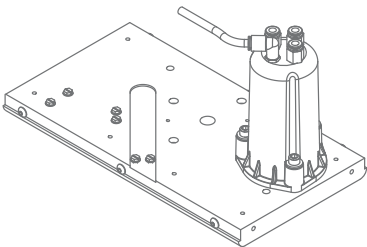

GraverMach® AT Spool Assembly

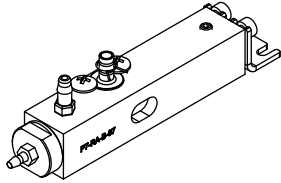

Spool Assembly

The Spool Assembly is NOT OPERATOR SERVICEABLE. This part is factory set to this particular system. Repair or replacement requires return of engraving system to GRS or an authorized GRS dealer.

GraverMach® AT Motor Assembly

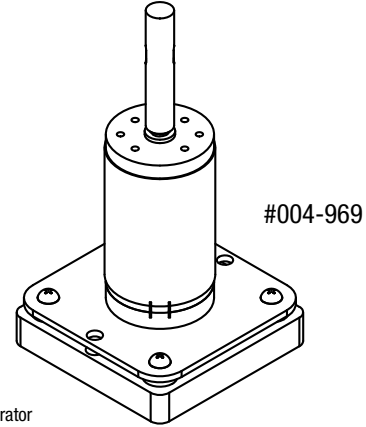

Motor Assembly

The Motor Assembly is operator replaceable. Contact GRS or an authorized GRS dealer for details.

Contact GRS or an authorized GRS dealer for replacement parts or repairs. Visit grs.com/dealers for dealers in your country.

GraverMach® AT Hose Diagram

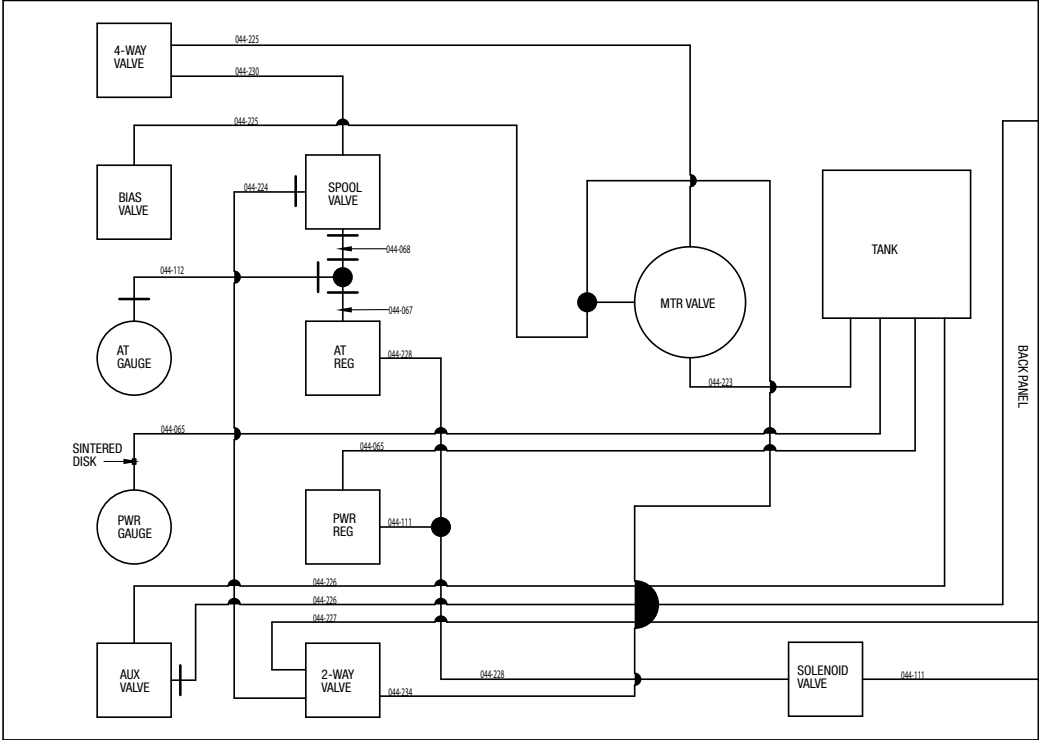

WARRANTY

Each GraverMach® AT, including provided foot throttle, carries a full 2-year warranty covering parts and labor. Contact GRS or an authorized GRS dealer before returning any equipment.

 These products are designed for reliable operation using most sources of compressed air. However, some air supplies contain excessive water, oil, dirt, rust, or other contaminants. The built-in filter of the engraving system is a final filter to protect against normal dirt and water. If the compressed air has excessive contaminants, install the necessary filter(s) and water trap(s) ahead of the engraving system.

 Oil contamination can be gradual and subtle. If an oil residue (usually yellow or brown, sticky or liquid) becomes present in the filter bowl of the engraving system, or in the handpiece / throttle hose, the compressed air most likely contains oil or contaminants. Older oil lubricated and “silent” compressors that use internal oil are more likely to cause oil contamination. If this occurs, install a Coalescing Oil Filter (GRS #004-579 or equivalent).

NOTE: Damage caused by contaminated compressed air is not covered by the warranty.



Glendo Corporation
900 Overlander Road
Emporia, KS 66801 USA

Phone: +1-620-343-1084
Fax: +1-620-343-9640
E-mail: glendo@glendo.com

www.grstools.com

GraverMach® AT, GraverMach®, GraverMax® G8, GraverMax® SC, GraverMax®, GraverMate®, GraverSmith®, BenchMate™, and Power Hone™ are trademarks of Glendo Corporation. Covered by USA and foreign patents. Printed in USA. Products made in USA.
© 2009-2014 Glendo Corporation. All rights reserved.
