

Ring Stretcher/Reducer/Bender

by Pepetools

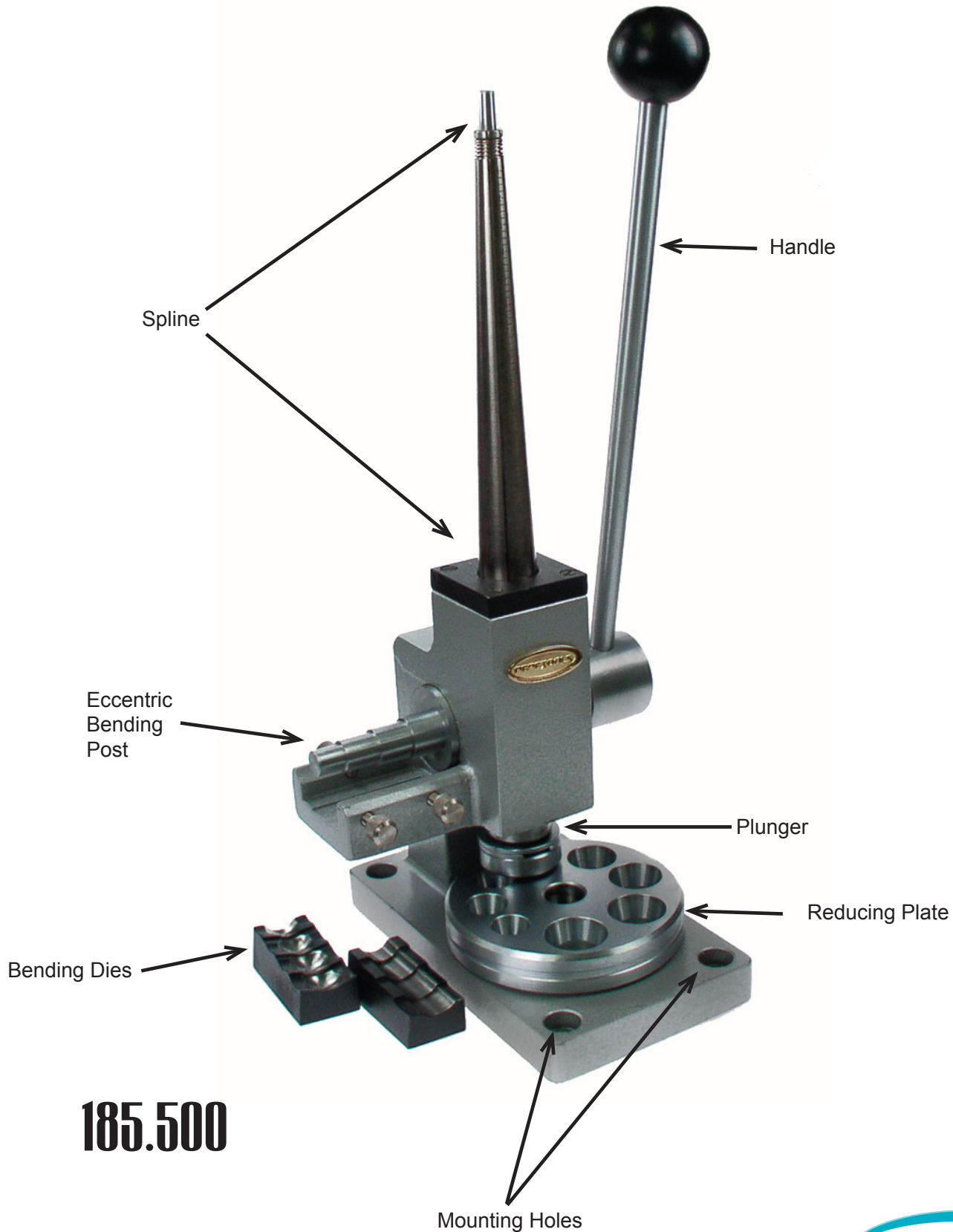

185.500



OPERATING INSTRUCTIONS

Mount the Ring Stretcher to a sturdy workbench or table.

To enlarge a wedding band:

First check the size on a ring stick. Slip the ring on the spline of the stretcher. On each movement of the handle down, slightly turn the ring on the spline before the up movement of the handle. After two or three movements of the handle upward, turn the ring over. This is to compensate for the tapered spline. Note that the numbers on the spline are for reference only. Stretching of the ring is done in very small increments and it is important that the ring size is checked frequently. How much a wedding band can be enlarged or reduced in size depends on the construction of the band and metal softness. As far as softness is concerned, the ring can be made softer by the annealing process. Most rings of average size, in reference to thickness, can be enlarged approximately one size.

Although it is a rare occurrence, after stretching a ring, it may be necessary to buff or polish the inside of the ring. This depends on how soft the metal is and or how much the ring was changed in size.

To reduce the size of a wedding band:

First choose a reduction depression on the two-sided reduction plate. Select a depression on which the ring will extend approximately 1 to 2 mm above the plate. Wrap the outer surface of the ring with masking tape and place the ring in the chosen depression. Move the handle down and the plunger above the depression will come down and push the ring down into the depression. Turn the ring over and repeat the procedure. This action will reduce the circumference of the ring. Be sure to check the size frequently.

Important Ring Enlargement Information.

Cast rings or rings with soldered shanks are likely to crack if stretched.

The safest method for enlarging cast rings or rings with stones is to use the roller-type ring enlarger PEPETOOLS® item # 142.00 or 142.500, or to cut the shank and add a section of shank material.

Operating the RING BENDER

1. Remove the reducing plate when operating the ring bender.
2. The large flat plunger screw which is used in the reduction process must either be extended by turning the plunger to the left (CCW) or it may be completely removed. This is necessary to allow ample up and down movement of operating handle and of the Eccentric bending post.

The large slotted washers are to be used when reducing rings to provide support to the reducing plunger when the plunger is in an extended position. Simply slide the slotted washer on to the threaded portion of the plunger and slightly hand tighten the plunger screw.