

ZERO WASTE

STAINLESS IMPACT RECOVERY BOLLARDS



The ultimate carpark bollard



ZERO DAMAGE
To Impact Recovery Rings

ZERO DAMAGE
To concrete footing or base plate

ZERO DAMAGE
To bollard

City of Perth had a problem maintaining bollards in the busy city centre. They came to us to develop a solution that would provide protection for café strips and pedestrians, reduce damage to vehicles and reduce the escalating cost of maintaining their bollards. We developed the Impact Recovery System that provides a low cost and sustainable solution to all of these problems. Combined with ZerOPoly covers

4 Levels of extreme protection impact after impact

Protecting costly foundations - You can secure Bollards using our ZerO Waste Foundations that, unlike metal sockets, are unbreakable, so continue working impact after impact for the life of a development or surface mount your bollards using our Reusable base plate

1. Unlike spring loaded bollards that over-flex, a heavy-duty resistance core prevents deflection of the bollard beyond 20 degrees when impacted by a passenger vehicle at low speed such as a carpark
2. Unlike springs that quickly rust and wear out, creating dangerous litigation risks, our re-usable shock absorbing Impact Recovery Rings create a permanent shock absorbing cushion that absorb the impact force of a vehicle and self-recover, with no reduction in capacity following hundreds of impacts, greatly improving safety and resilience
3. Unlike cheap tube (often imported) bollards that dent upon impact from a vehicle, our heavy-duty stainless-steel pipe bollards provide an impact resistant surface and are polished to a nice satin finish, so they not only look good but stay that way for years to come

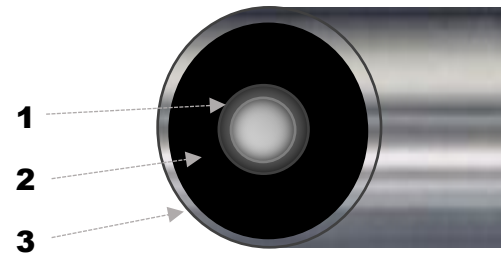

We get knocked down, but we get up again. You're never going to keep us down!

Unlike spring-loaded bollards, ZERO Impact Recovery Bollards cannot be deflected by hand, but when impacted by a vehicle they deflect to a max of 20 degrees and self-recover, remaining perfectly aligned safe and secure year after year.

When severely impacted (truck or utility vehicle) replacements take less than 5 minutes and the bollard, expensive concrete footings and Impact Recovery Rings are reusable impact after impact, saving thousands over the life of a development.

20 degrees Max

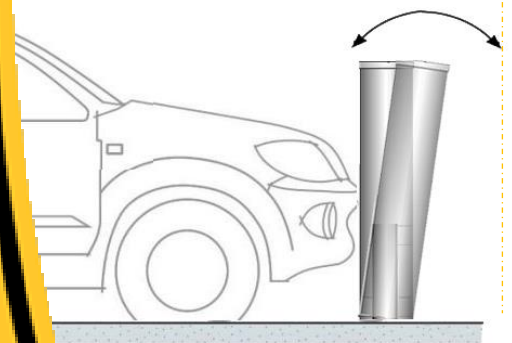

Upon Low Impact

Bollards remain rigid and appear to be solid inground bollards but when impacted by a vehicle they absorb the impact force deflecting a maximum of 20 degrees and self-recovering, with no diminished capacity following hundreds of impacts.

Severe Impact

When severely impacted instead of the entire footing being dislodged, the inner resistance core bends allowing the bollard to fold but not be dislodged- preventing any further forward movement of the vehicle and enabling fast reinstatement

Fast efficient replacements

Replacements are simple Following severe impact bollard is easily removed (resistance core replaced) and reinstated in around 5 mins Bollards and Impact Recovery Rings are re-usable impact after impact, improving safety & efficiency



Stop replacing bollards & foundations!

Did you realise that both inground and surface mount bollards are designed to fail upon impact so both the bollard and footing need repeatedly replacing. If impacted only 2 x a year you need to pay for the bollard, plus replacement costs and tipping fees, which equates to more than \$1 million per bollard + over the life of the development

Make bollard reusable

All over the internet you see cheap imported stainless-steel bollards- and the pictures look great but you get what you pay for!

These extremely cheap bollards are made from thin-walled tube (shiny finish as shown right) which dent easily and imported tube scratches, dents and rusts in no time - making them unsuitable for outdoors or locations where they may experience impact from trolleys or vehicles.



Make footing reusable

When impacted- something's gotta give! So, unless you incorporate a shock absorbing mechanism either the bollard (if tube) will bend, or footings will be damaged! There's never a good outcome!

Until now spring-loaded bollards were the only solution but are almost useless as they offer no protection and quickly wear out. Removable bollards on metal sockets are almost as useless and rarely last beyond 12 months

These bollards shown left were installed in City of Perth around the same time as the ZERO Bollards below, but whilst these already look totally worn out ZERO Impact Recovery Bollards still look perfect and are still in good working condition. It's a small investment for a lifetime of saving money and reducing waste to ZERO.

Stainless steel bollards

Our Heavy walled Stainless-steel Impact Recovery Bollards absorb impact from vehicles and self-recover without denting (as ZERO Rings absorb the impact force, and the bollard casing is strong enough to take the blow) Highly resistant to rust and corrosion- **Aussie made to last!**



Range of options

- Inground (removable) or surface Mount
- Standard units are Satin finish (brushed- which is the most durable finish for outdoors)
- Standard units have a shiny finish but not high gloss (high gloss is usually indoor bollards made from stainless steel tube) although we can bring pipe to high shine it is not recommended for outdoors – lots of maintenance
- Reflective striping (red or white) optional
- Flat seamless cap



SURFACE MOUNT

You can safely surface mount your bollards using our base plate that is reusable impact after impact.



INGROUND 350 MM

Foundations that last a lifetime. Carpark bollards can be installed on 350 mm footings. *



INGROUND 650 MM

* When bollards may be subject to severe impact or will be installed in free standing foundations

Inground or Surface Mounting options

ZERO WASTE Unbreakable ground sockets (350 or 650mm depth) can be installed when pouring concrete footings by simply positioning upright, creating a perfect finish (and can be capped if bollard is removed)

Bollards are simply dropped into position (no pins or padlocks) “automatically” locking in using friction, which ensures they remain safe and secure perfectly aligned impact after impact, year after year.

Surface Mount base plate is heavy duty round base plate (to evenly distribute the impact force) secured using quality recessed and galvanised flush mounted concrete anchors and are reusable impact after impact.



08 92485545
hello@zerocivil.com
zerocivil.com