

# EPOCH BATTERIES

## 12460ES

### User Manual

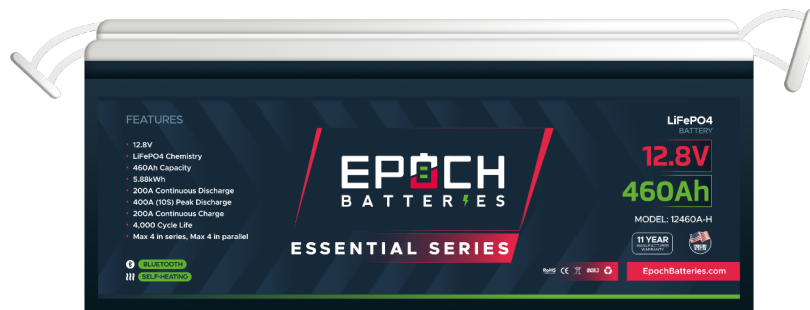

Revised: 04/04/24

## **Legal Provisions**

**Purpose and Importance of the Guide:** This guide is meticulously crafted to offer detailed and comprehensive instructions for the safe installation, operation, and maintenance of 12460ES lithium battery packs. It's imperative that all users, prior to commencing any installation, operational, or maintenance activities, thoroughly review this manual. The information contained herein is vital for ensuring the correct and safe handling of the battery packs.

**Qualification for Handling:** The procedures and tasks described in this manual are intended to be performed by qualified individuals who possess the necessary technical skills and understanding. These precautions are set to mitigate any potential damage to the product and, more importantly, to minimize personal safety risks. Unqualified handling can lead to improper installation or usage, which may not only compromise the performance of the battery but also pose significant safety hazards.

## **Warranty and Compliance**

**Adherence to Safety Guidelines:** Failing to adhere to the safety guidelines outlined in this manual can result in the nullification of the product's warranty and disqualification from any warranty claims. This stipulation underscores the importance of following the prescribed safety and operational protocols.

**Manufacturer's Liability:** Epoch Batteries explicitly disclaims any liability for damages or injuries that may arise from non-compliance with the manual's guidelines. This includes product damage, property damage, personal injury, or loss of life. Users are reminded that adhering to the guidelines is not just a matter of maintaining the warranty but also a crucial aspect of safety.

## **Information Accuracy and Updates**

**Content Validity:** The content provided in this manual is deemed accurate and reliable as of its date of publication. However, Epoch Batteries holds the right to make modifications to the product specifications. These modifications may include optimizations, enhancements, or other types of alterations, and can be made without any prior notice.

**Version Consultation:** To ensure that users have access to the most current and accurate information, it is recommended to consult the latest version of this manual. Regularly checking for updates ensures that users are aware of any changes or improvements made to the product or its guidelines.

## **Illustrations and Representations**

**Diagrams and Schematics:** The diagrams and schematics included in this manual are intended to aid in the understanding of the system configuration and the installation process. They are designed to be illustrative and may not precisely represent the actual components found at the installation site.

**Understanding Variations:** Users should be aware that the actual setup might differ slightly from the illustrations, and adjustments might be needed to accommodate specific installation scenarios.

## **Intellectual Property and Usage Rights**

**Copyright Protection:** The manual is the intellectual property of Epoch Batteries, and as such, any unauthorized extraction, reproduction, or translation of its contents is strictly prohibited. This restriction is in place to protect the integrity and proprietary nature of the document.

**Consent Requirement:** Permission for any form of reproduction or translation must be obtained in writing from Epoch Batteries. This ensures that the dissemination of the material is controlled and that the information remains accurate and reliable.

# Table of Contents

<b>Introduction</b> .....	8
Welcome.....	8
Purpose and Scope.....	8
Commitment to Quality and Support.....	8
Part of Your Energy Journey.....	8
Appreciation.....	8
About This Manual.....	9
Comprehensive Coverage.....	9
User-Friendly Structure.....	9
Safety Emphasis.....	9
Support and Feedback.....	9
Conclusion.....	9
<b>Product Overview</b> .....	10
Versatile Applications.....	10
Off-Grid Power Systems.....	10
Solar Energy Storage.....	10
Marine and RV Power.....	10
Backup Power Solutions.....	10
Key Features.....	10
Advanced LiFePO <sub>4</sub> Chemistry.....	10
High Capacity.....	10
Compact Design.....	10
Durable Construction.....	11
Wide Temperature Range.....	11
Integrated Heating System.....	11
Maintenance-Free.....	11
Emphasis on Safety.....	11
Advanced Communication Capabilities.....	11
<b>Specifications</b> .....	12
<b>Safety Guidelines</b> .....	13
Comprehensive Understanding.....	13
Intended Usage.....	13
Secure Storage.....	13
Professional Handling.....	13
Temperature Constraints.....	13
Charger Compatibility.....	13
Charging Oversight.....	13
Fire Extinguishing Methods.....	14
Responsible Disposal.....	14
Additional Safety Measures.....	14

<b>Installation Guide</b> .....	15
Location.....	15
Ventilation.....	15
Dry Environment.....	15
Avoid Direct Sunlight.....	15
Stable Temperature Conditions.....	15
Accessibility.....	15
Safety Compliance.....	15
Mounting.....	16
Orientation.....	16
Epoch Li-Ion App.....	16
<b>Connection Guide</b> .....	17
Ensuring Correct Polarity.....	17
Series and Parallel Connections.....	17
Series Connections.....	17
Voltage Increase.....	17
Capacity Maintenance.....	17
Use Cases.....	17
Parallel Connections.....	18
Voltage Consistency.....	18
Capacity Increase.....	18
Use Cases.....	18
Busbar System.....	18
Advantages.....	18
Considerations.....	18
Daisy-Chaining.....	19
Advantages.....	19
Considerations.....	19
Best Practices.....	19
Series-Parallel Connections.....	20
Combining Methods.....	20
Configuration Example.....	20
Important Considerations.....	20
Compatibility.....	20
Safety Precautions.....	20
Terminal and Cable Management.....	20
Terminal Inspection.....	20
Cable Routing.....	20
Overcurrent Protection.....	21
Fuses and Circuit Breakers.....	21
Choosing the Right Protection.....	21
Voltage Rating.....	21
Type Selection.....	21
Testing and Professional Assistance.....	21
System Testing.....	21
Seeking Help.....	21

<b>Charging Guide</b> .....	22
Initiate Charge.....	22
Power Activation.....	22
Visual Indicator.....	22
Compatible Chargers.....	22
Charging Parameters.....	22
Specific Voltages.....	22
Voltage and Current Limits.....	22
Charge Control.....	22
Initial Full Charge.....	23
Charging Process.....	23
Correct Polarity.....	23
Active Monitoring.....	23
Charging Environment.....	23
Temperature Management.....	23
Optimal Range.....	23
Extreme Temperature Avoidance.....	23
Safety Precautions.....	23
Monitoring.....	23
<b>Usage Guide</b> .....	24
Activating Discharge.....	24
Power On.....	24
Visual Confirmation.....	24
Optimal Operating Conditions.....	24
Temperature Range.....	24
Avoid Extremes.....	24
Managing Discharge Depth.....	24
Shallow Discharges.....	24
Load Management.....	24
Current Limits.....	24
Storage Practices.....	25
Ideal Conditions.....	25
Charge State for Storage.....	25
Standby and Backup Use.....	25
Readiness Testing.....	25
Regular Maintenance.....	25
Inspections and Testing.....	25
Disconnection When Idle.....	25
Preventing Self-Discharge.....	25
Careful Handling.....	25
Avoid Damage.....	25
Adhering to Safety Precautions.....	26
Safe Operation.....	26
Professional Consultation.....	26
Seek Expert Advice.....	26

<b>Maintenance Guide</b> .....	27
Regular Visual Inspections.....	27
Surface and Structure Check.....	27
Immediate Action.....	27
Terminal and Connector Maintenance.....	27
Cleaning Process.....	27
Securing Connections.....	27
Tightness Check.....	27
Re-tightening Procedure.....	27
Voltage Monitoring.....	27
Regular Testing.....	27
Voltage Comparison.....	27
Capacity Evaluation.....	27
Temperature Checks.....	28
Operational Heat Monitoring.....	28
Temperature Regulation.....	28
Implement Preventive Maintenance.....	28
Scheduled Checks.....	28
Maintenance Records.....	28
Optimal Storage Environment.....	28
Adherence to Safety Practices.....	28
Safety Gear.....	28
Avoid Direct Contact.....	28
Expert Consultation.....	28
<b>Troubleshooting Guide</b> .....	29
Battery Not Charging.....	29
Connection Check.....	29
Charger Compatibility and Function.....	29
Power Source Inspection.....	29
Low Voltage or Capacity.....	29
Load Disconnect.....	29
Visual Battery Inspection.....	29
Capacity Assessment.....	29
Overheating Issues.....	29
Temperature Range Compliance.....	29
Ventilation.....	29
Load Management.....	29
Short Circuit Concerns.....	30
Load Disconnection.....	30
Inspection of Terminals and Wiring.....	30
Continuity Testing.....	30
Abnormal Battery Behavior.....	30
Behavioral Observation.....	30
Behavior Documentation.....	30
Seek Technical Support.....	30
Failure to Hold Charge.....	30

Charging Parameter Verification.....	30
Capacity Testing.....	30
Consider Battery Age.....	30
Excessive Self-Discharge.....	31
Load Disconnection.....	31
Terminal Maintenance.....	31
Current Draw Measurement.....	31
Erratic Behavior.....	31
Environmental Factors.....	31
Connection Security.....	31
Component Testing.....	31
Seeking Professional Assistance.....	31
<b>Warranty Information.....</b>	<b>32</b>
Warranty Terms.....	32
Duration of Coverage.....	32
Coverage Scope.....	32
Exclusions from Warranty.....	32
User-Related Damages.....	32
Unauthorized Modifications.....	32
External Causes.....	32
Non-Approved Accessories.....	32
Warranty Claim Procedure.....	33
Initiating a Claim.....	33
Assistance and Guidance.....	33
Inspection and Resolution.....	33
Limitation of Liability.....	33
Extent of Responsibility.....	33
Exclusion of Indirect Damages.....	33
Consumer Rights.....	33
Legal Rights.....	33
Statutory Rights.....	33
Warranty Support Contact.....	33
Support Team.....	33
Maintaining Your Warranty.....	34
Proof of Purchase.....	34
Queries and Assistance.....	34

# Introduction

## Welcome

Welcome to the comprehensive user manual for the 12460ES, a state-of-the-art battery system. We are thrilled to provide you with this detailed guide, meticulously crafted to help you achieve the best possible performance, safety, and longevity from your battery investment. This manual represents our dedication to delivering excellence in both our products and the support we offer.

## Purpose and Scope

This guide is designed to be your ultimate resource for understanding and utilizing your 12460ES battery. It is filled with in-depth information on the battery's features, technical specifications, and operational best practices. The manual caters to a broad spectrum of users, from seasoned professionals in the field to individuals who are engaging with advanced battery systems for the first time. Our goal is to equip you with the necessary knowledge and confidence to fully leverage the capabilities of your 12460ES battery, ensuring that you can make the most of its advanced features and enjoy its robust performance.

## Commitment to Quality and Support

Our commitment to you goes beyond providing a high-quality battery. We are dedicated to offering exceptional customer support to accompany our premium product. Should you encounter any questions or require assistance with your 12460ES, our team of experienced professionals is readily available. We are here to provide comprehensive support, ensuring that any inquiries or issues are resolved promptly and to your complete satisfaction.

## Part of Your Energy Journey

We are proud to be an integral part of your energy solutions. The 12460ES is designed to meet and exceed your expectations in both performance and reliability. By choosing our product, you are investing in a solution that promises efficiency and endurance. We sincerely thank you for trusting Epoch Batteries with your energy needs and look forward to being a key component in your energy journey.

## Appreciation

Thank you for choosing Epoch Batteries. Your trust in our brand and products is greatly valued, and we are committed to upholding the high standards that you expect from us.



# About This Manual

## Comprehensive Coverage

This manual is a complete repository of knowledge for the 12460ES. We have meticulously compiled all the information necessary for you to understand, install, and optimally maintain your battery. The content of this manual is extensive and covers every aspect of the 12460ES, ensuring you have a thorough understanding of your product.

## User-Friendly Structure

Recognizing the diverse range of our users, we have structured this manual to be as accessible and straightforward as possible. It provides clear, step-by-step instructions accompanied by important safety warnings. The information is presented in an easy-to-follow format, ensuring that even complex procedures are understandable to all users.

## Safety Emphasis

Safety is a paramount concern in the operation and maintenance of battery systems. This manual contains crucial safety warnings and guidelines to ensure your experience with the 12460ES is not only effective but also safe. Adhering to these guidelines will help prevent accidents and ensure the long-term reliability of your battery.

## Support and Feedback

We encourage you to utilize this manual as a comprehensive guide for all your needs regarding the 12460ES. If you have any feedback or require further clarification on any topics covered in this manual, please do not hesitate to reach out to [Epoch Batteries \(Support\)](#). Your feedback is invaluable in helping us improve our products and the resources we provide.

## Conclusion

In conclusion, this manual is an essential tool in your journey with the 12460ES. It reflects our commitment to ensuring you have a positive and productive experience with our product.

Thanks again for choosing Epoch Batteries.

[Epoch Batteries \(Support\)](#)



# Product Overview

The 12460ES strikes an optimal balance between longevity, safety, and efficiency, making it a versatile choice suitable for a myriad of applications. Boasting a substantial 460Ah capacity, this 12-volt battery provides consistent and dependable power. Its utilization of advanced LiFePO<sub>4</sub> technology not only enhances the battery's cycle life but also assures stable performance across a range of temperature conditions.

## Versatile Applications

### Off-Grid Power Systems

Ideal for powering remote cabins, off-grid homes, and other outdoor installations, the 12460ES is a reliable cornerstone for energy storage in off-grid settings.

### Solar Energy Storage

This battery excels in storing excess solar energy, enabling usage during low-sunlight periods or at night. It is instrumental in fostering energy independence and reducing grid reliance.

### Marine and RV Power

It is perfectly suited to provide onboard power for marine vessels and RVs, enhancing travel experiences by ensuring constant power without compromising comfort or convenience.

### Backup Power Solutions

The 12460ES serves as a dependable backup power source for critical equipment and infrastructure in residential, commercial, and industrial settings, ensuring continuity and reliability.

## Key Features

### Advanced LiFePO<sub>4</sub> Chemistry

The battery's Lithium Iron Phosphate chemistry is known for its exceptional stability, safety, and longevity, ensuring reliable performance in various environments.

### High Capacity

With 460Ah capacity, it offers substantial energy storage, suitable for extensive applications ranging from off-grid systems to recreational vehicles.

### Compact Design

The battery combines high capacity with a compact, lightweight design, making it easy to install and integrate into diverse systems while optimizing space.

### **Durable Construction**

Designed for challenging environments, it features rugged housing and durable components, assuring long-term reliability and durability.

### **Wide Temperature Range**

Engineered to perform reliably across a broad temperature spectrum, it operates effectively from -20°C to 60°C (-4°F to 140°F).

### **Integrated Heating System**

The built-in heating system enables charging in cold conditions, safeguarding the cells and ensuring battery efficiency in freezing temperatures.

### **Maintenance-Free**

This battery requires minimal maintenance, providing hassle-free operation and peace of mind for the user.

### **Emphasis on Safety**

With built-in mechanisms for overcharge, over-discharge, short circuit, and thermal protection, it prioritizes safety, minimizing risks and enhancing user confidence.

### **Advanced Communication Capabilities**

Featuring Bluetooth for wireless connectivity, it allows real-time monitoring of performance data through the Epoch Batteries Li-Ion app.

# Specifications

Nominal Voltage	12.8V
Nominal Energy @ 0.2C	5.88kWh
Nominal Capacity @ 0.2C	460Ah
Internal Resistance @ 1kHz AC	≤30mΩ
Charge Voltage Range	14.2V
Float Voltage Range	13.6~13.8V
Max Charge Current	200A (400A @ 10s)
Recommended Charge Current	50A
Max Discharge Current	200A (400A @ 10s)
Recommended Discharge Current	100A
Short Circuit Protection	800A @ 500μs
Low Voltage Disconnect	10V
Reconnect Voltage	12V
Communications	Bluetooth   CAN bus   RS485
Max Series Connections	4
Max Parallel Connections	4
Terminal and Torque	M10   20 to 35Nm
IP Rating	IP21
Length	522±2 mm (20.55")
Width	218±2 mm (8.60")
Height	240±2 mm (9.45")
Weight	38kg (84lb)
Operational Temperature Range	-20°C to 60°C (-4°F to 140°F)
Operational Altitude	<3000m
Self-Discharge Rate	≤3%/month
Recommended Storage Environment	15°C to 35°C (59°F to 95°F)
Cycle Life	>4000 cycles @80%DOD

# Safety Guidelines

To ensure the highest levels of safety and to prevent potential accidents, injuries, or property damage, it is imperative to adhere to the following detailed safety instructions:

## Comprehensive Understanding

Prior to using the battery, it is essential to thoroughly read and comprehend the instructions in the manual. This involves familiarizing yourself with the battery's functions, technical specifications, and critical safety guidelines.

## Intended Usage

The battery should be utilized strictly as described in the manual. Deviating from its intended use could lead to damage not only to the battery but also to connected equipment.

## Secure Storage

Store the battery in a place that is safely out of reach from children and pets. Inappropriate handling of the battery by them could result in severe injuries or potentially fatal accidents.

## Professional Handling

Any disassembly, modification, or repair attempts on the battery should be strictly avoided and left to qualified professionals. Unauthorized tampering can lead to hazards such as fires, electric shocks, or injuries.

## Temperature Constraints

Using the battery outside its operational temperature range of  $-20^{\circ}\text{C}$  to  $60^{\circ}\text{C}$  ( $-4^{\circ}\text{F}$  to  $140^{\circ}\text{F}$ ) can lead to diminished performance and increase safety risks.

## Charger Compatibility

Only utilize chargers that are expressly designed for  $\text{LiFePO}_4$  batteries. Incompatible chargers can cause fires, electric shocks, or damage the battery.

## Charging Oversight

Closely monitor the battery during charging. Refrain from overcharging or undercharging the battery, as it can negatively impact its lifespan and efficacy. Disconnect the charger once the battery is fully charged to avoid overcharging.

## **Fire Extinguishing Methods**

If a fire involving the battery occurs, use a Class D fire extinguisher, sand, or dry powder for extinguishing. Do not use water.

## **Responsible Disposal**

Dispose of the battery in accordance with local environmental regulations and guidelines. Do not incinerate or include it in household waste. Consult local authorities for appropriate disposal procedures.

## **Additional Safety Measures**

- Always handle the battery with caution to avoid physical impacts or drops.
- Ensure that the battery is connected correctly in terms of polarity to any devices or chargers.
- Periodically check the battery for any signs of damage, wear, or unusual behavior. If anything abnormal is detected, cease usage immediately and reach out to customer support for guidance.

# Installation Guide

Proper installation of your 12460ES is essential to ensure optimal performance and safety. Follow these installation instructions to set up your battery correctly:

## Location

Choose a well-ventilated, dry location for installing the battery. Avoid areas prone to moisture, direct sunlight, or extreme temperatures.

## Ventilation

Good airflow is necessary to dissipate any heat generated by the battery during charging and discharging processes. Adequate ventilation helps in maintaining optimal operating temperatures, thereby enhancing the battery's efficiency and longevity.

## Dry Environment

The installation area should be free from moisture. Batteries are sensitive to moisture and humidity, which can lead to corrosion, increased internal resistance, or in extreme cases, short-circuiting. A dry environment minimizes these risks and contributes to the safe operation of the battery.

## Avoid Direct Sunlight

Prolonged exposure to direct sunlight can significantly increase the battery's temperature, potentially leading to overheating. Overheating can accelerate the degradation of the battery cells and reduce overall performance and lifespan.

## Stable Temperature Conditions

While our batteries are designed to operate within a range of temperatures, extreme conditions should be avoided. Installation in an area that avoids significant temperature fluctuations helps in maintaining the structural integrity and functional efficiency of the battery. Extreme cold can reduce the battery's ability to hold a charge, while extreme heat can lead to faster chemical degradation inside the battery.

## Accessibility

Choose a location where the battery is easily accessible for maintenance, inspection, and, if necessary, replacement. This ensures that any required upkeep can be performed safely and conveniently.

## Safety Compliance

Ensure that the chosen location complies with local safety codes and regulations. This includes considering factors like clearance from flammable materials and ease of emergency access.

## Mounting

Securely mount the battery in a stable position using appropriate mounting hardware. Ensure the mounting surface can support the weight of the battery and any associated equipment.

## Orientation

Install the battery in an upright position to ensure proper operation.

## Epoch Li-Ion App

Download and install the Epoch Li-Ion app from the App Store or Google Play.

- Allow access to Bluetooth when prompted.

**Note:** Android 10+ requires location services to be enabled for fine Bluetooth scanning.

[App Store \(iOS\)](#)



[Google Play \(Android\)](#)





# Connection Guide

## Ensuring Correct Polarity

When connecting the 12460ES to your system, it's imperative to match the polarity correctly. The positive (+) terminal of the battery should align with the positive (+) terminal of the load or device, and similarly, the negative (-) terminals should be connected. This ensures safe and effective operation of your system.

## Series and Parallel Connections

The 12460ES batteries can be configured in series, parallel, or a hybrid of both, depending on your voltage and capacity requirements.

### Series Connections

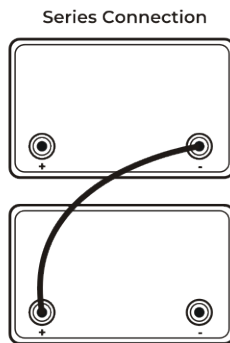

#### Voltage Increase

In a series setup, the voltages of each battery add up. For instance, connecting two 12460ES batteries in series results in a combined voltage of 24V (12V + 12V).

#### Capacity Maintenance

The total capacity in Ah remains equivalent to that of a single battery.

#### Use Cases

Ideal for applications requiring higher voltage, such as 24V power systems.

## Parallel Connections

### Voltage Consistency

When connected in parallel, the overall voltage remains the same as a single battery (12V) even when multiple batteries are connected.

### Capacity Increase

The total capacity is the sum of the individual batteries. For example, three 12460ES batteries in parallel yield a total capacity of 1,380Ah.

### Use Cases

Suitable for scenarios requiring higher capacity or extended runtime without increasing the voltage.

## Busbar System

Involves using a robust conductor to connect all positive terminals to one busbar and all negative terminals to another.

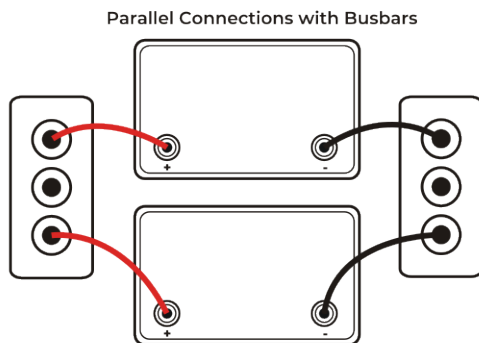

### Advantages

Promotes equal resistance and uniform charging/discharging, simplifies adding more batteries, reduces voltage drop, and facilitates battery isolation and replacement.

### Considerations

May require more space and custom busbars depending on the setup.

# Daisy-Chaining

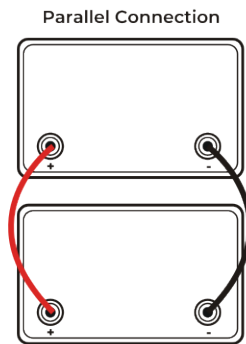

Connects the positive terminal of one battery to the negative terminal of the next.

## Advantages

Simpler implementation, especially in smaller systems or space-constrained areas, and generally requires fewer materials.

## Considerations

Can result in higher resistance for batteries further from the power source, leading to uneven charging/discharging, and adding more batteries might be cumbersome.

## Best Practices

For systems with multiple batteries, a busbar approach is generally preferred, especially in setups needing high reliability and balanced charging/discharging. Daisy-chaining is more suited for simpler, smaller systems but requires careful monitoring to ensure even charging and discharging.

# Series-Parallel Connections

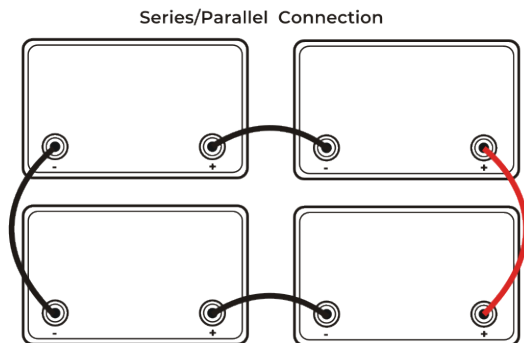

## Combining Methods

Increase both voltage and capacity by creating series strings of batteries, then connecting these strings in parallel.

## Configuration Example

Two strings of two 12460ES batteries in series (24V and 460Ah each) can be connected in parallel for a combined output of 24V and 920Ah.

## Important Considerations

### Compatibility

Use identical batteries in terms of voltage, capacity, and type to prevent uneven charging and extend the battery pack's life.

### Safety Precautions

Properly fuse each battery or string to protect against short circuits.

## Terminal and Cable Management

### Terminal Inspection

Regularly inspect battery terminals for any signs of damage and keep them clean.

### Cable Routing

Ensure cables are routed away from sharp edges and heat sources to prevent damage.

## **Overcurrent Protection**

Install appropriate fuses or circuit breakers in the circuit for safety.

## **Fuses and Circuit Breakers**

### **Choosing the Right Protection**

Determine the maximum operating current and select a fuse or circuit breaker with a rating of 125% to 150% of this current.

### **Voltage Rating**

Ensure the voltage rating of the protection device is equal to or greater than the battery's voltage.

### **Type Selection**

Choose between slow-blow fuses, fast-acting fuses, thermal circuit breakers, magnetic circuit breakers, or hybrid types based on your system's requirements.

## **Testing and Professional Assistance**

### **System Testing**

After installation, conduct a thorough system test to confirm proper operation and compatibility.

### **Seeking Help**

If you encounter difficulties or have doubts about any part of the installation process, consult a qualified technician or electrician for assistance.

# Charging Guide

Proper charging procedures are crucial to maximizing the performance, lifespan, and safety of your 12460ES. Follow these charging instructions to ensure optimal charging efficiency and battery health:

## Initiate Charge

### Power Activation

Begin by pressing the power button on the top of the 12460ES. This action powers up the battery and readies it for charging.

### Visual Indicator

Upon activation, a bright blue LED will illuminate, signaling that the battery is active and prepared to accept a charge.

## Compatible Chargers

Use only chargers specifically designed for LiFePO<sub>4</sub> batteries. Incompatible chargers can lead to serious risks like fire, electric shock, or damage to the battery.

## Charging Parameters

### Specific Voltages

Follow these specified charging voltages to ensure optimal charging:

- Bulk Voltage: 14.2V
- Absorption Voltage: 14.2V
- Float Voltage: 13.6V

### Voltage and Current Limits

Never exceed the maximum voltage or current ratings to prevent overcharging or damage.

## Charge Control

Opt for chargers equipped with charge control features, including overcharge protection and temperature compensation, for a safe and efficient charging process.

## **Initial Full Charge**

Before first use, fully charge the battery with a compatible charger, adhering to the recommended charging parameters.

## **Charging Process**

### **Correct Polarity**

Ensure proper polarity when connecting the battery to the charger.

### **Active Monitoring**

Watch the charging process closely and disconnect the charger once the battery is fully charged.

## **Charging Environment**

Charge the battery in a well-ventilated area away from flammable materials, heat sources, and moisture. Ensure adequate airflow around the battery during the charging process.

## **Temperature Management**

### **Optimal Range**

Charge within the recommended temperature range of -20°C to 60°C (-4°F to 140°F) to maintain charging efficiency and preserve battery lifespan.

### **Extreme Temperature Avoidance**

Refrain from charging in very high or low temperatures, as this can impact the efficiency and longevity of the battery.

## **Safety Precautions**

Always follow safety precautions when charging the battery, including wearing appropriate personal protective equipment and avoiding direct contact with exposed terminals.

## **Monitoring**

Regularly monitor the charging process and battery condition to ensure proper operation. If any abnormalities or issues are detected, discontinue charging immediately and contact customer support for assistance.

# Usage Guide

Follow these guidelines to ensure that your 12460ES operates efficiently and safely, maximizing its potential and lifespan. Regular adherence to these practices will help maintain the battery's optimal condition and ensure reliable performance.

## Activating Discharge

### Power On

Initiate the discharge process by pressing the power button atop the 12460ES.

### Visual Confirmation

A bright blue LED will illuminate upon activation, signaling that the battery is ready discharging.

## Optimal Operating Conditions

### Temperature Range

Operate the battery within  $-20^{\circ}\text{C}$  to  $60^{\circ}\text{C}$  ( $-4^{\circ}\text{F}$  to  $140^{\circ}\text{F}$ ). However, for optimal performance and extended lifespan, maintain a temperature range of  $15^{\circ}\text{C}$  to  $25^{\circ}\text{C}$  ( $59^{\circ}\text{F}$  to  $77^{\circ}\text{F}$ ).

### Avoid Extremes

Exposure to extreme temperatures can detrimentally affect the battery's performance and durability.

## Managing Discharge Depth

### Shallow Discharges

Aim to minimize deep discharges. Regularly discharging below 20% SOC (State of Charge) or 12.8V can shorten the battery's lifespan.

## Load Management

### Current Limits

Ensure that the load connected to the battery does not surpass the maximum continuous discharge current of 200A to avoid overloading and potential damage.



## **Storage Practices**

### **Ideal Conditions**

When not in use, store the battery in a cool, dry environment, preferably within 15°C to 25°C (59°F to 77°F).

### **Charge State for Storage**

For long-term storage, maintain at least a 50% SOC and periodically recharge to preserve battery health.

## **Standby and Backup Use**

### **Readiness Testing**

Regularly test and maintain the battery when used for standby or backup purposes to ensure it's fully functional during power outages or emergencies.

## **Regular Maintenance**

### **Inspections and Testing**

Conduct visual checks and test voltage and capacity regularly. Promptly address any abnormalities to avert potential issues.

## **Disconnection When Idle**

### **Preventing Self-Discharge**

Disconnect the battery from the load and power it off during extended periods of non-use to prevent self-discharge and maintain battery life.

## **Careful Handling**

### **Avoid Damage**

Handle the battery carefully to prevent any damage to the casing or internal components. Avoid drops and rough treatment.

## **Adhering to Safety Precautions**

### **Safe Operation**

Always observe safety measures while handling or using the battery. This includes wearing suitable protective gear and avoiding contact with exposed terminals.

## **Professional Consultation**

### **Seek Expert Advice**

For any uncertainties regarding the battery's usage or compatibility with specific applications, it's advisable to consult with a qualified technician for professional guidance and assistance.

# Maintenance Guide

Maintaining your 12460ES is vital for ensuring its long-term performance and reliability.

## Regular Visual Inspections

### Surface and Structure Check

Regularly examine the battery's casing, terminals, and wiring for any signs of wear, damage, or corrosion. This includes checking for cracks, bulges, or leaks.

### Immediate Action

If any abnormalities are noticed, take immediate steps to address them to prevent further issues.

## Terminal and Connector Maintenance

### Cleaning Process

Use a soft brush or cloth along with a mild cleaning solution to gently clean the terminals and connectors, removing dirt, dust, or corrosion.

## Securing Connections

### Tightness Check

Regularly ensure that all connections, especially terminal connections, are tight and secure. Loose connections can lead to voltage drops, poor performance, or even safety hazards.

### Re-tightening Procedure

If any looseness is detected, carefully tighten the connections without over-tightening, which can damage the terminals.

## Voltage Monitoring

### Regular Testing

Use a reliable multimeter or battery tester to periodically test the battery's voltage.

### Voltage Comparison

Compare the measured voltage with the expected values to ensure the battery is operating correctly.

## Capacity Evaluation

Perform capacity tests to evaluate the battery's health and efficiency.

## **Temperature Checks**

### **Operational Heat Monitoring**

Keep an eye on the battery's temperature during charging and discharging cycles.

### **Temperature Regulation**

Avoid operation in extreme temperatures to maintain battery health and prevent performance degradation.

## **Implement Preventive Maintenance**

### **Scheduled Checks**

Set up a preventive maintenance routine, including regular inspections, cleaning, and testing.

### **Maintenance Records**

Keep a log of all maintenance activities, observations, and any actions taken for future reference and tracking.

## **Optimal Storage Environment**

Ensure the battery is stored in a clean, dry place, away from direct sunlight, moisture, or extreme temperature variations.

## **Adherence to Safety Practices**

### **Safety Gear**

Always use the appropriate personal protective equipment when performing maintenance tasks.

### **Avoid Direct Contact**

Be cautious to avoid direct contact with exposed terminals or damaged parts of the battery.

## **Expert Consultation**

If you face any uncertainties or complex issues, or require assistance with more technical maintenance tasks, don't hesitate to contact a qualified technician for professional support.

# Troubleshooting Guide

Follow these troubleshooting steps to identify and resolve common problems:

## Battery Not Charging

### Connection Check

Ensure that the charger is properly and securely connected to the battery terminals, observing the correct polarity.

### Charger Compatibility and Function

Confirm that the charger is operational and specifically designed for LiFePO<sub>4</sub> batteries.

### Power Source Inspection

Make sure the power source for the charger is active and supplying the required voltage.

## Low Voltage or Capacity

### Load Disconnect

Remove any connected loads and measure the battery's voltage to check if the issue is due to excessive discharge.

### Visual Battery Inspection

Examine the battery for any visible signs of damage, leaks, or other unusual conditions.

### Capacity Assessment

Perform a detailed capacity test to evaluate the battery's current health and performance levels.

## Overheating Issues

### Temperature Range Compliance

Confirm that the battery is being operated within its specified temperature range.

### Ventilation

Ensure there is sufficient airflow around the battery to effectively dissipate heat.

### Load Management

If overheating occurs during discharge, consider reducing the load to alleviate stress on the battery.

## **Short Circuit Concerns**

### **Load Disconnection**

Immediately disconnect all loads if a short circuit is suspected.

### **Inspection of Terminals and Wiring**

Check for any signs of damage, corrosion, or looseness in the wiring and terminals.

### **Continuity Testing**

Use a multimeter to check for continuity between the positive and negative terminals to identify a potential short circuit.

## **Abnormal Battery Behavior**

### **Behavioral Observation**

Monitor how the battery behaves during both charging and discharging cycles for any out-of-the-ordinary symptoms.

### **Behavior Documentation**

Record any abnormal behavior such as voltage instability, excessive heat generation, or unexpected power losses.

### **Seek Technical Support**

Reach out to technical support for expert advice on diagnosing and remedying the issue.

## **Failure to Hold Charge**

### **Charging Parameter Verification**

Ensure the battery is being charged with the correct voltage and current settings.

### **Capacity Testing**

Conduct a capacity test to determine if the battery effectively holds its rated capacity.

### **Consider Battery Age**

Take into account the age and usage history of the battery, as its ability to hold a charge may diminish over time.

## **Excessive Self-Discharge**

### **Load Disconnection**

Ensure that all loads are disconnected when the battery is not in active use.

### **Terminal Maintenance**

Clean the terminals and connectors to ensure proper contact and reduce self-discharge.

### **Current Draw Measurement**

Isolate the battery and measure the current draw to detect any parasitic loads.

## **Erratic Behavior**

### **Environmental Factors**

Ensure the battery is not exposed to extreme conditions like high temperatures or moisture.

### **Connection Security**

Check all terminal connections to prevent intermittent connectivity issues.

### **Component Testing**

Evaluate individual components, such as chargers or connected devices, to pinpoint the source of erratic behavior.

## **Seeking Professional Assistance**

If the troubleshooting steps do not resolve the problem, or if you are unsure about performing any of these tasks, it is advisable to seek help from a qualified technician. Professional assistance ensures accurate diagnosis and safe, effective solutions.

# Warranty Information

Please review the following warranty information outlining the coverage, terms, and conditions of your battery's warranty:

## Warranty Terms

### Duration of Coverage

The battery is accompanied by a limited warranty, which is active from the date of purchase and lasts for a period not exceeding 11 years.

### Coverage Scope

- This warranty specifically addresses manufacturing defects. It includes issues such as faulty components, errors in assembly, or structural irregularities that affect the performance and functionality of the battery.
- The warranty is designed to cover defects that occur under normal usage conditions and is an assurance of the product's quality and reliability.

## Exclusions from Warranty

### User-Related Damages

The warranty does not cover damages that arise due to misuse, abuse, neglect, or improper handling and maintenance of the battery.

### Unauthorized Modifications

Any form of modification, alteration, or tampering with the battery voids the warranty completely.

### External Causes

Damages caused by external factors like accidents, natural disasters (such as floods, earthquakes), or unauthorized repairs are not included in the warranty.

### Non-Approved Accessories

Using accessories or chargers that are not approved by Epoch Batteries may lead to damages that are not covered under this warranty.



# Warranty Claim Procedure

## Initiating a Claim

To start a warranty claim, reach out to our customer support team. Provide your proof of purchase and a detailed account of the issue you're experiencing.

## Assistance and Guidance

Our customer support team will walk you through the claim process and give you instructions for returning the defective product, if necessary.

## Inspection and Resolution

Upon receipt and inspection of the product, we will determine if it's eligible for warranty coverage. Depending on the outcome, we will undertake repair, replacement, or provide a refund, as applicable.

# Limitation of Liability

## Extent of Responsibility

Our liability under this warranty is strictly limited to repairing, replacing, or refunding the defective product, at our discretion.

## Exclusion of Indirect Damages

We are not liable for any indirect damages that arise from using or the inability to use the battery. This includes, but is not limited to, data loss, lost profits, or personal injuries.

# Consumer Rights

## Legal Rights

This warranty provides you with specific legal rights. Additionally, you may have other rights that vary from jurisdiction to jurisdiction.

## Statutory Rights

Your statutory rights as a consumer remain unaffected by this warranty.

# Warranty Support Contact

## Support Team

For any warranty claims, questions, or assistance, you can contact the Epoch Batteries customer support team at [Epoch Batteries \(Support\)](#)

## **Maintaining Your Warranty**

### **Proof of Purchase**

Always retain your proof of purchase and a copy of this warranty document for future reference.

### **Queries and Assistance**

If you have any doubts or need clarification about the warranty coverage or the claim process, feel free to reach out to us for support.

We at Epoch Batteries are proud of the quality and reliability of our products. We are dedicated to providing exceptional customer service and stand firmly behind our batteries. Thank you for choosing Epoch Batteries as your trusted energy solution.