



SPECIFICATION SHEET  
**GC2-R-B4830**  
BATTERY SYSTEM

Battery system: GC2-R-B4830 Capacity: 150Ah

Built-in Smart Battery Management System (BMS)

**ELECTRICAL SPECIFICATIONS**

Voltage:	51.2V Nominal
Chemistry:	LiFePO4
Max Charge Voltage:	57.6V
Operating Voltage Range:	40.0 - 57.6V
Ah Capacity:	150Ah
Cell configuration:	16S
Max Continuous Discharge Amps:	300A
Max Discharge Peak Current Amps:	500A (10 Seconds)
Max Charge Current Amps:	150A
Charge Temp Range:	0°C (32°F) / 55°C (131°F)
Discharge Temp Range:	0°C (32°F) / 55°C (131°F)
Storage Temp:	0°C (32°F) / 30°C (86°F) (<6 Months)
Weight:	33 (LBS) (per module x 5)
Depth Inches:	7.1 (per module x 5)
Width Inches:	10.2 (per module x 5)
Height Inches:	10.7 (per module x 5)
Safety Features:	BMS (Battery Management System) Over Voltage, Under Voltage, Over-Current, Short Circuit, Over Temperature, Under Temperature
Series   Parallel:	Max (10) in Parallel = 300 Amp Hours

**DIMENSIONS**

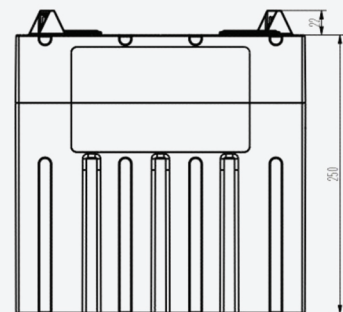
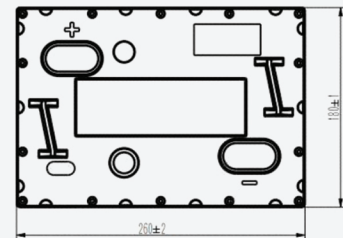

- ✓ TROJAN T-105 EXACT REPLACEMENT
- ✓ MODULE DESIGN, GC2 SIZE
- ✓ IP67 - WATERPROOF
- ✓ STACK FOR INCREASED POWER OUTPUT
- ✓ CONNECT UP TO 10 IN PARALLEL (300AH)
- ✓ 48V GOLF CARTS

**INSTALLATION GUIDE**

