

by SoundOff Signal

intersecor

INTERSECTOR LED LIGHT

- #ENT3B3(xxx) - BLACK HOUSING
- #ENT3C3(xxx) - CHROME HOUSING
- #ENT3W3(xxx) - WHITE HOUSING
- #PNT3DGBB DECK/ GRILLE BRACKET, BLACK

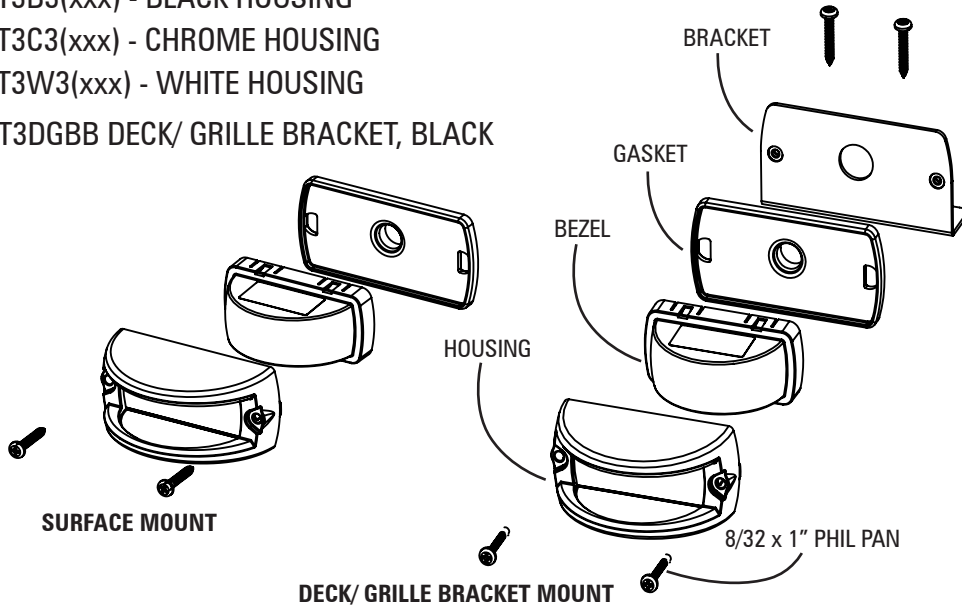

⚠ WARNING

Please see last page for Technical Specifications

- HIGH CURRENT interconnects must be properly terminated. Poor crimp quality can cause heat build-up and fire. Follow crimp connector manufacturer instructions.
- DO NOT install this product or route any wires in the Air Bag Deployment Zone. Refer to vehicle Owner's Manual for deployment zones.
- Unit may become hot to touch during normal operation.
- Failure to properly install connectors, fuses or wiring may cause vehicle failure or fire.
- Installation must only be performed by trained technician. Installer must determine vehicle wiring configuration and proper integration of system.
- Use proper wire gauge. All power wires connecting to positive (+) or negative (-) battery terminal or local chassis ground (-) must be sized to supply at least 125% of max. current and properly fused at power source.
- Install protective grommets when routing wire through firewall or metal.

SURFACE MOUNT INSTALLATION:

1. Establish a position on the vehicle on a level surface. Orient the light output level on the horizon.
2. Use the gasket provided as a template to mark locations of wire and mounting screws
3. Use a 5/8" diameter drill for the wire holes
4. Size pilot holes for mounting screws appropriately.
5. Fasten light using bezel and mounting screws. Do not torque mounting screws beyond 20 in - lbs.

DECK/ GRILLE BRACKET INSTALLATION: (PURCHASED SEPARATELY)

1. Slide wire from Bezel through center access hole in the gasket and bracket.
2. Next, position the Housing over the Bezel and align the holes with the bracket.
3. Lastly, using the supplied 8-32 x 1" screws fasten the assembly lightly. Do not torque mounting screws beyond 20 in - lbs.
4. Establish a position on the vehicle on a level surface. Orient the light output level on the horizon.
5. Use the bracket provided as a template to mark locations of mounting screws.
6. Size pilot holes for mounting screws appropriately.
7. Fasten light using bezel and mounting screws. Do not torque mounting screws beyond 20 in - lbs.

⚠ WARNING

This product contains high intensity LED devices. To prevent eye damage, DO NOT stare into the light beam at close range.

NOTICE:

Installers and users must comply with all applicable federal, state and local laws regarding use and installation of warning devices.

*Improper use or installation may void warranty coverage. To review our Limited Warranty Statement & Return Policy for this or any SoundOff Signal product, visit our website at www.soundoffsignal.com/sales-support. If you have questions regarding this product, contact **Technical Services**, Monday - Friday, 8 a.m. to 5 p.m. at 1.800.338.7337 (press #4 to skip the automated message). Questions or comments that do not require immediate attention may be emailed to techservices@soundoffsignal.com.*

OPERATION:

For details on operation see page with 'Flash Patterns' table on page 4.

IMPORTANT:

Supply power through a 3A fuse. For Flashing mode, refer to function tables 1, 2 and 3 on page 3. For slave/Remote Node functionality such as when connected to Blueprint, permanently connect the Green wire to ground. Refer to Remote Node functionality table on page 5.

Insulate all connections.

WIRE HOOK-UP TABLE

WIRE COLOR:	FUNCTION:
RED	Table pg. 3
BLACK	Ground
GREEN**	Sync2 or Remote Node Function*
WHITE to GROUND	Wire Function See Table pg. 2
WHITE to POWER	Table pg. 3
RED/WHITE	Table pg. 3

** To sync multiple Intersector or nFORCE® lights connect the green wire from each light together.
*Will NOT work w/ other sync products such as Ghost®, LED3, & 4-wire Intersector.

OPERATIONAL CONNECTIONS:

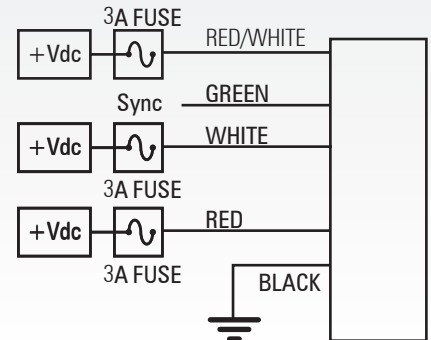

SoundOff Signal
Smart Design.

1.800.338.7337 / www.soundoffsignal.com

SUPERIOR CUSTOMER RELATIONSHIPS. SMARTLY DESIGNED LIGHTING & ELECTRONIC SOLUTIONS. ENT3(x)3(x)_5 Wire_9-32Vdc 12.17



INTERSECTOR LED LIGHT

ADVANCE PATTERN

Flash pattern can only be changed when the LED module is in a flashing mode (disabled in cruise or steady ON functions). When the light is flashing, momentarily touch the white wire to ground for >250ms and <1s (light will go steady high) then release. The flash pattern will advance to the next pattern. If the light module was at the last pattern, the pattern will reset to the 1st pattern.

BACKUP PATTERN

This function is only valid when the LED module is in a flashing mode (disabled in cruise or steady ON functions). When the light is flashing, momentarily touch the white wire to ground for >1s and <2s (light will go steady high, steady low) then release. The flash pattern will backup to the previous pattern. If the light module was at the first pattern, the pattern will change to the last pattern on the list.

COLOR SWAP

This function is only valid for dual color light modules and can only be changed when the light module is in a flashing mode (disabled for single color modules and when light module is operating in cruise or steady ON functions). When the light is flashing, momentarily touch the white wire to ground for >2s and <3s (light will go steady high, steady low, off) then release. The light module will switch between Color Swap OFF and Color Swap ON. When Color Swap is OFF, the 1st color will flash 1st on a dual color pattern. When Color Swap is ON, the 2nd color will flash 1st on a dual color pattern.

SIMULTANEOUS/ALTERNATE

This function can only be changed when the LED module is in a flashing mode (disabled in cruise or steady ON functions) and only has an effect when at least 2 LED modules have the green sync wire connected together. When the light is flashing, momentarily touch the white wire to ground for >3s and <4s (light will go steady high, steady low, off, steady high) then release. The light module will switch between Simultaneous and Alternate each time this sequence is done. To have light modules flash simultaneously, both light modules need to be set to the same sequence type (Set-Up Table). To have light modules flash alternately, the light modules need to be set to different sequence types (Set-Up Table).

PATTERN RESET

This function is only valid when the LED module is in a flashing mode (disabled in cruise or steady ON functions). When the light is flashing, momentarily touch the white wire to ground for >5s and <6s (light will go steady high, steady low, off, steady high, steady low, off) then release. The flash pattern will reset to the 1st pattern in the list.

FACTORY RESET

This function is only valid when the LED module is in a flashing mode (disabled in cruise or steady ON functions). When the light is flashing, momentarily touch the white wire to ground for >6S and <7S (light will go steady high, steady low, off, steady high, steady low, off, steady high) then release. The LED module will reset to: pattern=1, Function Table=1, Color Swap=OFF, Simultaneous.

SETUP TABLE			
SECONDS		USER INTERFACE	
FROM	TO	VISUAL FEEDBACK	ACTION TAKEN
0	1	STEADY-HIGH (60%)	FORWARD ONE PATTERN
1	2	STEADY-LOW (30%)	BACKWARD ONE PATTERN
2	3	OFF	COLOR SWAP (OFF OR ON)
3	4	STEADY - HIGH (60%)	SEQUENCE TYPE: SIMULTANEOUS OR ALTERNATE
4	5	STEADY - LOW (30%)	SET FUNCTION TABLE
5	6	OFF	RESET TO PATTERN 1
6	7	STEADY-HIGH (60%)	FACTORY RESET (PATTERN 1, COLOR SWAP: OFF, SIMULTANEOUS) SEPARATE COLOR CONTROL: OFF
If held longer than 7 seconds, the light will go back to flashing the current pattern and no action will be taken.			





INTERSECTOR LED LIGHT

FUNCTION TABLES

Changing the function table is only enabled when the LED module is in a flashing mode (disabled in cruise or steady ON functions). The functional operation of the LED module can be changed while applying the +V to the Red wire with the black wire connected to ground. When the light is flashing, momentarily connect the White wire to ground for >4S and <5S (light will go steady high, steady low, off, steady high, steady low) then release. The function table will now advance to the next table (table 1 to table 2, table 2 to table 3, or table 3 to table 1). Repeat above process until required function table is active.

FUNCTION TABLE 1					
WIRE			LIGHT		
RED	R/W	WHT	SINGLE	DUAL	TRI
+9-32V			FLASH	FLASH DUAL	FLASH TRI
	+9-32V		CRUISE	STEADY CLR 2	STEADY CLR 3
+9-32V	+9-32V		FLASH	STEADY CLR 2	STEADY CLR 3
		+9-32V	NO OP	NO OP	NO OP
+9-32V		+9-32V	LOW PWR FLASH	FLASH CLR 1	FLASH CLR 1
	+9-32V	+9-32V	CRUISE	FLASH CLR 2	FLASH CLR 2
+9-32V	+9-32V	+9-32V	LOW PWR FLASH	FLASH DUAL	FLASH CLR 3

FUNCTION TABLE 2					
WIRE			LIGHT		
RED	R/W	WHT	SINGLE	DUAL	TRI
+9-32V			FLASH	FLASH CLR 1	FLASH DUAL
+9-32V		+9-32V	CRUISE	FLASH DUAL	FLASH TRI
	+9-32V		STEADY CLR 1	STEADY CLR 2	STEADY CLR 3
	+9-32V	+9-32V	STEADY CLR 1	STEADY CLR 2	STEADY CLR 3
+9-32V	+9-32V	+9-32V	STEADY CLR 1	STEADY CLR 2	STEADY CLR 3
		+9-32V	NO OP	NO OP	NO OP
+9-32V	+9-32V		STEADY CLR 1	STEADY CLR 2	STEADY CLR 3

FUNCTION TABLE 3					
WIRE			LIGHT		
RED	R/W	WHT	SINGLE	DUAL	TRI
+9-32V			FLASH	FLASH DUAL	FLASH TRI
	+9-32V		FLASH LOW PWR	FLASH DUAL LOW PWR	FLASH TRI LOW PWR
+9-32V	+9-32V		FLASH LOW PWR	FLASH DUAL LOW PWR	FLASH TRI LOW PWR
		+9-32V	NO OP	NO OP	NO OP
+9-32V		+9-32V	FLASH LOW PWR	FLASH DUAL LOW PWR	FLASH TRI LOW PWR
	+9-32V	+9-32V	FLASH LOW PWR	FLASH DUAL LOW PWR	FLASH TRI LOW PWR
+9-32V	+9-32V	+9-32V	FLASH LOW PWR	FLASH DUAL LOW PWR	FLASH TRI LOW PWR



intersector

INTERSECTOR LED LIGHT

SYNC 2

Synchronizing the flashing of multiple light modules is accomplished by connecting the Green wires of different light modules together. Up to 24 light modules can be connected for synchronized flashing. All light module flash patterns must be set to the same flash pattern # to ensure proper operation. Refer to the Sequence Type section in Set-Up table to setup light modules to flash in alternate or simultaneous flash pattern.

NOTE: Will NOT work with Sync products such as Ghost, LED3, 4-wire Intersector.

FLASH PATTERNS			
PATTERN #	SINGLE COLOR	DUAL COLOR / TRI COLOR	SAE COMPLIANT
1		QUINT	x
2		WARP	x
3		INTER-CYCLE	x
4		DOUBLE	
5		QUAD	x
6		POWER PULSE	x
7		ROAD RUNNER	x
8		Q-SWITCH	x
9		STEADY-BURN / ROADRUNNER (SEQUENCE TYPE 1: STEADY BURN, SEQUENCE TYPE 2: ROADRUNNER)	x
10		STEADY-BURN DRIVER / TITLE 13 QUAD (SEQUENCE TYPE 1: STEADY BURN, SEQUENCE TYPE 2: TITLE 13 QUAD)	x
11		QUAD 2	x
12		DOUBLE 2	x
13		RANDOM 1	x
14		RANDOM 2	x



INTERSECTOR LED LIGHT

REMOTE MODE: FOR USE WITH bluePRINT SYSTEM ONLY

Connecting the Green wire to ground before applying power to the Red or Red/White wires will place the LED module into remote mode and the light output color will be directly controlled by the input wires as shown below.

For Cruise mode or Low Power control of the LED module, the signal to the control wires must be 100 +/- 2Hz using the duty cycle inputs listed below to produce the light output.

INTERSECTOR LED LIGHT REMOTE NODE FUNCTIONALITY							
Red Wire	Red/Wht Wire	Single Color		Dual Color		Tri Color	
		Color Swap=OFF	Color Swap=ON	Color Swap=OFF	Color Swap=ON	Color Swap=OFF	Color Swap=ON
Cruise	-	Cruise Color 1		Cruise Color 1	Cruise Color 2	Cruise Color 1	Cruise Color 2
-	Cruise			Cruise Color 2	Cruise Color 1	Cruise Color 2	Cruise Color 1
Cruise	Cruise			Cruise Color 2	Cruise Color 1	Cruise Color 3	Cruise Color 3
Flash	-	Flash Color 1		Flash Color 1	Flash Color 2	Flash Color 1	Flash Color 2
-	Flash			Flash Color 2	Flash Color 1	Flash Color 2	Flash Color 1
Flash	Flash			Flash Color 2	Flash Color 1	Flash Color 3	Flash Color 3
Steady ON	-	Steady ON Color 1		Steady ON Color 1	Steady ON Color 2	Steady ON Color 1	Steady ON Color 2
-	Steady ON			Steady ON Color 2	Steady ON Color 1	Steady ON Color 2	Steady ON Color 1
Steady ON	Steady ON			Steady ON Color 2	Steady ON Color 1	Steady ON Color 3	Steady ON Color 3
Cruise	Flash			Flash Color 2/Cruise Color 1 during OFF cycle of Flash	Flash Color 1/Cruise Color 2 during OFF cycle of Flash		
Cruise	Steady ON			Steady ON Color 2	Steady ON Color 1		
Flash	Steady ON			Steady ON Color 2	Steady ON Color 1		

CRUISE MODE DUTY CYCLE (@ 100Hz)	
Input	Light Output
40%	OFF
50%	5%
60%	10%

LOW POWER FLASH D.C. (@ 100Hz)	
Input	Light Output
70%	30%
80%	40%
90%	50%





INTERSECTOR LED LIGHT

OVER-VOLTAGE PROTECTION

When an over-voltage condition is detected, the module will flash an over-voltage warning pattern of 50mS ON/950mS OFF to alert of the over-voltage condition and protect the electronics from damage due to heat/voltage.

THERMAL COMPENSATION PROTECTION

The LED module is designed to provide maximum power output while providing protection to the electronic components by reducing the output power at extreme temperatures.

TECHNICAL SPECIFICATIONS	
INTERSECTOR	
Single Mount Dimensions:	2.9" (74 mm) W x 1.9" (48 mm) H x 2.9" (74 mm) D
Input Voltage:	9 - 32 Vdc
AFTER POWER IS ON, touching the WHITE wire to the ground will allow you to change various settings on the module. (refer to pages 3 & 4)	

	Input Voltage:		9-32Vdc	
	SINGLE / DUAL COLOR CURRENT CONSUMPTION (Amps)			
	12.8Vdc		25.6Vdc	
	Peak	Average	Peak	Average
Red	1.00	0.60	0.50	0.30
Amber, Blue, Green or White	1.30	0.80	0.65	0.40
	TRI COLOR CURRENT CONSUMPTION (Amps)			
	12.8Vdc		25.6Vdc	
	Peak	Average	Peak	Average
Red	0.77	0.46	0.36	0.22
Amber, Blue, Green or White	1.00	0.60	0.50	0.30

NOTICE:

Installers and users must comply with all applicable federal, state and local laws regarding use and installation of warning devices.

*Improper use or installation may void warranty coverage. To review our Limited Warranty Statement & Return Policy for this or any SoundOff Signal product, visit our website at www.soundoffsignal.com/sales-support. If you have questions regarding this product, contact **Technical Services**, Monday - Friday, 8 a.m. to 5 p.m. at **1.800.338.7337** (press #4 to skip the automated message). Questions or comments that do not require immediate attention may be emailed to techservices@soundoffsignal.com.*

