

Best doors PS 60 Sliding Fire Door Set

The PS60 sliding fire door set is used where a large opening in a fire separation (up to 10m²) is required to be closed off in the event of a fire and/or in daily use.

The slider may be concealed behind an appropriate cavity wall. Automatic opening and closing is not currently available for Sliding Fire Doors.

The PS60 is a sliding fire door set. The door leaf can be faced in plywood or steel sheet, and is capped with steel channel to 4 edges and hung from a sliding track system.

A counterweight system, released by a fusible link or electromagnetic hold open devices that are linked to a fire detection system, closes the door leaf in the event of a fire.

For higher fire ratings and larger sized doors refer to the PS240 slider.

PS60 is not available as a smoke control door set.

The thickness of the PS60 door leaf is 65mm with an approximate leaf weight of at least 31kg/m²

Wall Type	Maximum Fire Resistance Rating Stability/Integraty/Insulation	Door Application	Max Leaf Height (mm)	Max Leaf Width (mm)
Timber Stud Wall Masonry Wall	-/60/30sm	Single	4000	3000

Notes:

The PS60 is not available as a 'pair' door set.

The maximum area per sliding door leaf is 10.5m².

Product Options

LEAF FACINGS

Plywood

Steel Sheet 0.9mm

LEAF EDGES

The leaf edges listed below are available for the PS60 door set



Folded Steel/Al Cap

HARDWARE/CLOSING SYSTEMS

A Standard Track System is supplied with this door set.

STANDARD CLOSER

Weight and pulley system with self-closure activated by fusible link in the event of fire.

ELECTROMAGNETIC CLOSING WEIGHT SYSTEM

A weight and pulley system modified for electromagnetic release is available. Closure is on fire/smoke detection activated by sensors (by others) mounted each side of the door set to lintel or ceiling.

FRAME TYPES & PROFILES

Please refer to the installation instructions for this door set for more information.

MEETING STILES

Not applicable for this door set.

WALL TYPES

Masonry

The Best doors Slider may be hung from a concrete or masonry wall either of precast concrete (thickness 100mm minimum) or grouted blockwork (thickness 190mm minimum).

Dry walls

Special wall construction is required for mounting on plasterboard walls. Please contact Best Doors for further information.

Product Optional Extras

Please contact Best Doors for information on vision panel options

Not applicable for this door set.

Not applicable for this door set.

CAVITY WALL SYSTEM

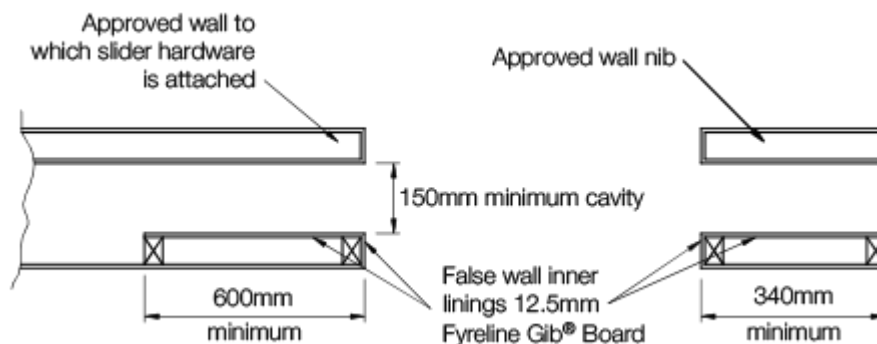

This door leaf has a thermal insulation rating (R-value) of 0.645 Km^2/W .

TECHNICAL COMPLIANCE STATEMENT

The PS60 fire door complies with the requirements of NZS 4520 *Fire-resistant door sets* when installed in accordance with Best Doors' Installation Instructions into a complying fire-resistant wall, and when fitted with approved hardware.

NZS 4520 is referenced in the New Zealand Building Code Acceptable Solutions (Appendix C 6.1.1)

Best PS60 fire doors have been successfully fire-tested in accordance with AS1530.4, as referenced in NZS 4520 and in Appendix C 5.1.1.

The fire resistance achieved by the PS60 was FRR -/60/30

The PS60 fire door will satisfy the requirements of NZBC, B2 "Durability" under conditions of use, installation and maintenance specified by Best Doors, or specific contractual guarantees, whichever are overriding.