

Best doors PR 120 Door Set -/120/60 sm Installation

WALL TYPE: **KOROK / SPEEDWALL**

FRAME TYPE: **STEEL, 1-PART**

Frame materials available:

- EGZ - 1.6 mm
- Cold rolled galvanized - 1.6 mm

Fasteners:

- Jamb fixing at 60 mm centres minimum
- 10 Gauge self tapping screws

Head Fixing (minimum):

- Single door - 2 required
- Paired door - 4 required

Wedging gap:

- 0 - 15 mm

Fire rating for unlined Speedpanel / Korok walls:

- 51 mm wall: Max. FRR -/60/30
- 64 mm wall: Max. FRR -/90/30
- 78 mm wall: Max. FRR -/120/30

Integrity rating can be increased by 30 minutes by lining the wall one or both sides, up to a max. of 120 minutes.

Frame has to be filled with plasterboard, ceramic fibre blanket or grout to achieve 30 minute insulation rating.

Please note that when using this installation method the frame has to be built into the wall. It can't be installed in a pre-formed opening.

WALL TYPE: **KOROK / SPEEDWALL**

FRAME TYPE: **STEEL, 1-PART**

Frame materials available:

- EGZ - 1.6 mm
- Cold rolled galvanized - 1.6 mm

Fasteners:

- Jamb fixing 6 sets (i.e. 12 per jamb)
- 10 x 75 mm Gauge self tapping screws

Head Fixing (minimum):

- Single door - none required
- Paired door - 1 set

Wedging gap:

- 0 - 15 mm

Fire rating for unlined Speedpanel / Korok walls:

- 51 mm wall: Max. FRR -/60/30
- 64 mm wall: Max. FRR -/90/30
- 78 mm wall: Max. FRR -/120/30

Integrity rating can be increased by 30 minutes by lining the wall one or both sides, up to a max. of 120 minutes.

Frame has to be filled with plasterboard, ceramic fibre blanket or grout to achieve 30 minute insulation rating.

PC30 to PR120 Steel Frame in Speedwall

Note: Door must be fitted at time of wall construction

Holes drilled on site at nominal 600mm centres

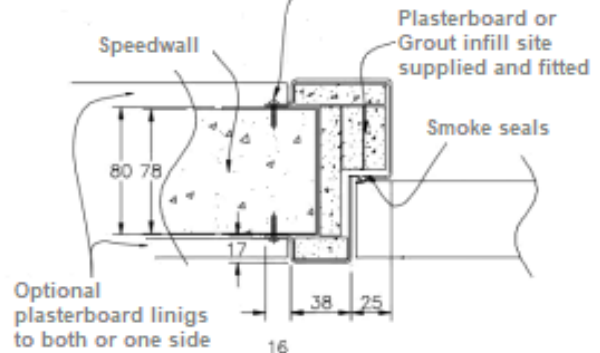

**FRAME PROFILE SHOWN IS THE ONLY PROFILE AVAILABLE FOR THIS WALL TYPE
SIZE RESTRICTION APPLY**

PR30 to PR120 Steel Frame in Speedwall

Lorient / Pyroseal to a depth of at least half gap width both sides

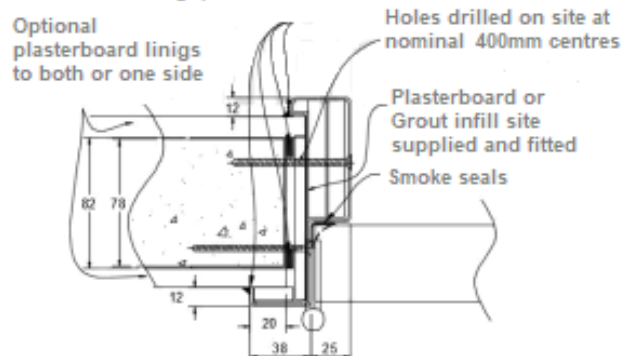

WALL TYPE: KOROK / SPEEDWALL

FRAME TYPE: STEEL, 1-PART

Frame materials available:

- EGZ - 1.6 mm
- Cold rolled galvanized - 1.6 mm

Fasteners:

- Jamb fixing 6 sets (i.e. 12 per jamb)
- 10g x 75 mm self tapping screws

Head Fixing (minimum):

- Single door - none required
- Paired door - 1 set

Wedging gap:

- 0 - 15 mm

Fire rating for unlined Speedpanel / Korok

- 51 mm wall: Max. FRR -/60/30
- 64 mm wall: Max. FRR -/90/30
- 78 mm wall: Max. FRR -/120/30

Integrity rating can be increased by 30 minutes by lining the wall one or both sides, up to a max. of 120 minutes.

Frame has to be filled with plasterboard, ceramic fibre blanket or grout to achieve 30 minute insulation rating.

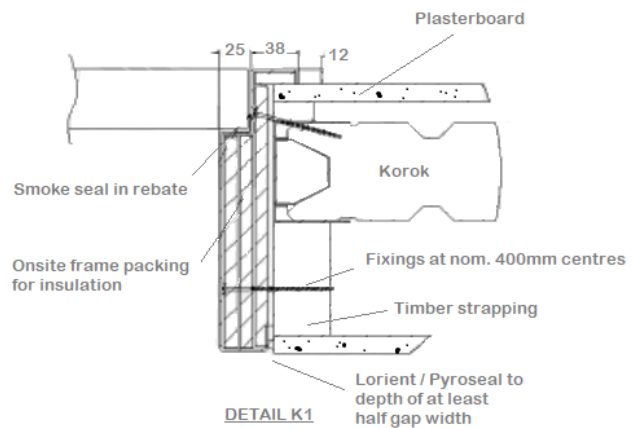

walls:

WALL TYPE: KOROK / SPEEDWALL

FRAME TYPE: STEEL, 1-PART

Frame materials available:

- EGZ - 1.6 mm
- Cold rolled galvanized - 1.6 mm

Fasteners:

- Jamb fixing 6 sets (i.e. 12 per jamb)
- 10g x 75 mm self tapping screws

Head Fixing (minimum):

- Single door - none required
- Paired door - 1 set

Wedging gap:

- 0 - 15 mm

Fire rating for unlined Speedpanel /

walls:

- 51 mm wall: Max. FRR -/60/30
- 64 mm wall: Max. FRR -/90/30
- 78 mm wall: Max. FRR -/120/30

Integrity rating can be increased by 30 minutes by lining the wall one or both sides, up to a max. of 120 minutes.

Frame has to be filled with plasterboard, ceramic fibre blanket or grout to achieve 30 minute insulation rating.

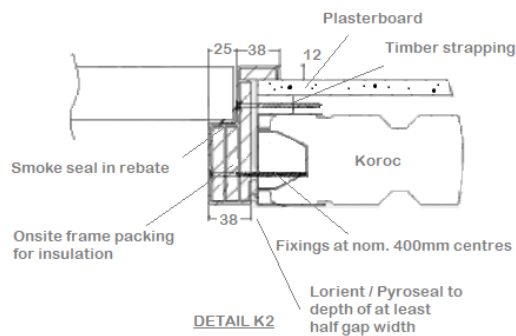

Korok

WALL TYPE: KOROK / SPEEDWALL

FRAME TYPE: STEEL, 1-PART

Frame materials available:

- EGZ - 1.6 mm
- Cold rolled galvanized - 1.6 mm

Fasteners:

- Jamb fixing 6 sets (i.e. 12 per jamb)
- 10g x 75 mm self tapping screws

Head Fixing (minimum):

- Single door - none required
- Paired door - 1 set

Wedging gap:

- 0 - 15 mm

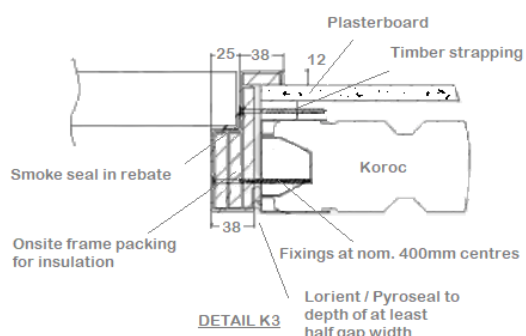

Fire rating for unlined Speedpanel / Korok walls:

- 51 mm wall: Max. FRR -/60/30
- 64 mm wall: Max. FRR -/90/30
- 78 mm wall: Max. FRR -/120/30

Integrity rating can be increased by 30 minutes by lining the wall one or both sides, up to a max. of 120 minutes.

Frame has to be filled with plasterboard, ceramic fibre blanket or grout to achieve 30 minute insulation rating.

WALL TYPE: **KOROK / SPEEDWALL**

FRAME TYPE: **STEEL, 1-PART**

Frame materials available:

- EGZ - 1.6 mm
- Cold rolled galvanized - 1.6 mm

Fasteners:

- Jamb fixing 6 sets (i.e. 12 per jamb)
- 10g x 75mm self tapping screws

Head Fixing (minimum):

- Single door - none required
- Paired door - 1 set

Wedging gap:

- 0 - 15 mm

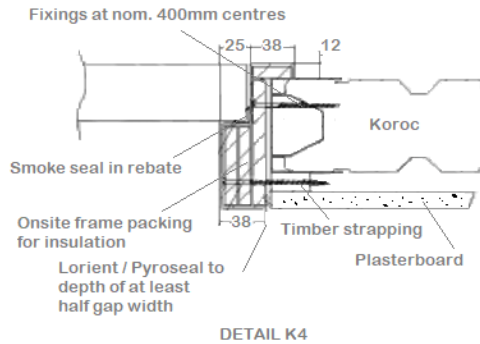

walls:

Fire rating for unlined Speedpanel / Korok

- 51 mm wall: Max. FRR -/60/30
- 64 mm wall: Max. FRR -/90/30
- 78 mm wall: Max. FRR -/120/30

Integrity rating can be increased by 30 minutes by lining the wall one or both sides, up to a max. of 120 minutes.

Frame has to be filled with plasterboard, ceramic fibre blanket or grout to achieve 30 minute insulation rating.

WALL TYPE: **KOROK / SPEEDWALL**

FRAME TYPE: **STEEL, 1-PART**

Frame materials available:

- EGZ - 1.6 mm
- Cold rolled galvanized - 1.6 mm

Fasteners:

- Jamb fixing 6 sets (i.e. 12 per jamb)
- 10g x 75mm self tapping screws

Head Fixing (minimum):

- Single door - none required
- Paired door - 1 set

Wedging gap:

- 0 - 15 mm

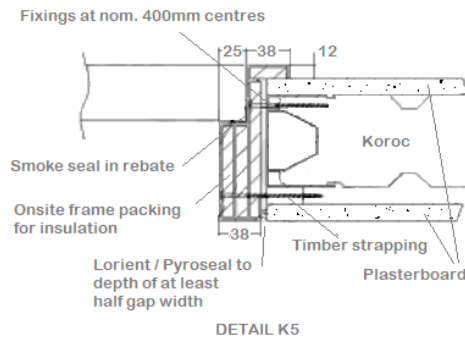

walls:

Fire rating for unlined Speedpanel / Korok

- 51 mm wall: Max. FRR -/60/30
- 64 mm wall: Max. FRR -/90/30
- 78 mm wall: Max. FRR -/120/30

Integrity rating can be increased by 30 minutes by lining the wall one or both sides, up to a max. of 120 minutes.

Frame has to be filled with plasterboard, ceramic fibre blanket or grout to achieve 30 minute insulation rating.

WALL TYPE: **KOROK / SPEEDWALL**

FRAME TYPE: **STEEL, 1-PART**

Frame materials available:

- EG Z - 1.6 mm
- Cold rolled galvanized - 1.6 mm

Fasteners:

- Jam b fixing 6 sets (i.e. 12 per jam b)
- 10g x 75mm self tapping screws

Head Fixing (minimum):

- Single door - none required
- Paired door - 1 set

Wedging gap:

- 0 - 15 mm

Fire rating for unlined Speedpanel / Korok

- 51 mm wall: Max. FRR -/60/30
- 64 mm wall: Max. FRR -/90/30
- 78 mm wall: Max. FRR -/120/30

Integrity rating can be increased by 30 minutes by lining the wall one or both sides, up to a max. of 120 minutes.

Frame has to be filled with plasterboard, ceramic fibre blanket or grout to achieve 30 minute insulation rating.

WALL TYPE: **KOROK / SPEEDWALL**

FRAME TYPE: **STEEL, 1-PART**

Frame materials available:

- EG Z - 1.6 mm
- Cold rolled galvanized - 1.6 mm

Fasteners:

- Jam b fixing 6 sets (i.e. 12 per jam b)
- 10g x 75mm self tapping screws

Head Fixing (minimum):

- Single door - none required
- Paired door - 1 set

Wedging gap:

- 0 - 15 mm

Fire rating for unlined Speedpanel / Korok

- 51 mm wall: Max. FRR -/60/30
- 64 mm wall: Max. FRR -/90/30
- 78 mm wall: Max. FRR -/120/30

Integrity rating can be increased by 30 minutes by lining the wall one or both sides, up to a max. of 120 minutes.

Frame has to be filled with plasterboard, ceramic fibre blanket or grout to achieve 30 minute insulation rating.

WALL TYPE: **KOROK / SPEEDWALL**

FRAME TYPE: **STEEL, 1-PART**

Frame materials available:

- EG Z - 1.6 mm
- Cold rolled galvanized - 1.6 mm

Fasteners:

- Jam b fixing 6 sets (i.e. 12 per jam b)
- 10g x 75mm self tapping screws

Head Fixing (minimum):

- Single door - none required
- Paired door - 1 set

Wedging gap:

- 0 - 15 mm

Fire rating for unlined Speedpanel / Korok

- 51 mm wall: Max. FRR -/60/30
- 64 mm wall: Max. FRR -/90/30
- 78 mm wall: Max. FRR -/120/30

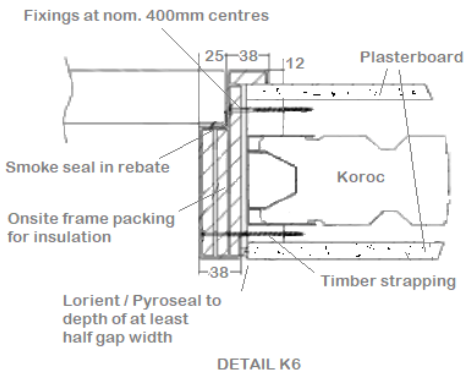

DETAIL K6

walls:

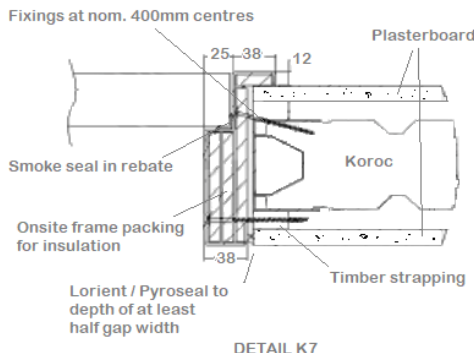

DETAIL K7

walls:

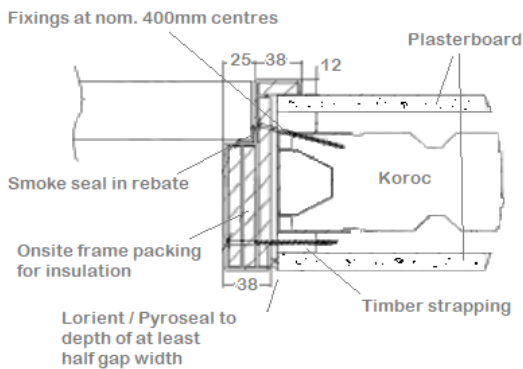

DETAIL K8

walls:

Integrity rating can be increased by 30 minutes by lining the wall one or both sides, up to a max. of 120 minutes.

Frame has to be filled with plasterboard, ceramic fibre blanket or grout to achieve 30 minute insulation rating.

WALL TYPE: **KOROK / SPEEDWALL**

FRAME TYPE: **STEEL, 1-PART**

Frame materials available:

- EGZ - 1.6 mm
- Cold rolled galvanized - 1.6 mm

Fasteners:

- Jamb fixing 6 sets (i.e. 12 per jamb)
- 10g x 75mm self tapping screws

Head Fixing (minimum):

- Single door - none required
- Paired door - 1 set

Wedging gap:

- 0 - 15 mm

Fire rating for unlined Speedpanel / Korok

- 51 mm wall: Max. FRR -/60/30
- 64 mm wall: Max. FRR -/90/30
- 78 mm wall: Max. FRR -/120/30

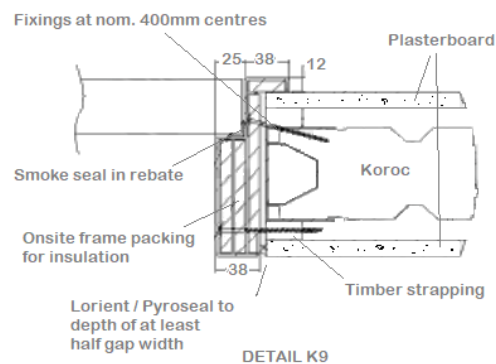

walls:

Integrity rating can be increased by 30 minutes by lining the wall one or both sides, up to a max. of 120 minutes.

Frame has to be filled with plasterboard, ceramic fibre blanket or grout to achieve 30 minute insulation rating.

WALL TYPE: **KOROK / SPEEDWALL**

FRAME TYPE: **STEEL, 1-PART**

Frame materials available:

- EGZ - 1.6 mm
- Cold rolled galvanized - 1.6 mm

Fasteners:

- Jamb fixing 6 sets (i.e. 12 per jamb)
- 10g x 75mm self tapping screws

Head Fixing (minimum):

- Single door - none required
- Paired door - 1 set

Wedging gap:

- 0 - 15 mm

Fire rating for unlined Speedpanel / Korok

- 51 mm wall: Max. FRR -/60/30
- 64 mm wall: Max. FRR -/90/30
- 78 mm wall: Max. FRR -/120/30

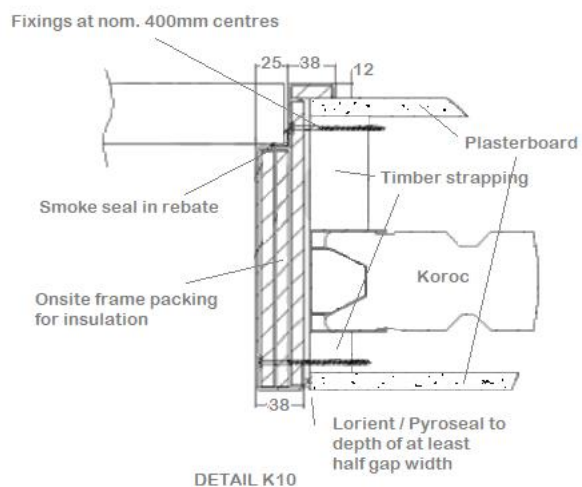

walls:

Integrity rating can be increased by 30 minutes by lining the wall one or both sides, up to a max. of 120 minutes.

Frame has to be filled with plasterboard, ceramic fibre blanket or grout to achieve 30 minute insulation rating.

WALL TYPE: **KOROK / SPEEDWALL**

FRAME TYPE: **STEEL, 1-PART**

Note: This installation method is only applicable to 78 mm Korok walls

Frame materials available:

- EGZ - 1.6 mm
- Cold rolled galvanized - 1.6 mm

Fasteners:

- Jamb fixing 6 sets (i.e. 12 per jamb)
- 10 x 75 mm Gauge self tapping screws

Head Fixing (minimum):

- Single door - none required
- Paired door - 1 set

Wedging gap:

- 0 - 15 mm

Fire rating for unlined Speedpanel / Korok

- 78 mm wall: Max. FRR -/120/30

Frame has to be filled with plasterboard, ceramic fibre blanket or grout to achieve 30 minute insulation rating.

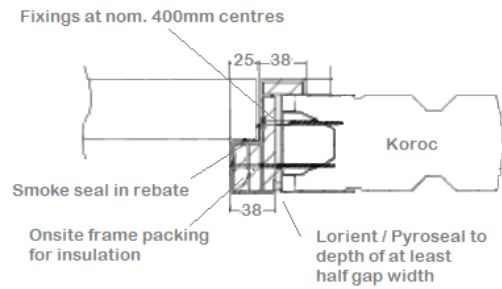

DETAIL K11

walls:

WALL TYPE: **TIMBER STUD**

FRAME TYPE: **STEEL, 1-PART**

Frame materials available:

- EGZ - 1.6 mm
- Cold rolled galvanized - 1.6 mm

Fasteners:

- Folded steel connection plates (as shown) to be supplied with frames.
- Hook onto frame bracing straps and nail or screw to timber studs.
- Frame connection plates either clouts (30 x 2.5 mm gib clouts) or screw fixed.

Head Fixing (minimum):

- Single door - none required
- Paired door - single central fastener required

Stud size:

- Ex 100 x 50 minimum

Wedging gap:

- Not applicable

Insulation rating:

To obtain an insulation rating, the steel frame must be packed with either;

- Plasterboard (30 minutes)
- Ceramic fibre blanket (30 minutes)
- Cornice plaster (30 minutes)
- Grout (60 minutes)
- Pyropanel M4 mortar (60 minutes)

No frame packing equals no insulation rating (i.e. -/xx/-)

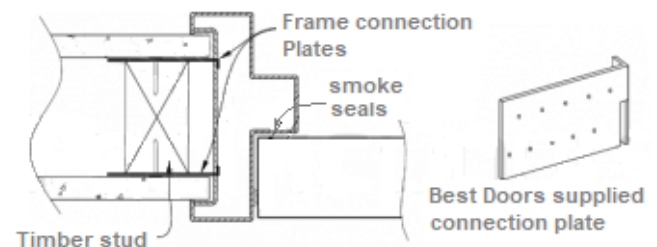

FRAME PROFILE D3

Same method for G & J: wall thickness will determine profiles available

WALL TYPE: **TIMBER STUD**

FRAME TYPE: **STEEL, 1-PART**

Frame materials available:

- EGZ - 1.6 mm
- Cold rolled galvanized - 1.6 mm

Fasteners:

- Framing stud No.1 screwed to jamb.
- Connection to stud No.2 via rebated nail on plates. One fastener per location except at bottom where two fasteners are required.
- Frame to be screw fixed (10g x 50mm self tapping) at 600mm nominal centres. Two fasteners per location where applicable.

Head Fixing (minimum):

- Single door - none required
- Paired door - single central fastener required

Stud size:

- Ex 100 x 50 minimum

Wedging gap:

- Not applicable

Insulation rating:

To obtain an insulation rating, the steel frame must be packed with either;

- Plasterboard (30 minutes)
- Ceramic fibre blanket (30 minutes)
- Cornice plaster (30 minutes)
- Grout (60 minutes)
- Pyropanel M4 mortar (60 minutes)

No frame packing equals no insulation rating (i.e. -/xx/-)

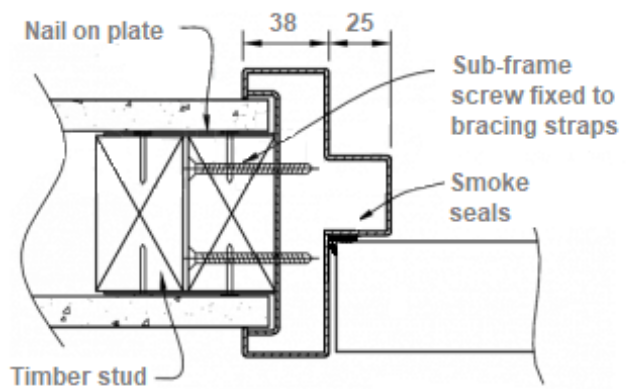

FRAME PROFILE D3

Same method for G & J: wall thickness will determine profiles available

WALL TYPE: **TIMBER STUD**

FRAME TYPE: **STEEL, 1-PART**

Frame materials available:

- EGZ - 1.6 mm
- Cold rolled galvanized - 1.6 mm

Fasteners:

- Frame screwed to stud through Gib Fyreline packing between stud and shims.
- Frame to be screw fixed (10g x 50mm tapping) at 600mm nominal centres. Two fasteners per location where applicable.

Head Fixing (minimum):

- Single door - none required
- Paired door - single central fastener required

Stud size:

- Ex 100 x 50 minimum

Wedging gap:

- 0-10 mm

Insulation rating:

To obtain an insulation rating, the steel frame must be packed with either;

- Plasterboard (30 minutes)
- Ceramic fibre blanket (30 minutes)
- Cornice plaster (30 minutes)
- Grout (60 minutes)
- Pyropanel M4 mortar (60 minutes)

No frame packing equals no insulation rating (i.e. -/xx/-)

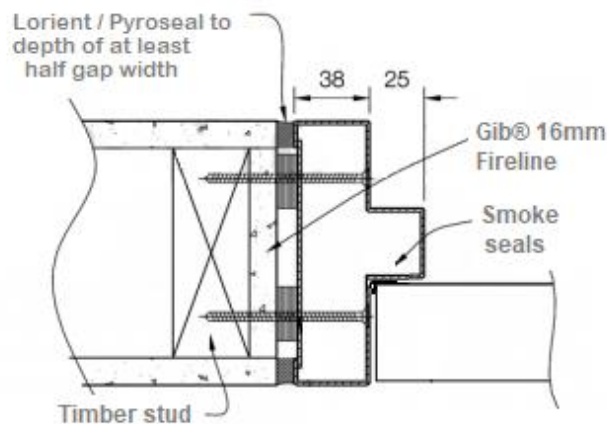

FRAME PROFILE D3

Same method for G & J: wall thickness will determine profiles available

self

WALL TYPE: **TIMBER STUD**

FRAME TYPE: **STEEL, 1-PART**

Frame materials available:

- EG Z - 1.6 mm
- Cold rolled galvanized - 1.6 mm

Fasteners :

- Frames may be screwed directly to studs either through the stud and into the frame bracing straps or through the frame into the timber stud at 600 mm centres minimum.
- Frame to be screw fixed (10g x 50mm self tapping) at 600 mm nominal centres. Two fasteners per location where applicable.

Head Fixing (minimum) :

- Single door - none required
- Paired door - single central fastener required

Stud size :

- Ex 100 x 50 minimum

Wedging gap :

- Not applicable

Insulation rating :

To obtain an insulation rating, the steel frame must be packed with either;

- Plasterboard (30 minutes)
- Ceramic fibre blanket (30 minutes)
- Cornice plaster (30 minutes)
- Grout (60 minutes)
- Pyropanel M4 mortar (60 minutes)

No frame packing equals no insulation rating (i.e. -/xx/-)

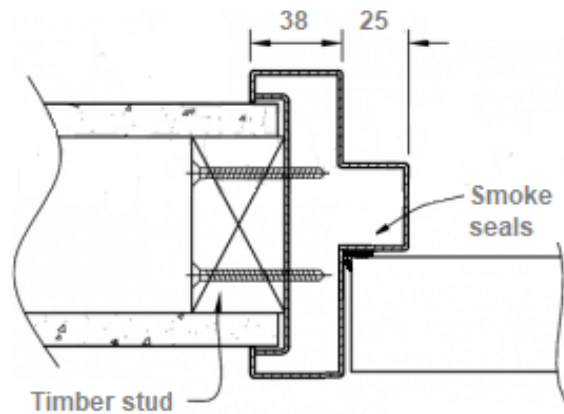

FRAME PROFILE D3

Same method for G & J : wall thickness will determine profiles available

WALL TYPE: **TIMBER STUD**

FRAME TYPE: **STEEL, 1-PART**

Frame materials available :

- EG Z - 1.6 mm
- Cold rolled galvanized - 1.6 mm

Fasteners :

- Frame screwed to stud through Gib Fyreline packing between stud and shims.
- Frame to be screw fixed (10g self tapping) at 600 mm nominal centres. Two fasteners per location where applicable.

Head Fixing (minimum) :

- Single door - none required
- Paired door - single central fastener required

Stud size :

- Ex 100 x 50 minimum

Wedging gap :

- 0-10 mm

Insulation rating :

To obtain an insulation rating, the steel frame must be packed with either;

- Plasterboard (30 minutes)
- Ceramic fibre blanket (30 minutes)
- Cornice plaster (30 minutes)
- Grout (60 minutes)
- Pyropanel M4 mortar (60 minutes)

No frame packing equals no insulation rating (i.e. -/xx/-)

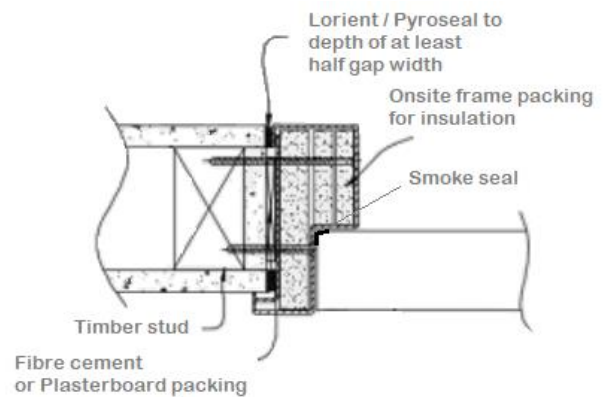

FRAME PROFILE R

WALL TYPE: **TIMBER STUD**

FRAME TYPE: **STEEL, 1-PART**

Frame materials available:

- EG Z - 1.6 mm
- Cold rolled galvanized - 1.6 mm

Fasteners:

- Frame screwed to stud through frame wings
- Frame to be screw fixed (10 g x 50 mm self tapping) at 600 mm nominal centres

Head Fixing (minimum):

- Single door - none required
- Paired door - single central fastener required

Stud size:

- Ex. 100x50 mm minimum

Wedging gap:

- 0-10 mm

Insulation rating:

To obtain an insulation rating, the steel frame must be packed either;

- Plasterboard (30 minutes)
- Ceramic fibre blanket (30 minutes)
- Cornice plaster (30 minutes)
- Grout (60 minutes)
- Pyropanel M4 mortar (60 minutes)

No frame packing equals no insulation rating (i.e. -/xx/-)

WALL TYPE: **MASONRY**

FRAME TYPE: **STEEL, 1-PART**

Frame materials available:

- EG Z - 1.6 mm
- Cold rolled galvanized - 1.6 mm
- Stainless Steel - 1.5 mm (Must be fully grouted frame VP 90-120)

Fasteners:

- Jamb fixing at 600mm centres minimum
- Expansion anchors eg. M10 countersunk 'Ramset' Dynabolts
- M12 countersunk masonry screwbolts

Head Fixing (minimum):

- Single door - none required
- Paired door - single central fastener required

Wedging Gap:

- 0-15 mm

Insulation rating:

To obtain an insulation rating, the steel frame must be packed with either;

- Plasterboard (30 minutes)
- Ceramic fibre blanket (30 minutes)
- Cornice plaster (30 minutes)
- Grout (60 minutes)
- Pyropanel M4 mortar (60 minutes)

No frame packing equals no insulation rating (i.e. -/xx/-)

WALL TYPE: **STEEL STUD**

FRAME TYPE: **STEEL, 1-PART**

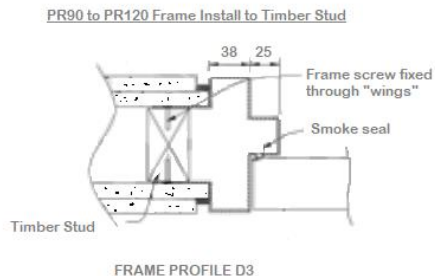

with

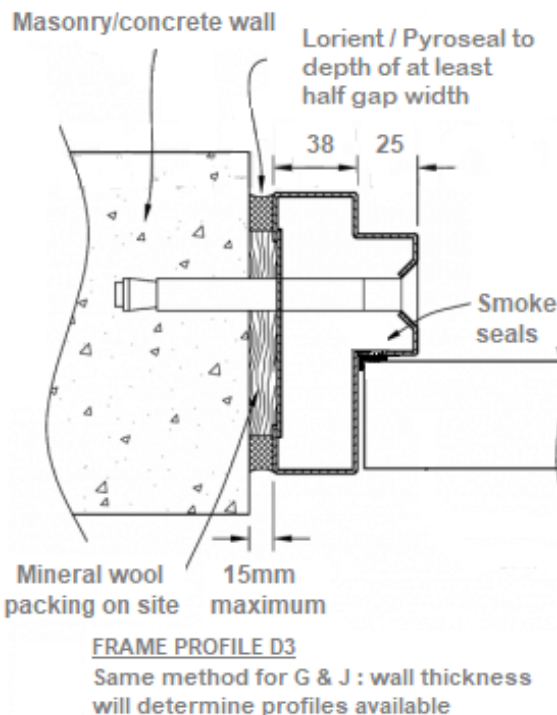

Frame materials available:

- EG Z - 1.6 mm
- Cold rolled galvanized - 1.6 mm

Fasteners:

- Boxed stud riveted with steel pop rivets or screwed with self tapping screws to frame bracing straps at 600 mm centres minimum.
- Steel studs may be riveted (steel pop rivets) or screwed (9g x 45 mm self tapping) to the frame bracing straps.

Head Fixing (minimum):

- Single door - none required
- Paired door - single central fastener required

Stud size:

- 65 x 34 mm minimum of 0.55 SM G gauge

Wedging gap:

- Not applicable

Insulation rating:

To obtain an insulation rating, the steel frame must be packed with either;

- Plasterboard (30 minutes)
- Ceramic fibre blanket (30 minutes)
- Cornice plaster (30 minutes)
- Grout (60 minutes)
- Pyropanel M4 mortar (60 minutes)

No frame packing equals no insulation rating (i.e. -/xx/-)

WALL TYPE: **STEEL STUD**

FRAME TYPE: **STEEL, 1-PART**

Frame materials available:

- EG Z - 1.6 mm
- Cold rolled galvanized - 1.6 mm

Fasteners:

- Frame screwed to boxed stud at 600 mm centres minimum with self tapping screws.
- Steel studs may be riveted (steel pop rivets) or screwed (9g x 45 mm self tapping) to the frame bracing straps.

Head Fixing (minimum):

- Single door - none required
- Paired door - single central fastener required

Stud size:

- 65 x 34 mm minimum of 0.55 SM G gauge

Wedging gap:

- Not applicable

Insulation rating:

To obtain an insulation rating, the steel frame must be packed with either;

- Plasterboard (30 minutes)
- Ceramic fibre blanket (30 minutes)
- Cornice plaster (30 minutes)
- Grout (60 minutes)
- Pyropanel M4 mortar (60 minutes)

No frame packing equals no insulation rating (i.e. -/xx/-)

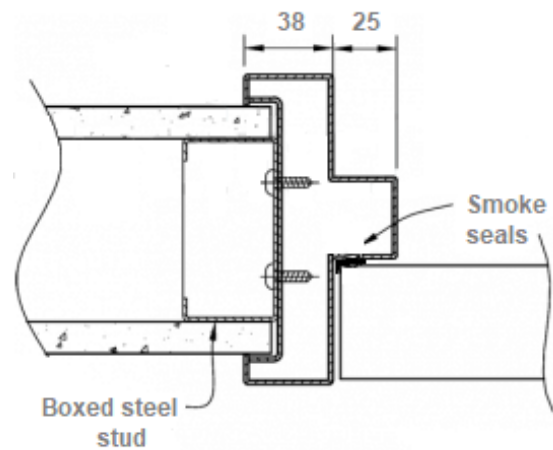

FRAME PROFILE D3

same method for G & J : wall thickness will determine profiles available

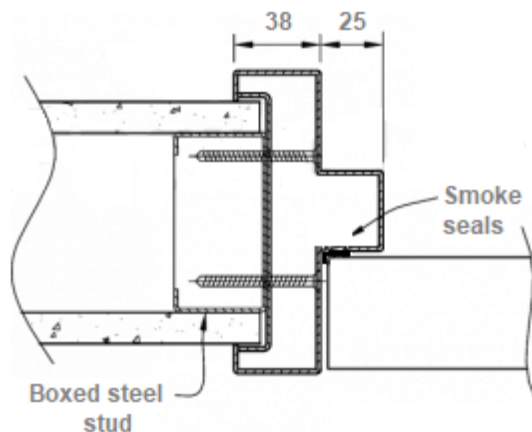

FRAME PROFILE D3

same method for G & J : wall thickness will determine profiles available

WALL TYPE: **STEEL STUD**

FRAME TYPE: **STEEL, 1-PART**

Frame materials available:

- EG Z - 1.6 mm
- Cold rolled galvanized - 1.6 mm

Fasteners:

- Frame screwed to boxed studs with packing steel shims.
- Steel studs may be riveted (steel pop rivets) or screwed (9g x 45mm self tapping) to the frame bracing straps.

Head Fixing (minimum):

- Single door - none required
- Paired door - single central fastener required

Stud size:

- 65 x 34 mm minimum of 0.55 SM G gauge

Wedging Gap:

- 0-10 mm

Insulation rating:

To obtain an insulation rating, the steel frame must be packed with either;

- Plasterboard (30 minutes)
- Ceramic fibre blanket (30 minutes)
- Cornice plaster (30 minutes)
- Grout (60 minutes)
- Pyropanel M4 mortar (60 minutes)

No frame packing equals no insulation rating (i.e. -/xx/-)

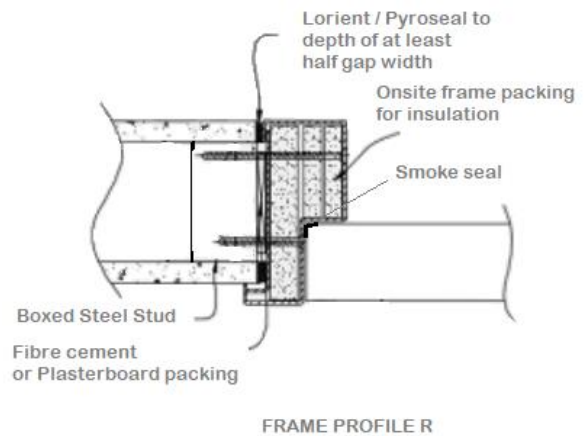

same method for G & J: wall thickness will determine profiles available

WALL TYPE: **STEEL STUD**

FRAME TYPE: **STEEL, 1-PART**

Frame materials available:

- EG Z - 1.6 mm
- Cold rolled galvanized - 1.6 mm

Fasteners:

- Frame screwed to stud through Gib Fyreline packing between stud and shims.
- Frame to be screw fixed (10g x 50mm self tapping) at 600 mm nominal centres. Two fasteners per location where applicable.

Head Fixing (minimum):

- Single door - none required
- Paired door - single central fastener required

Stud size:

- 92 x 34 mm minimum of 0.55 SM G gauge

Wedging gap:

- 0-10 mm

Insulation rating:

To obtain an insulation rating, the steel frame must be packed with either;

- Plasterboard (30 minutes)
- Ceramic fibre blanket (30 minutes)
- Cornice plaster (30 minutes)
- Grout (60 minutes)
- Pyropanel M4 mortar (60 minutes)

No frame packing equals no insulation rating (i.e. -/xx/-)

WALL TYPE: **STEEL STUD**

FRAME TYPE: **STEEL, 1-PART**

Frame materials available:

- EG Z - 1.6 m m
- Cold rolled galvanized - 1.6 m m

Fasteners :

- Frame screwed to stud through frame wings
- Frame to be screw fixed (10 g x 50 m m self tapping) at 600 m m nominal centres

Head Fixing (minimum) :

- Single door - none required
- Paired door - single central fastener required

Stud size :

- 65 x 34 m m minimum of 0.55 MSG gauge.

Wedging gap :

- 0-10 m m

Insulation rating :

To obtain an insulation rating, the steel frame must be packed with either;

- Plasterboard (30 minutes)
- Ceramic fibre blanket (30 minutes)
- Cornice plaster (30 minutes)
- Grout (60 minutes)
- Pyropanel M4 mortar (60 minutes)

No frame packing equals no insulation rating (i.e. -/xx/-)

