



RT25/50

Regular Traffic

- 12V/24V
- 25/50m per min
- 500/300kg

HT18/36

High Traffic

- 12V/24V
- 18/36m per min
- 600/300kg



Proudly manufactured by



www.dace.co.za

INSTALLATION & USER MANUAL

1.0	Foreword	3
2.0	Abbreviations	3
3.0	Introduction & Recommendations	4
4.0	Specifications	
4.1	Ultima Operator	5
4.2	Tritek Controller	6
5.0	Operator & Site Basics	
5.1	Operator Parts Identification	7
5.2	Site Layout	8
5.3	Gate Pull & Running Forces	8
5.4	Cable Recommendations	10
6.0	Installing the Operator	
6.1	Anchoring the Foundation Plate	11
6.2	Removing the Lid	11
6.3	Placing the Operator in Manual Override	11
6.4	Securing Operator to the Foundation Plate	12
6.5	Mounting the Rack on the Gate	12
6.6	Placing Oil in the Gearbox	14
6.7	Mounting the Marker Magnet	14
7.0	Controller Basics	
7.1	Tritek Control Board Layout	15
7.2	Overview of Power Connections & Fuses	15
7.3	Overview of Low Power Inputs & Outputs	16
8.0	Charging Supply Options	17
9.0	Menu Navigation Overview	18
10.0	Commissioning the Operator for the first time	19
11.0	Wiring Diagrams	
11.1	Two Sets of Safety Beams (Relay Output)	20
11.2	External Radio Receiver & Loop Detector	21
11.3	Closing Safety Beam (FET Output & Relay Output)	22
11.4	Opening Safety Beam (FET Output & Relay Output)	23
11.5	Connecting Common External Devices	24
11.6	Connection for Relay Module	25
11.7	Electric & Magnetic Locks	26
11.8	Connecting Various Devices to Pulse & Alarm Outputs	27
11.9	Two Synchronised Operators connected to One Set of Safety Beams	28
12.0	Control Board Functions	
12.1	Beam Settings	29
12.2	Auto Close Setup	30
12.3	Remote Settings	30
12.4	Pedestrian Entry	32
12.5	Light Settings	33
12.6	Security Settings	33
12.7	Lock Settings	34
12.8	Operating Modes	35
12.9	GSM Settings	35
12.10	Energy Saving	35
12.11	USB Settings	36
12.12	HID Settings	37
12.13	Diagnostics	37
12.14	General Settings	37
12.15	Time Manager	37
12.16	Gate Setup	39
13.0	Additional Features	
13.1	Holiday Lockout	41
13.2	Ground Loop	41
14.0	Upgrading Controller Software	42
15.0	Service Schedule	42
16.0	Notification Messages	43
17.0	Warning Messages	44
18.0	Glossary	46
19.0	Technical Specifications	48
20.0	Terms & Conditions	49
21.0	Warranty & Disclaimer	52

Thank you for choosing Dura Access Control Equipment (DACE). We welcome you to the ever growing community of happy DACE product owners. The advanced engineering and high-quality construction of each DACE product we build is something of which we are proud.

The Ultima gate operator is packed with features to bring you more convenience and to enhance your security.

Your owners manual will introduce you to the features and operation of your new Ultima gate operator. It is suggested that you read it carefully since the information it contains can contribute greatly to the satisfaction you receive from your new gate operator.

We also recommend that you follow the maintenance schedule so that your operator will give you many years of problem free service.

Please keep this manual in a safe, convenient place so that you can refer to it from time to time when performing maintenance or activating new features.

Look out for these icons in the instruction manual:



Take Careful Note! Information that may affect the operator or function in a way you did not expect. .



Good Idea! Following this instruction might assist in the future or help with the installation.



Warning! Information about potential hazard/s & detail requiring your special attention.

Please attach your invoice to this manual for future use (see warranty).

Please read the maintenance schedule for your Ultima operator to ensure its longevity and continuous safe operation.

ABBREVIATIONS

AC	Alternating Current (pertaining to a supply voltage)
AC	Auto Close (pertaining to the gate moving)
BAC	Beams Auto Close (Same as PIRAC)
DACE	Dura Access Control Equipment
DC	Direct Current
DIY	Do It Yourself
E.C.A	Electrical Contractors Association
FRX	Free Exit
HID	Human Interface Device (Joystick / Speaker / Display)
IR	Infrared
IRBC	Closing Infrared Beam (Safety Beam)
IRBO	Opening Infrared Beam (Safety Beam)
LCD	Liquid Crystal Display
LED	Light Emitting Diode (Indicator light)
Mag	Magnetic
NAV	Navigation
PED	Pedestrian
PIRAC	Passive Infrared Auto Close (Same as BAC)
RSSI	Receiver Signal Strength Indicator
RX	Receiver (or onboard receiver)
Trig	Trigger
TX	Transmitter

INTRODUCTION & RECOMMENDATIONS

DACE is a proven leader in the manufacturing of automatic gate & garage operators and strives to manufacture high quality products using the latest technology. We are constantly working on upgrading our products to bring you, our clients, products of the finest quality.



We strongly recommended using the services of an experienced gate installer to install your gate operator but if you intend installing the operator yourself, the manual must be read carefully before any installation begins.

While we have taken all reasonable steps to ensure that your gate operator is safe to install and use, it must be noted that your gate is a heavy moving piece of equipment and can cause serious damage or injury if it strikes an object or person. Your gate operator has built in electronic collision sensing which will make the gate stop and reopen if it strikes an object. This does mean however, that the gate will actually strike the object before it stops. It is because of this that we strongly recommended that DuraOptics Safety Beams are installed to reduce the risk of the gate striking an object.



The installation of beams does not guarantee that the moving gate will not strike an object in it's path.

Check the following items before installing the operator:

- ◆ That the rail is level – the gate must not move on its own at any stage (discuss options available to you with your supplier if the rail is not level).
- ◆ That the wheels are turning freely and are not jammed.
- ◆ That the gate is not bent or bowed in any way.
- ◆ That the rail has sufficient end stops so that the gate can never run off the end of the rail.
- ◆ That the portal is constructed in such a way that the gate can not fall over.
- ◆ That the top rollers are turning freely and are not jammed.
- ◆ That the anti lift device is sufficient in order to stop the gate from being lifted off the rail.
- ◆ That the gate mass or start-up force does not exceed the maximum as stated in the specifications.
- ◆ That the gate does not jam in the catch bracket when closing or opening.
- ◆ The gate must not exceed the maximum number of operations stated in the specifications.
- ◆ Extreme care should be taken when automating a gate that is fully cladded, as wind resistance can cause the gate to not close properly.

Only when all the above points are satisfactory should you go ahead with installing the gate operator. If a gate causes damage or injury the installer of the equipment may be held liable.

DO NOT CONNECT MAINS VOLTAGE DIRECTLY TO THE CONTROLLER



If you intend to run AC directly from the building mains supply to the transformer, the wiring should be done by a qualified/registered electrician. This is a legal requirement and failure to do so may lead to non-compliance of property or law suits against the property owner in the event of an accident.

- ◆ When running mains supply to the gate, it is recommended that you contact your local E.C.A. (Electrical Contractors Association) in order to obtain the legal wiring regulations relevant to the region in which you live.
- ◆ Electrical shock can occur while installing this equipment
- ◆ Injury or death by electrocution may lead to law suits against the installer/homeowner.
- ◆ All wiring must be run in conduit. The supply wires must be run separate to any other wiring.
- ◆ Underground mains supply must be run in armoured cable.
- ◆ Under no circumstances may Communication cable, Ripcord or Cabytre be used for 220V/240V mains connections.
- ◆ Ensure that all electrical power is switched off before any electrical connections are made.
- ◆ Do not open, tamper or modify any of the electronic components of this equipment in any way.
- ◆ Do not attempt to repair the equipment, this should only be done by a qualified DACE technician.
- ◆ DACE will not be held liable for any accident / incident resulting in damage, injury or death ensuing from the incorrect installation of the automatic gate operator.
- ◆ Although these operators have built-in collision sensing, substantial damage can still occur. For this reason DuraOptics Safety Beams should be used on all installations.
- ◆ For safety reasons, the Ultima RT 25/50 will only close at the maximum speed of 50 meters per minute if there are safety beams connected to the operator.
- ◆ Do not allow children to play near or with any gate, gate operator or remote control.
- ◆ It is the responsibility of the installer to ensure that the gate is in good working condition before automating the gate.

Continues.....

.....continued

- ◆ DACE cannot be held responsible for a gate bumping either of the ends stops if it runs on a slope.
- ◆ Do not operate the gate unless within direct sight of the gate.
- ◆ A gate is a heavy piece of equipment and injury, even death, may occur due to incorrect installation or operation of the equipment. There are a number of areas that may cause entrapment which could lead to injury.

AREAS WHERE INJURY OR ENTRAPMENT CAN OCCUR

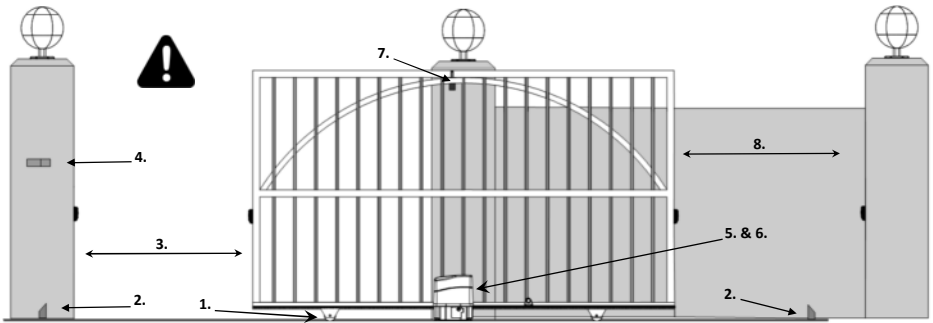

1. Gate Wheels (Pets at risk when lying at the gate)
2. Between the gate & the end stop
3. The gate, during the closing cycle
4. Between the gate & the catch bracket
5. Pinion Gear
6. Between the gate operator & the gate
7. Gate Rollers/Anti-lift device
8. The gate, during opening cycle

ULTIMA TECHNICAL SPECIFICATIONS

	RT25/50 <i>Regular Traffic</i>		HT18/36 <i>High Traffic</i>					
Battery Voltage	12V (7Ah)	24V (3.5 Ah)	12V (7Ah)	24V (3.5 Ah)				
Maximum Running Speed	25m/min	50m/min	18m/min	36m/min				
Gate Specifications								
Maximum Gate Mass	500kg	300kg	600kg	300kg				
Maximum Pull Force	22kgf / 220N	18kgf / 180N	28kgf / 280N	18kgf / 180N				
Maximum Running Force	15kgf / 150N	12kgf / 120N	18kgf / 180N	12kgf / 120N				
Maximum Gate Size <i>(Runtime Limited)</i>	20m	20m	20m	20m				
Motor Specifications								
Transformer Supply Voltage	220V / 240V AC	220V / 240V AC	220V / 240V AC	220V / 240V AC				
Maximum Supply Voltage	30V AC / 44V DC	30V AC / 44V DC	30V AC / 44V DC	30V AC / 44V DC				
Minimum Supply Voltage	16V AC / 17V DC	22V AC / 30V DC	16V AC / 17V DC	22V AC / 30V DC				
Solar Power Ready	YES	YES	YES	YES				
Maximum Current Draw	1.5A	1.5A	1.5A	1.5A				
Standby Power Consumption	0.1W	0.1W	0.1W	0.1W				
Maximum Standby Time	Up to 25 days	Up to 12 days	Up to 25 days	Up to 12 days				
Collision Sensing	Electronic	Electronic	Electronic	Electronic				
On Board Receiver	1024 Remotes	1024 Remotes	1024 Remotes	1024 Remotes				
Maximum number of openings for a 4m gate per day								
	Mains On	Mains Fail	Mains On	Mains Fail	Mains On	Mains Fail	Mains On	Mains Fail
Pull Force 15kgf	45	45 **	N/A	N/A	45	45 **	N/A	N/A
Pull Force 12kgf	65	65 **	65	35 **	65	65 **	65	35 **
Pull Force 7kgf	95	95 **	95	45 **	95	95 **	95	45 **
Pull Force 5kgf	130	130 **	130	65 **	150	150 **	150	75 **

** Within 24hrs

TRITEK CONTROLLER SPECIFICATIONS

Onboard Graphic Display	64 x 128 Graphics LCD
Dual Processor	≈ P1: ARM (72 MHz) 256K FLASH / 64K RAM 32 Bit ≈ P2: PIC (32MHz) 2kB 8Bit
Memory	2 MB
Drive	H-Bridge
User Interface Tool	5 Way D-Pad 'Joystick'
Battery	12V or 24V
Input Supply	12-24V AC / 17-40V DC
Maximum standby duration	25 days
Solar power input	<input checked="" type="checkbox"/>
Sleep modes	<ul style="list-style-type: none"> · Light · Medium · Deep · Solar
Audible warnings	Voice
Menu Navigation	Icons with quick navigation & audio (spoken)
Receiver	16 Channel
Users	16,384 Buttons - 1024 Users
In field upgradable	Via USB Flash Drive or Android Phone
Event Log	1024 Events On screen viewing & downloadable to Flash
Controller Settings & Users Backup	Via USB flash drive or Android phone
Controller Time Management Functions	120
Battery charger	1.5A Intelligent multi stage charging with auto 12V/24V charge selection
Obstacle sensing	Electronic
Electric & Magnetic Lock functions	<input checked="" type="checkbox"/>
Remote user groups	15
Security alarm features	Forced Entry Ambush Break In Gate Stand Open Motor Tamper
Self diagnostics screen	<input checked="" type="checkbox"/>
Restore/undo functions	<input checked="" type="checkbox"/>
On board help screens	<input checked="" type="checkbox"/>
Outputs	5
Status	<input checked="" type="checkbox"/>
Alarm	<input checked="" type="checkbox"/>
Light	<input checked="" type="checkbox"/>
Pulse (Trigger)	<input checked="" type="checkbox"/>
Lock	<input checked="" type="checkbox"/> Relay

.....continued

Inputs	9
Trigger	<input checked="" type="checkbox"/>
Pedestrian	<input checked="" type="checkbox"/>
Free Exit/Loop	<input checked="" type="checkbox"/>
Controller Lock/Holiday Lock Out	<input checked="" type="checkbox"/>
Open Infrared	<input checked="" type="checkbox"/>
Close Infrared	<input checked="" type="checkbox"/>
Tamper	<input checked="" type="checkbox"/>
Light	<input checked="" type="checkbox"/>
GSM/WiFi	<input checked="" type="checkbox"/> DACE GSM/WiFi Module only

OPERATOR PARTS IDENTIFICATION

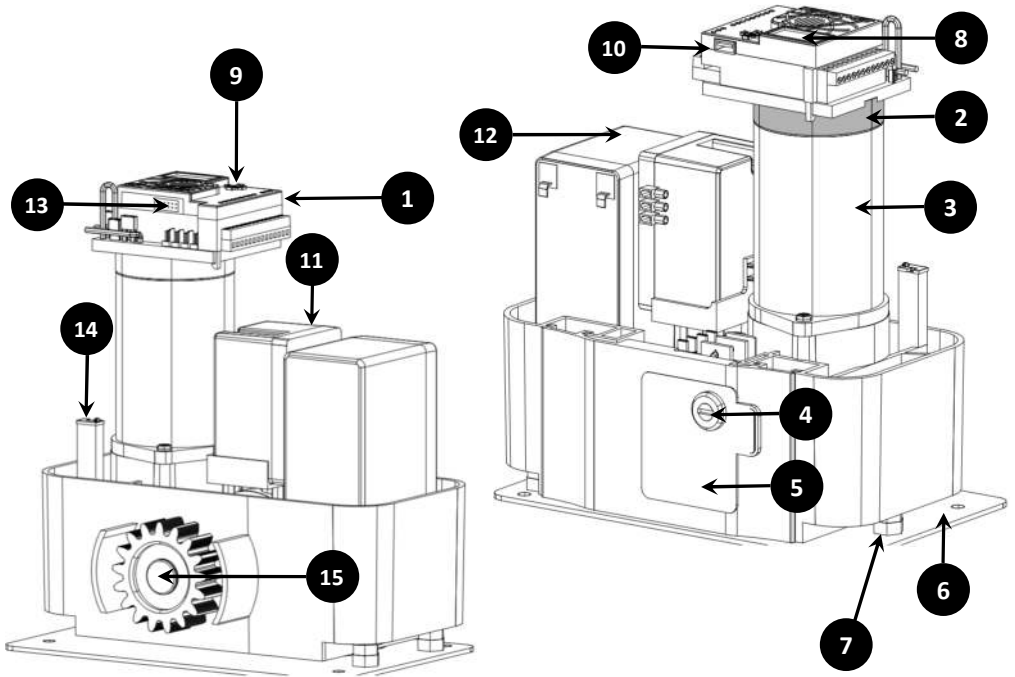

PARTS LIST

- | | | |
|------------------------|---------------------------|---------------------------|
| 1. Tritek Controller | 6. Foundation Plate | 11. Transformer |
| 2. Rev Counter Housing | 7. Height adjustment Nuts | 12. Battery |
| 3. 12 Volt DC Motor | 8. LCD Interface | 13. GSM/WiFi Module Input |
| 4. Cam Lock | 9. Joystick | 14. Marker Sensor |
| 5. Manual Release Door | 10. USB Input | 15. Pinion Gear |

SITE LAYOUT

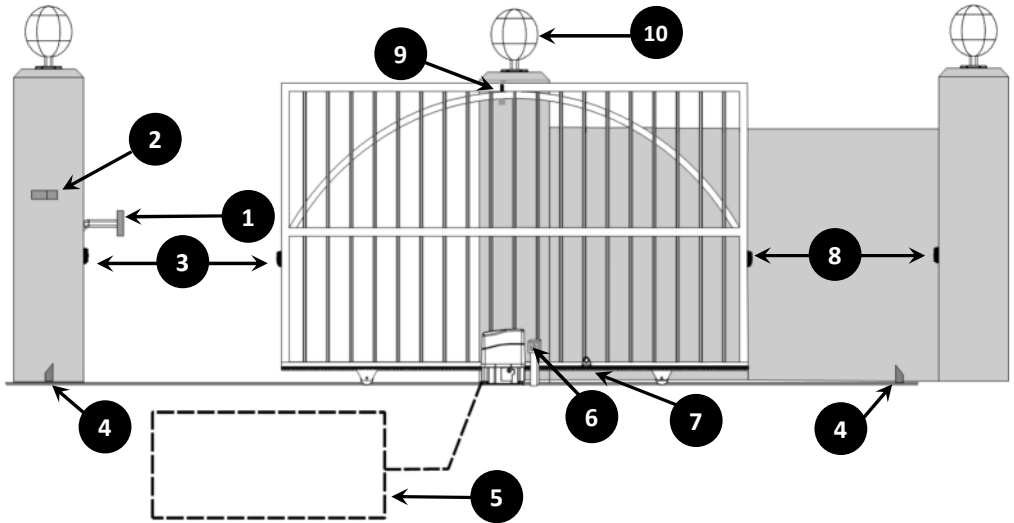

1. Intercom Gooseneck
2. Catch Bracket
3. Close Safety Beam
4. End Stop

5. Exit Loop
6. Isolator Switch
7. Marker Magnet
8. Open Safety Beam

9. Guide Rollers
10. Pillar Light

GATE PULL & RUNNING FORCES

The gate Pull and Running Forces must be measured before installing the operator. Should the measured forces exceed those in the table below, then the operator must not be installed. It may be possible to reduce these forces by carrying out maintenance on the gate & rail but if not, then the operator must not be installed.

These forces can be measured using a fishing or luggage scale (see figure alongside)

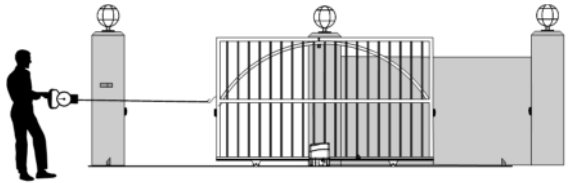

Pull Force: place the gate in the fully open/closed position and pull on the scale until the gate starts moving. The value showing on the scale at the point that the gate starts moving is the Pull Force kgf.

Running Force: this is the maximum value read while the gate is moving before coming to the fully open position.

	RT25/50 Regular Traffic		HT18/36 High Traffic	
	Maximum Gate Mass	500kg	300kg	600kg
Maximum Pull Force	22kgf / 220N	18kgf / 180N	28kgf / 280N	18kgf / 180N
Maximum Running Force	15kgf / 150N	12kgf / 120N	18kgf / 180N	12kgf / 120N

GATES ON A GRADIENT



We do not recommend automating a gate which is not level. Failure to level the gate will put undue stress on the operator. Furthermore, if the operator is in manual override mode, the gate may run freely down the slope and present a safety risk.

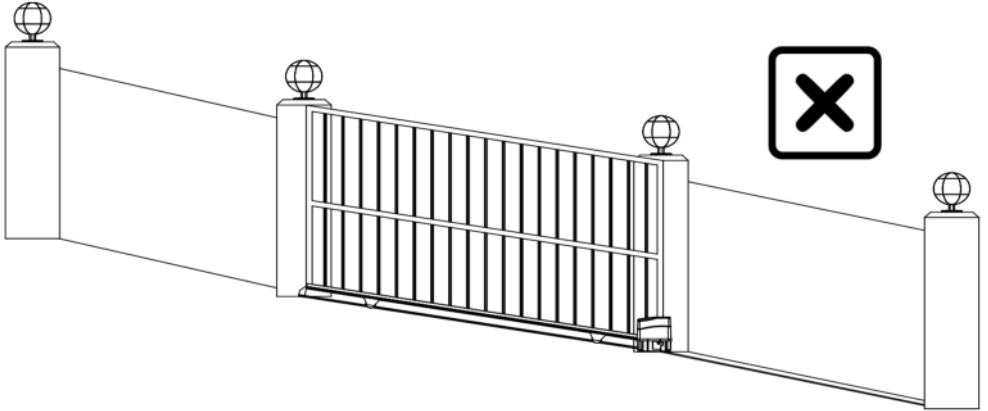

The gate should always be level. This can be achieved by leveling the track using supports or spacers.

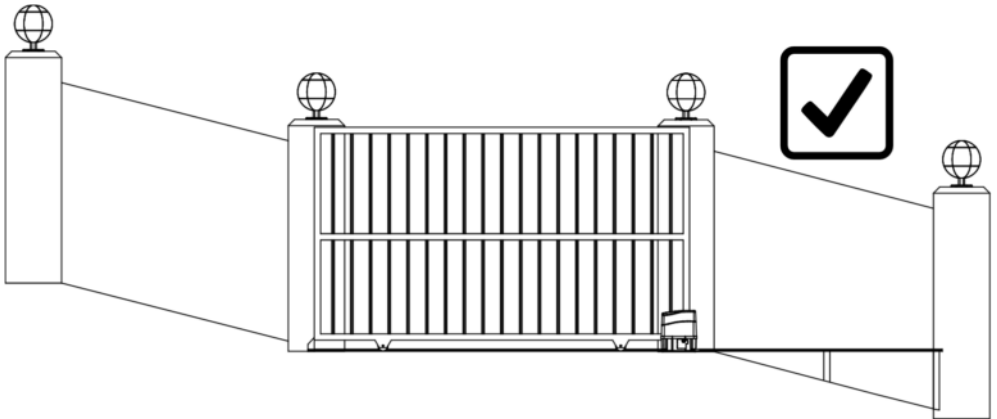

In circumstances where it is not possible to level the gate, it is necessary to check that the pull and running forces do not exceed the maximum values as per the table on page 8.

CABLE RECOMMENDATIONS

Two options for power supply:

1. Option 1 (Recommended):

Low voltage supply 14-24V AC via transformer placed in the house, max 50m from operator with 3 core 1.5mm² (Live, Neutral & Earth).

2. Option 2:

High voltage mains supply connected to a 220V/240V AC Double Pole Isolator switch, mounted within 1.5m of the operator connected to the transformer inside the operator. Isolator may not be obscured by the gate when in open position. Option 2 should be carried out by a qualified electrician.

3. Intercom gate station to operator (consult with Intercom supplier for cable requirements)

4. Keypad to operator (consult with keypad supplier for cable requirements)

5. CLOSING Infrared beams to operator. Highly recommended for safe operation (4 core 0.5mm² multi-stranded cable)

6. OPENING Infrared beams to operator. Highly recommended for safe operation (4 core 0.5mm² multi-stranded cable)

7. Exit Loop to operator (1 core- consult with loop detector supplier for cable requirements)

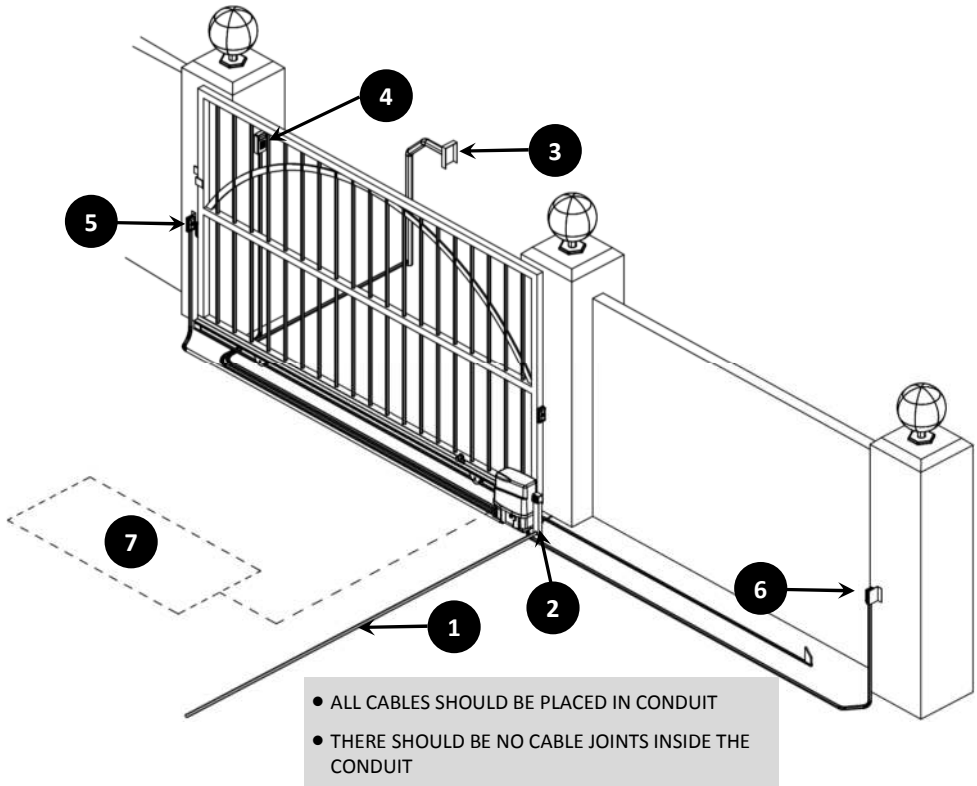

ANCHORING THE FOUNDATION PLATE

- I. Lay a concrete slab 400mm x 400mm x 200mm:
 - Dig a hole and place the conduit ① in the correct position.
 - Fill the hole with concrete & allow to set.
- II. Place the foundation plate on the concrete slab & feed the conduit through the cable inlets ②.
- III. Ensure a 23mm clearance between the inner edge of the foundation plate and the edge of the gate. This measurement is based on DACE rack. See below to calculate clearance if using other rack.
- IV. Attach the foundation plate to the slab using four 8mm anchors ③.

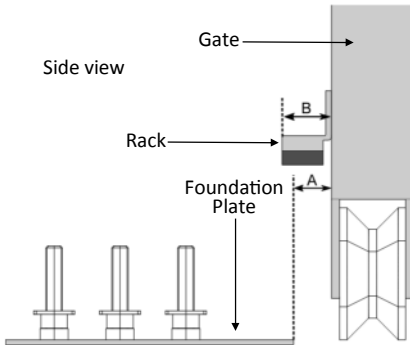
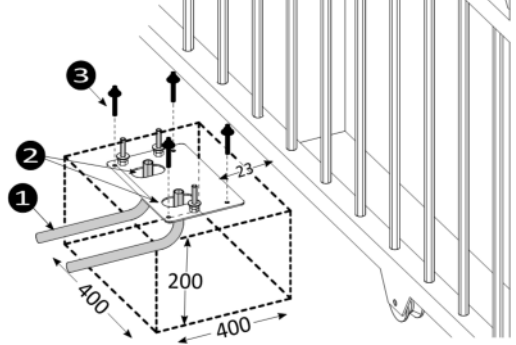

To calculate the clearance required between the edge of the foundation plate and the edge of the gate (A), measure the width of the rack (B) and minus 9.

eg. If the width of the rack is 32mm less 9 = 23. Thus the clearance required is 23mm

REMOVING THE LID

Open the 'manual release door' and pull the release pin until the lid is free. The Lid can now be removed.

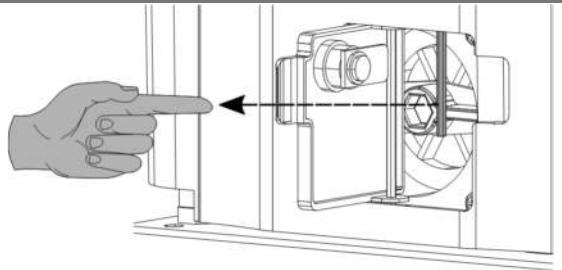

PLACING THE OPERATOR IN MANUAL OVERRIDE

1. Open the 'manual release door' and rotate the thumb wheel clockwise, just until the gate begins to move.
2. The thumb wheel must not be allowed to rotate too far.
3. To re-engage the gearbox, rotate the thumb wheel counter clockwise while pushing on the gate until you hear a click in the gearbox.
4. Do not rotate the thumb wheel any further after hearing the gearbox click.

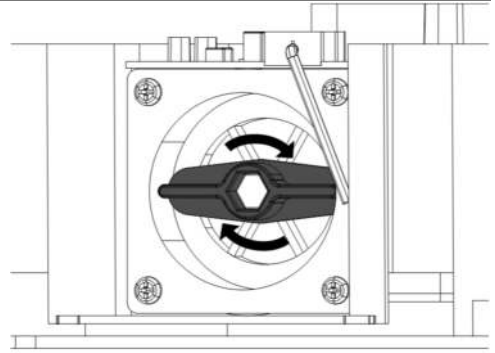

SECURE OPERATOR TO THE FOUNDATION PLATE

1. Raise the adjusting nuts ~ 5mm before mounting the operator to allow for fine height adjustment at a later time.
2. Mount the operator on the foundation plate.
3. Place a Spirit Level on top of the operator base while fastening the three securing nuts and washers ensuring that the operator is level.
4. Manually move the gate fully open and closed very slowly to ensure that the gate does not collide with the operator in any way.
5. Be sure to remove any cement/debris around the pinion gear.

 Mount the operator above the flood level or, if this is not possible, build a small protective wall structure in front of the operator to divert the water flow.

SIDE VIEW

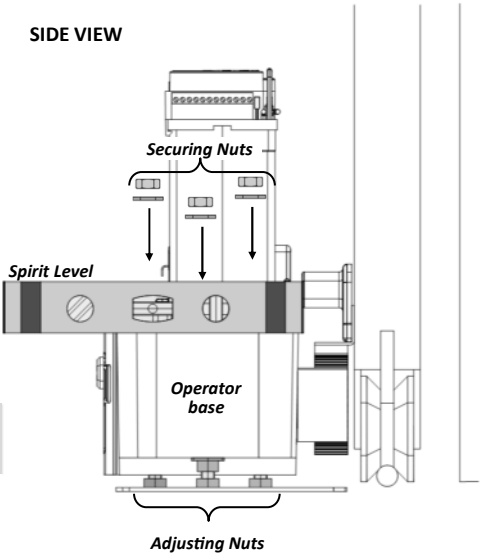

MOUNTING THE RACK ON THE GATE



Spacing between the Rack and the Pinion

DACE Grey Nylon Rack

This rack has a 2mm 'built in spacer' and therefore the mounted rack should rest on the pinion.

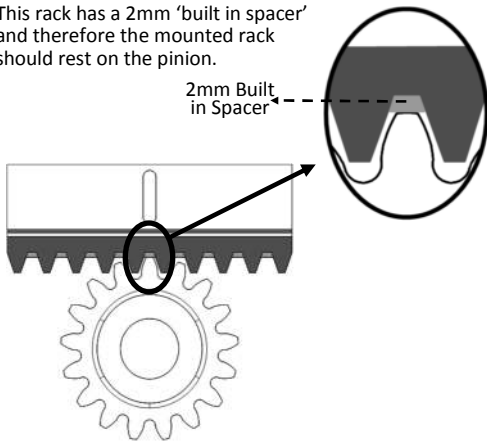

All Other Nylon Rack

There must be a 2mm clearance between the mounted rack and the pinion

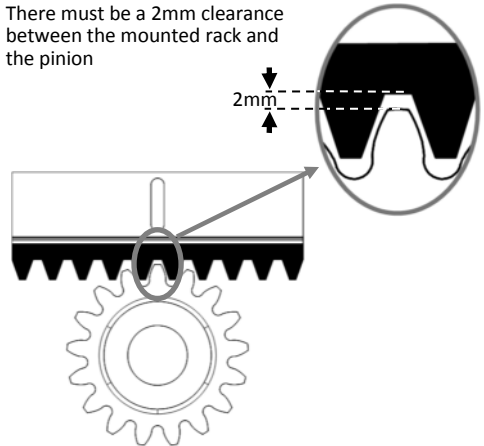

Continues.....

.....continued

1. Rest the rack on the pinion with the end of the rack and the end of the gate aligned. Having the gate slightly open will allow access to the first slot on the rack.
2. Clamp the opposite end of the rack to the gate.
3. Using a spirit level, ensure the rack is level.
4. Fasten the rack to the gate with the self drilling TEK screws through the slots in the rack.
5. To attach additional rack, slide the gate open and repeat the above procedures.
6. After the rack has been attached, use the Height Adjustment Nuts on the foundation plate for fine adjustment.

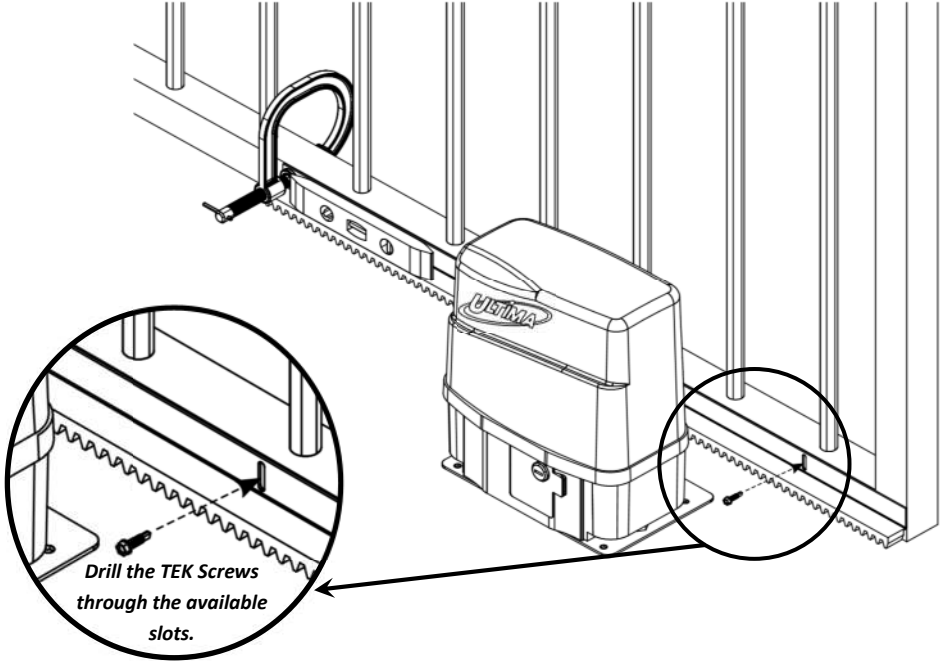

DO NOT automate a gate without end stops welded in position on both ends of the gate rail. These are used during the programming of the limits and are also required for safety reasons.

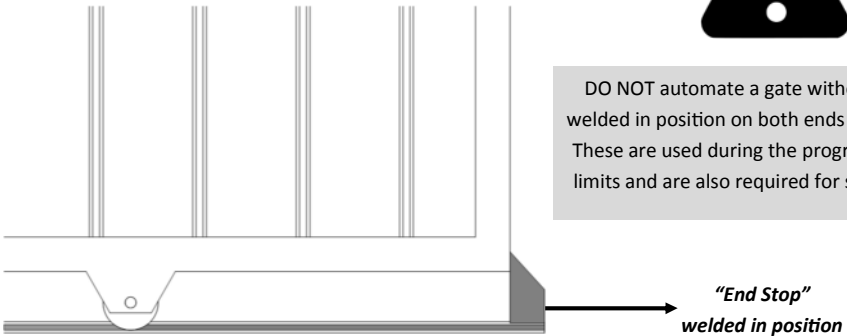

PLACING OIL IN THE GEARBOX



It is important that the gearbox be filled with oil before commissioning the operator.

Only use SAE75W-90 oil to refill.

Fill the gearbox with the oil provided as shown. The entire bottle (70ml) must be emptied into the gearbox.

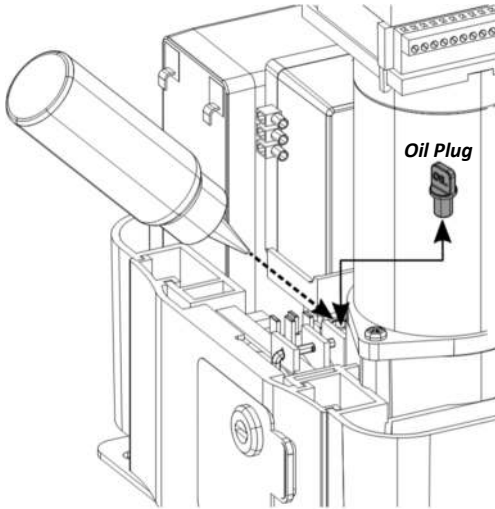

The gearbox oil will need to be topped up periodically. Before topping up, remove the 'Oil Level Screw' and pour in the oil until it just starts to run out the screw hole and then immediately replace the screw.

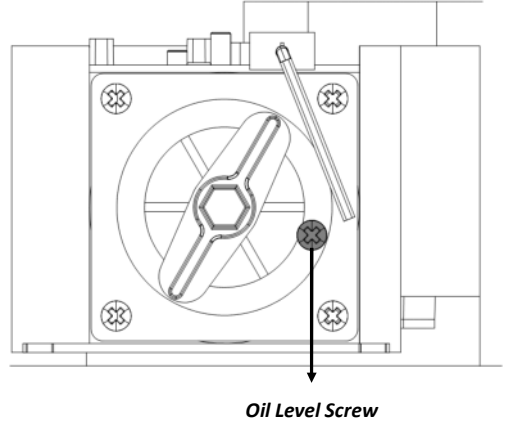

MOUNTING THE MARKER MAGNET

1. Push the gate to the fully closed position.
2. Place the magnet on the rack, 600mm from the centre of the motor .
3. Using the self drilling TEK screw and washer, attach the magnet to the rack.
4. The space between the lid and the magnet must not exceed 3mm. If it does, place washers behind the magnet to reduce the space.



Do not invert the magnet. Only use the magnet supplied with the operator.

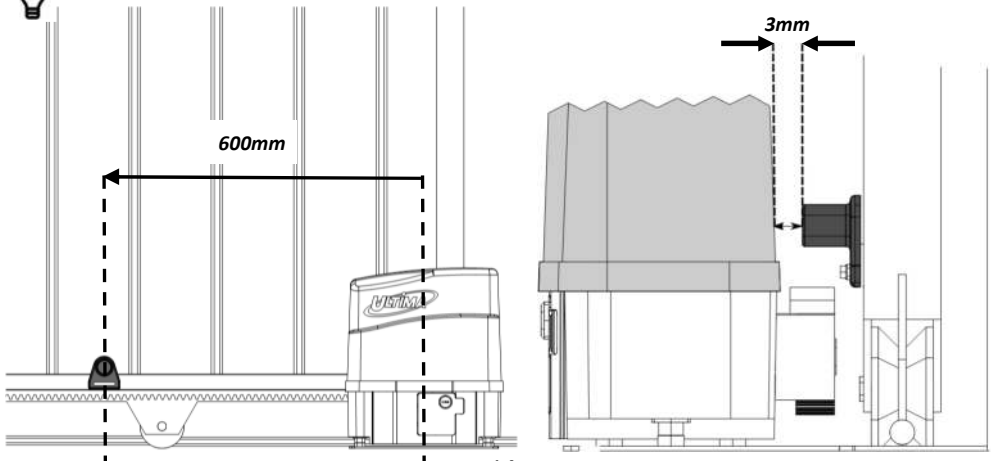

TRITEK CONTROL BOARD LAYOUT

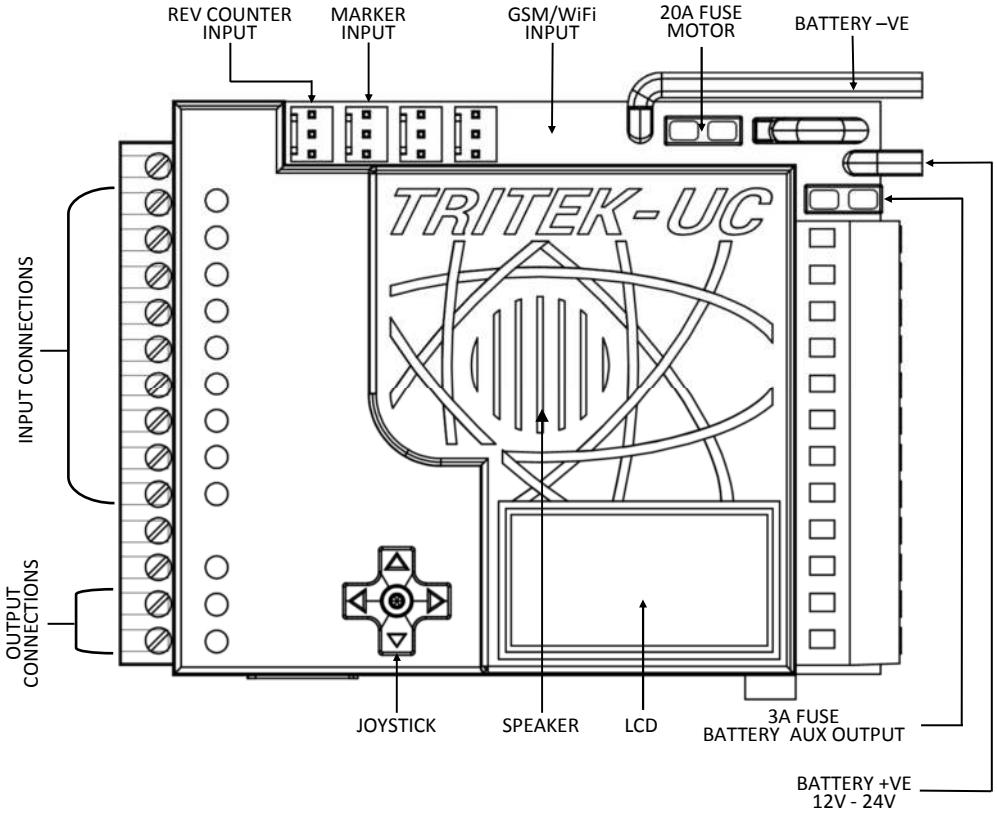

OVERVIEW OF POWER CONNECTIONS & FUSES

- **FUSE 20A:** this fuse protects the motor in the event of a short circuit or excessive overload.
- **FUSE 3A:** this fuse protects the auxiliary battery output in the event of a short circuit or excessive overload.
- **MOTOR 1:** this output is used to drive the motor.
- **BAT-:** this is the battery negative pole.
- **BAT+:** this is a fused 3A auxiliary battery output that is used for powering Electric & Mag locks.

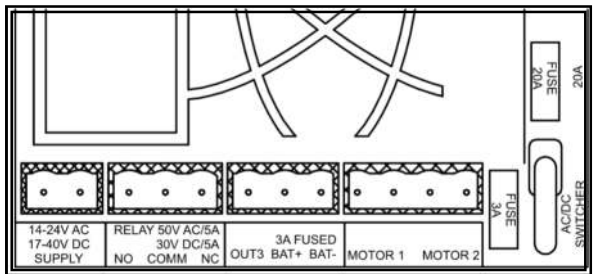

- **OUT3:** this output must be connected to a Relay Module (SA001) for switching Pillar lights & Strobe warning lights. Explore the LCD menus to adjust the many different options available.
- **RELAY:** this output is used for switching Electric or Mag locks.
- **SUPPLY:** Connect 14V AC to 24V AC or unregulated solar power (max. of 40V DC). Minimum supply current 1.5A.

OVERVIEW OF LOW POWER INPUTS & OUTPUTS

- **INF-GND:** this is a dedicated ground, used to connect certain brands of safety beams that have the capacity of performing a self test function, such as the DuraOptics Wireless Beams.
- **INF/CLS:** connect to the safety beam relay or FET output to prevent the gate from CLOSING on an object (collision prevention)
- **INF/OPN:** connect to the safety beam relay or FET output to prevent the gate from OPENING on an object (collision prevention)
- **+BATT:** this output is used to power up all auxiliary devices. It is capable of sourcing a maximum of 300mA. **CAUTION** - ensure that any equipment that is connected to this output is capable of handling the battery voltage. When changing from 12V to 24V battery, this output voltage will be the same as the battery voltage.
- **LCK/STP:** used to activate and deactivate Holiday Lockout via a keypad, keyswitch or receiver.
- **TRIG:** connect a keypad, keyswitch, receiver or intercom button to this input to allow for FULL opening of the gate. Explore the LCD menus to adjust the many different options available.
- **PED:** connect a keypad, keyswitch, receiver or intercom button to this input to allow for PARTIAL opening of the gate. Explore the LCD menus to adjust to the many different options available.
- **LOOP:** this input is typically used in a business complex where a vehicle drives over a Ground Loop to trigger the gate open. This input can be made inactive through the Time Manager feature.
- **C/LIGHT:** the Courtesy Light input can be switched on with a keypad, receiver or a N/O(normally open) push button. It is used to switch on lighting through the relay module (SA001 - OPTIONAL). Explore the LCD menus to adjust the many different options available.
- **TAMPER:** to alert any tampering, the Ultima operator has a receptacle to fit an optional Microswitch that can be connected to the Tamper & Ground inputs. This will trigger the alarm output if lid tampering is detected.
- **COM-GND:** connect all ground wiring from auxiliary equipment to this input.
- **STATUS:** fit an external LED in a convenient place to indicate when the gate is closed, open or in motion.
- **ALARM:** this is an output that can be connected to a wired transmitter to trigger the house alarm or a relay module that drives a siren. It will be triggered if any of the security functions are breached. Explore the LCD Security menus to adjust the many different options available.
- **PULSE:** a very useful output that will trigger every time the gate is operated. It is typically used to trigger external devices such as a buzzer, garden beams bypass or even to synchronise two gates.

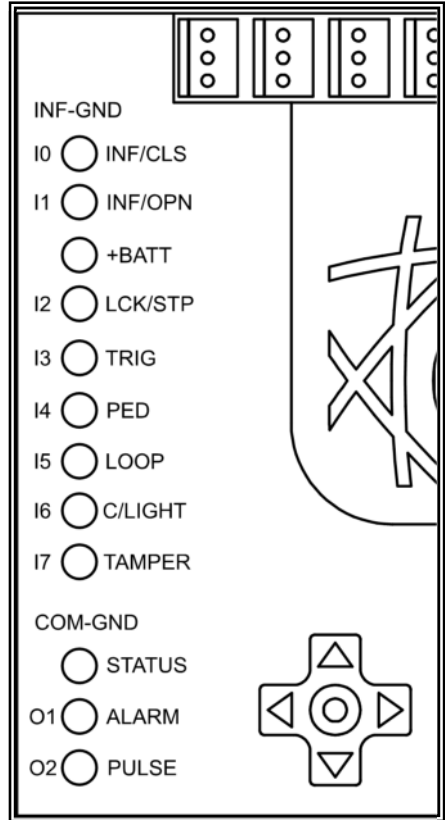

CHARGING SUPPLY OPTIONS

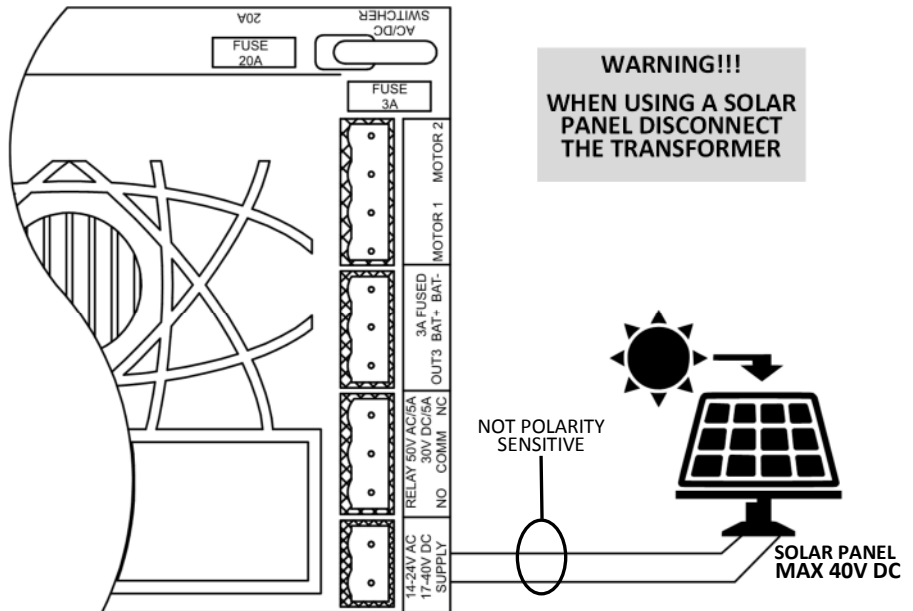
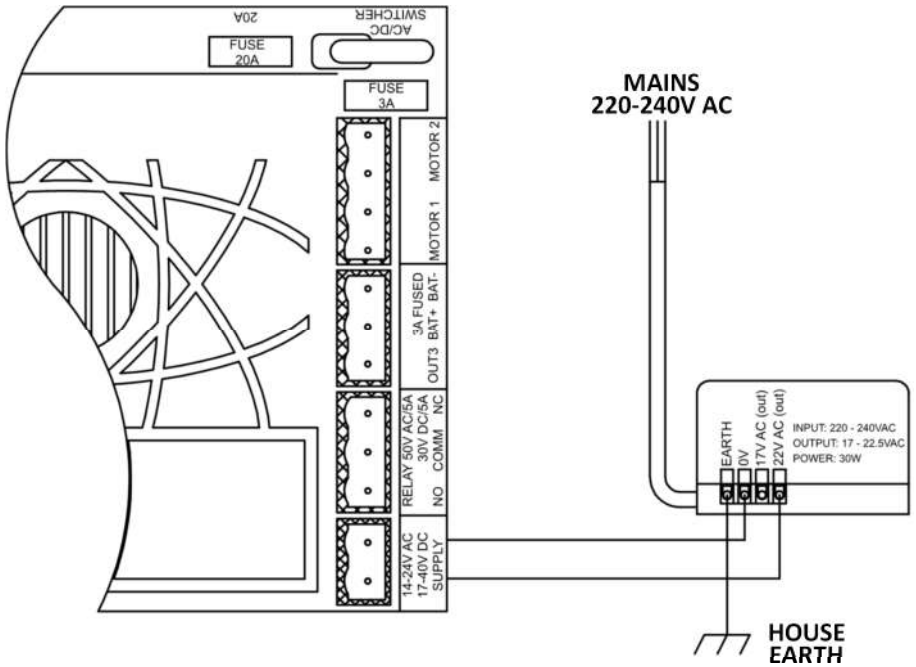

MENU NAVIGATION OVERVIEW

IDLE MODE:

The LCD screen will remain in Idle Mode if the Joystick has not been moved for awhile and will scroll through the following 3 screens.

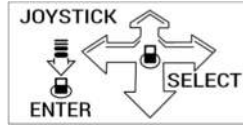

JOYSTICK MENU NAVIGATION:

The Joystick moves in 5 directions: UP (North); DOWN (South); LEFT (West); RIGHT (East) for navigation and INWARD (Press) for item selection.

Moving the Joystick while the screen is in Idle Mode will activate the Quick NAV screen

Pressing the Joystick while the screen is in Idle Mode will act as a trigger test button.

QUICK NAV SCREEN:

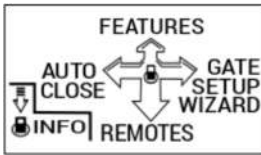

This screen navigates you through the most commonly used functions and features:

GATE SETUP WIZARD (RIGHT/ East):

On new installations the Gate Setup Wizard must be run first before the operator can be used. This function programs the gate limits into the controller.

FEATURES (UP/North):

All the controller features and functions may be accessed from this screen. This shortcut will take you to the MAIN SETTINGS screen where all the controller features are available .

REMOTES (DOWN/South):

This shortcut will take you straight to the REMOTE SETTINGS screen from where you can add new remotes to the system.

AUTO CLOSE (LEFT/ West):

All the auto close (AC) features may be adjusted from within the AUTO CLOSE SETUP screen. During installation it might be useful to temporarily disable auto close from here.

INFO (INWARD/Press):

This gives real time information regarding the status of the operator. From this screen you can get information such as the current battery voltage, main supply voltage and gate status.

INFORMATION SCREEN:

The information screen provides real time information on the current status of the controller. By using the joystick to scroll left or right, the various categories below can be selected. Pressing the joystick in will cause the controller to bring up the function menu associated with the highlighted category.

Continues.....

.....continued

INFORMATION SCREEN MENU ICONS:



Battery - Displays the current battery voltage, charge current and charge voltage.



Mains Supply - Displays the current type of supply, supply voltage and output voltage.



GSM / WiFi - Displays the status of the GSM or WiFi module connected to the controller



Gate - Displays the number of operations, average force and maximum force of the gate while running



Receiver - Displays information about the last remote signal that was received.



Time Manager - Displays the current date, time and active timer events.



USB - Displays information regarding any connected USB devices.

COMMISSIONING THE OPERATOR FOR THE FIRST TIME

Step 1: Programming the gate limits with the Setup Wizard

- => Connect the battery power
- => Connect the charge power (transformer/solar)
- => The controller will automatically begin the Setup Wizard
- => Follow the voice prompts until complete

Step 2: Set Collision Sensing

- => From the Quick NAV screen select Features



- => Select Gate Setup



- => Select Safety Settings

- => Refer to page 39 for information on setting Closing Force and Opening Force.

Note: If the gate needs to be reprogrammed, select GATE SETUP WIZARD on the QUICK NAV screen and follow the voice prompts.

Step 3: Programming a Remote to trigger the gate

- => From the Quick Nav screen Remotes



- => Select Add Remotes

- => Press SET for Teach Single Function to Remote Button



- => On SELECT FUNCTION screen press SET for Trigger

- => Hold the Joystick UP (North) while pressing the button on the remote which is to be programmed

Note: if multiple remotes are to be programmed, continue to hold the Joystick UP (North) until all the remotes have been programmed to the operator.

Please refer to page 30 in this manual to learn more on Remote Settings.

The operator has now been commissioned and can be triggered by the remote. Read further in the Instruction Manual to learn about the many functions and features that the Ultima Operator has to offer.

TWO SETS OF SAFETY BEAMS (RELAY OUTPUT)

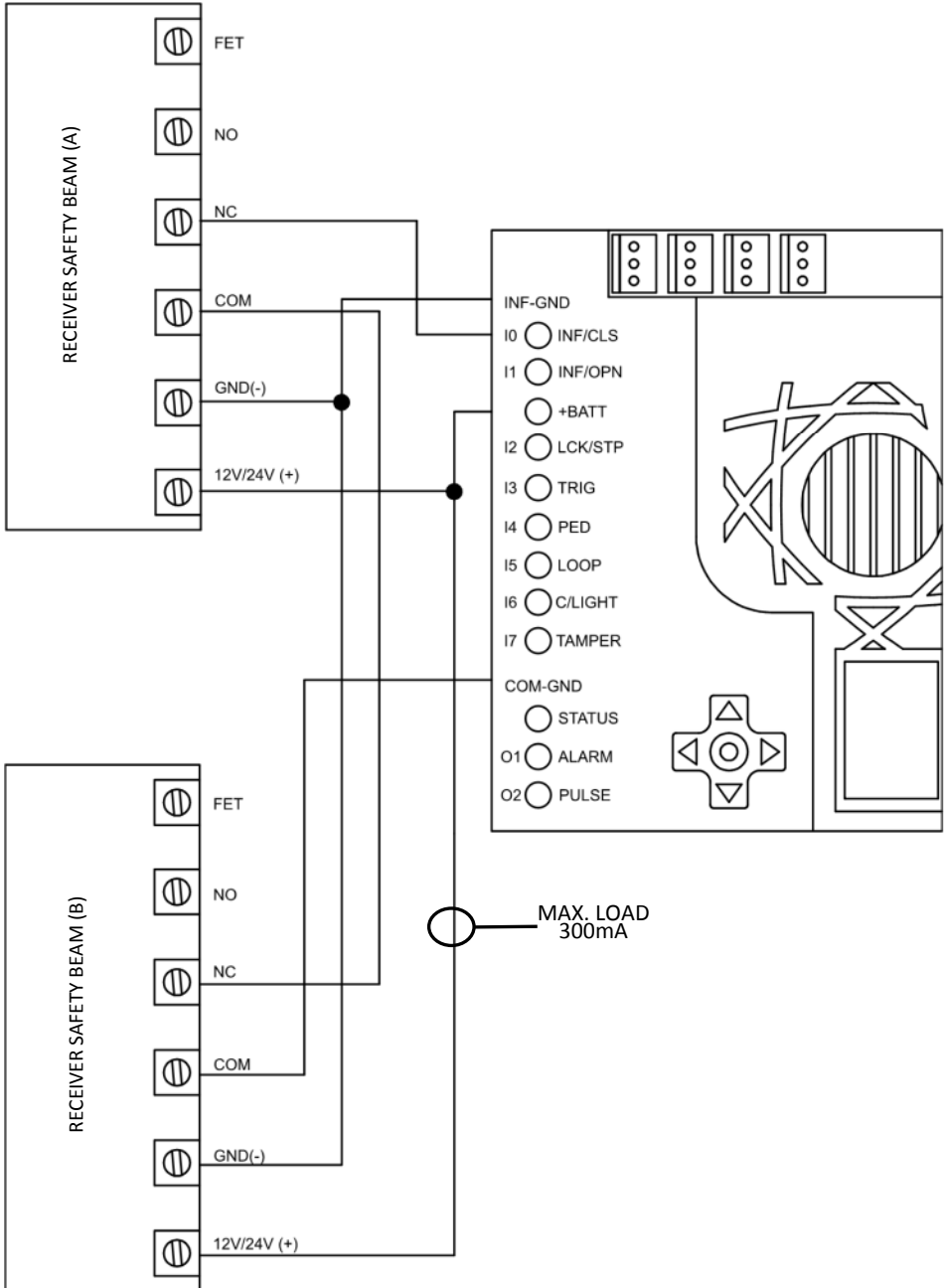

EXTERNAL RADIO RECEIVER & LOOP DETECTOR

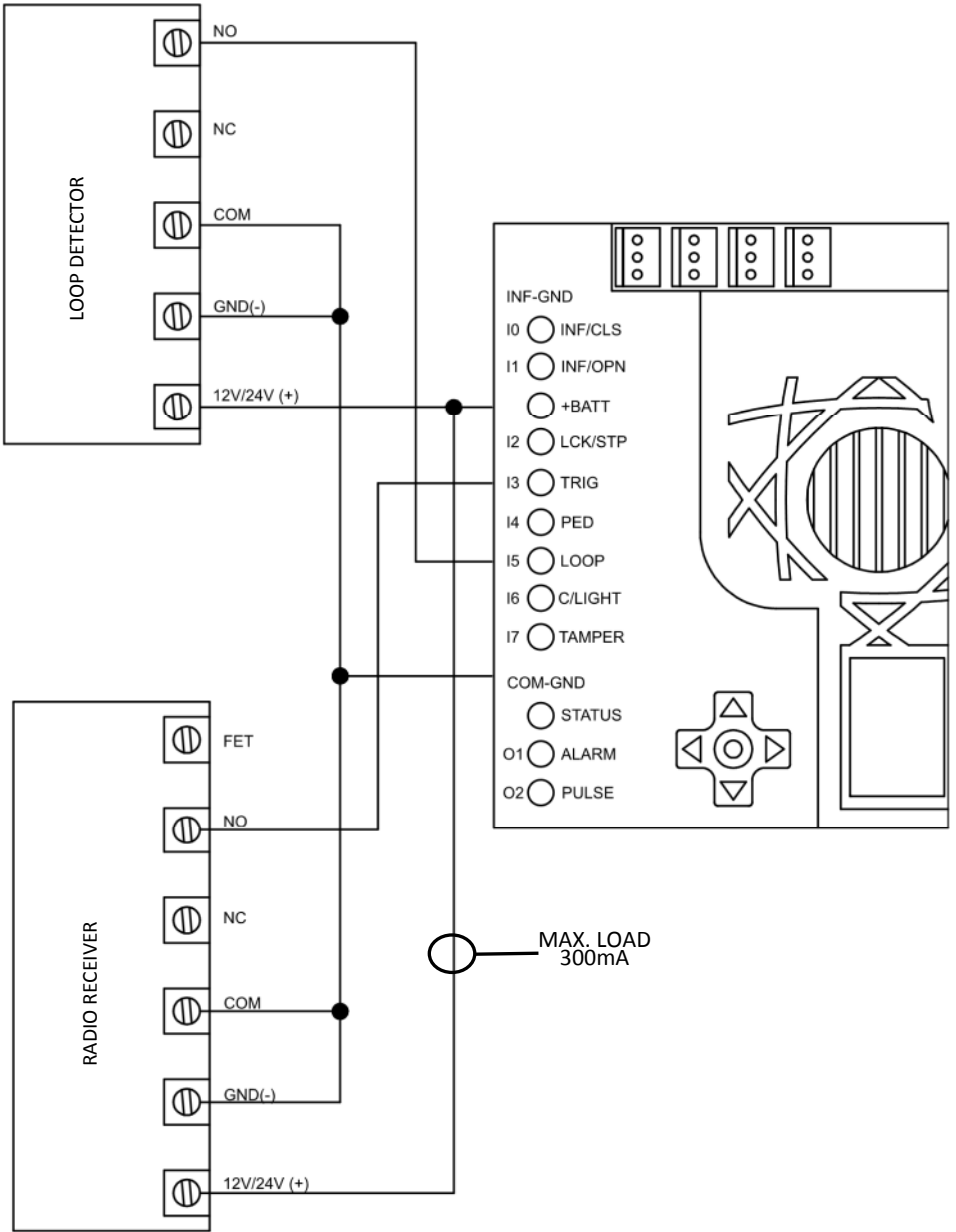

CLOSING SAFETY BEAM (FET OUTPUT)

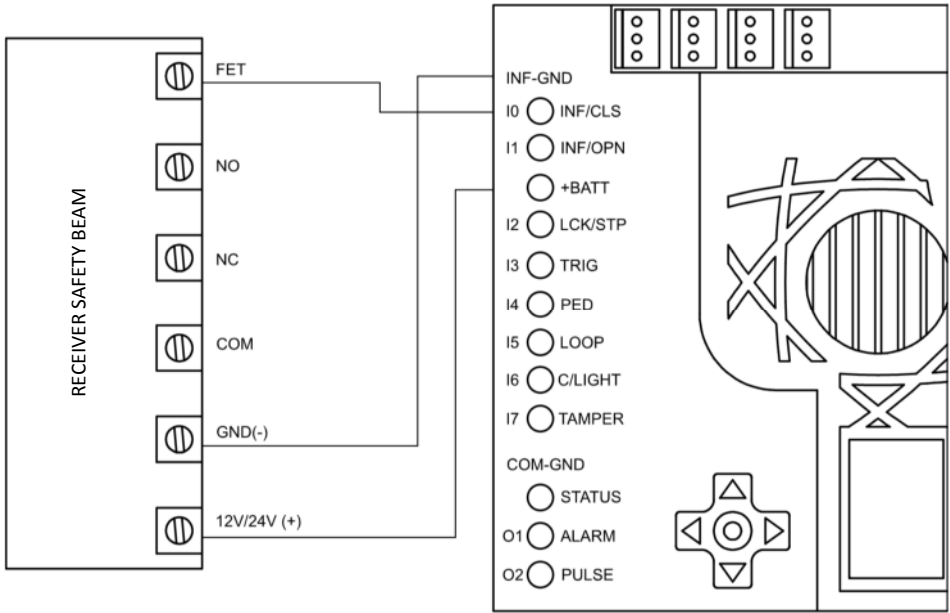

CLOSING SAFETY BEAM (RELAY OUTPUT)

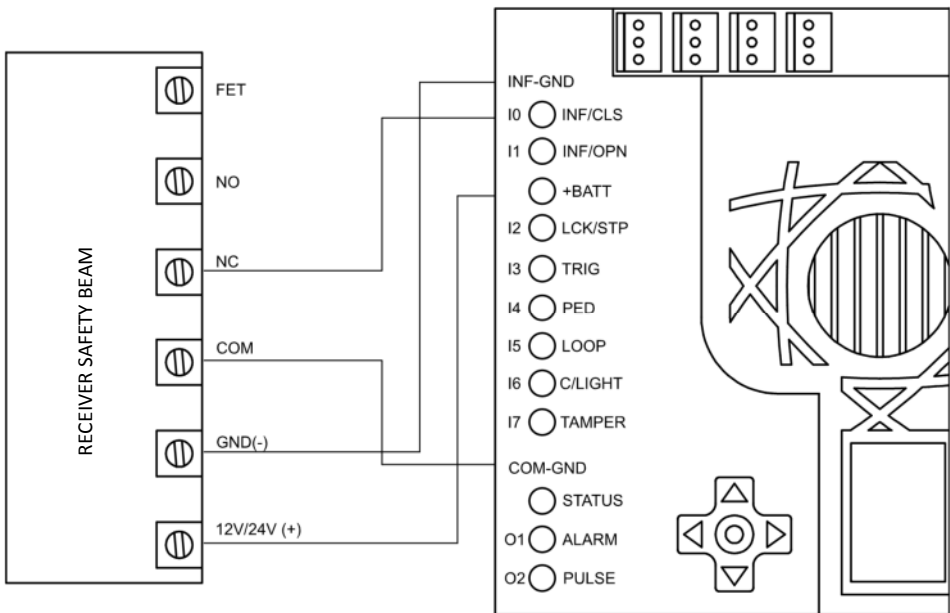

OPENING SAFETY BEAM (FET OUTPUT)

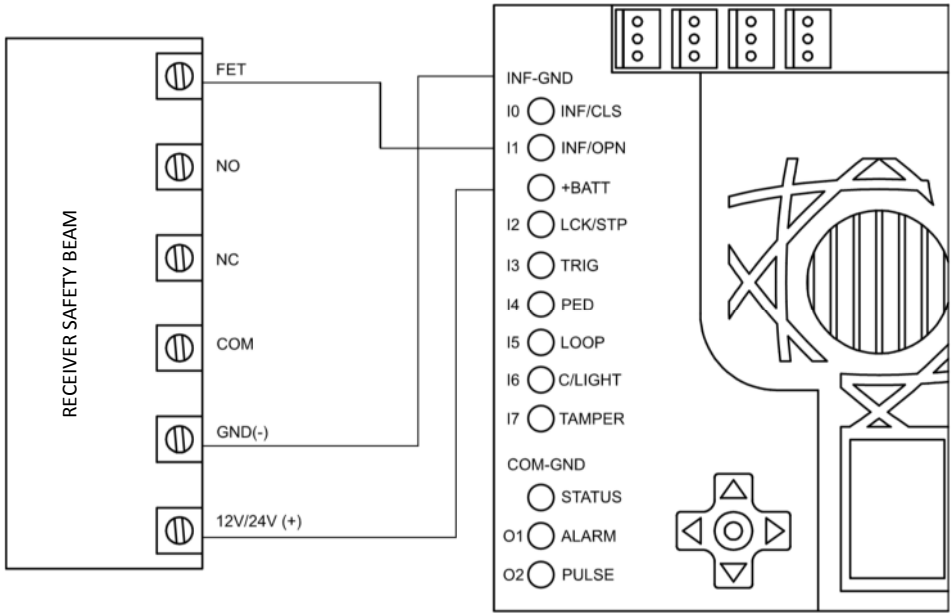

OPENING SAFETY BEAM (RELAY OUTPUT)

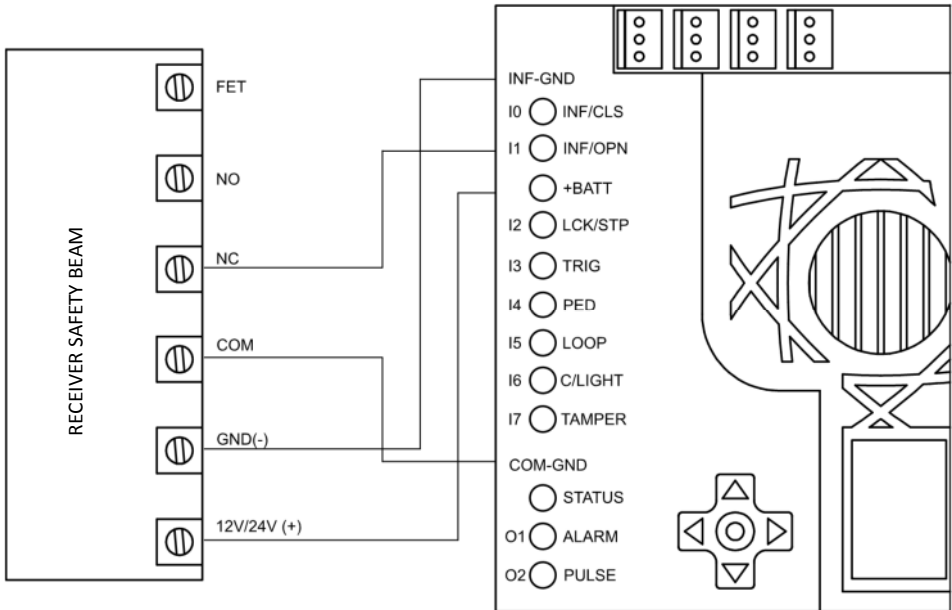

CONNECTING COMMON EXTERNAL DEVICES

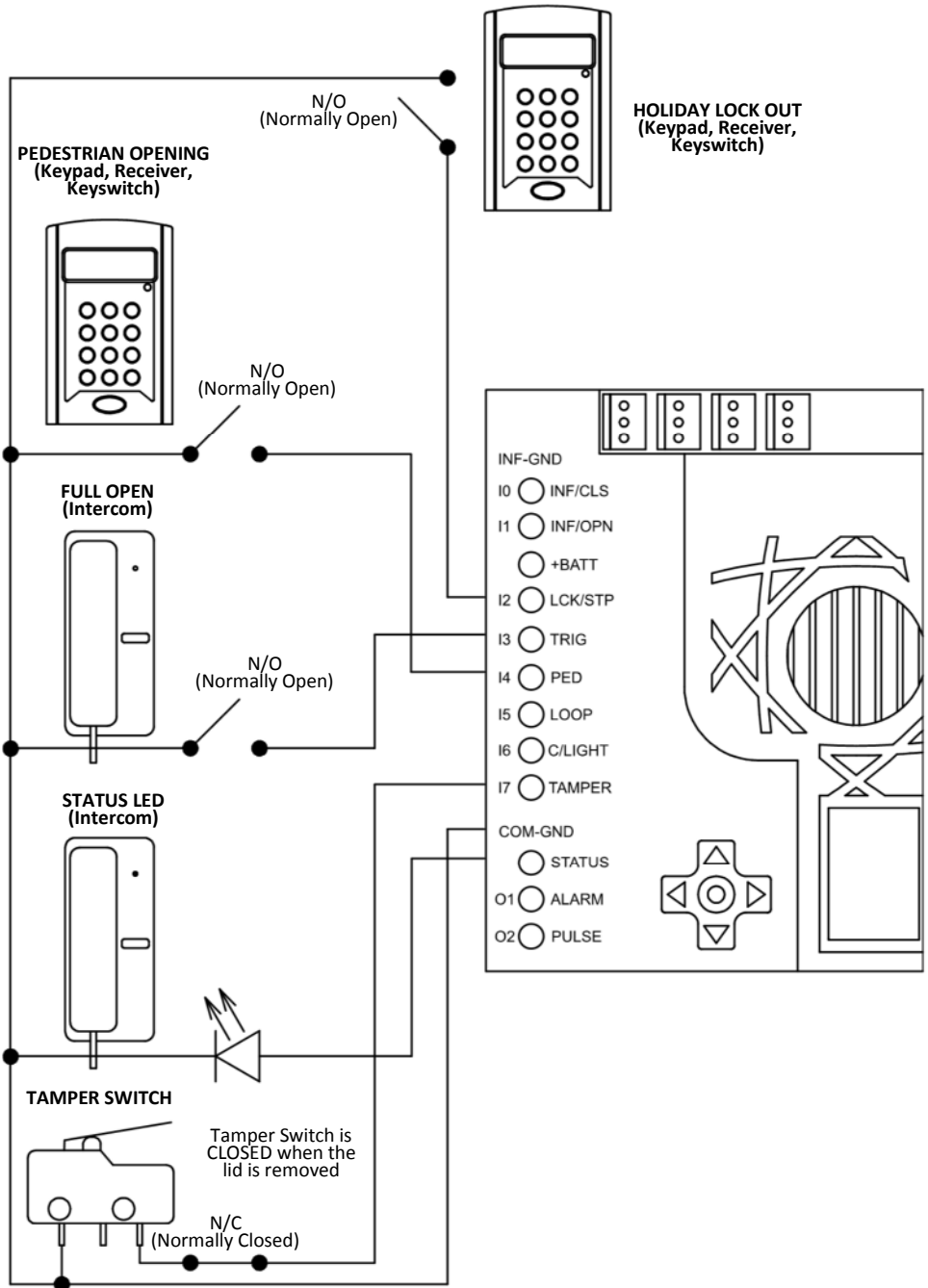

CONNECTION FOR RELAY MODULE

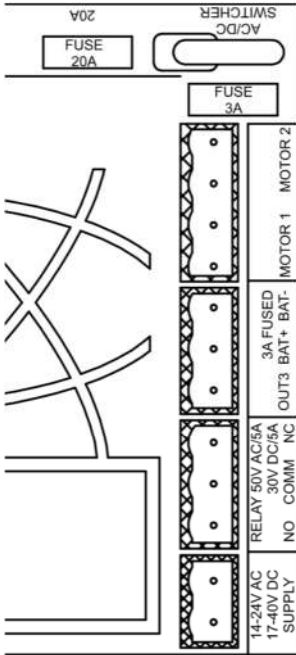

OUTPUT DEPENDANT ON VOLTAGE OF BATTERY FITTED.
ENSURE ALL EXTERNAL DEVICES ARE CORRECTLY RATED.
MAX. LOAD of 100mA

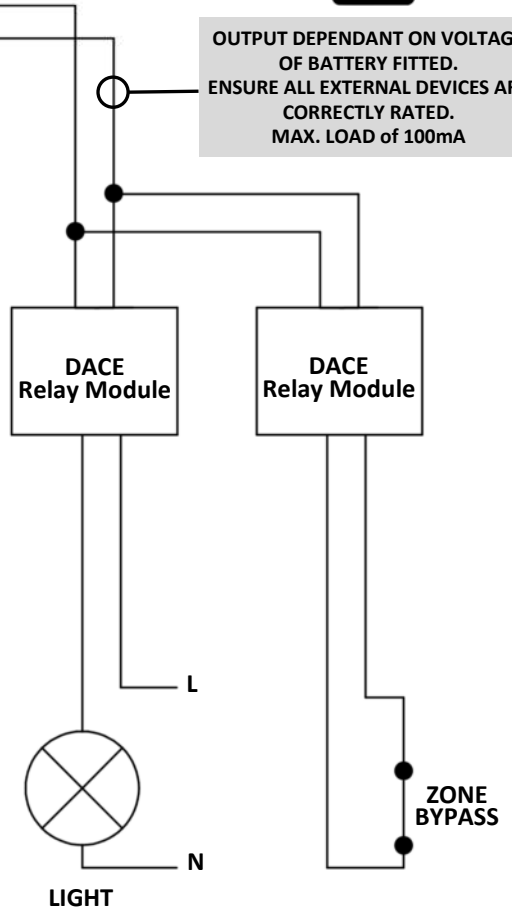

ELECTRIC LOCK

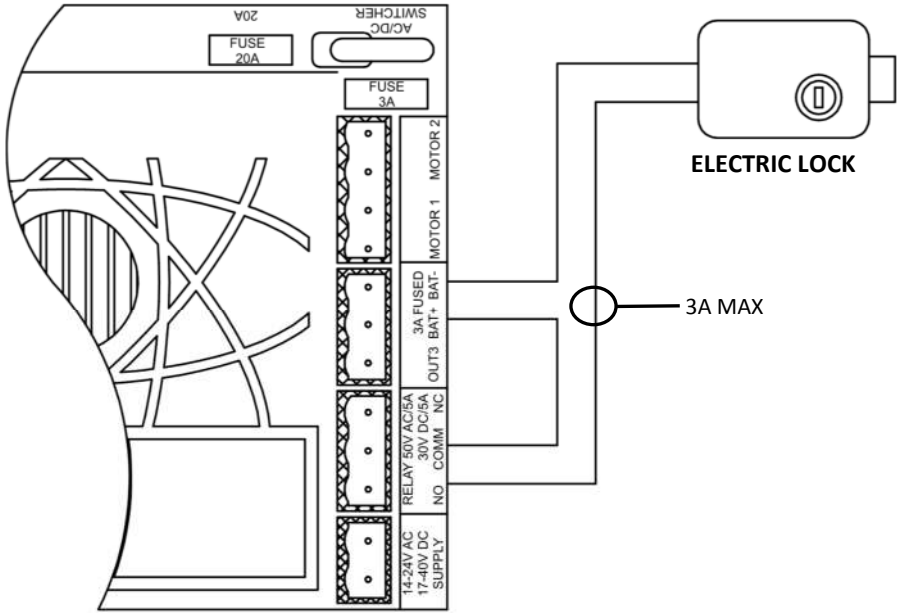

MAGNETIC LOCK

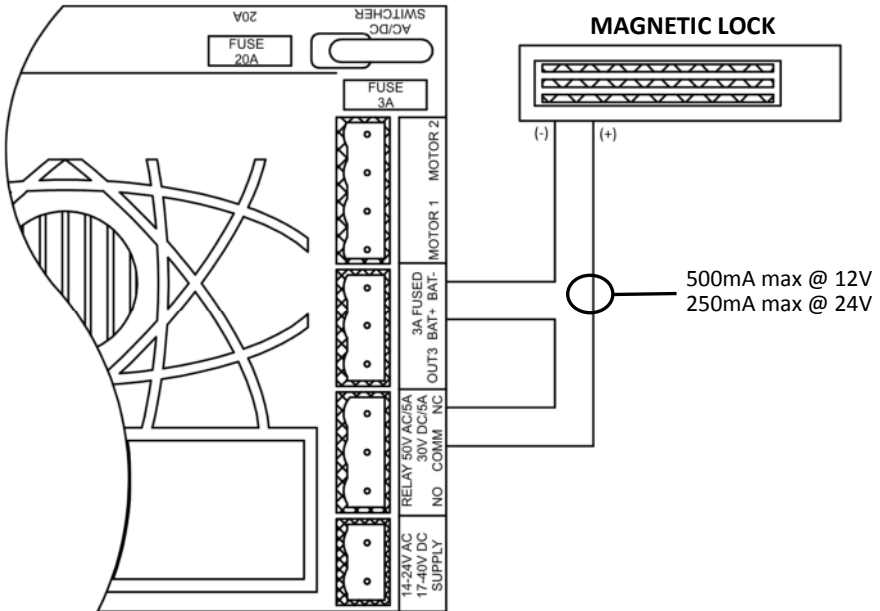

CONNECTING VARIOUS DEVICES TO PULSE & ALARM OUTPUTS (USING RELAY MODULE)

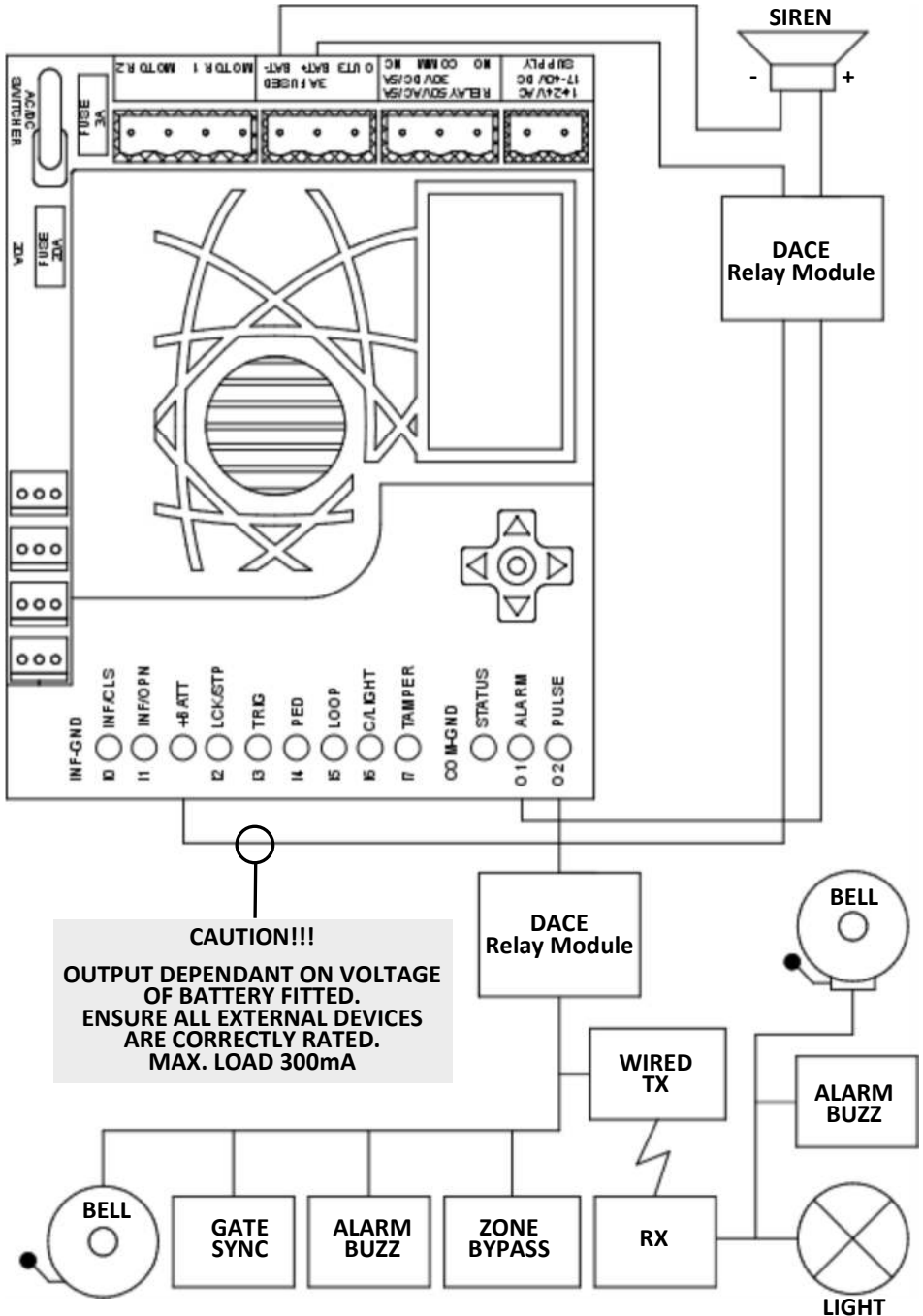

TWO SYNCHRONISED OPERATORS CONNECTED TO ONE SET OF SAFETY BEAMS (USING BEAM RELAY OUTPUT)

WARNING!!!
ONLY CONNECT +BATT
TO ONE MOTOR AS
SHOWN

OPERATOR CONTROL BOARD NO. 1

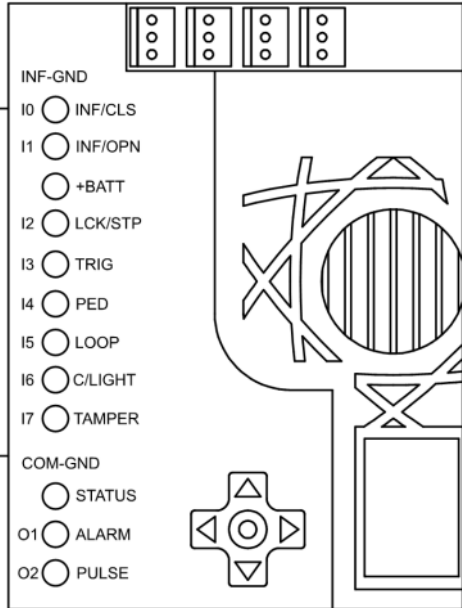

OPERATOR CONTROL BOARD NO. 2

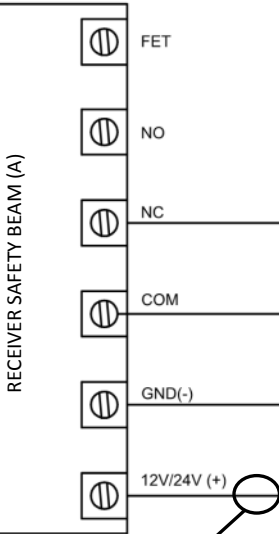
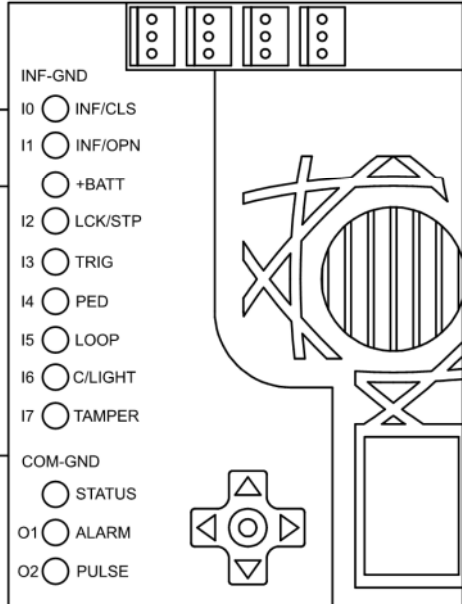

MAX. LOAD
300mA

WARNING!!!
ONLY CONNECT BEAMS
RECEIVER GND TO TRITEK
COM-GND

Note the following functions on the TRITEK menu:



Help

To get help on any of the onboard functions, move the cursor to the specific icon for which more information is required. If the cursor is left standing on the same icon for more than six seconds, a help screen will automatically appear. To exit the help screen move the cursor again.



Undo

The undo function will restore all the settings of the controller to six hours prior. This is useful if settings were changed but it is necessary to revert back to the original settings. **Note:** All changes made in the last six hours will revert back and not just the last item that was changed!

CONTROL BOARD FUNCTIONS

BEAM SETTINGS



The use of Safety Beams on all installations is recommended.

To prevent accidents, Safety Beams must be used when enabling Auto Close.



The controller automatically detects when Safety Beams are connected and holds these in memory. If the beams are removed and not replaced, it is necessary to run a Reset Beams (see below). This function will detect the beams are missing and remove them from memory. If this is not done, they will remain in memory and the controller will believe there to be "faulty" beams in place.



Beams Auto Close

This feature closes the gate automatically as soon as an object has passed through the beams.



Beams AC Time

This feature extends the delay after an object has passed through the beams until the gate closes. The delay can be extended from 1 to 3600 seconds.



Beams AC Reverse

Only optional if Beams Auto Close is active. If Beams AC Reverse is enabled, the gate will slowly reverse back to the open position if it was closing when the beams are blocked. If disabled, the gate will only reverse back the programmed Back Off Distance.



IRBC Is Also IRBO

With this function enabled the Closing Beam will function as both Opening and Closing Safety Beams.



Close IR Reverse

If Close IR Reverse is enabled, the gate will reverse back to the fully open position if the Closing Safety Beam is blocked while the gate is closing. If it is disabled, the gate will only reverse back the programmed Back Off Distance (see below).



Open IR Reverse

If Open IR Reverse is enabled, the gate will reverse back to the fully closed position if the Opening Safety Beam is blocked while the gate is opening. If it is disabled, the gate will only reverse back the programmed Back Off Distance (see below).



Back Off Distance

This function allows for the setting of a back off run distance of between 0.06 - 3m. See Open & Close IR Reverse above.



Self Test Mode

If enabled, the controller will test the Safety Beams before closing the gate. This prevents accidental closure of the gate on an object should the beams be faulty.

Only compatible with DuraOptics Wireless Safety Beams (with dipswitch settings).



Test Beam

When enabled, the controller will run a test on the Safety Beams to see if they are functioning properly.

Only compatible with DuraOptics Wireless Safety Beams (with dipswitch settings).





Reset Beams

The controller automatically detects when beams are connected to the system. Once detected, the beams cannot be disabled unless the Reset Beams function is activated.

AUTO CLOSE SETUP

 To prevent accidents, Safety Beams must be used when enabling the Auto Close function.

AUTO  **Enable Auto Close**
Enabling this function allows the gate operator to Auto Close. If the gate is obstructed and Safety Beams are connected, the Auto Close Time delay will reset when the obstruction is removed.

 **Auto Close Time**
This feature delays the closing of the gate when Auto Close is enabled. The delay can be set from 1- 600 seconds. If beams are connected, the timer will reset each time the beams are blocked.

FULL  **AC On Full Open**
If enabled, the gate will Auto Close from the fully open position.

PART  **AC On Part Open**
If enabled, the gate will Auto Close if it was stopped while still opening.

PART  **AC On Part Close**
If enabled, the gate will Auto Close if it was stopped while it was closing.

 **Allow Party Mode**
'Party Mode' is a feature which overrides Auto Close. By enabling the Allow Party Mode function, it is possible to place the operator into Party Mode with the Trigger button on the remote.

REMOTE SETTINGS

Up to 1024 Remotes can be added to the TRITEK onboard Receiver.

 The TRITEK controller uses Remote Grouping for managing remote access. All remotes must be programmed to a group for it to function. By default, all remotes will be programmed to the Master group, Group 0, unless a new group is created. If groups have been created, the controller will prompt the user to select the group into which the new remote must be programmed.

 If Groups are being used, it is important to keep track of your remotes. This can be done by writing down the remote number seen on the LCD screen during programming and engraving the remote number on the back of the remote. This is helpful when you wish to delete a lost/stolen remote.

 **Add Remotes (No groups)**
If a new group has not been created, the controller will prompt for a Program Method by which to add the new remote/s.

First Method: Teach Single Function to the Remote Button. This will program a single function to a button. It begins at Function 1, which is Trigger, and scrolling left will run through all the available functions up to 16. These include Pedestrian Trigger, Alarm Activate, Party Mode, Light Trigger etc.

Having selected the particular function required, the controller prompts to hold the Joystick Up (North) and, while holding the joystick in this position, add the remote/s by pressing the button that is required to perform the selected function.

Second Method: Duplicate Group Functions to Remote. This will duplicate the functions already setup on the existing remotes in Group 0 to the new remote now being programmed.

When selected, the controller prompts to hold the Joystick Up (North) and, while holding the joystick in this position, the existing functions are duplicated onto the new remote by pressing any button on it. All functions in Group 0 will be copied onto the new remote.

The default function settings for Group 0 are:

- | | | |
|-----------------|-----------------------|---------------------|
| 1. Trigger | 2. Pedestrian Trigger | 3. No Function |
| 4. No Function | 5. Holiday Lockout | 6. Alarm Activate |
| 7. No Function | 8. No Function | 9. Alarm Activate |
| 10. Party Mode | 11. No Function | 12. Light Trigger |
| 13. No Function | 14. No Function | 15. Remote Joystick |

The function number relates to the remote button number or button configuration as illustrated.

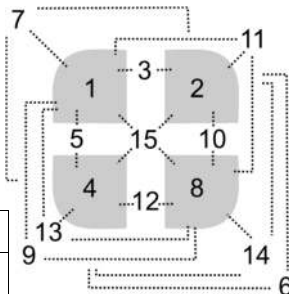

1 = 1	2 = 2	3 = 1 + 2	4 = 4	5 = 1 + 4
6 = 2 + 4	7 = 1 + 2 + 4	8 = 8	9 = 1 + 8	10 = 2 + 8
11 = 1 + 8	12 = 4 + 8	13 = 1 + 4 + 8	14 = 2 + 4 + 8	15 = 1 + 2 + 4 + 8

Continues.....

.....continued



Add Remotes (With groups)

If the controller has more than just the original Group 0, it will prompt for the group number to which the new remote/s must be added. After selecting the required group number follow the same steps as listed in Add Remotes (No groups).



When Duplicating Group Functions to a Remote, it is possible to change the button function assignment by editing each remote individually. It is not, however, possible to add a function to that remote if the function is not available to the group. When removing or adding functions to a group, all remotes in that group will be affected. As an example, by removing the Trigger function from a group, the Trigger function on all remotes in that group will be removed.



Delete Remotes

This feature allows remotes to be deleted by selecting the remote's number in the controller. Only remotes in the system are available for deletion.



Edit Remotes

After a remote has been added to a group, it can be customized by reassigning the button functions of the remote. It is not, however, possible to add a function to that remote if the function is not available to the group. If a remote requires a function that is not in the group, the function can be added to the group using the Edit Group function before assigning it to the button.



Auto Learn Remotes

This feature allows for the learning of remotes onto the controller for a set period of time. The time allowed is set up when the feature is enabled and allows for up to 30 days. Two learn methods are available:

Auto Learn

This method will accept, and learn, any EXO remote that transmits its code in the near vicinity. This is useful if a controller is replaced but not all the remote holders are available to learn their remotes into the controller memory and there is no security guard in attendance to assist.

Buddy Learn (this is the recommended method)

This method is similar to the Auto Learn method but, in order for a remote to be learned, it is necessary for a button of a remote already in the system to be pressed first and then the new remote's button to be pressed within 10 seconds. This is a more secure way of programming the controller and is ideally suited for a complex with a security guard in attendance. It is far less likely that unknown remotes are accidentally programmed on to the controller.



Edit Group

The TRITEK uses a grouping system for managing remote users. This provides a level of security and control if the gate is used by various groups (users). Groups such as the homeowners; domestic worker, garden service, pool service, security guards and more can be created in addition to the master group (Group 0), with 15 groups available.

Access through the gate by each group can be independently controlled and access to the main menu by these groups can be locked, while the remotes belonging to the master group (Group 0) have the ability to access the main menu at all times (see Lock Main Menu).

Each group can be individually customized. For instance, a group created for a domestic worker may only allow the gate to be opened using pedestrian entry, on certain days and during certain times while a garden service group will allow the gate to open fully, on one specific day and for a limited time.

In each group various functions can be assigned to each of the 16 available function slots. These functions directly correspond to the 15 "buttons" of the EXO Remote. Example, if function 1 of a group is set to Trigger then button 1 of a remote programmed to this group will be the Trigger button. If function 2 of the group is set to Light Trigger then button 2 of all the remotes belonging to this group will activate the light.

Function 16 does not match a remote button configuration but can be individually selected by using the edit remotes function. Therefore, some remotes in a group can have a special additional control such as placing the gate in lockout mode, preventing it from closing. By default, any remote programmed to a group will not have access to function 16 and needs to be specially configured to use this function.

It may be temporarily required for all the remotes in a group to be barred from access, for example, when a driveway is being tarred. The Trigger function in the group can temporarily be changed to Pedestrian Trigger so that the users in that group now only have pedestrian access.

Unassigned functions in a group (No Function) means that that button on the remotes will have no function assigned to it. The owner of the remote can therefore assign that remote button to another operation such as a garage operator and will not affect the gate operator.

Continues.....

.....continued



Copy Group

This feature copies the settings from one group, thereby making it easy to set up a new group with just minor adjustments. When setting up a new group for the first time, use the 'Copy Group' function to copy Group 0, thereby creating a new group, and then use the 'Edit Group' function to customize the new group.



Clear Group

This feature clears all the functions assigned to a group, effectively disabling all remotes belonging to that group. It does not, however, delete the remotes so reassigning the functions will re-enable the remotes belonging to the group.



Lock TX Menu

This feature prevents unauthorised users from adding new remotes. Only users in the master group can add remotes when the Lock TX Menu is enabled. To enable this function a minimum of two remotes must be programmed to Group 0.



Lock Main Menu

If this function is enabled, only users belonging to Group 0 can make changes to the controller. To enable this function a minimum of two remotes must be programmed to Group 0.



Lock Receiver

Enabling this feature will lock the onboard receiver. By locking the onboard receiver, any remote that does not belong to Group 0 will be disabled. Remotes belonging to Group 0 cannot be disabled (see EDIT GROUP instead).



Erase all Remotes

This function erases all remotes currently programmed to the controller.

PEDESTRIAN ENTRY



Pedestrian Gap

This function allows you to set the distance the gate will travel when opening for pedestrian access. This can be set from 0.3 to 3m wide.



Pre Open Delay

Use this function to set a 0 - 65 second delay between the activation of Pedestrian Trigger and the actual opening of the gate to the pedestrian open position. This is useful if a Pedestrian Trigger button is located some distance away from the gate, such as on an intercom inside the building, and allows the pedestrian to walk to the gate before it starts opening.



Pre Close Delay

Use this function to set a 0 - 65 second delay between the activation of Pedestrian Trigger and the closing of the gate from the pedestrian open position. This is useful if a Pedestrian Trigger button is located some distance away from the gate, such as on an intercom inside the building, and allows the pedestrian to walk to the gate before it starts closing. A light can be connected to the controller which will give warning flashes during the set time delay.



Closing Speed

For pedestrian mode, use this function to adjust the closing speed of the gate from between 5 and 20 meters a minute.



PED Closing Force

This function sets the Collision Sensing sensitivity when closing in pedestrian mode. This setting is generally more sensitive than the normal closing force.



Enable Auto Close

Enabling this function allows the gate operator to Auto Close when in pedestrian mode. If Safety Beams are connected, the Auto Close Time delay will reset every time the beams are obstructed.



PED Auto Close Time

This feature delays the closing of the gate when in pedestrian mode. The delay can be set from 1- 600 seconds. If Safety Beams are connected, the timer will reset after the pedestrian has passed through.



Beams Auto Close

This feature closes the gate automatically as soon as the pedestrian has passed through the beams.



Close IR Reverse

If Close IR Reverse is enabled, the gate will reverse back to the pedestrian open position if the Closing Safety Beam is blocked while the gate is closing. If it is disabled, the gate will stop and not reverse back. This is used to 'pinch' off an entry being used by opportunistic pedestrians.

LIGHT SETTINGS



Courtesy Light

Usually used to switch pillar lights on when the operator is triggered. The light output must be connected to an EXO Relay Module. Do not connect mains directly to the controller.



Set Light Timer

This function sets the length of time that the light will remain on if the Courtesy Light option is enabled.



Flash On Moving

If enabled, the light connected to the light output on the controller will flash while the gate is moving.



Pre Close Flash

If enabled, the light will start flashing before the gate closes if the 'Pre Close Delay' option is set, either via the 'Pedestrian Entry' menu or the 'Gate Setup -> Run Profile' menu.



Pre Open Flash

If enabled, the light will start flashing when the gate is activated if the 'Pre Open Delay' option is set, either via the 'Pedestrian Entry' menu or the 'Gate Setup -> Run Profile' menu.



Flashing Speed

This setting adjusts the flashing speed of the light from 0.25 - 6 seconds. Different types of lights have different response times. Incandescent lights might, for instance, need to be flashed slower than LED lights.



Fluorescent energy saver bulbs should not be used for warning signals. These lights have special circuitry which may be damaged by flashing the light and might also damage the controller. It is recommended that either LED, halogen or incandescent lights are used.

SECURITY SETTINGS

The following Alarm Functions, if enabled, will activate the controller's Alarm output. This output, connected via an EXO Relay Module, can activate a buzzer; siren or house alarm. If a GSM Module is fitted, all alarm signals will be transmitted to selected cell phone numbers.



Ambush Alarm

If enabled, this function will activate the controller's alarm output if any of the Safety Beams are blocked for a period longer than the time set in 'Ambush IR Timer', when the gate is in the open/ing position. This can occur if an intruder blocks the safety beams, when a homeowner enters the property, to prevent the gate from closing.



Break In Alarm

When enabled, this function will activate the controller's alarm output immediately if any of the Safety Beams are blocked while the gate is in the closed position. This effectively makes the Safety Beams perform a function like that of Perimeter Beams.



Tamper Alarm

If enabled, this function will activate the controller's alarm output if the gate operator's lid is lifted up. This feature is only available on operators where the optional tamper switch has been installed.



Gate Open Alarm

If enabled, this function activates the controller's alarm output if the gate remains open for a period longer than the time set in 'Stand Open Time'. This warns the homeowner if the gate is left open or is unable to close (could be as a result of a fault or an obstruction).



Securi-Lock

If enabled, this function will activate the controller's alarm output if the gate is forced open while in the closed position.



Important: To enable this feature, first place the gate in the closed position and move the Marker Magnet (see pg. 14) from the prescribed position on the gate to right in front of the Marker Sensor (see pg.7, part number 14). When the feature is enabled the controller will automatically re-detect the Marker Magnet's position by moving the gate off the marker and returning back to it.



Ambush IR Timer

This timer sets the maximum duration that the beams may remain blocked while the gate is in the open position (See Ambush Alarm) before activating the controller's alarm output (1 sec- 5 min).

Continues.....

.....continued



Alarm Duration

This setting adjusts the duration that the alarm output will remain active.



Hold Alarm

This setting will keep the alarm output activated for as long as an alarm condition persists. The alarm output will only switch off after the alarm condition is removed and the alarm duration time has expired.



Rearm Duration

This setting prevents alarm conditions from continuously retriggering the alarm output. The alarm input will only rearm after the alarm condition is removed and the Rearm Duration has expired.



Stand Open Time

This function sets the maximum length of time that the gate can stand open before the Gate Open Alarm function is enabled thereby activating the alarm output. When setting the Stand Open Time, take into consideration any Auto Close times set and the time required to enter or exit through the gate.

LOCK SETTINGS



Electric Lock

This function enables the use of an electric lock with the operator (see pg. 26 for wiring diagram).



In the event that power to the gate operator is lost, the gate will remain locked and the electric lock will have to be opened manually.



Magnetic Lock

This function enables the use of a magnetic lock with the operator (see pg. 26 for wiring diagram).



In the event that power to the gate operator is lost, the magnetic lock will automatically unlock. Magnetic locks are not suitable for use with solar powered systems. Magnetic locks draw large amounts of power which will significantly reduce the number of times the gate operator can be operated during a power failure.



Enabling the Magnetic Lock function when using an Electric Lock will result in the Electric Lock being damaged.



Off When Open

This function reduces power consumption of magnetic locks by switching the magnetic lock off while the gate is open. The lock will only be switched on again when the gate is closed.



Pre Open Delay

This setting is used to create a short delay before the gate opens, during which time the lock will unlock. This should be applied when using an electric lock to prevent the gate opening before the electric lock has unlocked.



Post Open Delay

This setting allows the gate to move away from the 'locked' position before the locked state is restored to the lock. It is especially useful for magnetic locks that may pull the gate back if re energized before the gate has moved far enough away from the locked position.



Pre Close Delay

This setting is only used where the gate is locked in the open position and needs to be released prior to closing.



Post Close Delay

This setting keeps the lock unlocked for a short period after the gate starts closing. Used with magnetic locks to prevent the gate from slamming shut while closing if the 'Off When Open' setting is not selected.

OPERATING MODES



Standard Mode

In Standard Mode the gate will :

- open if it receives a trigger when in the closed position.
- return to the closed position if it receives a trigger while open.
- stop if it receives a trigger while it is opening.
- reverse to the open position if it receives a trigger while closing.

These may differ after changes are made to other operator settings



Condo/Multi

Recommended in shared dwellings with many users. The Auto Close function must be enabled for this function to operate. In Condo/Multi User mode a trigger input will open the gate but the gate will only close with the Auto Close or Beams Auto Close functions. This feature prevents the accidental closure of the gate on a second user.



Operator Type

When connecting a Tritex controller to an operator that is not a DACE product, use this setting to select the brand and the series of the operator to ensure compatibility. An Interface Module is required to connect the Tritex controller to a non DACE product.

GSM SETTINGS



Add Phone Number

Cell phones that are allowed to communicate with the controller to operate the gate are added via this function. These numbers can be entered manually or the controller can be dialled via the phone, while the function is open, to automatically enter the number. Each number added is allocated a 'User' number (0 - 1023).



Delete Number

Cell phones that are no longer allowed to communicate with the controller are deleted via this function. The cell phone number to be deleted can be entered manually or the controller can be dialled via the phone while this function is open to automatically delete the number.



Delete Num By ID

Cell phones that are no longer allowed to communicate with the controller are deleted via this function by scrolling through the User numbers and Cell phone numbers.



Send Warning Msg

Select the cell phone number/s that are to receive warning messages from the controller as a result of operator faults or alarm conditions via this function.



Balance USSD Number

Enter the USSD number of the controller's sim card service provider in this function. This is the number used for the retrieval of the SMS balance. The controller will now automatically retrieve SIM balances and send this information to the user/s the next time an SMS is sent out. Since an SMS is sent out after the balance is retrieved, the SMS balance will always be 'one' less than reported (this is dependent on the number of phones receiving messages from the controller).

ENERGY SAVING



Disable Sleep Modes

This feature allows you to disable a sleep mode that might have been previously selected.

Light Sleep



This function places the controller into 'Light Sleep' when the input power supply fails. Internal processes and LEDs are switched off but supply to external devices is maintained. Receiver functionality remains normal. Battery standby time is increased by $\pm 100\%$.

Medium Sleep



This function places the controller into 'Medium Sleep' when the input power supply fails. Internal processes, LEDs and external devices connected to the controller are switched off. Receiver functionality remains normal. Battery standby time is increased by $\pm 500\%$.

Continues.....

.....continued

 **Deep Sleep**
This function places the controller into 'Deep Sleep' when the input power supply fails. Internal processes, LEDs and external devices connected to the controller are switched off. Receiver response time is slightly reduced. Battery standby time is increased by $\pm 1200\%$.

 **Solar Sleep**
If enabled, this function allows the controller to enter into the selected sleep mode (Light, Medium or Deep) while the input supply voltage is at a normal level. This is an advantage when the controller is connected to a solar panel and the maximum amount of energy must be diverted to charging the battery.

USB SETTINGS

 It is recommended that a full backup is made of the controller onto a USB Flash Drive or an Android device connected to the USB input. This is particularly important when automating a complex so that all settings can be restored easily should the operator require repairs or replacement.

Check the DACE website regularly for Tritrek software updates. Save the updated software on to a USB Flash Drive or Android device and update the Tritrek controller. Remember to make a full backup of the controller before loading the updated software.

 **Save Users**
Saves all the Remote, Group and Time Management settings onto a USB Flash Drive or Android device.

 **Restore Users**
Restores all the Remote, Group and Time management settings previously saved with the Save Users function to the controller.

 Any users added after the users were last saved onto the USB Flash Drive or Android device will be lost with this operation.

 **Save Settings**
This feature will save only the gate settings, it excludes the user settings i.e Remotes, Groups and Time Management. A useful feature for a contractor who can cut down setup times by using a file of frequently applied gate settings

 **Restore Settings**
Restores the gate settings to the controller previously saved using the Save Settings function.

 The Tritrek controller, by default, generates a Log File. This is a log of the last 1,024 events. These events include user activity, type of operation, times, faults, power loss, alarm activation etc. This can assist with fault finding and the tracking of users entering or exiting the premises.

 **Save Log file**
Saves the Log File to a USB Flash Drive or Android device connected to the USB input.

 **Software Update**
Upgrade or downgrade the current version of software to that saved on a USB Flash Drive or Android device. The software version must be compatible with the hardware level.

 **Save Time Manager**
Saves the Time Manager settings and times to a USB Flash Drive or Android device connected to the USB input.

 **Restore Time Manager**
This function will restore all the Time Manager settings and times saved using Save Time Manager.

 **Backup Controller**
This function does a full controller backup and includes Remotes, Groups, Time Management and the gate settings and times onto a USB Flash Drive or connected compatible Android phone.

 **Restore Controller**
This function restores the controller from a full backup.

HID SETTINGS (Human Interface Device)



Contrast

Adjust the display contrast for better viewing.



Cursor Speed

Adjust the cursor speed for easier selection of icons.



Click Speed

Adjust how fast the joystick reacts to being held down or multiple presses.



Voice Assistant

Enable or disable the Voice Assistant during programming.



Notifications

Enable or disable notification sounds & messages e.g. blocked beams.



Warning Sounds

Enable or disable warning sounds & messages e.g. low battery.

DIAGNOSTICS

Used to run self diagnostic tests on the controller to check all the inputs and outputs. Follow the voice prompts and instructions during the test.

GENERAL SETTINGS



Factory Reset

This function erases all settings and remotes and returns the controller to the original factory default state.



Controller Info

This function displays the controller serial number, the software version and the hardware version.



Enable Demo Mode

In demo mode, the controller will automatically trigger the operator open every minute. The operator can be closed with a trigger input or Auto Close can be enabled.

TIME MANAGER

Time Manager is a powerful feature that allows for time restricted access and function control. With Time Manager it is possible to perform various time dependant tasks such as switching garden lights on at night or allowing limited access to the premises by a domestic worker.

With Time Manager, you can disable any of the 8 Inputs (INF/CLS, INF/OPN, LCK/STP, TRIG, PED, LOOP, C/LGHT or TAMPER) at times you do not wish for that input to be used. It is, for instance, possible to disable the Trigger input at night to stop access through connected keypads after business hours.

Any of the four Outputs (ALARM, PULSE, LIGHT or LOCK RELAY) can also be activated by Time Manager at desired times. The LIGHT output could be used, for instance, to switch garden lights on through a connected relay module during specific hours.

If multiple remote Groups (see Remote Settings) were created, it is possible to use Time Manager to disable specific groups during certain times. If you have a garden service with remote access in one group and a domestic worker that has also got remote access in a different group you can use Time Manager to give your garden service access only on certain days and your domestic worker access on different days and times.

With Time Manager, not only is it possible to control Inputs, Outputs and remote Groups but also specific Functions. It is, for instance, possible to disable the Pedestrian Entry function during certain times. Disabling this function will prevent the opening of the gate by any remote or input linked to the Pedestrian Entry function. This is useful in areas where staff are allowed access to the premises during the day but outside of working hours access is denied.

Using time manager is a great way of enhancing your security as well as automating your environment.

Continues.....

.....continued



Before using Time Manager ensure that the controller Date and Time are set correctly.



Set Time & Date

This function sets the controller time and date.



Set Time Period (120 Periods & Exclusions in total)

Use this function to set up new Time Periods following these steps.

1 Select Period Number:

Select the number of the new period to be created, from 1 to 120.

If a period is already used, the option to OVERWRITE is shown. If the period is not currently in use, the option to CREATE is shown.

2 Type of Period:

Weekly:

This will happen every week on the days set. (Any day, or combination of days, can be selected).

Monthly:

This will happen every month on the days set. The days are set from 1 to 31 and 'Last Day'. If 29; 30 or 31 is set, the controller will notify you that the event will not happen every month. Example, if 30 is set, the event will occur every month on the 30th, except February when the event will not occur at all. However, if 'Last day' is set then the event will occur every month on the last day.

Annually:

This will happen every year on the date set. If the date set is 29 February the controller will notify you that the event will not happen every year.

Once Off:

This will happen once on the date set.

Having selected the 'Type of Period', the controller will ask you to select, where appropriate, the year, month and day.



When multiple periods overlap, the order of priority is 'Once Off' taking precedence, then 'Annually', 'Monthly' and finally 'Weekly'.

3 Set Start and Stop Day, Time and Date

Each period requires Start and Stop inputs. Depending on the Type of Period, this function will request days of the week, hours, minutes, months and dates in the month. Times are based on a 24 hour format. Time periods may extend beyond 24 hours e.g. a period might start at 20h00 on a Friday and stop on 04h00 on Monday morning.

4 Activate or Disable

Activate or Disable a Function, Input, Output, Group or Group Function.

Example of Disable: Disabling the trigger input during a time period.

Example of Activate: Activating the light output during a time period.

5 Finally, select what it is to be Activated or Disabled. If the Group Function is selected, the controller will prompt for the Group number and then the Group function. Only functions in that group are available for selection. (See Edit Group in the remote section.)



Set Exclusions (120 Periods & Exclusions in total)

Setting an Exclusion Period prevents Time Manager from Activating or Disabling any Functions, Inputs, Outputs, Groups and Group Functions in that period of time.

Example, a Time Period may be required to activate an output every Monday, Wednesday and Friday but not if one of the days falls on the last day of the month. By setting an Exclusion for the last day of the month for that output, the desired functionality is achieved.

Setting an Exclusion is the same as setting a Time Period.



Clear Times

This function allows for individual time periods and exclusions to be cleared. Only time periods and exclusions that have been set up previously can be cleared by this function.

GATE SETUP



Setup Wizard

This function automatically programs the open and closed gate limits. The Setup Wizard will run automatically after the first power up of a new operator or after a gate factory reset (see Use Factory Settings). The Setup Wizard can be run anytime the limits need to be relearned. Follow the prompts to complete.



To run the Setup Wizard it is required that the Terms and Conditions are agreed to, these are available in this manual. Ensure that these are read and understood as non acceptance will prevent the commissioning of the operator.



Safety Settings



Closing Force (10 - 100%)

This function sets the maximum torque that the gate operator will exert on the gate while closing. A heavy gate, or one that does not move easily, will require a higher torque setting than a light gate. This setting also determines the force the gate will exert on an object if it obstructs its path when closing, referred to as Collision Sensing. If the setting is too high the gate will strike the object with high force and may cause damage or injury to the obstructing object. If it is too low however, the gate may stop as a result of small interferences such as a pebble or dirt on the track. It is important to set the Closing Force to a level that suits the specific site when commissioning the operator.



Opening Force (10 - 100%)

This function is the same as Closing Force except that it sets the maximum torque that the gate operator will exert on the gate while opening.



Anti-Crush Gap (0 - 0.5m)

This is a safety feature to prevent the entrapment of people or animals by the gate while closing. By enabling this feature the controller will see any trigger received as an Open trigger if the gate was stopped within the Anti Crush Gap while the gate was closing. Only once the gate is outside the Anti Crush Gap will the controller accept a Close trigger.



Dynamic Adjust (10-100%)

Dynamic Adjust is an additional safety setting to prevent the operator from exerting too much force on an obstruction. While The Opening Force and Closing Force functions set a fixed maximum force limit, this function automatically adjusts, as a percentage offset, from the current running force of the gate while it is running. This means that any unexpected changes in force are detected sooner than if the controller were to wait for the maximum force to be exceeded, as set in the Opening and Closing Force settings. Dynamic adjustment is by default enabled but may be disabled in the Run Profile menu.



Run Profile



During a standard open or close operation, the gate follows the running profile as indicated below. The operator will increase the gate speed during the Ramp Up phase until it reaches its Running Speed. When it approaches its end position, the gate will first Ramp Down and then Crawl until it reaches its end position. Many of these speeds and distances may be adjusted to suit a specific installation. For instance, in a high pedestrian traffic area it may be required to have longer Crawl distance while in a high security area it may be required to have no crawling distance at all.

GATE RUN PROFILE

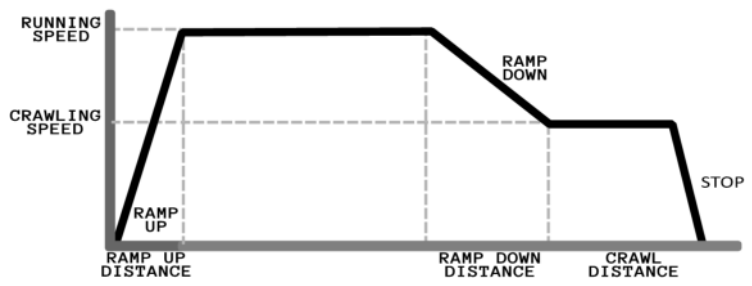

Continues.....

.....continued



Open Ramp Up

Adjusts the Ramp Up distance before maximum running speed is reached when the gate is opening.



Opening Speed

Adjusts the maximum opening speed.



Open Ramp Down

Adjusts the Ramp Down distance before running at crawl speed when the gate is opening.



It should be noted that a very short ramp down may damage plastic rack or place unnecessary strain on the gate motor, especially if the gate is heavy.



Open Crawl Speed

Adjusts the opening crawl speed. This speed should be high enough that the gate does not stall while opening but slow enough that the gate does not stop abruptly when reaching the fully open position.



Open Crawl Distance

Adjusts the Crawl Distance when in the opening mode.



Open Gap Size

Adjusts the space between the gate and the physical 'open end stop' when the gate is in the fully open position.



It should be noted that if the gate is set up to use Positive Close this setting is ignored.



Close Ramp Up

Adjusts the Ramp Up distance before maximum running speed is reached when the gate is closing.



Closing Speed

Adjusts the maximum closing speed. Useful for sites with high pedestrian traffic to reduce the speed.



Close Ramp Down

Adjusts the Ramp Down distance before running at crawl speed when the gate is closing.

See note with Open Ramp Down!



Close Crawl Speed

Adjusts the closing crawl speed. This speed should be high enough that the gate does not stall while closing but slow enough that the gate does not stop abruptly when reaching the fully closed position.



Close Crawl Distance

Adjusts the Crawl Distance when in the closing mode.



Close Gap Size

Adjusts the space between the gate and the physical 'close end stop' when the gate is in the fully closed position.

See note with Open Gap Size!



Trigger Stop Distance

Determines how abruptly the operator will stop if it receives a trigger while the gate is moving by adjusting the final travel distance after receiving a trigger.



A fast, heavy gate can damage plastic rack if it stops too abruptly.



IR Stop Distance

Determines how abruptly the operator will stop if the safety beams are broken while the gate is moving by adjusting the final travel distance after receiving signal from the safety beams.

See note with Trigger Stop Distance!



Dynamic Adjust

Enables or disables Dynamic Adjust (See Dynamic adjust under Gate Setup, Safety Settings).



Pre Open Delay

Sets the delay from the time the controller receives a trigger to the time the operator opens the gate. Typical use is to allow for a warning signal before opening the gate. The controller light output can be set to flash during this period.











Pre Close Delay

Sets the delay from the time the controller receives a trigger to the time the operator closes the gate. Typical use is to allow for a warning signal before closing the gate. The controller light output can be set to flash during this period.

Continues.....

.....continued

- CLOSE**  **Positive Close**
If enabled, the open and close gaps are ignored and the gate will stop touching the end stops. This is usually used in conjunction with electric fencing where it is required that the gate stops against contacts for the electric fence.
- FORCE**  **Positive Close Force**
Sets the force the motor will exert on the end stop when it reaches it.
- CRSH**  **Minimum Reverse Limit**
Sets the distance from the end stops in which the gate will do a full reverse if an obstruction is encountered in normal running mode.
- SPD**  **Mains Fail Speed**
Used to reduce the running speed of the gate should a mains failure occur. This conserves a small amount of power and also provides a visible indication that the main power supply to the operator motor is being interrupted.
- OPEN** 
CLOSE  **Motor Direction**
Reverses the motor direction without having to swap the motor wires around on the controller.
- SLW**  **Slow Open Speed**
Adjusts the speed that the operator will run at when running in Slow Speed in the open direction. The operator runs in Slow Speed when programming the limits, when the controller detects a collision and during the Beam Reverse modes.
- SLW**  **Slow Close Speed**
Adjusts the speed that the operator will run at when running in Slow Speed in the closed direction. The operator runs in Slow Speed when programming the limits, when the controller detects a collision and during the Beam Reverse modes.

USE FACTORY SETTING

Used to restore the Gate Setup to the factory default settings. This will not affect the remote and group settings.

ADDITIONAL FEATURES

HOLIDAY LOCKOUT

When enabled, Holiday Lockout will ignore all triggers received, no matter the origin. There are two methods of activating Holiday Lockout:

Method 1:

Connecting devices, such as a keypad or keyswitch, to the controller via the LCK/STP input.

Method 2:



Program a remote button to the Holiday Lockout function (see Remote Settings pg. 30). Pressing the learned remote button, or combination of buttons, will both activate and deactivate Holiday Lockout.

GROUND LOOP (Loop Detector)

Connected to the controller via the Loop input, a Ground Loop is commonly used for controlling vehicle access (usually exiting), or to prevent a gate from closing on a vehicle. When a vehicle passes over the Ground Loop it triggers the gate open. As long as the Ground Loop is active (ie detecting a vehicle) the gate will remain open.

UPGRADING CONTROLLER SOFTWARE

Step 1: Download the latest version of the Tritex controller software from www.dace.co.za or it can be received by WhatsApp or email.

Step 2: Save the software onto a USB Flash Drive or into the Downloads directory in a compatible Android phone.

Method 1 (DACE preferred method):

Step 3: Remove all power from the controller.

Step 4: Plug the USB Flash Drive or Android phone into the USB port on the controller.

Step 5: Power up the controller by connecting the battery and then the mains power supply.

Step 6: Once the controller has powered up, it will automatically start the upgrade process. Do not remove your phone or Flash Drive until the controller tells you to remove it.



This method can only be used to upgrade to a newer software version.

The controller will only do an upgrade if the hardware is compatible with the new version

Method 2:

Step 3: Navigate to the Update Software option on the USB Settings menu.

Step 4: Plug the USB Flash Drive or Android phone into the USB port on the controller.

Step 5: Press the joystick up to accept Yes on the Update Software option

Step 6: The Controller will run the upgrade process. Do not remove the phone or Flash Drive until the controller tells you to remove it.



This method can be used to upgrade to a newer software version or restore an older software version.

The controller will only make the software changes if the hardware is compatible with the new version.

SERVICE SCHEDULE

The Ultima gate operator, much like a car, will provide many years of excellent service if a service schedule is carried out at regular intervals. Follow these basic checks and do repairs in time to get the most out of your operator.

WEEKLY

- ◆ Clear away any dirt, sand, stones or foliage collected on the gate rail.
- ◆ Clear away any branches, shrubs or grass that might interfere with the movement of the gate.

MONTHLY

- ◆ Check for damage or cracks to the motor lid. Although the operator lid is designed for outside conditions, stones and severe hail may damage it. A cracked lid should be immediately replaced as water and dirt will damage the operator.
- ◆ Check for insect and reptile infestations.



It is recommended that moth balls be placed inside the operator housing to discourage these infestations which can cause damage.

EVERY 6 MONTHS

- ◆ Check for oil leaks.



If the motor was overfilled during commissioning, it is possible that some oil might leak out within the first few months after installation. If oil is visible during this period then clean it away and check again within a weeks to see if more oil is leaking.

- ◆ Test the gate pull and running forces (see pg. 8/9). Compare these values with those previously recorded. If the values are significantly different from when originally installed it might be time to change the gate wheels.
- ◆ Check for battery leaks, these can cause damage to the wiring.
- ◆ Check that the controller and other accessories are firmly in place and are not hanging loose.
- ◆ Check that the Marker Magnet on the gate is tight and not moving. (If it is moving, it must be tightened and the gate limits must be reprogrammed).

Continues.....

.....continued

ANNUALLY

- ◆ Many sealed lead acid batteries do not last for more than one year. The battery condition can be checked by disconnecting the mains supply to the operator. Go to Quick NAV on the LCD screen and press the joystick to enter the Info menu. Run the gate at least five times and then read the battery voltage (BATT. V) to make sure the battery is holding charge. The voltage should read 11.8V or more for a 12V battery and 23.6V or more for a 24V battery.
- REMEMBER TO SWITCH THE POWER BACK ON!
- ◆ Check all guide rollers on the gate.
- ◆ Check all brackets and theft deterrent devices are secure.
- ◆ Check the motor is firmly in place and cannot move.
- ◆ Check the rack for any damage.

NOTIFICATION MESSAGES

MESSAGE	DESCRIPTION
MARKER OK	The Marker Magnet just passed the Marker Sensor and registered.
ARMED	One or more of the alarm inputs is armed and will trigger the alarm output if a valid alarm condition occurs.
ADD A MINIMUM OF TWO REMOTES TO MASTER GROUP	Some functions require a minimum of two remotes in the Master Group for safety reasons. A remote belonging to the Master Group is sometimes needed to unlock a feature e.g. locking the Remote Menu to prevent more remotes from being taught to the system.
MENU LOCK RELEASED	The Menu Lock was released. the menu may now be entered at any time. This will happen if either the Menu Lock was disabled or there are less than two remotes belonging to the Master Group.
PRESS MASTER GROUP REMOTE BUTTON	A button from a remote belonging to the Master Group must be pressed to continue the current operation.
RECEIVER LOCKED, ONLY MASTER REMOTES ALLOWED	If the receiver is locked, only remotes belonging to the master group will be allowed to function.
BEAMS OK	A beams Self Test was performed and the beams are working.
NO TIME PERIODS IN MEMORY	The user wanted to clear a time period but there aren't any in memory.
NEW TX LEARNED	A new remote or device was learned to the controller.
AUTO LEARN MODE EXITED	The Auto Learn time expired or the user manually exited Auto Learn mode that was previously enabled.
SAVING FILE	A file is being saved to the USB device.
LOADING FILE	A file is being loaded from the USB device.
ACTION FAILED	The user tried to save a file to, or load from, the USB device but something went wrong.
FLASH DRIVE NOT READY	There is either no flash drive in the USB port or the flash drive is not formatted using the FAT file format.
REMOTE ACTIVATION	A remote signal was received. The remote number, group and function is displayed.
LIMIT RESET	An end stop limit was reached before expected. Based on this limit position the controller has adjusted it's end stop position.
RUN SETUP WIZARD FIRST	The operator cannot be used until the Setup Wizard is run.

.....continued

MESSAGE	DESCRIPTION
TRIGGER	The operator received a trigger signal.
PEDESTRIAN	The operator received a pedestrian trigger.
LOOP	The operator received a loop trigger.
ACTIVATION IS NOT POSSIBLE WHEN THERE IS A BATTERY FAULT CONDITION	If the battery voltage is too low, the controller will not activate the gate.
ACTIVATION IS NOT POSSIBLE WHEN THE SYSTEM IS IN LOCK OUT	The system is currently in Holiday Lockout. Either the Lockout input, Time Manager or a remote placed the system in Lockout mode. To operate the controller make sure it is not being held in lockout by any of these.
ENABLE AUTOCLOSE FIRST	Condo/Multi User mode cannot be activated if either Auto Close or Beams Auto Close is not active.
DISABLE MULTI USER/ CONDO MODE FIRST	Auto Close cannot be deactivated while Condo/Multi User is active.
PLEASE RUN SETUP WIZARD AGAIN	An action was performed that requires the setup wizard to be run again.
ACTIVATION IS NOT POSSIBLE WHEN THE LOOP INPUT IS ACTIVE	While the loop input is held low (either by a loop detector or Time Manager) other trigger inputs will not close the gate
ACTIVATION IS NOT POSSIBLE WHEN MULTI USER MODE IS ACTIVE	While Condo/Multi User mode is active, other trigger inputs will not close the gate. The gate will only close with the Auto Close setting.
AUTO LEARN ACTIVE	The Auto Learn function is currently active allowing the operator to learn new remotes. To cancel Auto Learn simply press the joystick on the Auto Learn icon in the Remotes menu.
AUTO CLOSE ACTIVE	Auto Close is currently active.

WARNING MESSAGES

MESSAGE	DESCRIPTION & SOLUTION
LOW BATTERY	<p>The battery voltage dropped below the trip point (10V). The battery voltage will need to rise above the recovery voltage before the motor will run again.</p> <ul style="list-style-type: none"> • Check that the main supply is not switched off or possibly has been left off for an extended period of time. It can take a flat battery up to 7 hours to recover. • Ensure the gate moves easily along it's entire path. A worn gate, incorrect installation, worn wheels etc will put a strain on the battery and can cause a low battery. • If this fault occurs continuously and the battery is older than 1 year it may be a faulty battery. Go to the 'Info' screen, if the charge current (CHARGE I) is low and the battery voltage (BATT V) is high but drops when the operator is triggered the battery might be faulty. • Check for loose or corroded battery terminals .
OBSTRUCTION	<p>The controller has detected that the gate has exceeded its running parameters or the gate has encountered an obstruction.</p> <ul style="list-style-type: none"> • Look for an obstruction and remove. • Run the gate in manual override to ensure the gate is moving easily and freely. • Make sure the maximum pull force is not exceeded. • Make sure the gate wheels move freely. • Check the gate rail for stones or sticks. • Make sure the gate enters and leaves the catch bracket easily. • Check that the battery is fully charged. <p>If everything appears in order it may be necessary to adjust the gate force settings. Go to Safety Settings found under Gate Setup on the LCD screen and adjust the opening and/or closing forces.</p>

Continues.....

.....continued

MESSAGE	DESCRIPTION & SOLUTION
<p>CLOSING IR BEAM BLOCKED</p> <p>OPENING IR BEAM BLOCKED</p>	<p>The Safety Beams are blocked or faulty.</p> <ul style="list-style-type: none"> • Remove anything that may be obstructing the beams. • Look on the controller to see what beam input is active. Check that the beam connected to this input is functioning correctly. • Check the beam wiring for corrosion and that the wiring is tight. • Check for insects inside the beam housing. • If the beams are wireless, check the batteries. • Make sure the beams do not exceed their maximum operating range. • Check that the beams are not being affected by sunlight. This usually occurs in early morning or late afternoon if the sun shines directly into the Receiver beam. Some makes of beams, other than DACE, can be affected by fluorescent lights. • If you have multiple beams, make sure they are not cross talking i.e. the receiver from the one set is receiving the signal from two transmitter beams. Transmitter beams may affect adjacent receiver beams if they are not spaced far enough apart. Interference can be checked by blocking one transmitter and seeing if its receiver is still being triggered. • A set of beams may have been removed and 'Reset Beams' has not been activated on the Beam Settings menu. For safety reasons, the controller will never remove beams previously detected without running this feature first.
<p>HOLIDAY LOCKOUT</p>	<p>The controller has been placed into Holiday Lockout mode.</p> <ul style="list-style-type: none"> • If the LED for the LCK/STP input on the controller is active, check any inputs unknowingly activating this function e.g. a keyswitch, a keypad etc. • If the LED for the LCK/STP input is not active then disable Holiday Lockout on a remote by pressing selected button/s • Holiday Lockout might be activated from Time Manager. Clear the active time slot in Time Manager. • Try activating the input device, keypad or keyswitch, and deactivate it again.
<p>MOTOR FUSE BLOWN</p>	<p>The controller has detected that the main motor fuse is blown.</p> <ul style="list-style-type: none"> • Check to see if blown and replace this with an equivalent 20A fuse. • Check that the fuse contacts are free from carbon build up. • Check that the fuse fits tightly in the fuse holder
<p>H-BRIDGE FAULT</p>	<p>The controller has detected that an H-Bridge fault has occurred. An H-bridge fault may occur for various reasons such as the gate being stuck in the open or closed positions.</p> <ul style="list-style-type: none"> • Ensure that the gate moves freely if disengaged. • Check that the battery is charged (Info Screen), the battery voltage should be above 12V. • Check that the motor wires are connected properly and making proper contact. <p>If this fault persists the controller might need to be repaired by a DACE repair centre.</p>
<p>MOTOR DISCONNECT</p>	<p>The controller has detected that the electric motor is disconnected.</p> <ul style="list-style-type: none"> • Check that the motor wires are connected properly and making proper contact. • Check for any carbon build up on the motor wire pins. • Disconnect the motor and try running the motor by touching the motor wires directly to the battery. • If it is an old motor, the motor brushes might be wearing out.
<p>MAINS FAIL</p>	<p>The controller has detected that the mains power is not connected.</p> <ul style="list-style-type: none"> • Make sure the mains supply is on and that the transformer plug point is on. • Make sure the transformer is connected to the controller properly and all wiring is tight. • Check that there is mains at the transformer and that the transformer output is giving out more than 16V AC for a 12V system and 22V AC for a 24V system
<p>PARTY MODE</p>	<p>The controller has been placed into Party Mode with a remote.</p> <ul style="list-style-type: none"> • Press the remote button that has been allocated to the Party Mode function, to deactivate Party Mode. • Press the remote trigger button twice within 4 seconds to take the operator out of Party Mode. • Deselect Party Mode from the Auto Close menu.
<p>ACCESS DENIED</p>	<p>Time Manager has denied an action from a remote. To enable this action, clear the time period affecting this action in Time Manager.</p>

Continues.....

.....continued

MESSAGE	DESCRIPTION & SOLUTION
ENCODER FAULT	The controller has detected an encoder fault. <ul style="list-style-type: none"> • Ensure that the controller is sitting properly on the controller base. • If a Tritek controller is being used on an older DACE product i.e. not an Ultima, check that the encoder is plugged in correctly.
OPENING IR BEAM FAULT	The beams Self Test function is active on the controller and has detected that the opening safety beam is not functioning correctly. <ul style="list-style-type: none"> • Ensure the beams are compatible with the Self Test function. Only DACE compatible beams can be used with this function. • Ensure the opening safety beams are powered up correctly • Check that the opening safety beams are not blocked. • If there are multiple beams in place, make sure there is no crosstalk between the different sets of beams.
CLOSING IR BEAM FAULT	The beams Self Test function is active on the controller and has detected that the closing safety beam is not functioning correctly. <ul style="list-style-type: none"> • Ensure the beams are compatible with the Self Test function. Only DACE compatible beams can be used with this function. • Ensure the closing safety beams are powered up correctly • Check that the closing safety beams are not blocked. • If there are multiple beams in place, make sure there is no crosstalk between the different sets of beams

GLOSSARY

Anti-Lift Device	Prevents the gate from being lifted off the gate rail.
Auto Close	The automatic closure of the gate, not requiring a trigger input.
Battery	Refers to either a 12V or 24V battery that powers the gate operator.
Beams Auto Close (BAC)	The immediate closing of the gate after a vehicle or pedestrian has passed through the Safety Beams, stopping the gate from running to the fully open position unnecessarily.
Catch Bracket	A locating bracket, mounted to the gate post, that holds the gate securely when in the closed position. It can be used as part of an anti lift system or to lock the gate with a padlock when not in operation.
Collision Sensing	The controller software responding to changes in current draw and operator run speed as a result of the gate hitting an obstruction.
Condo Mode	Short for Condominium. See Multi User Mode
Controller	The circuit board containing the electronic components and software that controls the gate operator.
End Stop	A metal device on the gate rail, used to prevent the gate from running off the gate rail in both the open and closed positions.
Foundation Plate	The steel plate used to anchor the operator to a concrete slab.
Infrared Beams:	See Safety Beams
Intercom	Allows for two way communication between the gate and the house.
Joystick	The physical device used to navigate the menu on the controller.
LCD Screen	The graphics screen display on the controller.
Loop Detector	Detects when a vehicle drives over it to trigger the gate open (or closed).

Continues.....

.....continued

Main PC Board	See Controller
Manual Override	Allows the gate to be moved manually.
Multi User Mode	Used in a Townhouse application. The controller will not accept a trigger while opening to prevent the accidental closing of the gate on a vehicle/person.
Operator	Gate motor.
Overcurrent	See Collision Sensing
Party Mode	Allows the gate to remain open when the Auto Close function is active.
Pedestrian Entry	The partial opening of the gate preventing vehicle access.
Pinion Gear	The gear on the operator that meshes with the rack on the gate making the gate move.
Positive Close	The closing of the gate with no gap between the gate and the end stop.
Rack	A length of gear attached to the gate which is driven by the pinion gear.
Rail	The steel bar, fixed to the ground, along which the gate runs.
Receiver	Receives a signal from a Remote (transmitter) and triggers the operator.
Remote	A hand held device which transmits a signal to trigger the operator.
Safety Beams	Also know as Infrared Beams or Passive Infrared Beams. These are safety devices that are mounted across the driveway and used to sense an obstruction to prevent the gate closing on the object resulting in damage or injury.
Test Button	Pressing the Joystick on the controller will trigger the operator.
Theft Deterrent Bracket	Deters the theft of and tampering with the operator.
Transformer	Reduces the power supply (220V AC/240V AC) to 16V AC or 24V AC to charge the battery.
Transmitter	See remote

TECHNICAL SPECIFICATIONS

CONTROLLER SYSTEM

Dual Processor	Main - ARM core - 90 DMIPS Supply - Microchip - 8 MIPS
Supply	Intelligent multi stage dual switch mode 3.5V, 5V, 7V, 13 - 29.4V
Motor Drive	Single / Dual H-Bridge 56 Amp
Inputs	INF/CLS, INF/OPN, LOCK, TRIG, PED, LOOP, LIGHT, TAMPER, REV1, MARKER1, GSM
Outputs	LIGHT, LOCK, ALARM, PULSE, STATUS, MOTOR
Display	8192 pixels (128 x 64)
Audio	16 Ohm 0.25W speaker with English voice prompts and warning messages.
Navigation	Joystick - 5 way
File System	FAT (USB interface)
Menu System	Graphical Interface with familiar icon navigation

SUPPLY SYSTEM

Transformer Input Voltage	110V-120V or 220V-240V AC +/- 10%, 50-60Hz (Input voltage is region dependant)
Controller Input Voltage	12V - 24V AC or 17V - 44V DC
Motor Voltage	12V - 24V DC
Motor Supply	Battery (12 / 24V) or Transformer driven
Battery Charger	Intelligent multi stage charger with automatic shutdown, current limiting and power save mode. 12V / 24V auto detect 12V Boost cycle up to 2A @ 14.7V 24V Boost cycle up to 0.8A @ 29.4V
Peak Power Consumption	37.4W (156mA @ 240V)
Typical Power Consumption	Less than 1.7W (7mA @ 240V)
Current Consumption (motor at rated load)	Up to 20A

COLLISION DETECTION AND PREVENTION

Multistage Electronic Collision Detection	Current, Motion and Supply Sensing
Current Sensing	4 Channels 5 stages each
Motion Sensing	2 Channels 5 stages each (Including dynamic sensing and profiling)
Supply Sensing	1 Channel
Infrared Safety Devices	Open & close infrared inputs
Beam Self Test	On compatible devices
Loop Detection	Yes
Anti-Crush Zone	Yes
Multi User Mode	Yes

Continues.....

.....continued

SECURITY FEATURES	
Alarm Inputs	Securi-Lock gate forced alarm, Ambush alarm, Break in alarm, Tamper alarm, Gate open alarm
Alarm Outputs	Open Collector (200mA)
Lock	Electric or Magnetic
Light	Courtesy and Warning
GATE	
Gate Mass	600kg (maximum)
Gate Speed	55 m/min (maximum)
Push Force	270 N (maximum)
Manual Override	Lockable door with thumb wheel
Maximum Operations per day	150 (gate mass and battery dependant) >1000 (when transformer driven)
RECEIVER	
Onboard Receiver Type	66 bit rolling code (DuraCrypt)
Channels	15
Storage Capacity	1024 devices

TERMS & CONDITIONS

These Terms and Conditions must be read carefully as, by commissioning the product, the user does acknowledge full acceptance thereof.

- All DACE products are products of convenience only and are not deemed to be security devices. While it might be possible to connect some products to an alarm system, these products may never be relied on as the primary intrusion detection/prevention device.
- It is the user's responsibility to ensure that the gate has closed properly and is in good working order before leaving the premises.
- The automation of each gate varies slightly. While DACE has tried to select the most commonly used settings as the default settings on the controller, your specific installation may need setting adjustment to function at its optimum.
- In the event of a DACE product malfunctioning, DACE will under no circumstances be held responsible for compromising the site's security.
- All DACE operators must be fitted with safety beams or edges. If the user elects not to install these safety devices, they acknowledge that there is a high risk of the gate or door closing on an object, person or animal. In some countries it is a legal requirement for safety beams to be fitted.
- DACE will not be held responsible for any damage, injury or death caused by an operator closing a gate onto an object, animal or person.
- It is the responsibility of the user to ensure that the gate is stationary prior to passing through it.
- It is the user's responsibility to ensure that there are no objects, animals or people that could be damaged or injured near the gate prior to operating it.
- The user must, at all times, be aware of objects, animals or people near the gate while it is moving and be ready to stop the gate in the event of an emergency.
- It is the user's responsibility to ensure that the product always has the latest software installed that might affect the operator's safe operation.
- It is the user's responsibility to test the operators external and internal safety devices and sensors from time to time to ensure that all is in good working order.
- The user is aware that a gate is a heavy piece of equipment and, by automating it, it highly increases the risk that it could cause damage, injury or even death. Regardless of the fact that DACE has tried its utmost in reducing these risks, they will always remain. As such, the user and owner accepts all liability regarding these risks and endeavours to make any person using the operator aware of these risks.

NOTES

Recommendations of notes that should be kept:

- » Groups - group number and group members
- » Time Manager slots - Time Period and Exclusion Period numbers
- » Remote users and the respective remote number (label the remotes)
- » Remote button numbers and the functions assigned to each (see pg. 30)
- » Cell phone 'User' numbers (see GSM Settings on pg. 35)
- » Cell & PUK numbers associated to the operator's SIM card
- » Date of last service to the operator
- » Your gate contractor's details
- » Record location of the controller's backup file.

Attach a copy of the invoice to this manual.

WARRANTY

DACE warrants that Ultima operators will be free from defects in material and workmanship for a period of 24 months of operation. Where operational data is not available, the warranty claim must be accompanied by the original invoice. In the event that both operational data and the original invoice are not available the warranty will be deemed to have been in effect from the date of manufacture. This warranty only covers the gearbox and onboard controller, it excludes any other components that might have been supplied with the operator such as a transformer, battery or beams (warranty information regarding components may be found in the installation guide pertaining to each component). This warranty explicitly only covers the repair, components and labour carried out at DACE, all other costs will be for the account of the purchaser.

This warranty does not apply if:

- the operator was subjected to misuse,
- the operator was installed contrary to the specifications provided in this manual,
- any attempt has been made to repair the goods by any workshop and/or person not authorised to do so by DACE or
- if goods have been repaired using components not tested, passed or authorised by DACE

This warranty does not cover:

- any Acts of God, including lightning, hail, water, power surge, insect damage, corrosion,
- the transport, or costs associated with the transport, of the defective product to a designated DACE repair centre,
- contractor or other third party costs
- any other costs that may have been incurred by the purchaser or any other party or
- on site repairs.

This warranty is a factory warranty, all goods will be repaired at the factory or one of the DACE designated repair centres.

In the case of international customers, the defective product must be returned to the supplier from where the product was purchased WITH PROOF OF PURCHASE FROM THAT SUPPLIER.

DISCLAIMER

Dura Access Control Equipment reserves the right to make changes to the products described in this manual without notice and without obligation to notify any persons or organisations of such revisions or changes. Additionally, DACE makes no representations or warranties with respect to this manual. This manual may only be copied or distributed as a whole, no alterations or subsections may be distributed or copied without the prior express consent of DACE in writing.



HEAD OFFICE: KwaZulu Natal, South Africa



+27 31 825 7484



info@dace.co.za



www.dace.co.za



facebook.com/DuraAccessControlEquipment