

TORTUGA AP90



FEATURES



COLORS



KEY FEATURES

- Maxi display volume
- Three different heights
- Perfect control of temperature all over the display volume
- Sliding double glazed door closure on the operator side
- LED lighting as standard
- Electronic control board

TORTUGA

Refrigerated ventilated showcase - positive temperature (+4°C) | The fixed front, the top and the side glasses are double glazed; 01 intermediate shelf with LED light and "Easy connect" system with electrified racks; operator side closed by double glazed sliding doors | Molded heat-insulated tank with rounded internal edges coated by AISI 304 s/s | Polish s/s display area | Ventilating refrigeration system on all shelves | Automatic defrost | Digital control panel | Nr.4 wheels | Tubular structure in painted s/s

CIAM
REFRIGERATION DESIGN

Distributed By
AG ADVANCED GOURMET
IN THE USA

TORTUGA AP90

SECTIONS AND MODELS

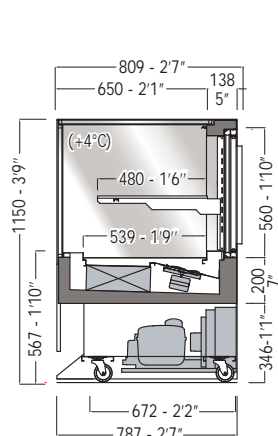

TORTUGA 1 PASTRY

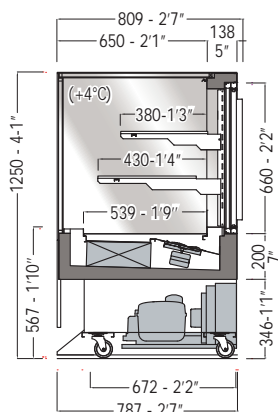

TORTUGA 2 PASTRY

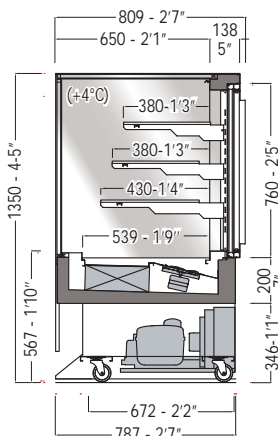

TORTUGA 3 PASTRY

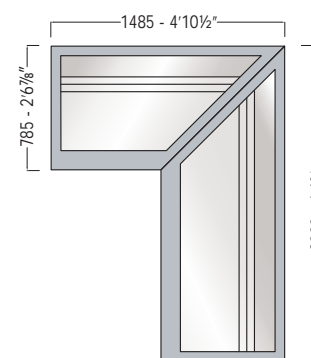

TORTUGA 1-2-3 PASTRY

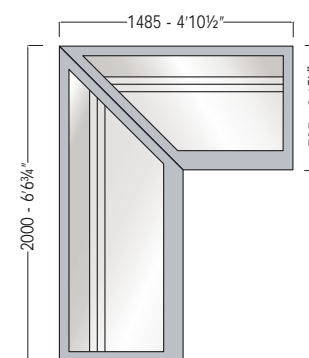

TECHNICAL FEATURE	
External dimensions (L-D-H)	inches mm
Crated dimensions (L-D-H)	inches mm
Refrigeration	Type
Refrig. display area	Type
Operating temp.	°C / °F
Compressor	nr./Type
Cooling power*	(W / Btu/h)
Electric supply	(V/ph/Hz)
Power consumption	(W/A)
Defrost	Mode/type
Climatic class	N°/°C (F°)/H.R.
Refrigerant Gas	Type
Net weight	Kg / Lb
Crated weight	Kg / Lb

TORTUGA 1
AP90
(78¾/58½) - 31⅞ - 45¼ (2000/1485)-809-1150
85⅞ - 66⅞ - 55⅞ 2180-1680-1420
Ventilated
Deck / Shelves
+4 / 39.2
1 / hermetic
1900 / 6500
230/1/50
1650 / 7,3
automatic
3/25(77)/60%
R452A
300 / 661
560 / 1234

TORTUGA 2
AP90
(78¾/58½) - 31⅞ - 49¼ (2000/1485)-809-1250
85⅞ - 66⅞ - 59⅞ 2180-1680-1520
Ventilated
Deck / Shelves
+4 / 39.2
1 / hermetic
2000 / 6830
230/1/50
1700 / 7,5
automatic
3/25(77)/60%
R452A
330 / 727
610 / 1344

TORTUGA 3
AP90
(78¾/58½) - 31⅞ - 53⅞ (2000/1485)-809-1350
85⅞ - 66⅞ - 63¾ 2180-1680-1620
Ventilated
Deck / Shelves
+4 / 39.2
1 / hermetic
2200 / 7510
230/1/50 (UE) 220/1/60 (USA)
1800 / 8,0
automatic
3/25(77)/60%
R452A
360 / 793
650 / 1433

STANDARD FEATURE

Ventilated refrigeration | Full volume temperature control | LED Lighting system | Double glazed walls | Sliding doors on the operator side | Electronic temperature control | Automatic evaporation system of condensate water | Castors

OPTIONAL

- Remote condensing unit

TORTUGA

* At -10°C / 14°F of expansion

The company reserves the right to make modifications to the products without prior notice.

CIAM s.p.a. | Viale dei Pini 9 | 06081 | Petignano di Assisi | PG - Italy | Tel: 0039 07580161
web: www.ciamweb.it | mail: info@ciamgroup.it

2017 / v1.0



CIAM
REFRIGERATION DESIGN

Distributed By
AG ADVANCED GOURMET
IN THE USA