

# VERTIGO PASTRY



## KEY FEATURES

- Ventilated refrigeration
- Chrome extra shining finiture
- Fluorescent lighting on each shelf
- Electronic control board
- Tempered front glass with safely tilt downs opening system

## FINISHING: WOODS / LAMINATES / OTHERS FINISHING

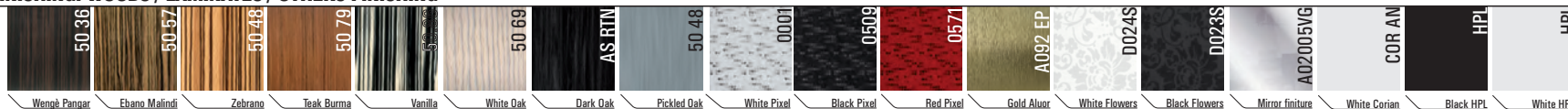

## COLORS



## FEATURES



Flexibility, Elegance and technology. Available in three different heights: VERTIGO 1 -total height cm117 – particularly suited for ice cream. VERTIGO 2 - total height cm 136 – the best solution for convenience store with diversified food offer. VERTIGO 3 - total height cm 150 - with three shelves fully illuminated. Enriched with extra shiny profiles which combined with the latest generation of LED lighting exalt the displayed products CIAM has at heart the safety of its customers and develops technical solutions to protect the health of the users of its products. Further configuration available: dry hot, bain-maire, gelato, bread and more.

# VERTIGO

**CIAM**  
REFRIGERATION DESIGN

Distributed By  
**AG** ADVANCED GOURMET  
IN THE USA

# VERTIGO PASTRY

## SECTIONS AND MODELS

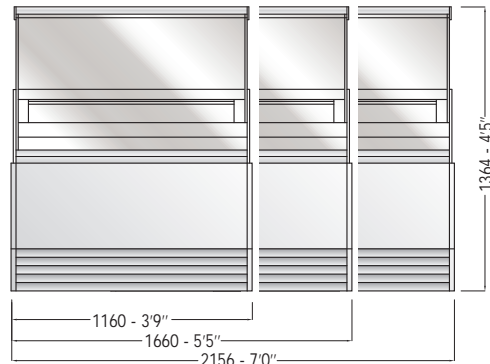
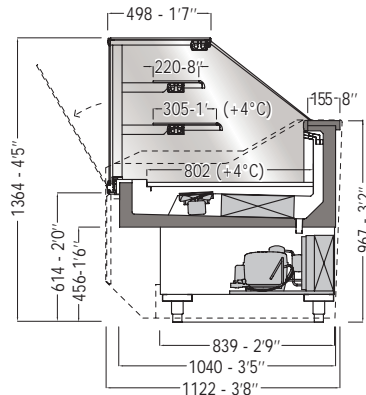

**VERTIGO 2 - PASTRY**

TECHNICAL FEATURE		VERSIONS				
		1110	1610	2106	30° Open Corner	30° Closed Corner
External dimensions (L-D-H)	inches mm	43 <sup>2</sup> / <sub>3</sub> " - 44 <sup>1</sup> / <sub>8</sub> " - 53 <sup>2</sup> / <sub>3</sub> " 1160-1122-1364	65 <sup>1</sup> / <sub>3</sub> " - 44 <sup>1</sup> / <sub>8</sub> " - 53 <sup>2</sup> / <sub>3</sub> " 1660-1122-1364	84 <sup>7</sup> / <sub>8</sub> " - 44 <sup>1</sup> / <sub>8</sub> " - 53 <sup>2</sup> / <sub>3</sub> " 2156-1122-1364	62" - 44 <sup>1</sup> / <sub>8</sub> " - 53 <sup>2</sup> / <sub>3</sub> " 1574-1122-1364	62" - 44 <sup>1</sup> / <sub>8</sub> " - 53 <sup>2</sup> / <sub>3</sub> " 1574-1122-1364
Crated dimensions (L-D-H)	inches mm	52" - 52" - 63 <sup>3</sup> / <sub>4</sub> " 1320-1320-1620	71 <sup>5</sup> / <sub>8</sub> " - 52" - 63 <sup>3</sup> / <sub>4</sub> " 1820-1320-1620	91 <sup>1</sup> / <sub>3</sub> " - 52" - 63 <sup>3</sup> / <sub>4</sub> " 2320-1320-1620	70 <sup>7</sup> / <sub>8</sub> " - 52" - 63 <sup>3</sup> / <sub>4</sub> " 1800-1320-1620	70 <sup>7</sup> / <sub>8</sub> " - 52" - 63 <sup>3</sup> / <sub>4</sub> " 1800-1320-1620
Refrigeration	Type	Fan Ventilated	Fan Ventilated	Fan Ventilated	Fan Ventilated	Fan Ventilated
Refrigerated display area	Type	Deck / Shelves	Deck / Shelves	Deck / Shelves	Deck / Shelves	Deck / Shelves
Operating temperature	°C / °F	+4 / 39.2	+4 / 39.2	+4 / 39.2	+4 / 39.2	+4 / 39.2
Compressor	nr. / Type	1 / hermetic	1 / hermetic	1 / hermetic	1 / hermetic	1 / hermetic
Cooling power *	(W)	820	1030	1290	1100	1010
Electric supply	(V/ph/Hz)	230/1/50 (UE) 120/1/60 (USA)	230/1/50 (UE) 120/1/60 (USA)	230/1/50 (UE) 120/1/60 (USA)	230/1/50 (UE) 120/1/60 (USA)	230/1/50 (UE) 120/1/60 (USA)
Power consumption	(W/A)	1085/8,2	1190/8,0	1490/9,0	1170/8,0	1140/8,0
Defrost	Mode / type	electric	electric	electric	electric	electric
Climatic class	N°/°C(F°)/H.R.	4+/35 (95)/70%	4+/35 (95)/70%	4+/35 (95)/70%	4+/35 (95)/70%	4+/35 (95)/70%
Refrigerant Gas	Type	R452A	R452A	R452A	R452A	R452A
Net weight	Kg / Lb	205 / 650	275 / 606	340 / 749	250 / 551	250 / 551
Crated weight	Kg / Lb	315 / 694	425 / 936	530 / 1168	400 / 881	400 / 881

### STANDARD FEATURE

- Chrome finishing
- Fluorescent light on each shelf
- Electric control board
- Electric defrost
- Front glass with safely tilt down opening system

### OPTIONAL

- LED lighting
- Castors
- Extra clear glass
- Remote condensing unit
- Condensate water tray with electric evaporation

\* At -10°C of expansion

The company reserves the right to make modifications to the products without prior notice.

CIAM s.p.a. | Viale dei Pini 9 | 06081 | Petignano di Assisi | PG - Italy | Tel: 0039 07580161  
web: [www.ciamweb.it](http://www.ciamweb.it) | mail: [info@ciamgroup.it](mailto:info@ciamgroup.it)

2017 / v1.0

# VERTIGO



**CIAM**  
REFRIGERATION DESIGN

Distributed By  
**AG** ADVANCED GOURMET  
IN THE USA