

BAYLISS XL AUTOVENT

Dear Customer,

It can be a temptation to disregard instructions, but we urge you to spend a few moments reading these to make fitting your Autovent much easier. If you are pleased with your Bayliss Autovent, please tell others. If not, please tell us.

Preparing the unit for fitting

1. Remove the Autovent unit and fixings pack from the box.
2. Prior to fitting the Autovent, the powertube has to be cooled by placing it in a refrigerator for approximately 30 minutes. This can be accomplished by either placing the complete Autovent in the refrigerator, or by removing the powertube and cooling it separately. Removal of the spring clip releases the power tube (See Fig 5, Detail A).
3. When the powertube is cool, remove from the refrigerator and place the steel piston rod (See Fig 5), against a hard surface and push it firmly back into the powertube. If the powertube has been detached from the Autovent, it should be refitted by reversing the removal process. The Autovent is now ready to fit.
4. Because the design of greenhouse vents varies considerably, it is impossible to illustrate every type of fitting. Choose the fitting method most suitable from those shown in Fig 3 and Fig 4. However, there may be some designs to which these are not easily applicable. In these instances please contact the manufacturer for advice.

The Autovent should be fixed as near as possible to the middle of the vent so that it will not twist. See Fig 1.

To ensure that the Autovent is not overloaded and that headroom or growing space is not reduced, **IT IS MOST IMPORTANT** that the gap between the straight link and the glass in the vent is the same at both ends when the vent is closed. See Fig 2.

Setting

5. When the Autovent has been fitted, lift the vent wide open with one hand and slip the threaded steel piston rod into the brass knurled adjuster which is fixed in the swivelling block. See Fig 5. Screw the knurled adjuster until the Autovent unit holds the window open 1/8 inch (3mm). Setting is best carried out when there is no wind blowing through the window and when the temperature measured by a thermometer placed or hung by the Autovent unit indicates the temperature at which you wish the vent to start opening. If you wish the Autovent to start opening at a higher temperature, turn the knurled adjuster clockwise (i.e. in the direction of the arrow in Fig 5) and vice versa if a lower temperature is required.

Fig 5

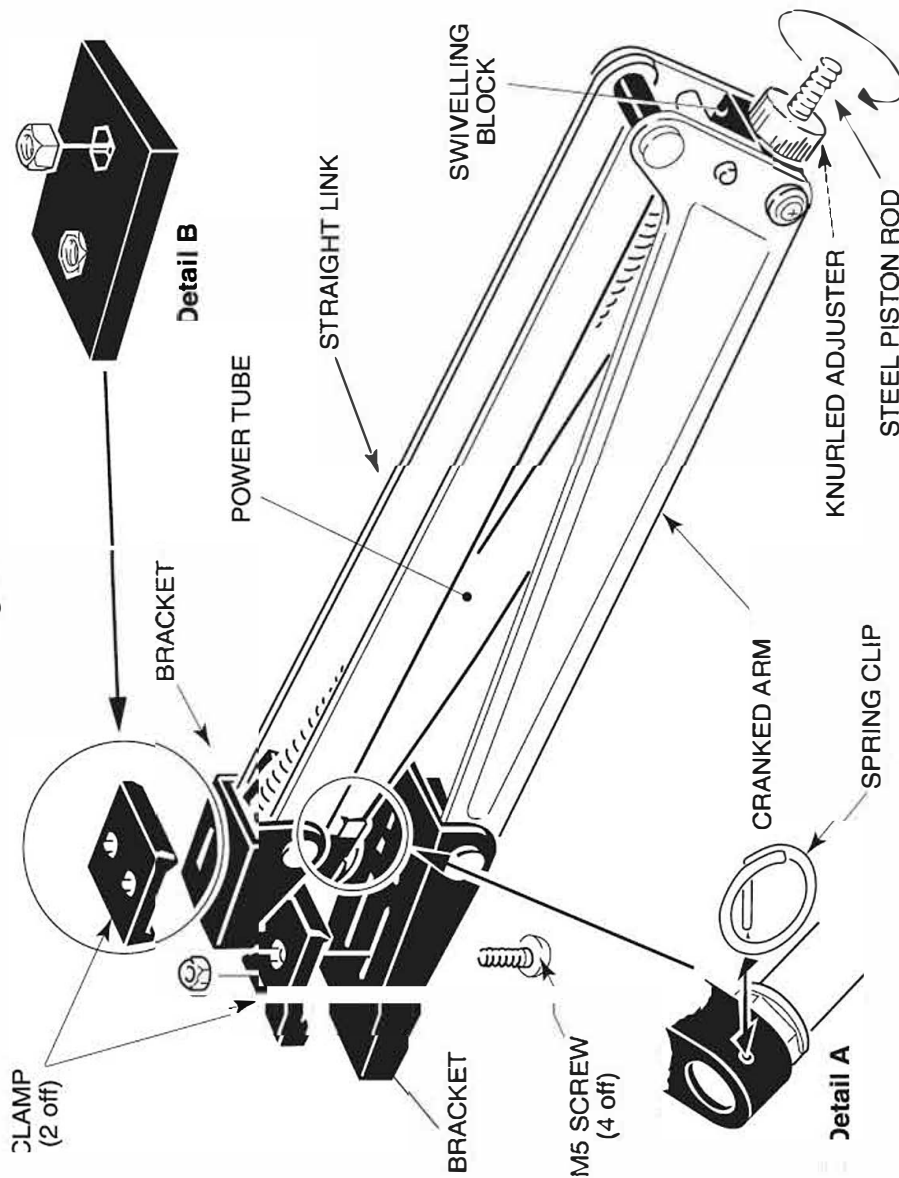

Other Information

The XL Autovent is designed in such a way that it will not open in cold or windy weather. It is fitted with a strong spring to hold it steady, but in high winds other windows and doors should be kept closed.

The XL Autovent should not be harmed by low temperatures and can be left on the window throughout the year.

If there is an existing vent stay, this should be removed or fastened in such a way that it cannot stop the Autovent unit from working.

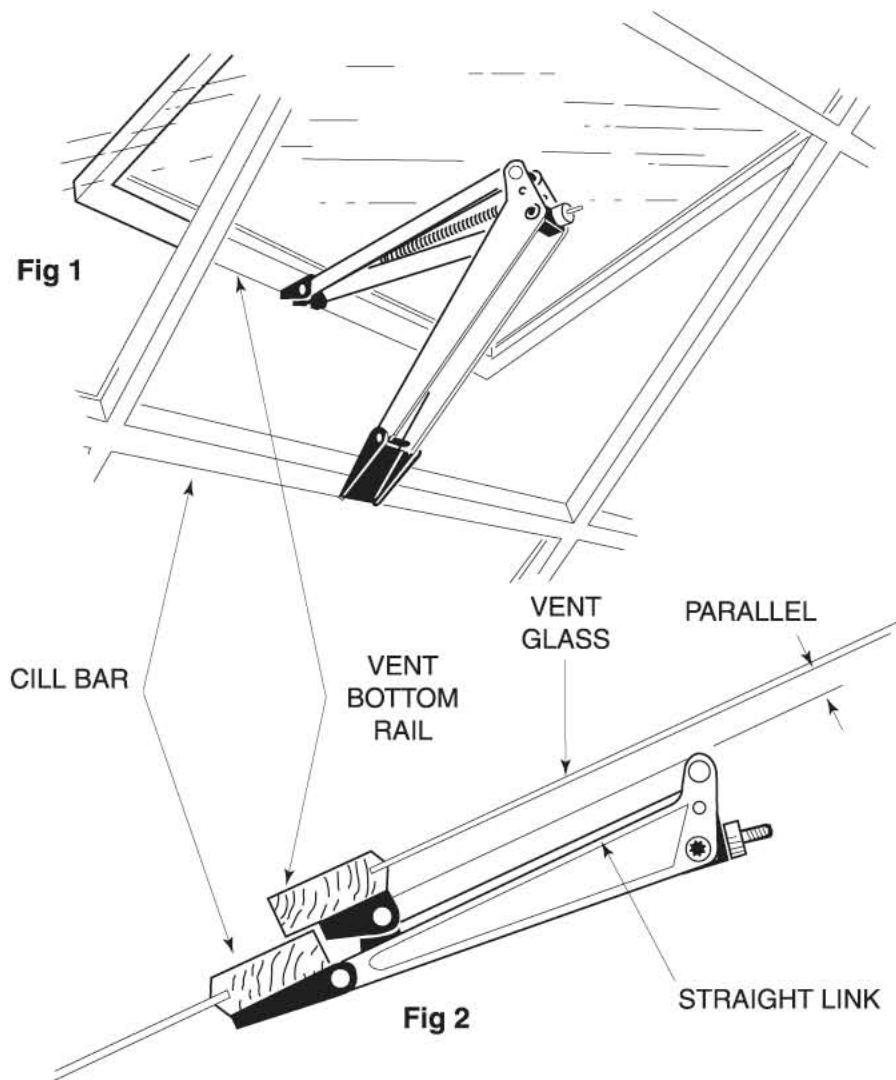

Fig 3 Aluminium framed greenhouse

The screw pack contains 4 Posidriv 2BA metal screws, 4 nuts and two clamps which can be used for fitting the XL Autovent to aluminium framed greenhouses. The illustration shows how this may be done. Look carefully at the clamps prior to fitting, making sure that the 'V' shaped ridges are biting into the greenhouse frame and the square edged ridges are against the Autovent brackets. Ensure the nuts are located in the clamps prior to fitment (see Fig 5, Detail B). The strongest fixing is obtained when the screws fit closely against the edge of the cill bar and the bottom rail.

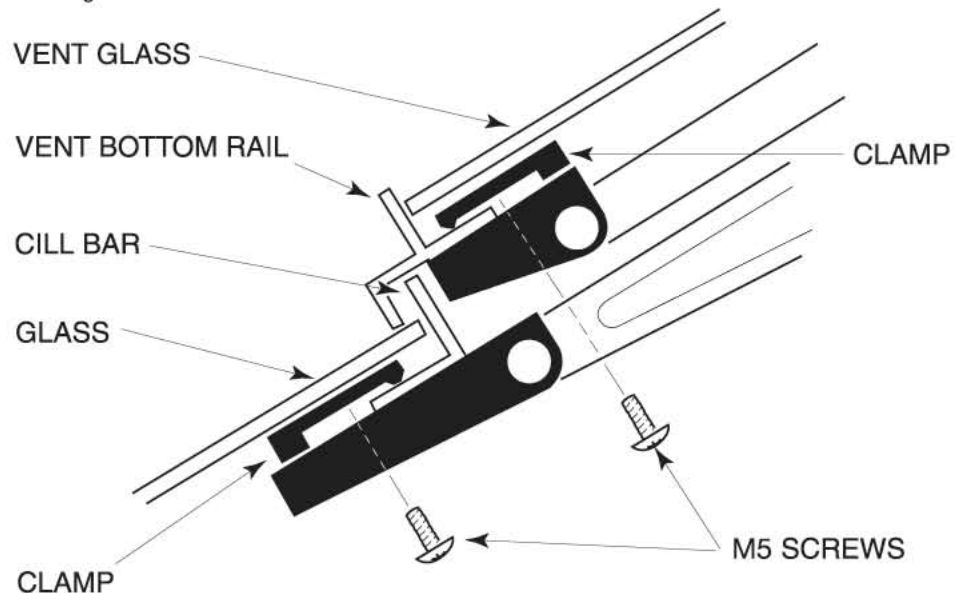

Fig 4 Wood framed greenhouse

The screw pack contains 4 Posidriv woodscrews which are used for fitting the XL Autovent to a timber framed greenhouse. The illustration shows how this may be done.

