

EASY ACCESS COLD FRAME BENCH R10 (02)

Assembly Instructions

COMPONENTS

TOP FRAME	COMPONENT LENGTH	QTY
A Length Piece	1194mm	2
B Width Piece	632mm	2
C Corner Leg	759mm	4
D Cross Piece	574mm	1
E Cross Piece Bracket	50mm	2
LOWER BRACING		
F Length Piece Back	1074mm	1
G Length Piece Mid	1120mm	1
H Cross Piece	515mm	2
I Mid Support 'T'	280mm	1
Top Plates	592mm x 620mm	2
Lower Plates	560mm x 280mm	2
Bolts & Nuts		66

CROSS SECTIONS

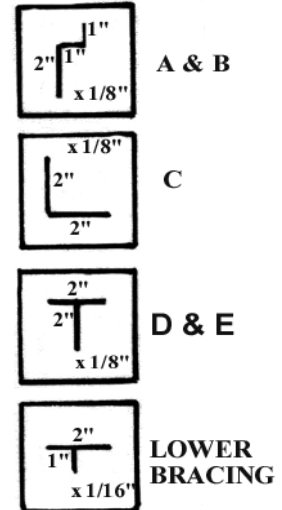

PLEASE NOTE assemble the whole unit with bolts and nuts fingertight only. When complete square up and tighten.

1. Please check the components.
2. Bolt corner legs to width piece 'B' at the top of the legs and the lower holes. Join the two end sections using length piece 'A'. The cross piece is connected to the inside of both 'A's using the 2" brackets.
3. Bolt the lower back brace between the two back legs. The lower mid brace bolts to the lower end braced 'H'. The mid support rests between 'F' and 'G'.
4. Lower Plates into framework.

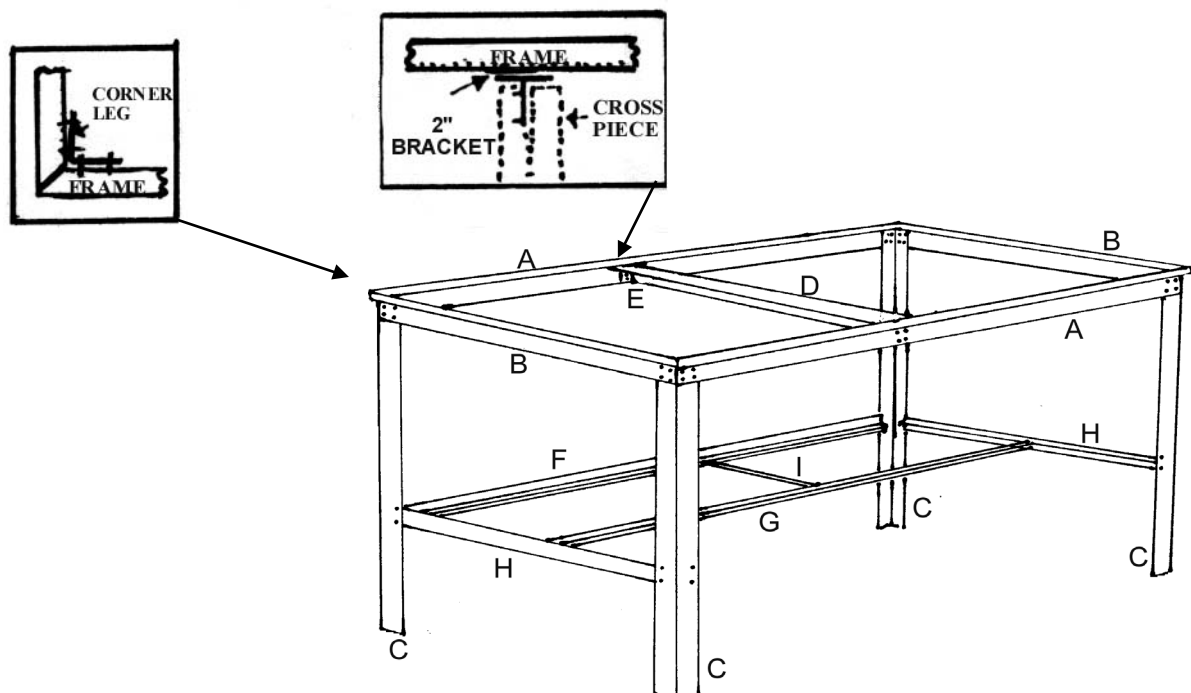

Two Wests & Elliott Ltd.

Unit 4, Carrwood Road, Sheepbridge Industrial Estate, Chesterfield S41 9RH (01246) 451077