

Wooden growhouse

Before You Start

Please check that all components are present and read through these instructions carefully.

Assembly

1. Check all screws are tight in the ready-made frame sections but avoid over-tightening.
2. Do not yet remove the protective covers on the polycarbonate glazing: note the cover is on the outside of the panels.
3. Assemble the back and side frames, and front braces (parts **A**, **C1**, **C2** & **C3**) using the large screws (**H**) and the pre-drilled holes in the frame (See Fig 1).
4. Fix the base plates (**G**) on the underside of two corners as required using screws (**J**).
5. Add the shelves (**K**) to the shelf supports.
6. Place the lid (**B**) in position so that the hinges are at the back and are facing downwards. Line up the lid with the frame sides and hold firmly whilst attaching the hinges to the back panel (**A**) using screws (**I**) (see Fig 3).
7. To assemble the lid support arms:
 - a. Pass the washers over bolts (**F**) and insert the bolts, from the outside, through the slots in the support arms and into the pre-drilled holes in the sides (**C**). Screw in part way to secure them (see Fig 5).
 - b. The wing bolt can be tightened when the lid is in the required position.
8. Attach the doors (**D**) in the same way as the lid in point 6 above, lining up the doors with the frame and attaching with screws (**I**) (see Fig 5).
9. To complete the assembly, peel off the protective sheet from the polycarbonate panels and site the Growhouse in good light but out of prolonged fierce sunlight. Use the corner base plates to peg or bolt down the Growhouse if extra security is required.

Care & maintenance

- Extra coatings of wood preservative will prolong the life of the product but be sure to use one that is harmless to plants.
- Avoid constant contact with wet soil by mounting the frame on bricks, slabs or wooden battens.

Helpline Number

If you have any problems or queries with this product please call our helpline on +44 (0)1406 372227 between the hours of 9am to 5.30pm Monday to Friday.

Parts & Fittings Supplied

Ref	Description	Illustration	Qty
A	Glazed Back Panel		1
B	Glazed Lid with Hinges		1
C1	Glazed Side Panel Left		1
C2	Glazed Side Panel Right		1
C3	Front Cross Braces		2
D	Glazed Door With Hinges		2
K	Slatted Shelf		2
E	Lid Support Arms (fitted)		2
F	35mm Wing Bolt and Washer		2
G	Base Plates		2
H	Large Frame Screws		14
I	Small Screws		12
P	Door Top Latch (fitted)		1
J	Base Plate Screws		8



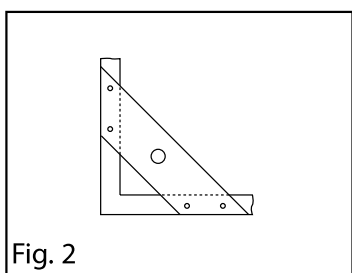
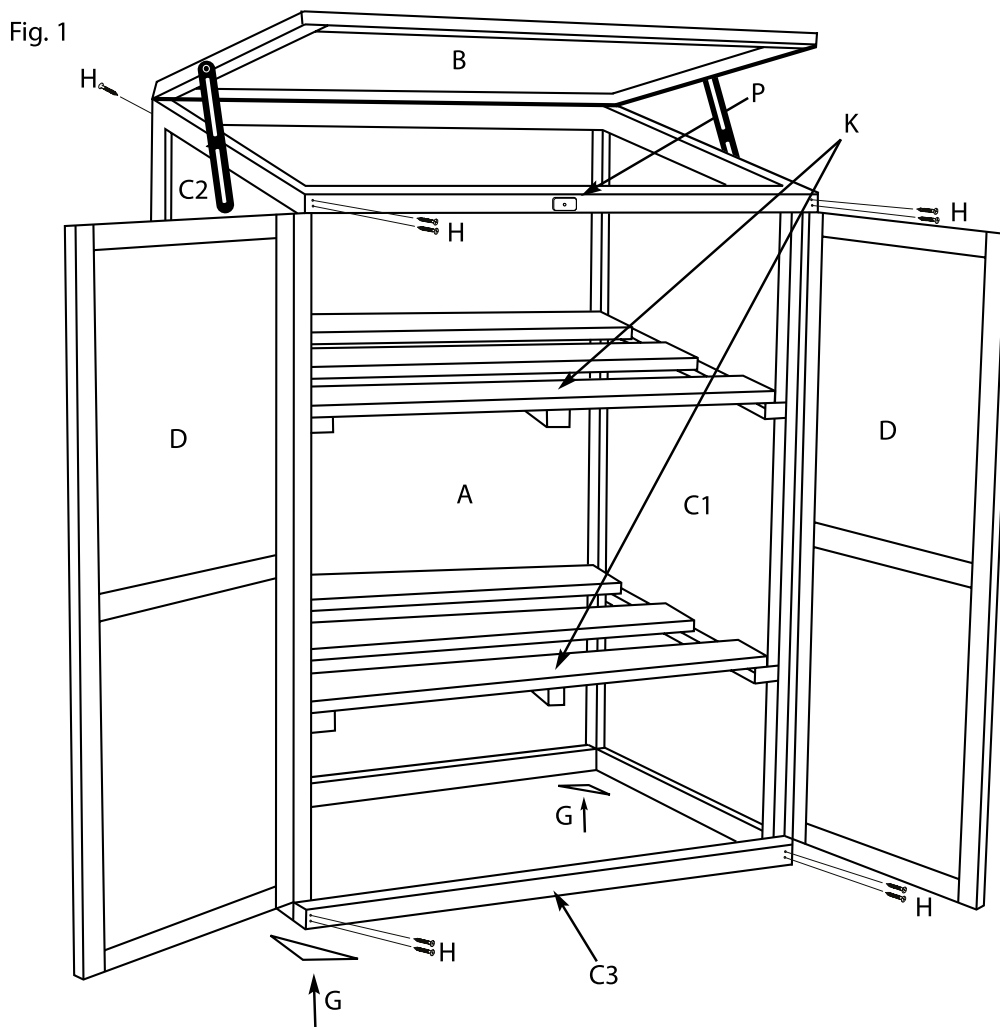

Fig. 2

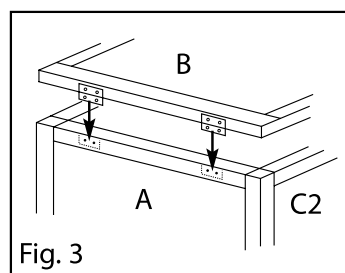

Fig. 3

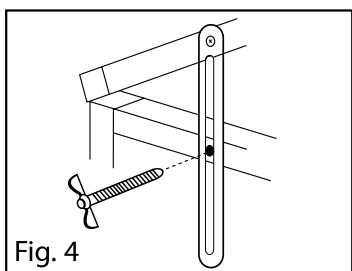

Fig. 4

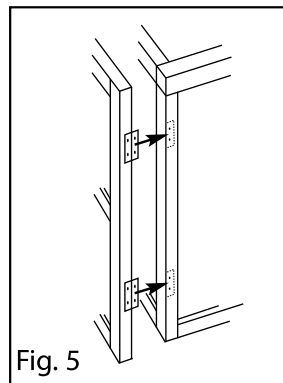

Fig. 5