

MODULAR PLANTER INSTRUCTIONS

We recommend using the following tools (not supplied):

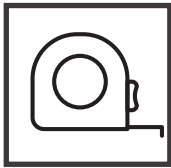

Tape Measure



Pozidrive
Screwdriver

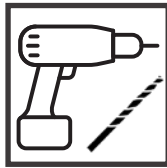

Drill & 2-3mm
Drill Bits

FIXING PACK CONTAINS:
FIXING PACK CODE: MODPLANTFP

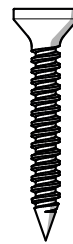

4 x 50mm Screws
QTY: 22

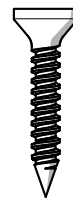

3.5 x 30mm Screws
QTY: 8

PLEASE KEEP PLASTIC BAGS AND SMALL PARTS AWAY FROM CHILDREN

CHECK AND TIGHTEN ALL THE FIXINGS APPLIED TO THIS PRODUCT ON A REGULAR BASIS.

1

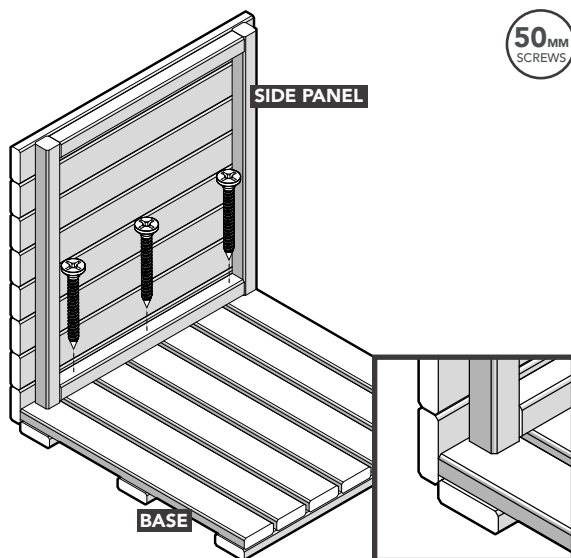

Position the Base in your desired location. **Position and secure the Side Panel to the Base.** Ensure the edge is flush to the Base as shown above.

2

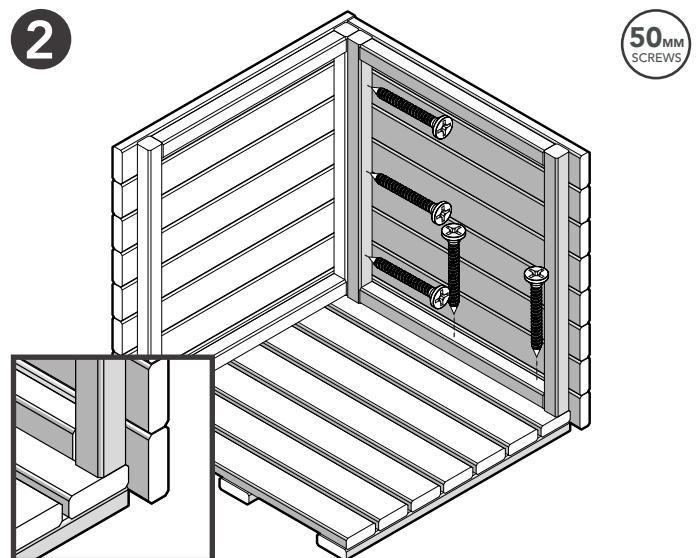

Position and secure the next Side Panel. Butt the Side Panel up against the first Side Panel and ensure the batten is flush to the Base as shown above.



IMPORTANT
Assembly requires 2+ adults.



REMINDER
Always pre-drill before screwing.

Missing something or need more information?
Call our aftersales team on
0333 321 3142

Visit our website for spare instructions and more information
www.forestgarden.co.uk

3

50MM
SCREWS

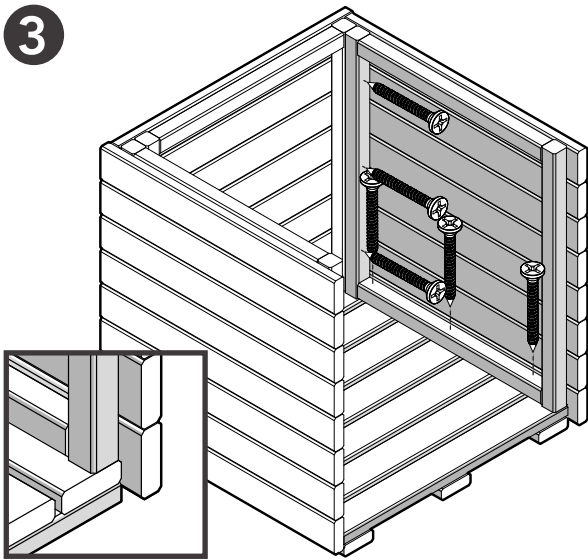

Position and secure the next Side Panel. Butt the Side Panel up against the second Side Panel and ensure the batten is flush to the Base as shown above.

4

50MM
SCREWS

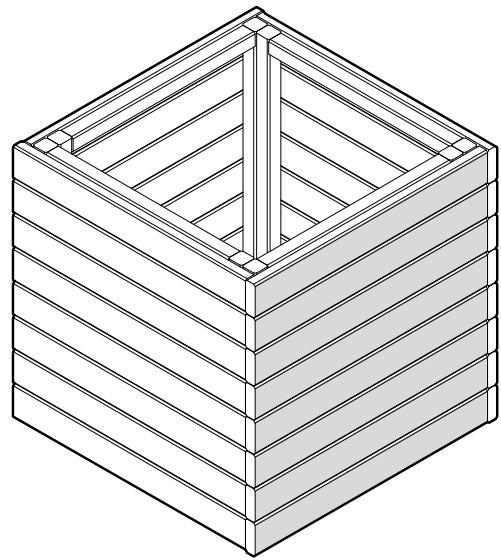

Position and secure the final Side Panel. Ensure the edge of the panel is flush to the first Side panel and is completely square as shown above.

5

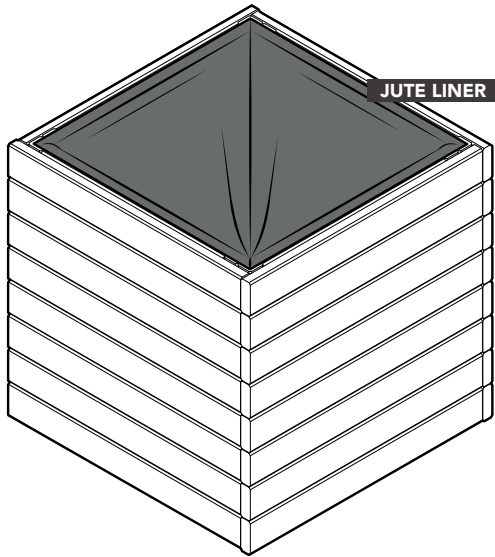

Lay out and position the Jute Liner material inside your planter. Overlap over the top edge and use the Surrounds to hold in place.

30MM
SCREWS

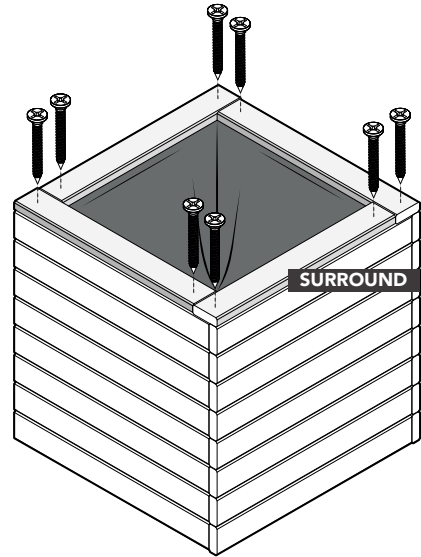

Secure the Surrounds to the Side Panels. Ensure the Jute Liner is held in position when screwing the Surrounds in place.

HEALTH & SAFETY

We strongly recommend that PPE (Personal Protective Equipment) is used throughout your build to ensure you are protected from any potential health and safety risks. **Do not exempt yourself from wearing PPE.**



CHECK YOU HAVE ALL YOUR PARTS PRIOR TO ASSEMBLY.

(The parts do not have codes on them. They are listed below should you need to order one.)

Timber is a natural material of which will shrink and swell as a result of varying moisture content.

Assembly of damaged parts may be deemed to be acceptance and this may affect the remedies you are entitled to. If the product is not constructed in accordance with the instructions, or is altered in anyway (e.g. painted), the manufacturer cannot be held liable for any resulting damage.

The components provided may be heavy. Please lift with caution and with a minimum of 2 people.

Modular Planter (MODPLANT)			
Label	Part Code	Description	No.
A	MODPLANTBASE	Base 460x460mm	1
B	MODPLANTSIDE	Side Panel 480x487mm	4
C	JLINER500	Jute Liner	1
D	60200440PPT	Surround 60x20x440mm	4

Use the labelled components to help identify the part code and description.

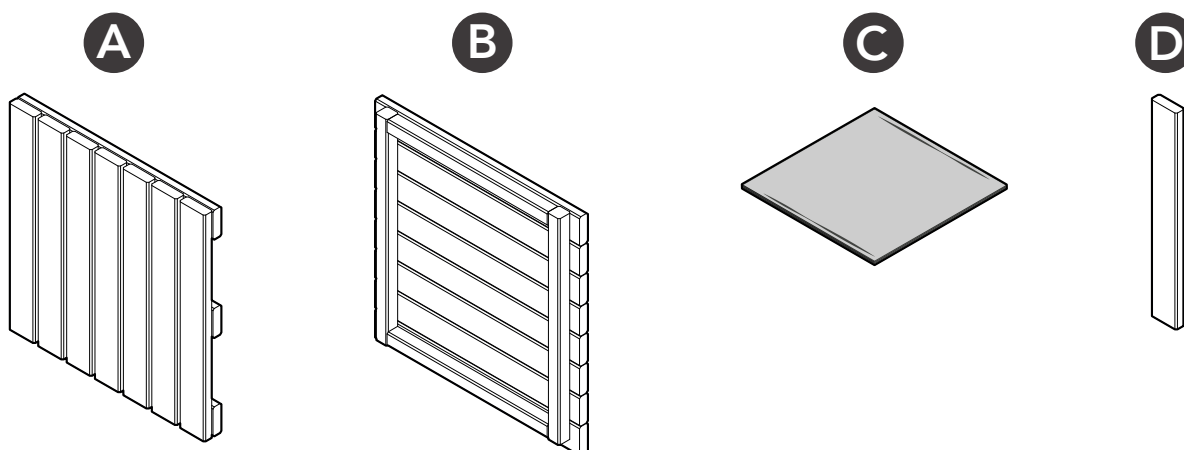

TREATED TIMBER CONTAINING A BIOCIDAL PRODUCT CONTROL OF WOOD DESTROYING ORGANISMS

Active Ingredients - Propiconazole, Tebuconazole, IPBC, Permethrine, Benzyl-C12-16-Alkyldimethyl Chlorides. (Dip Treated)
Basic Copper Carbonate, DDA Carbonate, DDA Chloride. (Pressure Treated)

Wear gloves when handling. Avoid inhalation of sawdust. Do not use in contact with drinking water or food. Do not use for animal bedding or in fish ponds. Dispose of treated wood responsibly.