

more Power Features

new POWER

Now available in:
1200 watts 20 kHz
2200 watts 20 kHz
2500 watts 15 kHz
3500 watts 20 kHz

new FEATURES

- Digital Amplitude Control
- Ultrasonic Horn/Stack Frequency Display
- Good Part/Bad Part Output Signal
- 30% smaller power supply footprint

new MODELS

WELD BY:

digital time
- **Model GXT**

digital time and/
or constant energy
- **Model GXE**

digital time, constant
energy and/or distance
- **Model GXL**

STANDARD FEATURES INCLUDE:

- Automatic Frequency Tuning
- Multiple Job Storage
- Digital Force Triggering
- Calibration Pulse Prior to Every Weld Cycle
- Back-Lit LCD Display
- Ultrasonics Load Meter Scale
- Upper and Lower Weld Limit Settings
- Optional RS232 Serial Port Printer Output
- Optional PLC I/O (Input/Output) Ports
- Soft Start Overload Protection Circuitry
- Load Regulation Circuitry



SONICS[®]
SONICS & MATERIALS, INC.



Model 2055 Press

Model 2055/1555 20 kHz and 15 kHz ultrasonic plastics welding systems



GX-Series Power Supply**

Leaders in the field of ultrasonic plastics welding equipment and technology since 1969, Sonics & Materials offers its new line of **GX-Series** ultrasonic power supplies, combined with the super-rigid Model 2055 and 1555 presses, to create a powerful new system designed to handle even the most demanding applications.

The new GX-Series provides microprocessor control and consistent reliability for every application, and delivers more output power to the Model 2055 and 1555 presses, easily handling significantly larger part size and force requirements. Power supplies feature smart-logic, user-friendly navigation and are available in three different welding mode configurations for maximum versatility and flexibility.

Power Supply**

Dimensions: 15.25" W x 6.50" H x 18.75" D (387.3 x 165.1 x 476.25 mm)

Weight: 21 lbs. (9.5 kg)

**Power supply for 3500 watt system is larger and heavier. Call for more information.

Innovating
since

1969

dimensional data

All Dimensions: Inches (mm)

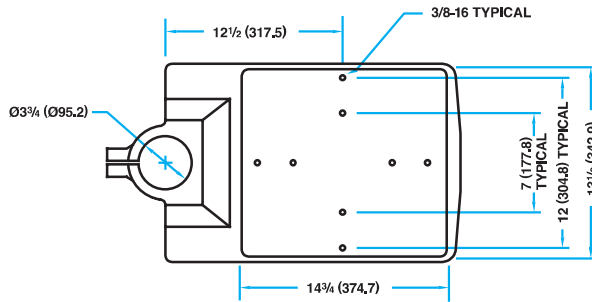
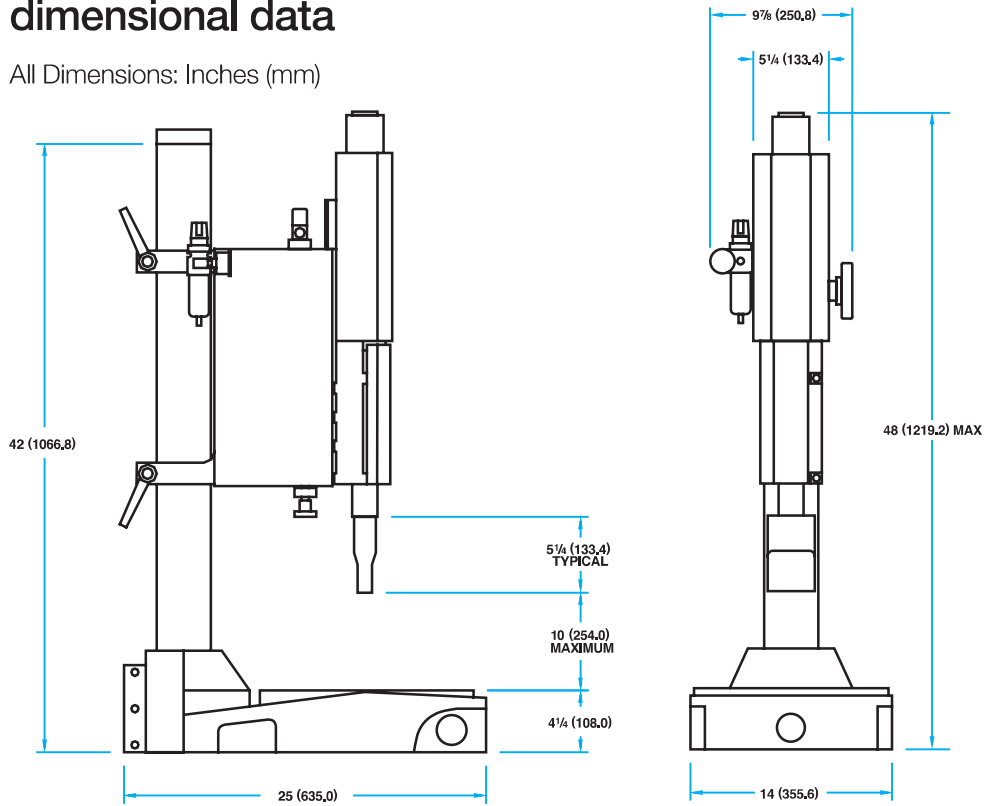

OPTIONAL STAND-ALONE HUB

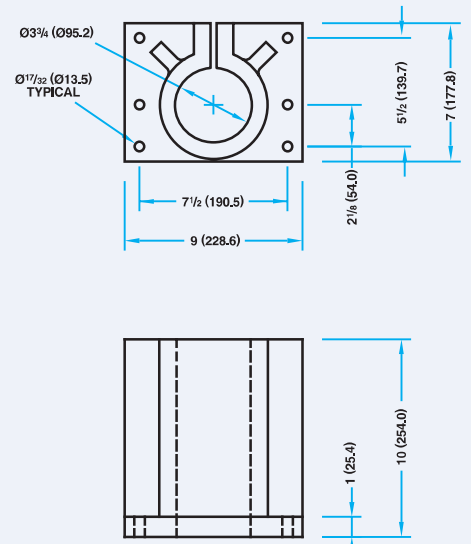

model 2055 and 1555 features

- Single Piece Rigid Cast Aluminum Machine Base and Column Hub
- Increased Steel Column Diameter and Wall Thickness
- Single Rail Linear Slide
- Direct In-Line Air Cylinder
- Extended Center Base to Column Throat Depth Distance
- Additional 12" Center-to-Center Lower Fixture Mount Holes

specifications, additional features, and options

Dual Cycle Start Buttons	Standard
Non-Contact Cycle Start Buttons	Optional
Front Emergency Stop	Standard
Head Adjust Counter	
Balance Spring	Standard
Adjustable Positive Stop	Standard
Automation Limit Switches	Optional
360° Snap-In Stack Assembly	Standard
Rigid Mount Booster	Optional
Stand Alone Column Hub	Optional
Extended Length Column	Optional
3.75" (95.3) Column Diameter	Standard
4" (101.6) Stroke Air Cylinder	Standard
6" (152.4) Stroke Air Cylinder	Optional
Air Cylinder Bore Diameter	2.5" (63.5)
Clamping Force at 90 PSIG	441 lbs. (1961n)
Input Voltage	220 VAC
Weight	165 lbs. / 74.8 kg

