

more Power Features

new POWER

Now available in:
400 watts
800 watts

new FEATURES

- Digital Amplitude Control
- Ultrasonic Horn/Stack Frequency Display
- Good Part/Bad Part Output Signal
- 30% smaller power supply footprint

new MODELS

WELD BY:

digital time
- **Model GXT**

digital time and/
or constant energy
- **Model GXE**

digital time, constant
energy and/or distance
- **Model GXL***

STANDARD FEATURES INCLUDE:

- Automatic Frequency Tuning
- Multiple Job Storage
- Digital Force Triggering
- Calibration Pulse Prior to Every Weld Cycle
- Back-Lit LCD Display
- Ultrasonics Load Meter Scale
- Upper and Lower Weld Limit Settings
- RS232 Serial Port Printer Output
- Optional PLC I/O (Input/Output) Port
- Soft Start Overload Protection Circuitry
- Load Regulation Circuitry
- Distance Mode Settings in English or Metric Units*

*requires optional linear encoder



SONICS[®]
SONICS & MATERIALS, INC.



Model 4095 Press

Model 4095 40 kHz ultrasonic plastics welding system



GX-Series Power Supply

Leaders in the field of ultrasonic plastics welding equipment and technology since 1969, Sonics & Materials offers its new line of **GX-Series** ultrasonic power supplies, combined with the model 4095 press, to provide a fast, precise process for delicate assemblies that require mild ultrasonic horn vibrations.

The new GX-Series, available in 400 and 800 watts power, provides microprocessor control and consistent reliability for every application. Power supplies feature smart-logic, user-friendly navigation and are available in three different welding mode configurations for maximum versatility and flexibility.

Power Supply

Dimensions: 15.25" W x 6.50" H x 18.75" D (387.3 x 165.1 x 476.3 mm)
Weight: 21 lbs. (9.5 kg)

Innovating
since

1969

dimensional data

All Dimensions: Inches (mm)

model 4095 features

- Rigid Cast Aluminum Base and Column Hub
- Single Rail Linear Slide
- Direct In-Line Air Cylinder
- Easy Access Pneumatic Pressure Control
- Easy Access Head Up and Down Pneumatic Speed Control
- Head Adjust Counter Balance Spring
- Linear Encoder for Distance Welding (optional)

specifications, additional features, and options

Head Adjust Counterbalance Spring	Standard
Dual Cycle Start Buttons	Standard
Non-Contact Cycle Start Buttons	Optional
Front Emergency Stop	Standard
Precision Air Regulator and Gauge	Optional
Adjustable Positive Stop	Standard
Automation Limit Switches	Optional
360° Snap-In Stack Assembly	Standard
Rigid Mount Booster	Optional
Stand Alone Column Hub	Optional
Extended Length Column	Optional
3.50" (88.9) Column Diameter	Standard
3.00" (76.2) Stroke Air Cylinder	Standard
Air Cylinder Bore Diameter	1.5" (38.1)
Clamping Force at 90 PSIG	161 lbs. (716n)
Input Voltage (standard)	220 VAC
Optional Input Voltage	120 VAC
Weight	126 lbs. / 57.2 kg

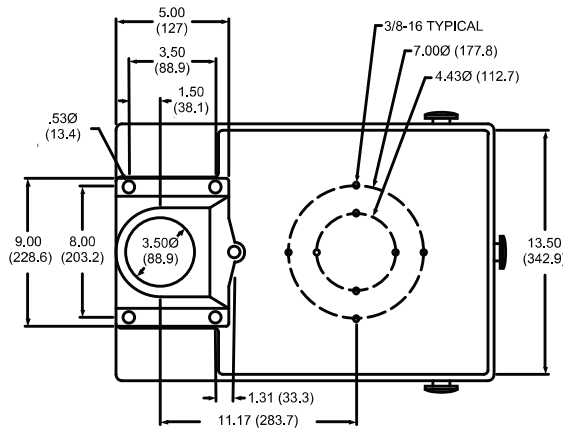
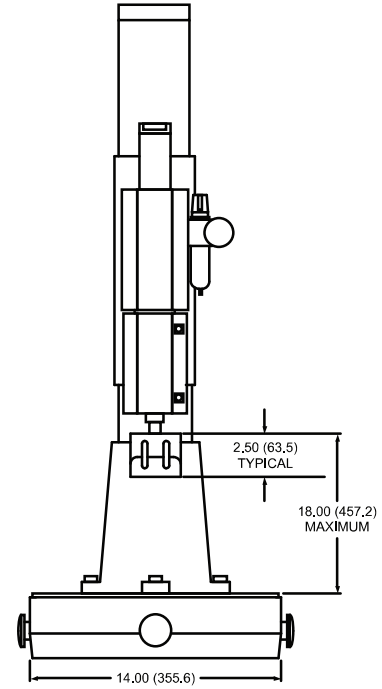
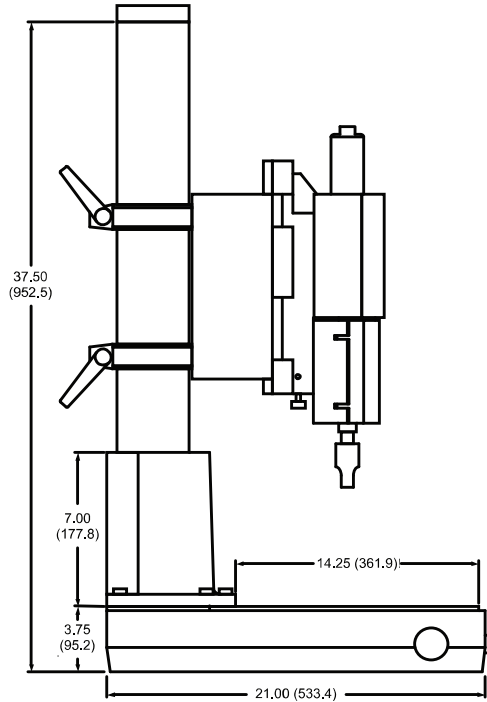

more Power Features

new POWER

Now available in:
15 kHz 2500 watts
20 kHz 1200 watts
20 kHz 2200 watts
30 kHz 1200 watts
40 kHz 800 watts

new FEATURES

- Precision controlled weld depth tolerance of +/- 0.0003 in. (.008 mm)
- Electric stepper motor drive/optical encoder
- Programmable digital force, velocity, distance
- Touch screen technology with dynamic full-color menus
- Virtual Network Computing (tablets/PC's)

STANDARD FEATURES INCLUDE:

- Automatic Frequency Tuning
- Graph Plotting
- Uploadable Event Logging
- Trend Capture / Plotting
- Weld to Peak Power
- Calibration Pulse Prior to Every Weld Cycle
- Weld Set-up Wizard
- Ultrasonics Load Meter Scale
- Absolute and Incremental Distance Modes
- Printer Data Log Output
- Optional PLC I/O (Input/Output) Ports
- Soft Start Overload Protection Circuitry
- Load Regulation Circuitry



SONICS[®]
SONICS & MATERIALS, INC.

e-Press TOUCH

ultrasonic electropress[™]

15 kHz/20 kHz/30 kHz/40 kHz

*high precision plastics welder
with touch control*



Power Supply with built-in Stepper Controller



Leaders in the field of ultrasonic plastics welding equipment and technology since 1969, Sonics & Materials offers its new stepper-motor driven *e-Press Touch*, combined with a unique touch-control power supply with built-in stepper controller. The new system produces repeatable, precision welds to a weld depth tolerance of +/-0.0003 in. (0.008 mm).

The advanced power supply provides superior microprocessor control and consistent reliability, along with an array of convenient networking and plotting features. Power supplies feature smart-logic, user-friendly navigation with touch controls plus enhanced features such as frequency display and digital amplitude control.

Power Supply with built-in Stepper Controller

Dimensions: 10" W x 9.5" H x 24.75" D (254 x 241.31 x 628.65 mm)

Innovating
since

1969

dimensional data

All Dimensions: Inches (mm)

e-Press features

- Single Piece Rigid Cast Aluminum Machine Base and Column Hub
- In-line Load Cell for Precise Force Trigger
- Linear Ball Screw Actuator
- Single Rail Linear Slide
- Rigid Mount Booster Technology

specifications, additional features, and options

Dual Cycle Start Buttons	Standard
Non-Contact Cycle Start Buttons	Optional
Front Emergency Stop	Standard
Head Adjust Counter	
Balance Spring	Standard
Automation Limit Switches	Optional
360° Snap-In Stack Assembly	Standard
Rigid Mount Booster	Standard
Stand Alone Column Hub	Optional
Extended Length Column	Optional
3.75" (95.3) Column Diameter	Standard
3.5" (89 mm) Max Stroke	Standard
Weight	210 lbs. / 95 kg

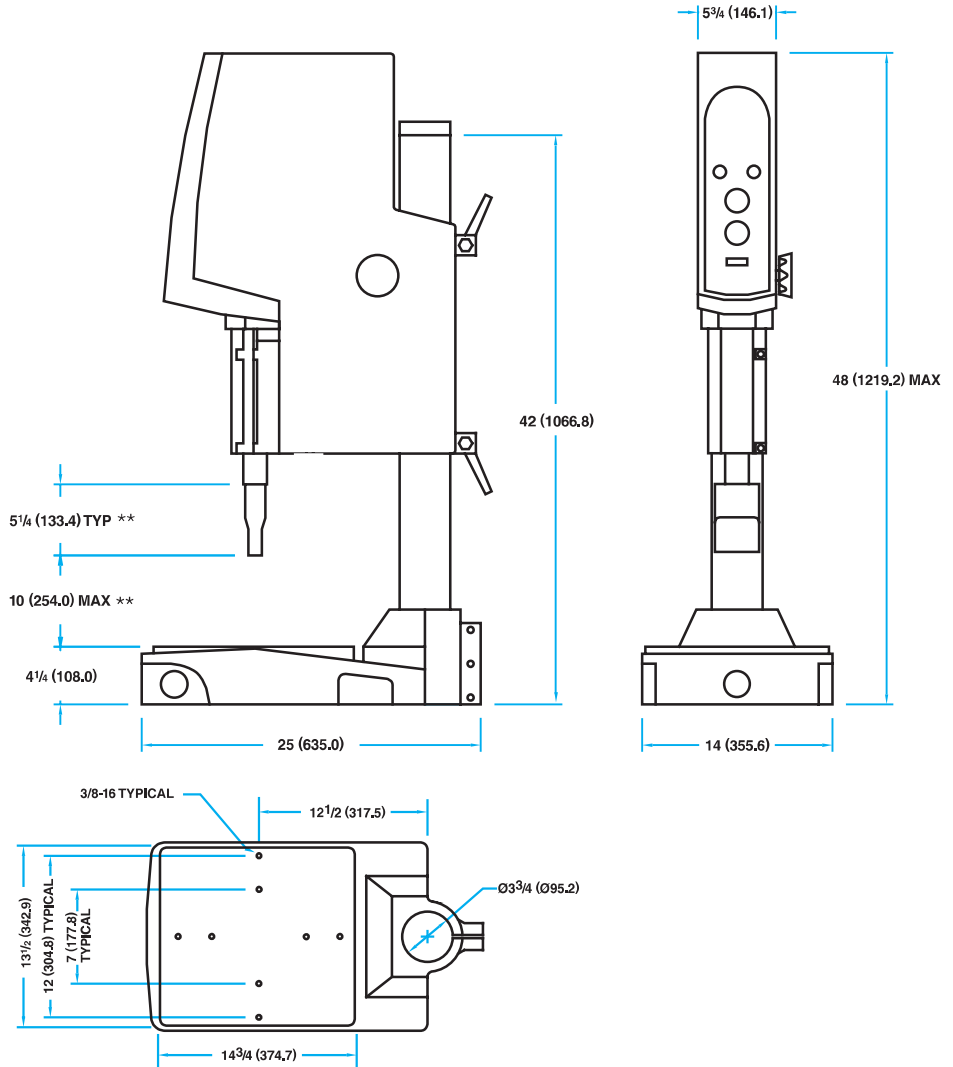

**NOTE: These dimensions apply to 20 kHz model only.

power requirements

Power Supply:

1200 watt	220 VAC (110 VAC Optional)
2200 and 2500 watts	220 VAC

EP controller

110 VAC

