



**SUPERLIFT**  
SANITARY LIFTS

PALLET JACKS

# Stainless Steel Hybrid Pallet Jack

## Your New Warehouse Worker

### Features

- Lithium Battery
- Upright Driving
- Powerful & Portable
- Minimum Maintenance
- Ergonomic Handle Design



Fork



Easier entrance/ exit design for pallet (single wheel available)

Key Switch

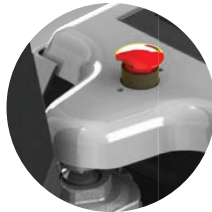

Integral design of key switch and emergency stop

Manual Brake Release



Just use like hand pallet truck

Portable Lithium Battery



2 years warranty | 3 kg / 6.6 lbs  
20 seconds quick change

Hybrid Plus



Powered driving + Powered lifting

Quick Charge



2 hours (option)

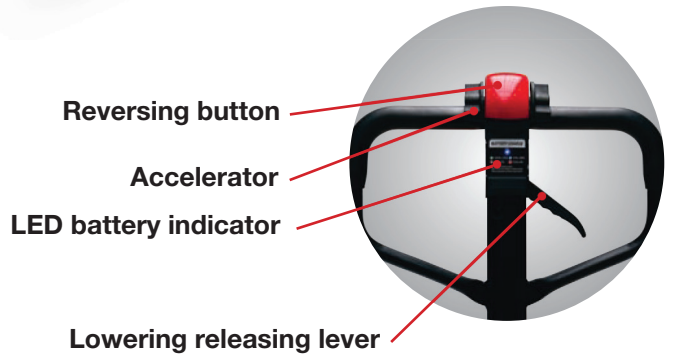

Reversing button

Accelerator

LED battery indicator

Lowering releasing lever

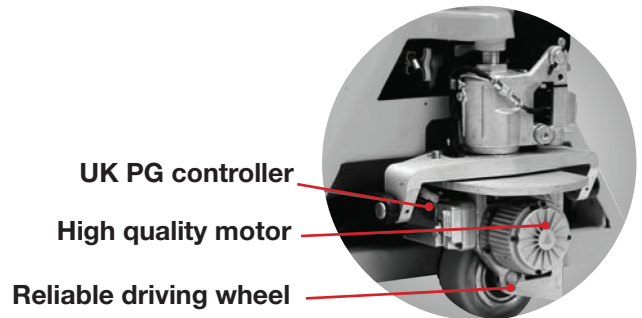

UK PG controller

High quality motor

Reliable driving wheel



**SUPERLIFT**  
SANITARY LIFTS

PALLET JACKS

# Stainless Steel Hybrid Pallet Jack

Your New Warehouse Worker

## Drawings

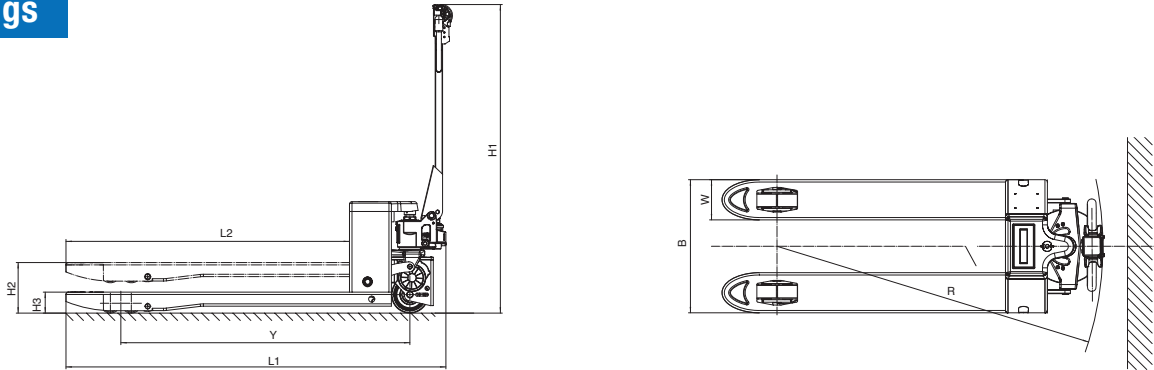

## Specifications

		Metric	Imperial
Model		xxxx	
Operator type		Walkie	Walkie
Load Capacity	Q	1500kg	3000lbs
Load Center	C	600mm	24"
Wheelbase	Y	1170mm/1240mm	46"/48.8"
Service Weight		125kg	275lbs
Overall Height	H1	1250mm	49"
Lift Height	H2	200mm	8"
Fork Height (Lowered)	H3	85mm	3.3"
Overall Length	L1	1540mm/1610mm	60.6"/63.4"
Overall Width	B	540mm/680mm	21"/27"
Fork Size	L2	540x1150mm/680x1220mm	21"x45"/27"x48"
Travel Speed (laden/unladen)		4/4.5kmh	2.5/2.8mph
Max. Gradeability (laden/unladen)	%	3%/20%	3%/20%
Battery Voltage/ Capacity	V/Ah	24V/20Ah Li-Battery	24V/20Ah Li-Battery
Turning Radius	R	1320mm/1390mm	52"/55"