



The Max 250 Heavy Duty Pallet Truck/Forkover

25,000 lbs capacity | SL HDP 250

Go Where Big Rider Trucks Can't Go

Features

- Full Power Steering
- Dual Rear Wheel Drive
- Safe Operator Controlled Speeds
- Small Footprint for Heavy Loads

System specs

Capacity	25,000lbs
Construction	All steel chassis heavy duty weld built
Lowered height	11"
Raised height	17"
Fork	60" OD6 long x 80" long (12" wide forks)
Load wheels	Ø7" x 8
Drive system	Dual Kordel heavy duty with dual 5HP advanced DC motor and Lenz electric brakes
Brakes	Electric
Voltage	24 VDC U.L. 583 type E
Controls	Solid state electronic controller with infinite speed control and battery conservation
Steering	Tilter with power assist
Tire	Ø12" x 5.5" dual drive
Battery comp	Standard battery compartment
Battery connector	Red 375
BDI/Hour Meter	Included with lift lockout





SUPERLIFT
SANITARY LIFTS

ELECTRIC TRUCKS

The Max 250 Heavy Duty Pallet Truck/Forkover

25,000 lbs capacity | SL HDP 250

Sample Drawings

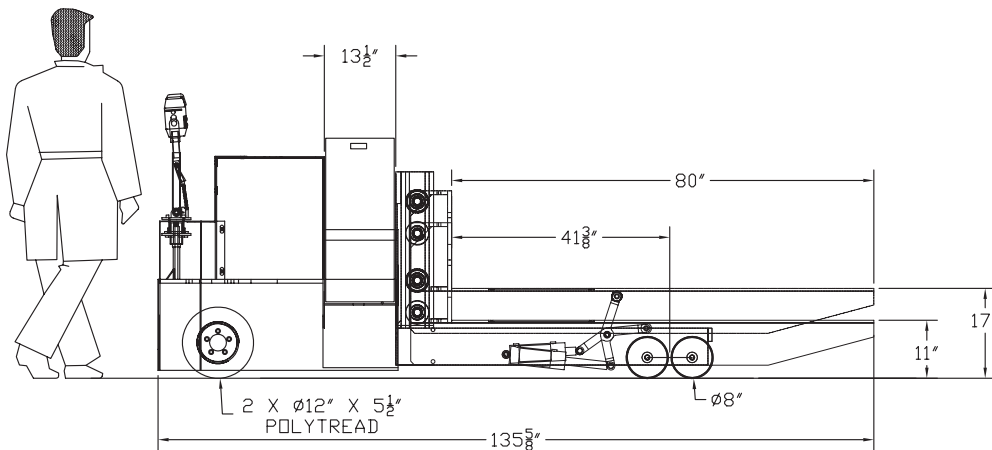
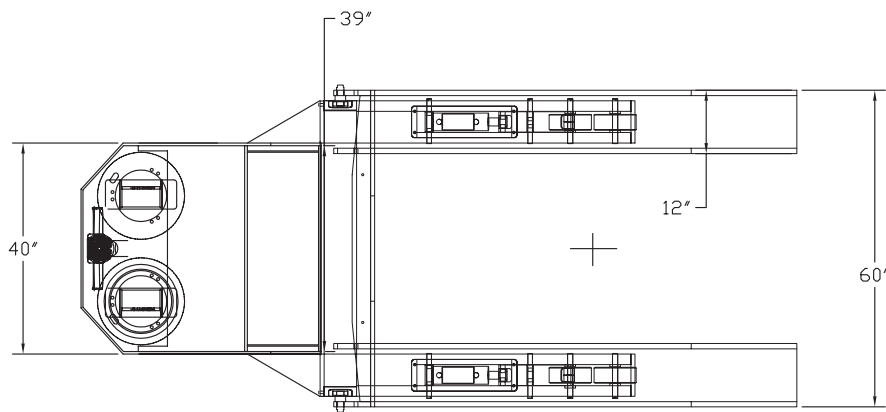

Optional Features

- Platform
- Roll handling
- Coil handling
- Numerous attachments
manlift, high capacity
material lift, crane