



The Max 180 Heavy Duty Pallet Truck/Forkover

18,000 lbs capacity | SL HDP 180

Go Where Big Rider Trucks Can't Go

Features

- Full Power Steering
- Dual Rear Wheel Drive
- Short turning radius for heavy loads
- Optional Fork Dimensions
- With a load capacity of 18,000 lbs @ 43" load center the MAX 180 Powered Pallet Truck can work in the smaller aisles and tight spaces.

System specs

Capacity	18,000lbs
Construction	All steel chassis heavy duty weld built
Lowered height	11"
Raised height	17"
Fork	12" wide x 86" long z 36" between the forks
Load wheels	8" diameter
Drive system	Single heavy duty drive 13.5 with support casters
Brakes	Electric
Voltage	24 VDC U.L. 583 type E/48 volt
Controls	Solid state electronic controller with infinite speed control and battery conservation
Steering	Power steering
Tire	13.5" x 5" Polyurethan drive
Battery comp	11" x 16.5" long compartment, dual
Battery connector	SB-175 Red
BDI/Hour Meter	Included with lift lockout
Paint	Enamel paint
Note	C/V Strobe light and sound alarm





SUPERLIFT
SANITARY LIFTS

ELECTRIC TRUCKS

Heavy Duty Pallet Truck / Forkover

18,000 lbs capacity

Sample Drawings

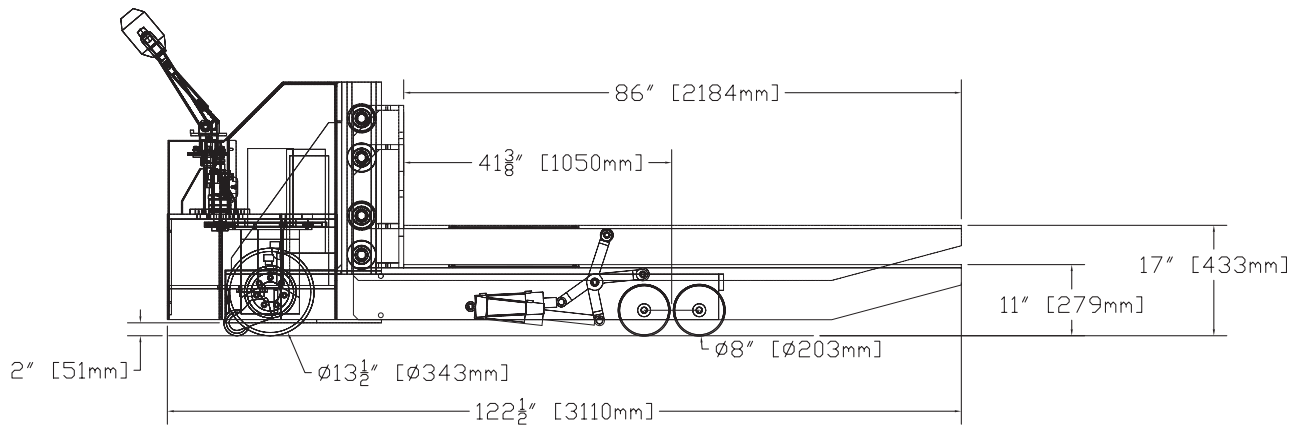

Superlift high performance walk behind pallet truck/fork over capacity to 18,000 lbs with the safety of a pedestrian truck and efficiency of a rider.

Optional Features

- 24 volt or 48 volt power
- 2 battery positions available
 - Standard front battery
 - Standard front battery
- Saddle bag style for tight turning radius
- Superior lifting power
- Compact with 2" ground clearance
- Rubber covered forks available for moving delicate loads
- Multiple fork options available