

Aerion Range

Vue 1410 Tunnel

SPECIFICATION SHEET

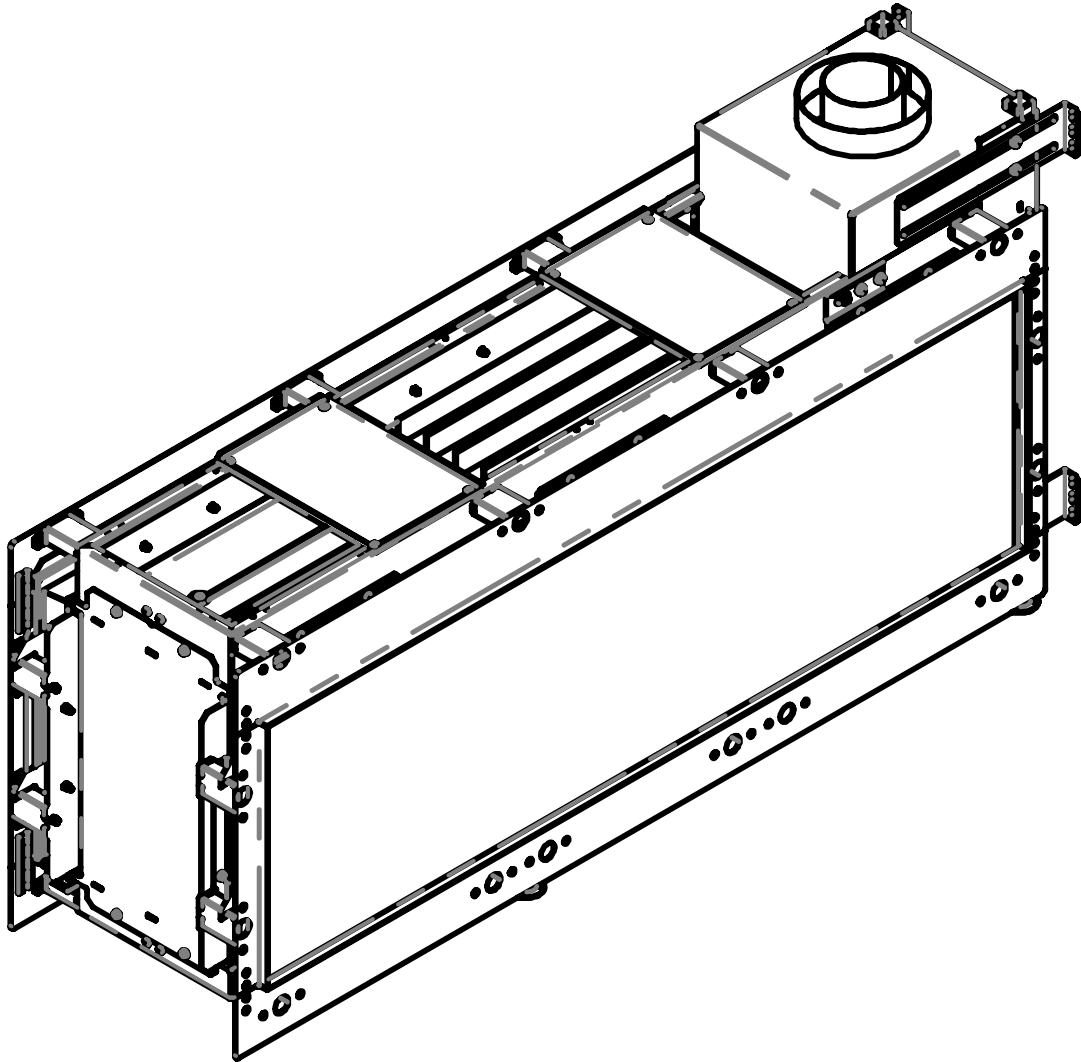

Version 2 21/4/21

Contents of manual may be updated without notice.

For the latest version of this manual please refer
to our website: www.livingfire.com.au

PAUL AGNEW

DESIGNS

VUE 1410 TUNNEL

APPLIANCE DIMENSIONS

Product Code: G1410 T

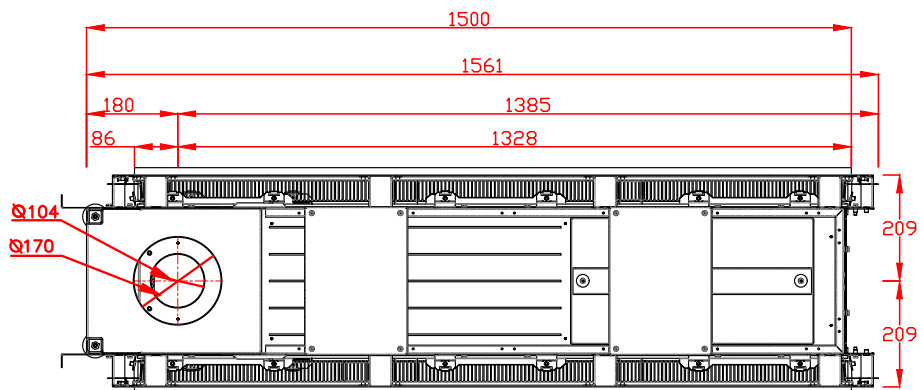
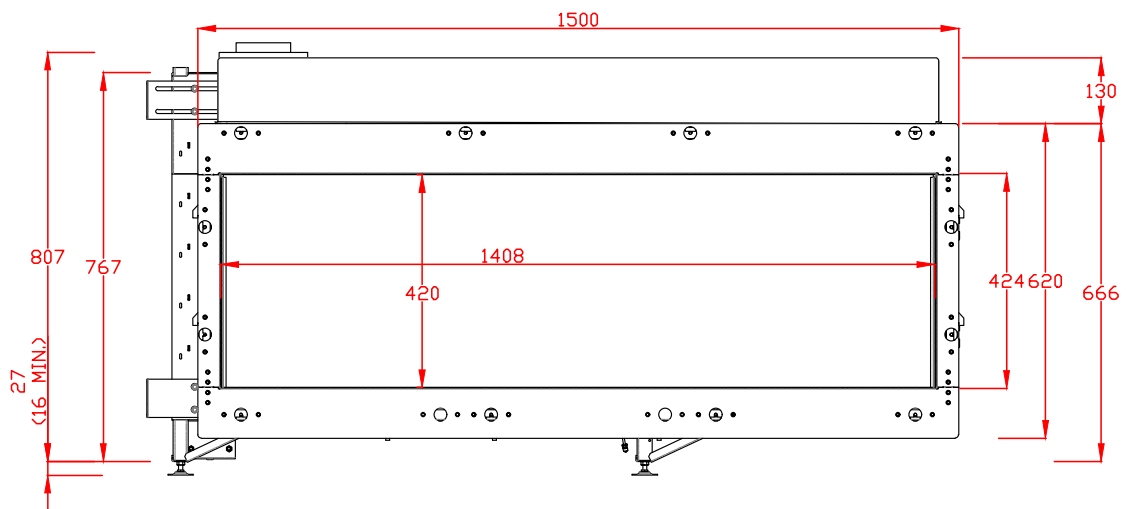
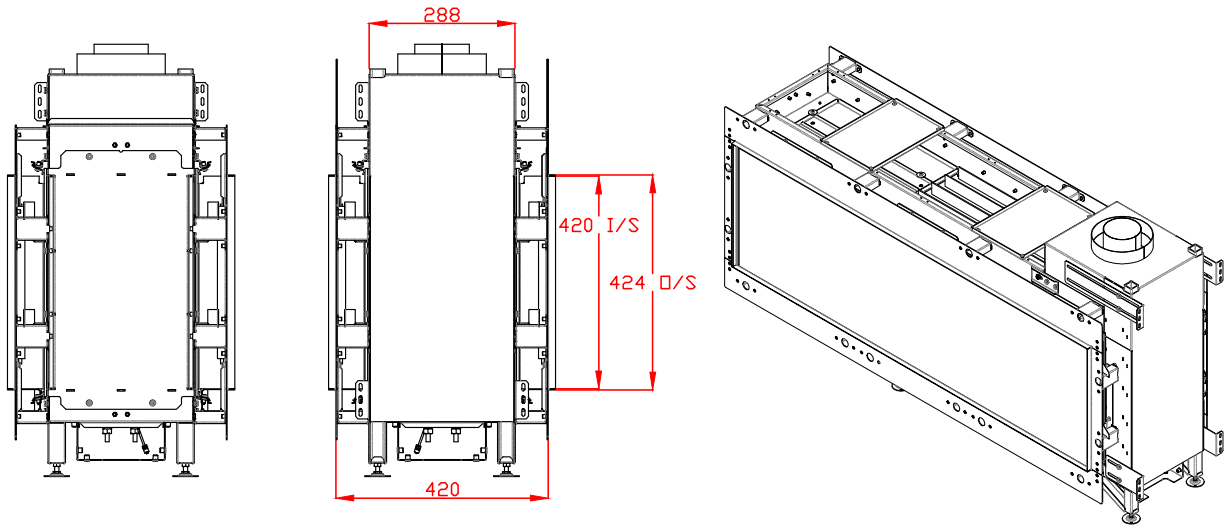

Note:

The lip around unit is 20mm thick.

VUE 1410 TUNNEL

CONVECTIONAL HEAT

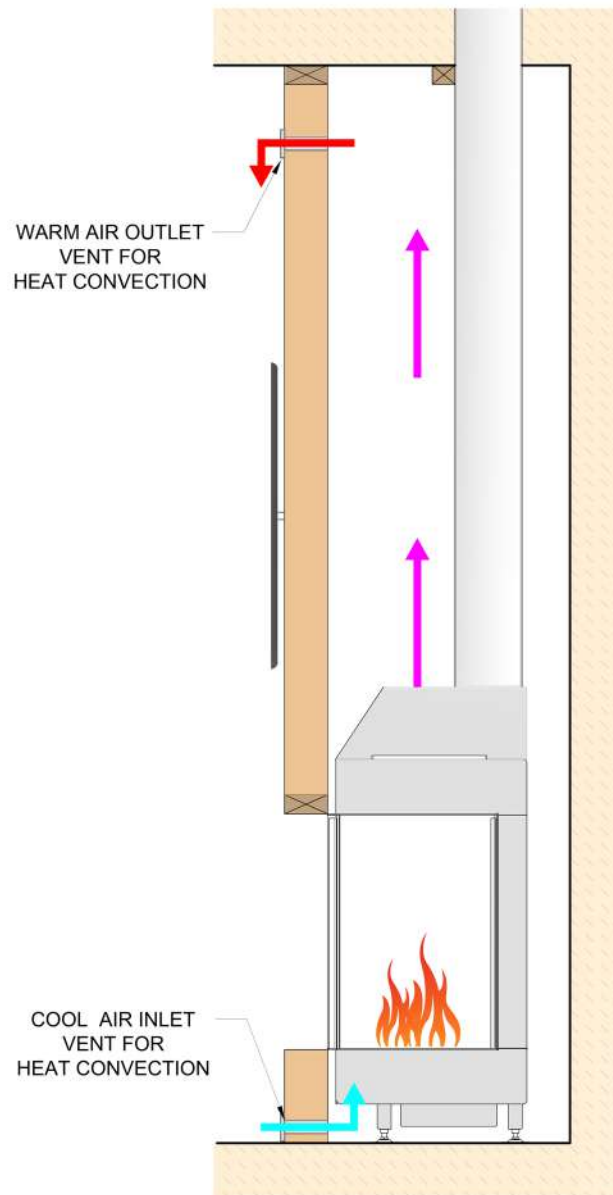

Figure 1.1 (Convective heat through vents)

Overall Design:

- One of the many features of the Paul Agnew Designs gas fireplaces is its use of convective air flow.
- As the air within the enclosing walls, or chase, is warmed by the fireplace it rises and then exits the convection air outlets. The warm air in the chase is then replaced by room air which enters through the room air inlets which are situated at the bottom of the enclosure. As this warm air cool, it falls toward the floor where it's drawn into the inlet and the cycle repeats.
- The room air inlets are part of the fireplace and cannot be blocked. The amount of square area required for your convective air outlets is determined the enclosure construction.
- As seen in the illustrations below, the outlets may be placed in a number of locations to accommodate different structures/designs. In all cases, the design must allow for free flow air through the chase/enclosure.

VUE 1410 TUNNEL

VENT LOCATIONS AND SIZES

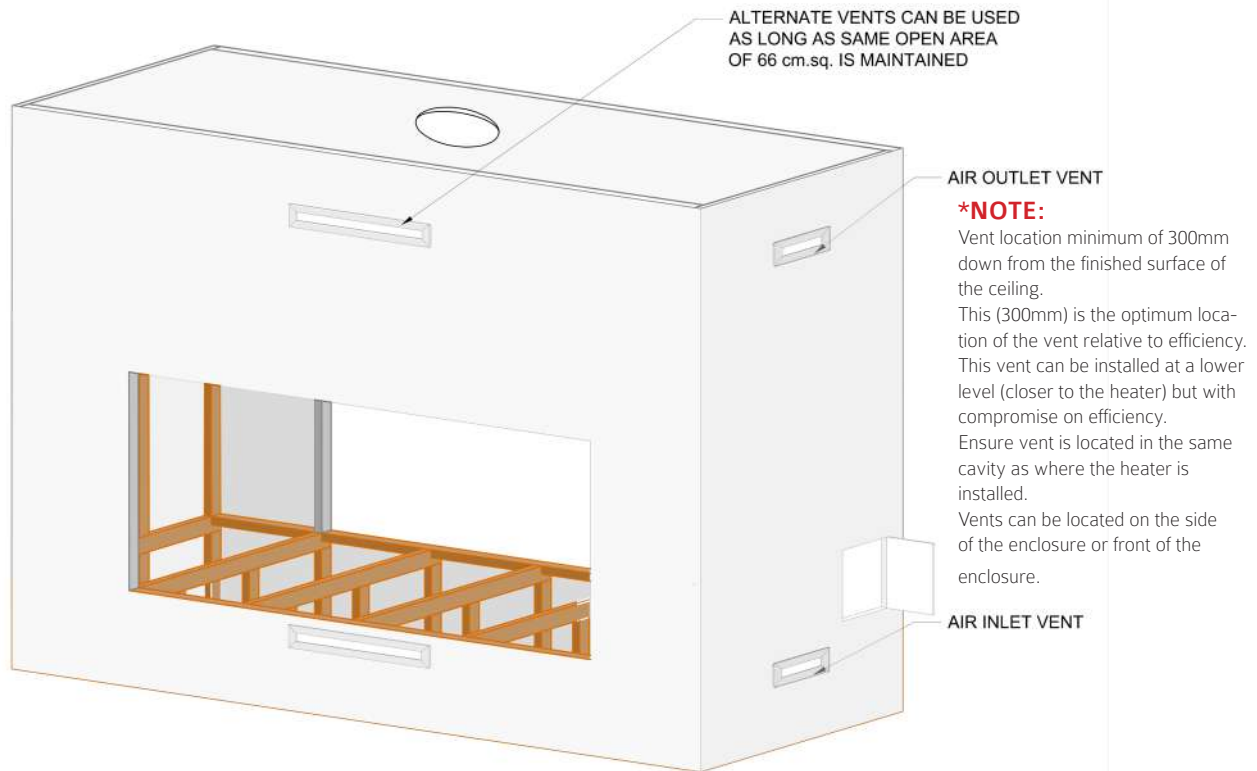

Figure 1.2 (Vents)

NOTE:

Standard Vent Size:

270x80mm

Standard Vent Opening:

218x30mm

For Timber Frame:

x 2 minimum vents required
x 4 vents for more efficient heat dispersion.

For Steel Frame:

x4 minimum vents required for airflow.

* Vent sizes can be customised.

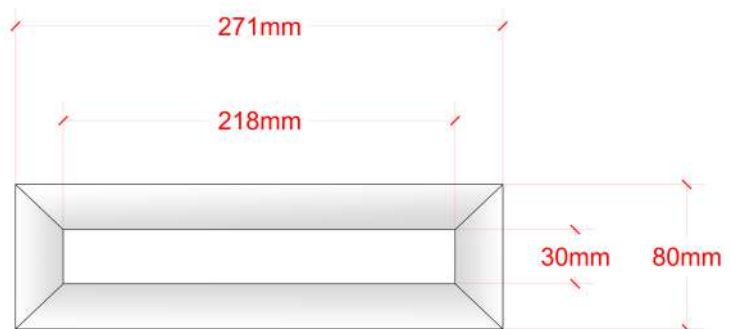

Figure 1.3 (Vent Size)

VUE 1410 TUNNEL

UNIT TO TV CLEARANCES & COMBUSTIBLE MANTLE

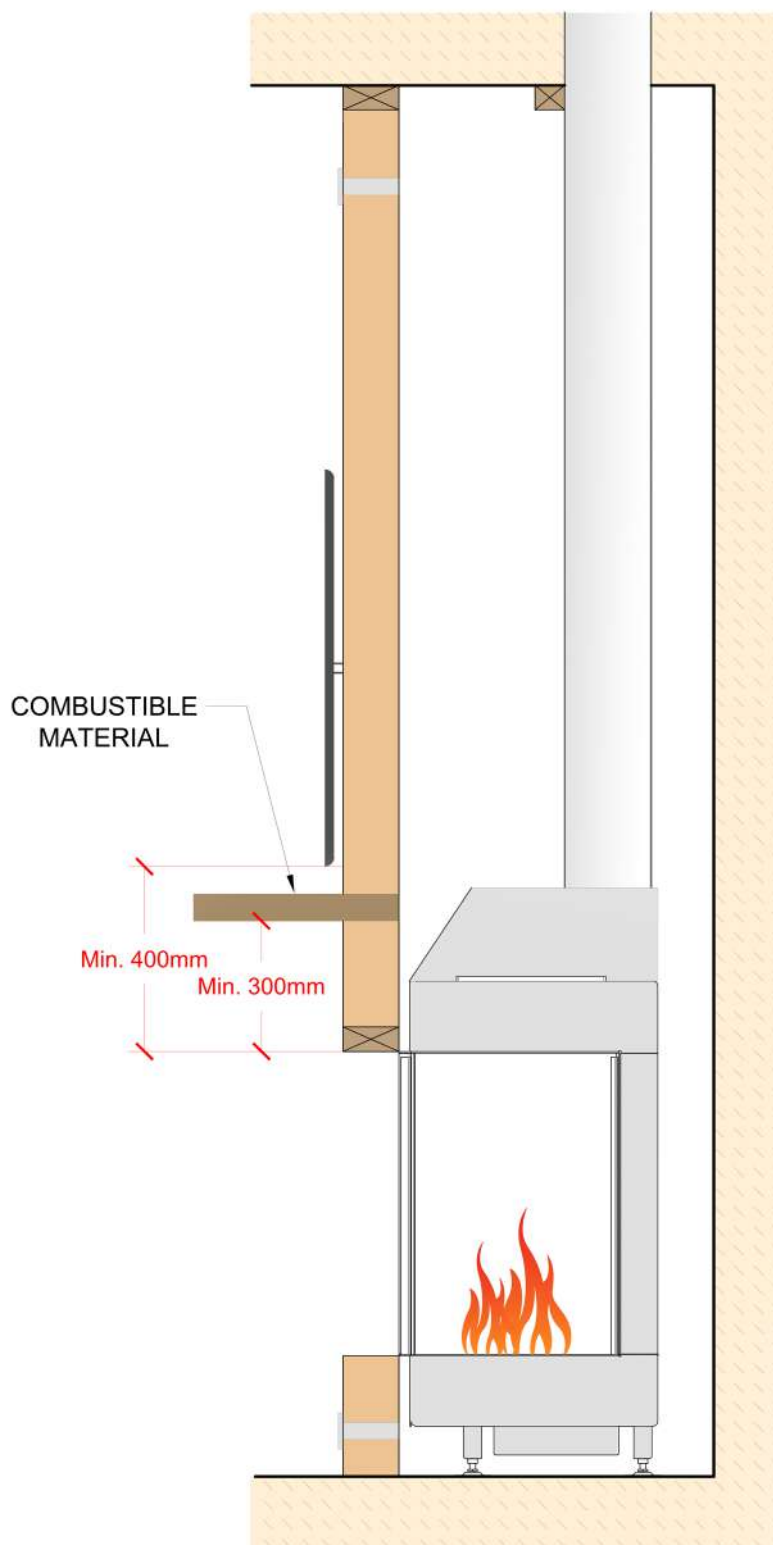

Figure 1.4 (Clearance from Unit to TV)

VUE 1410 TUNNEL

CONTROL PANEL

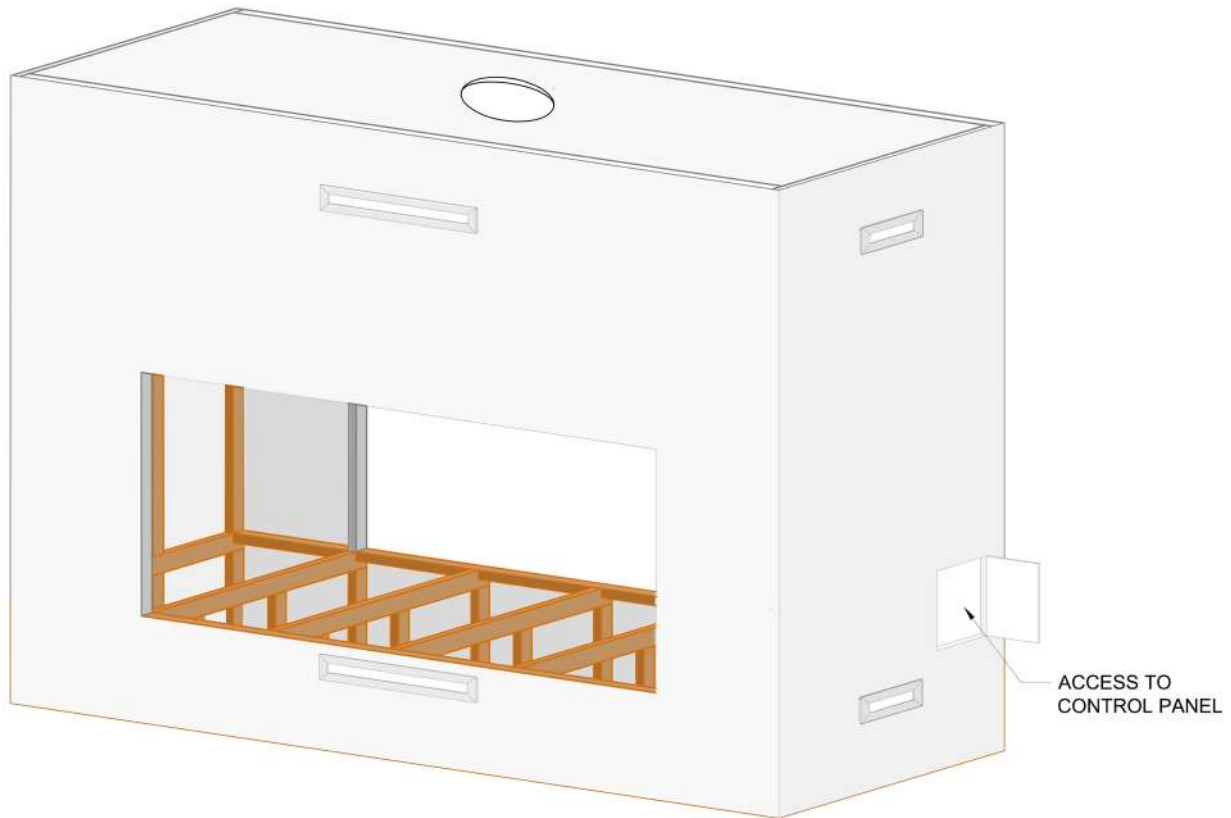

Figure 1.5 (Control panel location)

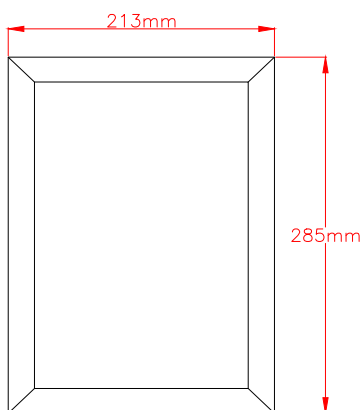

Figure 1.6 (Control Panel)

Control Box Installation:

Timber Installation:

Unit stands on small legs that sit on framing/floor which provide sufficient clearance for airflow. If unit is mounted on floor, control panel can only be located to the side with the minimum clearance of 250mm to the side. If underneath the unit, base will need to be at a desired height for the unit but also allowing the control box to be located underneath. Please refer to dimensions of each unit.

VUE 1410 TUNNEL

CLADDING MATERIAL

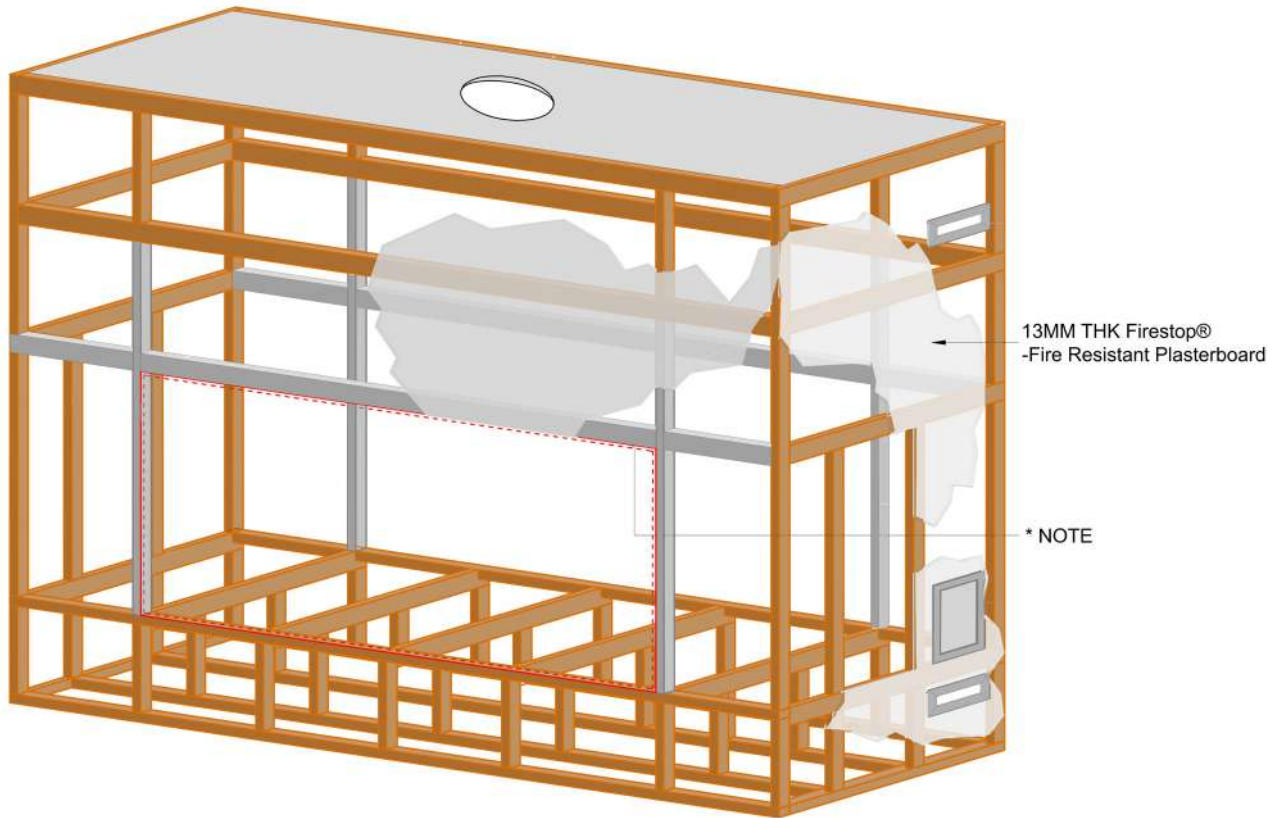

Figure 1.7 (Cladding Material)

Note:

A gap of 4mm needs to be left between the villa board and the top part of the firebox.
9mm Villa Board can be used as an alternative approved cladding material

VUE 1410 TUNNEL

TIMBER FRAME

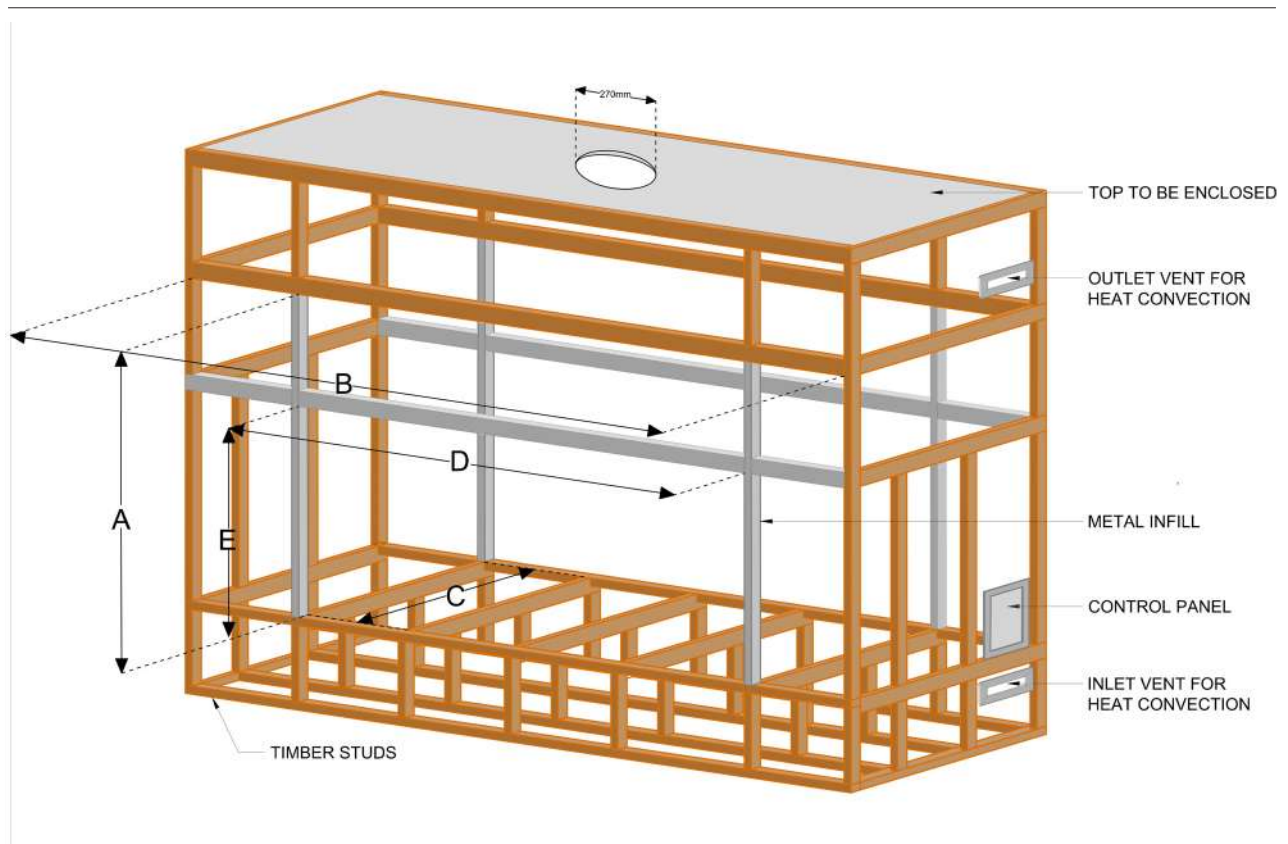

Figure 1.8 (Timber framing)

CLEARANCE TO COMBUSTIBLES

Fireplace Dimensions			Timber Frame			Metal Studs Infills to be installed after Unit is in place (Clearance between unit and metal stud infill)		Option for smaller depth clearance: Metal Studs fixed to rear combustible wall. 25mm Steel Battens fixed to combustible wall +6mm Villa Board + 50mm air gap to unit
In mm			Clearance to Combustibles in mm			Installation dimensions in mm		
H	W	D	Unit Height +500mm top	Unit Width +250mm each side	Unit Depth +250mm to back	Unit Width +50mm either side	Unit Height +150mm top	Unit Depth + 81mm
850	1500	420	A	B	C	D	E	C*
			1350	2000	N/A	1600	1000	N/A

Note:

Please refer to Pg. 3 for specifications regarding Vents and pg. 5 for Control Panel specifications.

VUE 1410 TUNNEL

METAL FRAME

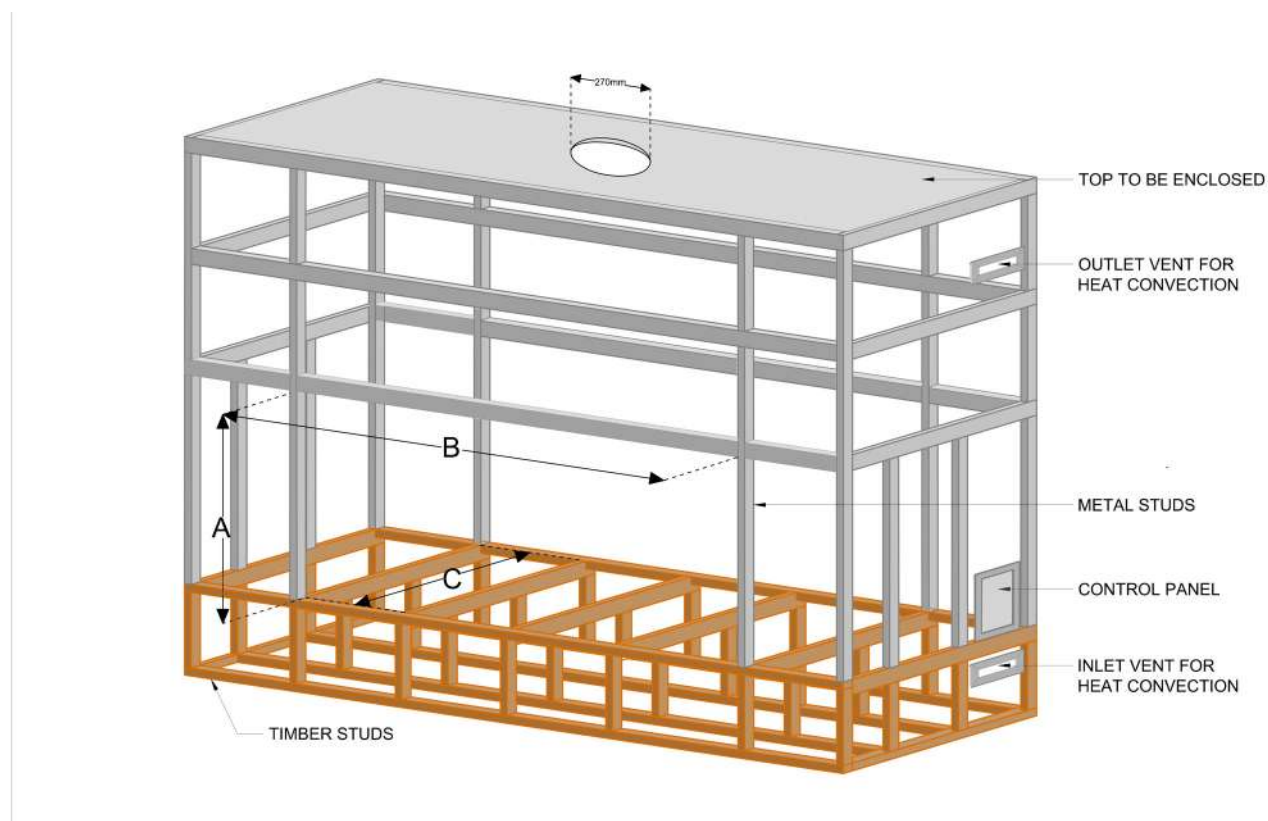

Figure 1.9 (Metal framing)

CLEARANCE TO COMBUSTIBLES

Fireplace Dimensions			Metal Stud Frame		
In mm			FOR METAL STUD FRAME, UNIT MUST BE IN PLACE		
			Clearance to the inside of the metal stud		
			Unit Height +50mm top	Unit Width +150mm either side to internal side of metal stud	Reduced Depth Clearance N/A for Tunnel Units Metal Studs fixed to rear combustible wall. 25mm Steel Battens fixed to combustible wall +6mm Villa Board +50mm air gap to unit
H	W	D	A	B	C
850	1500	420	900	1800	N/A

Important:

Unit needs to be in place while building into metal studs. Otherwise the measurements must be bigger. The clearances to combustibles is 500mm to the top of the unit and 250mm on either side.

Note:

Please refer to Pg. 2 for specifications regarding Vents and pg. 4 for Control Panel specifications.

VUE 1410 TUNNEL

REGULATORY COWL LOCATIONS

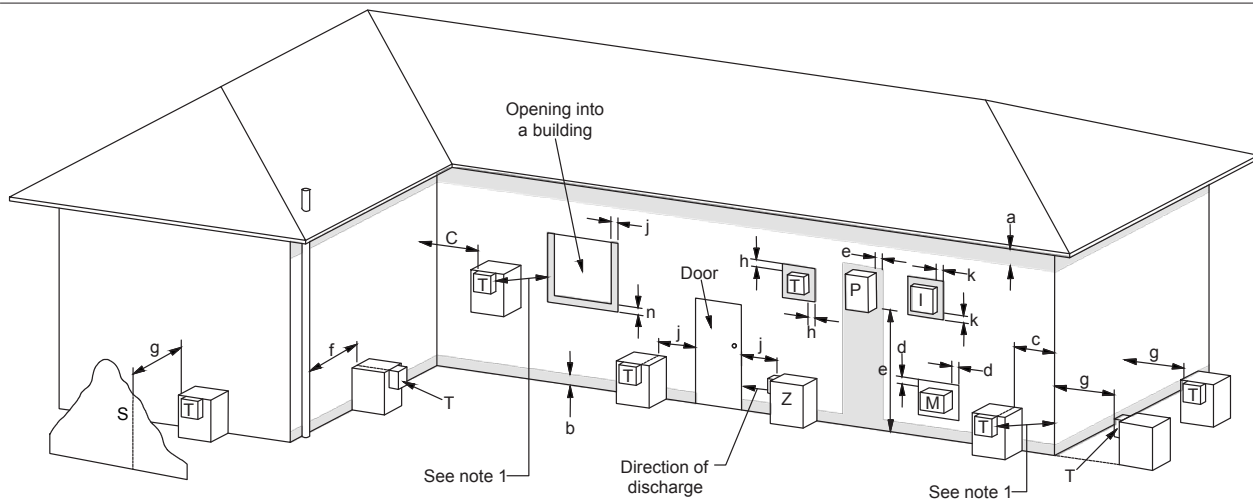

Figure 2.0 (Location of flue terminals of balanced flue, room-sealed, fan-assisted or outdoor appliances)

Ref.	Item	Minimum clearances mm	
		Natural draught	Fan assisted
a	Below eaves, balconies and other projections:		
	For appliances up to 50MJ/h input	300	200
	For appliances over 50MJ/h input	500	300
b	From the ground, above a balcony or other surface*	300	300
c	From a return wall or external cover*	500	300
d	From a gas meter (M) (see Note 5) (see Clause 5.11.5.9 for vent terminal location of regulator) (see Table 6.7 for New Zealand requirements)	1000	1000
e	From an electricity meter or fuse box (P)• (see Note 5)	500	500
f	From a drain pipe or soil pipe	150	75
g	Horizontally from any building structure* or obstruction facing a terminal	500	500
h	From any other flue terminal, cowl, or combustion air intake*	500	300
j	Horizontally from an openable window, door, non-mechanical air inlet, or any other opening inot a building with exception of sub-floor ventilation:		
	Appliances up to 150 MJ/h input*	500	300
	Appliances over 150 MJ/h input up to 200 MJ/h input*	1500	300
	Appliances over 200 MJ/h input up to 250 MJ/h input*	1500	500
	Appliances over 250 MJ/h input*	1500	1500
	All fan-assisted appliances, in the direction of discharge	-	1500
k	From a mechanical air inlet, including a spa blower	1500	1500
n	Vertically below an openable window, non-mechanical air inlet, or any other opening inot a building with the exception of sub-floor ventilation:		
	For space heaters up to 50 MJ/h input	150	150
	For other appliances up to 50 MJ/h input	500	500
	For appliances over 50 MJ/h input and up to 150MJ/h input	1000	1000
	For appliances over 150 Mj/h input	1500	1500

Legend:

- I = Mechanical air inlet
- M = Gas meter
- P = Electricity meter or fuse box
- S = Structure
- T = Flue terminal
- Z = Fan-assisted appliance only
- Shading indicates prohibited area for flue terminals

Notes:

- 1) Where dimensions c, j, k cannot be achieved an equivalent horizontal distance measured diagonally from the nearest discharge point of the terminal to the opening may be deemed by the Technical Regulator to comply.
- 2) See Clause 6.9.4 for restrictions on a flue terminal under a covered area.
- 3) See Figure J3 (from AS/NZS 5601) for minimum clearances required from a flue terminal to an LPG Gas cylinder. A flue terminal is considered to be a source of ignition.
- 4) For minimum clearances not addressed above acceptance should be obtained from the Technical Regulator.
- 5) Minimum clearances d and e also apply to any combustion air intake openings of appliances.

* Unless appliance is certified for closer installation
 • Prohibited area below electricity meter or fuse box extends to ground level