

WASHTECH

OPERATOR MANUAL **XL**



GENERAL WARNINGS



Non-compliance with warnings or failure to follow the instructions in this manual can result in loss of life, severe personal injury and / or serious damage to property.

Before installation, commissioning and / or repair of the machine you must carefully read the safety instructions and warnings and all warning labels attached to the machine.

Hazards can include high surface temperatures, hot water, caustic detergent, sharp edges including broken glass and knives left in the wash chamber, and dangerous electrical voltages.

All service work must be carried out by qualified personnel only who ensure compliance with all local codes and standards including AS/NZS 3500.1.

The electrical supply must be turned off at the wall before accessing the machine for servicing. All electrical terminals must be covered at all times to prevent access to the terminal. Appropriate electrical tests must be carried out after any and all service repairs.

IMPORTANT INFORMATION



Failure to comply even partially with the instructions given in this manual will invalidate the product warranty and relieve the manufacturer of any responsibility. This includes failure to supply the machine with good quality water at suitable pressure as specified.

The alteration of machine operation or design or replacement of parts not approved by the manufacturer may void warranties and approvals.

This machine is intended for commercial use only. It is designed for the cleaning of fresh food waste from cutlery, crockery, glassware, containers and food preparation equipment. Consult the manufacturer regarding suitability for other applications.

No part of the machine is designed to be stepped upon.

This machine is not a waste disposal unit.

It is essential that operating procedures are followed including adequate pre-rinsing or scraping of loose soil or waste from washware before it is placed in the machine, and regular cleaning and maintenance of the machine.

Regular servicing is essential for optimum performance and long machine life. Maintenance by a dishwasher technician is recommended every 6 months or 15,000 cycles to ensure all systems are operating correctly and consumable items – such as chemical squeeze tubes – are replaced prior to degradation of performance and/or failure.

The information contained in this document is checked, reviewed and updated regularly to ensure that it is accurate and relevant to the model described. However, discrepancies and errors can occur. We welcome your feedback.

This document is subject to change without prior notice.

Information supplied in this manual is copyright. No part of this work may be reproduced or copied in any form or by any means, electronic or mechanical without the express permission of Washtech.

CONTENTS

2. General Warnings
3. Contents
4. Safety Instructions
5. Installation Diagram
6. Installation Instructions
8. Installation Checklist
9. Installation Troubleshooting
10. Operator Use Guide
11. Operator Troubleshooting
12. Schematic Diagram
13. Accessories
14. Spare Parts List
15. Spare Parts List



SAFETY INSTRUCTIONS

Installation

- Use qualified, skilled personnel.
- Follow installation instructions.
- Connect to correct voltage and supply current, and (if applicable for the model) check that the phase rotation is correct.
- Provide fully accessible Electrical Isolation Switch & water supply valves.

Training and Supervision

- Read and Understand the Operating instructions and train all staff.
- This appliance must not be operated by children or infirm persons.
- Machine panels must only be removed by suitably qualified and trained personnel – internal hazards include live electrics and very hot surfaces.
- No part of this appliance is intended for use as a stepladder.

Hot Surfaces

- Some surfaces may be hot or very hot.

Chemicals

- Commercial dishwashing detergents are hazardous – handle with care.
- Read and follow the safety information found on the labels of detergent containers and Material Safety Data Sheets.
- Use protective eyewear and clothing if decanting containers.

Hot Water

- Do not put hands in wash water which may be over 60°C and contain hazardous caustic detergent.
- Rinse water can be over 90°C.
- Door safety switches are designed for emergency use only.

Cleaning

- Do not hose down the machine or splash water over the exterior.
- Watch for broken glass etc. when cleaning the inside of the machine.

Warnings



Equipment contains dangerous voltages and can be hazardous if installed or operated incorrectly. Non-compliance with Warnings or failure to follow the instructions contained in this manual can result in loss of life, severe personal injury or serious damage to property.

Installation and servicing must be carried out by a suitably qualified person in compliance with all local codes and standards including AS/NZS 3500.1.

INSTALLATION DIAGRAM

XL SERIES-3

- Part #: XL3 INST
- Date: 09/02/2023
- Version: 3-A

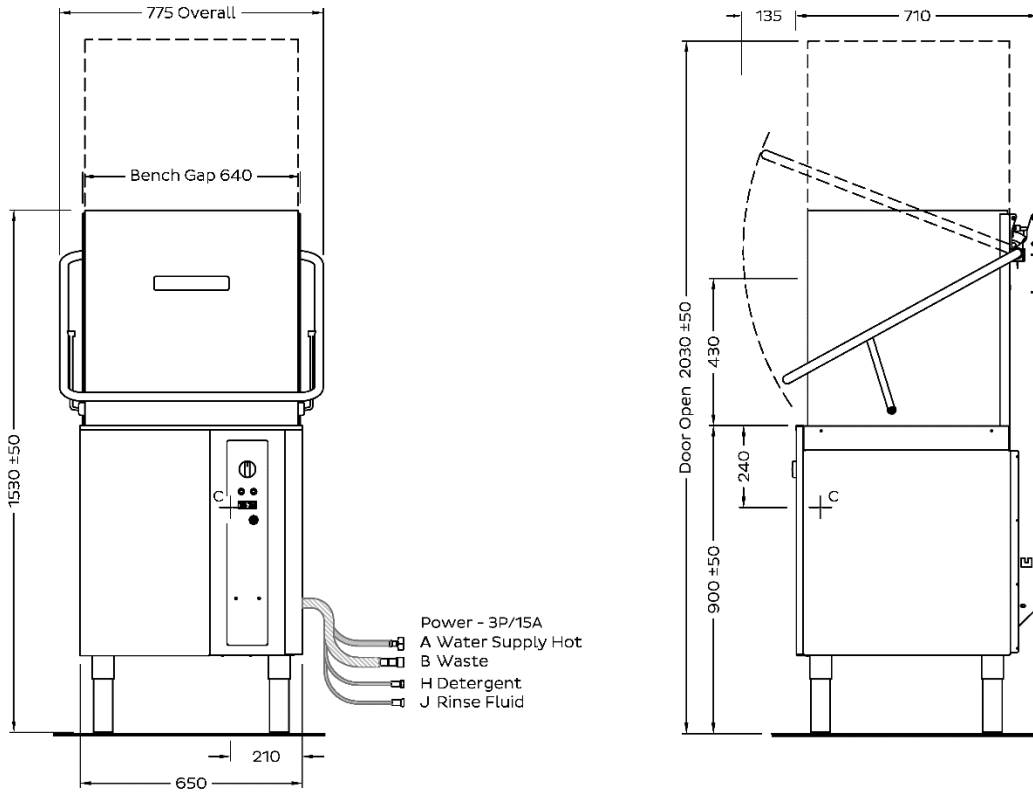

Bench detail

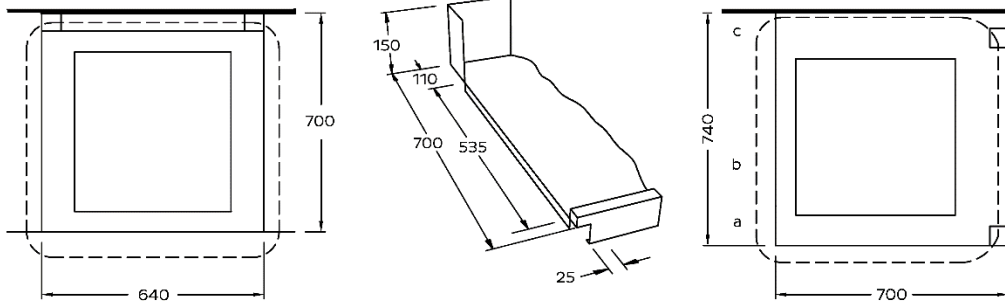

Corner Installation Notes

- a Machine must face left for easy access to controls
- b Allow 300 clearance to front for service access
- c Splashback return to be no higher than 150

Services

A	Hot water 65°C	200-350 kPa	3/4"
B	Waste - tank drainage point	1.5" BSP	40mm
C	Electrical connection	400-415V, 50Hz, 3P-N+E-	15A
	or	230-240V, 50Hz, 1P-N+E-	25A
		230-240V, 50Hz, 1P-N+E-	15A

Note: Isolating switch must be within 1m of, and not directly behind the machine. Isolating water valve must be readily accessible

INSTALLATION INSTRUCTIONS

MACHINE POSITIONING

- Unpack machine, check for damage and complete delivery.
- Install machine on sound waterproof self-draining floor and use adjustable feet to level machine.



NOTE: Failure to level the machine correctly may result in leaking during the cycle, overflowing from the door sill, poor hygiene through the wash tank not being able to drain correctly, and/or visibly uneven door.

- Allow room for detergent to one side of machine or in adjacent cupboard. 20 litre container requires approximately W 250mm x D 350mm x H 450 mm, but smaller containers are available from many suppliers.
 - The front panels are adjustable down to 605mm; however, the upper sill is fixed at 650mm.
 - The drain hose can be routed out either side or the lower rear of the machine.
 - The rear panel may be removed when installing against a wall.

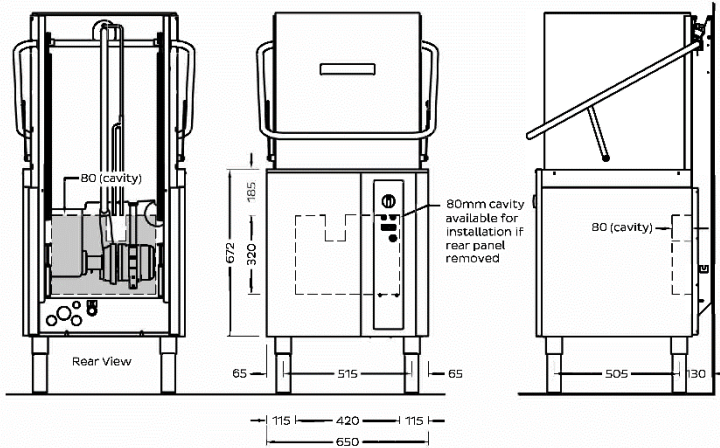

INLET WATER

Incoming water should be within the following standard requirements:

- Temperature: 65°C.



NOTE: Low temperatures will increase the recovery time between cycles and depending on the chemical being used, may result in excessive foaming if the machine is started before the wash water is up to a suitable temperature.

NOTE: Excessively high temperatures may damage the solenoid which can result in flooding should this component fail. High temperature solenoids are available and can be retrofitted if necessary.

- Connection: 20 mm (3/4" BSP) male – flexible hose supplied.

NOTE: Flush supply line before connection. Poor quality supply or excessive water hardness may affect performance or damage machine – filtration and/or softening is recommended.
- Flow rate: minimum 20 litres per minute.
- Pressure: between 200 and 350 kPa.

NOTE: If water pressure is above 350kPa, fit pressure limiter valve (PLV). Do not use small diameter plastic supply lines.
- Consumption: Approximately 2.6 litres per cycle.
- Backflow prevention: Atmospheric Vacuum Breaker (AVB) fitted standard.

WATER QUALITY REQUIREMENTS

The incoming water should also be within the following parameters:

TDS	ppm	pH				
min	1	7				
max	135	8				
Ions	Cl ⁻	SO ₄	Fe	Mn	Cu	Cl ₂
Max mg/L	100	400	0.1	0.5	0.05	0.1



NOTE: Levels above or below the stated requirements can be expected to increase component wear and reduce the expected useful life of the dishwasher. If in doubt, it is best to consult a water specialist and have the incoming water professionally tested and treated if necessary.

INSTALLATION INSTRUCTIONS

POWER

- Electrical supply required is 15A 230-240V, 50Hz via switched outlet adjacent to machine.
- Easily upgradeable to three phase 15A 400-415V 50Hz.



NOTE: Equipment contains dangerous voltages and can be hazardous if installed or operated incorrectly. Non-compliance with warnings or failure to follow the instructions contained in this manual can result in loss of life, severe personal injury or serious damage to property.

CHEMICAL

- This dishwasher is supplied with Detergent and Rinse Fluid injector pumps.
- To connect to chemicals, insert pump inlet hose into container of commercial low foam detergent and rinse fluid.

NOTE: Externally adjustable chemical pumps are fitted and pre-set at an average level, these need to be calibrated on site according to the chemical being used and site-specific conditions such as the water quality and how the machine is being used. Failure to do so may result in excessive dosing which can result in foaming and overflowing, or insufficient dosing which can cause inferior wash results and impact components through a build-up of grease. If in doubt, contact your chemical company for assistance.



NOTE: Commercial detergents can be hazardous – read instructions, store safely and handle with care. Care needs to be taken when changing chemicals, ensuring that the detergent is not accidentally connected to the rinse fluid inlet line.

NOTE: Avoid using excessively chlorinated chemicals along with domestic tablets, both of these can cause damage to machine.

NOTE: If uncertain, please consult a chemical specialist for assistance in selecting the right chemicals and calibrating machine settings to suit this along with your unique site conditions and requirements.

WASTE

- Connect drain pump hose supplied to a vented upstand or sink waste connection.

NOTE: Failure to correctly connect the drain hose and ensure correct plumbing is in place beyond this may result in blockages, backflow from the sink and/or flooding of the machine.



NOTE: Either copper or PVC may be used for the waste connection – PVC is more resistant to some harsh detergents. It is important to note that 90°C rinse water mixes with the 60°C – 65°C wash water before discharge and then flows into the trap where the water is further cooled before entering the drainage plumbing.

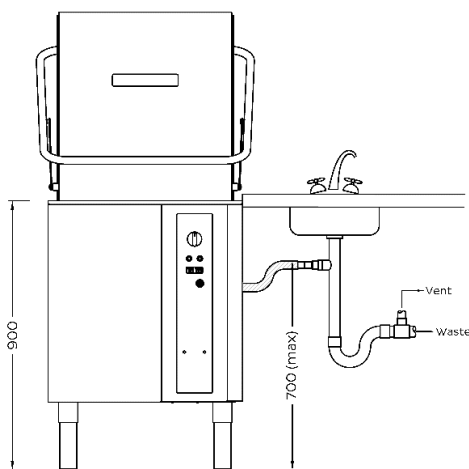

- Drain connection should not exceed 550mm of the base of the dishwasher (700mm based on install at a 900mm bench height).
- The drain hose can be routed out either side or the lower rear of the machine.
- Optimal drain hose installation is to a low connection or standpipe that enables a consistent fall from the outlet of the machine (this limits residue remaining in the line and extends the useful life of the hose).
- Ensure that the drain hose is not kinked.
- Do not leave the drain hose loosely on the ground as this will damage the hose over time causing premature failure.

INSTALLATION CHECKLIST

- Complete attached Installation Checklist to ensure machine is installed and running correctly, and operator is familiar with operating procedures.

OPERATOR TRAINING

- Ensure operators are aware of the operator procedures along with daily and weekly cleaning requirements.
- Check that they have read and have retained a copy of the Operator Use Guide.

INSTALLATION CHECKLIST

CHECK	NOTES				
DELIVERY					
SUPPLIED COMPLETE?	<input type="checkbox"/> CHECK THERE HAS NOT BEEN ANY TRANSIT DAMAGE				
POSITION					
LEVEL AND STABLE?	<input type="checkbox"/> ON SOUND, WATERPROOF, SELF-DRAINING FLOOR				
WATER					
ISOLATOR VALVE FITTED?	<input type="checkbox"/> ACCESSIBLE, ALL FITTINGS SOUND, AND NO LEAKS				
TEMPERATURE CORRECT?	<input type="checkbox"/> HOT WATER INLET 65°C				
PRESSURE CORRECT (200 – 350 kPa)?	<input type="checkbox"/> LIMITER FITTED IF ABOVE RANGE				
FLOW RATE CORRECT (≥ 20L PER MIN)?	<input type="checkbox"/> FLOW RATE AT OR ABOVE MINIMUM RANGE				
QUALITY WITHIN REQUIREMENTS?	<input type="checkbox"/> FILTER OR SOFTENER IN PLACE IF OUTSIDE REQUIREMENTS				
POWER					
ISOLATING SWITCH?	<input type="checkbox"/> FITTED, FUNCTIONAL AND ACCESSIBLE				
CORRECT SUPPLY?	<input type="checkbox"/> VOLTAGE, CURRENT, CIRCUIT BREAKER ALL CORRECT				
WASTE					
CONNECTION TO STANDPIPE/SINK WASTE?	<input type="checkbox"/> CORRECT CONNECTION TO PLUMBING				
CHEMICALS					
	CHEMICAL NAME	CONTAINER	NO LEAKS	PRIMED	CALIBRATED
DETERGENT	_____	<input type="checkbox"/>	<input type="checkbox"/>	<input type="checkbox"/>	<input type="checkbox"/>
RINSE FLUID	_____	<input type="checkbox"/>	<input type="checkbox"/>	<input type="checkbox"/>	<input type="checkbox"/>
MACHINE OPERATION					
MACHINE RUNNING CORRECTLY?	<input type="checkbox"/> MULTIPLE CYCLES RUN, NO ISSUES				
CHEMICAL DOSAGE CORRECT?	<input type="checkbox"/> CORRECTLY FLOWING INTO MACHINE, NO FOAMING				
ALL OPERATIONS CORRECT?	<input type="checkbox"/> FILL LEVEL CORRECT, NO DRAINAGE ISSUES				
OPERATOR TRAINING					
ENSURE THAT THE CUSTOMER HAS BEEN GIVEN THE OPERATION MANUAL AND WALL CHART, AND IS AWARE OF THE IMPORTANCE OF BOTH USING AND CLEANING THE MACHINE CORRECTLY.					
START UP	<input type="checkbox"/>				
PRE-RINSE AND RACKING	<input type="checkbox"/> BETTER TO RINSE PLATES THAN REMOVE WASTE FROM MACHINE				
MACHINE USE AND CYCLE SELECTION	<input type="checkbox"/> USE LONG CYCLE WHERE POSSIBLE				
DRAINING THE MACHINE	<input type="checkbox"/> DRAIN THE MACHINE DAILY				
SHUT-DOWN AND DAILY CLEANING	<input type="checkbox"/> CHECK WASH ELEMENTS HAVE COOLED BEFORE CLEANING				
WEEKLY MAINTENANCE	<input type="checkbox"/> FULL MACHINE CLEAN INCLUDING WASH/RINSE ARMS				
PLANNED SERVICNG	<input type="checkbox"/> IMPORTANCE OF HAVING MACHINE SERVICED REGULARLY				

	°C
	kPa

INSTALLATION TROUBLESHOOTING

DOOR NOT CLOSING PROPERLY

- Level the dishwasher.

MACHINE NOT STARTING OR FILLING

- Ensure water supply to machine is turned on.
- Ensure power supply to machine is turned on.
- Check that the water inlet hose is not twisted or kinked.

CYCLE TAKING TOO LONG

- This machine ships with Thermostop enabled, which allows a cycle to be started at any time, even if the rinse water is not up to required temperature. To ensure a hygienic result, the wash cycle continues to run until the rinse temperature reaches the required 83°C. Then the machine will begin rinsing and complete the cycle.
- Check inlet water temperature is not too low as per our specifications.
- Check power supply, uprating will increase heating power and reduce recovery times.

POOR WASH RESULTS

- Check that there are adequate pre-rinse processes in place and staff use longer cycle options for more heavily soiled items.
- Ensure high quality non-foaming commercial dishwasher detergent has been connected at the correct dosage for your site, water quality and application. If uncertain, [consult a chemical specialist](#).
- Check that the wash arm is spinning freely and is not being obstructed.
- Ensure that the wash temperature is between 60°C and 65°C.
- Ensure that water quality is adequate. [Consult with a water specialist if not](#).

CHEMICAL RESIDUE AFTER CYCLE

- Check that nothing is obstructing the wash and rinse arms jets and/or rotation.
- Check detergent dosage is within the requirements.
- Check the rinse fluid dosage is not too high. If uncertain, [consult your chemical specialist](#).

DISHWASHER FOAMING

- Check that water pressure and flow rate to the machine are adequate. Insufficient water supply will effectively overdose the chemicals, and compromise the rinse performance.
- Ensure there is no other soap being transferred into the machine from the sink.
- Ensure high quality non-foaming commercial dishwasher detergent has been connected at the correct dosage for your site and application. If uncertain, please [consult a chemical specialist](#).
- Allow wash water to heat to at least 60°C prior to starting the first cycle as some commercial dishwasher chemical will foam at low temperatures.

OTHER UNITS HAVE WATER FILTERS AND/OR SCALE ISSUES

- Due to the high temperatures in dishwashers, scale will build up in the wash tank, on the arms and in the rinse tank. The incoming water should be treated. If uncertain, please [consult a water specialist](#).
- As with combi-ovens, high chloride levels will do irreversible damage to a number of the components inside a commercial dishwasher. The incoming water should be appropriately treated. If uncertain, please [consult a water specialist](#).

CYCLE TIMES NOT SUITABLE FOR ITEMS BEING WASHED

- Some sites may require longer or shorter cycles depending on the items being washed and the soil levels.
- Cycle lengths can be adjusted by a qualified service agent. For adjustment instructions refer to the adjustment section of the service manual for this model.

OPERATOR USE GUIDE

START

- Turn on at wall.
- Ensure Wash Pump Filter (2) and Drain Filter Basket (3) are firmly in place.
- Check the Scrap Tray (1) is in place and shut door.
- Shut door and turn the Selector Switch to any Cycle (I, II or III).
- Power light glows red and the machine will fill automatically.
- Once full, rinse heating starts.

OPERATION

- Use Selector Switch to choose cycle of I (40 seconds) , II (60 seconds) or III (90 seconds).
- Load items into the machine and shut door.
- Cycle light glows green while machine operates.
- When Cycle light goes out, the cycle is complete.

NOTE: The machine may be started while the rinse water is being heated – the machine will continue to run the wash cycle until the rinse water is up to temperature.

SHUT DOWN - EVERY NIGHT

- Open door and turn on Drain Switch to drain the wash tank.
- Once the Wash Tank is fully drained turn Drain Switch off.
- Turn Cycle Selector to 0 and turn off the power from the wall.
- Remove and rinse Scrap Tray (1), Wash Pump Filter (2) and Drain Filter Basket (3) before replacing back into the machine.

CLEANING – AT LEAST ONCE A WEEK

Remove, rinse and replace when machine has cooled down:

Scrap Tray	1
Wash Pump Filter	2
Drain Filter Basket	3
Wash Arms	4
Rinse Arms	5
Thumb Screws	6

Inspect and clear all jets in the upper and lower Wash/Rinse Arms using a small object such as a toothpick where necessary to remove any blockages prior to rinsing.

Check wash element once cool and clean if necessary.

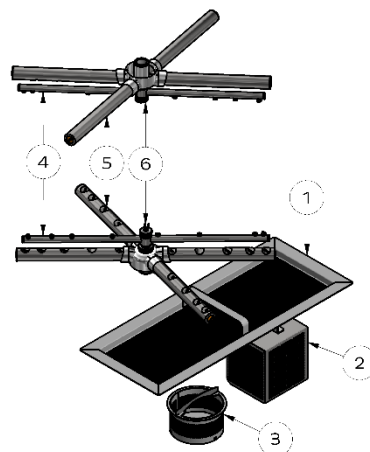
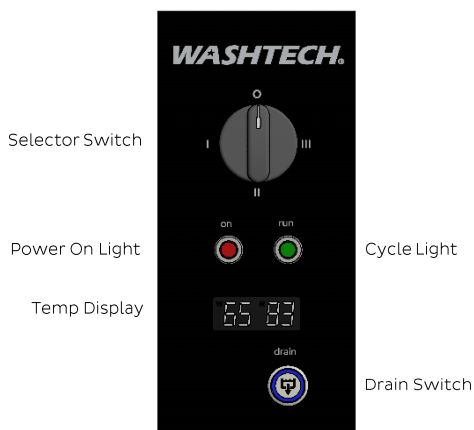

SUGGESTED BEST PRACTICE

Pre-rinse	Scrape and/or rinse trays, plates & glasses in cool water.
Chemical	Use a good quality non foaming commercial detergent and drying agent – do not use domestic detergents which will cause the wash tank to foam. Do not use domestic tablets or excessively chlorinated chemicals.
Servicing	A dishwasher technician should service this machine the lesser of every 6 months or 15,000 cycles.

OPERATOR TROUBLESHOOTING

ISSUE	CAUSE										
	POOR PRE-SCRAPING	CARRY OVER OF SOAP FROM SINK	OVERLOADING RACKS	INADEQUATE MACHINE CLEANING	INSUFFICIENT WATER PRESSURE/FLOW	INSUFFICIENT WASH TEMPERATURE	WASH/RINSE JETS BLOCKED	WASH/RINSE ARMS NOT ROTATING	DETERGENT DOSAGE LOW/HIGH*	RINSE FLUID DOSAGE LOW/HIGH*	POOR WATER QUALITY**
DISHES NOT CLEAN	●		●	●			●	●	●		■
STAINING	●						●	■	●		■
FOAMING		●		■	●	●			■	■	
PROTEIN BLOOM	■		■	●			■	■	■		
DIRTY MACHINE	●			●			■	■	■		■
FOOD RESIDUE ON WARE	■		●	■			■	■	●		
FILM/SPOTS ON WARE			■	■	●		■	●	●		■
DETERGENT RESIDUE					●		■	●	●		
GREASY FILM/NO FIZZ			■							●	■
HIGH DETERGENT USE				■					●		
HIGH RINSE FLUID USE				■						●	
WET WASHWARE			●	■		●				●	
SCALE BUILD UP IN MACHINE				●					■		●
FILTERS ON OTHER EQUIPMENT											●

- Likely cause
- Possible cause

* For issues most likely due to incorrect chemical dosages or other chemical issues, we recommend you consult your chemical supplier and/or a local chemical expert prior to calling in a dishwasher technician.

** For issues that are likely due to poor water quality (scale building up, filters being required on other kitchen equipment etc.), we recommend you consult a local water specialist prior to calling in a dishwasher technician.

IF PROBLEMS PERSIST CONTACT YOUR SERVICE PROVIDER

SCHEMATIC DIAGRAM

XL SERIES-3

- Part #: 010195
- Date: 26/02/2024
- Version: 1-B

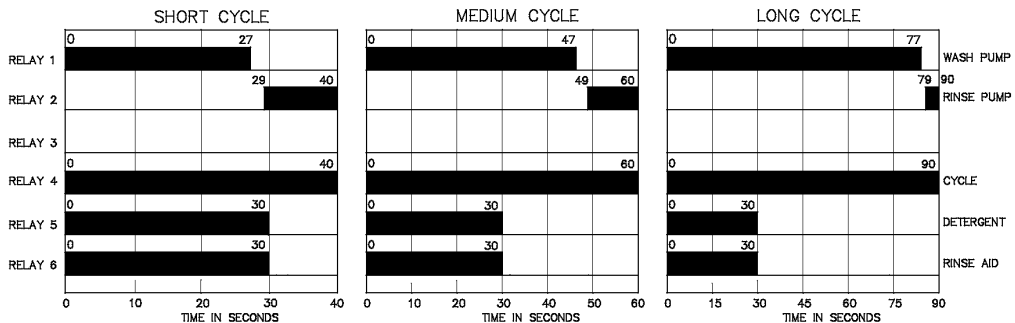
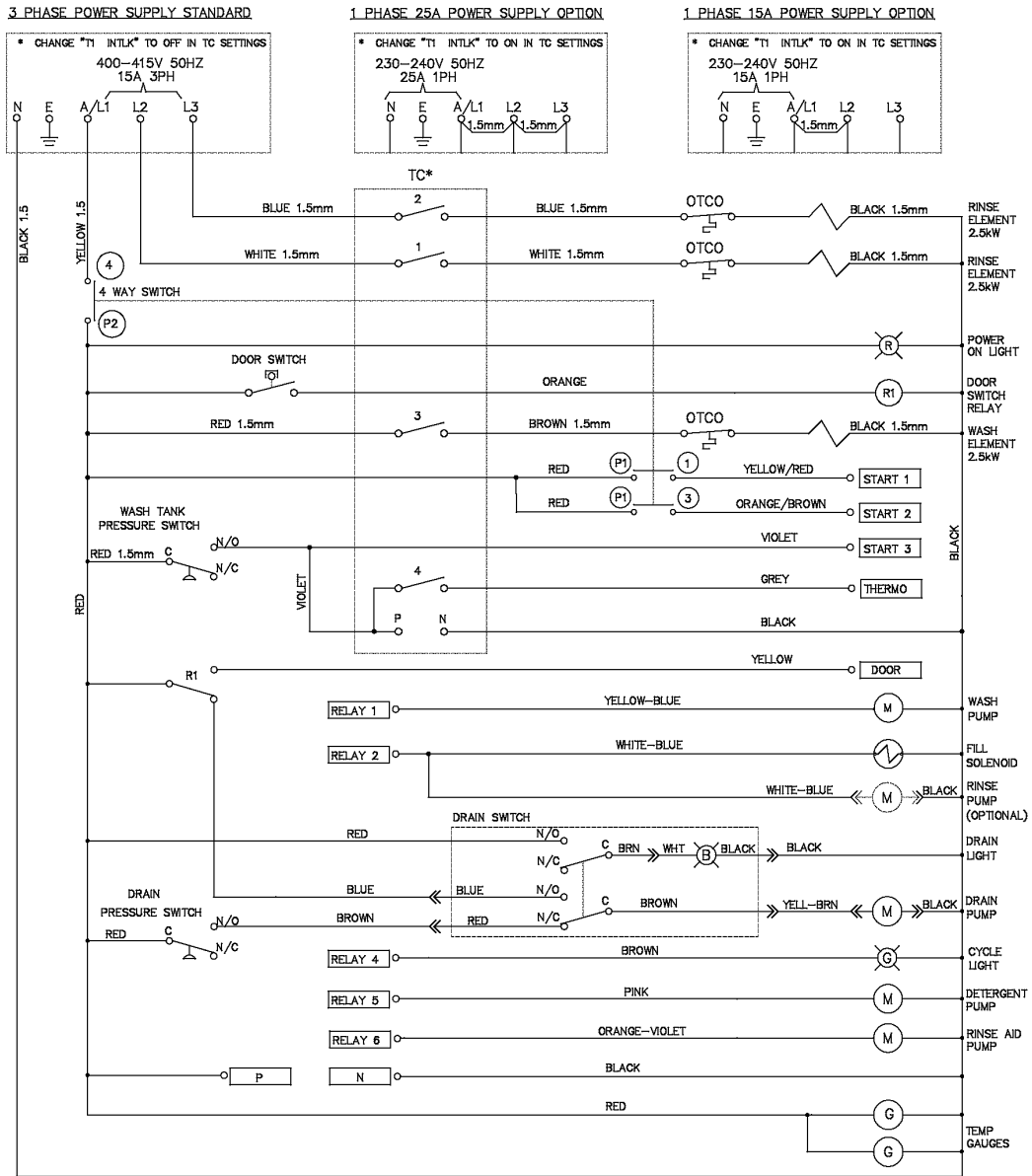

ACCESSORIES

XL SERIES-3

- Part #: XL3 ACS
- Date: 22/06/2023
- Version: 1-A

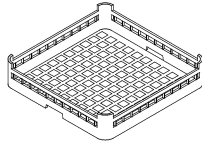

600 70029
CUPRACK CB 500mm X 75mm high

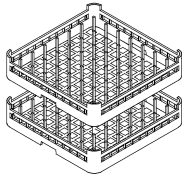

600 70028
DISHRACK P12/18 500mm 18 DISH



C660503
CUTLERY CONTAINER G

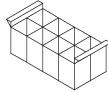

C660508
CUTLERY BASKET CP8 for 500mm

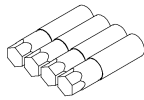

600 90154
SS LEG 63 D x 225 - 325mm x M12

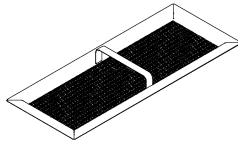

328 10003
M2 SCRAP TRAY ASSEMBLY



600 90080
2M S/S HOSE

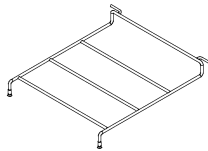

303 10010
XP(4) RACK SLIDE ASSEMBLY

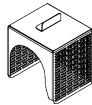

304 10026
WASH INLET FILTER



400 10437
DRAIN INLET FILTER

SPARE PARTS

DESCRIPTION

PART

CABINET & DOOR

- Control Panel 400 20428
- Control Panel Label 400 70286
- Front Panel 303 24008
- Lower Rear Panel 303 24004
- Door 304 10007
- Door Handle 304 10037
- Door Springs 326 30019

CONTROLS & INDICATOR

- Cycle Light 600 30656
- Door Reed Switch 600 30183
- Drain Switch 600 30617
- Knob 4 Position 600 30524
- Loom for Temperature Display 600 30646
- Power Light 600 30657
- Power Relay 600 30223
- Pressure Switch Drain 600 30478
- Pressure Switch Wash 600 30479
- Switch 4 Position 600 30269
- Temperature Controller 600 30640
- Temperature Display 600 30643
- Terminal Strip 5 Way 3229
- Timer Electronic 600 30513

HEATING COMPONENTS

- Over Temperature Thermostat 600 30088
- Rinse Element 5 kW 600 30497
- Rinse Tank Assembly 303 14017
- Wash Element 2.5 kW 600 30226

HOSES

- Detergent Hose 600 30148
- Pressure Switch Hose 3067
- Rinse Hose 600 60073
- Wash Pump Inlet Hose C200359
- Wash Pump Outlet Hose 61941
- Lower Wash Tee Hose 6195
- Drain hose 600 60105
- Drain Pump Inlet Hose 6197
- Drain Pump Outlet Hose 6196

SPARE PARTS

DESCRIPTION

PART

PUMPS & SOLENOIDS

• Detergent Pump	600 30526
• Detergent Squeeze Tube	600 30134
• Rinse Aid Pump	600 30480
• AVB	600 60053
• Solenoid Valve	3342
• Wash Pump	600 30412
• Rinse Pump (optional)	600 30400
• Drain Pump	600 60102

WASH TANK COMPONENTS

• Drain Filter Basket Assembly	400 10437
• Rack Slide Assembly	303 10010
• Rinse Arm Assembly	400 10239
• Rinse Arm Thumbscrew	C261004
• Rinse Arm Thumbscrew Spring	C450218
• Scrap Tray	328 10003
• Wash Arm Assembly	400 10077
• Wash Arm Locknut	C280409
• Wash Pump Inlet Filter	304 10026
• Wash & Rinse Spindle	400 30362

Information supplied in this manual is copyright. No part of this work may be reproduced or copied in any form or by any means, electronic or mechanical without the express permission of the author/publisher



All Washtech products are designed and manufactured using the internationally recognised ISO9001 quality management system, covering design, manufacture and final inspection, ensuring consistently high quality.

Washtech continually seeks to develop and improve our products, thus Washtech reserves the right to change specifications and design without prior notice.



Distributed in Australia by:
Moffat Limited

70 Springvale Road
Mulgrave, Victoria 3170
AUSTRALIA

Ph: 1300 269 801

moffat.com.au



Manufactured in New Zealand by:
Washtech Limited

414 Rosebank Road
Avondale, Auckland 1026
NEW ZEALAND

washtech.com.au

©2021 Washtech Limited.
All rights reserved.

an Ali Group Company



The Spirit of Excellence

