

# WASHTECH®

## OPERATOR USE

# XG

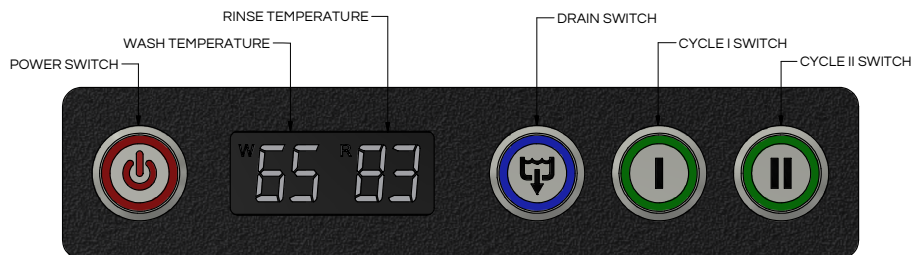

### START

- Turn on at wall.
- Ensure the Wash / Drain Filter Basket (1) is in place and shut the door.
- Press the Power switch, the switch will glow red and the machine will fill automatically.

### OPERATION

- Load rack into the machine and shut door.
- Press Start button to start a cycle.
- Cycle button glows green while machine operates.
- When Cycle light goes out, the cycle is complete.

NOTE: The machine may be started while the rinse water is being heated – the machine will continue to run the wash cycle until the rinse water is up to temperature.

### SHUT DOWN - EVERY NIGHT

- Open the door, press the Drain switch and leave the door open.
- Allow to drain for approximately 1 minute or until the tank is empty.
- Turn the Drain and then the Power switches off.
- Once the machine has cooled down, clean the wash tank, then remove and rinse Wash / Drain Filter Basket (1)
- Check and clear any waste from inside the drain sump.
- Replace Wash / Drain Filter back into machine.

### CLEANING - AT LEAST ONCE A WEEK

- Remove, rinse and replace when machine has cooled down:

Wash / Drain Filter Basket	1
Wash / Rinse Arms	2
Wash / Rinse Arm Thumbscrew	3
- Unscrew thumbscrew (3) to remove Wash/Rinse Arm.
- Inspect Arm and ensure that all jets are clear.
- Use a small object (e.g. toothpick) where necessary to remove any blockages.
- Check wash element once cool and clean if necessary.

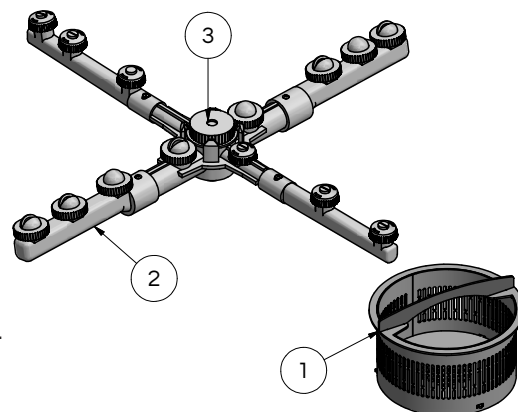

### SUGGESTED BEST PRACTICE

- |           |  |
|-----------|--|
| Pre-rinse | Scrape and/or rinse glasses in cool water.   |
| Chemical  | Use a good quality non foaming commercial detergent and drying agent – do not use domestic detergents which will cause the machine to foam.<br>Do not use domestic tablets or excessively chlorinated chemicals. |
| Servicing | A dishwasher technician should service this machine at least every 6 months or 15k cycles.   |

# WASHTECH®

## TROUBLESHOOTING

# XG

ISSUE	CAUSE										
	POOR PRE-SCRAPING	CARRY OVER OF SOAP FROM SINK	OVERLOADING RACKS	INADEQUATE MACHINE CLEANING	INSUFFICIENT WATER PRESSURE/FLOW	INSUFFICIENT WASH TEMPERATURE	WASH/RINSE JETS BLOCKED	WASH/RINSE ARMS NOT ROTATING	DETERGENT DOSAGE LOW/HIGH*	RINSE FLUID DOSAGE LOW/HIGH*	POOR WATER QUALITY**
DISHES NOT CLEAN	●		●	●			●	●	●		■
STAINING	●						●	■	●		■
FOAMING		●		■	●	●			■	■	
PROTEIN BLOOM	■		■	●			■	■	■		
DIRTY MACHINE	●			●			■	■	■		■
FOOD RESIDUE ON WASHWARE	■		●	■			■	■	●		
FILM / SPOTS ON WASHWARE			■	■	●		■	●	●		■
DETERGENT RESIDUE					●		■	●	●		
GREASY FILM / NO FIZZ IN DRINKS			■							●	■
HIGH DETERGENT USAGE				■					●		
HIGH RINSE FLUID USAGE				■						●	
WET WASHWARE			●	■		●				●	
SCALE BUILD UP IN MACHINE				■					■		●
FILTERS NEEDED ON OTHER EQUIPMENT											●

● Likely Cause of Issue      ■ Possible Cause of Issue

\* For issues most likely due to incorrect chemical dosages or other chemical issues, we recommend you consult your chemical supplier and/or a local chemical expert prior to calling in a dishwasher technician.

\*\* For issues that are likely due to poor water quality (scale building up, filters being required on other kitchen equipment etc.), we recommend you consult a local water specialist prior to calling in a dishwasher technician.

### IF PROBLEMS PERSIST CONTACT YOUR SERVICE PROVIDER

Service 1300 264 217  
 Customer Service 1300 269 801  
 Washtech XG Series-5 Jan-24

Distributed in Australia by:

