

## M2C



### START

- If machine is not displaying Standby, turn on at wall
- Check the Upstand (1), Filter (2) and Scrap Tray (3) are in place and shut door
- Press Power button for 3 seconds to turn machine on and begin the fill cycle

### OPERATION

- Select cycle using Up/Down buttons (use the Heavy cycle whenever possible)
- Press Start button (once this is Green or Orange) to begin washing
- Timer counts down to 00 then resets after door is opened

### START BUTTON COLOURS

- |  |  |  |                             |
|--|--|--|-----------------------------|
|  | White = machine is filling               |  | Purple = door is open       |
|  | Red = cycle is running                   |  | Orange = machine is heating |
|  | Green = rinse water is up to temperature |  |                             |

NOTE: The machine may be started while Orange light is on and while rinse water is being heated and the timer will pause at 22 seconds until rinse water is up to 83 degrees

### SHUT DOWN – EVERY NIGHT

- Remove drain Upstand (1) and shut door
- Select Drain cycle via Up/Down buttons and press Start button
- When Drain cycle is finished after 100 seconds, clean the tank then remove and rinse Scrap Tray (3) and Filter (2) before replacing back in machine along with Upstand (1)

### CLEANING – AT LEAST ONCE A WEEK

Remove, rinse and replace:

|            |   |
|------------|---|
| Upstand    | 1 |
| Filter     | 2 |
| Scrap Tray | 3 |
| Rinse Arm  | 4 |
| Wash Arm   | 5 |

Inspect and clear all jets in the Wash/Rinse Arm using a small object such as a toothpick where necessary to remove any blockages prior to rinsing

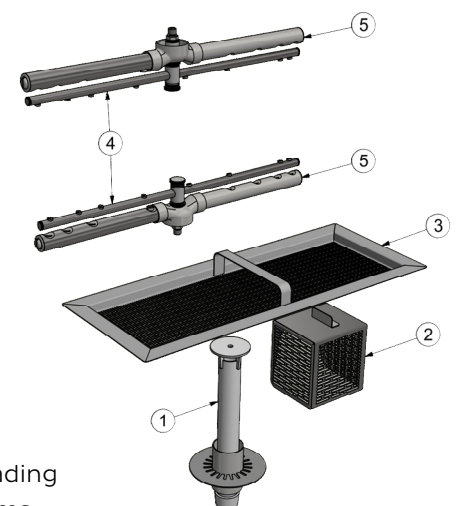

### SUGGESTED BEST PRACTICE

- |              |   |
|--------------|---|
| Cutlery      | Stack with handles or sharp blades down and avoid overloading   |
| Light Items  | Ensure these are secured or weighted down by heavier items  |
| Pre-rinse    | Scrape and/or rinse plates & glasses in cool water  |
| Chemical     | Chemicals can be adjusted and primed via the control panel, please review the operator manual for full instructions                                 |
|              | Use good quality non foaming commercial detergent and drying agent – do not use domestic detergent which will cause the machine to foam             |
| Wash results | If wash results are deteriorating, check that you have haven't run out of detergent and that the wash/rinse arms are clean and free of obstructions |

# M2C OPERATOR TROUBLESHOOTING

| Issue                      | Cause             |                              |                   |                   |                              |                                 |                   |                           |                            |                              |                      |                              |
|----------------------------|-------------------|------------------------------|-------------------|-------------------|------------------------------|---------------------------------|-------------------|---------------------------|----------------------------|------------------------------|----------------------|------------------------------|
|                            | POOR PRE-SCRAPING | CARRY OVER OF SOAP FROM SINK | OVERLOADING RACKS | POOR MACHINE CARE | DRAIN UPSTAND NOT PLUGGED IN | JETS BLOCKED OR ARMS OBSTRUCTED | RINSE NOT WORKING | WATER SUPPLY PRESSURE LOW | DETERGENT DOSAGE LOW/HIGH* | RINSE FLUID DOSAGE LOW/HIGH* | POOR WATER QUALITY** | RINSE TEMPERATURE LOW <75 °C |
| DISHES NOT CLEAN           | ●                 |                              | ●                 | ●                 |                              | ●                               | ●                 | ●                         | ●                          |                              | ●                    | ●                            |
| STAINING                   | ●                 |                              |                   |                   |                              | ●                               | ●                 | ●                         | ●                          |                              | ●                    | ●                            |
| FOAMING                    |                   | ●                            |                   | ●                 |                              |                                 | ●                 |                           | ●                          | ●                            |                      |                              |
| PROTEIN BLOOM              | ●                 |                              | ●                 | ●                 |                              | ●                               | ●                 | ●                         | ●                          |                              |                      | ●                            |
| DIRTY MACHINE              | ●                 |                              | ●                 | ●                 |                              | ●                               | ●                 | ●                         | ●                          |                              | ●                    | ●                            |
| FOOD RESIDUE ON WARE       | ●                 |                              | ●                 | ●                 |                              | ●                               |                   | ●                         | ●                          |                              | ●                    | ●                            |
| FILM/SPOTS ON WARE         |                   |                              | ●                 | ●                 |                              | ●                               | ●                 | ●                         | ●                          |                              | ●                    | ●                            |
| DETERGENT RESIDUE          |                   |                              |                   |                   |                              | ●                               | ●                 | ●                         | ●                          |                              |                      |                              |
| GREASY FILM/NO FIZZ        |                   |                              | ●                 |                   |                              |                                 | ●                 | ●                         |                            | ●                            | ●                    |                              |
| HIGH DETERGENT USE         |                   |                              |                   | ●                 | ●                            |                                 |                   | ●                         | ●                          |                              |                      |                              |
| HIGH RINSE FLUID USE       |                   |                              |                   | ●                 |                              |                                 |                   | ●                         |                            | ●                            |                      |                              |
| WET WASHWARE               |                   |                              | ●                 | ●                 |                              |                                 |                   | ●                         |                            | ●                            |                      |                              |
| SCALE BUILD UP IN MACHINE  |                   |                              |                   | ●                 |                              |                                 |                   |                           |                            |                              | ●                    |                              |
| FILTERS ON OTHER EQUIPMENT |                   |                              |                   |                   |                              |                                 |                   |                           |                            |                              | ●                    |                              |

● Likely cause      ● Possible cause

\* For issues most likely due to incorrect chemical dosages or other chemical issues, we recommend you consult your chemical supplier and/or a local chemical expert prior to calling in a dishwasher technician.

\*\* For issues that are likely due to poor water quality (scale building up, filters being required on other kitchen equipment etc.), we recommend you consult a local water specialist prior to calling in a dishwasher technician.

\*\*\* To reset the machine after an error message has been displayed, simply turn the machine OFF and then back ON again. The machine will log the error for future reference.

**IF PROBLEMS PERSIST CONTACT MOFFAT SERVICE ON 1300 264 217**