

Dell PowerEdge R830

Owner's Manual

Notes, cautions, and warnings

 **NOTE:** A NOTE indicates important information that helps you make better use of your product.

 **CAUTION:** A CAUTION indicates either potential damage to hardware or loss of data and tells you how to avoid the problem.

 **WARNING:** A WARNING indicates a potential for property damage, personal injury, or death.

Chapter 1: Dell PowerEdge R830 overview.....	8
Supported configurations for the PowerEdge R830 system.....	8
Front panel	10
2.5 inch hard drive chassis.....	10
LCD panel.....	12
Back panel.....	14
Diagnostic indicators on the front panel.....	15
Hard drive indicator codes.....	17
NIC indicator codes.....	18
Power supply unit indicator codes.....	18
Locating service tag of your system.....	20
Chapter 2: Documentation resources.....	21
Chapter 3: Technical specifications.....	24
System dimensions.....	24
Chassis weight.....	25
Processor specifications.....	25
PSU specifications.....	25
System battery specifications.....	25
Expansion bus specifications.....	25
Memory specifications.....	26
Drive specifications.....	26
Hard drives.....	26
Optical drive.....	26
Ports and connectors specifications.....	26
USB ports.....	26
NIC ports.....	26
Serial connector.....	27
VGA ports.....	27
Internal Dual SD Module.....	27
Video specifications.....	27
Environmental specifications.....	27
Particulate and gaseous contamination specifications	28
Standard operating temperature.....	29
Expanded operating temperature.....	29
Chapter 4: Initial system setup and configuration.....	31
Setting up your system.....	31
iDRAC configuration.....	31
Options to set up iDRAC IP address.....	31
Options to install the operating system.....	32
Methods to download firmware and drivers.....	32

Chapter 5: Pre-operating system management applications.....	34
Options to manage the pre-operating system applications.....	34
System Setup.....	34
Viewing System Setup.....	35
System Setup details.....	35
System BIOS.....	35
iDRAC Settings utility.....	59
Device Settings.....	60
Dell Lifecycle Controller.....	60
Embedded systems management.....	60
Boot Manager.....	60
Viewing Boot Manager.....	61
Boot Manager main menu.....	61
PXE boot.....	62
Chapter 6: Installing and removing system components.....	63
Safety instructions.....	63
Before working inside your system.....	64
After working inside your system.....	64
Recommended tools.....	64
Front bezel (optional).....	65
Removing the optional front bezel.....	65
Installing the optional front bezel.....	66
System cover.....	66
Removing the system cover.....	66
Installing the system cover.....	67
Inside the system.....	69
Processor expansion module (optional).....	70
Removing the processor expansion module.....	70
Installing the processor expansion module.....	72
Cooling shroud.....	76
Removing the cooling shroud.....	76
Installing the cooling shroud.....	77
Cooling fans.....	78
Removing a cooling fan.....	79
Installing a cooling fan.....	80
Cooling fan assembly	80
Removing the cooling fan assembly.....	80
Installing the cooling fan assembly.....	81
System memory.....	83
General memory module installation guidelines.....	85
Mode-specific guidelines.....	85
Sample memory configurations.....	86
Removing memory modules.....	91
Installing memory modules.....	92
Processors and heat sinks.....	94
Removing a heat sink.....	94
Removing a processor.....	95

Installing a processor.....	99
Installing a heat sink.....	101
Power supply units.....	102
Hot spare feature.....	103
Removing the power supply unit blank.....	103
Installing the power supply unit blank.....	104
Removing an AC power supply unit.....	105
Installing an AC power supply unit.....	106
Integrated storage controller card.....	107
Removing the integrated storage controller card.....	107
Installing the integrated storage controller card.....	108
Expansion cards and expansion card riser.....	110
Expansion card installation guidelines.....	110
Removing expansion card risers.....	111
Installing expansion card risers.....	115
Removing an expansion card from expansion card riser 1.....	118
Installing an expansion card into expansion card riser 1.....	120
Removing an expansion card from expansion card riser 2.....	121
Installing an expansion card into expansion card riser 2.....	123
Removing an expansion card from the expansion card riser 3.....	124
Installing an expansion card into expansion card riser 3.....	126
IDSDM	128
Removing an internal SD card.....	129
Installing an internal SD card.....	130
Removing the optional internal dual SD module.....	131
Installing the optional internal dual SD module	132
Network daughter card.....	133
Removing the network daughter card	133
Installing the network daughter card.....	135
Internal USB memory key (optional).....	136
Replacing the optional internal USB memory key.....	136
System battery	137
Replacing the system battery.....	137
Hard drives.....	139
Removing a hot swappable hard drive or solid state drive.....	139
Installing a hot swappable hard drive or solid state drive.....	140
Removing a 2.5-inch hard drive blank.....	141
Installing a 2.5-inch hard drive blank.....	142
Removing a hard drive or a solid state drive from a hard drive carrier.....	143
Installing a hard drive or solid state drives into a hard drive carrier.....	143
Optical drive (optional).....	144
Removing the optical drive.....	144
Installing the optical drive.....	145
Removing the slim optical drive blank.....	146
Installing the slim optical drive blank.....	147
Hard drive backplane.....	148
Removing the hard drive backplane	148
Installing the hard drive backplane.....	153
Control panel.....	154
Removing the control panel	154

Installing the control panel	157
System board.....	159
Removing the system board.....	159
Installing the system board.....	161
Trusted Platform Module.....	163
Installing the Trusted Platform Module.....	164
Initializing the TPM for BitLocker users.....	165
Initializing the TPM for TXT users.....	165
Chapter 7: Using system diagnostics.....	166
Dell Embedded System Diagnostics.....	166
When to use the Embedded System Diagnostics.....	166
Running the Embedded System Diagnostics from Boot Manager.....	166
Running the Embedded System Diagnostics from the Dell Lifecycle Controller.....	166
System diagnostic controls.....	167
Chapter 8: Jumpers and connectors.....	168
System board jumper settings.....	168
System Board Connectors.....	169
Disabling forgotten password.....	171
Chapter 9: Troubleshooting your system.....	173
Troubleshooting system startup failure.....	173
Troubleshooting external connections.....	173
Troubleshooting the video subsystem.....	174
Troubleshooting a USB device.....	174
Troubleshooting iDRAC Direct - USB XML configuration.....	175
Troubleshooting iDRAC Direct - Laptop connection.....	175
Troubleshooting a serial input and output device.....	176
Troubleshooting a NIC.....	176
Troubleshooting a wet system.....	177
Troubleshooting a damaged system.....	178
Troubleshooting the system battery.....	178
Troubleshooting power supply units.....	179
Troubleshooting power source problems.....	179
Troubleshooting power supply unit problems.....	179
Troubleshooting cooling problems.....	180
Troubleshooting cooling fans.....	180
Troubleshooting system memory.....	181
Troubleshooting an internal USB key.....	182
Troubleshooting a micro SD card.....	183
Troubleshooting an optical drive.....	183
Troubleshooting a tape backup unit.....	184
Troubleshooting a drive or SSD.....	184
Troubleshooting a storage controller.....	185
Troubleshooting expansion cards.....	186
Troubleshooting processors.....	187
System messages.....	187
Warning messages.....	187

Diagnostic messages.....	187
Alert messages.....	187
Chapter 10: Getting help.....	188
Contacting Dell EMC.....	188
Documentation feedback.....	188
Accessing system information by using QRL.....	188
Quick Resource Locator for R830.....	189

Dell PowerEdge R830 overview

The Dell PowerEdge R830 is a 2U rack system with an 8-drive or 16-drive bay chassis and supports up to:

- Four Intel Xeon E5-4600 v4 processors
- 48 DIMMs
- 16 hard drives or solid-state drives
-  **NOTE:** Your system supports only hot swappable hard drives.
- Two power supply units

Topics:

- [Supported configurations for the PowerEdge R830 system](#)
- [Front panel](#)
- [Back panel](#)
- [Diagnostic indicators on the front panel](#)
- [Locating service tag of your system](#)

Supported configurations for the PowerEdge R830 system

The Dell PowerEdge R830 system supports the following configurations:

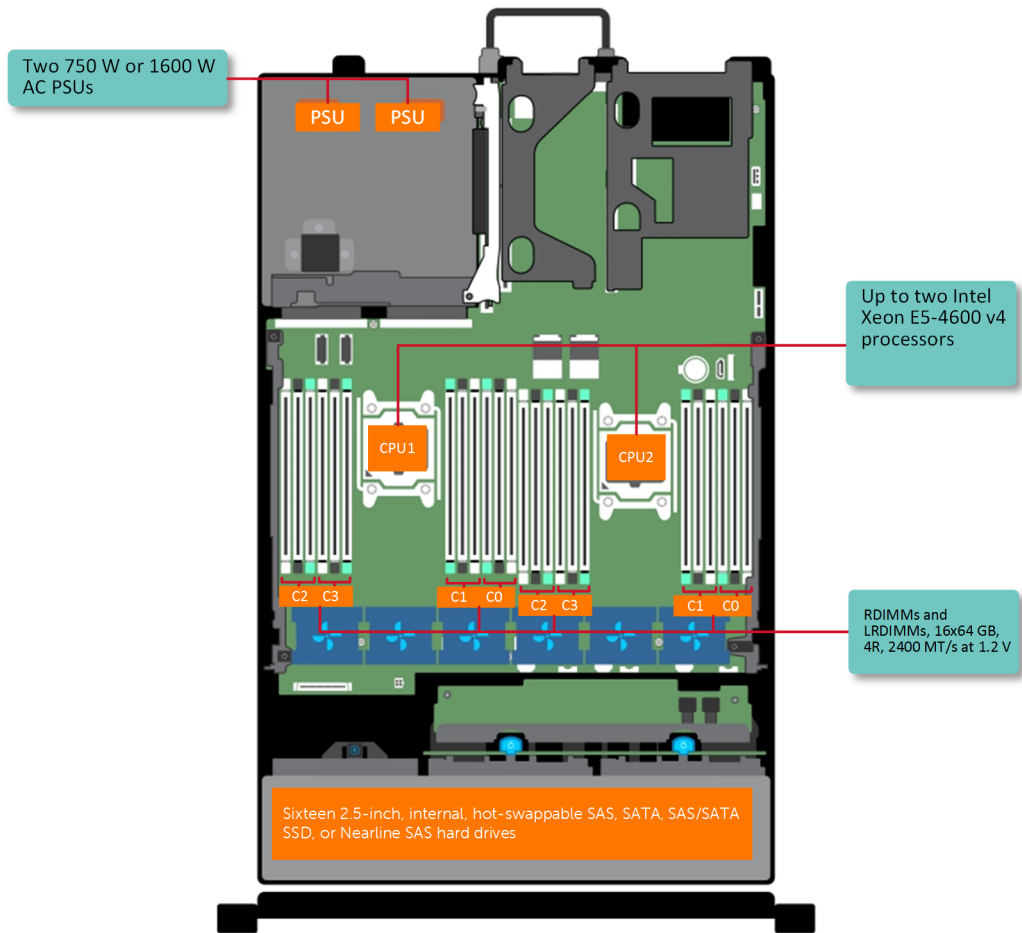

Figure 1. Supported configurations for a two processor PowerEdge R830 system

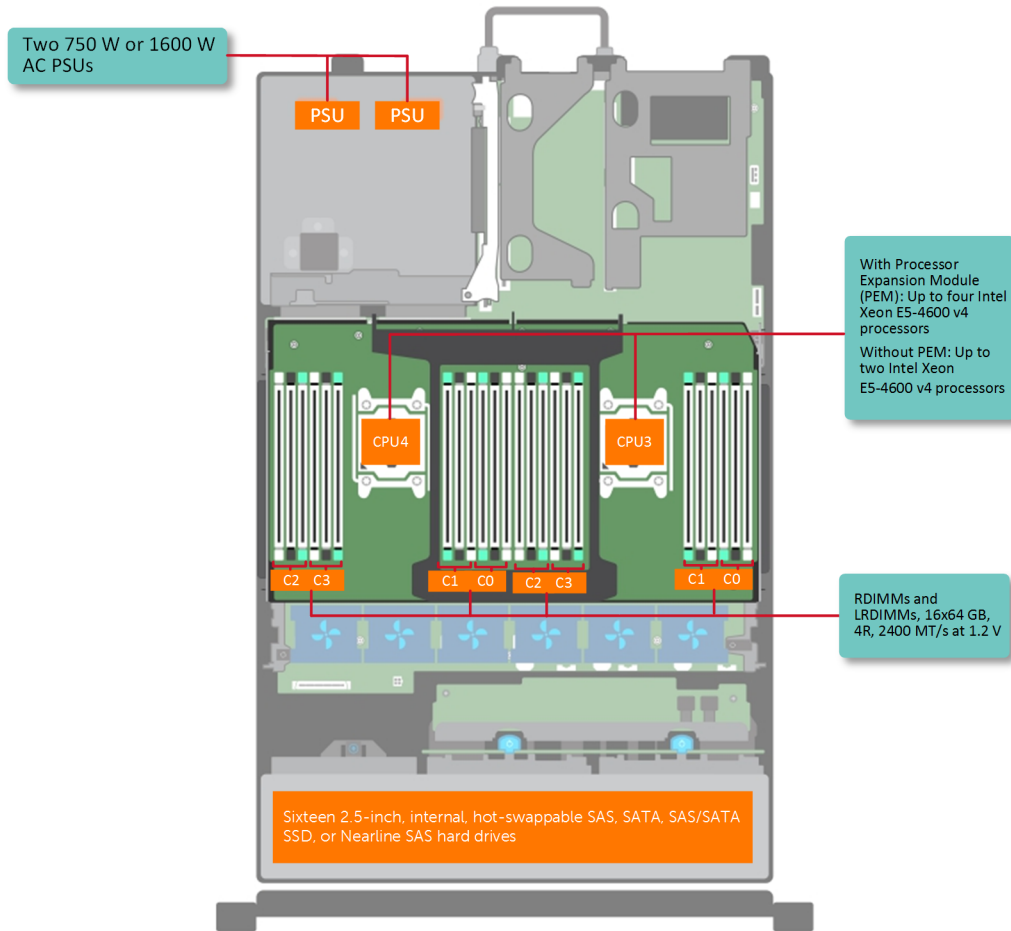

Figure 2. Supported configurations for a four processor PowerEdge R830 system

Front panel

The front panel provides access to the features available on the front of the server, such as the power button, NMI button, system identification tag, system identification button, and USB and VGA ports. The diagnostic LEDs or the LCD panel is prominently located on the front panel. The hot swappable hard drives are accessible from the front panel.

2.5 inch hard drive chassis

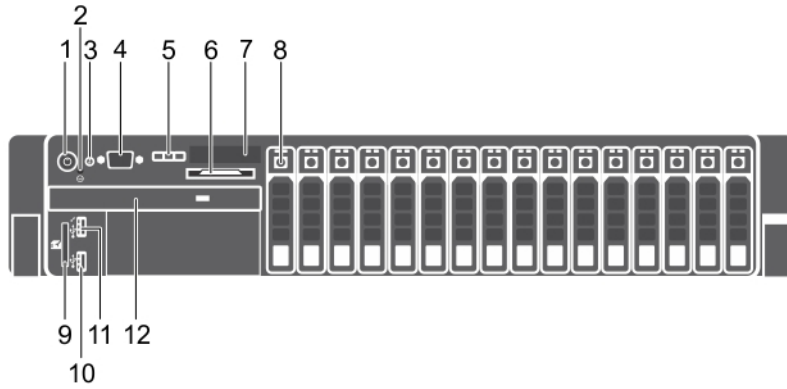





Figure 3. Front panel features (2.5-inch hard drive chassis)

- | | |
|--------------------------------------|--------------------|
| 1. Power button | 2. NMI button |
| 3. System identification button | 4. Video connector |
| 5. LCD menu buttons | 6. Information tag |
| 7. LCD panel | 8. Hard drives |
| 9. vFlash media card slot | 10. USB port |
| 11. USB management port/iDRAC Direct | 12. Optical drive |

Table 1. Front panel features (2.5-inch hard drive chassis)

Item	Indicator, button, or connector	Icon	Description
1	Power button		Press the power button to turn the system on or off. The indicator on the button indicates if the system is on or off. NOTE: To gracefully shut down an ACPI-compliant operating system, press the power button.
2	NMI button		Press the NMI button to troubleshoot software and device driver errors when running certain operating systems. Use the end of a paper clip to press the NMI button. NOTE: Use the NMI button only if directed to do so by qualified support personnel or by the operating system documentation.
3	System identification button		Press the system ID button: <ul style="list-style-type: none"> To locate a particular system within a rack. To turn the system ID on or off. To reset iDRAC, press and hold the button for more than 15 seconds. NOTE: <ul style="list-style-type: none"> To reset iDRAC using system ID, ensure that the system ID button is enabled in the iDRAC setup. If the system stops responding during POST, press and hold the system ID button (for more than five seconds) to enter the BIOS progress mode.
4	Video connector		Use the video/VGA port to connect a display to the system. For more information about the supported video/VGA port, see the Technical specifications section.
5	LCD menu buttons		Press the LCD menu buttons to navigate the control panel LCD menu.

Table 1. Front panel features (2.5-inch hard drive chassis) (continued)

Item	Indicator, button, or connector	Icon	Description
6	Information tag		Displays system information such as service tag, NIC, and MAC address. i NOTE: The information tag is a slide-out label panel.
7	LCD panel		Displays system ID, status information, and system error messages. For more information, see the LCD panel section.
8	Hard drives		For information about the supported hard drives, see the Technical specifications section.
9	vFlash media card slot		Use the vFlash media card slot to insert a vFlash media card.
10	USB 2.0 port		Use the USB 2.0 port to connect USB devices to the system. This port is 4-pin, USB 2.0 compliant.
11	USB management port/iDRAC Direct		Use the USB management port/iDRAC Direct port to connect USB devices to the system or provide access to the iDRAC Direct features. The USB management port is USB 2.0 compliant. For more information, see the Integrated Dell Remote Access Controller User's Guide at Dell.com/idracmanuals .
12	Optical drive (optional)		For information about the supported optical drive, see the Technical specifications section.

Related references

- [Technical specifications](#) on page 24
- [Safety instructions](#) on page 63

Related tasks

- [Removing the system cover](#) on page 66

LCD panel

The LCD panel of your system provides system information, status, and error messages to indicate if the system is functioning correctly or if the system needs attention. For more information about error messages, see the *Dell Event and Error Messages Reference Guide* at Dell.com/openmanagemanuals > **OpenManage software**.

- The LCD backlight turns blue during normal operating conditions.
- When the system needs attention, the LCD turns amber, and displays an error code followed by descriptive text.
i **NOTE:** If the system is connected to a power source and an error is detected, the LCD turns amber regardless of whether the system is turned on or off.
- The LCD backlight is turned off when the system is in standby mode and can be turned on by pressing either the Select, Left, or Right button on the LCD panel.
- The LCD backlight remains off if LCD messaging is turned off using the iDRAC utility, the LCD panel, or other tools.

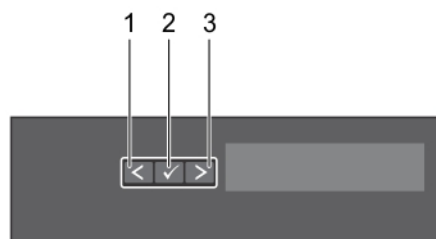

Figure 4. LCD panel features



Table 2. LCD panel features

Item	Button	Description
1	Left	Moves the cursor back in one-step increments.
2	Select	Selects the menu item highlighted by the cursor.
3	Right	<p>Moves the cursor forward in one-step increments.</p> <p>During message scrolling:</p> <ul style="list-style-type: none"> ● Press and hold the button to increase scrolling speed. ● Release the button to stop. <p>NOTE: The display stops scrolling when the button is released. After 45 seconds of inactivity, the display starts scrolling.</p>

Viewing Home screen

The **Home** screen displays user-configurable information about the system. This screen is displayed during normal system operation when there are no status messages or errors. When the system turns off and there are no errors, LCD enters the standby mode after five minutes of inactivity. Press any button on the LCD to turn it on.

Steps

1. To view the **Home** screen, press one of the three navigation buttons (Select, Left, or Right).
2. To navigate to the **Home** screen from another menu, complete the following steps:
 - a. Press and hold the navigation button till the up arrow  is displayed.
 - b. Navigate to the  using the up arrow .
 - c. Select the **Home** icon.
 - d. On the **Home** screen, press the **Select** button to enter the main menu.

Setup menu

NOTE: When you select an option in the Setup menu, you must confirm the option before proceeding to the next action.

Option	Description
iDRAC	Select DHCP or Static IP to configure the network mode. If Static IP is selected, the available fields are IP , Subnet (Sub) , and Gateway (Gtw) . Select Setup DNS to enable DNS and to view domain addresses. Two separate DNS entries are available.
Set error	<p>Select SEL to view LCD error messages in a format that matches the IPMI description in the SEL. This enables you to match an LCD message with an SEL entry.</p> <p>Select Simple to view LCD error messages in a simplified user-friendly description. For more information about error messages, see the <i>Dell Event and Error Messages Reference Guide</i> at Dell.com/openmanagemanuals > OpenManage software.</p>
Set home	Select the default information to be displayed on the Home screen. See View menu section for the options and option items that can be set as the default on the Home screen.

Related references

[View menu](#) on page 13

View menu

NOTE: When you select an option in the View menu, you must confirm the option before proceeding to the next action.

Option	Description
iDRAC IP	Displays the IPv4 or IPv6 addresses for iDRAC8. Addresses include DNS (Primary and Secondary) , Gateway, IP , and Subnet (IPv6 does not have Subnet).
MAC	Displays the MAC addresses for iDRAC , iSCSI , or Network devices.
Name	Displays the name of the Host , Model , or User String for the system.
Number	Displays the Asset tag or the Service tag for the system.
Power	Displays the power output of the system in BTU/hr or Watts. The display format can be configured in the Set home submenu of the Setup menu.
Temperature	Displays the temperature of the system in Celsius or Fahrenheit. The display format can be configured in the Set home submenu of the Setup menu.

Back panel

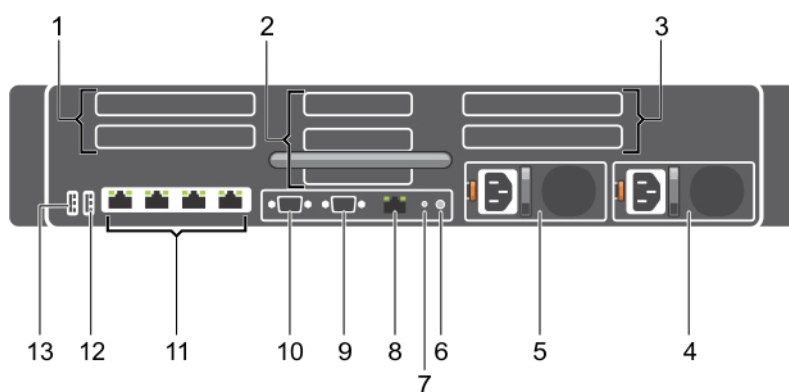

Figure 5. Back panel features

- | | |
|--|--|
| 1. Full-height PCIe expansion card slot on Riser 1 (2) | 2. Half-height PCIe expansion card slot on Riser 2 (3) |
| 3. Full-height PCIe expansion card slot on Riser 3(2) | 4. Power supply unit 2 |
| 5. Power supply unit 1 | 6. System identification button |
| 7. System identification port | 8. iDRAC8 Enterprise port |
| 9. Video port | 10. Serial port |
| 11. Ethernet port | 12. USB 3.0 port |
| 13. USB 2.0 port | |

Table 3. Back panel features







Item	Indicator, button, or connector	Icon	Description
1	Full-height PCIe expansion card slot on Riser 1 (2)		Use the card slots to connect up to two full-height PCIe expansion cards on Riser 1.
2	Half-height PCIe expansion card slot on Riser 2 (3)		Use the card slots to connect up to three half-height PCIe expansion cards on Riser 2.
3	Full-height PCIe expansion card slot on Riser 3 (2)		Use the card slots to connect up to two full-height PCIe expansion cards on Riser 3.
4	Power supply unit (PSU2)		For information about supported PSUs, see the Technical specifications section.
5	Power supply unit (PSU1)		
6	System identification button		Press the system ID button:

Table 3. Back panel features (continued)

Item	Indicator, button, or connector	Icon	Description
			<ul style="list-style-type: none"> To locate a particular system within a rack. To turn the system ID on or off. <p>To reset iDRAC, press and hold the button for more than 15 seconds.</p> <p>NOTE:</p> <ul style="list-style-type: none"> To reset iDRAC using system ID, ensure that the system ID button is enabled in the iDRAC setup. If the system stops responding during POST, press and hold the system ID button (for more than five seconds) to enter the BIOS progress mode.
7	System identification port		Use the system identification port to connect the system status indicator assembly through the optional cable management arm.
8	iDRAC8 Enterprise port		Use the iDRAC8 Enterprise port to remotely access iDRAC. For more information, see the Integrated Dell Remote Access Controller User's Guide at Dell.com/idracmanuals .
9	Video port		Use the video/VGA port to connect a display to the system. For more information about the supported video/VGA port, see the Technical specifications section.
10	Serial port		Use the serial port to connect a serial device to the system. For more information about the supported serial port, see the Technical specifications section.
11	Ethernet port (4)		Use the Ethernet port to connect Local Area Networks (LANs) to the system. For more information about the supported Ethernet ports, see the Technical specifications section.
12	USB 3.0 port		Use the USB 3.0 port to connect USB devices to the system. These ports are 4-pin, USB 3.0 compliant.
13	USB 2.0 port		Use the USB 2.0 port to connect USB devices to the system. This port is 4-pin, USB 2.0 compliant.

Related references

[Technical specifications](#) on page 24

Diagnostic indicators on the front panel

NOTE: No diagnostic indicators are lit when the system is turned off. To start the system, plug it into a working power source and press the power button.

Table 4. Diagnostic indicators





Icon	Description	Condition	Corrective action
	Health indicator	<p>The indicator turns solid blue if the system is in good health.</p> <p>The indicator flashes amber:</p> <ul style="list-style-type: none"> When the system is turned on. When the system is in standby. 	<p>None required.</p> <p>Check the System Event Log or system messages for the specific issue. For more information about error messages, see the <i>Dell Event and Error Messages Reference Guide</i> at Dell.com/openmanagemanuals > OpenManage software.</p>

Table 4. Diagnostic indicators (continued)

Icon	Description	Condition	Corrective action
	Hard drive indicator	<ul style="list-style-type: none"> If any error condition exists. For example, a failed fan, PSU, or a hard drive. <p>The indicator flashes amber if there is a hard drive error.</p>	<p>The POST process is interrupted without any video output due to invalid memory configurations. See the Getting help section.</p> <p>Check the System Event Log to determine the hard drive that has an error. Run the appropriate Online Diagnostics test. Restart the system and run embedded diagnostics (ePSA). If the hard drives are configured in a RAID array, restart the system and enter the host adapter configuration utility program.</p>
	Electrical indicator	<p>The indicator flashes amber if the system experiences an electrical error (for example, voltage out of range, or a failed power supply unit (PSU) or voltage regulator).</p>	<p>Check the System Event Log or system messages for the specific issue. If it is due to a problem with the PSU, check the LED on the PSU. Reseat the PSU. If the problem persists, see the Getting help section.</p>
	Temperature indicator	<p>The indicator flashes amber if the system experiences a thermal error (for example, the ambient temperature is out of range or fan failure).</p>	<p>Ensure that none of the following conditions exist:</p> <ul style="list-style-type: none"> A cooling fan has been removed or has failed. System cover, cooling shroud, EMI filler panel, memory module blank, or back filler bracket is removed. Ambient temperature is too high. External airflow is obstructed. <p>See the Getting help section.</p>
	Memory indicator	<p>The indicator flashes amber if a memory error occurs.</p>	<p>Check the system event log or system messages for the location of the failed memory. Reseat the memory module. If the problem persists, see the Getting help section.</p>

Related references

[Getting help](#) on page 188

Hard drive indicator codes

Each hard drive carrier has an activity indicator and a status indicator. The indicators provide information about the current status of the hard drive. The activity LED indicates whether hard drive is currently in use or not. The status LED indicates the power condition of the hard drive.

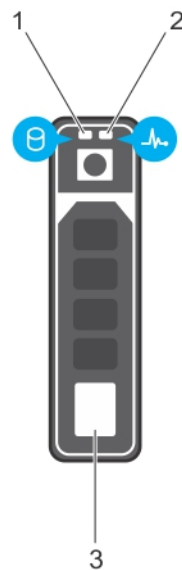

Figure 6. Hard drive indicators

1. Hard drive activity indicator
2. Hard drive status indicator
3. Hard drive

NOTE: If the hard drive is in the Advanced Host Controller Interface (AHCI) mode, the status indicator (on the right side) does not turn on.

Table 5. Hard drive indicator codes

Drive-status indicator pattern	Condition
Flashes green twice per second	Identifying drive or preparing for removal.
Off	Drive ready for insertion or removal. NOTE: The drive status indicator remains off until all hard drives are initialized after the system is turned on. Drives are not ready for insertion or removal during this time.
Flashes green, amber, and then turns off	Predicted drive failure
Flashes amber four times per second	Drive failed
Flashes green slowly	Drive rebuilding
Steady green	Drive online
Flashes green for three seconds, amber for three seconds, and then turns off after six seconds	Rebuild stopped

NIC indicator codes

The NIC on the back panel has an indicator that provides information about the network activity and link status. The activity LED indicates whether the NIC is currently connected or not. The link LED indicates the speed of the connected network.

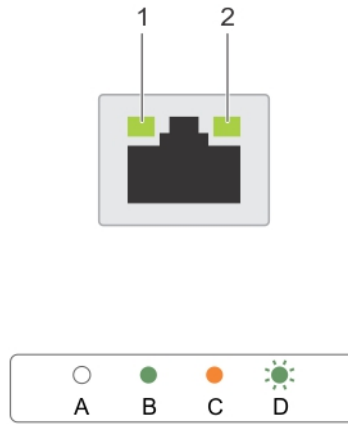

Figure 7. NIC Indicator Codes

1. link indicator
2. activity indicator

Table 6. NIC indicators

Convention	Status	Condition
A	Link and activity indicators are off.	The NIC is not connected to the network.
B	Link indicator is green.	The NIC is connected to a valid network at its maximum port speed (1 Gbps or 10 Gbps).
C	Link indicator is amber	The NIC is connected to a valid network at less than its maximum port speed.
D	Activity indicator is flashing green	Network data is being sent or received.

Power supply unit indicator codes

AC power supply units (PSUs) have an illuminated translucent handle that serves as an indicator. The indicator shows whether power is present or a power fault has occurred.



Figure 8. AC PSU status indicator

1. AC PSU status indicator/handle

Table 7. AC PSU status indicators

Convention	Power indicator pattern	Condition
A	Green	A valid power source is connected to the PSU and the PSU is operational.
B	Flashing green	When the firmware of the PSU is being updated, the PSU handle flashes green.
C	Flashing green and turns off	<p>When hot-adding a PSU, the PSU handle flashes green five times at 4 Hz rate and turns off. This indicates a PSU mismatch with respect to efficiency, feature set, health status, and supported voltage.</p> <p>NOTE: Ensure that both the PSUs are of the same capacity.</p> <p>CAUTION: For AC PSUs, use only PSUs with the Extended Power Performance (EPP) label on the back.</p> <p>NOTE: Mixing PSUs from previous generations of Dell PowerEdge servers can result in a PSU mismatch condition or failure to turn the system on.</p>
D	Flashing amber	<p>Indicates a problem with the PSU.</p> <p>CAUTION: When correcting a PSU mismatch, replace only the PSU with the flashing indicator. Swapping the PSU to make a matched pair can result in an error condition and unexpected system shutdown. To change from a high output configuration to a low output configuration or vice versa, you must turn off the system.</p> <p>CAUTION: AC PSUs support both 220 V and 110 V input voltages with the exception of Titanium PSUs, which support only 220 V. When two identical PSUs receive different input voltages, they can output different wattages, and trigger a mismatch.</p> <p>CAUTION: If two PSUs are used, they must be of the same type and have the same maximum output power.</p>
E	Not lit	Power is not connected.

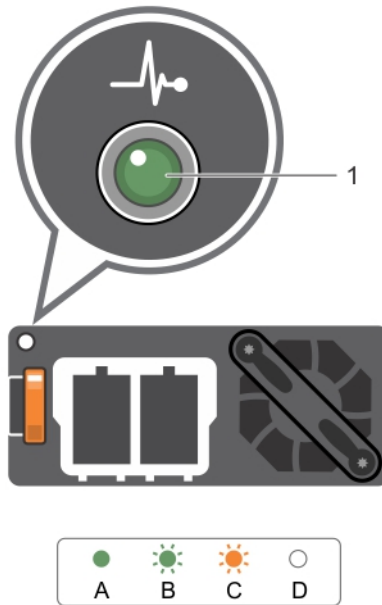

Figure 9. DC PSU status indicator

1. DC PSU status indicator

Locating service tag of your system

Your system is identified by a unique Express Service Code and Service Tag number. The Express Service Code and Service Tag are found on the front of the system by pulling out the information tag. Alternatively, the information may be on a sticker on the chassis of the system. This information is used by Dell to route support calls to the appropriate personnel.

Documentation resources

This section provides information about the documentation resources for your system.

To view the document that is listed in the documentation resources table:

- From the Dell EMC support site:
 1. Click the documentation link that is provided in the Location column in the table.
 2. Click the required product or product version.
 -  **NOTE:** To locate the product name and model, see the front of your system.
 3. On the Product Support page, click **Manuals & documents**.
- Using search engines:
 - Type the name and version of the document in the search box.

Table 8. Additional documentation resources for your system

Task	Document	Location
Setting up your system	<p>For more information about installing and securing the system into a rack, see the Rail Installation Guide included with your rack solution.</p> <p>For information about setting up your system, see the <i>Getting Started Guide</i> document that is shipped with your system.</p>	www.dell.com/poweredgemanuals
Configuring your system	<p>For information about the iDRAC features, configuring and logging in to iDRAC, and managing your system remotely, see the Integrated Dell Remote Access Controller User's Guide.</p> <p>For information about understanding Remote Access Controller Admin (RACADM) subcommands and supported RACADM interfaces, see the RACADM CLI Guide for iDRAC.</p> <p>For information about Redfish and its protocol, supported schema, and Redfish Eventing are implemented in iDRAC, see the Redfish API Guide.</p> <p>For information about iDRAC property database group and object descriptions, see the Attribute Registry Guide.</p>	www.dell.com/poweredgemanuals
	For information about earlier versions of the iDRAC documents, see the iDRAC documentation.	www.dell.com/idracmanuals

Table 8. Additional documentation resources for your system (continued)

Task	Document	Location	
	To identify the version of iDRAC available on your system, on the iDRAC web interface, click ? > About .		
	For information about installing the operating system, see the operating system documentation.	www.dell.com/operatingsystemmanuals	
	For information about updating drivers and firmware, see the Methods to download firmware and drivers section in this document.	www.dell.com/support/drivers	
Managing your system	For information about systems management software offered by Dell, see the Dell OpenManage Systems Management Overview Guide.	www.dell.com/poweredgemanuals	
	For information about setting up, using, and troubleshooting OpenManage, see the Dell OpenManage Server Administrator User's Guide.	www.dell.com/openmanagemanuals > OpenManage Server Administrator	
	For information about installing, using, and troubleshooting Dell OpenManage Essentials, see the Dell OpenManage Essentials User's Guide.	www.dell.com/openmanagemanuals > OpenManage Essentials	
	For information about installing, using, and troubleshooting Dell OpenManage Enterprise, see the Dell OpenManage Enterprise User's Guide.	www.dell.com/openmanagemanuals > OpenManage Enterprise	
		For information about partner programs enterprise systems management, see the OpenManage Connections Enterprise Systems Management documents.	www.dell.com/openmanagemanuals
Working with the Dell PowerEdge RAID controllers		For information about understanding the features of the Dell PowerEdge RAID controllers (PERC), Software RAID controllers, or BOSS card and deploying the cards, see the Storage controller documentation.	www.dell.com/storagecontrollermanuals
Understanding event and error messages	For information about the event and error messages that are generated by the system firmware and agents that monitor system components, see the Error Code Lookup.	www.dell.com/qrl	
Troubleshooting your system	For information about identifying and troubleshooting the	www.dell.com/poweredgemanuals	

Table 8. Additional documentation resources for your system (continued)

Task	Document	Location
	PowerEdge server issues, see the Server Troubleshooting Guide.	

Technical specifications

The technical and environmental specifications of your system are outlined in this section.

Topics:

- System dimensions
- Chassis weight
- Processor specifications
- PSU specifications
- System battery specifications
- Expansion bus specifications
- Memory specifications
- Drive specifications
- Ports and connectors specifications
- Video specifications
- Environmental specifications

System dimensions

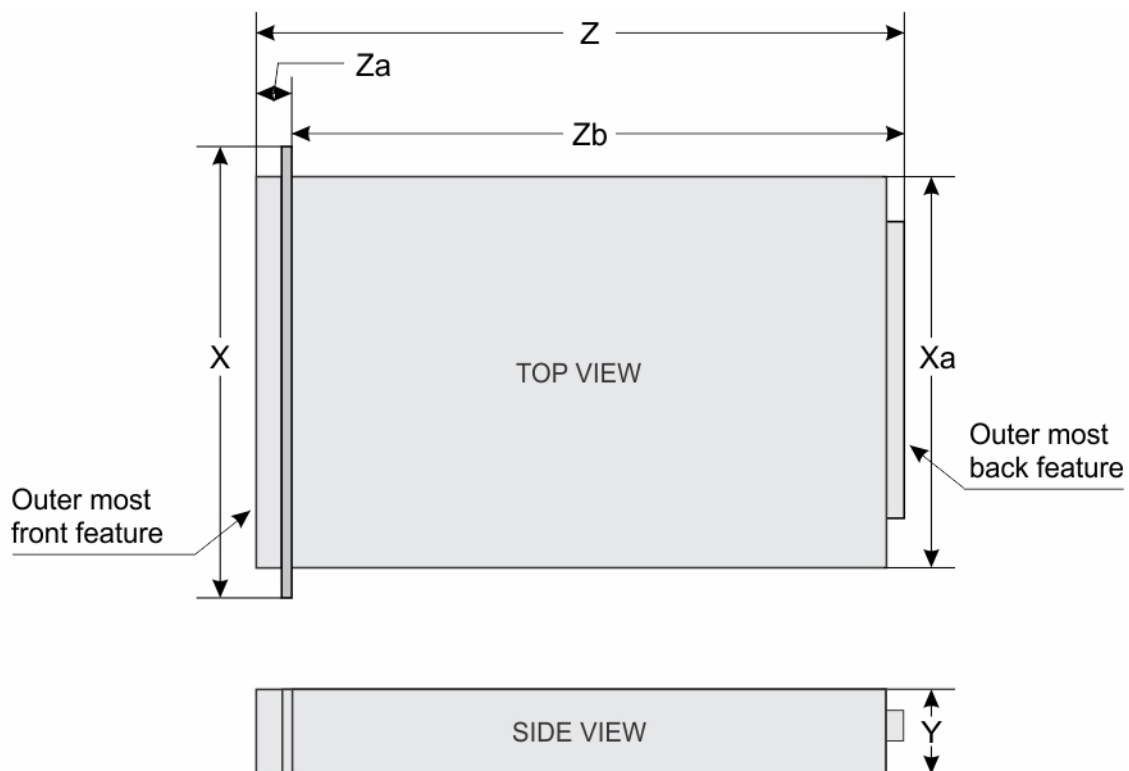

Figure 10. Dimensions of the PowerEdge R830 system

Table 9. Dimensions of the PowerEdge R830 system

X	Xa	Y	Z (with bezel)	Zb (without bezel)	Za (with bezel)	Za (without bezel)
482.4 mm (18.99 inches)	434.0 mm (17.08 inches)	86.8 mm (3.42 inches)	777.6 mm (30.61 inches)	740.6 mm (29.16 inches)	35.7 mm (1.41 inches)	20.4 mm (0.80 inches)

Chassis weight

Table 10. Chassis weight

System	Maximum weight (with all hard drives/SSDs)	Minimum weight (without any hard drives)
PowerEdge R830	31.7 kg (69.89 lb)	10.5 kg (23.15 lb)

Processor specifications

The PowerEdge R830 system supports up to four Intel Xeon E5-4600 v4 product family processors.

PSU specifications

The PowerEdge R830 system supports up to two AC redundant power supply units (PSU).

Table 11. PSU specifications

PSU	Class	Heat dissipation (maximum)	Frequency	Voltage
750 W AC	Platinum		50/60 Hz	100–240 V AC, autoranging
1600 W AC	Platinum			100–240 V AC, autoranging <i>i</i> NOTE: If a system with 1600 W PSUs operates from 100 to 120 V, then the power rating per PSU is derated to 800 W.

i **NOTE:** Heat dissipation is calculated using the PSU wattage rating.

i **NOTE:** This system is also designed to connect to the IT power systems with a phase to phase voltage not exceeding 230 V.

i **NOTE:** PSUs rated for 1600 W and higher require high-line voltage (200-240 V) to supply their rated capacity.

System battery specifications

The PowerEdge R830 system supports CR 2032 3.0-V lithium coin cell system battery.

Expansion bus specifications

The PowerEdge R830 system supports PCI express (PCIe) generation 3 expansion cards, which need to be installed on the system board using expansion card risers. This system supports three types of expansion card risers.

Memory specifications

The PowerEdge R830 system supports DDR4 registered DIMMs (RDIMMs) and load-reduced DIMMs (LRDIMMs).

Table 12. Memory specifications

Memory module sockets	Memory capacity	Minimum RAM	Maximum RAM
Forty-eight DIMM sockets	<ul style="list-style-type: none">64 GB quad rank (LRDIMMs)8 GB single rank (RDIMMs)16 GB or 32 GB dual rank (RDIMMs)	8 GB with dual processors (minimum one memory module per processor)	LRDIMM up to 6144 GB with four processors

Drive specifications

Hard drives

The PowerEdge R830 system supports SAS, SATA, or Nearline SAS hard drives.

Table 13. Supported hard drive options for the PowerEdge R830 system

Sixteen hard drive systems	Up to sixteen 2.5-inch, internal, hot-swappable SAS, SATA, SAS/SATA SSD, or Nearline SAS hard drives
----------------------------	--

Optical drive

The system supports one optional SATA DVD-ROM drive or DVD+/-RW drive.

Ports and connectors specifications

USB ports

The PowerEdge R830 system supports:

- USB 2.0-compliant ports on the front and back panel
- USB 3.0-complaint port on the back panel

The following table provides more information about the USB specifications:

Table 14. USB specifications

System	Front panel	Back panel
PowerEdge R830	<ul style="list-style-type: none">• One 4-pin, USB 2.0-compliant port• One USB management port/iDRAC Direct	<ul style="list-style-type: none">• One 4-pin, USB 2.0-compliant port• One 4-pin, USB 3.0-compliant port

NIC ports

The PowerEdge R830 system supports four Network Interface Controller (NIC) ports on the back panel, which are available in the following two configurations:

- four 1 Gbps, or

- two 10 Gbps

NOTE: You can install up to six PCIe add-on NIC cards.

Serial connector

The serial connector connects a serial device to the system. The PowerEdge R830 system supports one serial connector on the back panel, which is a 9-pin connector, Data Terminal Equipment (DTE), 16550-compliant.

VGA ports

The Video Graphic Array (VGA) port enables you to connect the system to a VGA display. The PowerEdge R830 system supports two 15-pin VGA ports on the front and back panels.

Internal Dual SD Module

The PowerEdge R830 system supports two optional flash memory card slots with an internal dual SD module.

NOTE: One card slot is dedicated for redundancy.

Video specifications

The PowerEdge R830 system supports Matrox G200eR2 graphics card with 16 MB capacity.

Table 15. Supported video resolution options

Resolution	Refresh rate (Hz)	Color depth (bits)
640x480	60,70	8, 16, 32
800x600	60,75, 85	8, 16, 32
1024x768	60,75, 85	8, 16, 32
1152x864	60,75, 85	8, 16, 32
1280x1024	60,75	8, 16, 32
1440x900	60	8, 16, 32

Environmental specifications

NOTE: For additional information about environmental measurements for specific system configurations, see [Dell.com/environmental_datasheets](https://www.dell.com/environmental_datasheets).

Table 16. Temperature specifications

Temperature	Specifications
Storage	-40°C to 65°C (-40°F to 149°F)
Continuous operation (for altitude less than 950 m or 3117 ft)	5°C to 40°C (41°F to 104°F) with no direct sunlight on the equipment.
Fresh air	For information about fresh air, see Expanded Operating Temperature section.
Maximum temperature gradient (operating and storage)	20°C/h (68°F/h)

Table 17. Relative humidity specifications

Relative humidity	Specifications
Storage	5% to 95% RH with 33°C (91°F) maximum dew point. Atmosphere must be non-condensing at all times.
Operating	5% to 85% relative humidity with 29°C (84.2°F) maximum dew point.

Table 18. Maximum vibration specifications

Maximum vibration	Specifications
Operating	0.26 G _{rms} at 5 Hz to 350 Hz (all operation orientations).
Storage	1.88 G _{rms} at 10 Hz to 500 Hz for 15 min (all six sides tested).

Table 19. Maximum shock specifications

Maximum shock	Specifications
Operating	Six consecutively executed shock pulses in the positive and negative x, y, and z axes of 6 G for up to 11 ms.
Storage	Six consecutively executed shock pulses in the positive and negative x, y, and z axes (one pulse on each side of the system) of 71 G for up to 2 ms.

Table 20. Maximum altitude specifications

Maximum altitude	Specifications
Operating	30482000 m (10,0006560 ft)
Storage	12,000 m (39,370 ft)

Table 21. Operating temperature de-rating specifications

Operating temperature de-rating	Specifications
Up to 35°C (95°F)	Maximum temperature is reduced by 1°C/300 m (1°F/547 ft) above 950 m (3,117 ft).
35°C to 40°C (95°F to 104°F)	Maximum temperature is reduced by 1°C/175 m (1°F/319 ft) above 950 m (3,117 ft).
40°C to 45°C (104°F to 113°F)	Maximum temperature is reduced by 1°C/125 m (1°F/228 ft) above 950 m (3,117 ft).

Related references

[Expanded operating temperature](#) on page 29

Particulate and gaseous contamination specifications

The following table defines the limitations that help avoid any equipment damage or failure from particulates and gaseous contamination. If the levels of particulates or gaseous pollution exceed the specified limitations and result in equipment damage or failure, you may need to rectify the environmental conditions. Re-mediation of environmental conditions is the responsibility of the customer.

Table 22. Particulate contamination specifications

Particulate contamination	Specifications
Air filtration	Data center air filtration as defined by ISO Class 8 per ISO 14644-1 with a 95% upper confidence limit.  NOTE: This condition applies to data center environments only. Air filtration requirements do not apply to IT equipment designed to be

Table 22. Particulate contamination specifications (continued)

Particulate contamination	Specifications
	<p>used outside a data center, in environments such as an office or factory floor.</p> <p>i NOTE: Air entering the data center must have MERV11 or MERV13 filtration.</p>
Conductive dust	<p>Air must be free of conductive dust, zinc whiskers, or other conductive particles.</p> <p>i NOTE: This condition applies to data center and non-data center environments.</p>
Corrosive dust	<ul style="list-style-type: none"> • Air must be free of corrosive dust. • Residual dust present in the air must have a deliquescent point less than 60% relative humidity. <p>i NOTE: This condition applies to data center and non-data center environments.</p>

Table 23. Gaseous contamination specifications

Gaseous contamination	Specifications
Copper coupon corrosion rate	<300 Å/month per Class G1 as defined by ANSI/ISA71.04-1985.
Silver coupon corrosion rate	<200 Å/month as defined by AHSRAE TC9.9.

i **NOTE:** Maximum corrosive contaminant levels measured at ≤50% relative humidity.

Standard operating temperature

Table 24. Standard operating temperature specifications

Standard operating temperature	Specifications
Continuous operation (for altitude less than 950 m or 3117 ft)	<p>5°C to 40°C (41°F to 104°F) with no direct sunlight on the equipment.</p> <p>i NOTE: The chassis supports a maximum of 135 W processors.</p>

Expanded operating temperature

Table 25. Expanded operating temperature specifications

Expanded operating temperature	Specifications
Continuous operation	<p>5°C to 40°C at 5% to 85% RH with 29°C dew point.</p> <p>i NOTE: Outside the standard operating temperature (10°C to 35°C), the system can operate continuously in temperatures as low as 5°C and as high as 40°C.</p> <p>For temperatures between 35°C and 40°C, de-rate maximum allowable temperature by 1°C per 175 m above 950 m (1°F per 319 ft).</p>
≤ 1% of annual operating hours	<p>–5°C to 45°C at 5% to 90% RH with 29°C dew point.</p> <p>i NOTE: Outside the standard operating temperature (10°C to 35°C), the system can operate down to –5°C or up to 45°C for a maximum of 1% of its annual operating hours.</p>

Table 25. Expanded operating temperature specifications (continued)

Expanded operating temperature	Specifications
	For temperatures between 40°C and 45°C, de-rate maximum allowable temperature by 1°C per 125 m above 950 m (1°F per 228 ft).

NOTE: When operating in the expanded temperature range, system performance may be impacted.

NOTE: When operating in the expanded temperature range, ambient temperature warnings may be reported on the LCD panel and in the System Event Log.

Expanded operating temperature restrictions

- Do not perform a cold startup below 5°C.
- The operating temperature specified is for a maximum altitude of 950 m.
- PCIe Cards are not supported on slot 1 and 2.
- A maximum of eight hard drives are supported on systems with a 135 W processor.
- Redundant power supplies are required.
- Non-Dell qualified peripheral cards and/or peripheral cards greater than 25 W are not supported.

Initial system setup and configuration

Topics:

- [Setting up your system](#)
- [iDRAC configuration](#)
- [Options to install the operating system](#)

Setting up your system

Complete the following steps to set up your system:

Steps

1. Unpack the system.
2. Install the system into the rack. For more information about installing the system into the rack, see your system *Rack Installation Placemat* at Dell.com/poweredgemanuals.
3. Connect the peripherals to the system.
4. Connect the system to its electrical outlet.
5. Turn the system on by pressing the power button or by using iDRAC.
6. Turn on the attached peripherals.

iDRAC configuration

The Integrated Dell Remote Access Controller (iDRAC) is designed to make system administrators more productive and improve the overall availability of Dell EMC systems. iDRAC alerts administrators to system issues, helps them perform remote system management, and reduces the need for physical access to the system.

Options to set up iDRAC IP address

You must configure the initial network settings based on your network infrastructure to enable the communication to and from iDRAC. You can set up the IP address by using one of the following interfaces:

Interfaces	Document/Section
iDRAC Settings utility	See <i>Dell Integrated Dell Remote Access Controller User's Guide</i> at Dell.com/idracmanuals
Dell Deployment Toolkit	See <i>Dell Deployment Toolkit User's Guide</i> at Dell.com/openmanagemanuals
Dell Lifecycle Controller	See <i>Dell Lifecycle Controller User's Guide</i> at Dell.com/idracmanuals
Chassis or Server LCD panel	See the LCD panel section

You must use the default iDRAC IP address 192.168.0.120 to configure the initial network settings, including setting up DHCP or a static IP for iDRAC.

 **NOTE:** To access iDRAC connect the network cable to the Ethernet connector on the system board.

 **NOTE:** Ensure that you change the default user name and password after setting up the iDRAC IP address.

Related references

[LCD panel](#) on page 12

Log in to iDRAC

You can log in to iDRAC as:

- iDRAC user
- Microsoft Active Directory user
- Lightweight Directory Access Protocol (LDAP) user

The default user name and password are `root` and `calvin`. You can also log in by using Single Sign-On or Smart Card.

 **NOTE:** You must have iDRAC credentials to log in to iDRAC.

For more information about logging in to iDRAC and iDRAC licenses, see the latest Integrated Dell Remote Access Controller User's Guide at [Dell.com/idracmanuals](https://www.dell.com/idracmanuals).

Options to install the operating system

If the system is shipped without an operating system, install the supported operating system by using one of the following resources:

Table 26. Resources to install the operating system

Resources	Location
Dell Systems Management Tools and Documentation media	https://www.dell.com/operatingsystemmanuals
Dell Lifecycle Controller	https://www.dell.com/idracmanuals
Dell OpenManage Deployment Toolkit	https://www.dell.com/openmanagemanuals
Dell certified VMware ESXi	https://www.dell.com/virtualizationsolutions
Supported operating systems on Dell PowerEdge systems	www.dell.com/ossupport
Installation and How-to videos for supported operating systems on Dell PowerEdge systems	https://www.youtube.com/playlist?list=PLe5xhhyFjDPfTCaDRFfIB_VsoLpL8x84G

Methods to download firmware and drivers

You can download the firmware and drivers by using any of the following methods:

Table 27. Firmware and drivers

Methods	Location
From the Dell Support site	Global Technical Support
Using Dell Remote Access Controller Lifecycle Controller (iDRAC with LC)	Dell.com/idracmanuals
Using Dell Repository Manager (DRM)	Dell.com/openmanagemanuals > OpenManage Deployment Toolkit
Using Dell OpenManage Essentials (OME)	Dell.com/openmanagemanuals > OpenManage Deployment Toolkit
Using Dell Server Update Utility (SUU)	Dell.com/openmanagemanuals > OpenManage Deployment Toolkit
Using Dell OpenManage Deployment Toolkit (DTK)	Dell.com/openmanagemanuals > OpenManage Deployment Toolkit

Downloading the drivers and firmware

Dell EMC recommends that you download and install the latest BIOS, drivers, and systems management firmware on your system.

Prerequisites

Ensure that you clear the web browser cache before downloading the drivers and firmware.

Steps

1. Go to Dell.com/support/drivers.
2. In the **Drivers & Downloads** section, type the Service Tag of your system in the **Service Tag or Express Service Code** box, and then click **Submit**.
 **NOTE:** If you do not have the Service Tag, select **Detect My Product** to allow the system to automatically detect your Service Tag, or in **General support**, navigate to your product.
3. Click **Drivers & Downloads**.
The drivers that are applicable to your selection are displayed.
4. Download the drivers to a USB drive, CD, or DVD.

Pre-operating system management applications

You can manage basic settings and features of a system without booting to the operating system by using the system firmware.

Topics:

- [Options to manage the pre-operating system applications](#)
- [System Setup](#)
- [Dell Lifecycle Controller](#)
- [Boot Manager](#)
- [PXE boot](#)

Options to manage the pre-operating system applications

Your system has the following options to manage the pre-operating system applications:

- System Setup
- Boot Manager
- Dell Lifecycle Controller
- Preboot Execution Environment (PXE)

Related concepts

[System Setup](#) on page 34

[Boot Manager](#) on page 60

[Dell Lifecycle Controller](#) on page 60

[PXE boot](#) on page 62

System Setup

By using the **System Setup** screen, you can configure the BIOS settings, iDRAC settings, and device settings of your system.

 **NOTE:** Help text for the selected field is displayed in the graphical browser by default. To view the help text in the text browser, press F1.

You can access system setup by using two methods:

- Standard graphical browser — The browser is enabled by default.
- Text browser — The browser is enabled by using Console Redirection.

Related references

[System Setup details](#) on page 35

Related tasks

[Viewing System Setup](#) on page 35

Viewing System Setup

To view the **System Setup** screen, perform the following steps:

Steps

1. Turn on, or restart your system.
2. Press F2 immediately after you see the following message:

```
F2 = System Setup
```

NOTE: If your operating system begins to load before you press F2, wait for the system to finish booting, and then restart your system and try again.

Related concepts

[System Setup](#) on page 34

Related references

[System Setup details](#) on page 35

System Setup details

The **System Setup Main Menu** screen details are explained as follows:

Option	Description
System BIOS	Enables you to configure BIOS settings.
iDRAC Settings	Enables you to configure iDRAC settings. The iDRAC settings utility is an interface to set up and configure the iDRAC parameters by using UEFI (Unified Extensible Firmware Interface). You can enable or disable various iDRAC parameters by using the iDRAC settings utility. For more information about this utility, see <i>Integrated Dell Remote Access Controller User's Guide</i> at Dell.com/idracmanuals .
Device Settings	Enables you to configure device settings.

Related concepts

[System Setup](#) on page 34

[System BIOS](#) on page 35

Related references

[iDRAC Settings utility](#) on page 59

[Device Settings](#) on page 60

Related tasks

[Viewing System Setup](#) on page 35

System BIOS

You can use the **System BIOS** screen to edit specific functions such as boot order, system password, setup password, set the RAID mode, and enable or disable USB ports.

Related references

[System BIOS Settings details](#) on page 36

- [Boot Settings](#) on page 37
- [Network Settings](#) on page 39
- [System Security](#) on page 41
- [System Information](#) on page 45
- [Memory Settings](#) on page 46
- [Processor Settings](#) on page 48
- [SATA Settings](#) on page 50
- [Integrated Devices](#) on page 53
- [Serial Communication](#) on page 54
- [System Profile Settings](#) on page 56
- [Miscellaneous Settings](#) on page 58
- [iDRAC Settings utility](#) on page 59
- [Device Settings](#) on page 60

Related tasks

- [Viewing System BIOS](#) on page 36

Viewing System BIOS

To view the **System BIOS** screen, perform the following steps:

Steps

1. Turn on, or restart your system.
2. Press F2 immediately after you see the following message:

```
F2 = System Setup
```

NOTE: If your operating system begins to load before you press F2, wait for the system to finish booting, and then restart your system and try again.

3. On the **System Setup Main Menu** screen, click **System BIOS**.

Related references

- [System BIOS](#) on page 35
- [System BIOS Settings details](#) on page 36

System BIOS Settings details

About this task

The **System BIOS Settings** screen details are explained as follows:

Option	Description
System Information	Specifies information about the system such as the system model name, BIOS version, and Service Tag.
Memory Settings	Specifies information and options related to the installed memory.
Processor Settings	Specifies information and options related to the processor such as speed and cache size.
SATA Settings	Specifies options to enable or disable the integrated SATA controller and ports.
Boot Settings	Specifies options to specify the boot mode (BIOS or UEFI). Enables you to modify UEFI and BIOS boot settings.
Network Settings	Specifies options to change the network settings.

Option	Description
Integrated Devices	Specifies options to manage integrated device controllers and ports and specify related features and options.
Serial Communication	Specifies options to manage the serial ports and specify related features and options.
System Profile Settings	Specifies options to change the processor power management settings, memory frequency, and so on.
System Security	Specifies options to configure the system security settings, such as system password, setup password, Trusted Platform Module (TPM) security. It also manages the power and NMI buttons on the system.
Miscellaneous Settings	Specifies options to change the system date, time, and so on.

Related references

[System BIOS](#) on page 35

Related tasks

[Viewing System BIOS](#) on page 36

Boot Settings

You can use the **Boot Settings** screen to set the boot mode to either **BIOS** or **UEFI**. It also enables you to specify the boot order.

Related references

[System BIOS](#) on page 35

[Choosing the system boot mode](#) on page 38

Related tasks

[Boot Settings details](#) on page 38

[Viewing Boot Settings](#) on page 37

[Changing the boot order](#) on page 39

Viewing Boot Settings

To view the **Boot Settings** screen, perform the following steps:

Steps

1. Turn on, or restart your system.
2. Press F2 immediately after you see the following message:

```
F2 = System Setup
```

NOTE: If your operating system begins to load before you press F2, wait for the system to finish booting, and then restart your system and try again.

3. On the **System Setup Main Menu** screen, click **System BIOS**.
4. On the **System BIOS** screen, click **Boot Settings**.

Related references

[Boot Settings](#) on page 37

[Choosing the system boot mode](#) on page 38

Related tasks





[Boot Settings details](#) on page 38

[Changing the boot order](#) on page 39

Boot Settings details

About this task

The **Boot Settings** screen details are explained as follows:

Option	Description
Boot Mode	<p>Enables you to set the boot mode of the system.</p> <p> CAUTION: Switching the boot mode may prevent the system from booting if the operating system is not installed in the same boot mode.</p> <p>If the operating system supports UEFI, you can set this option to UEFI. Setting this field to BIOS allows compatibility with non-UEFI operating systems. This option is set to BIOS by default.</p> <p> NOTE: Setting this field to UEFI disables the BIOS Boot Settings menu. Setting this field to BIOS disables the UEFI Boot Settings menu.</p>
Boot Sequence Retry	<p>Enables or disables the Boot Sequence Retry feature. If this option is set to Enabled and the system fails to boot, the system reattempts the boot sequence after 30 seconds. This option is set to Enabled by default.</p>
Hard-Disk Failover	<p>Specifies the hard drive that is booted in the event of a hard drive failure. The devices are selected in the Hard-Disk Drive Sequence on the Boot Option Setting menu. When this option is set to Disabled, only the first hard drive in the list is attempted to boot. When this option is set to Enabled, all hard drives are attempted to boot in the order selected in the Hard-Disk Drive Sequence. This option is not enabled for UEFI Boot Mode.</p>
Boot Option Settings	<p>Configures the boot sequence and the boot devices.</p>
BIOS Boot Settings	<p>Enables or disables BIOS boot options.</p> <p> NOTE: This option is enabled only if the boot mode is BIOS.</p>
UEFI Boot Settings	<p>Enables or disables UEFI Boot options. The Boot options include IPv4 PXE and IPv6 PXE. This option is set to IPv4 by default.</p> <p> NOTE: This option is enabled only if the boot mode is UEFI.</p>

Related references

[Boot Settings](#) on page 37

[Choosing the system boot mode](#) on page 38

Related tasks

[Viewing Boot Settings](#) on page 37

[Changing the boot order](#) on page 39

Choosing the system boot mode

System Setup enables you to specify one of the following boot modes for installing your operating system:

- BIOS boot mode (the default) is the standard BIOS-level boot interface.
- Unified Extensible Firmware Interface (UEFI) (the default) boot mode is an enhanced 64-bit boot interface. If you have configured your system to boot to UEFI mode, it replaces the system BIOS.

1. From the **System Setup Main Menu**, click **Boot Settings**, and select **Boot Mode**.
2. Select the boot mode you want the system to boot into.

 **CAUTION:** Switching the boot mode may prevent the system from booting if the operating system is not installed in the same boot mode.

3. After the system boots in the specified boot mode, proceed to install your operating system from that mode.

 **NOTE:**

- Operating systems must be UEFI-compatible to be installed from the UEFI boot mode. DOS and 32-bit operating systems do not support UEFI and can only be installed from the BIOS boot mode.
- For the latest information about supported operating systems, go to Dell.com/ossupport.

Related references

[Boot Settings](#) on page 37

Related tasks

[Boot Settings details](#) on page 38

[Viewing Boot Settings](#) on page 37

Changing the boot order

About this task

You may have to change the boot order if you want to boot from a USB key or an optical drive. The following instructions may vary if you have selected **BIOS** for **Boot Mode**.

Steps

1. On the **System Setup Main Menu** screen, click **System BIOS > Boot Settings**.
2. Click **Boot Option Settings > Boot Sequence**.
3. Use the arrow keys to select a boot device, and use the plus (+) and minus (-) sign keys to move the device down or up in the order.
4. Click **Exit**, and then click **Yes** to save the settings on exit.

Related references

[Boot Settings](#) on page 37

Related tasks

[Boot Settings details](#) on page 38

[Viewing Boot Settings](#) on page 37

Network Settings

You can use the **Network Settings** screen to modify PXE device settings. The network settings option is available only in the UEFI mode.

 **NOTE:** The BIOS does not control network settings in the BIOS mode. For the BIOS boot mode, the optional Boot ROM of the network controllers handles the network settings.

Related concepts

[UEFI iSCSI Settings](#) on page 40

Related references

[Network Settings screen details](#) on page 40

[UEFI iSCSI Settings details](#) on page 41

[System BIOS](#) on page 35

Related tasks

[Viewing Network Settings](#) on page 40

[Viewing UEFI iSCSI Settings](#) on page 41

Viewing Network Settings

To view the **Network Settings** screen, perform the following steps:

Steps

1. Turn on, or restart your system.
2. Press F2 immediately after you see the following message:

```
F2 = System Setup
```

 **NOTE:** If your operating system begins to load before you press F2, wait for the system to finish booting, and then restart your system and try again.

3. On the **System Setup Main Menu** screen, click **System BIOS**.
4. On the **System BIOS** screen, click **Network Settings**.

Related references

[Network Settings](#) on page 39

[Network Settings screen details](#) on page 40

Network Settings screen details

The **Network Settings** screen details are explained as follows:

About this task

Option	Description
PXE Device n (n = 1 to 4)	Enables or disables the device. When enabled, a UEFI boot option is created for the device.
PXE Device n Settings(n = 1 to 4)	Enables you to control the configuration of the PXE device.

Related references

[Network Settings](#) on page 39

Related tasks

[Viewing Network Settings](#) on page 40

UEFI iSCSI Settings

You can use the iSCSI Settings screen to modify iSCSI device settings. The iSCSI Settings option is available only in the UEFI boot mode. BIOS does not control network settings in the BIOS boot mode. For the BIOS boot mode, the option ROM of the network controller handles the network settings.

Related references

[UEFI iSCSI Settings details](#) on page 41

Related tasks

[Viewing UEFI iSCSI Settings](#) on page 41

Viewing UEFI iSCSI Settings

To view the **UEFI iSCSI Settings** screen, perform the following steps:

Steps

1. Turn on, or restart your system.
2. Press F2 immediately after you see the following message:

```
F2 = System Setup
```

NOTE: If your operating system begins to load before you press F2, wait for the system to finish booting, and then restart your system and try again.

3. On the **System Setup Main Menu** screen, click **System BIOS**.
4. On the **System BIOS** screen, click **Network Settings**.
5. On the **Network Settings** screen, click **UEFI iSCSI Settings**.

Related concepts

[UEFI iSCSI Settings](#) on page 40

Related references

[UEFI iSCSI Settings details](#) on page 41

UEFI iSCSI Settings details

The **UEFI iSCSI Settings** screen details are explained as follows:

Option	Description
iSCSI Initiator Name	Specifies the name of the iSCSI initiator (iqn format).
iSCSI Device n (n = 1 to 4)	Enables or disables the iSCSI device. When disabled, a UEFI boot option is created for the iSCSI device automatically.

Related concepts

[UEFI iSCSI Settings](#) on page 40

Related tasks

[Viewing UEFI iSCSI Settings](#) on page 41

System Security

You can use the **System Security** screen to perform specific functions such as setting the system password, setup password and disabling the power button.

Related references

[Operating with a setup password enabled](#) on page 44

[System BIOS](#) on page 35

Related tasks

[System Security Settings details](#) on page 42

[Viewing System Security](#) on page 42

- [Creating a system and setup password on page 43](#)
- [Using your system password to secure your system on page 44](#)
- [Deleting or changing system and setup password on page 44](#)

Viewing System Security

To view the **System Security** screen, perform the following steps:

Steps

1. Turn on, or restart your system.
2. Press F2 immediately after you see the following message:

F2 = System Setup

 **NOTE:** If your operating system begins to load before you press F2, wait for the system to finish booting, and then restart your system and try again.

3. On the **System Setup Main Menu** screen, click **System BIOS**.
4. On the **System BIOS** screen, click **System Security**.

Related references

[System Security on page 41](#)



Related tasks

[System Security Settings details on page 42](#)

System Security Settings details

About this task

The **System Security Settings** screen details are explained as follows:

Option	Description
Intel AES-NI	Improves the speed of applications by performing encryption and decryption by using the Advanced Encryption Standard Instruction Set (AES-NI). This option is set to Enabled by default.
System Password	Sets the system password. This option is set to Enabled by default and is read-only if the password jumper is not installed in the system.
Setup Password	Sets the setup password. This option is read-only if the password jumper is not installed in the system.
Password Status	Locks the system password. This option is set to Unlocked by default.
TPM Security	<p> NOTE: The TPM menu is available only when the TPM module is installed.</p> <p>Enables you to control the reporting mode of the TPM. The TPM Security option is set to Off by default. You can only modify the TPM Status, TPM Activation, and Intel TXT fields if the TPM Status field is set to either On with Pre-boot Measurements or On without Pre-boot Measurements.</p>
TPM Information	Changes the operational state of the TPM. This option is set to No Change by default.
TPM Status	Specifies the TPM status.
TPM Command	<p> CAUTION: Clearing the TPM results in the loss of all keys in the TPM. The loss of TPM keys may affect booting to the operating system.</p> <p>Clears all the contents of the TPM. The TPM Clear option is set to No by default.</p>
Intel TXT	Enables or disables the Intel Trusted Execution Technology (TXT) option. To enable the Intel TXT option, virtualization technology and TPM Security must be enabled with Pre-boot measurements. This option is set to Off by default.

Option	Description
Power Button	Enables or disables the power button on the front of the system. This option is set to Enabled by default.
NMI Button	Enables or disables the NMI button on the front of the system. This option is set to Disabled by default.
AC Power Recovery	Sets how the system behaves after AC power is restored to the system. This option is set to Last by default.
AC Power Recovery Delay	Sets the time delay for the system to power up after AC power is restored to the system. This option is set to Immediate by default.
User Defined Delay (60s to 240s)	Sets the User Defined Delay option when the User Defined option for AC Power Recovery Delay is selected.
UEFI Variable Access	Provides varying degrees of securing UEFI variables. When set to Standard (the default), UEFI variables are accessible in the operating system per the UEFI specification. When set to Controlled , selected UEFI variables are protected in the environment and new UEFI boot entries are forced to be at the end of the current boot order.
Secure Boot Policy	When Secure Boot policy is set to Standard , the BIOS uses the system manufacturer's key and certificates to authenticate pre-boot images. When Secure Boot policy is set to Custom , the BIOS uses the user-defined key and certificates. Secure Boot policy is set to Standard by default.
Secure Boot Policy Summary	Specifies the list of certificates and hashes that secure boot uses to authenticate images.

Related references

[System Security](#) on page 41

Related tasks

[Viewing System Security](#) on page 42

Creating a system and setup password

Prerequisites

Ensure that the password jumper is enabled. The password jumper enables or disables the system password and setup password features. For more information, see the System board jumper settings section.

 **NOTE:** If the password jumper setting is disabled, the existing system password and setup password are deleted and you need not provide the system password to boot the system.

Steps

1. To enter System Setup, press F2 immediately after turning on or rebooting your system.
2. On the **System Setup Main Menu** screen, click **System BIOS > System Security**.
3. On the **System Security** screen, verify that **Password Status** is set to **Unlocked**.
4. In the **System Password** field, type your system password, and press Enter or Tab.

Use the following guidelines to assign the system password:

- A password can have up to 32 characters.
- The password can contain the numbers 0 through 9.
- Only the following special characters are allowed: space, ("), (+), (.), (-), (/), (:), ([), (\), (]), (`).

A message prompts you to reenter the system password.

5. Reenter the system password, and click **OK**.
6. In the **Setup Password** field, type your setup password and press Enter or Tab.
A message prompts you to reenter the setup password.
7. Reenter the setup password, and click **OK**.
8. Press Esc to return to the System BIOS screen. Press Esc again.
A message prompts you to save the changes.

 **NOTE:** Password protection does not take effect until the system reboots.

Related references

[System Security](#) on page 41

Using your system password to secure your system

About this task

If you have assigned a setup password, the system accepts your setup password as an alternate system password.

Steps

1. Turn on or reboot your system.
2. Type the system password and press Enter.

Next steps

When **Password Status** is set to **Locked**, type the system password and press Enter when prompted at reboot.

 **NOTE:** If an incorrect system password is typed, the system displays a message and prompts you to reenter your password. You have three attempts to type the correct password. After the third unsuccessful attempt, the system displays an error message that the system has stopped functioning and must be turned off. Even after you turn off and restart the system, the error message is displayed until the correct password is entered.

Related references

[System Security](#) on page 41

Deleting or changing system and setup password

Prerequisites

 **NOTE:** You cannot delete or change an existing system or setup password if the **Password Status** is set to **Locked**.

Steps

1. To enter System Setup, press F2 immediately after turning on or restarting your system.
2. On the **System Setup Main Menu** screen, click **System BIOS > System Security**.
3. On the **System Security** screen, ensure that **Password Status** is set to **Unlocked**.
4. In the **System Password** field, alter or delete the existing system password, and then press Enter or Tab.
5. In the **Setup Password** field, alter or delete the existing setup password, and then press Enter or Tab.
If you change the system and setup password, a message prompts you to reenter the new password. If you delete the system and setup password, a message prompts you to confirm the deletion.
6. Press Esc to return to the **System BIOS** screen. Press Esc again, and a message prompts you to save the changes.

Related references

[System Security](#) on page 41

Operating with a setup password enabled

If **Setup Password** is set to **Enabled**, type the correct setup password before modifying the system setup options.

If you do not type the correct password in three attempts, the system displays the following message:

```
Invalid Password! Number of unsuccessful password attempts: <x> System Halted! Must power down.
```

Even after you turn off and restart the system, the error message is displayed until the correct password is typed. The following options are exceptions:

- If **System Password** is not set to **Enabled** and is not locked through the **Password Status** option, you can assign a system password. For more information, see the System Security Settings screen section.
- You cannot disable or change an existing system password.

 **NOTE:** You can use the password status option with the setup password option to protect the system password from unauthorized changes.

Related references

[System Security](#) on page 41

System Information

You can use the **System Information** screen to view system properties such as Service Tag, system model name, and the BIOS version.

Related references

[System Information details](#) on page 45

[System BIOS](#) on page 35

Related tasks

[Viewing System Information](#) on page 45

Viewing System Information

To view the **System Information** screen, perform the following steps:

Steps

1. Turn on, or restart your system.
2. Press F2 immediately after you see the following message:

```
F2 = System Setup
```

 **NOTE:** If your operating system begins to load before you press F2, wait for the system to finish booting, and then restart your system and try again.

3. On the **System Setup Main Menu** screen, click **System BIOS**.
4. On the **System BIOS** screen, click **System Information**.

Related references

[System Information](#) on page 45

System Information details

About this task

The **System Information** screen details are explained as follows:

Option	Description
System Model Name	Specifies the system model name.
System BIOS Version	Specifies the BIOS version installed on the system.
System Management Engine Version	Specifies the current version of the Management Engine firmware.
System Service Tag	Specifies the system Service Tag.
System Manufacturer	Specifies the name of the system manufacturer.
System Manufacturer Contact Information	Specifies the contact information of the system manufacturer.
System CPLD Version	Specifies the current version of the system complex programmable logic device (CPLD) firmware.
UEFI Compliance Version	Specifies the UEFI compliance level of the system firmware.

Related references

[System Information](#) on page 45

[System Information details](#) on page 45

Related tasks

[Viewing System Information](#) on page 45

Memory Settings

You can use the **Memory Settings** screen to view all the memory settings and enable or disable specific memory functions, such as memory testing and node interleaving.

Related references

[Memory Settings details](#) on page 47

[System BIOS](#) on page 35

Related tasks

[Viewing Memory Settings](#) on page 46

Viewing Memory Settings

To view the **Memory Settings** screen, perform the following steps:

Steps

1. Turn on, or restart your system.
2. Press F2 immediately after you see the following message:

```
F2 = System Setup
```

 **NOTE:** If your operating system begins to load before you press F2, wait for the system to finish booting, and then restart your system and try again.

3. On the **System Setup Main Menu** screen, click **System BIOS**.
4. On the **System BIOS** screen, click **Memory Settings**.

Related references



[Memory Settings](#) on page 46

[Memory Settings details](#) on page 47

Memory Settings details

About this task

The **Memory Settings** screen details are explained as follows:

Option	Description
System Memory Size	Specifies the memory size in the system.
System Memory Type	Specifies the type of memory installed in the system.
System Memory Speed	Specifies the memory speed.
System Memory Voltage	Specifies the memory voltage.
Video Memory	Specifies the amount of video memory.
System Memory Testing	Specifies whether the memory tests are run during system boot. Options are Enabled and Disabled . This option is set to Disabled by default.
Memory Operating Mode	<p>Specifies the memory operating mode. The options available are Optimizer Mode, Advanced ECC Mode, Mirror Mode, Spare Mode, Spare with Advanced ECC Mode, Dell Fault Resilient Mode and Dell NUMA Fault Resilient Mode. This option is set to Optimizer Mode by default.</p> <p> NOTE: The Memory Operating Mode option can have different default and available options based on the memory configuration of your system.</p> <p> NOTE: The Dell Fault Resilient Mode option establishes an area of memory that is fault resilient. This mode can be used by an operating system that supports the feature to load critical applications or enables the operating system kernel to maximize system availability.</p>
Node Interleaving	Specifies if the Non-Uniform Memory Architecture (NUMA) is supported. If this field is set to Enabled , memory interleaving is supported if a symmetric memory configuration is installed. If the field is set to Disabled , the system supports NUMA (asymmetric) memory configurations. This option is set to Disabled by default.
Snoop Mode	Specifies the Snoop Mode options. The Snoop Mode options available are Home Snoop , Early Snoop , and Cluster on Die . This option is set to Early Snoop by default. This field is available only when the Node Interleaving is set to Disabled .

Related references

[Memory Settings](#) on page 46

Related tasks

[Viewing Memory Settings](#) on page 46

Processor Settings

You can use the **Processor Settings** screen to view the processor settings, and perform specific functions such as enabling virtualization technology, hardware prefetcher, and logical processor idling.

Related references

[Processor Settings details](#) on page 48

[System BIOS](#) on page 35

Related tasks

[Viewing Processor Settings](#) on page 48

Viewing Processor Settings

To view the **Processor Settings** screen, perform the following steps:

Steps

1. Turn on, or restart your system.
2. Press F2 immediately after you see the following message:

```
F2 = System Setup
```

 **NOTE:** If your operating system begins to load before you press F2, wait for the system to finish booting, and then restart your system and try again.

3. On the **System Setup Main Menu** screen, click **System BIOS**.
4. On the **System BIOS** screen, click **Processor Settings**.

Related references

[Processor Settings](#) on page 48



[Processor Settings details](#) on page 48

Processor Settings details

About this task

The **Processor Settings** screen details are explained as follows:

Option	Description
Logical Processor	Enables or disables the logical processors and displays the number of logical processors. If this option is set to Enabled , the BIOS displays all the logical processors. If this option is set to Disabled , the BIOS displays only one logical processor per core. This option is set to Enabled by default.
QPI Speed	Enables you to control QuickPath Interconnect data rate settings.
Alternate RTID (Requestor Transaction ID) Setting	Modifies Requestor Transaction IDs, which are QPI resources. This option is set to Disabled by default.  NOTE: Enabling this option may negatively impact the overall system performance.
Virtualization Technology	Enables or disables the additional hardware capabilities provided for virtualization. This option is set to Enabled by default.
Address Translation Service (ATS)	Defines the Address Translation Cache (ATC) for devices to cache the DMA transactions. This option provides an interface between CPU and DMA Memory Management to a chipset's Address Translation and Protection Table to translate DMA addresses to host addresses. This option is set to Enabled by default.

Option	Description
Adjacent Cache Line Prefetch	Optimizes the system for applications that need high utilization of sequential memory access. This option is set to Enabled by default. You can disable this option for applications that need high utilization of random memory access.
Hardware Prefetcher	Enables or disables the hardware prefetcher. This option is set to Enabled by default.
DCU Streamer Prefetcher	Enables or disables the Data Cache Unit (DCU) streamer prefetcher. This option is set to Enabled by default.
DCU IP Prefetcher	Enables or disables the Data Cache Unit (DCU) IP prefetcher. This option is set to Enabled by default.
Execute Disable	Enables you to run the disable memory protection technology. This option is set to Enabled by default.
Logical Processor Idling	Enables you to improve the energy efficiency of a system. It uses the operating system core parking algorithm and parks some of the logical processors in the system which in turn allows the corresponding processor cores to transition into a lower power idle state. This option can only be enabled if the operating system supports it. It is set to Disabled by default.
Configurable TDP	Enables you to reconfigure the processor Thermal Design Power (TDP) levels during POST based on the power and thermal delivery capabilities of the system. TDP verifies the maximum heat the cooling system is needed to dissipate. This option is set to Nominal by default.  NOTE: This option is only available on certain stock keeping units (SKUs) of the processors.
X2Apic Mode	Enables or disables the X2Apic mode.
Dell Controlled Turbo	Controls the turbo engagement. Enable this option only when System Profile is set to Performance .  NOTE: Depending on the number of installed CPUs, there may be up to four processor listings.
Number of Cores per Processor	Controls the number of enabled cores in each processor. This option is set to All by default.
Processor 64-bit Support	Specifies if the processor(s) support 64-bit extensions.
Processor Core Speed	Specifies the maximum core frequency of the processor.
Processor 1	 NOTE: Depending on the number of CPUs, there may be up to four processors listed.

The following settings are displayed for each processor installed in the system:

Option	Description
Family-Model-Stepping	Specifies the family, model, and stepping of the processor as defined by Intel.
Brand	Specifies the brand name.
Level 2 Cache	Specifies the total L2 cache.
Level 3 Cache	Specifies the total L3 cache.
Number of Cores	Specifies the number of cores per processor.

Related references

[Processor Settings](#) on page 48

Related tasks

[Viewing Processor Settings](#) on page 48

SATA Settings

You can use the **SATA Settings** screen to view the SATA settings of SATA devices and enable RAID on your system.

Related references

[System BIOS](#) on page 35

Related tasks

[SATA Settings details](#) on page 50

[Viewing SATA Settings](#) on page 50

Viewing SATA Settings

To view the **SATA Settings** screen, perform the following steps:

Steps

1. Turn on, or restart your system.
2. Press F2 immediately after you see the following message:

```
F2 = System Setup
```

NOTE: If your operating system begins to load before you press F2, wait for the system to finish booting, and then restart your system and try again.

3. On the **System Setup Main Menu** screen, click **System BIOS**.
4. On the **System BIOS** screen, click **SATA Settings**.

Related references

[SATA Settings](#) on page 50

Related tasks

[SATA Settings details](#) on page 50

SATA Settings details

About this task

The **SATA Settings** screen details are explained as follows:

Option	Description
Embedded SATA	Enables the embedded SATA option to be set to Off , ATA , AHCI , or RAID modes. This option is set to AHCI by default.
Security Freeze Lock	Sends Security Freeze Lock command to the Embedded SATA drives during POST. This option is applicable only for ATA and AHCI modes.
Write Cache	Enables or disables the command for Embedded SATA drives during POST.
Port A	Sets the drive type of the selected device. For Embedded SATA settings in ATA mode, set this field to Auto to enable BIOS support. Set it to OFF to turn off BIOS support. For AHCI or RAID mode, BIOS support is always enabled.
Option	Description
Model	Specifies the drive model of the selected device.
Drive Type	Specifies the type of drive attached to the SATA port.

Option	Description								
	<table border="1"> <thead> <tr> <th>Option</th> <th>Description</th> </tr> </thead> <tbody> <tr> <td>Capacity</td> <td>Specifies the total capacity of the hard drive. This field is undefined for removable media devices such as optical drives.</td> </tr> </tbody> </table>	Option	Description	Capacity	Specifies the total capacity of the hard drive. This field is undefined for removable media devices such as optical drives.				
Option	Description								
Capacity	Specifies the total capacity of the hard drive. This field is undefined for removable media devices such as optical drives.								
Port B	<p>Sets the drive type of the selected device. For Embedded SATA settings in ATA mode, set this field to Auto to enable BIOS support. Set it to OFF to turn off BIOS support.</p> <p>For AHCI or RAID mode, BIOS support is always enabled.</p> <table border="1"> <thead> <tr> <th>Option</th> <th>Description</th> </tr> </thead> <tbody> <tr> <td>Model</td> <td>Specifies the drive model of the selected device.</td> </tr> <tr> <td>Drive Type</td> <td>Specifies the type of drive attached to the SATA port.</td> </tr> <tr> <td>Capacity</td> <td>Specifies the total capacity of the hard drive. This field is undefined for removable media devices such as optical drives.</td> </tr> </tbody> </table>	Option	Description	Model	Specifies the drive model of the selected device.	Drive Type	Specifies the type of drive attached to the SATA port.	Capacity	Specifies the total capacity of the hard drive. This field is undefined for removable media devices such as optical drives.
Option	Description								
Model	Specifies the drive model of the selected device.								
Drive Type	Specifies the type of drive attached to the SATA port.								
Capacity	Specifies the total capacity of the hard drive. This field is undefined for removable media devices such as optical drives.								
Port C	<p>Sets the drive type of the selected device. For Embedded SATA settings in ATA mode, set this field to Auto to enable BIOS support. Set it to OFF to turn off BIOS support.</p> <p>For AHCI or RAID mode, BIOS support is always enabled.</p> <table border="1"> <thead> <tr> <th>Option</th> <th>Description</th> </tr> </thead> <tbody> <tr> <td>Model</td> <td>Specifies the drive model of the selected device.</td> </tr> <tr> <td>Drive Type</td> <td>Specifies the type of drive attached to the SATA port.</td> </tr> <tr> <td>Capacity</td> <td>Specifies the total capacity of the hard drive. This field is undefined for removable media devices such as optical drives.</td> </tr> </tbody> </table>	Option	Description	Model	Specifies the drive model of the selected device.	Drive Type	Specifies the type of drive attached to the SATA port.	Capacity	Specifies the total capacity of the hard drive. This field is undefined for removable media devices such as optical drives.
Option	Description								
Model	Specifies the drive model of the selected device.								
Drive Type	Specifies the type of drive attached to the SATA port.								
Capacity	Specifies the total capacity of the hard drive. This field is undefined for removable media devices such as optical drives.								
Port D	<p>Sets the drive type of the selected device. For Embedded SATA settings in ATA mode, set this field to Auto to enable BIOS support. Set it to OFF to turn off BIOS support.</p> <p>For AHCI or RAID mode, BIOS support is always enabled.</p> <table border="1"> <thead> <tr> <th>Option</th> <th>Description</th> </tr> </thead> <tbody> <tr> <td>Model</td> <td>Specifies the drive model of the selected device.</td> </tr> <tr> <td>Drive Type</td> <td>Specifies the type of drive attached to the SATA port.</td> </tr> <tr> <td>Capacity</td> <td>Specifies the total capacity of the hard drive. This field is undefined for removable media devices such as optical drives.</td> </tr> </tbody> </table>	Option	Description	Model	Specifies the drive model of the selected device.	Drive Type	Specifies the type of drive attached to the SATA port.	Capacity	Specifies the total capacity of the hard drive. This field is undefined for removable media devices such as optical drives.
Option	Description								
Model	Specifies the drive model of the selected device.								
Drive Type	Specifies the type of drive attached to the SATA port.								
Capacity	Specifies the total capacity of the hard drive. This field is undefined for removable media devices such as optical drives.								
Port E	<p>Sets the drive type of the selected device. For Embedded SATA settings in ATA mode, set this field to Auto to enable BIOS support. Set it to OFF to turn off BIOS support.</p> <p>For AHCI or RAID mode, BIOS support is always enabled.</p> <table border="1"> <thead> <tr> <th>Option</th> <th>Description</th> </tr> </thead> <tbody> <tr> <td>Model</td> <td>Specifies the drive model of the selected device.</td> </tr> <tr> <td>Drive Type</td> <td>Specifies the type of drive attached to the SATA port.</td> </tr> <tr> <td>Capacity</td> <td>Specifies the total capacity of the hard drive. This field is undefined for removable media devices such as optical drives.</td> </tr> </tbody> </table>	Option	Description	Model	Specifies the drive model of the selected device.	Drive Type	Specifies the type of drive attached to the SATA port.	Capacity	Specifies the total capacity of the hard drive. This field is undefined for removable media devices such as optical drives.
Option	Description								
Model	Specifies the drive model of the selected device.								
Drive Type	Specifies the type of drive attached to the SATA port.								
Capacity	Specifies the total capacity of the hard drive. This field is undefined for removable media devices such as optical drives.								
Port F	<p>Sets the drive type of the selected device. For Embedded SATA settings in ATA mode, set this field to Auto to enable BIOS support. Set it to OFF to turn off BIOS support.</p> <p>For AHCI or RAID mode, BIOS support is always enabled.</p> <table border="1"> <thead> <tr> <th>Option</th> <th>Description</th> </tr> </thead> <tbody> <tr> <td>Model</td> <td>Specifies the drive model of the selected device.</td> </tr> </tbody> </table>	Option	Description	Model	Specifies the drive model of the selected device.				
Option	Description								
Model	Specifies the drive model of the selected device.								

Option	Description								
	<table border="0"> <thead> <tr> <th style="text-align: left;">Option</th> <th style="text-align: left;">Description</th> </tr> </thead> <tbody> <tr> <td>Drive Type</td> <td>Specifies the type of drive attached to the SATA port.</td> </tr> <tr> <td>Capacity</td> <td>Specifies the total capacity of the hard drive. This field is undefined for removable media devices such as optical drives.</td> </tr> </tbody> </table>	Option	Description	Drive Type	Specifies the type of drive attached to the SATA port.	Capacity	Specifies the total capacity of the hard drive. This field is undefined for removable media devices such as optical drives.		
Option	Description								
Drive Type	Specifies the type of drive attached to the SATA port.								
Capacity	Specifies the total capacity of the hard drive. This field is undefined for removable media devices such as optical drives.								
Port G	<p>Sets the drive type of the selected device. For Embedded SATA settings in ATA mode, set this field to Auto to enable BIOS support. Set it to OFF to turn off BIOS support.</p> <p>For AHCI or RAID mode, BIOS support is always enabled.</p> <table border="0"> <thead> <tr> <th style="text-align: left;">Option</th> <th style="text-align: left;">Description</th> </tr> </thead> <tbody> <tr> <td>Model</td> <td>Specifies the drive model of the selected device.</td> </tr> <tr> <td>Drive Type</td> <td>Specifies the type of drive attached to the SATA port.</td> </tr> <tr> <td>Capacity</td> <td>Specifies the total capacity of the hard drive. This field is undefined for removable media devices such as optical drives.</td> </tr> </tbody> </table>	Option	Description	Model	Specifies the drive model of the selected device.	Drive Type	Specifies the type of drive attached to the SATA port.	Capacity	Specifies the total capacity of the hard drive. This field is undefined for removable media devices such as optical drives.
Option	Description								
Model	Specifies the drive model of the selected device.								
Drive Type	Specifies the type of drive attached to the SATA port.								
Capacity	Specifies the total capacity of the hard drive. This field is undefined for removable media devices such as optical drives.								
Port H	<p>Sets the drive type of the selected device. For Embedded SATA settings in ATA mode, set this field to Auto to enable BIOS support. Set it to OFF to turn off BIOS support.</p> <p>For AHCI or RAID mode, BIOS support is always enabled.</p> <table border="0"> <thead> <tr> <th style="text-align: left;">Option</th> <th style="text-align: left;">Description</th> </tr> </thead> <tbody> <tr> <td>Model</td> <td>Specifies the drive model of the selected device.</td> </tr> <tr> <td>Drive Type</td> <td>Specifies the type of drive attached to the SATA port.</td> </tr> <tr> <td>Capacity</td> <td>Specifies the total capacity of the hard drive. This field is undefined for removable media devices such as optical drives.</td> </tr> </tbody> </table>	Option	Description	Model	Specifies the drive model of the selected device.	Drive Type	Specifies the type of drive attached to the SATA port.	Capacity	Specifies the total capacity of the hard drive. This field is undefined for removable media devices such as optical drives.
Option	Description								
Model	Specifies the drive model of the selected device.								
Drive Type	Specifies the type of drive attached to the SATA port.								
Capacity	Specifies the total capacity of the hard drive. This field is undefined for removable media devices such as optical drives.								
Port I	<p>Sets the drive type of the selected device. For Embedded SATA settings in ATA mode, set this field to Auto to enable BIOS support. Set it to OFF to turn off BIOS support.</p> <p>For AHCI or RAID mode, BIOS support is always enabled.</p> <table border="0"> <thead> <tr> <th style="text-align: left;">Option</th> <th style="text-align: left;">Description</th> </tr> </thead> <tbody> <tr> <td>Model</td> <td>Specifies the drive model of the selected device.</td> </tr> <tr> <td>Drive Type</td> <td>Specifies the type of drive attached to the SATA port.</td> </tr> <tr> <td>Capacity</td> <td>Specifies the total capacity of the hard drive. This field is undefined for removable media devices such as optical drives.</td> </tr> </tbody> </table>	Option	Description	Model	Specifies the drive model of the selected device.	Drive Type	Specifies the type of drive attached to the SATA port.	Capacity	Specifies the total capacity of the hard drive. This field is undefined for removable media devices such as optical drives.
Option	Description								
Model	Specifies the drive model of the selected device.								
Drive Type	Specifies the type of drive attached to the SATA port.								
Capacity	Specifies the total capacity of the hard drive. This field is undefined for removable media devices such as optical drives.								
Port J	<p>Sets the drive type of the selected device. For Embedded SATA settings in ATA mode, set this field to Auto to enable BIOS support. Set it to OFF to turn off BIOS support.</p> <p>For AHCI or RAID mode, BIOS support is always enabled.</p> <table border="0"> <thead> <tr> <th style="text-align: left;">Option</th> <th style="text-align: left;">Description</th> </tr> </thead> <tbody> <tr> <td>Model</td> <td>Specifies the drive model of the selected device.</td> </tr> <tr> <td>Drive Type</td> <td>Specifies the type of drive attached to the SATA port.</td> </tr> <tr> <td>Capacity</td> <td>Specifies the total capacity of the hard drive. This field is undefined for removable media devices such as optical drives.</td> </tr> </tbody> </table>	Option	Description	Model	Specifies the drive model of the selected device.	Drive Type	Specifies the type of drive attached to the SATA port.	Capacity	Specifies the total capacity of the hard drive. This field is undefined for removable media devices such as optical drives.
Option	Description								
Model	Specifies the drive model of the selected device.								
Drive Type	Specifies the type of drive attached to the SATA port.								
Capacity	Specifies the total capacity of the hard drive. This field is undefined for removable media devices such as optical drives.								

Related references

[SATA Settings](#) on page 50

Related tasks

[Viewing SATA Settings](#) on page 50

Integrated Devices

You can use the **Integrated Devices** screen to view and configure the settings of all integrated devices including the video controller, integrated RAID controller, and the USB ports.

Related references

[System BIOS](#) on page 35

Related tasks

[Integrated Devices details](#) on page 53

[Viewing Integrated Devices](#) on page 53

Viewing Integrated Devices

To view the **Integrated Devices** screen, perform the following steps:

Steps

1. Turn on, or restart your system.
2. Press F2 immediately after you see the following message:

```
F2 = System Setup
```

 **NOTE:** If your operating system begins to load before you press F2, wait for the system to finish booting, and then restart your system and try again.

3. On the **System Setup Main Menu** screen, click **System BIOS**.
4. On the **System BIOS** screen, click **Integrated Devices**.

Related references

[Integrated Devices](#) on page 53

Related tasks

[Integrated Devices details](#) on page 53

Integrated Devices details

About this task

The **Integrated Devices** screen details are explained as follows:

Option	Description
USB 3.0 Setting	Enables or disables the USB 3.0 support. Enable this option only if your operating system supports USB 3.0. If you disable this option, devices operate at USB 2.0 speed. USB 3.0 is enabled by default.
User Accessible USB Ports	Enables or disables the USB ports. Selecting Only Back Ports On disables the front USB ports, selecting All Ports Off disables all USB ports. The USB keyboard and mouse operate during boot process in certain operating systems. After the boot process is complete, the USB keyboard and mouse do not work if the ports are disabled.  NOTE: Selecting Only Back Ports On and All Ports Off disables the USB management port and also restricts access to iDRAC features.
Internal USB Port	Enables or disables the internal USB port. This option is set to Enabled by default.
Integrated RAID Controller	Enables or disables the integrated RAID controller. This option is set to Enabled by default.

Option	Description
Integrated Network Card 1	Enables or disables the integrated network card.
Embedded NIC1 and NIC2	<p> NOTE: The Embedded NIC1 and NIC2 options are only available on systems that do not have Integrated Network Card 1.</p> <p>Enables or disables the Embedded NIC1 and NIC2 options. If set to Disabled, the NIC may still be available for shared network access by the embedded management controller. The embedded NIC1 and NIC2 options are only available on systems that do not have Network Daughter Cards (NDCs). The Embedded NIC1 and NIC2 option is mutually exclusive with the Integrated Network Card 1 option. Configure the Embedded NIC1 and NIC2 option by using the NIC management utilities of the system.</p>
I/OAT DMA Engine	Enables or disables the I/OAT option. Enable only if the hardware and software support the feature.
I/O Snoop Holdoff Response	Selects the number of cycles PCI I/O can withhold snoop requests from the CPU, to allow time to complete its own write to LLC. This setting can help improve performance on workloads where throughput and latency are critical.
Embedded Video Controller	Enables or disables the Embedded Video Controller option. This option is set to Enabled by default.
Current State of Embedded Video Controller	Displays the current state of the embedded video controller. The Current State of Embedded Video Controller option is a read-only field. If the Embedded Video Controller is the only display capability in the system (that is, no add-in graphics card is installed), then the Embedded Video Controller is automatically used as the primary display even if the Embedded Video Controller setting is set to Disabled .
SR-IOV Global Enable	Enables or disables the BIOS configuration of Single Root I/O Virtualization (SR-IOV) devices. This option is set to Disabled by default.
OS Watchdog Timer	If your system stops responding, this watchdog timer aids in the recovery of your operating system. When this option is set to Enabled , the operating system initializes the timer. When this option is set to Disabled (the default), the timer does not have any effect on the system.
Memory Mapped I/O above 4 GB	Enables or disables the support for PCIe devices that need large amounts of memory. This option is set to Enabled by default.
Slot Disablement	Enables or disables the available PCIe slots on your system. The slot disablement feature controls the configuration of PCIe cards installed in the specified slot. Slots must be disabled only when the installed peripheral card prevents booting into the operating system or causes delays in system startup. If the slot is disabled, both the Option ROM and UEFI drivers are disabled.

Related references

[Integrated Devices](#) on page 53

Related tasks

[Viewing Integrated Devices](#) on page 53

Serial Communication

You can use the **Serial Communication** screen to view the properties of the serial communication port.

Related references

[System BIOS](#) on page 35

Related tasks

[Serial Communication details](#) on page 55

[Viewing Serial Communication](#) on page 55

Viewing Serial Communication

To view the **Serial Communication** screen, perform the following steps:

Steps

1. Turn on, or restart your system.
2. Press F2 immediately after you see the following message:

```
F2 = System Setup
```

NOTE: If your operating system begins to load before you press F2, wait for the system to finish booting, and then restart your system and try again.

3. On the **System Setup Main Menu** screen, click **System BIOS**.
4. On the **System BIOS** screen, click **Serial Communication**.

Related references

[Serial Communication](#) on page 54

Related tasks

[Serial Communication details](#) on page 55

Serial Communication details

About this task

The **Serial Communication** screen details are explained as follows:

Option	Description
Serial Communication	Selects serial communication devices (Serial Device 1 and Serial Device 2) in BIOS. BIOS console redirection can also be enabled and the port address can be specified. This option is set to Auto by default.
Serial Port Address	Enables you to set the port address for serial devices. This option is set to Serial Device 1=COM2, Serial Device 2=COM1 by default. NOTE: You can use only Serial Device 2 for the Serial Over LAN (SOL) feature. To use console redirection by SOL, configure the same port address for console redirection and the serial device. NOTE: Every time the system boots, the BIOS syncs the serial MUX setting saved in iDRAC. The serial MUX setting can independently be changed in iDRAC. Loading the BIOS default settings from within the BIOS setup utility may not always revert the serial MUX setting to the default setting of Serial Device 1.
External Serial Connector	Enables you to associate the External Serial Connector to Serial Device 1, Serial Device 2, or the Remote Access Device by using this option. NOTE: Only Serial Device 2 can be used for Serial Over LAN (SOL). To use console redirection by SOL, configure the same port address for console redirection and the serial device. NOTE: Every time the system boots, the BIOS syncs the serial MUX setting saved in iDRAC. The serial MUX setting can independently be changed in iDRAC. Loading the BIOS default settings from within the BIOS setup utility may not always revert this setting to the default setting of Serial Device 1.
Failsafe Baud Rate	Specifies the failsafe baud rate for console redirection. The BIOS attempts to determine the baud rate automatically. This failsafe baud rate is used only if the attempt fails, and the value must not be changed. This option is set to 115200 by default.

Option	Description
Remote Terminal Type	Sets the remote console terminal type. This option is set to VT 100/VT 220 by default.
Redirection After Boot	Enables or disables the BIOS console redirection when the operating system is loaded. This option is set to Enabled by default.

Related references

[Serial Communication](#) on page 54

Related tasks

[Viewing Serial Communication](#) on page 55

System Profile Settings

You can use the **System Profile Settings** screen to enable specific system performance settings such as power management.

Related references

[System BIOS](#) on page 35

Related tasks

[System Profile Settings details](#) on page 56

[Viewing System Profile Settings](#) on page 56

Viewing System Profile Settings

To view the **System Profile Settings** screen, perform the following steps:

Steps

1. Turn on, or restart your system.
2. Press F2 immediately after you see the following message:

```
F2 = System Setup
```

NOTE: If your operating system begins to load before you press F2, wait for the system to finish booting, and then restart your system and try again.

3. On the **System Setup Main Menu** screen, click **System BIOS**.
4. On the **System BIOS** screen, click **System Profile Settings**.

Related references

[System Profile Settings](#) on page 56

Related tasks

[System Profile Settings details](#) on page 56

System Profile Settings details

About this task

The **System Profile Settings** screen details are explained as follows:

Option	Description
System Profile	<p>Sets the system profile. If you set the System Profile option to a mode other than Custom, the BIOS automatically sets the rest of the options. You can only change the rest of the options if the mode is set to Custom. This option is set to Performance Per Watt Optimized (DAPC) by default. DAPC is Dell Active Power Controller.</p> <p> NOTE: All the parameters on the system profile setting screen are available only when the System Profile option is set to Custom.</p>
CPU Power Management	Sets the CPU power management. This option is set to System DBPM (DAPC) by default.
Memory Frequency	Sets the speed of the memory. You can select Maximum Performance , Maximum Reliability , or a specific speed.
Turbo Boost	Enables or disables the processor to operate in the turbo boost mode. This option is set to Enabled by default.
Energy Efficient Turbo	<p>Enables or disables the Energy Efficient Turbo option.</p> <p>Energy Efficient Turbo (EET) is a mode of operation where a processor's core frequency is adjusted to be within the turbo range based on workload.</p>
C1E	Enables or disables the processor to switch to a minimum performance state when it is idle. This option is set to Enabled by default.
C States	Enables or disables the processor to operate in all available power states. This option is set to Enabled by default.
Collaborative CPU Performance Control	Enables or disables the CPU power management option. When set to Enabled , the CPU power management is controlled by the OS DBPM and the System DBPM (DAPC). This option is set to Disabled by default.
Memory Patrol Scrub	Sets the memory patrol scrub frequency. This option is set to Standard by default.
Memory Refresh Rate	Sets the memory refresh rate to either 1x or 2x. This option is set to 1x by default.
Uncore Frequency	<p>Enables you to select the Processor Uncore Frequency option.</p> <p>Dynamic mode enables the processor to optimize power resources across the cores and uncore during runtime. The optimization of the uncore frequency to either save power or optimize performance is influenced by the setting of the Energy Efficiency Policy option.</p>
Energy Efficient Policy	<p>Enables you to select the Energy Efficient Policy option.</p> <p>The CPU uses the setting to manipulate the internal behavior of the processor and determines whether to target higher performance or better power savings.</p>
Number of Turbo Boost Enabled Cores for Processor 1	<p> NOTE: If there are two processors installed in the system, you see an entry for Number of Turbo Boost Enabled Cores for Processor 2.</p> <p>Controls the number of turbo boost enabled cores for processor 1. The maximum number of cores is enabled by default.</p>
Monitor/Mwait	<p>Enables the Monitor/Mwait instructions in the processor. This option is set to Enabled for all system profiles, except Custom by default.</p> <p> NOTE: This option can be disabled only if the C States option in the Custom mode is set to disabled.</p> <p> NOTE: When C States is set to Enabled in the Custom mode, changing the Monitor/Mwait setting does not impact the system power or performance.</p>

Related references

[System Profile Settings](#) on page 56

Related tasks

[Viewing System Profile Settings](#) on page 56

Miscellaneous Settings

You can use the **Miscellaneous Settings** screen to perform specific functions such as updating the asset tag and changing the system date and time.

Related references

[System BIOS](#) on page 35

Related tasks

[Miscellaneous Settings details](#) on page 58

[Viewing Miscellaneous Settings](#) on page 58

Viewing Miscellaneous Settings

To view the **Miscellaneous Settings** screen, perform the following steps:

Steps

1. Turn on, or restart your system.
2. Press F2 immediately after you see the following message:

```
F2 = System Setup
```

 **NOTE:** If your operating system begins to load before you press F2, wait for the system to finish booting, and then restart your system and try again.

3. On the **System Setup Main Menu** screen, click **System BIOS**.
4. On the **System BIOS** screen, click **Miscellaneous Settings**.

Related references

[Miscellaneous Settings](#) on page 58

Related tasks

[Miscellaneous Settings details](#) on page 58

Miscellaneous Settings details

About this task

The **Miscellaneous Settings** screen details are explained as follows:

Option	Description
System Time	Enables you to set the time on the system.
System Date	Enables you to set the date on the system.
Asset Tag	Specifies the asset tag and enables you to modify it for security and tracking purposes.
Keyboard NumLock	Enables you to set whether the system boots with the NumLock enabled or disabled. This option is set to On by default.  NOTE: This option does not apply to 84-key keyboards.
F1/F2 Prompt on Error	Enables or disables the F1/F2 prompt on error. This option is set to Enabled by default. The F1/F2 prompt also includes keyboard errors.

Option	Description
Load Legacy Video Option ROM	Enables you to determine whether the system BIOS loads the legacy video (INT 10H) option ROM from the video controller. Selecting Enabled in the operating system does not support UEFI video output standards. This field is available only for UEFI boot mode. You cannot set the option to Enabled if UEFI Secure Boot mode is enabled.
In-System Characterization	<p>Enables or disables In-System Characterization. This option is set to Disabled by default. The two other options are Enabled and Enabled - No Reboot.</p> <p> NOTE: The default setting for In-System Characterization is subject to change in future BIOS releases.</p> <p>When enabled, In-System Characterization (ISC) executes during POST upon detecting relevant changes in system configuration to optimize system power and performance. ISC takes about 20 seconds to execute, and system reset is needed for ISC results to be applied. The Enabled - No Reboot option executes ISC and continues without applying ISC results until the next time system reset occurs. The Enabled option executes ISC and forces an immediate system reset so that ISC results can be applied. It takes the system longer to be ready due to the forced system reset. When disabled, ISC does not execute.</p>

Related references

[Miscellaneous Settings](#) on page 58

Related tasks

[Viewing Miscellaneous Settings](#) on page 58

iDRAC Settings utility

The iDRAC settings utility is an interface to set up and configure the iDRAC parameters by using UEFI. You can enable or disable various iDRAC parameters by using the iDRAC settings utility.

 **NOTE:** Accessing some of the features on the iDRAC settings utility needs the iDRAC Enterprise License upgrade.

For more information about using iDRAC, see *Dell Integrated Dell Remote Access Controller User's Guide* at Dell.com/idracmanuals.

Related concepts

[Device Settings](#) on page 60

Related references

[System BIOS](#) on page 35

Related tasks

[Entering the iDRAC Settings utility](#) on page 59

[Changing the thermal settings](#) on page 60

Entering the iDRAC Settings utility

Steps

1. Turn on or restart the managed system.
2. Press F2 during Power-on Self-test (POST).
3. On the **System Setup Main Menu** page, click **iDRAC Settings**.
The **iDRAC Settings** screen is displayed.

Related references

[iDRAC Settings utility](#) on page 59

Changing the thermal settings

The iDRAC settings utility enables you to select and customize the thermal control settings for your system.

1. Click **iDRAC Settings > Thermal**.
2. Under **SYSTEM THERMAL PROFILE > Thermal Profile**, select one of the following options:
 - Default Thermal Profile Settings
 - Maximum Performance (Performance Optimized)
 - Minimum Power (Performance per Watt Optimized)
3. Under **USER COOLING OPTIONS**, set the **Fan Speed Offset**, **Minimum Fan Speed**, and **Custom Minimum Fan Speed**.
4. Click **Back > Finish > Yes**.

Related references

[iDRAC Settings utility](#) on page 59

Device Settings

Device Settings enables you to configure device parameters.

Related references

[System BIOS](#) on page 35

Dell Lifecycle Controller

Dell Lifecycle Controller (LC) provides advanced embedded system management capabilities including system deployment, configuration, update, maintenance, and diagnosis. LC is delivered as part of the iDRAC out-of-band solution and Dell EMC system embedded Unified Extensible Firmware Interface (UEFI) applications.

Related references

[Embedded systems management](#) on page 60

Embedded systems management

The Dell Lifecycle Controller provides advanced embedded systems management throughout the lifecycle of the system. The Dell Lifecycle Controller can be started during the boot sequence and can function independently of the operating system.

 **NOTE:** Certain platform configurations may not support the full set of features provided by the Dell Lifecycle Controller.

For more information about setting up the Dell Lifecycle Controller, configuring hardware and firmware, and deploying the operating system, see the Dell Lifecycle Controller documentation at [Dell.com/idracmanuals](https://www.dell.com/idracmanuals).

Related references

[Dell Lifecycle Controller](#) on page 60

Boot Manager

The **Boot Manager** screen enables you to select boot options and diagnostic utilities.

Related references

[Boot Manager main menu](#) on page 61

[System BIOS](#) on page 35

Related tasks

[Viewing Boot Manager](#) on page 61

Viewing Boot Manager

To enter **Boot Manager**:

Steps

1. Turn on, or restart your system.
2. Press F11 when you see the following message:

```
F11 = Boot Manager
```

If your operating system begins to load before you press F11, allow the system to complete the booting, and then restart your system and try again.

Related references

[Boot Manager](#) on page 60

[Boot Manager main menu](#) on page 61

Boot Manager main menu

Menu item	Description
Continue Normal Boot	The system attempts to boot to devices starting with the first item in the boot order. If the boot attempt fails, the system continues with the next item in the boot order until the boot is successful or no more boot options are found.
One-shot Boot Menu	Enables you to access boot menu, where you can select a one-time boot device to boot from.
Launch System Setup	Enables you to access System Setup.
Launch Lifecycle Controller	Exits the Boot Manager and invokes the Dell Lifecycle Controller program.
System Utilities	Enables you to launch System Utilities menu such as System Diagnostics and UEFI shell.

Related references

[Boot Manager](#) on page 60

Related tasks

[Viewing Boot Manager](#) on page 61

One-shot BIOS boot menu

One-shot BIOS boot menu enables you to select a boot device to boot from.

Related references

[Boot Manager](#) on page 60

System Utilities

System Utilities contains the following utilities that can be launched:

- Launch Diagnostics
- BIOS/UEFI Update File Explorer
- Reboot System

 **NOTE:** Depending on the boot mode selected, you might have BIOS or UEFI Update File Explorer.

Related references

[Boot Manager](#) on page 60

PXE boot

You can use the Preboot Execution Environment (PXE) option to boot and configure the networked systems, remotely.

 **NOTE:** To access the **PXE boot** option, boot the system and then press F12. The system scans and displays the active networked systems.

Installing and removing system components

Topics:

- Safety instructions
- Before working inside your system
- After working inside your system
- Recommended tools
- Front bezel (optional)
- System cover
- Inside the system
- Processor expansion module (optional)
- Cooling shroud
- Cooling fans
- Cooling fan assembly
- System memory
- Processors and heat sinks
- Power supply units
- Integrated storage controller card
- Expansion cards and expansion card riser
- IDSDM
- Network daughter card
- Internal USB memory key (optional)
- System battery
- Hard drives
- Optical drive (optional)
- Hard drive backplane
- Control panel
- System board
- Trusted Platform Module

Safety instructions

 **NOTE:** Whenever you need to lift the system, get others to assist you. To avoid injury, do not attempt to lift the system by yourself.

 **WARNING:** Opening or removing the system cover while the system is powered on may expose you to a risk of electric shock.

 **CAUTION:** Do not operate the system without the cover for a duration exceeding five minutes.

 **CAUTION:** Many repairs may only be done by a certified service technician. You should only perform troubleshooting and simple repairs as authorized in your product documentation, or as directed by the online or telephone service and support team. Damage due to servicing that is not authorized by Dell is not covered by your warranty. Read and follow the safety instructions that are shipped with your product.

 **NOTE:** It is recommended that you always use an antistatic mat and antistatic strap while working on components inside the system.

 **NOTE:** To ensure proper operation and cooling, all bays in the system and system fans must be populated always with a component.

Before working inside your system

Prerequisites

Follow the safety guidelines listed in the Safety instructions section.

Steps

1. Turn off the system, including any attached peripherals.
2. Disconnect the system from the electrical outlet and disconnect the peripherals.
3. If installed, remove the front bezel.
4. If applicable, remove the system from the rack.
For more information, see the *Rack Installation* placemat at Dell.com/poweredge manuals.
5. Remove the system cover.

After working inside your system

Prerequisites

Follow the safety guidelines listed in the Safety instructions section.

Steps

1. Install the system cover.
2. If applicable, install the system into the rack.
For more information, see the *Rack Installation* placemat at Dell.com/poweredge manuals.
3. If removed, install the front bezel.
4. Reconnect the peripherals and connect the system to the electrical outlet.
5. Turn on the system, including any attached peripherals.

Related references

[Safety instructions](#) on page 63

Related tasks

[Installing the system cover](#) on page 67

Recommended tools

You need the following tools to perform the removal and installation procedures:

- Key to the bezel lock.
The key is needed only if your system includes a bezel.
- Phillips #2 screwdriver
- Wrist grounding strap

Front bezel (optional)

The front bezel is attached to the front side of the system and prevents accidents while removing the hard drive or when pressing the reset or power button. The front bezel can also be locked for additional security.

Removing the optional front bezel

Prerequisites

Follow the safety guidelines listed in the Safety instructions section.

Steps

1. Locate and remove the bezel key.

NOTE: The bezel key is attached to the back of the bezel.

2. Unlock the bezel by using the key.
3. Slide the release latch up, and pull the left end of the bezel.
4. Unhook the right end, and remove the bezel.

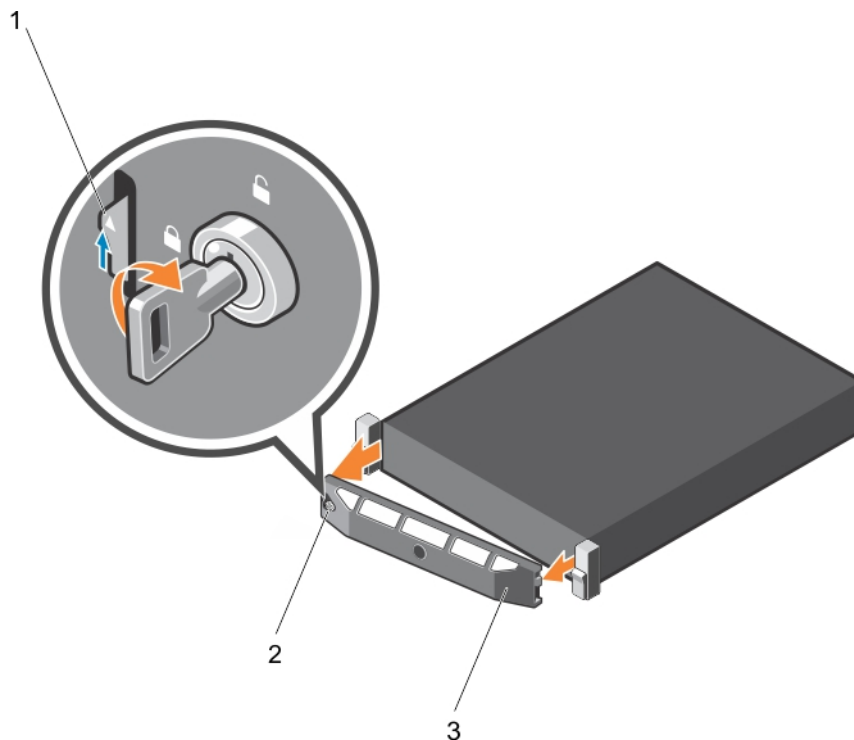

Figure 11. Removing the optional front bezel

- a. release latch
- b. bezel lock
- c. front bezel

Related references

[Safety instructions](#) on page 63

Related tasks

[Installing the optional front bezel](#) on page 66

Installing the optional front bezel

Prerequisites

Follow the safety guidelines listed in the Safety instructions section.

Steps

1. Locate and remove the bezel key.

NOTE: The bezel key is attached to the back of the bezel.

2. Hook the right end of the bezel onto the chassis.
3. Fit the free end of the bezel onto the system.
4. Lock the bezel by using the key.

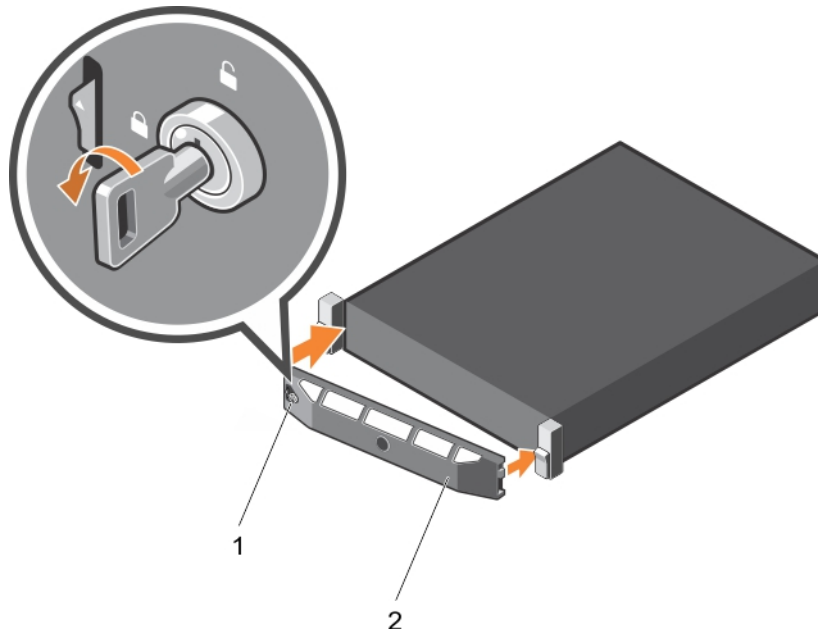

Figure 12. Installing the optional front bezel

- a. bezel lock
- b. front bezel

Related references

[Safety instructions](#) on page 63

System cover

The system cover protects the components inside the system and helps in maintaining air flow inside the system. Removing the system cover activates the intrusion switch.

Removing the system cover

Prerequisites

1. Follow the safety guidelines listed in the Safety instructions section.
2. If installed, remove the optional bezel.

Steps

1. Rotate the latch release lock counter clockwise to the unlocked position.
2. Lift the latch toward the back of the system.

The system cover slides back and the tabs on the system cover disengage from the slots on the chassis.

i **NOTE:** The position of the latch may vary depending on the configuration of your system.

3. Hold the cover on both sides, and lift the cover away from the system.

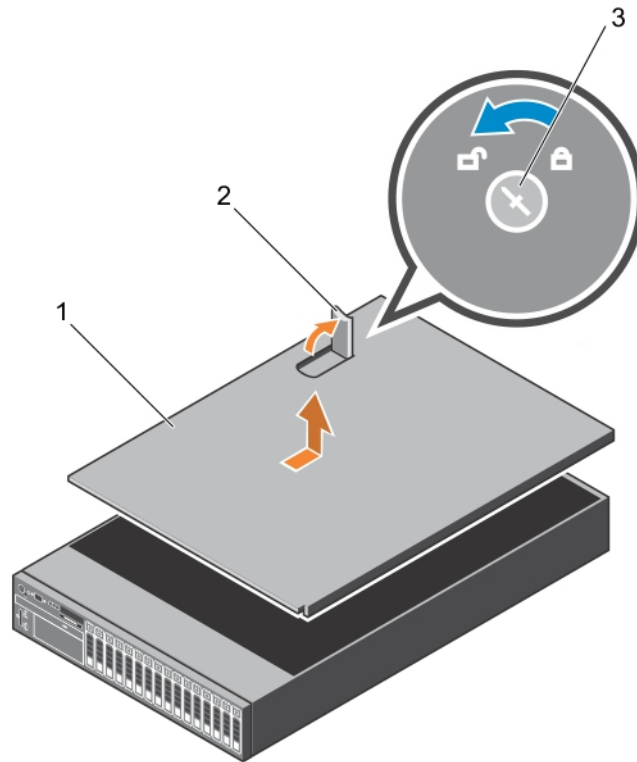

Figure 13. Removing the system cover

- a. system cover
- b. latch
- c. latch release lock

Next steps

1. Install the system cover.

Related references

[Safety instructions](#) on page 63

Related tasks

[Removing the optional front bezel](#) on page 65

[Installing the system cover](#) on page 67

Installing the system cover

Prerequisites

1. Follow the safety guidelines listed in the Safety instructions section.
2. Follow the procedure listed in the Before working inside your system section.

3. Ensure that all internal cables are connected and placed out of the way, and no tools or extra parts are left inside the system.

Steps

1. Align the slots on the system cover with the tabs on the chassis.
2. Push the system cover latch down.
The system cover slides forward and the slots on the system cover engage with the tabs on the chassis. The system cover latch locks into place when the system cover is completely engaged with the tabs on the chassis.
3. Rotate the latch release lock clockwise to the locked position.

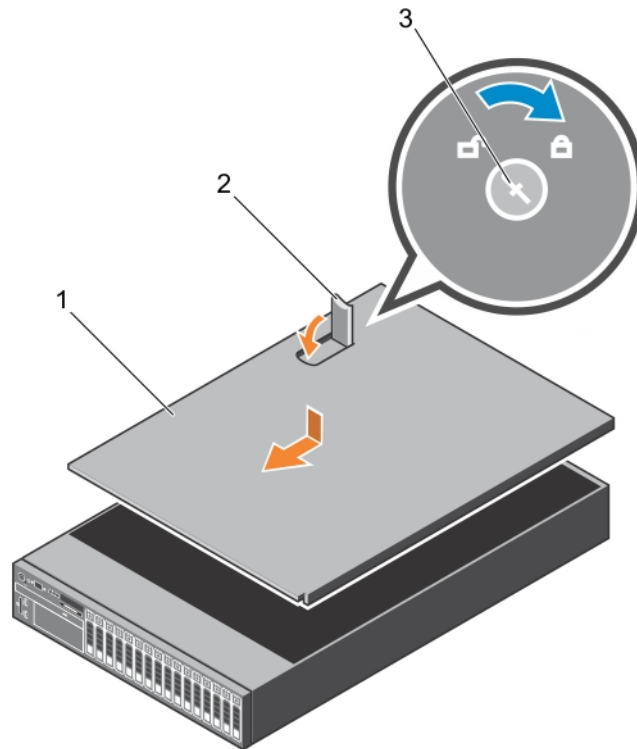

Figure 14. Installing the system cover

- a. system cover
- b. latch
- c. latch release lock

Next steps

1. If removed, install the front bezel.
2. Reconnect the peripherals and connect the system to the electrical outlet.
3. Turn on the system, including any attached peripherals.
4. Follow the procedure listed in the After working inside your system section.

Related references

[Safety instructions](#) on page 63

Related tasks

[Removing the optional front bezel](#) on page 65

Inside the system

CAUTION: Many repairs may only be done by a certified service technician. You should only perform troubleshooting and simple repairs as authorized in your product documentation, or as directed by the online or telephone service and support team. Damage due to servicing that is not authorized by Dell is not covered by your warranty. Read and follow the safety instructions that are shipped with your product.

NOTE: Components that are hot swappable are marked orange.

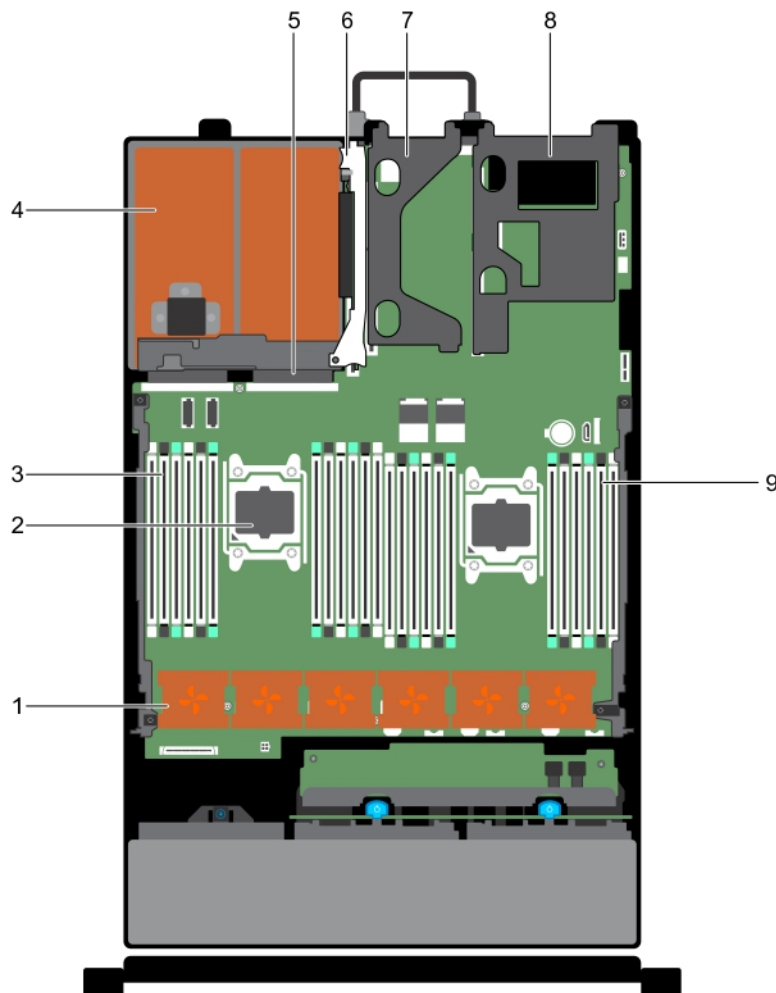

Figure 15. Inside the system — Two processor system

- 1. cooling fans (6)
- 2. processors (2)
- 3. DIMMs (12)
- 4. power supply unit (PSU) (2)
- 5. PSU connector
- 6. riser 3
- 7. riser 2
- 8. riser 1
- 9. DIMMs (12)

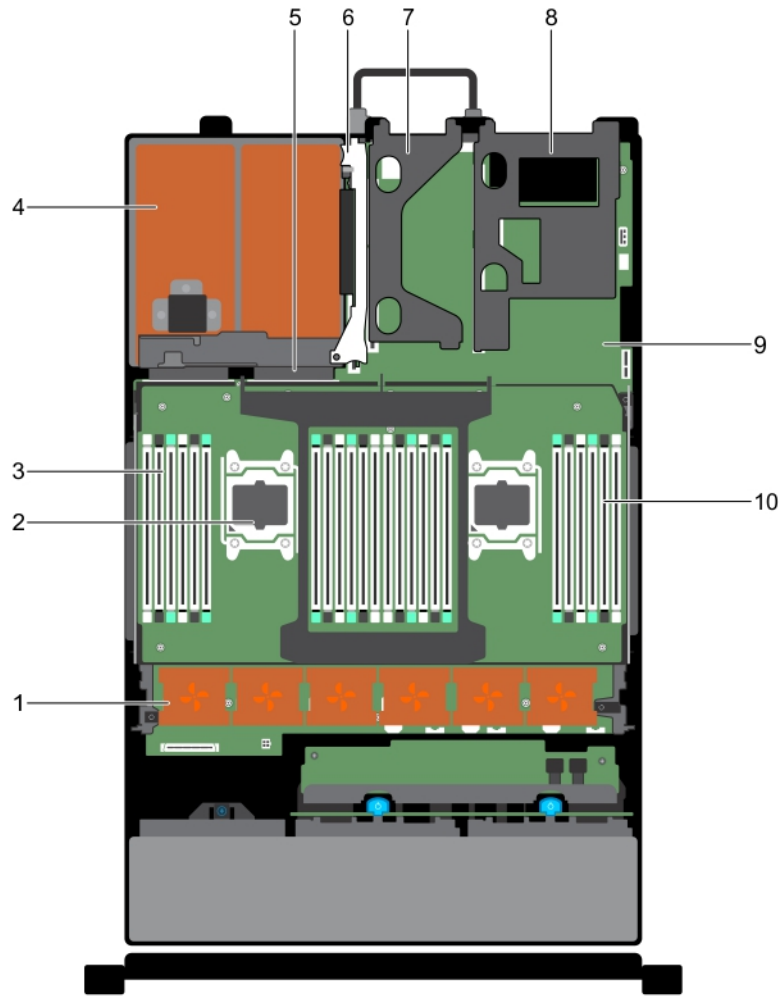

Figure 16. Inside the system — Four processor system with Processor expansion module (PEM)

- | | |
|---------------------------------------|--|
| 1. cooling fans (6) | 2. processors (4) |
| 3. DIMMs on system board and PEM (24) | 4. power supply unit (PSU) (2) |
| 5. PSU connector | 6. riser 3 |
| 7. riser 2 | 8. riser 1 |
| 9. System board | 10. DIMMs on system board and PEM (24) |

Processor expansion module (optional)

A processor expansion module (PEM) is present only in systems with four processors.

Removing the processor expansion module

Prerequisites

CAUTION: Many repairs may only be done by a certified service technician. You should only perform troubleshooting and simple repairs as authorized in your product documentation, or as directed by the online or telephone service and support team. Damage due to servicing that is not authorized by Dell is not covered by your warranty. Read and follow the safety instructions that are shipped with your product.

CAUTION: Do not lift the processor expansion module by grasping a memory module or heatsink.

1. Follow the safety guidelines listed in the Safety instructions section.
2. Follow the procedure listed in the Before working inside your system section.

Steps

1. Lift the release lever on the PEM until the PEM disengages from the chassis.

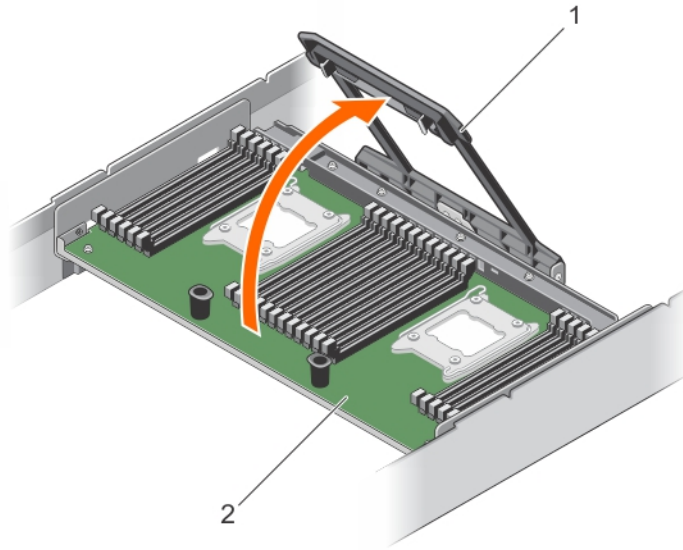

Figure 17. Disengaging the PEM

- a. processor expansion module
- b. release lever

2. Holding the release lever and a support pin, lift the PEM away from the chassis.

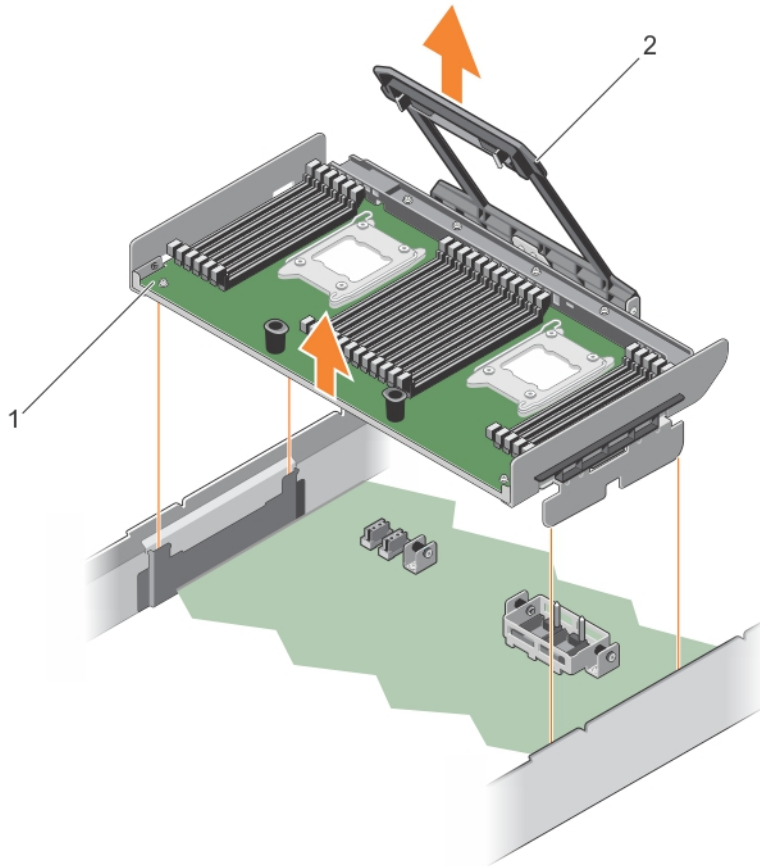

Figure 18. Removing the PEM

- a. processor expansion module
- b. release lever

3. If you are removing the PEM permanently, install a filler bracket over the QPI connector and install a cooling shroud.
 - NOTE:** You must install a filler bracket over the QPI connector to maintain the Federal Communications Commission (FCC) certification of the system. The filler bracket keeps dust and dirt out of the system.
4. To install the filler bracket, align the notches on the filler bracket with the standoffs on the QPI connector and press the filler bracket into place.

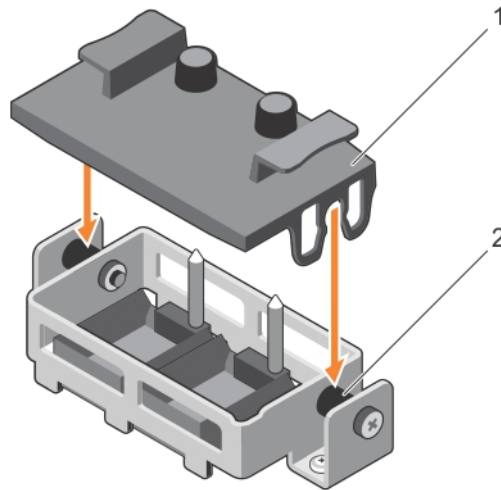

Figure 19. Installing the filler bracket on the QPI connector

- a. filler bracket
- b. standoff (2)

5. Install the PEM power connector cap.

Next steps

1. If applicable, install the cooling shroud.
 - CAUTION:** Never operate a two-processor system without the cooling shroud. The system may get overheated quickly, resulting in shutdown of the system and loss of data.
2. If applicable, install the PEM.
3. Follow the procedure listed in the After working inside your system section.

Related references

[Safety instructions](#) on page 63

Related tasks

[Before working inside your system](#) on page 64

[Removing the cooling shroud](#) on page 76

Installing the processor expansion module

Prerequisites

CAUTION: Many repairs may only be done by a certified service technician. You should only perform troubleshooting and simple repairs as authorized in your product documentation, or as directed by the online or telephone service and support team. Damage due to servicing that is not authorized by Dell is not covered by your warranty. Read and follow the safety instructions that are shipped with your product.

1. Before upgrading your system, download the latest system BIOS version from Dell.com/support and follow the instructions included in the compressed download file to install the update on your system.
 - NOTE:** You can update the system BIOS by using Dell Lifecycle Controller.
2. Follow the safety guidelines listed in the Safety instructions section.

3. Follow the procedure listed in the Before working inside your system section.
4. If applicable, remove the cooling shroud. Retain the cooling shroud for future use.

Steps

1. If applicable, remove the filler bracket. To remove the filler bracket, hold the tabs and lift the filler bracket away from the QPI connector.

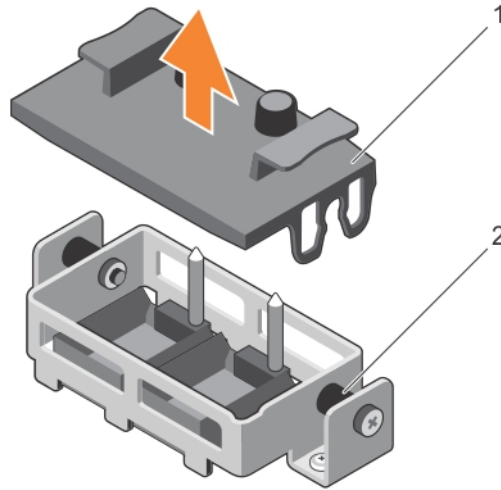

Figure 20. Removing the filler bracket from the QPI connector

- a. filler bracket
- b. standoff (2)

2. If applicable, remove the PEM power connector cap.
3. By holding the support pin and the release lever, align the alignment guides on the PEM with the alignment guides on the chassis, and lower the PEM into the chassis.

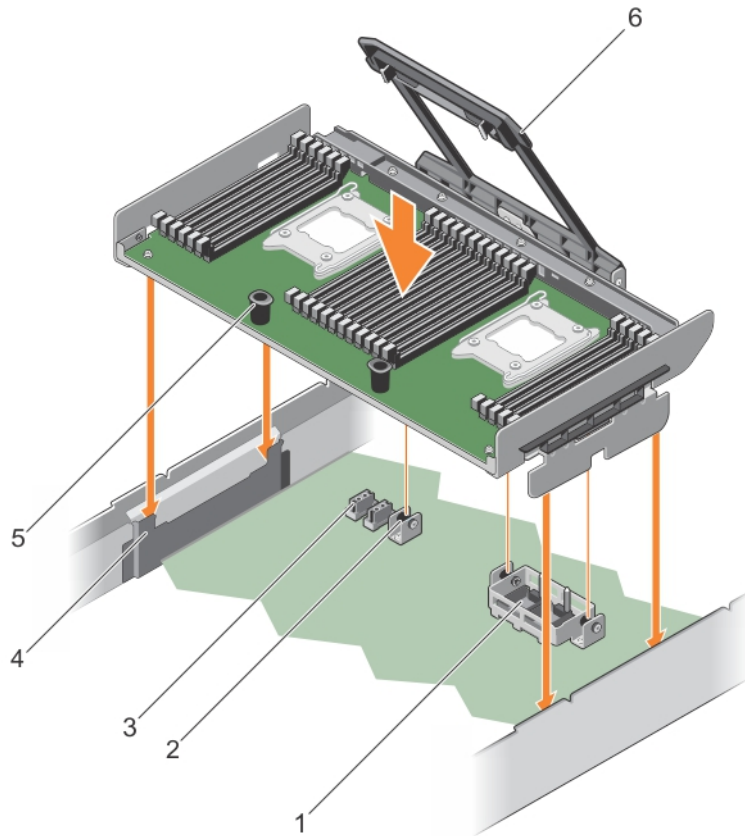

Figure 21. Installing the PEM

- | | |
|----------------------------|------------------------|
| 1. QPI connector | 2. standoff (3) |
| 3. PEM power connector (2) | 4. alignment guide (2) |
| 5. support pin (2) | 6. release lever |

4. Push the release lever towards the chassis until the PEM locks into place.

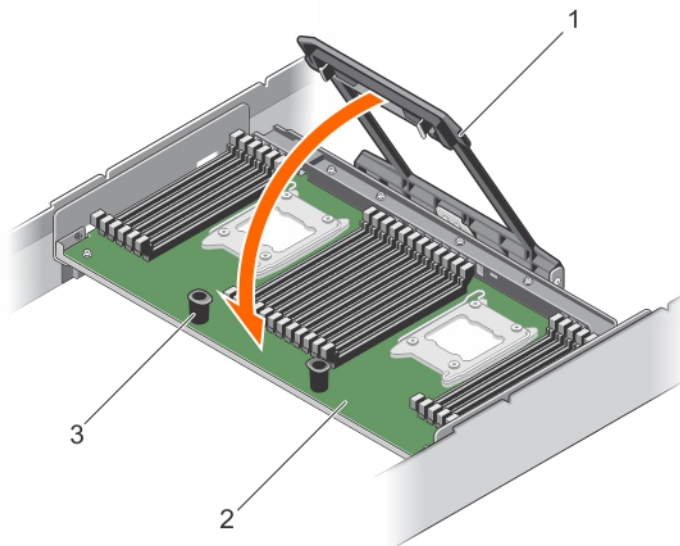

Figure 22. Securing the PEM on the chassis using the release lever

- a. processor expansion module
- b. support pin (2)
- c. release lever

Next steps

1. Follow the procedure listed in the After working inside your system section.
2. If you are installing the processor expansion module for the first time, press <F2> to enter the System Setup and check that the processor information matches the new system configuration.
3. Run the system diagnostics to verify that the new processors operate correctly. See Using System Diagnostics for available diagnostic tests.

Related references

[Safety instructions](#) on page 63

Related tasks

[Before working inside your system](#) on page 64

[After working inside your system](#) on page 64

Cooling shroud

The cooling shroud aerodynamically directs the airflow across the entire system. The airflow passes through all the critical parts of the system, where the vacuum pulls air across the entire surface area of the heat sink, thus allowing increased cooling.

Removing the cooling shroud

Prerequisites

CAUTION: Many repairs may only be done by a certified service technician. You should only perform troubleshooting and simple repairs as authorized in your product documentation, or as directed by the online or telephone service and support team. Damage due to servicing that is not authorized by Dell is not covered by your warranty. Read and follow the safety instructions that are shipped with your product.

CAUTION: Never operate a two-processor system without the cooling shroud. The system may get overheated quickly, resulting in shutdown of the system and loss of data.

1. Follow the safety guidelines listed in the Safety instructions section.
2. Follow the procedure listed in the Before working inside your system section.

Steps

Holding the touch points, lift the cooling shroud away from the system.

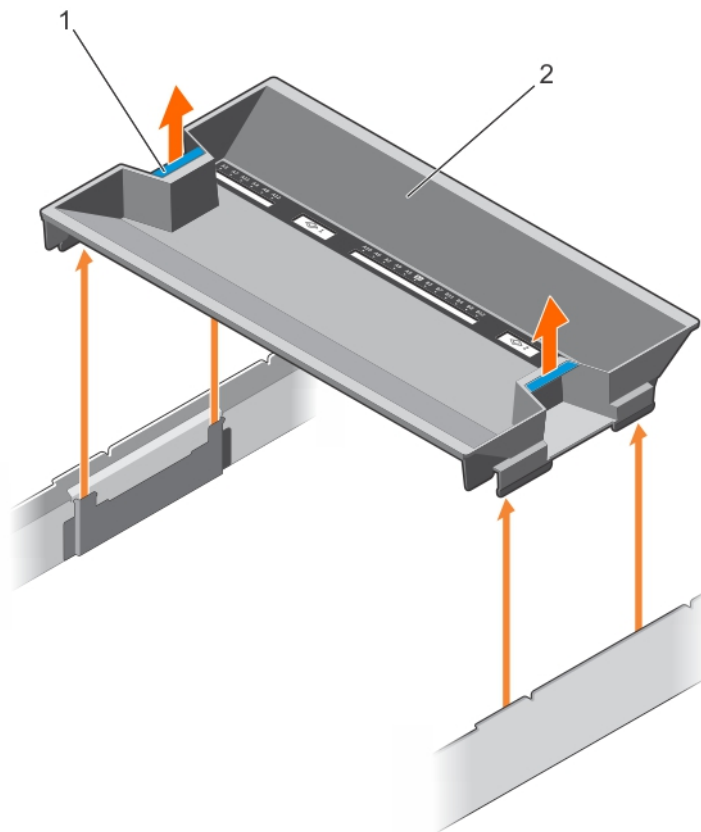

Figure 23. Removing the cooling shroud

- | | |
|----------------------------|---|
| 1. slot on the chassis (4) | 2. touch point (2) |
| 3. cooling shroud | 4. guide slot on the cooling shroud (4) |

Next steps

1. Install the cooling shroud.
2. If required, install the full-length PCIe card.
3. Follow the procedure listed in the After working inside your system section.

Related references

[Safety instructions](#) on page 63

Related tasks

[Before working inside your system](#) on page 64

[Installing the cooling shroud](#) on page 77

[After working inside your system](#) on page 64

Installing the cooling shroud

Prerequisites

 **CAUTION:** Many repairs may only be done by a certified service technician. You should only perform troubleshooting and simple repairs as authorized in your product documentation, or as directed by the online or telephone service and support team. Damage due to servicing that is not authorized by Dell is not covered by your warranty. Read and follow the safety instructions that are shipped with your product.

1. Follow the safety guidelines listed in the Safety instructions section.
2. Follow the procedure listed in the Before working inside your system section.
3. If applicable, route the cables inside the system along the chassis wall and secure the cables by using the cable-securing bracket.

Steps

1. Align the guide slots on the cooling shroud with the slots on the chassis.
2. Lower the cooling shroud into the chassis until it is firmly seated.

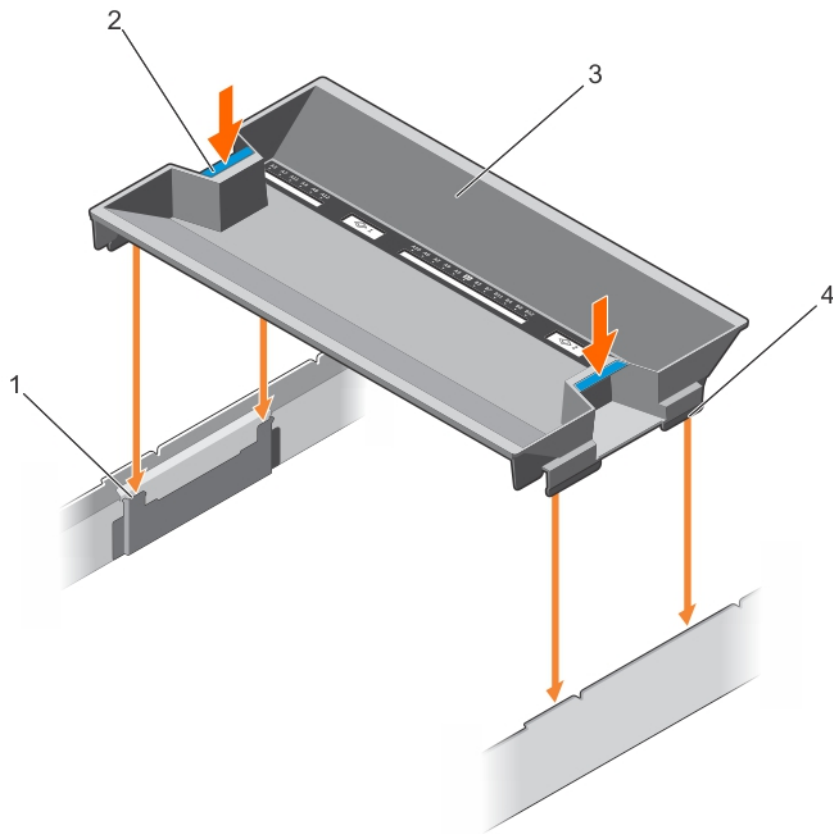

Figure 24. Installing the cooling shroud

- | | |
|----------------------------|---|
| 1. slot on the chassis (4) | 2. touch point (2) |
| 3. cooling shroud | 4. guide slot on the cooling shroud (4) |

Next steps

1. Follow the procedure listed in the After working inside your system section.

Related references

[Safety instructions](#) on page 63

Related tasks

[Before working inside your system](#) on page 64

[After working inside your system](#) on page 64

Cooling fans

Your system supports six hot-swappable cooling fans.

NOTE: In the event of a problem with a particular fan, the fan number is referenced by the system management software, allowing you to easily identify and replace the proper fan by noting the fan numbers on the cooling fan assembly.

Removing a cooling fan

Prerequisites

1. Follow the safety guidelines listed in the Safety instructions section.
2. Follow the procedure listed in the Before working inside your system section.

CAUTION: Many repairs may only be done by a certified service technician. You should only perform troubleshooting and simple repairs as authorized in your product documentation, or as directed by the online or telephone service and support team. Damage due to servicing that is not authorized by Dell is not covered by your warranty. Read and follow the safety instructions that are shipped with your product.

CAUTION: The cooling fans are hot-swappable. To maintain proper cooling while the system is on, replace only one fan at a time.

CAUTION: Do not operate the system with the cover removed or the cooling fan removed, for a duration exceeding five minutes.

NOTE: The procedure for removing each fan is identical.

Steps

Press the fan release tab, and lift the cooling fan out of the cooling fan assembly.

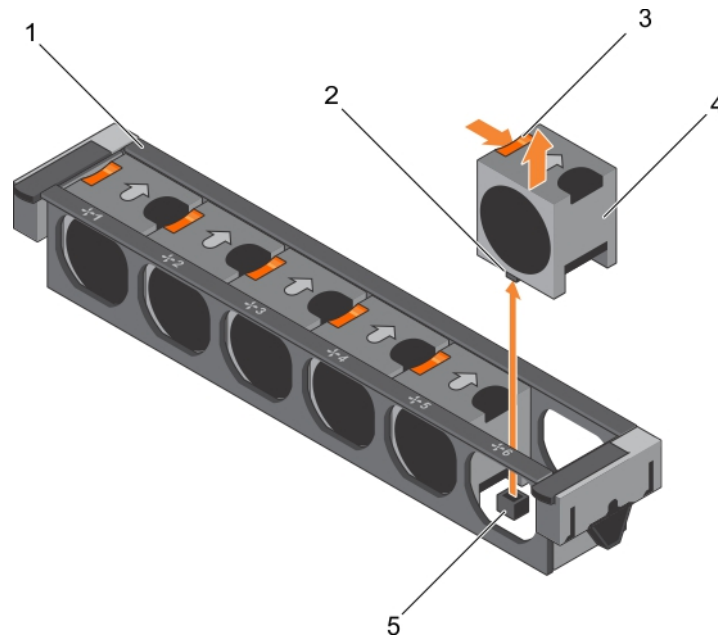

Figure 25. Removing a cooling fan

- | | |
|--|------------------------------|
| 1. cooling fan assembly | 2. cooling fan connector (6) |
| 3. fan release tab (6) | 4. cooling fan (6) |
| 5. cooling fan connector on system board (6) | |

Next steps

1. Replace the cooling fan.
2. Follow the procedure listed in the After working inside your system section.

Related references

[Safety instructions](#) on page 63

Related tasks

[Before working inside your system](#) on page 64

[Installing a cooling fan](#) on page 80

[After working inside your system](#) on page 64

Installing a cooling fan

Prerequisites

1. Follow the safety guidelines listed in the Safety instructions section.
2. Follow the procedure listed in the Before working inside your system section.

 **NOTE:** The procedure for installing each fan is identical.

Steps

1. Align the connector at the base of the cooling fan with the connector on the system board.
2. Slide the cooling fan into the securing slot until the tab locks into place.

Next steps

Follow the procedure listed in the After working inside your system section.

Related references

[Safety instructions](#) on page 63

Related tasks

[Before working inside your system](#) on page 64

[After working inside your system](#) on page 64

Cooling fan assembly

The cooling fan assembly ensures that the key components of the server such as the processors, hard drives, and memory get adequate air circulation to keep them cool. A failure in the server's cooling system can result in the server overheating and may lead to damage.

Removing the cooling fan assembly

Prerequisites

1. Follow the safety guidelines listed in the Safety instructions section.
2. Follow the procedure listed in the Before working inside your system section.

 **CAUTION:** Many repairs may only be done by a certified service technician. You should only perform troubleshooting and simple repairs as authorized in your product documentation, or as directed by the online or telephone service and support team. Damage due to servicing that is not authorized by Dell is not covered by your warranty. Read and follow the safety instructions that are shipped with your product.

Steps

1. Unlock the cooling fan assembly from the chassis by lifting the release levers.
2. Lift the cooling fan assembly out of the chassis.

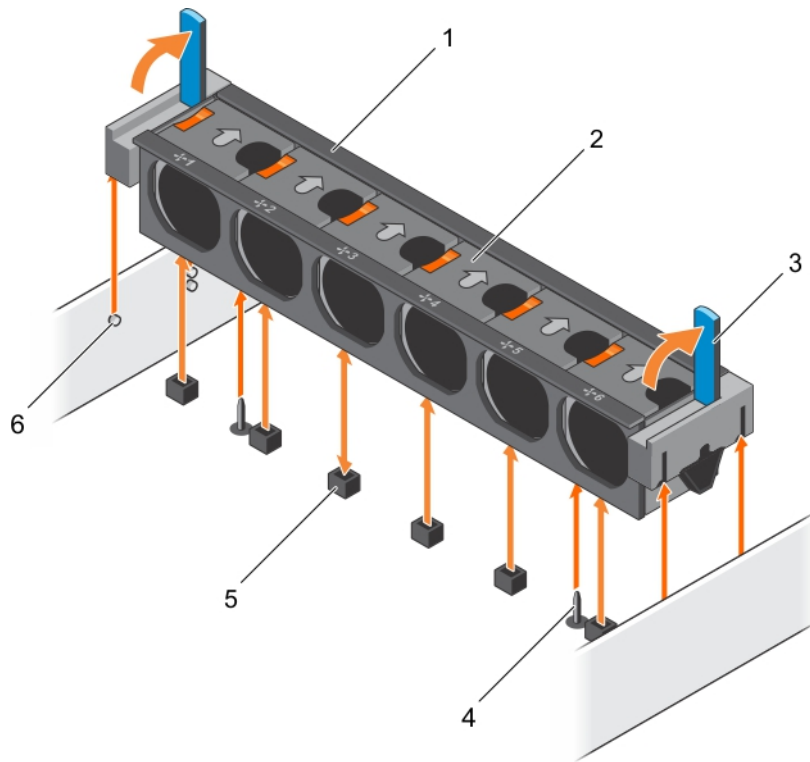

Figure 26. Removing the cooling fan assembly

- | | |
|------------------------------|--------------------------------------|
| 1. cooling fan assembly | 2. cooling fan (6) |
| 3. release lever (2) | 4. guide pin on the system board (2) |
| 5. cooling fan connector (6) | 6. guide pin on the chassis (6) |

Next steps

1. Install the cooling fan assembly.
2. Follow the procedure listed in the After working inside your system section.

Related references

[Safety instructions](#) on page 63

Related tasks

[Before working inside your system](#) on page 64

[Installing the cooling fan assembly](#) on page 81

[After working inside your system](#) on page 64

Installing the cooling fan assembly

Prerequisites

CAUTION: Many repairs may only be done by a certified service technician. You should only perform troubleshooting and simple repairs as authorized in your product documentation, or as directed by the online or telephone service and support team. Damage due to servicing that is not authorized by Dell is not covered by your warranty. Read and follow the safety instructions that are shipped with your product.

1. Follow the safety guidelines listed in Safety instructions section.
2. Follow the procedure listed in the Before working inside your system section.

CAUTION: Ensure that the cables are correctly installed and retained by the cable retention bracket before installing the cooling fan assembly. Incorrectly installed cables may get damaged.

Steps

1. Align the slots on the cooling fan assembly with the guide pins on the chassis.
2. Slide the cooling fan assembly into the chassis.
3. Lock the cooling fan assembly into the chassis by lowering the release levers until firmly seated.

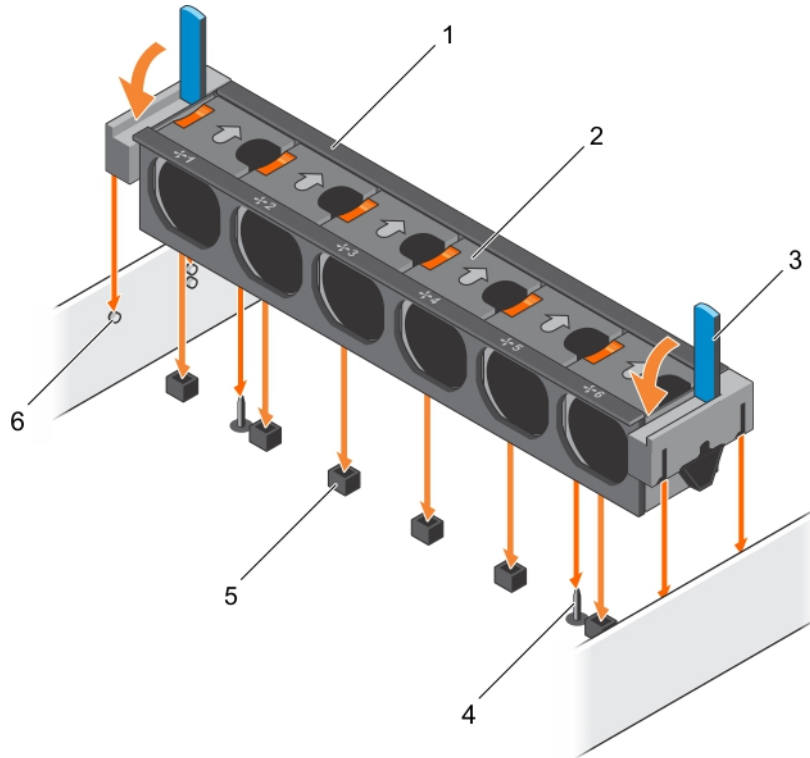

Figure 27. Installing the cooling fan assembly

- | | |
|------------------------------|--------------------------------------|
| 1. cooling fan assembly | 2. cooling fan (6) |
| 3. release lever (2) | 4. guide pin on the system board (2) |
| 5. cooling fan connector (6) | 6. guide pin on the chassis (6) |

Next steps

Follow the procedure listed in the After working inside your system section.

Related references

[Safety instructions](#) on page 63

Related tasks

[Before working inside your system](#) on page 64

[After working inside your system](#) on page 64

System memory

The system supports DDR4 registered DIMMs (RDIMMs) and load reduced DIMMs (LRDIMMs). System memory holds the instructions that are executed by the processor.

NOTE: MT/s indicates DIMM speed in MegaTransfers per second.

Memory bus operating frequency can be 1866 MT/s, 2133 MT/s, or 2400 MT/s depending on the following factors:

- DIMM type (RDIMM or LRDIMM)
- Number of DIMMs populated per channel
- System profile selected (for example, Performance Optimized, Custom, or Dense Configuration Optimized)
- Maximum supported DIMM frequency of the processors

Your system contains 24 memory sockets split into two sets of 12 sockets, one set per processor. Each 12-socket set is organized into four channels. In each channel, the release tabs of the first socket are marked white, the second socket black, and the third socket green.

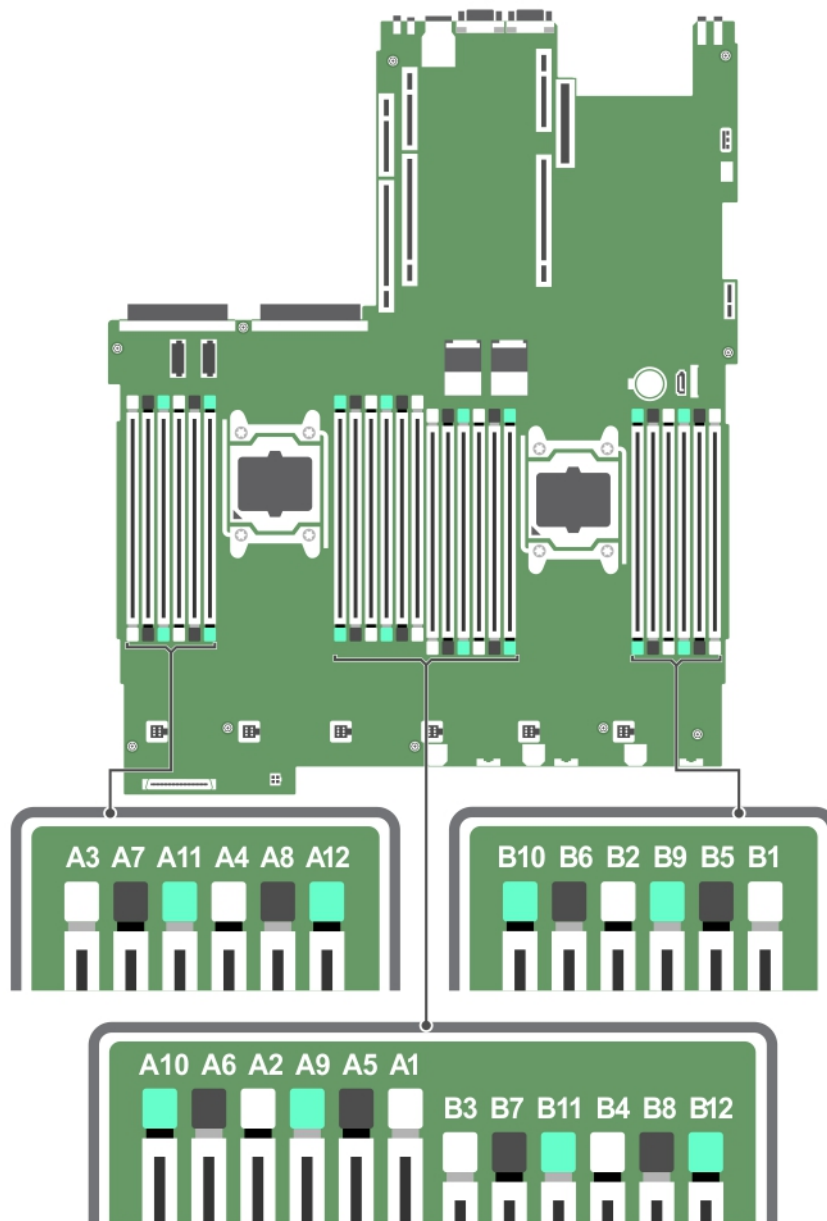

Figure 28. Memory socket locations

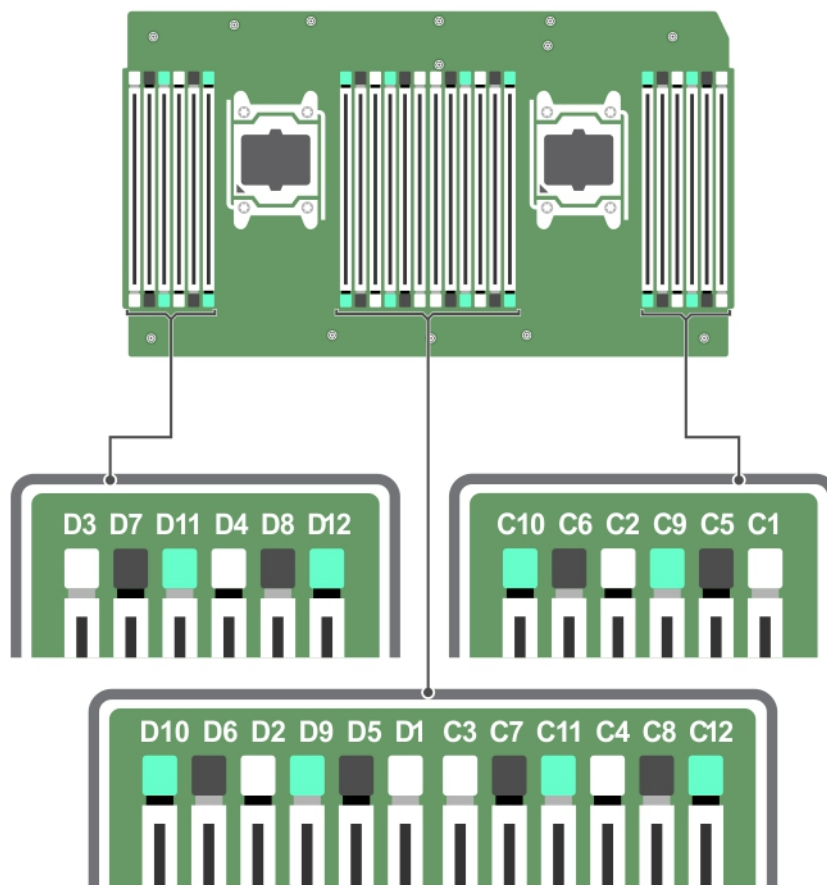

Figure 29. Memory socket locations on the processor expansion module

Memory channels are organized as follows:

Table 28. Memory channels

Processor	Channel 0	Channel 1	Channel 2	Channel 3
Processor 1	Slots A1, A5, and A9	Slots A2, A6, and A10	Slots A3, A7, and A11	Slots A4, A8, and A12
Processor 2	Slots B1, B5, and B9	Slots B2, B6, and B10	Slots B3, B7, and B11	Slots B4, B8, and B12
Processor 3	Slots C1, C5, and C9	Slots C2, C6, and C10	Slots C3, C7, and C11	Slots C4, C8, and C12
Processor 4	Slots D1, D5, and D9	Slots D2, D6, and D10	Slots D3, D7, and D11	Slots D4, D8, and D12

The following table shows the memory populations and operating frequencies for the supported configurations:

Table 29. Memory population

DIMM Type	DIMMs Populated/ Channel	Voltage	Operating Frequency (in MT/s)	Maximum DIMM Rank/ Channel
RDIMM	1	1.2 V	2400, 2133, 1866	Dual rank or single rank
	2		2400, 2133, 1866	Dual rank or single rank
	3		1866	Dual rank or single rank

Table 29. Memory population (continued)

DIMM Type	DIMMs Populated/ Channel	Voltage	Operating Frequency (in MT/s)	Maximum DIMM Rank/ Channel
LRDIMM	1	1.2 V	2400, 2133, 1866	Quad rank
	2		2400, 2133, 1866	Quad rank
	3		2133, 1866	Quad rank

General memory module installation guidelines

NOTE: Memory configurations that fail to observe these guidelines can prevent your system from booting, stop responding during memory configuration, or operating with reduced memory.

The system supports Flexible Memory Configuration, enabling the system to be configured and run in any valid chipset architectural configuration. The following are the recommended guidelines for installing memory modules:

- RDIMMs and LRDIMMs must not be mixed.
- x4 and x8 DRAM based memory modules can be mixed. For more information, see the Mode-specific guidelines section.
- Up to three dual- or single-rank RDIMMs can be populated per channel.
- Up to three LRDIMMs can be populated per channel regardless of rank count.
- If memory modules with different speeds are installed, they will operate at the speed of the slowest installed memory module(s) or slower depending on system DIMM configuration.
- Populate memory module sockets only if a processor is installed. For single-processor systems, sockets A1 to A12 are available. For dual-processor systems, sockets A1 to A12 and sockets B1 to B12 are available.
- Populate all the sockets with white release tabs first, followed by the black release tabs, and then the green release tabs.
- When mixing memory modules with different capacities, populate the sockets with memory modules with highest capacity first. For example, if you want to mix 4 GB and 8 GB memory modules, populate 8 GB memory modules in the sockets with white release tabs and 4 GB memory modules in the sockets with black release tabs.
- In a dual-processor configuration, the memory configuration for each processor should be identical. For example, if you populate socket A1 for processor 1, then populate socket B1 for processor 2, and so on.
- Memory modules of different capacities can be mixed provided other memory population rules are followed (for example, 4 GB and 8 GB memory modules can be mixed).
- Mixing of more than two memory module capacities in a system is not supported.
- Populate four memory modules per processor (one DIMM per channel) at a time to maximize performance.

Related references

[Mode-specific guidelines](#) on page 85

Mode-specific guidelines

Four memory channels are allocated to each processor. The allowable configurations depend on the memory mode selected.

Advanced Error Correction Code

Advanced Error Correction Code (ECC) mode extends SDDC from x4 DRAM based DIMMs to both x4 and x8 DRAMs. This protects against single DRAM chip failures during normal operation.

The installation guidelines for memory modules are as follows:

- Memory modules must be identical in size, speed, and technology.
- DIMMs installed in memory sockets with white release levers must be identical and the same rule applies for sockets with black release levers. This ensures that identical DIMMs are installed in matched pair —for example, A1 with A2, A3 with A4, A5 with A6, and so on.

Memory optimized independent channel mode

This mode supports Single Device Data Correction (SDDC) only for memory modules that use x4 device width. It does not impose any specific slot population requirements.

Memory sparing

NOTE: To use memory sparing, this feature must be enabled in System Setup.

In this mode, one rank per channel is reserved as a spare. If persistent correctable errors are detected on a rank, the data from this rank is copied to the spare rank, and the failed rank is disabled.

With memory sparing enabled, the system memory available to the operating system is reduced by one rank per channel. For example, in a dual-processor configuration with sixteen 4 GB single-rank memory modules, the available system memory is: 3/4 (ranks/channel) × 16 (memory modules) × 4 GB = 48 GB, and not 16 (memory modules) × 4 GB = 64 GB.

NOTE: Memory sparing does not offer protection against a multi-bit uncorrectable error.

NOTE: Both Advanced ECC/Lockstep and Optimizer modes support memory sparing.

Memory mirroring

Memory mirroring offers the strongest memory module reliability mode compared to all other modes, providing improved uncorrectable multi-bit failure protection. In a mirrored configuration, the total available system memory is one half of the total installed physical memory. Half of the installed memory is used to mirror the active memory modules. In the event of an uncorrectable error, the system switches over to the mirrored copy. This ensures SDDC and multi-bit protection.

The installation guidelines for memory modules are as follows:

- Memory modules must be identical in size, speed, and technology.
- Memory modules installed in memory module sockets with white release levers must be identical and the same rule applies for sockets with black and green release tabs. This ensures that identical memory modules are installed in matched pairs—for example, A1 with A2, A3 with A4, A5 with A6, and so on.

Table 30. Processor configuration

Processor	Configuration	Memory population rules	Memory population information
Single CPU	Memory population order	{1,2}, {3,4}	See Memory mirroring note

Sample memory configurations

The following tables show sample memory configurations for two and four processor configurations that follow the appropriate memory guidelines.

NOTE: 1R, 2R, 4R, and 8R in the following tables indicate single, dual, quad, and octal rank DIMMs.

Table 31. Memory configurations – two processors

System Capacity (in GB)	DIMM Size (in GB)	Number of DIMMs	DIMM rank, organization, and frequency	DIMM Slot Population
16	8	2	1R x8, 1866 MT/s	A1, B1
			1R x8, 2133 MT/s	
			1R x8, 2400 MT/s	
32	8	4	1R x8, 1866 MT/s	A1, A2, B1, B2
			1R x8, 2133 MT/s	
			1R x8, 2400 MT/s	

Table 31. Memory configurations – two processors (continued)

System Capacity (in GB)	DIMM Size (in GB)	Number of DIMMs	DIMM rank, organization, and frequency	DIMM Slot Population
64	8	8	1R x8, 1866 MT/s 1R x8, 2133 MT/s 1R x8, 2400 MT/s	A1, A2, A3, A4, B1, B2, B3, B4
128	8	16	1R x8, 1866 MT/s 1R x8, 2133 MT/s 1R x8, 2400 MT/s	A1, A2, A3, A4, A5, A6, A7, A8, B1, B2, B3, B4, B5, B6, B7, B8
32	8	8	1R x8, 1866 MT/s 1R x8, 2133 MT/s 1R x8, 2400 MT/s	A1, A2, A3, A4, B1, B2, B3, B4
64	8	16	1R x8, 1866 MT/s 1R x8, 2133 MT/s 1R x8, 2400 MT/s	A1, A2, A3, A4, A5, A6, A7, A8, B1, B2, B3, B4, B5, B6, B7, B8
64	8	8	1R x8, 1866 MT/s 1R x8, 2133 MT/s 1R x8, 2400 MT/s	A1, A2, A3, A4, B1, B2, B3, B4
96	8	24	1R x8, 1600 MT/s 1R x8, 1866 MT/s	A1, A2, A3, A4, A5, A6, A7, A8, A9, A10, A11, A12, B1, B2, B3, B4, B5, B6, B7, B8, B9, B10, B11, B12
96	8	12	1R x8, 1866 MT/s 1R x8, 2133 MT/s 1R x8, 2400 MT/s	A1, A2, A3, A4, A5, A6, B1, B2, B3, B4, B5, B6
128	8	16	1R x8, 1866 MT/s 1R x8, 2133 MT/s 1R x8, 2400 MT/s	A1, A2, A3, A4, A5, A6, A7, A8, B1, B2, B3, B4, B5, B6, B7, B8
128	16	8	2R x8, 1866 MT/s 2R x8, 2133 MT/s 2R x8, 2400 MT/s	A1, A2, A3, A4, B1, B2, B3, B4
160	8	20	1R x4, 1866 MT/s	A1, A2, A3, A4, A5, A6, A7, A8, A9, A11, B1, B2, B3, B4, B5, B6, B7, B8, B9, B11
160	16 and 8	12	1R x8, 1866 MT/s 1R x8, 2133 MT/s 1R x8, 2400 MT/s	A1, A2, A3, A4, A5, A6, B1, B2, B3, B4, B5, B6

NOTE: 16 GB DIMMs must be installed in the slots numbered A1, A2, A3, A4, B1, B2, B3, and B4 and 8 GB DIMMs must be installed in slots A5, A6, B5 and B6.

Table 31. Memory configurations – two processors (continued)

System Capacity (in GB)	DIMM Size (in GB)	Number of DIMMs	DIMM rank, organization, and frequency	DIMM Slot Population
192	8	24	1R x4, 1866 MT/s	A1, A2, A3, A4, A5, A6, A7, A8, A9, A10, A11, A12, B1, B2, B3, B4, B5, B6, B7, B8, B9, B10, B11, B12
192	16	12	2R x8, 1866 MT/s 2R x8, 2133 MT/s 2R x8, 2400 MT/s	A1, A2, A3, A4, A5, A6, B1, B2, B3, B4, B5, B6
256	16	16	2R x8, 1866 MT/s 2R x8, 2133 MT/s 2R x8, 2400 MT/s	A1, A2, A3, A4, A5, A6, A7, A8, B1, B2, B3, B4, B5, B6, B7, B8
	128	2	8R x4, 2400 MT/s	A1, B1
384	16	24	2R x8, 1866 MT/s	A1, A2, A3, A4, A5, A6, A7, A8, A9, A10, A11, A12, B1, B2, B3, B4, B5, B6, B7, B8, B9, B10, B11, B12
512	32	16	2R x4, 1866 MT/s 2R x4, 2133 MT/s 2R x4, 2400 MT/s	A1, A2, A3, A4, A5, A6, A7, A8, B1, B2, B3, B4, B5, B6, B7, B8
	64	8	4R x4, 2400 MT/s 4R x4, 2133 MT/s	A1, A2, A3, A4, B1, B2, B3, B4
	128	4	4R x4, 2400 MT/s	A1, A2, B1, B2
768	32	24	2R x4, 1866 MT/s	A1, A2, A3, A4, A5, A6, A7, A8, A9, A10, A11, A12, B1, B2, B3, B4, B5, B6, B7, B8, B9, B10, B11, B12
	64	12	4R x4, 2400 MT/s 4R x4, 2133 MT/s	A1, A2, A3, A4, A5, A6, B1, B2, B3, B4, B5, B6
1024	64	16	4R x4, 2133 MT/s	A1, A2, A3, A4, A5, A6, A7, A8, B1, B2, B3, B4, B5, B6, B7, B8
	128	8	4R x4, 2400 MT/s	A1, A2, A3, A4, B1, B2, B3, B4
1536	64	24	4R x4, 1866 MT/s 4R x4, 2133 MT/s	A1, A2, A3, A4, A5, A6, A7, A8, A9, A10, A11, A12, B1, B2, B3, B4, B5, B6, B7, B8, B9, B10, B11, B12
	128	12	4R x4, 2400 MT/s	A1, A2, A3, A4, A5, A6, B1, B2, B3, B4, B5, B6
2048	128	16	4R x4, 2400 MT/s	A1, A2, A3, A4, A5, A6, A7, A8, B1, B2, B3, B4, B5, B6, B7, B8
2560	128	20	4R x4, 2133 MT/s 4R x4, 1866 MT/s	A1, A2, A3, A4, A5, A6, A7, A8, A9, A10, B1, B2, B3, B4, B5, B6, B7, B8, B9, B10

Table 31. Memory configurations – two processors (continued)

System Capacity (in GB)	DIMM Size (in GB)	Number of DIMMs	DIMM rank, organization, and frequency	DIMM Slot Population
3072	128	24	4R x4, 2133 MT/s 4R x4, 1866 MT/s	A1, A2, A3, A4, A5, A6, A7, A8, A9, A10, A11, A12, B1, B2, B3, B4, B5, B6, B7, B8, B9, B10, B11, B12

Table 32. Memory configurations – four processor

System Capacity (in GB)	DIMM Size (in GB)	Number of DIMMs	Organization and Speed	DIMM Slot Population
32	8	4	1R x8, 1866 MT/s 1R x8, 2133 MT/s 1R x8, 2400 MT/s	A1, B1, C1, D1
64	8	8	1R x8, 1866 MT/s 1R x8, 2133 MT/s 1R x8, 2400 MT/s	A1, A2, B1, B2, C1, C2, D1, D2
32	8	16	1R x8, 1866 MT/s 1R x8, 2133 MT/s 1R x8, 2400 MT/s	A1, A2, A3, A4, B1, B2, B3, B4, C1, C2, C3, C4, D1, D2, D3, D4
64	8	32	1R x8, 1866 MT/s 1R x8, 2133 MT/s 1R x8, 2400 MT/s	A1, A2, A3, A4, A5, A6, A7, A8, B1, B2, B3, B4, B5, B6, B7, B8, C1, C2, C3, C4, C5, C6, C7, C8, D1, D2, D3, D4, D5, D6, D7, D8
96	8	48	1R x8, 1866 MT/s	A1, A2, A3, A4, A5, A6, A7, A8, A9, A10, A11, A12, B1, B2, B3, B4, B5, B6, B7, B8, B9, B10, B11, B12, C1, C2, C3, C4, C5, C6, C7, C8, C9, C10, C11, C12, D1, D2, D3, D4, D5, D6, D7, D8, D9, D10, D11, D12
64	8	16	1R x8, 1866 MT/s 1R x8, 2133 MT/s 1R x8, 2400 MT/s	A1, A2, A3, A4, B1, B2, B3, B4, C1, C2, C3, C4, D1, D2, D3, D4
96	8	24	1R x8, 1866 MT/s 1R x8, 2133 MT/s 1R x8, 2400 MT/s	A1, A2, A3, A4, A5, A6, B1, B2, B3, B4, B5, B6, C1, C2, C3, C4, C5, C6, D1, D2, D3, D4, D5, D6
128	8	32	1R x8, 1866 MT/s 1R x8, 2133 MT/s 1R x8, 2400 MT/s	A1, A2, A3, A4, A5, A6, A7, A8, B1, B2, B3, B4, B5, B6, B7, B8, C1, C2, C3, C4, C5, C6, C7, C8, D1, D2, D3, D4, D5, D6, D7, D8
128	8	16	1R x8, 1866 MT/s 1R x8, 2133 MT/s 1R x8, 2400 MT/s	A1, A2, A3, A4, B1, B2, B3, B4, C1, C2, C3, C4, D1, D2, D3, D4
192	8	48	1R x8, 1866 MT/s	A1, A2, A3, A4, A5, A6, A7, A8, A9, A10, A11, A12, B1, B2, B3, B4,

Table 32. Memory configurations – four processor (continued)

System Capacity (in GB)	DIMM Size (in GB)	Number of DIMMs	Organization and Speed	DIMM Slot Population
				B5, B6, B7, B8, B9, B10, B11, B12, C1, C2, C3, C4, C5, C6, C7, C8, C9, C10, C11, C12, D1, D2, D3, D4, D5, D6, D7, D8, D9, D10, D11, D12
192	8	24	1R x8, 1866 MT/s 1R x8, 2133 MT/s 1R x8, 2400 MT/s	A1, A2, A3, A4, A5, A6, B1, B2, B3, B4, B5, B6, C1, C2, C3, C4, C5, C6, D1, D2, D3, D4, D5, D6
256	16	16	2R x8, 1866 MT/s 2R x8, 2133 MT/s 2R x8, 2400 MT/s	A1, A2, A3, A4, B1, B2, B3, B4, C1, C2, C3, C4, D1, D2, D3, D4
384	16	24	1R x8, 1866 MT/s 1R x8, 2133 MT/s 1R x8, 2400 MT/s	A1, A2, A3, A4, A5, A6, B1, B2, B3, B4, B5, B6, C1, C2, C3, C4, C5, C6, D1, D2, D3, D4, D5, D6
512	32	16	2R x4, 1866 MT/s 2R x4, 2133 MT/s 2R x4, 2400 MT/s	A1, A2, A3, A4, B1, B2, B3, B4, C1, C2, C3, C4, D1, D2, D3, D4
768	32	24	2R x4, 1866 MT/s 2R x4, 2133 MT/s 2R x4, 2400 MT/s	A1, A2, A3, A4, A5, A6, B1, B2, B3, B4, B5, B6, C1, C2, C3, C4, C5, C6, D1, D2, D3, D4, D5, D6
1024	32	32	2R x4, 1866 MT/s 2R x4, 2133 MT/s 2R x4, 2400 MT/s	A1, A2, A3, A4, A5, A6, A7, A8, B1, B2, B3, B4, B5, B6, B7, B8, C1, C2, C3, C4, C5, C6, C7, C8, D1, D2, D3, D4, D5, D6, D7, D8
1536	32	48	4R x4, 1866 MT/s	A1, A2, A3, A4, A5, A6, A7, A8, A9, A10, A11, A12, B1, B2, B3, B4, B5, B6, B7, B8, B9, B10, B11, B12, C1, C2, C3, C4, C5, C6, C7, C8, C9, C10, C11, C12, D1, D2, D3, D4, D5, D6, D7, D8, D9, D10, D11, D12
64 G LRDIMM				
2048	64	32	4R x4, 1866 MT/s 4R x4, 2133 MT/s 4R x4, 2400 MT/s	A1, A2, A3, A4, A5, A6, A7, A8, B1, B2, B3, B4, B5, B6, B7, B8, C1, C2, C3, C4, C5, C6, C7, C8, D1, D2, D3, D4, D5, D6, D7, D8
3072	64	48	4R x4, 2133 MT/s 4R x4, 1866 MT/s	A1, A2, A3, A4, A5, A6, A7, A8, A9, A10, A11, A12, B1, B2, B3, B4, B5, B6, B7, B8, B9, B10, B11, B12, C1, C2, C3, C4, C5, C6, C7, C8, C9, C10, C11, C12, D1, D2, D3, D4, D5, D6, D7, D8, D9, D10, D11, D12
128 G LRDIMM				

Table 32. Memory configurations – four processor (continued)

System Capacity (in GB)	DIMM Size (in GB)	Number of DIMMs	Organization and Speed	DIMM Slot Population
4096	128	32	4R x4, 1866 MT/s 4R x4, 2133 MT/s 4R x4, 2400 MT/s	A1, A2, A3, A4, A5, A6, A7, A8, B1, B2, B3, B4, B5, B6, B7, B8, C1, C2, C3, C4, C5, C6, C7, C8, D1, D2, D3, D4, D5, D6, D7, D8
6144	128	48	4R x4, 2133 MT/s 4R x4, 1866 MT/s	A1, A2, A3, A4, A5, A6, A7, A8, A9, A10, A11, A12, B1, B2, B3, B4, B5, B6, B7, B8, B9, B10, B11, B12, C1, C2, C3, C4, C5, C6, C7, C8, C9, C10, C11, C12, D1, D2, D3, D4, D5, D6, D7, D8, D9, D10, D11, D12

Removing memory modules

Prerequisites

CAUTION: Many repairs may only be done by a certified service technician. You should only perform troubleshooting and simple repairs as authorized in your product documentation, or as directed by the online or telephone service and support team. Damage due to servicing that is not authorized by Dell is not covered by your warranty. Read and follow the safety instructions that are shipped with your product.

1. Follow the safety guidelines listed in the Safety instructions section.
2. Follow the procedure listed in the Before working inside your system section.
3. Remove the cooling shroud.

NOTE: The memory modules are hot to touch for some time after the system has been powered down. Allow the memory modules to cool before handling them. Handle the memory modules by the card edges and avoid touching the components or metallic contacts on the memory module.

CAUTION: To ensure proper system cooling, memory module blanks must be installed in any memory socket that is not occupied. Remove memory module blanks only if you intend to install memory modules in those sockets.

Steps

1. Locate the appropriate memory module socket.

CAUTION: Handle each memory module only by the card edges, ensuring not to touch the middle of the memory module or metallic contacts.

2. To release the memory module from the socket, simultaneously press the ejectors on both ends of the memory module socket.
3. Lift and remove the memory module from the system.

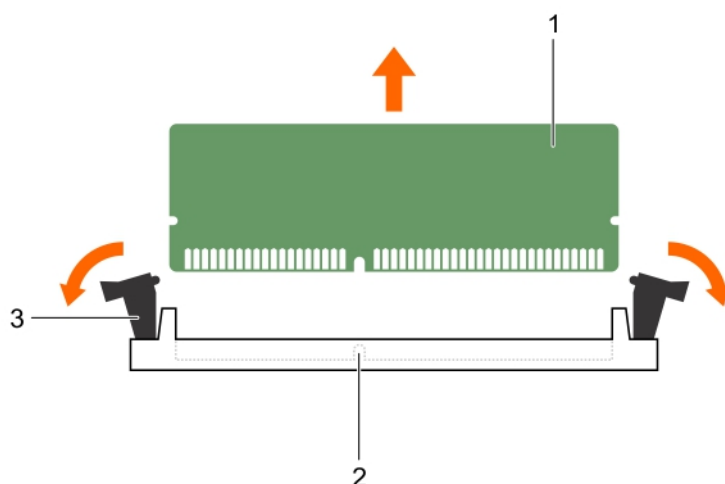

Figure 30. Removing the memory module

- a. memory module
- b. memory module socket
- c. memory module socket ejector (2)

Next steps

1. Install the memory module.
 - NOTE:** If you are removing the memory module permanently, install a memory module blank.
2. Install the cooling shroud.
3. Follow the procedure listed in the After working inside your system section.

Related references

[Safety instructions](#) on page 63

Related tasks

[Before working inside your system](#) on page 64

[Removing the cooling shroud](#) on page 76

[Installing memory modules](#) on page 92

[After working inside your system](#) on page 64

Installing memory modules

Prerequisites

NOTE: The memory modules are hot to touch for some time after the system has been powered down. Allow the memory modules to cool before handling them. Handle the memory modules by the card edges and avoid touching the components or metallic contacts on the memory module.

CAUTION: Many repairs may only be done by a certified service technician. You should only perform troubleshooting and simple repairs as authorized in your product documentation, or as directed by the online or telephone service and support team. Damage due to servicing that is not authorized by Dell is not covered by your warranty. Read and follow the safety instructions that are shipped with your product.

1. Follow the safety guidelines listed in the Safety instructions section.
2. Follow the procedure listed in the Before working inside your system section.

Steps

1. Locate the appropriate memory module socket.

CAUTION: Handle each memory module only by the card edges, ensuring not to touch the middle of the memory module or metallic contacts.

2. Open the ejectors on the memory module socket outward to allow the memory module to be inserted into the socket.
3. Align the edge connector of the memory module with the alignment key of the memory module socket, and insert the memory module in the socket.

CAUTION: Do not apply pressure at the center of the memory module; apply pressure at both ends of the memory module evenly.

NOTE: The memory module socket has an alignment key that enables you to install the memory module in the socket in only one orientation.

4. Press the memory module with your thumbs until the socket levers firmly click into place.

When the memory module is properly seated in the socket, the levers on the memory module socket align with the levers on the other sockets that have memory modules installed.

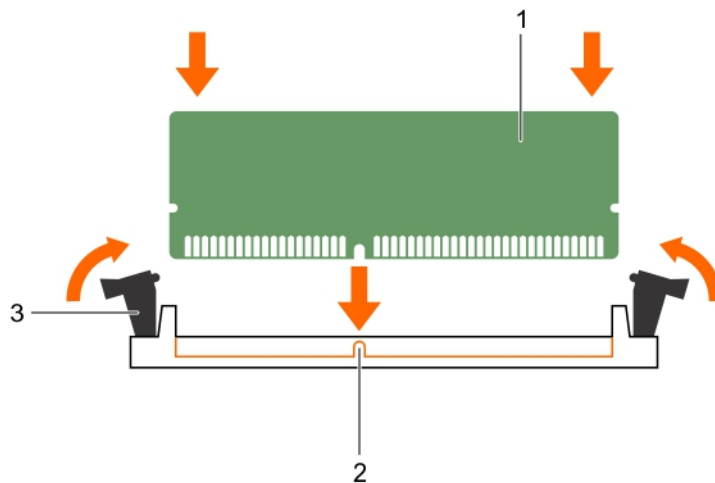

Figure 31. Installing the memory module

- a. memory module
- b. alignment key
- c. memory module socket ejector (2)

Next steps

1. Follow the procedure listed in the After working inside your system section.
2. Press F2 to enter System Setup, and check the **System Memory** setting.
The system should have already changed the value to reflect the installed memory.
3. If the value is incorrect, one or more of the memory modules may not be installed properly. Ensure that the memory module is firmly seated in the memory module socket.
4. Run the system memory test in system diagnostics.

Related references

[Safety instructions](#) on page 63

Related tasks

[Before working inside your system](#) on page 64

[Installing the cooling shroud](#) on page 77

[After working inside your system](#) on page 64

Processors and heat sinks

Use the following procedures when:

- Removing and installing a heat sink
- Installing an additional processor
- Replacing a processor

 **NOTE:** To ensure proper cooling, you must install a processor blank in any empty processor socket.

Removing a heat sink

Prerequisites

 **CAUTION:** Never remove the heat sink from a processor unless you intend to remove the processor. The heat sink is necessary to maintain proper thermal conditions.

 **WARNING:** The heat sink is hot to touch. Allow the heat sink to cool for some time after powering down the system.

1. Follow the safety guidelines listed in the Safety instructions section.
2. Follow the procedure listed in the Before working inside your system section.
3. If installed, remove the full-length PCIe card(s).
4. Remove the cooling shroud.
5. Keep the Phillips #2 screwdriver ready.

Steps

1. Loosen one of the screws that secure the heat sink to the system board.
Allow some time (approximately 30 seconds) for the heat sink to loosen from the processor.
2. Remove the screw diagonally opposite to the screw that you first removed.
3. Repeat step 1 and 2 for removing the remaining two screws.
4. Remove the heat sink.

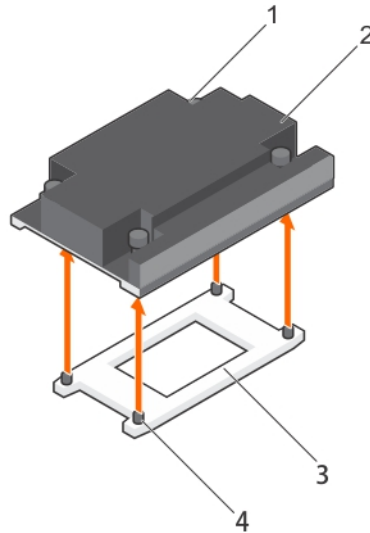

Figure 32. Removing a heat sink

- | | |
|-------------------------|------------------------------|
| 1. retention screws (4) | 2. heat sink |
| 3. processor shield | 4. retention screw slots (4) |

Next steps

1. Replace the heat sink(s) and processor(s).
2. Replace the processor and heat sink.
3. Follow the procedure listed in the After working inside your system section.

Related references

[Safety instructions](#) on page 63

Related tasks

[Before working inside your system](#) on page 64

[Removing the cooling shroud](#) on page 76

[After working inside your system](#) on page 64

Removing a processor

Prerequisites

CAUTION: Many repairs may only be done by a certified service technician. You should only perform troubleshooting and simple repairs as authorized in your product documentation, or as directed by the online or telephone service and support team. Damage due to servicing that is not authorized by Dell is not covered by your warranty. Read and follow the safety instructions that are shipped with your product.

NOTE: This is a Field Replaceable Unit (FRU). Removal and installation procedures should be performed only by Dell certified service technicians.

NOTE: If you are upgrading your system, download the latest system BIOS version from [Dell.com/support](https://www.dell.com/support) and follow the instructions included in the compressed download file to install the update on your system.

NOTE: You can update the system BIOS by using the Dell Lifecycle Controller.

NOTE: To ensure proper system cooling, you must install a processor blank in any empty processor socket.



1. Follow the safety guidelines listed in the Safety instructions section.

2. Follow the procedure listed in the Before working inside your system section.
3. Keep the Phillips #2 screwdriver ready.
4. Remove the cooling shroud.
5. Remove the heat sink.

 **WARNING:** The processor is hot to touch for some time after the system has been powered down. Allow the processor to cool before removing it.

 **CAUTION:** The processor is held in its socket under strong pressure. Be aware that the release lever can spring up suddenly if not firmly grasped.

Steps

1. Release the *open first* socket lever near the unlock icon  by pushing the lever down and out from under the tab.
2. Release the *close first* socket release lever near the lock icon  by pushing the lever down and out from under the tab. Lift the lever 90 degrees upward.
3. Lower the *open first* socket-release lever to lift the processor shield.
4. Hold the tab on the processor shield and lift the processor shield until the *open first* socket-release lever lifts up.

 **CAUTION:** The socket pins are fragile and can be permanently damaged. Be careful not to bend the pins in the socket when removing the processor out of the socket.

5. Lift the processor out of the socket and leave the *open first* socket-release lever up.

 **NOTE:** If you are permanently removing the processor, you must install a socket protective cap in the vacant socket to protect the socket pins and keep the socket free of dust.

 **NOTE:** After removing the processor, place it in an anti-static container for reuse, return, or temporary storage. Do not touch the bottom of the processor. Touch only the side edges of the processor.

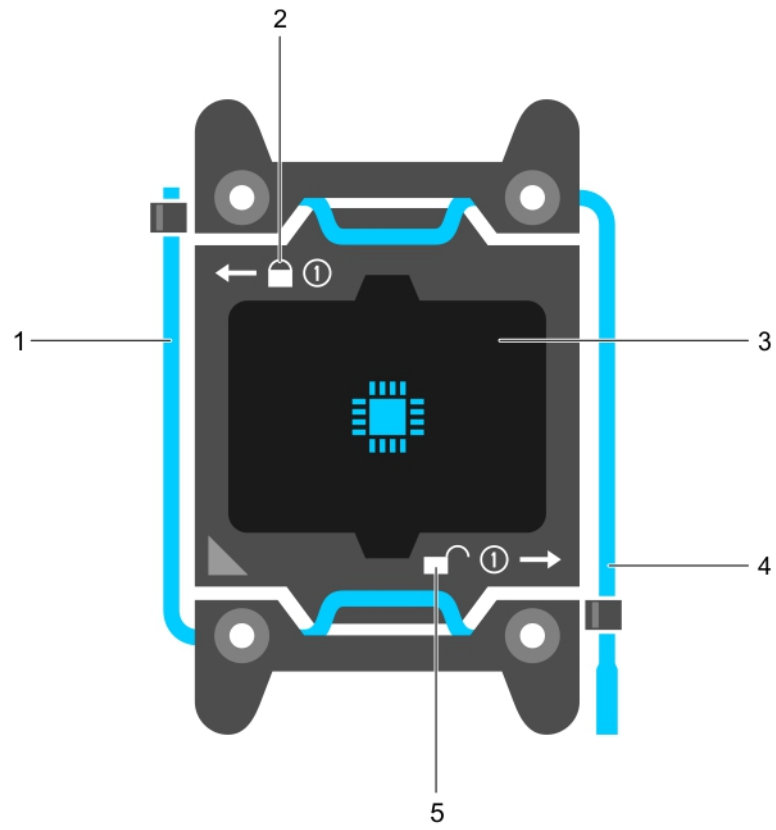

Figure 33. Processor shield

- 1. *close first* socket release lever
- 2. lock icon
- 3. processor
- 4. *open first* socket release lever
- 5. unlock icon

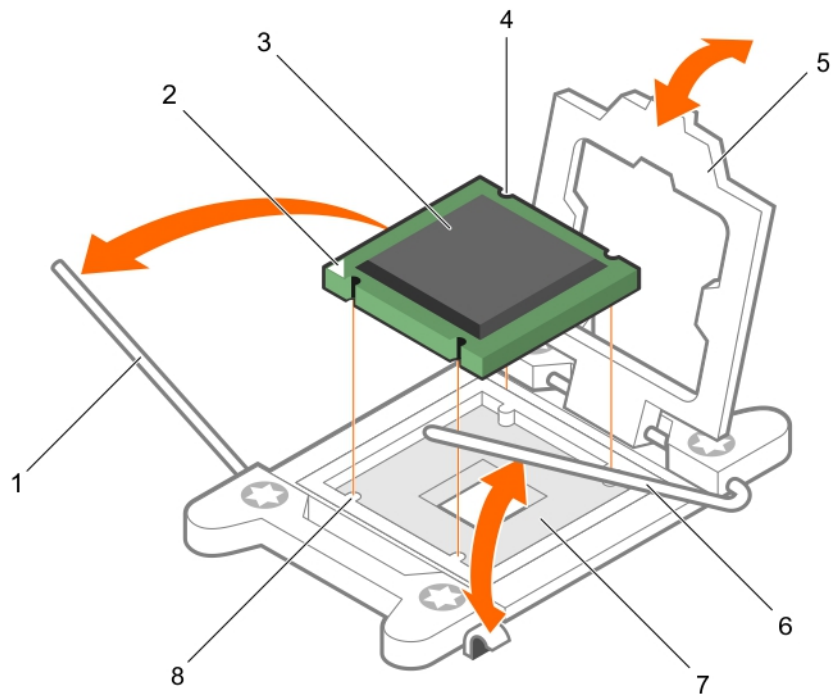

Figure 34. Removing a processor

- | | |
|--|---|
| <ol style="list-style-type: none"> 1. <i>close first</i> socket-release lever 3. processor 5. processor shield 7. socket | <ol style="list-style-type: none"> 2. pin-1 indicator of processor 4. slot (4) 6. <i>open first</i> socket-release lever 8. socket keys (4) |
|--|---|

Next steps

1. Replace the processor(s).
2. Install the heat sink.
3. Reinstall the cooling shroud.
4. Follow the procedure listed in the After working inside your system section.

Related references

[Safety instructions](#) on page 63

Related tasks

- [Before working inside your system](#) on page 64
- [Removing the cooling shroud](#) on page 76
- [Removing a heat sink](#) on page 94
- [Installing a heat sink](#) on page 101
- [Installing the cooling shroud](#) on page 77
- [After working inside your system](#) on page 64

Installing a processor

Prerequisites

CAUTION: Many repairs may only be done by a certified service technician. You should only perform troubleshooting and simple repairs as authorized in your product documentation, or as directed by the online or telephone service and support team. Damage due to servicing that is not authorized by Dell is not covered by your warranty. Read and follow the safety instructions that are shipped with your product.

1. Follow the safety guidelines listed in the Safety instructions section.
2. Follow the procedure listed in the Before working inside your system section.
3. Keep the Phillips #2 screwdriver ready.
4. If you are upgrading your system, download the latest system BIOS version from **Dell.com/support** and follow the instructions included in the compressed download file to install the update on your system.

NOTE: You can also update the system BIOS by using the Dell Lifecycle Controller.

5. Remove the cooling shroud.

NOTE: If applicable, close the expansion card latch on the cooling shroud to release the full length card.

6. If connected, disconnect the cables from expansion card(s).
7. If installed, remove the expansion card riser.

NOTE: The heat sink and processor are too hot to touch for some time after the system has been powered down. Allow the heat sink and processor to cool down before handling them.



CAUTION: Never remove the heat sink from a processor unless you intend to remove the processor. The heat sink is necessary to maintain proper thermal conditions.

NOTE: If you are installing a single processor, it must be installed in socket CPU1.

Steps

1. Unpack the new processor.

NOTE: If the processor has previously been used in a system, remove any remaining thermal grease from the processor by using a lint-free cloth.



2. Locate the processor socket.
3. If applicable, remove the socket protective cap.
4. Release the *open first* socket-release lever near the unlock icon  by pushing the lever down and out from under the tab.
5. Similarly, release the *close first* socket-release lever near the lock icon  by pushing the lever down and out from under the tab. Lift the lever 90 degrees upward.
6. Hold the tab near the lock symbol on the processor shield and lift it up and out of the way.

CAUTION: Positioning the processor incorrectly can permanently damage the system board or the processor. Be careful not to bend the pins in the socket.

CAUTION: While removing or reinstalling the processor, wipe your hands of any contaminants. Contaminants on the processor pins such as thermal grease or oil can damage the processor.

7. Align the processor with the socket keys.

CAUTION: Do not use force to seat the processor. When the processor is positioned correctly, it engages easily into the socket.

8. Align the pin-1 indicator of the processor with the triangle on the system board.
9. Place the processor on the socket such that the slots on the processor align with the socket keys.
10. Close the processor shield.
11. Lower the *close first* socket-release lever near the lock icon  and push it under the tab to lock it.
12. Similarly, lower the *open first* socket-release lever near the unlock icon  and push it under the tab to lock it.

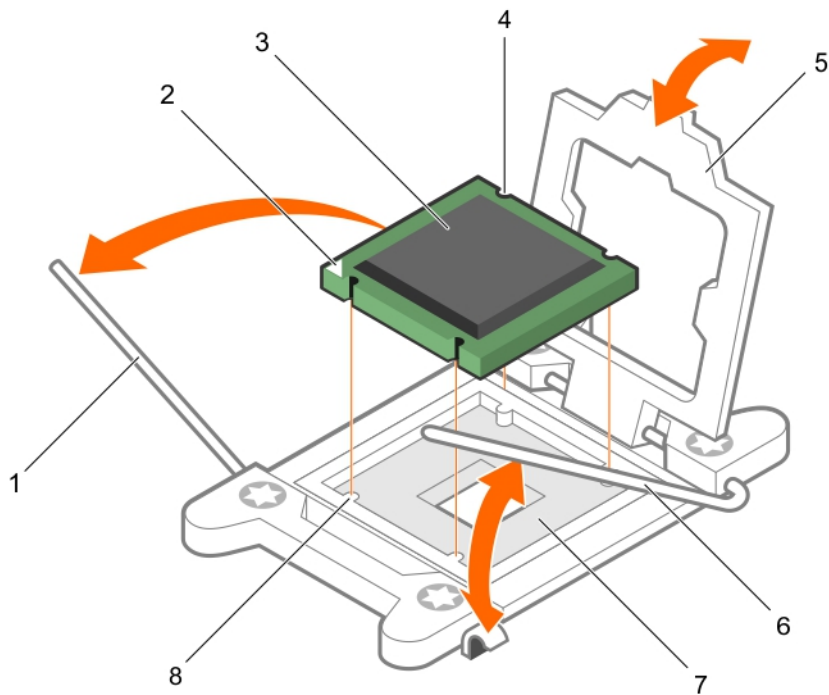

Figure 35. Installing a processor

- | | |
|---------------------------|----------------------------------|
| 1. socket-release lever 1 | 2. pin-1 corner of the processor |
| 3. processor | 4. slot (4) |
| 5. processor shield | 6. socket-release lever 2 |
| 7. processor socket | 8. tab (4) |

Next steps

NOTE: Ensure that you install the heat sink after you install the processor. The heat sink is necessary to maintain proper thermal conditions.

1. Install the heat sink.
2. If removed, reinstall the PCIe expansion card riser.
3. If disconnected, reconnect the cables to the expansion card(s).
4. Follow the procedure listed in the After working inside your system.
5. While booting, press F2 to enter System Setup and verify that the processor information matches the new system configuration.
6. Run the system diagnostics to verify that the new processor operates correctly.

Related references

[Safety instructions](#) on page 63

Related tasks

[Before working inside your system](#) on page 64

[Removing the cooling shroud](#) on page 76

[Removing expansion card risers](#) on page 111

[Installing a heat sink](#) on page 101

[After working inside your system](#) on page 64

Installing a heat sink

Prerequisites

CAUTION: Many repairs may only be done by a certified service technician. You should only perform troubleshooting and simple repairs as authorized in your product documentation, or as directed by the online or telephone service and support team. Damage due to servicing that is not authorized by Dell is not covered by your warranty. Read and follow the safety instructions that are shipped with your product.

1. Follow the safety guidelines listed in the Safety instructions section.
2. Follow the procedure listed in the Before working inside your system section.
3. Install the processor.
4. Keep the Phillips #2 screwdriver ready.

Steps

1. If you are using an existing heat sink, remove the thermal grease from the heat sink by using a clean lint-free cloth.
2. Use the thermal grease syringe included with your processor kit to apply the grease in a thin spiral on the top of the processor.

CAUTION: Applying too much thermal grease can result in excess grease coming in contact with and contaminating the processor socket.

NOTE: The thermal grease syringe is intended for one-time use only. Dispose of the syringe after you use it.

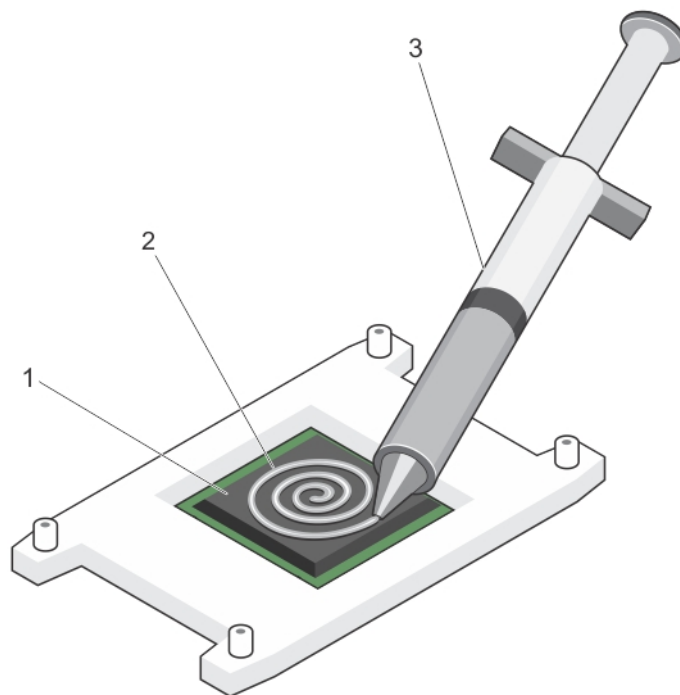

Figure 36. Applying thermal grease on the top of the processor

- a. processor
 - b. thermal grease
 - c. thermal grease syringe
3. Place the heat sink onto the processor.
 4. Tighten one of the four screws to secure the heat sink to the system board.
 5. Repeat the procedure for the remaining two screws.

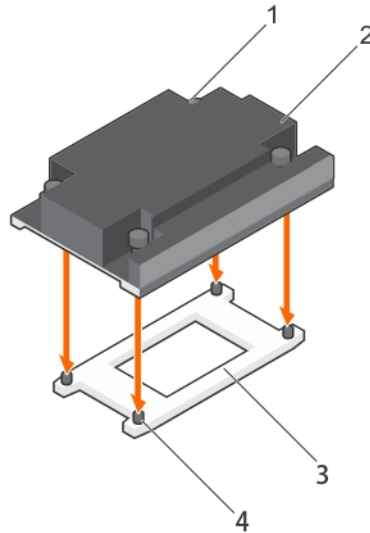

Figure 37. Installing the heat sink

- | | |
|------------------------|-----------------------------|
| 1. retention screw (4) | 2. heat sink |
| 3. processor shield | 4. retention screw slot (4) |

Next steps

1. Follow the procedure listed in the After working inside your system section.
2. While booting, press F2 to enter System Setup and verify that the processor information matches the new system configuration.
3. Run the system diagnostics to verify that the new processor operates correctly.

Related references

[Safety instructions](#) on page 63

Related tasks

[Before working inside your system](#) on page 64

[Installing a processor](#) on page 99

[After working inside your system](#) on page 64

Power supply units

Your system supports two hot swappable 750 W or 1600 W AC power supply units (PSUs). If two PSUs are used, they must be of the same maximum output power.

CAUTION: For AC PSUs, use only PSUs with the Extended Power Performance (EPP) label on the back. Mixing PSUs from previous generations of systems can result in a PSU mismatch condition or failure to turn on.

NOTE: If a system with 1600 W PSUs operates from 100 V to 120 V, then the power rating per PSU is derated to 800 W.

NOTE: When two identical PSUs are installed, power supply redundancy (1+1 – with redundancy or 2+0 – without redundancy) is configured in system BIOS. In redundant mode, power is supplied to the system equally from both PSUs when Hot Spare is disabled. When Hot Spare is enabled, one of the PSUs will be put into standby when system utilization is low to maximize efficiency.

Hot spare feature

Your system supports the hot spare feature that significantly reduces the power overhead associated with power supply unit (PSU) redundancy.

When the hot spare feature is enabled, one of the redundant PSUs is switched to the sleep state. The active PSU supports 100 percent of the load, thus operating at higher efficiency. The PSU in the sleep state monitors output voltage of the active PSU. If the output voltage of the active PSU drops, the PSU in the sleep state returns to an active output state.

If having both PSUs active is more efficient than having one PSU in the sleep state, the active PSU can also activate the sleeping PSU.

The default PSU settings are as follows:

- If the load on the active PSU is more than 50 percent, then the redundant PSU is switched to the active state.
- If the load on the active PSU falls below 20 percent, then the redundant PSU is switched to the sleep state.

You can configure the hot spare feature by using the iDRAC settings. For more information about iDRAC settings, see the *Integrated Dell Remote Access Controller User's Guide* available at Dell.com/idracmanuals.

Removing the power supply unit blank

Install the power supply unit (PSU) blank only in the second PSU bay.

Prerequisites

CAUTION: Many repairs may only be done by a certified service technician. You should only perform troubleshooting and simple repairs as authorized in your product documentation, or as directed by the online or telephone service and support team. Damage due to servicing that is not authorized by Dell is not covered by your warranty. Read and follow the safety instructions that are shipped with your product.

Follow the safety guidelines listed in the Safety instructions section.

Steps

If you are installing a second power supply unit (PSU), remove the PSU blank in the bay by pulling the blank outward.

CAUTION: Remove the PSU blank only if you are installing a second PSU.

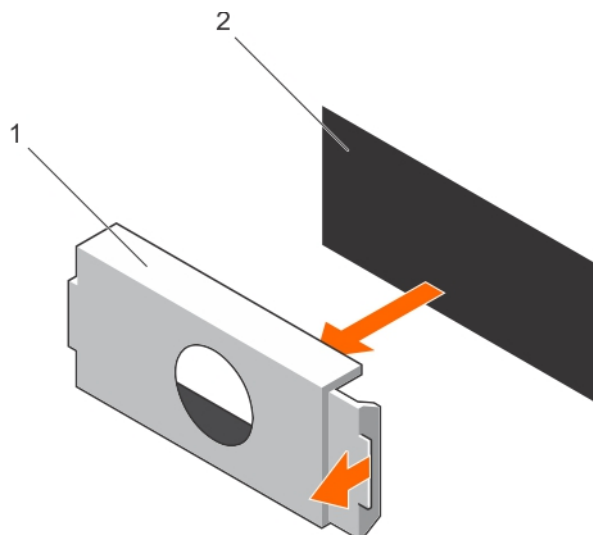

Figure 38. Removing the PSU blank

- a. PSU blank
- b. PSU bay

Next steps

Install the PSU or PSU blank.

Related references

[Safety instructions](#) on page 63

Related tasks

[Installing the power supply unit blank](#) on page 104

Installing the power supply unit blank

Install the power supply unit (PSU) blank only in the second PSU bay.

Prerequisites

CAUTION: Many repairs may only be done by a certified service technician. You should only perform troubleshooting and simple repairs as authorized in your product documentation, or as directed by the online or telephone service and support team. Damage due to servicing that is not authorized by Dell is not covered by your warranty. Read and follow the safety instructions that are shipped with your product.

1. Follow the safety guidelines listed in the Safety instructions section.

Steps

Align the power supply unit blank with the power supply unit slot and push it into the power supply unit slot until it clicks into place.

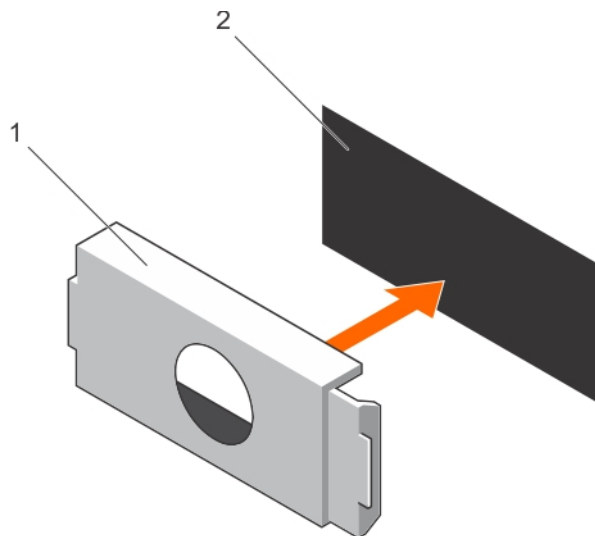

Figure 39. Installing the PSU blank

- a. PSU blank
- b. PSU bay

Related references

[Safety instructions](#) on page 63

Related tasks

[Removing the power supply unit blank](#) on page 103

Removing an AC power supply unit

Prerequisites

CAUTION: Many repairs may only be done by a certified service technician. You should only perform troubleshooting and simple repairs as authorized in your product documentation, or as directed by the online or telephone service and support team. Damage due to servicing that is not authorized by Dell is not covered by your warranty. Read and follow the safety instructions that are shipped with your product.

CAUTION: The system needs one power supply unit (PSU) for normal operation. On power-redundant systems, remove and replace only one PSU at a time in a system that is powered on.

If applicable, unlatch and lift the optional cable management arm if it interferes with the power supply unit (PSU) removal. For information about the cable management arm, see the system's rack documentation.

Follow the safety guidelines listed in the Safety instructions section.

Steps

1. Disconnect the power cable from the power source and from the PSU you intend to remove, and then remove the cables from the strap.
2. Press the release latch and slide the PSU out of the chassis by using the PSU handle.

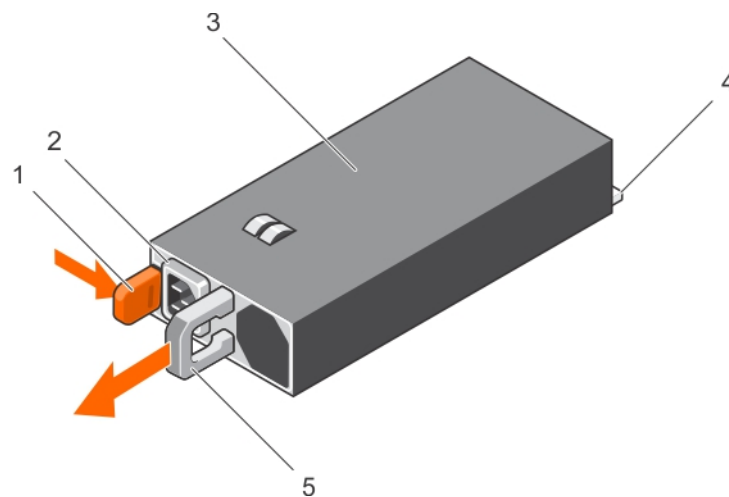

Figure 40. Removing an AC PSU

- | | |
|------------------|------------------------|
| 1. release latch | 2. PSU cable connector |
| 3. PSU | 4. power connector |
| 5. PSU handle | |

Next steps

- If applicable, install the AC PSU.
- If applicable, install the PSU blank.

Related references

[Safety instructions](#) on page 63

Related tasks

[Installing an AC power supply unit](#) on page 106

Installing an AC power supply unit

Prerequisites

CAUTION: Many repairs may only be done by a certified service technician. You should only perform troubleshooting and simple repairs as authorized in your product documentation, or as directed by the online or telephone service and support team. Damage due to servicing that is not authorized by Dell is not covered by your warranty. Read and follow the safety instructions that are shipped with your product.

NOTE: The maximum output power (shown in watts) is listed on the PSU label.

1. Follow the safety guidelines listed in the Safety instructions section.
2. For systems that support redundant power supply units (PSUs), ensure that both the PSUs are of the same type and have the same maximum output power.
3. If installed, remove the PSU blank.

Steps

1. Slide the PSU into the chassis until the PSU is fully seated and the release latch snaps into place.
2. If applicable, relatch the cable management arm.
For information about the cable management arm, see the rack documentation of your system.
3. Connect the power cable to the PSU, and plug the cable into a power outlet.

CAUTION: When connecting the power cable, secure the cable with the strap.

NOTE: When installing, hot swapping, or hot-adding a new PSU, wait for 15 seconds for the system to recognize the PSU and determine its status. The PSU redundancy may not occur until discovery is complete. Wait until the new PSU is discovered and enabled before you remove the other PSU. The PSU status indicator turns green to signify that the PSU is functioning properly.

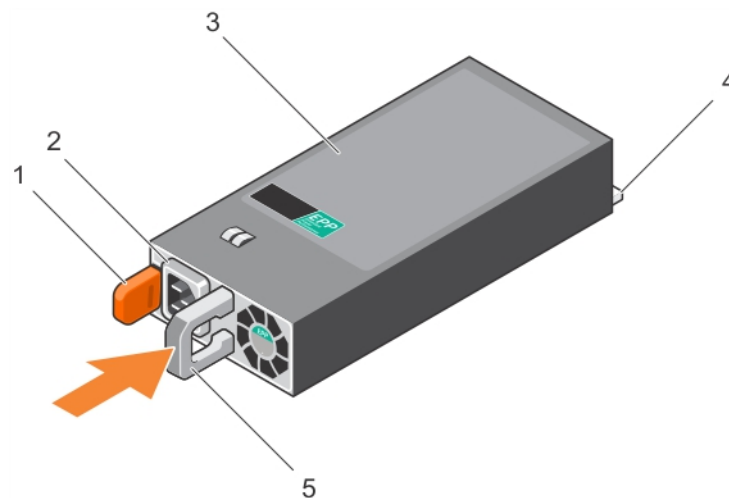

Figure 41. Installing an AC PSU

- | | |
|------------------|------------------------|
| 1. release latch | 2. PSU cable connector |
| 3. PSU | 4. power connector |
| 5. PSU handle | |

Related references

[Safety instructions](#) on page 63

Integrated storage controller card

Your system includes a dedicated expansion card slot on the system board for an integrated storage controller card. The integrated storage controller card provides the integrated storage subsystem for the internal hard drives in your system. The controller supports SAS and SATA hard drives and also enables you to set up the hard drives in RAID configurations. The RAID configurations depend on the version of the storage controller included with your system. The controller supports SAS hard drives.

Removing the integrated storage controller card

Prerequisites

CAUTION: Many repairs may only be done by a certified service technician. You should only perform troubleshooting and simple repairs as authorized in your product documentation, or as directed by the online or telephone service and support team. Damage due to servicing that is not authorized by Dell is not covered by your warranty. Read and follow the safety instructions that are shipped with your product.

1. Follow the safety guidelines listed in the Safety instructions section.
2. Follow the procedure listed in the Before working inside your system section.
3. Remove the cooling shroud.
4. Keep the Phillips #2 screwdriver ready.

Steps

1. Lift the expansion card latch out of the slot.
2. Pull and slide the card out from the connector on riser card 3.

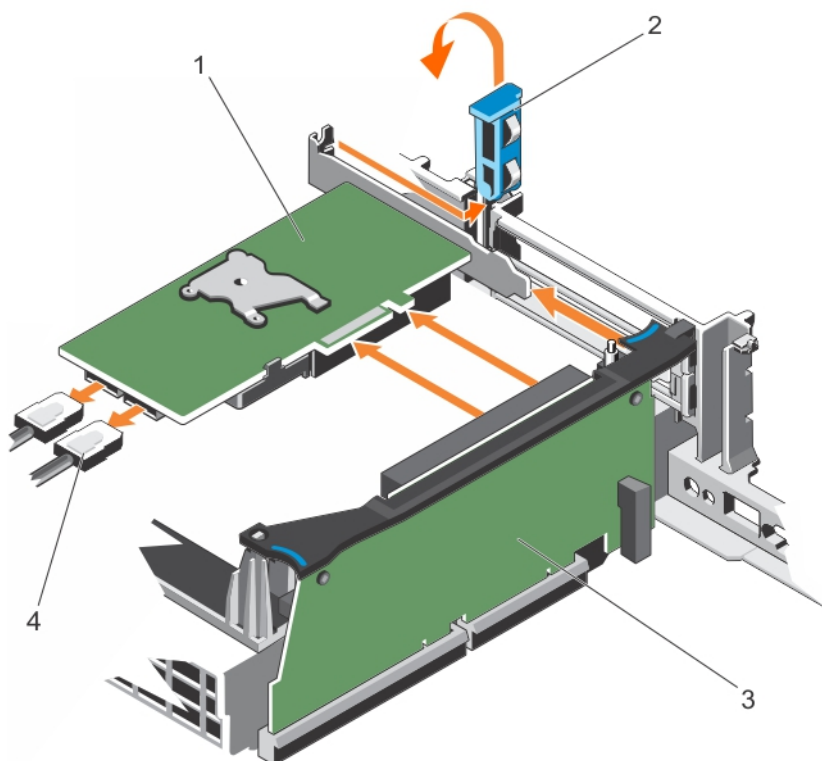



Figure 42. Removing the integrated storage controller card

- | | |
|----------------------------|-------------------------|
| 1. storage controller card | 2. expansion card latch |
| 3. riser card 3 | 4. SAS cable (2) |

3. Disconnect the cables connected to the card by performing the following steps:
 - a. Press the latch on the SAS cable connector.
 - b. Pull the SAS cable out of the connector.
4. If you are removing the expansion card permanently, install the filler bracket.

Next steps

1. If applicable, install the integrated storage controller card.
 -  **NOTE:** Ensure that the H330, H730, H730P, or HBA330 card is installed only on slot number seven of the expansion card riser.
2. Install the cooling shroud.
3. Follow the procedure listed in the After working inside your system section.

Related references

[Safety instructions](#) on page 63

Related tasks

[Before working inside your system](#) on page 64

[Removing the cooling shroud](#) on page 76

[Installing the integrated storage controller card](#) on page 108

[Installing the cooling shroud](#) on page 77

[After working inside your system](#) on page 64

Installing the integrated storage controller card

Prerequisites

 **CAUTION:** Many repairs may only be done by a certified service technician. You should only perform troubleshooting and simple repairs as authorized in your product documentation, or as directed by the online or telephone service and support team. Damage due to servicing that is not authorized by Dell is not covered by your warranty. Read and follow the safety instructions that are shipped with your product.

1. Follow the safety guidelines listed in the Safety instructions section.
2. Follow the procedure listed in the Before working inside your system section.
3. If installed, remove the cooling shroud.

Steps

1. Open the expansion-card latch and remove the filler bracket.
 -  **NOTE:** Ensure that the H330, H730, H730P, and HBA330 cards are installed only on slot number seven of the expansion card riser.
2. Holding the card by its edges, align the connector on the card with the connector on the expansion card riser.
3. Insert the card firmly into the expansion card connector until the card is fully seated.
4. Close the expansion card latch.

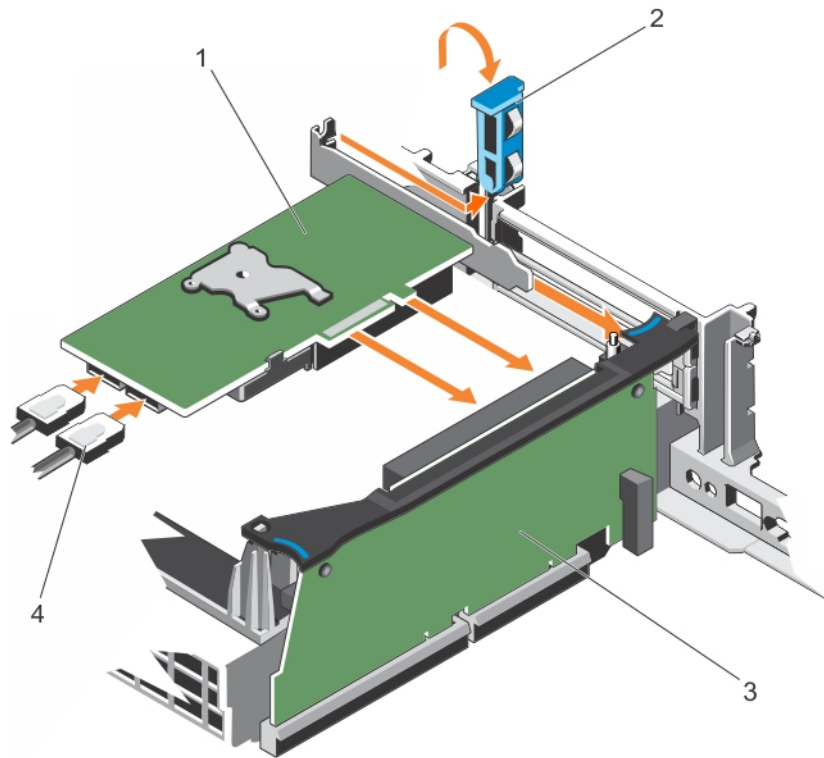

Figure 43. Installing the integrated storage controller card

- | | |
|---------------------------------------|-------------------------|
| 1. integrated storage controller card | 2. expansion card latch |
| 3. riser 3 | 4. SAS cable |

5. Connect the SAS data cables to the SAS data cable connectors on the integrated storage controller card.

NOTE: Ensure that you connect the cable according to the connector labels on the cable. The cable does not function properly if reversed.

6. Connect the SAS data cable to the system board.

Next steps

1. Install the expansion card riser 1.
2. If applicable, install the cooling shroud.
3. Follow the procedure listed in the After working inside your system section.

Related references

[Safety instructions](#) on page 63

Related tasks

- [Before working inside your system](#) on page 64
- [Removing the cooling shroud](#) on page 76
- [Installing the cooling shroud](#) on page 77
- [Installing an expansion card into expansion card riser 1](#) on page 120
- [After working inside your system](#) on page 64

Expansion cards and expansion card riser

An expansion card in the system is an add-on card that can be inserted into an expansion slot on the system board or riser card to add enhanced functionality to the system through the expansion bus.

NOTE: A System Event Log (SEL) event is logged if an expansion card riser is unsupported or missing. It does not prevent your system from turning on and no BIOS POST message or F1/F2 pause is displayed.

Expansion card installation guidelines

Depending on your system configuration, the following PCI Express (PCIe) generation 3 expansion cards are supported:

Table 33. Supported expansion cards

Riser	PCIe Slot	Processor Connection	Height	Length	Link Width	Slot Width
1	1	Processor 2	Full Height	Half Length	x16	x16
1	2	Processor 2	Full Height	Half Length	x8	x16
2	3	Processor 1	Low Profile	Half Length	x8	x16
2	4	Processor 2	Low Profile	Half Length	x8	x16
2	5	Processor 2	Low Profile	Half Length	x8	x16
3	6	Processor 1	Full Height	Half Length	x16	x16
3	7	Processor 1	Full Height	Half Length	x8	x8

NOTE: To use the PCIe slots 1, 2, 4, and 5 on the risers, processors 1 and 2 must be installed.

NOTE: The expansion card slots are not hot-swappable.

The following table provides guidelines for installing expansion cards to ensure proper cooling and mechanical fit. The expansion cards with the highest priority should be installed first using the slot priority indicated. All the other expansion cards should be installed in the card priority and slot priority order.

Table 34. Expansion card installation order

Card Priority	Card Type	Form Factor	Slot Priority	Max Allowed
1	Internal Storage (Integrated Slot)	Full Height	7, 6	2
2	External SAS Controllers	Full Height	7, 6, 2, 1	2
		Low Profile	3, 4, 5	3
3	Fibre Channel 16 Gb	Full Height	7, 6, 2	3
		Low Profile	3, 4, 5	3
4	Converged Network Adapters	Full Height	7, 6, 2	3
		Low Profile	3, 4, 5	2
5	40 Gb InfiniBand	Full Height	7, 6, 2	3
		Low Profile	3, 4, 5	2
6	10 Gb Ethernet Controllers	Full Height	7, 6, 2	3
		Low Profile	3, 4	2
		Low Profile	3, 4, 5	2
7	Fibre Channel 8 Gb Dual Port	Full Height	7, 6, 2	3

Table 34. Expansion card installation order (continued)

Card Priority	Card Type	Form Factor	Slot Priority	Max Allowed
		Low Profile	3, 4, 5	2
8	Fibre Channel 8 Gb Single Port	Full Height	7, 6, 2	3
		Low Profile	3, 4, 5	3
9	Fibre Channel 4 Gb Single/ Dual Port	Full Height	7, 6, 2	3
10	1 Gb NICs	Low Profile	3, 4	2
		Full Height	7, 6, 2	3
11	External Non-RAID Controller	Full Height	7, 6, 2, 1	3
12	NVMe PCIe SSD card	Full Height	7, 6, 2, 1	2
		Full Height (Low Profile)	7, 6, 2, 1 (3, 4)	4
		Full Height , Half Length	6, 1, 2, 7	4
13	Mellanox ConnectX-4	Full Height	6, 1	2

Removing expansion card risers

Prerequisites

CAUTION: Many repairs may only be done by a certified service technician. You should only perform troubleshooting and simple repairs as authorized in your product documentation, or as directed by the online or telephone service and support team. Damage due to servicing that is not authorized by Dell is not covered by your warranty. Read and follow the safety instructions that are shipped with your product.

1. Follow the safety guidelines listed in the Safety instructions section.
2. Follow the procedure listed in the Before working inside your system section.

Steps

1. Holding the slots on the expansion card riser, lift the riser from the riser connector on the system board.
2. To remove expansion card riser 3, hold the edges of the expansion card riser.

NOTE: To ensure proper system cooling, the riser blank must be installed in the appropriate riser slot. Remove the riser blank only if you are installing a riser.

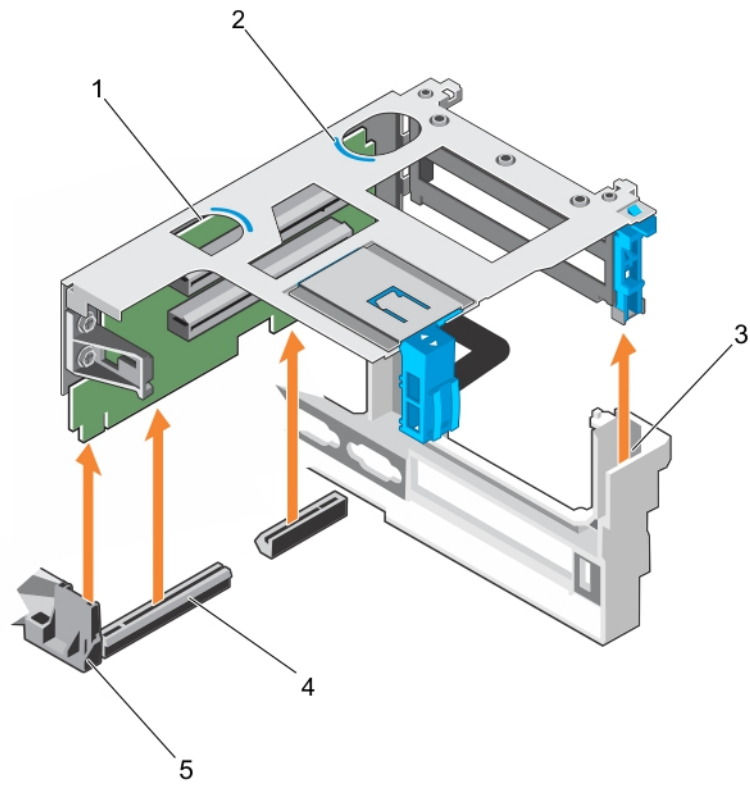

Figure 44. Removing the expansion card riser 1

- | | |
|---------------------------|-------------------------------------|
| 1. expansion card riser 1 | 2. touch point (2) |
| 3. riser guide (right) | 4. expansion card riser 1 connector |
| 5. riser guide (left) | |

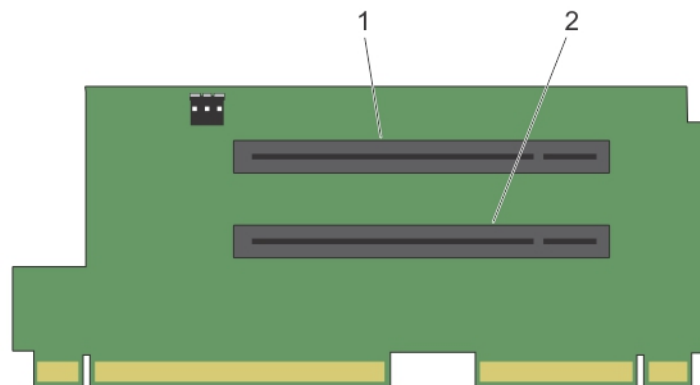

Figure 45. Connectors on the expansion card riser 1

- a. expansion card connector slot 1
- b. expansion card connector slot 2

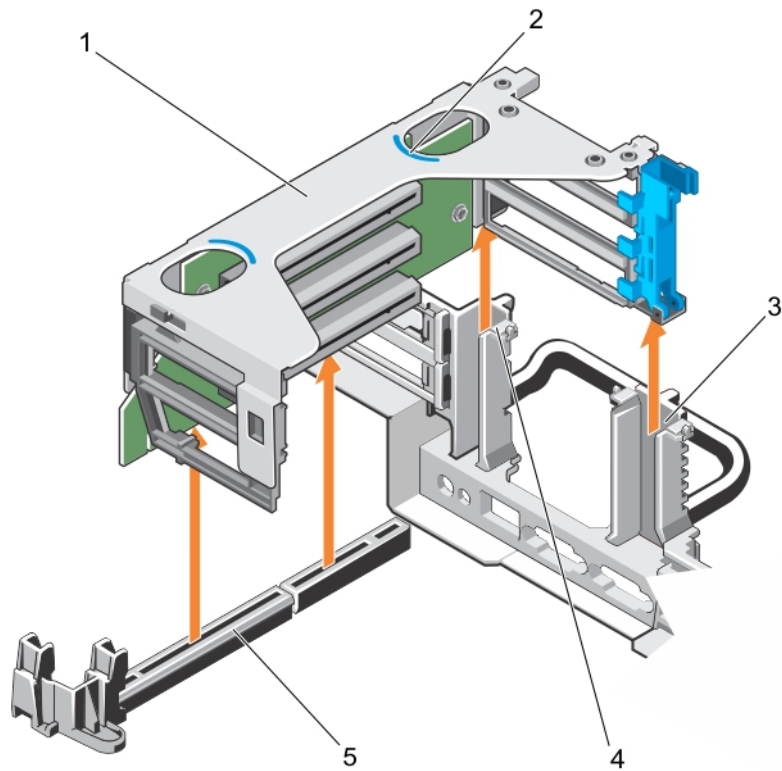

Figure 46. Removing the expansion card riser 2

- | | |
|-------------------------------------|-----------------------|
| 1. expansion card riser 2 | 2. touch point (2) |
| 3. riser guide (right) | 4. riser guide (left) |
| 5. expansion card riser 2 connector | |

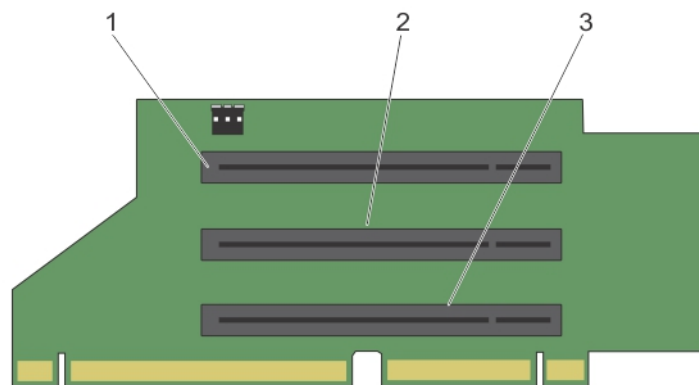

Figure 47. Connectors on the expansion card riser 2

- a. expansion card connector slot 3
- b. expansion card connector slot 4
- c. expansion card connector slot 5

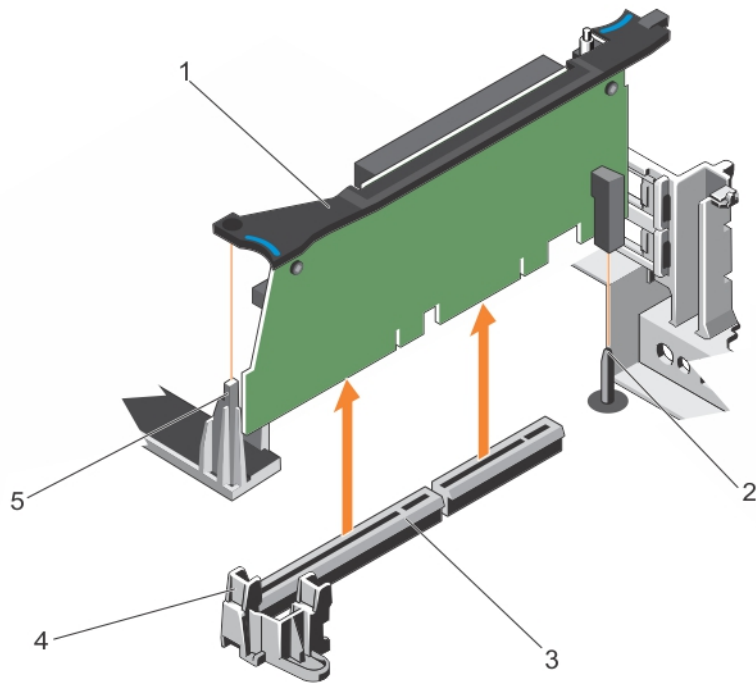

Figure 48. Removing the expansion card riser 3

- | | |
|-------------------------------------|-----------------------------|
| 1. expansion card riser 3 | 2. guide pin on the chassis |
| 3. expansion card riser 3 connector | 4. riser guide (right) |
| 5. riser guide (left) | |

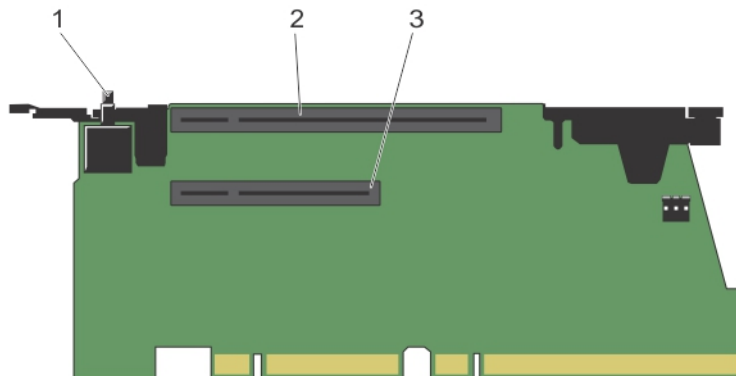

Figure 49. Connectors on the expansion card riser 3

- a. chassis intrusion switch
- b. expansion card connector slot 6
- c. expansion card connector slot 7

Next steps

1. If removed, install an expansion card on the riser.
2. If applicable, replace the expansion card riser.
3. Follow the procedure listed in the After working inside your system section.

Related references

[Safety instructions](#) on page 63

Related tasks

[Before working inside your system](#) on page 64

[Installing expansion card risers](#) on page 115

[After working inside your system](#) on page 64

Installing expansion card risers

Prerequisites

1. Follow the safety guidelines listed in the Safety instructions section.
2. Follow the procedure listed in the Before working inside your system section.
3. If applicable, install the expansion card(s) into the expansion card riser(s).

 **CAUTION: Many repairs may only be done by a certified service technician. You should only perform troubleshooting and simple repairs as authorized in your product documentation, or as directed by the online or telephone service and support team. Damage due to servicing that is not authorized by Dell is not covered by your warranty. Read and follow the safety instructions that are shipped with your product.**

Steps

1. Align the expansion card riser with the connectors and the riser guides on the system board.
2. Lower the expansion card riser into place until the expansion card riser is fully seated in the connector.

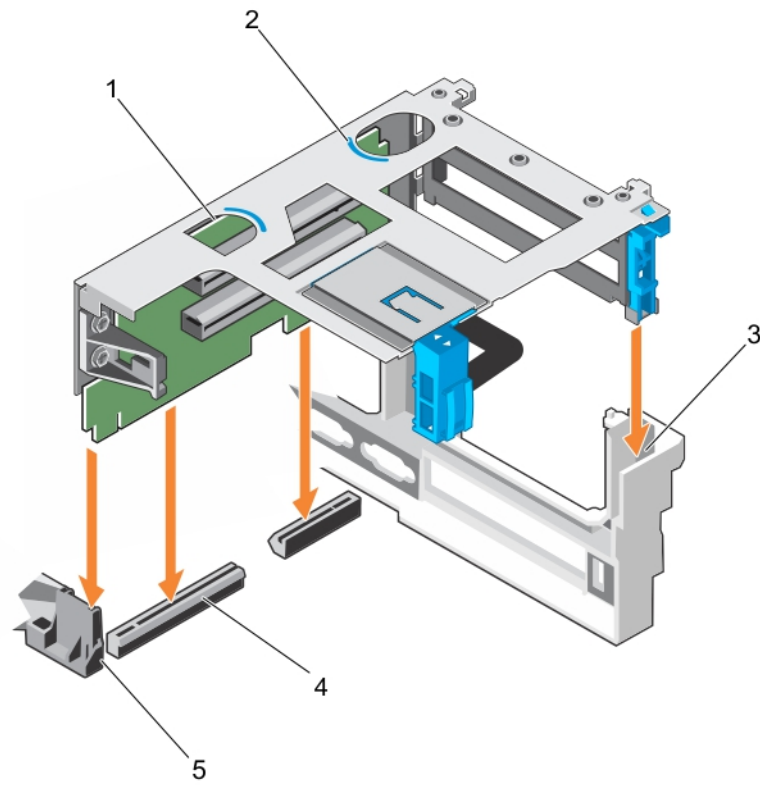

Figure 50. Installing the expansion card riser 1

- 1. expansion card riser 1
- 2. touch point (2)
- 3. riser guide (back)
- 4. expansion card riser 1 connector
- 5. riser guide-front

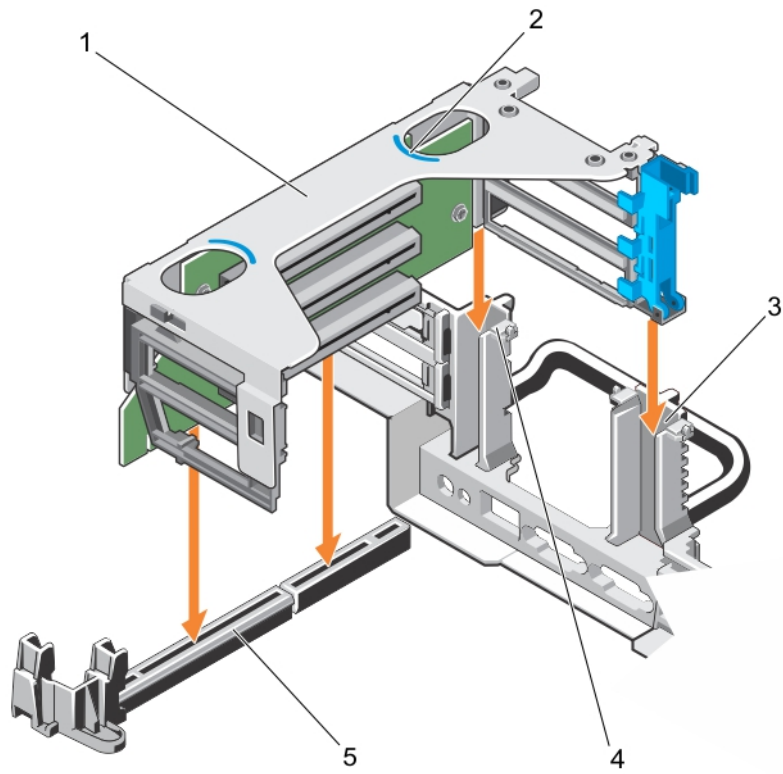

Figure 51. Installing the expansion card riser 2

- | | |
|-------------------------------------|-----------------------|
| 1. expansion card riser 2 | 2. touch point (2) |
| 3. riser guide (right) | 4. riser guide (left) |
| 5. expansion card riser 2 connector | |

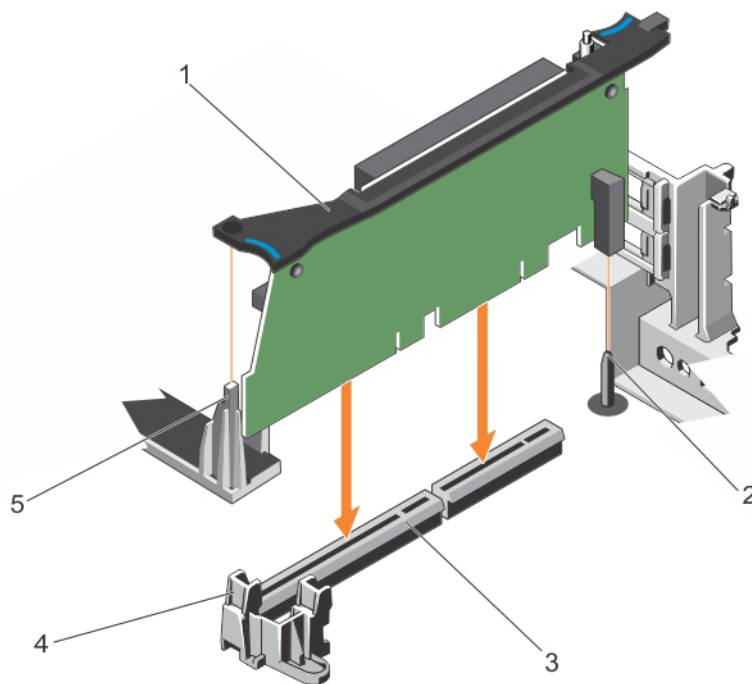

Figure 52. Installing the expansion card riser 3

- | | |
|-------------------------------------|-----------------------------|
| 1. expansion card riser 3 | 2. guide pin on the chassis |
| 3. expansion card riser 3 connector | 4. riser guide front |
| 5. riser guide back | |

Next steps

1. Follow the procedure listed in the After working inside your system section.
2. Install any device drivers required for the card as described in the documentation for the card.

Related references

[Safety instructions](#) on page 63

Related tasks

[Before working inside your system](#) on page 64

[Removing expansion card risers](#) on page 111

[After working inside your system](#) on page 64

Removing an expansion card from expansion card riser 1

Prerequisites

CAUTION: Many repairs may only be done by a certified service technician. You should only perform troubleshooting and simple repairs as authorized in your product documentation, or as directed by the online or telephone service and support team. Damage due to servicing that is not authorized by Dell is not covered by your warranty. Read and follow the safety instructions that are shipped with your product.

1. Follow the safety guidelines listed in the Safety instructions section.

2. Follow the procedure listed in the Before working inside your system section.
3. Holding the touch points on the expansion card riser, lift the expansion card riser out of the chassis.

Steps

1. Disconnect any cables connected to the expansion card.
2. Press the expansion card retention latch and pull it open from the expansion card riser.
3. Pull the expansion card release latch open.
4. Hold the expansion card by its edges, and remove it from the expansion card connector.
5. If you are removing the card permanently, install a metal filler bracket over the empty expansion slot opening and close the expansion card latch.

NOTE: You must install a filler bracket over an empty expansion card slot to maintain Federal Communications Commission (FCC) certification of the system. The brackets also keep dust and dirt out of the system and aid in proper cooling and airflow inside the system. The filler bracket is necessary to maintain proper thermal conditions.

6. Push the expansion card release latch to close.
7. Close the expansion card retention latch into the slot.

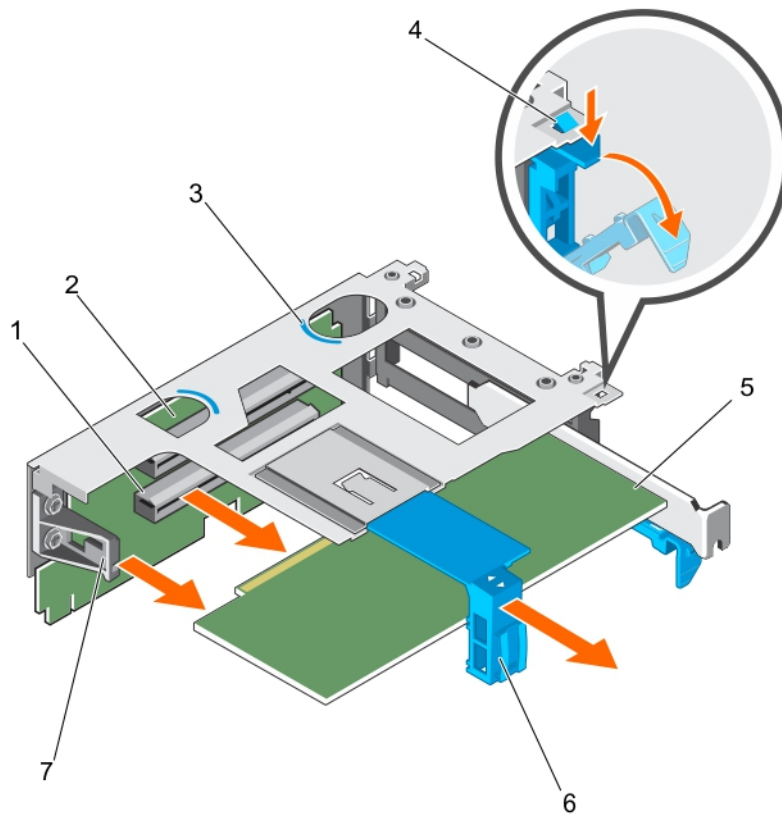

Figure 53. Removing an expansion card from expansion card riser 1

- | | |
|-----------------------------|---|
| 1. expansion card connector | 2. expansion card riser 1 |
| 3. touch point (2) | 4. expansion card riser retention latch |
| 5. expansion card | 6. expansion card release latch |
| 7. expansion card riser tab | |

Next steps

1. Install the expansion card riser 1.
2. Follow the procedure listed in the After working inside your system section.

Related references

[Safety instructions](#) on page 63

Related tasks

[Before working inside your system](#) on page 64

[Installing an expansion card into expansion card riser 1](#) on page 120

[After working inside your system](#) on page 64

Installing an expansion card into expansion card riser 1

Prerequisites

 **CAUTION:** Many repairs may only be done by a certified service technician. You should only perform troubleshooting and simple repairs as authorized in your product documentation, or as directed by the online or telephone service and support team. Damage due to servicing that is not authorized by Dell is not covered by your warranty. Read and follow the safety instructions that are shipped with your product.

1. Follow the safety guidelines listed in the Safety instructions section.
2. Follow the procedure listed in the Before working inside your system section.
3. Remove the expansion card riser 1.

Steps

1. If applicable, unpack the expansion card and prepare it for installation. For instructions, see the documentation accompanying the card.
2. Press the expansion card retention latch and pull it open from the expansion card riser.
3. Pull the expansion card release latch open.
4. Holding the card by its edges, insert the card edge connector firmly into the expansion card connector until the card is fully seated.

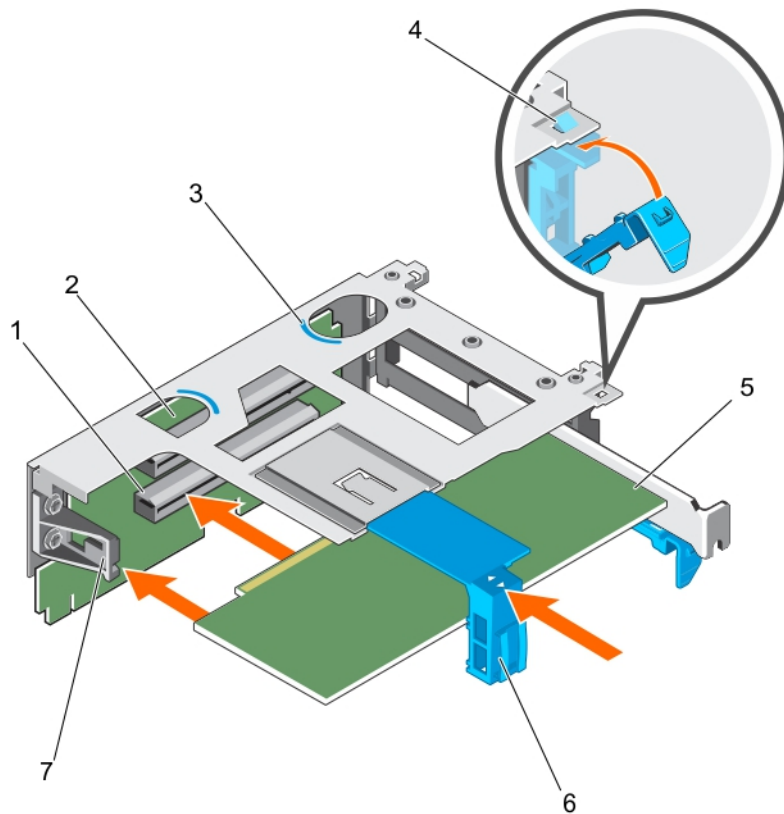

Figure 54. Installing an expansion card into the expansion card riser 1

- | | |
|-----------------------------|-----------------------------------|
| 1. expansion card connector | 2. expansion card riser 1 |
| 3. touch point (2) | 4. expansion card retention latch |
| 5. expansion card | 6. expansion card release latch |
| 7. expansion card riser tab | |

5. Push the expansion card release latch to close.
6. Close the expansion card retention latch into the slot.

Next steps

1. Follow the procedure listed in the After working inside your system section.
2. Install any device drivers needed for the card as described in the documentation for the card.

Related references

[Safety instructions](#) on page 63

Related tasks

[Before working inside your system](#) on page 64

[Removing an expansion card from expansion card riser 1](#) on page 118

[After working inside your system](#) on page 64

Removing an expansion card from expansion card riser 2

Prerequisites

CAUTION: Many repairs may only be done by a certified service technician. You should only perform troubleshooting and simple repairs as authorized in your product documentation, or as directed by the online or

telephone service and support team. Damage due to servicing that is not authorized by Dell is not covered by your warranty. Read and follow the safety instructions that are shipped with your product.

1. Follow the safety guidelines listed in the Safety instructions section.
2. Follow the procedure listed in the Before working inside your system section.
3. Holding the touch points on the riser, lift the expansion-card riser out of the chassis.

Steps

1. Disconnect any cables connected to the expansion card.
2. Press the expansion card retention latch and pull it open from the expansion card riser.

i **NOTE:** For a full-height expansion card, pull the expansion card holder away from the expansion card riser.

3. Hold the expansion card by its edges, and remove it from the expansion card connector.
4. If you are removing the card permanently, install a metal filler bracket over the empty expansion slot opening and close the expansion card latch.

i **NOTE:** You must install a filler bracket over an empty expansion card slot to maintain Federal Communications Commission (FCC) certification of the system. The brackets also keep dust and dirt out of the system and aid in proper cooling and airflow inside the system. The filler bracket is necessary to maintain proper thermal conditions.

5. Close the expansion card riser latch into the slot.

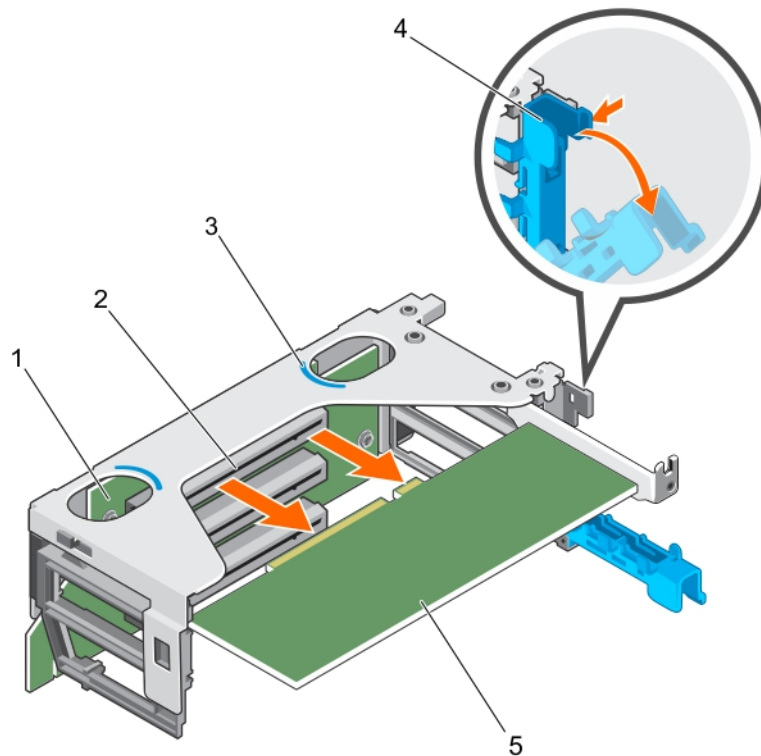

Figure 55. Removing an expansion card from expansion card riser 2

- | | |
|---------------------------|-----------------------------|
| 1. expansion card riser 2 | 2. expansion card connector |
| 3. touch point (2) | 4. expansion card latch |
| 5. expansion card | |

Next steps

1. Install the expansion card riser 2.

2. Follow the procedure listed in the After working inside your system section.

Related references

[Safety instructions](#) on page 63

Related tasks

[Before working inside your system](#) on page 64

[Installing an expansion card into expansion card riser 2](#) on page 123

[After working inside your system](#) on page 64

Installing an expansion card into expansion card riser 2

Prerequisites

 **CAUTION:** Many repairs may only be done by a certified service technician. You should only perform troubleshooting and simple repairs as authorized in your product documentation, or as directed by the online or telephone service and support team. Damage due to servicing that is not authorized by Dell is not covered by your warranty. Read and follow the safety instructions that are shipped with your product.

1. Follow the safety guidelines listed in the Safety instructions section.
2. Follow the procedure listed in the Before working inside your system section.
3. Remove the expansion card riser 2.

Steps

1. If applicable, unpack the expansion card and prepare it for installation. For instructions, see the documentation accompanying the card.
2. Open the expansion card latch and remove the filler bracket.
3. Holding the card by its edges, insert the card edge connector firmly into the expansion card connector until the card is fully seated.

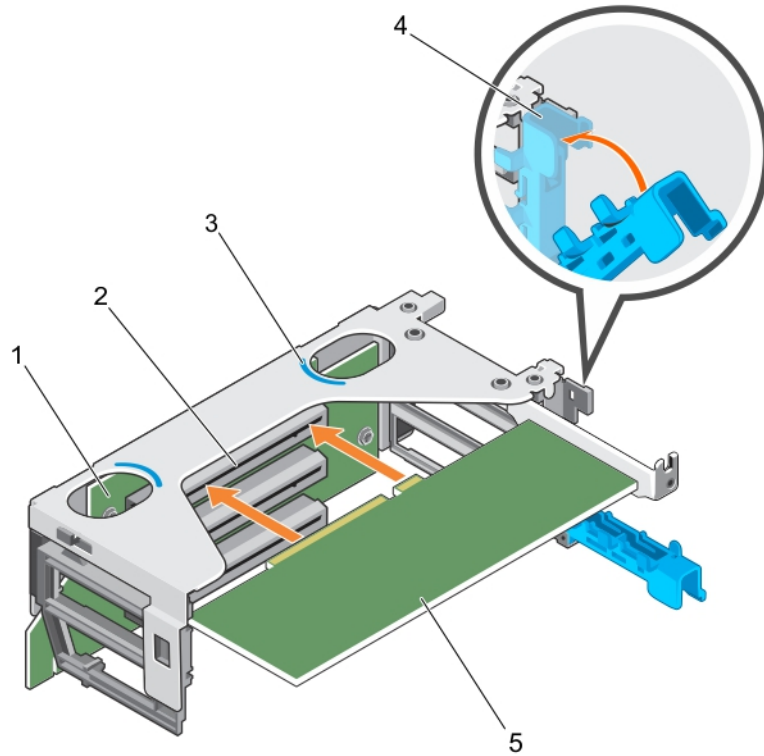

Figure 56. Installing an expansion card into the expansion card riser 2

- | | |
|---------------------------|-----------------------------|
| 1. expansion card riser 2 | 2. expansion card connector |
| 3. touch point (2) | 4. expansion card latch |
| 5. expansion card | |

4. Close the expansion card latch into the slot.

Next steps

1. Install the expansion card riser 2.
2. Follow the procedure listed in the After working inside your system section.
3. Install any device drivers needed for the card as described in the documentation for the card.

Related references

[Safety instructions](#) on page 63

Related tasks

[Before working inside your system](#) on page 64

[Removing an expansion card from expansion card riser 2](#) on page 121

[After working inside your system](#) on page 64

Removing an expansion card from the expansion card riser 3

Prerequisites

CAUTION: Many repairs may only be done by a certified service technician. You should only perform troubleshooting and simple repairs as authorized in your product documentation, or as directed by the online or telephone service and support team. Damage due to servicing that is not authorized by Dell is not covered by your warranty. Read and follow the safety instructions that are shipped with your product.

1. Follow the safety guidelines listed in the Safety instructions section.
2. Follow the procedure listed in the Before working inside your system section.
3. Holding the touch points on the riser, lift the expansion card riser out of the chassis.

Steps

1. Disconnect any cables connected to the expansion card.
2. Open the expansion card retention latch.

i **NOTE:** If you are removing a full-height expansion card, open the expansion card holder.

3. Hold the expansion card by its edges, and remove it from the expansion card connector.
4. If you are removing the card permanently, install a metal filler bracket over the empty expansion slot opening and close the expansion card latch.

i **NOTE:** You must install a filler bracket over an empty expansion card slot to maintain Federal Communications Commission (FCC) certification of the system. The brackets also keep dust and dirt out of the system and aid in proper cooling and airflow inside the system. The filler bracket is necessary to maintain proper thermal conditions.

5. Close the expansion card riser latch into the slot.

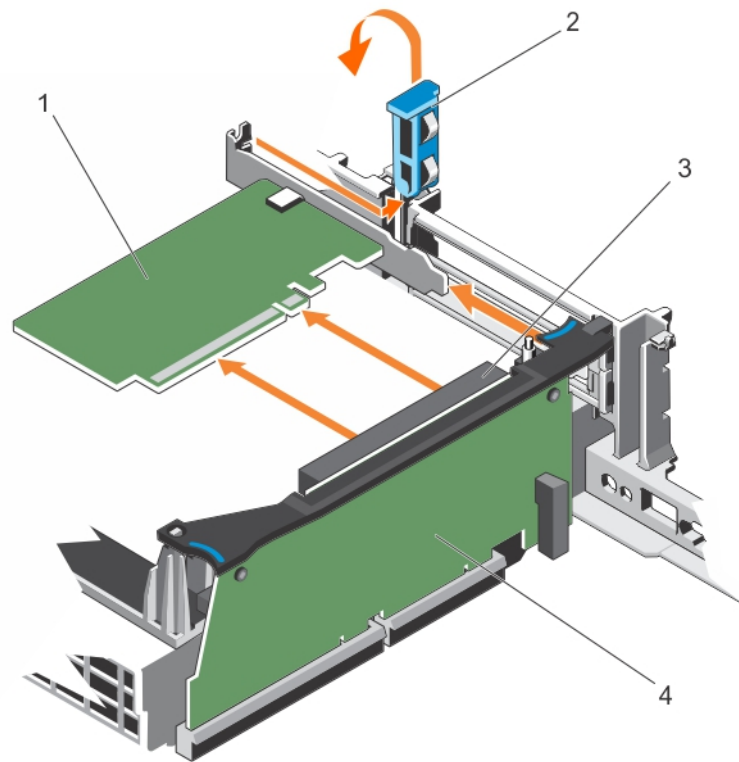

Figure 57. Removing a half-height expansion card from the expansion card riser 3

- | | |
|-----------------------------|-----------------------------------|
| 1. expansion card | 2. expansion card retention latch |
| 3. expansion card connector | 4. expansion card riser |

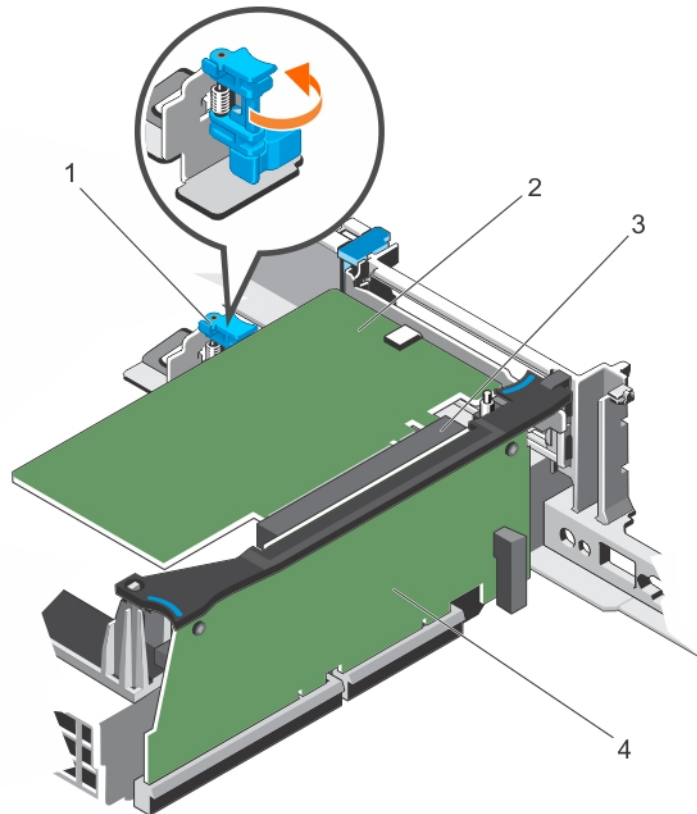

Figure 58. Removing a full-height expansion card from the expansion card riser 3

- | | |
|-----------------------------|---------------------------|
| 1. expansion card holder | 2. expansion card |
| 3. expansion card connector | 4. expansion card riser 3 |

Next steps

1. Install the expansion card riser 3.
2. Follow the procedure listed in the After working inside your system section.

Related references

[Safety instructions](#) on page 63

Related tasks

[Before working inside your system](#) on page 64

[Installing an expansion card into expansion card riser 3](#) on page 126

[After working inside your system](#) on page 64

Installing an expansion card into expansion card riser 3

Prerequisites

⚠ CAUTION: Many repairs may only be done by a certified service technician. You should only perform troubleshooting and simple repairs as authorized in your product documentation, or as directed by the online or telephone service and support team. Damage due to servicing that is not authorized by Dell is not covered by your warranty. Read and follow the safety instructions that are shipped with your product.

1. Follow the safety guidelines listed in the Safety instructions section.
2. Follow the procedure listed in the Before working inside your system section.

3. Remove the expansion card riser 3.

Steps

1. If applicable, unpack the expansion card and prepare it for installation.
For instructions, see the documentation accompanying the card.
2. Open the expansion card retention latch.
3. Holding the card by its edges, insert the card-edge connector firmly into the expansion card connector until the card is fully seated.
4. If you are installing a full-height expansion card, pull the expansion card holder toward the expansion card riser. Ensure that the expansion card rests between the grooves on the expansion card holder.
5. Close the expansion card riser latch into the slot.

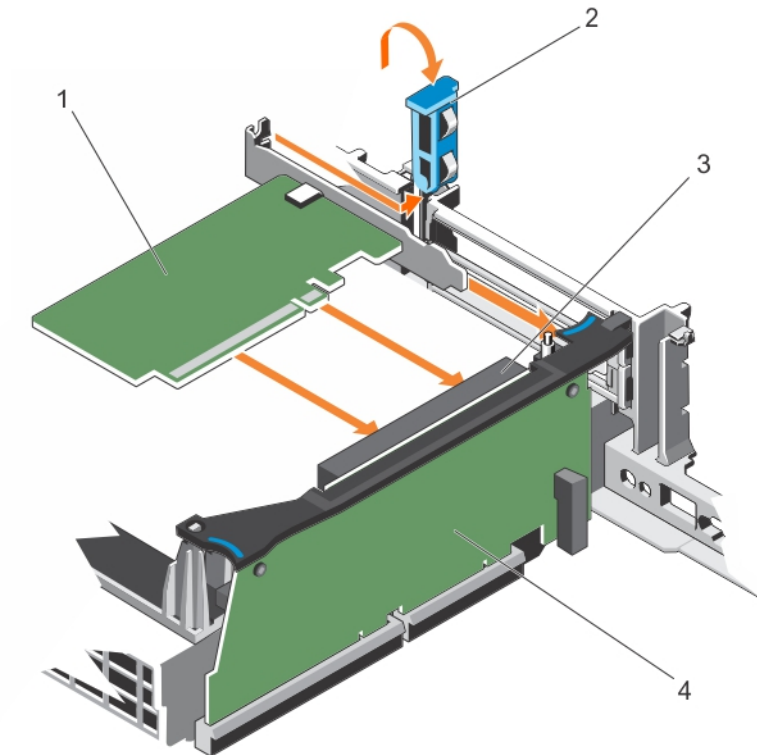

Figure 59. Installing a half-height expansion card into the expansion card riser 3

- | | |
|-----------------------------|-----------------------------------|
| 1. expansion card | 2. expansion card retention latch |
| 3. expansion card connector | 4. expansion card riser |

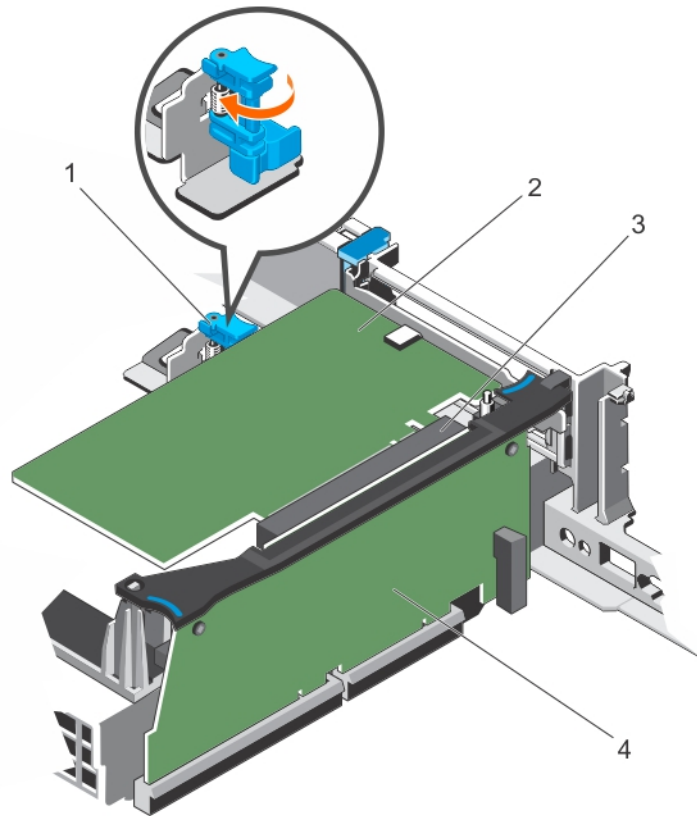

Figure 60. Installing a full-height expansion card into the expansion card riser 3

- | | |
|-----------------------------|---------------------------|
| 1. expansion card holder | 2. expansion card |
| 3. expansion card connector | 4. expansion card riser 3 |

Next steps

1. If applicable, connect any cables to the expansion card.
2. Install any device drivers needed for the card as described in the documentation for the card.
3. Follow the procedure listed in the After working inside your system section.

Related references

[Safety instructions](#) on page 63

Related tasks

[Before working inside your system](#) on page 64

[Removing an expansion card from the expansion card riser 3](#) on page 124

[After working inside your system](#) on page 64

IDSDM

The Internal Dual SD module (IDSDM) provides you with a redundant SD card solution. You can configure the IDSDM for storage or as the OS boot partition. The IDSDM card offers the following features:

- Dual card operation — maintains a mirrored configuration by using SD cards in both the slots and provides redundancy.
 - ⓘ **NOTE:** When the **Redundancy** option is set to **Mirror Mode** in the **Integrated Devices** screen of System Setup, the information is replicated from one SD card to another.
- Single card operation — single card operation is supported, but without redundancy.

Removing an internal SD card

Prerequisites

1. Follow the safety guidelines listed in the Safety instructions section.
2. Follow the procedure listed in the Before working inside your system section.

CAUTION: Many repairs may only be done by a certified service technician. You should only perform troubleshooting and simple repairs as authorized in your product documentation, or as directed by the online or telephone service and support team. Damage due to servicing that is not authorized by Dell is not covered by your warranty. Read and follow the safety instructions that are shipped with your product.

NOTE: Temporarily label each SD card with its corresponding slot number before removal. Reinstall the SD card(s) into the corresponding slots.

Steps

Locate the SD card slot on the internal dual SD module, and press the card to release it from the slot.

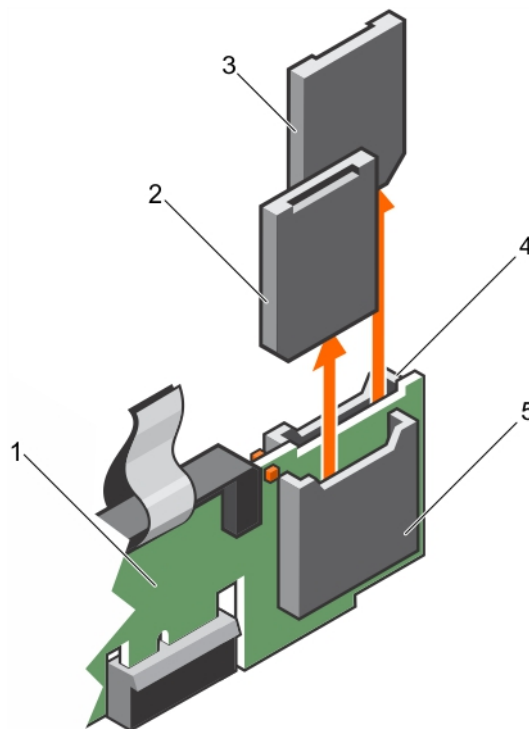

Figure 61. Removing an internal SD card

- | | |
|-------------------|-------------------|
| 1. IDSDM | 2. SD card 1 |
| 3. SD card 2 | 4. SD card slot 2 |
| 5. SD card slot 1 | |

Next steps

Follow the procedure listed in the After working inside your system section.

Related references

[Safety instructions](#) on page 63

Related tasks

[Before working inside your system](#) on page 64

[Installing an internal SD card](#) on page 130

Installing an internal SD card

Prerequisites

1. Follow the safety guidelines listed in the Safety instructions section.
2. Follow the procedure listed in the Before working inside your system section.

CAUTION: Many repairs may only be done by a certified service technician. You should only perform troubleshooting and simple repairs as authorized in your product documentation, or as directed by the online or telephone service and support team. Damage due to servicing that is not authorized by Dell is not covered by your warranty. Read and follow the safety instructions that are shipped with your product.

NOTE: To use an SD card with your system, ensure that the **Internal SD Card Port** is enabled in System Setup.

NOTE: Temporarily label each SD card with its corresponding slot number before removal. Re-install the SD card(s) into the corresponding slots.

Steps

1. Locate the SD card connector on the internal dual SD module. Orient the SD card appropriately and insert the contact-pin end of the card into the slot.

NOTE: The slot is keyed to ensure correct insertion of the card.

2. Press the card into the card slot to lock it into place.

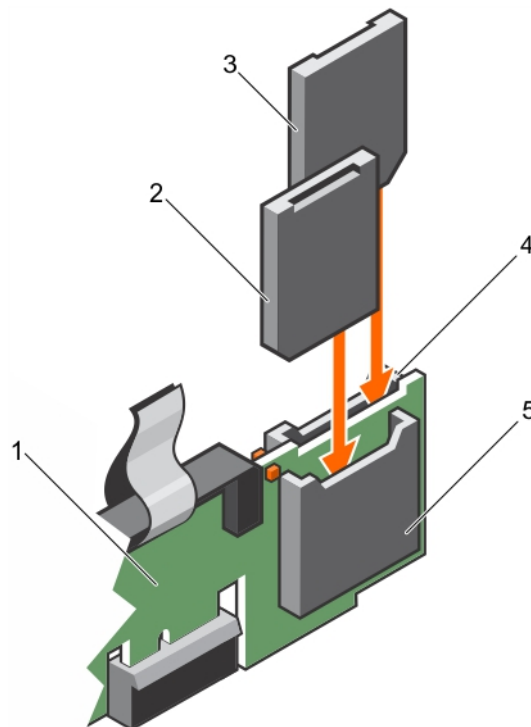

Figure 62. Installing an internal SD card

- | | |
|-------------------|-------------------|
| 1. IDSDM | 2. SD card 2 |
| 3. SD card 1 | 4. SD card slot 1 |
| 5. SD card slot 2 | |

Next steps

Follow the procedure listed in the After working inside your system section.

Related references

[Safety instructions](#) on page 63

Related tasks

[Before working inside your system](#) on page 64

[After working inside your system](#) on page 64

Removing the optional internal dual SD module

Prerequisites

CAUTION: Many repairs may only be done by a certified service technician. You should only perform troubleshooting and simple repairs as authorized in your product documentation, or as directed by the online or telephone service and support team. Damage due to servicing that is not authorized by Dell is not covered by your warranty. Read and follow the safety instructions that are shipped with your product.

1. Follow the safety guidelines listed in the Safety instructions section.
2. Follow the procedure listed in the Before working inside your system section.
3. If installed, remove the SD cards.

NOTE: Temporarily label each SD card with its corresponding slot number before removal. Reinstall the SD cards into the corresponding slots.

Steps

1. Locate the internal dual SD module (IDSDM) on the system board. To locate the internal dual SD module connector, see the System board connectors section.
2. Holding the pull tab, lift the IDSDM out of the system.

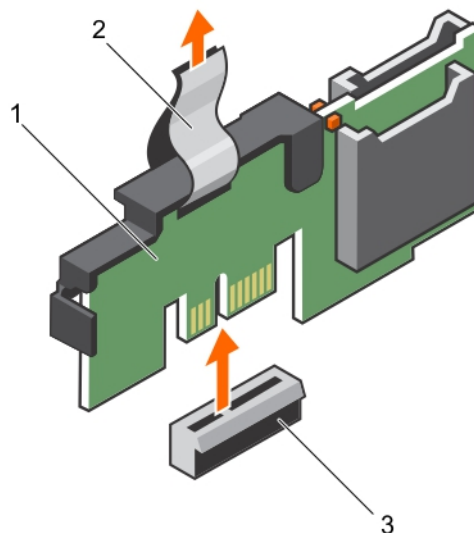

Figure 63. Removing the internal dual SD module (IDSDM)

- a. IDSDM
- b. pull tab
- c. IDSDM connector

The following table describes the IDSDM indicator codes:

Table 35. IDSDM indicator codes

Convention	IDSDM indicator code	Description
A	Green	Indicates that the card is online.
B	Flashing green	Indicates rebuild or activity.

Table 35. IDSDM indicator codes (continued)

Convention	IDSDM indicator code	Description
C	Flashing amber	Indicates card mismatch or that the card has failed.
D	Amber	Indicates that the card is offline, has failed, or is write protected.
E	Not lit	Indicates that the card is missing or is booting.

Next steps

1. Install the IDSDM.
2. If removed, install the SD cards.
3. Follow the procedure listed in the After working inside your system section.

Related references

[Safety instructions](#) on page 63

Related tasks

- [Before working inside your system](#) on page 64
- [Removing an internal SD card](#) on page 129
- [Installing the optional internal dual SD module](#) on page 132
- [Installing an internal SD card](#) on page 130
- [After working inside your system](#) on page 64

Installing the optional internal dual SD module

Prerequisites

 **CAUTION:** Many repairs may only be done by a certified service technician. You should only perform troubleshooting and simple repairs as authorized in your product documentation, or as directed by the online or telephone service and support team. Damage due to servicing that is not authorized by Dell is not covered by your warranty. Read and follow the safety instructions that are shipped with your product.

1. Follow the safety guidelines listed in the Safety instructions section.
2. Follow the procedure listed in the Before working inside your system section.
 -  **NOTE:** Temporarily label each SD card with its corresponding slot before removal.

Steps

1. Locate the internal dual SD module (IDSDM) connector on the system board. To locate the IDSDM connector, see the System board connectors section.
2. Align the IDSDM with the connector on the system board.
3. Push the IDSDM until it is firmly seated on the system board.

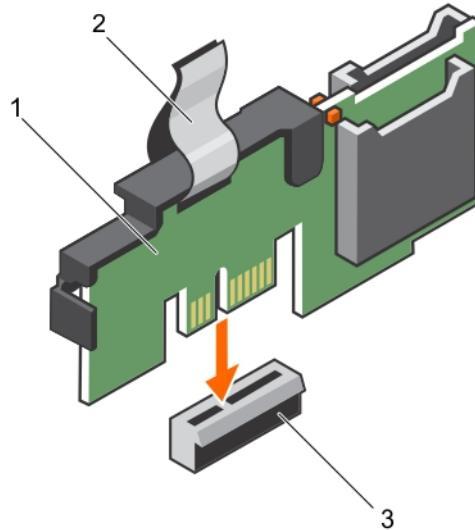

Figure 64. Installing the optional internal dual SD module

- a. IDSDM
- b. pull tab
- c. IDSDM connector

Next steps

1. Install the SD cards.
i **NOTE:** Re-install the SD cards into the same slots based on the labels you had marked on the cards during removal.
2. Follow the procedure listed in the After working inside your system section.

Related references

[Safety instructions](#) on page 63

Related tasks

[Before working inside your system](#) on page 64

[Installing an internal SD card](#) on page 130

[After working inside your system](#) on page 64

Network daughter card

The Network daughter card (NDC) is a small, removable mezzanine card. The NDC provides you with the flexibility of choosing different network connectivity options, for example—4 x 1GbE, 2 x 10GbE and 2 x Converged Network Adapter.

Removing the network daughter card

Prerequisites

1. Follow the safety guidelines listed in the Safety instructions section.
2. Follow the procedure listed in the Before working inside your system section.
3. If installed, remove the expansion card riser 1.
4. Keep the Phillips #1 screwdriver ready.

⚠ CAUTION: Many repairs may only be done by a certified service technician. You should only perform troubleshooting and simple repairs as authorized in your product documentation, or as directed by the online or

telephone service and support team. Damage due to servicing that is not authorized by Dell is not covered by your warranty. Read and follow the safety instructions that are shipped with your product.

Steps

1. Loosen the captive screws that secure the network daughter card (NDC) to the system board.
2. Hold the NDC by the edges on either side of the touch point, and lift the card to disengage it from the connector on the system board.
3. Slide the NDC away from the back of the system until the Ethernet connectors are clear of the slot in the back panel.
4. Lift the NDC out of the chassis.

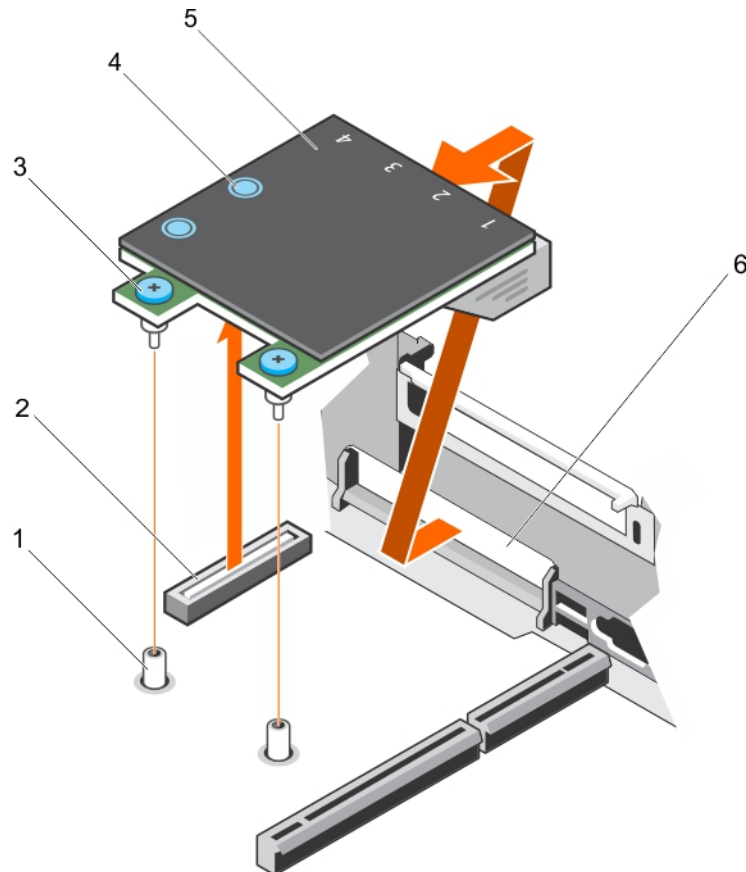

Figure 65. Removing the NDC

- | | |
|--------------------------------|--|
| 1. captive screw socket (2) | 2. connector on the system board |
| 3. captive screw (2) | 4. touch point (2) |
| 5. network daughter card (NDC) | 6. back panel slot for Ethernet connectors |

Next steps

1. Install the NDC.
2. If removed, install the expansion card riser 1.
3. Follow the procedure listed in the After working inside your system section.

Related references

[Safety instructions](#) on page 63

Related tasks

[Before working inside your system](#) on page 64

[Removing an expansion card from expansion card riser 1](#) on page 118

Installing the network daughter card on page 135

Removing an expansion card from expansion card riser 2 on page 121

After working inside your system on page 64

Installing the network daughter card

Prerequisites

1. Follow the safety guidelines listed in the Safety instructions section.
2. Follow the procedure listed in the Before working inside your system section.
3. If applicable, remove the expansion card riser 1.
4. Keep the Phillips #1 screwdriver ready.

CAUTION: Many repairs may only be done by a certified service technician. You should only perform troubleshooting and simple repairs as authorized in your product documentation, or as directed by the online or telephone service and support team. Damage due to servicing that is not authorized by Dell is not covered by your warranty. Read and follow the safety instructions that are shipped with your product.

Steps

1. Orient the network daughter card (NDC) so that the Ethernet connectors fit through the slot in the back panel.
2. Align the captive screws on the card with the captive screw sockets on the system board.
3. Press the touch points on the card until the card connector is firmly seated on the system board connector.
4. Tighten the captive screws to secure the NDC to the system board.

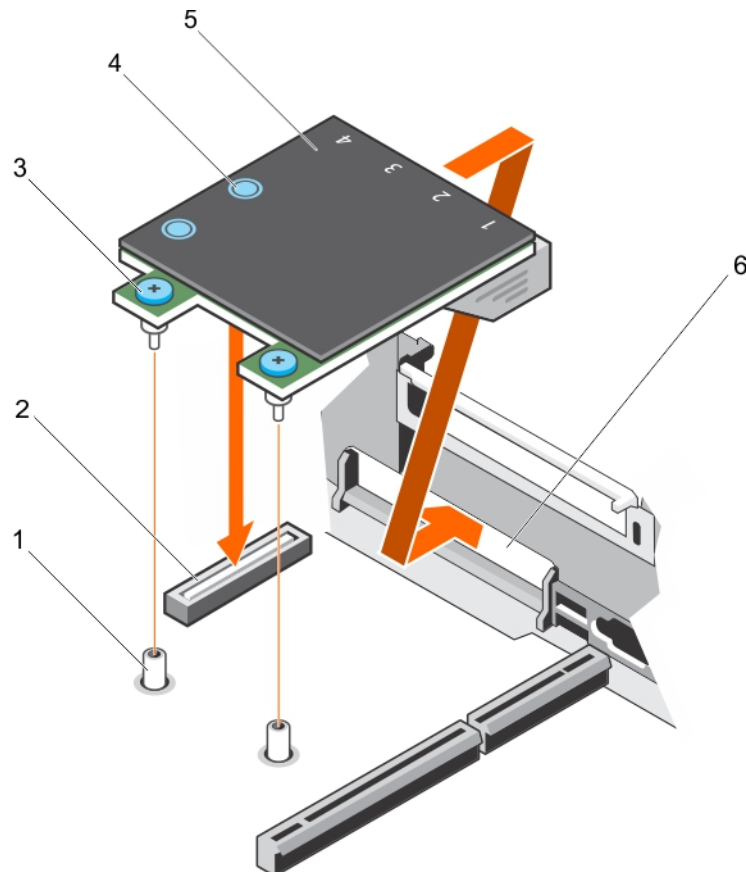

Figure 66. Installing the NDC

- | | |
|--------------------------------|--|
| 1. captive screw socket (2) | 2. connector on the system board |
| 3. captive screw (2) | 4. touch point (2) |
| 5. network daughter card (NDC) | 6. back panel slot for Ethernet connectors |

Next steps

1. Install the expansion card riser 1.
2. Follow the procedure listed in the After working inside your system section.

Related references

[Safety instructions](#) on page 63

Related tasks

[Before working inside your system](#) on page 64

[Removing an expansion card from expansion card riser 2](#) on page 121

[Installing an expansion card into expansion card riser 1](#) on page 120

[After working inside your system](#) on page 64

Internal USB memory key (optional)

An optional USB memory key installed inside your system can be used as a boot device, security key, or mass storage device.

To boot from the USB memory key, configure the USB memory key with a boot image and then specify the USB memory key in the boot sequence in System Setup.

The internal USB port must be enabled in **Internal USB Port** option in the **Integrated Devices** screen of **System Setup**.

i **NOTE:** To locate the internal USB port (INT_USB) on the system board, see the System board jumpers and connectors section.

Replacing the optional internal USB memory key

Prerequisites

1. Follow the safety guidelines listed in the Safety instructions section.
2. Follow the procedure listed in the Before working inside your system section.

Steps

1. Locate the USB port or USB memory key on the system board.
To locate the USB port, see the System board jumpers and connectors section.
2. If installed, remove the USB memory key from the USB port.

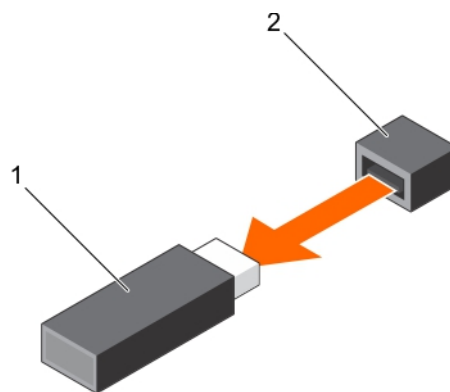

Figure 67. Removing the internal USB memory key

- a. USB memory key
 - b. USB port
3. Insert the replacement USB memory key into the USB port.

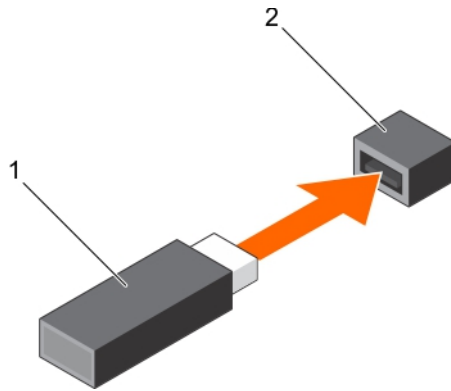

Figure 68. Installing the internal USB memory key

- a. USB memory key
- b. USB port

Next steps

1. Follow the procedure listed in the After working inside your system section.
2. While booting, press F2 to enter System Setup and verify that the system detects the USB memory key.

Related references

[Safety instructions](#) on page 63

Related tasks

[Before working inside your system](#) on page 64

[After working inside your system](#) on page 64

System battery

The system battery is used to power the real-time clock and storing the BIOS settings of the system.

Replacing the system battery

Prerequisites

NOTE: There is a danger of a new battery exploding if it is incorrectly installed. Replace the battery only with the same or equivalent type recommended by the manufacturer. For more information, see the safety information that shipped with your system.

CAUTION: Many repairs may only be done by a certified service technician. You should only perform troubleshooting and simple repairs as authorized in your product documentation, or as directed by the online or telephone service and support team. Damage due to servicing that is not authorized by Dell is not covered by your warranty. Read and follow the safety instructions that are shipped with your product.

1. Follow the safety guidelines listed in the Safety instructions section.
2. Follow the procedure listed in the Before working inside your system section.
3. Remove the cooling shroud.

Steps

1. Locate the battery socket. For more information, see the Jumpers and connectors section.

CAUTION: To avoid damage to the battery connector, you must firmly support the connector while installing or removing a battery.

2. Place your finger between the securing tabs at the negative side of the battery connector, and lift the battery out of the socket.

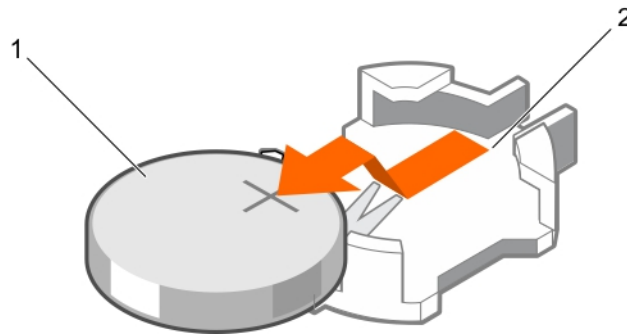

Figure 69. Removing the system battery

- a. system battery
- b. system battery slot

3. To install a new system battery, hold the battery with the "+" facing up and slide it under the securing tabs.
4. Press the battery into the connector until it snaps into place.

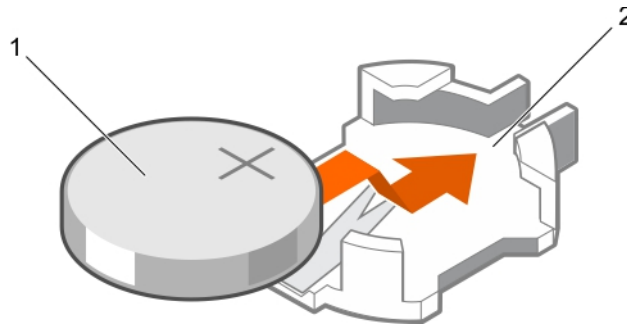

Figure 70. Installing the system battery

- a. system battery
- b. system battery slot

Next steps

1. Install the cooling shroud.
2. Follow the procedure listed in the After working inside your system section.
3. While booting, press F2 to enter System Setup and ensure the battery is operating properly.
4. Enter the correct time and date in the System Setup **Time** and **Date** fields.
5. Exit System Setup.

Related references

[Safety instructions](#) on page 63

Related tasks

[Before working inside your system](#) on page 64

[Removing the cooling shroud](#) on page 76

[Installing the cooling shroud](#) on page 77

[After working inside your system](#) on page 64

Hard drives

Your system supports entry hard drives and enterprise-class hard drives. Entry hard drives are designed for 5x8 operating environment with less workload rating to drives and enterprise-class drives are designed for 24x7 operating environment. Selecting the correct drive class will enable the critical areas of quality, functionality, performance, and reliability to be optimized for the target implementation.

 **NOTE:** Do not mix enterprise-class hard drives with entry hard drives.

Choosing the right drive type depends on the usage pattern. Improper use of entry hard drives (workload rating exceeds 55TB/year) will lead to significant risk and increase the drives failure rate.

For more information on these hard drives, see the *512e and 4Kn Disk Formats* whitepaper and *4K Sector HDD FAQ* document at [Dell.com/poweredgemanuals](https://Dell.com/poweredge manuals).

All hard drives are connected to the system board through the hard drive backplane. Hard drives are supplied in hot-swappable hard drive carriers that fit in the hard drive slots.

 **CAUTION:** Before attempting to remove or install a hard drive while the system is running, see the documentation for the storage controller card to ensure that the host adapter is configured correctly to support hot-swap hard drive removal and insertion.

 **CAUTION:** Do not turn off or restart your system while the hard drive is being formatted. Doing so can cause a hard drive failure.

Use only hard drives that have been tested and approved for use with the hard drive backplane.

When you format a hard drive, allow enough time for the formatting to be complete. Be aware that high-capacity hard drives can take a long time to format.

Removing a hot swappable hard drive or solid state drive

Prerequisites

 **CAUTION:** Many repairs may only be done by a certified service technician. You should only perform troubleshooting and simple repairs as authorized in your product documentation, or as directed by the online or telephone service and support team. Damage due to servicing that is not authorized by Dell is not covered by your warranty. Read and follow the safety instructions that came with the product.

1. Follow the safety guidelines listed in the Safety instructions section.
2. Follow the procedure listed in the Before working inside your system section.
3. If applicable, remove the bezel.
4. Using the management software, prepare the hard drive for removal. If the hard drive is online, the green activity or fault indicator flashes while the drive is turning off. When the hard drive indicators are off, the hard drive is ready for removal.

For more information, see the documentation for the storage controller.

 **CAUTION:** To prevent data loss, ensure that your operating system supports hot-swap drive installation. See the documentation supplied with your operating system.

Steps

1. Press the release button to open the hard drive or SSD carrier release handle.
2. Slide the hard drive or SSD carrier out of the hard drive slot.

 **CAUTION:** To maintain proper system cooling, all empty hard drive or SSD slots must have hard drive or SSD blanks installed.

3. If you are not replacing the hard drive or SSD immediately, insert a hard drive or SSD blank in the empty hard drive slot.

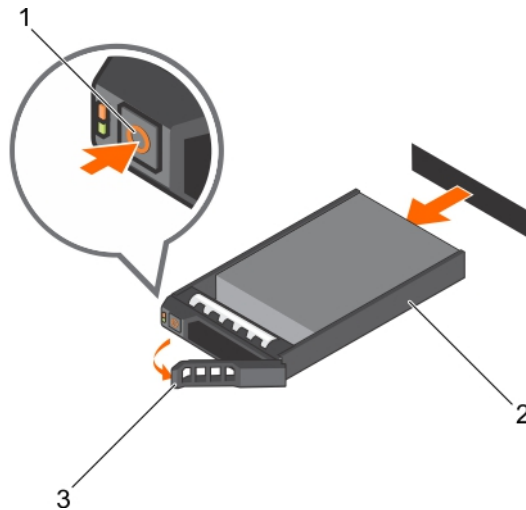

Figure 71. Removing a hot swappable hard drive or SSD

- a. release button
- b. hard drive or SSD carrier
- c. hard drive or SSD carrier handle

Related references

[Safety instructions](#) on page 63

Related tasks

[Before working inside your system](#) on page 64

[Removing the optional front bezel](#) on page 65

Installing a hot swappable hard drive or solid state drive

Prerequisites

- ⚠ **CAUTION:** Many repairs may only be done by a certified service technician. You should only perform troubleshooting and simple repairs as authorized in your product documentation, or as directed by the online or telephone service and support team. Damage due to servicing that is not authorized by Dell is not covered by your warranty. Read and follow the safety instructions that are shipped with your product.
- ⚠ **CAUTION:** Use only hard drives that have been tested and approved for use with the hard drive backplane.
- ⚠ **CAUTION:** When installing a hard drive, ensure that the adjacent drives are fully installed. Inserting a hard drive carrier and attempting to lock its handle next to a partially installed carrier can damage the partially installed carrier's shield spring and make it unusable.
- ⚠ **CAUTION:** To prevent data loss, ensure that your operating system supports hot-swap drive installation. See the documentation supplied with your operating system.
- ⚠ **CAUTION:** When a replacement hot swappable drive is installed and the system is powered on, the drive automatically begins to rebuild. Ensure that the replacement drive is blank or contains data that you wish to overwrite. Any data on the replacement drive is immediately lost after the drive is installed.

Steps

1. If a hard drive blank is installed in the hard drive slot, remove it.
2. Install a hard drive in the hard drive carrier.
3. Press the release button on the front of the hard drive carrier and open the hard drive carrier handle.
4. Insert the hard drive carrier into the hard drive slot until the carrier connects with the backplane.

5. Close the hard drive carrier handle to lock the hard drive in place.

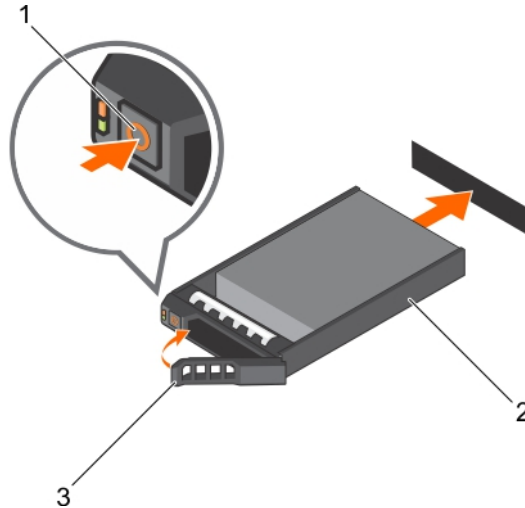

Figure 72. Installing a hot-swappable hard drive or SSD

- a. release button
- b. hard drive or SSD carrier
- c. hard drive or SSD carrier handle

Related references

[Safety instructions](#) on page 63

Related tasks

[Removing a hot swappable hard drive or solid state drive](#) on page 139

[Installing a hard drive or solid state drives into a hard drive carrier](#) on page 143

Removing a 2.5-inch hard drive blank

Prerequisites

CAUTION: Many repairs may only be done by a certified service technician. Perform troubleshooting and simple repairs as authorized in your product documentation, or as directed by the online or telephone service and support team. Damage due to servicing that is not authorized by Dell is not covered by your warranty. Read and follow the safety instructions that came with the product.

CAUTION: To maintain proper system cooling, all empty hard drive slots must have hard drive blanks installed.

1. Follow the safety guidelines listed in the Safety instructions section.
2. If installed, remove the bezel.

Steps

Press the release button and slide the hard drive blank out of the hard drive slot.

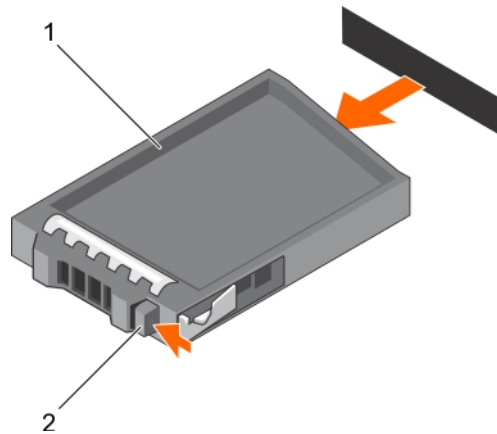

Figure 73. Removing a 2.5-inch hard drive blank

- a. hard drive blank
- b. release button

Related references

[Safety instructions](#) on page 63

Related tasks

[Removing the optional front bezel](#) on page 65

[Installing a 2.5-inch hard drive blank](#) on page 142

Installing a 2.5-inch hard drive blank

Prerequisites

1. Follow the safety guidelines listed in the Safety instructions section.
2. If installed, remove the front bezel.

Steps

Insert the hard drive blank into the hard drive slot until the release button clicks into place.

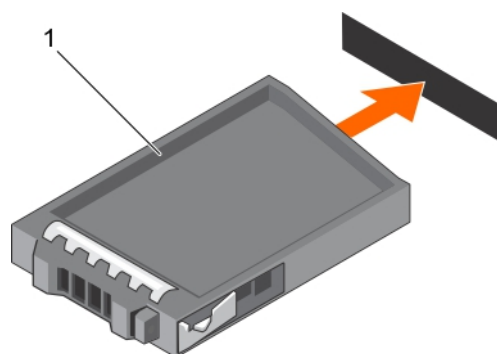

Figure 74. Installing a 2.5-inch hard drive blank

- a. hard drive blank

Next steps

If removed, install the front bezel.

Related references

[Safety instructions](#) on page 63

Related tasks

[Removing the optional front bezel](#) on page 65

[Installing the optional front bezel](#) on page 66

[Removing a 2.5-inch hard drive blank](#) on page 141

Removing a hard drive or a solid state drive from a hard drive carrier

Prerequisites

1. Keep the Phillips #1 screwdriver ready.
2. Remove the hot swappable hard drive carrier from the system.

Steps

1. Remove the screws from the slide rails on the hard drive carrier.
2. Lift the hard drive out of the hard drive carrier.

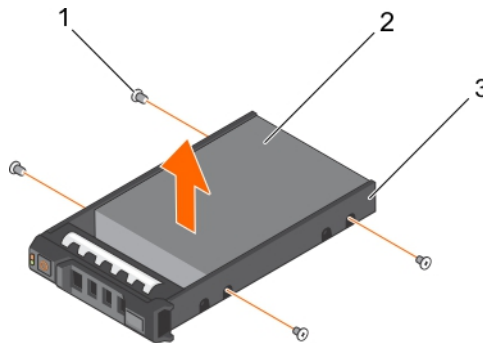

Figure 75. Removing a hard drive from a hard drive carrier

- a. screw (4)
- b. hard drive
- c. hard drive carrier

Next steps

If applicable, install a hard drive into the hard drive carrier.

Related references

[Safety instructions](#) on page 63

Related tasks

[Installing a hard drive or solid state drives into a hard drive carrier](#) on page 143

Installing a hard drive or solid state drives into a hard drive carrier

Prerequisites

Steps

1. Insert the hard drive into the hard drive carrier with the connector end of the hard drive toward the back of the carrier.
2. Align the screw holes on the hard drive with the screws holes on the hard drive carrier.
When aligned correctly, the back of the hard drive is flush with the back of the hard drive carrier.
3. Attach the screws to secure the hard drive to the hard drive carrier.

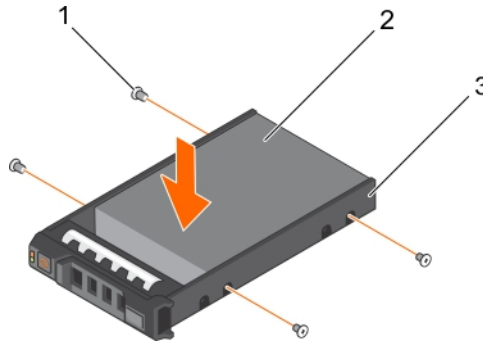

Figure 76. Installing a hard drive into a hard drive carrier

- a. screw (4)
- b. hard drive
- c. hard drive carrier

Next steps

Install the hot swappable hard drive carrier.

Related references

[Safety instructions](#) on page 63

Optical drive (optional)

Optical drives retrieve and store data on optical discs such as CD and DVD. Optical drives can be categorized into two basic types: optical disc readers and optical disc writers.

Removing the optical drive

Prerequisites

CAUTION: Many repairs may only be done by a certified service technician. You should only perform troubleshooting and simple repairs as authorized in your product documentation, or as directed by the online or telephone service and support team. Damage due to servicing that is not authorized by Dell is not covered by your warranty. Read and follow the safety instructions that are shipped with your product.

1. Follow the safety guidelines listed in the Safety instructions section.
2. Follow the procedure listed in the Before working inside your system section.

Steps

1. Disconnect the power and data cables from the back of the drive.

NOTE: Ensure that you note the routing of the power and data cable on the side of the system as you remove them from the system board and drive. Route these cables properly when you replace them to prevent them from being pinched or crimped.

2. To release the optical drive, press the release tab.
3. Slide the optical drive out of the system until it is free of the optical drive slot.
4. If you are not adding a new optical drive, install the optical drive blank. The procedure to install the optical drive blank is the same as the optical drive.

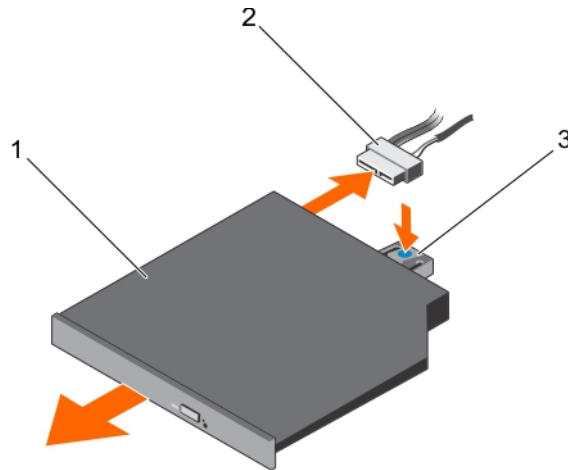

Figure 77. Removing the optional optical drive

- a. optical drive
- b. power and data cable
- c. release tab

Next steps

Follow the procedure listed in the After working inside your system section.

Related references

[Safety instructions](#) on page 63

Related tasks

[Before working inside your system](#) on page 64

[Installing the slim optical drive blank](#) on page 147

[After working inside your system](#) on page 64

Installing the optical drive

Prerequisites

CAUTION: Many repairs may only be done by a certified service technician. You should only perform troubleshooting and simple repairs as authorized in your product documentation, or as directed by the online or telephone service and support team. Damage due to servicing that is not authorized by Dell is not covered by your warranty. Read and follow the safety instructions that are shipped with your product.

1. Follow the safety guidelines listed in the Safety instructions section.
2. Follow the procedure listed in the Before working inside your system section.
3. If installed, remove the optical drive blank.

Steps

1. Align the optical drive with the optical drive slot on the front of the chassis.
2. Slide in the optical drive until the release tab snaps into place.
3. Connect the power and data cable to the optical drive and system board.

NOTE: Route the cable properly on the side of the system to prevent it from being pinched or crimped.

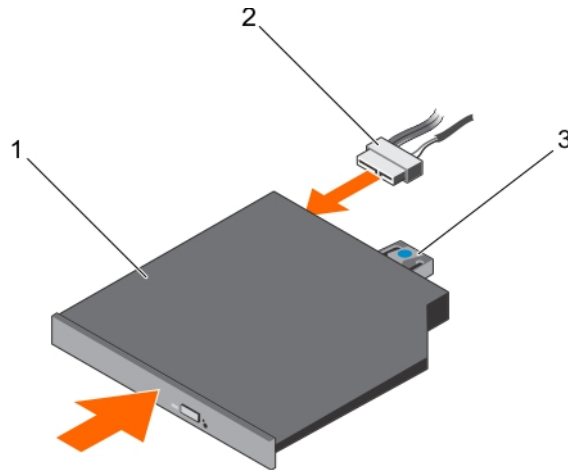

Figure 78. Installing the optional optical drive

- a. optical drive
- b. power and data cable
- c. release tab

Next steps

Follow the procedure listed in the After working inside your system section.

Related references

[Safety instructions](#) on page 63

Related tasks

[Before working inside your system](#) on page 64

[After working inside your system](#) on page 64

Removing the slim optical drive blank

Prerequisites

CAUTION: Many repairs may only be done by a certified service technician. You should only perform troubleshooting and simple repairs as authorized in your product documentation, or as directed by the online or telephone service and support team. Damage due to servicing that is not authorized by Dell is not covered by your warranty. Read and follow the safety instructions that are shipped with your product.

1. Follow the safety guidelines listed in the Safety instructions section.
2. Follow the procedure listed in the Before working inside your system section.

Steps

1. Locate the touch point for the slim optical drive blank lock inside the system.
2. Press the lock and pull the slim optical drive blank out of the chassis.

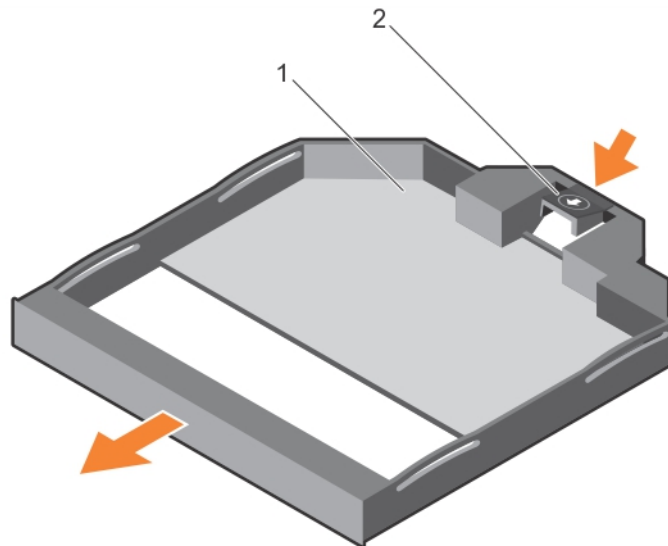

Figure 79. Removing the slim optical drive blank

- a. slim optical drive blank
- b. optical drive blank lock

Related references

[Safety instructions](#) on page 63

Related tasks

[Before working inside your system](#) on page 64

Installing the slim optical drive blank

Prerequisites

CAUTION: Many repairs may only be done by a certified service technician. You should only perform troubleshooting and simple repairs as authorized in your product documentation, or as directed by the online or telephone service and support team. Damage due to servicing that is not authorized by Dell is not covered by your warranty. Read and follow the safety instructions that are shipped with your product.

1. Follow the safety instructions listed in the Safety instructions section.
2. Follow the procedure listed in the Before working inside your system section.

Steps

1. Align the slim optical drive blank with the slim optical drive bay.
2. Slide the optical drive blank into the optical drive bay until the lock clicks into place.

Next steps

Follow the procedure listed in the After working inside your system section.

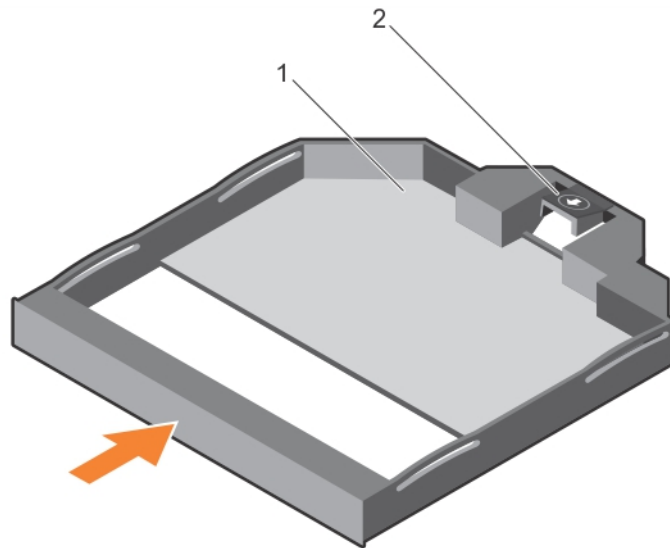

Figure 80. Installing the slim optical drive blank

1. slim optical drive blank
2. optical drive blank lock

Related references

[Safety instructions](#) on page 63

Related tasks

[After working inside your system](#) on page 64

Hard drive backplane

Your system supports:

- 2.5 inch (x16) SAS/SATA backplane or
- 2.5 inch (x8) SAS/SATA backplane

Removing the hard drive backplane

Prerequisites

1. Follow the safety guidelines listed in the Safety instructions section.
2. Follow the procedure listed in the Before working inside your system section.
3. Remove the cooling shroud.
4. Remove the cooling fan assembly.
5. Remove all hard drives.

CAUTION: Many repairs may only be done by a certified service technician. You should only perform troubleshooting and simple repairs as authorized in your product documentation, or as directed by the online or telephone service and support team. Damage due to servicing that is not authorized by Dell is not covered by your warranty. Read and follow the safety instructions that are shipped with your product.

CAUTION: To prevent damage to the drives and backplane, remove the hard drives from the system before removing the backplane.

CAUTION: Note the number of each hard drive and temporarily label them before you remove the hard drive so that you can replace them in the same locations.

Steps

1. Disconnect the SAS/SATA data, signal, and power cable(s) from the backplane.
2. Press the release tabs and lift the backplane upward and slide it toward the back of the chassis.

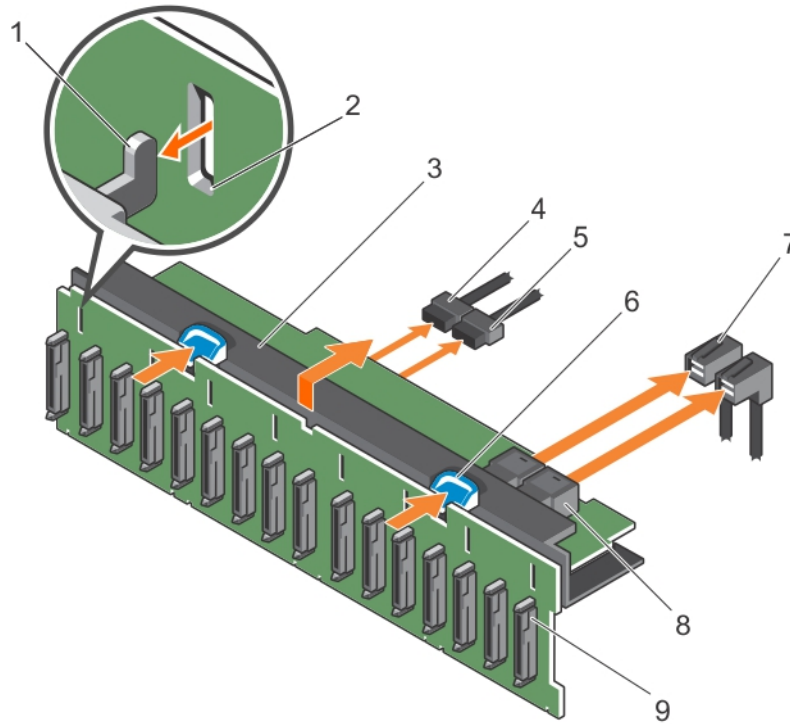

Figure 81. Removing the 2.5 inch (x16) SAS/SATA backplane

- | | |
|--|---------------------------|
| 1. hooks (3) | 2. securing slots (3) |
| 3. hard drive backplane | 4. backplane power cable |
| 5. backplane signal cable | 6. release tab (2) |
| 7. SAS cable (2) | 8. mini SAS connector (2) |
| 9. hard drive connector on the backplane | |

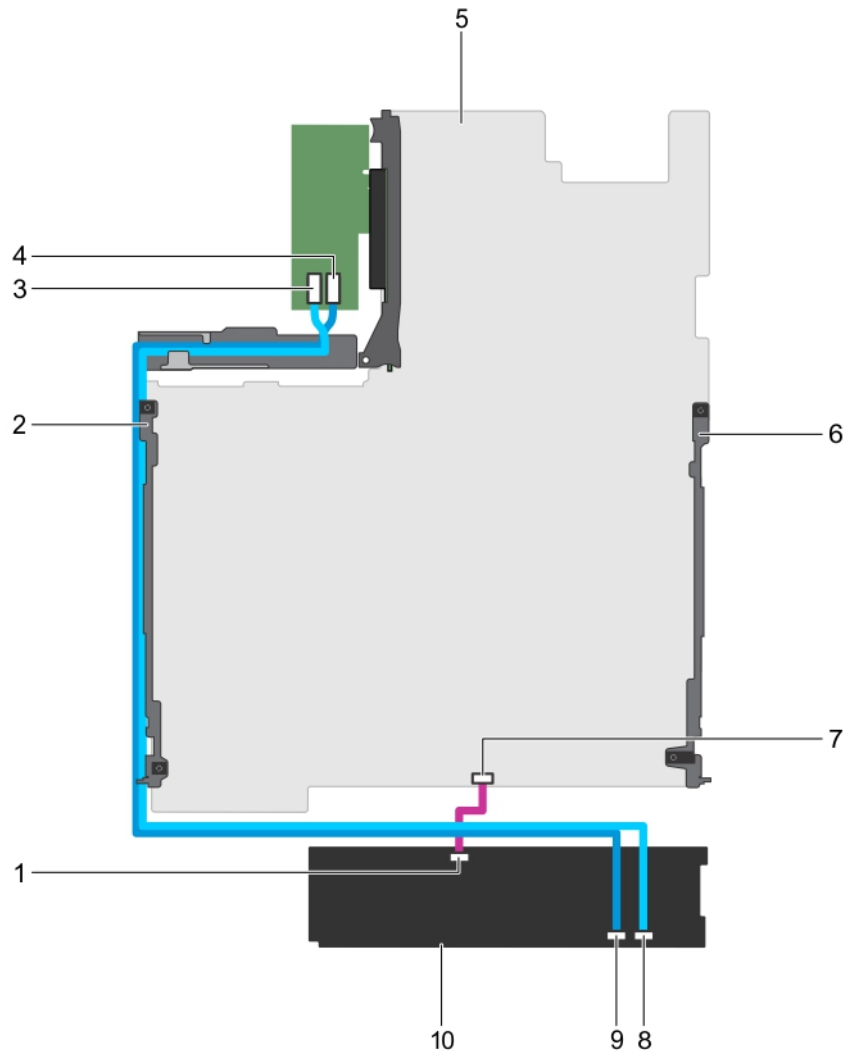

Figure 82. Cabling diagram—2.5 inch (x16) SAS/SATA backplane

- | | |
|---|-------------------------------------|
| 1. signal connector on the backplane | 2. cable retention bracket |
| 3. SAS B connector on the PERC card | 4. SAS A connector on the PERC card |
| 5. system board | 6. cable retention bracket |
| 7. signal connector on the system board | 8. SAS B connector on the backplane |
| 9. SAS A connector on the backplane | 10. hard drive backplane |

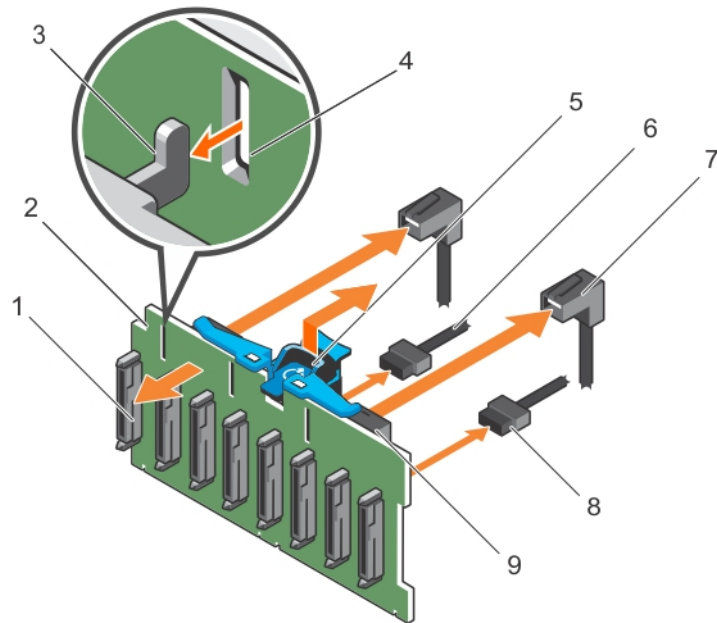

Figure 83. Removing the 2.5 inch (x8) SAS/SATA backplane

- | | |
|--|---------------------------|
| 1. hard drive connector on the backplane | 2. hard drive backplane |
| 3. hooks (3) | 4. securing slots (3) |
| 5. release tab | 6. backplane power cable |
| 7. SAS cable (2) | 8. backplane signal cable |
| 9. mini SAS connector (2) | |

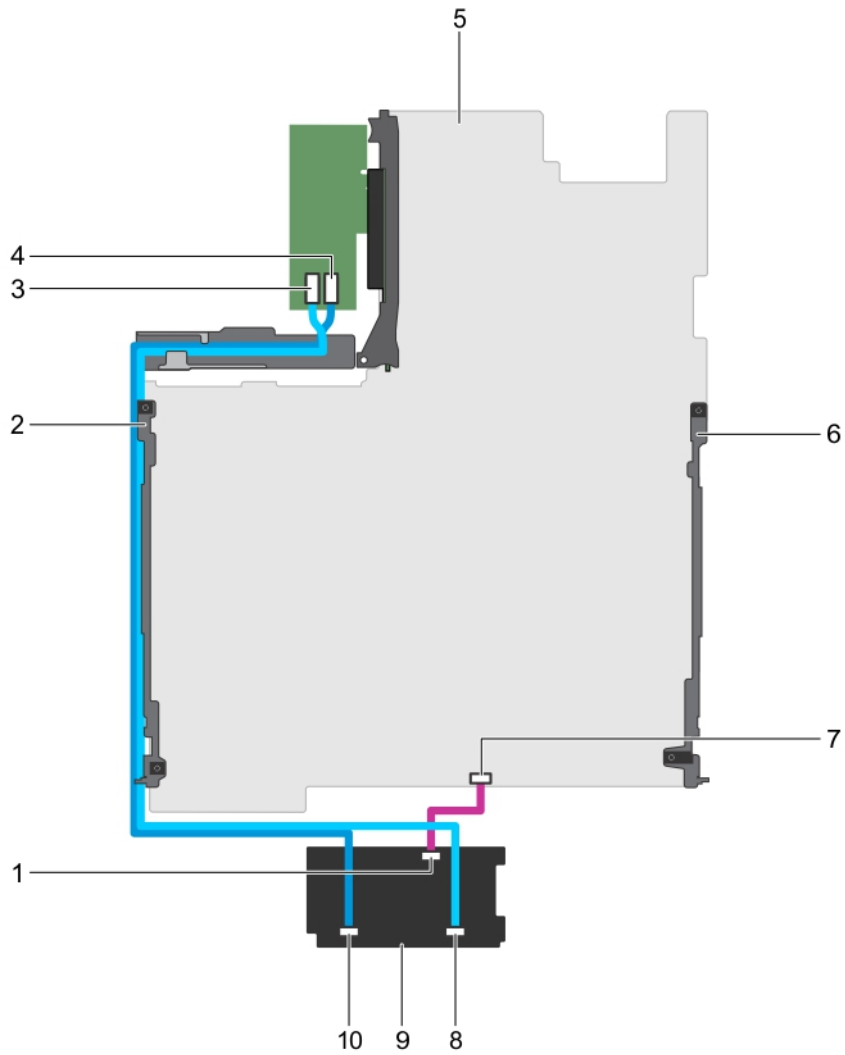

Figure 84. Cabling diagram—2.5 inch (x8) SAS/SATA backplane

- | | |
|---|--------------------------------------|
| 1. signal connector on the backplane | 2. cable retention bracket |
| 3. SAS B connector on the PERC card | 4. SAS A connector on the PERC card |
| 5. system board | 6. cable retention bracket |
| 7. signal connector on the system board | 8. SAS B connector on the backplane |
| 9. hard drive backplane | 10. SAS A connector on the backplane |

Next steps

1. Replace the hard drive backplane.
2. Install the cooling fan assembly.
3. Install the cooling shroud.
4. Install all the hard drives.
5. Follow the procedure listed in the After working inside your system section.

Related references

[Safety instructions](#) on page 63

Related tasks

- [Before working inside your system](#) on page 64
- [Removing the cooling shroud](#) on page 76
- [Removing the cooling fan assembly](#) on page 80

Installing the hard drive backplane

Prerequisites

1. Follow the safety guidelines listed in the Safety instructions section.
2. Follow the procedure listed in the Before working inside your system section.

CAUTION: Many repairs may only be done by a certified service technician. You should only perform troubleshooting and simple repairs as authorized in your product documentation, or as directed by the online or telephone service and support team. Damage due to servicing that is not authorized by Dell is not covered by your warranty. Read and follow the safety instructions that are shipped with your product.

Steps

1. Connect the SAS/SATA/SSD data, signal, and power cables to the backplane.
2. Use the hooks on the chassis as guides to align the hard drive backplane.
3. Lower the hard drive backplane until the release tabs snap into place.

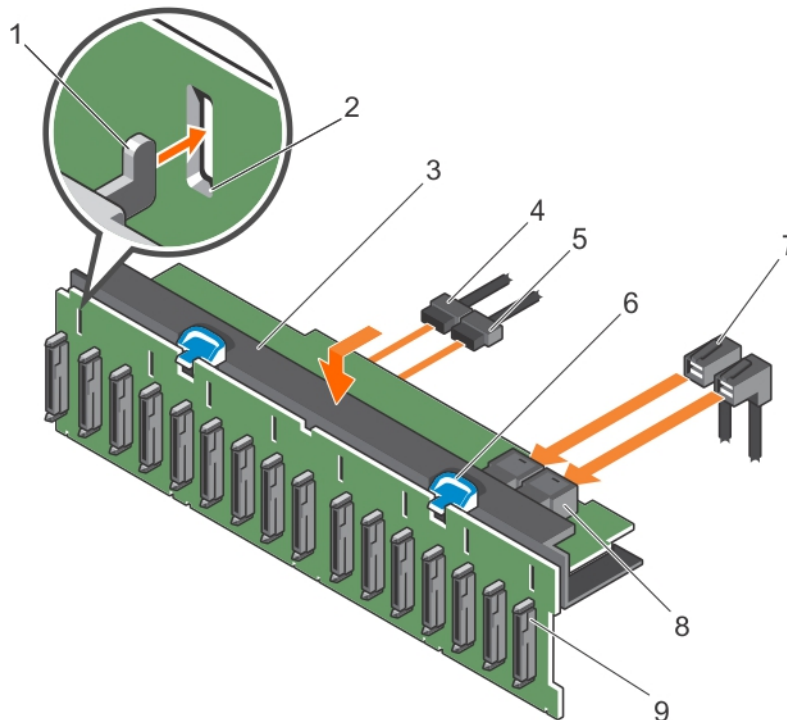

Figure 85. Installing the 2.5 inch (x16) SAS/SATA backplane

- | | |
|--|---------------------------|
| 1. hooks (3) | 2. securing slots (3) |
| 3. hard drive backplane | 4. backplane power cable |
| 5. backplane signal cable | 6. release tab (2) |
| 7. SAS cable (2) | 8. mini SAS connector (2) |
| 9. hard drive connector on the backplane | |

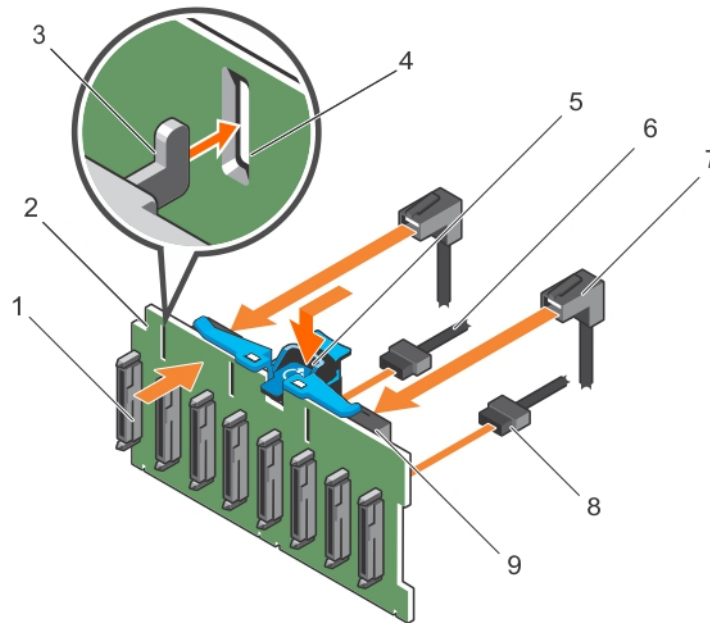

Figure 86. Installing the 2.5 inch (x8) SAS/SATA backplane

- | | |
|--|---------------------------|
| 1. hard drive connector on the backplane | 2. hard drive backplane |
| 3. hooks (3) | 4. securing slots (3) |
| 5. release tab | 6. backplane power cable |
| 7. SAS cable (2) | 8. backplane signal cable |
| 9. mini SAS connector (2) | |

Next steps

1. Install the hard drives in their original locations.
2. Follow the procedure listed in the After working inside your system section.

Related references

[Safety instructions](#) on page 63

Related tasks

[Before working inside your system](#) on page 64

[Hard drives](#) on page 139

[After working inside your system](#) on page 64

Control panel

The control panel contains the power button, the diagnostic indicators, and the front USB ports.

Removing the control panel

Prerequisites

1. Follow the safety guidelines listed in safety instructions section.
2. Follow the procedure listed in the Before working inside your system section.
3. Keep the Phillips #2 screwdriver handy.

CAUTION: Many repairs may only be done by a certified service technician. You should only perform troubleshooting and simple repairs as authorized in your product documentation, or as directed by the online or telephone service and support team. Damage due to servicing that is not authorized by Dell is not covered by your warranty. Read and follow the safety instructions that are shipped with your product.

Steps

1. Using a Phillips #2 screwdriver, remove the screw(s) securing the control panel to the chassis.

CAUTION: Do not use excessive force when removing the control panel as it can damage the connectors.

2. Remove all the cables connecting the control panel to the system board.

NOTE: Ensure that you remove the cooling fan assembly before you remove the USB power cable.

3. From inside the system, push the control panel out of the chassis.

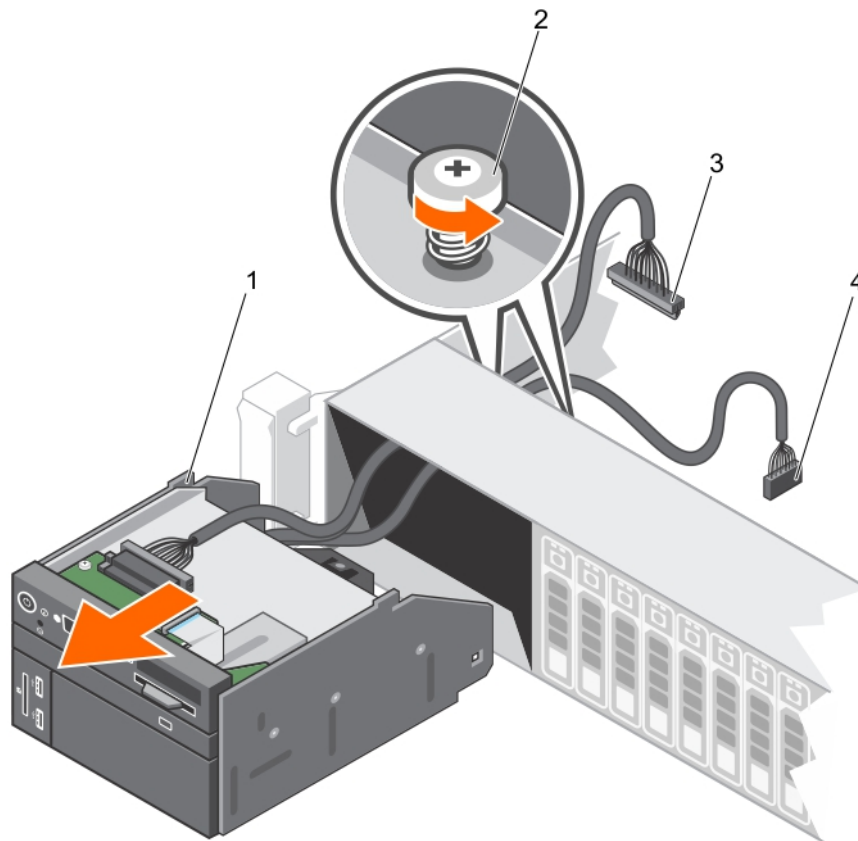

Figure 87. Removing the control panel

1. control panel
 2. screw (2)
 3. control panel connector cable
 4. USB connector cable
4. You can remove the vFlash connector/USB connector module from the control panel using the following steps:
 - a. Disconnect the control panel cable from the control panel.
 - b. Remove the screws that attach the vFlash connector/USB connector module to the control panel.
 - c. Pull the vFlash connector/USB connector module to disengage from the control panel module.

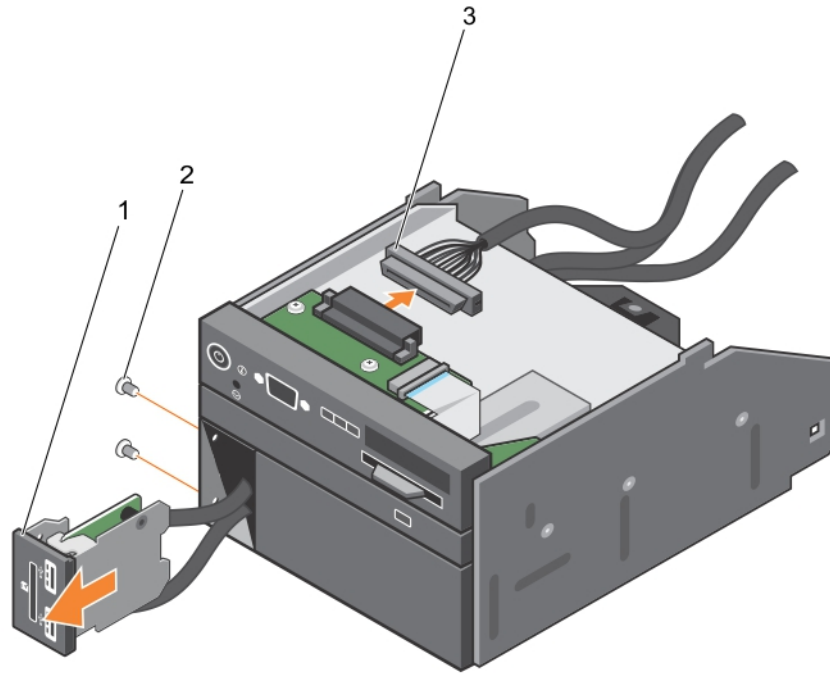

Figure 88. Removing the vFlash connector/USB connector module

- i. vFlash connector/USB connector module
- ii. screw (2)
- iii. control panel connector cable

5. Locate and press the tabs on the information tag.
6. Push the information tag out of the slot to remove it from the control panel.

NOTE: Retain the information tag for replacement in the new control panel.

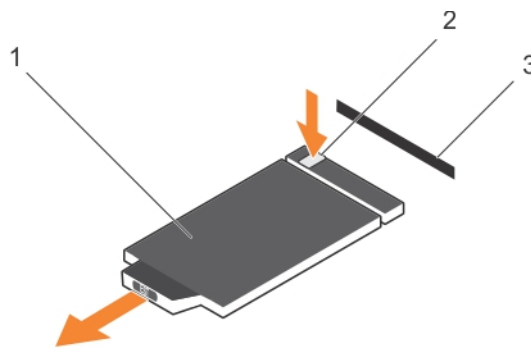

Figure 89. Removing the information tag

- a. information tag
- b. tab
- c. slot

Next steps

1. Replace the vFlash connector/USB connector module.
2. Replace the control panel.
3. Follow the procedure listed in the After working inside your system section.

Related references

[Safety instructions](#) on page 63

Related tasks

[Before working inside your system](#) on page 64

[Installing the control panel](#) on page 157

[After working inside your system](#) on page 64

Installing the control panel

Prerequisites

1. Follow the safety guidelines listed in the Safety instructions section.
2. Follow the procedure listed in the Before working inside your system section.
3. Keep the #2 Phillips screwdriver ready.

CAUTION: Many repairs may only be done by a certified service technician. You should only perform troubleshooting and simple repairs as authorized in your product documentation, or as directed by the online or telephone service and support team. Damage due to servicing that is not authorized by Dell is not covered by your warranty. Read and follow the safety instructions that are shipped with your product.

Steps

1. Replace the blank information tag in the new control panel with the information tag retained from the old control panel.

NOTE: Information tag lists system information such as Service Tag, NIC, and MAC address.

2. If disengaged, install the vFlash connector/USB connector module into the control panel using the following steps:
 - a. Connect the control panel cable to the control panel.
 - b. Install the screws to attach the vFlash connector/USB connector module to the control panel.

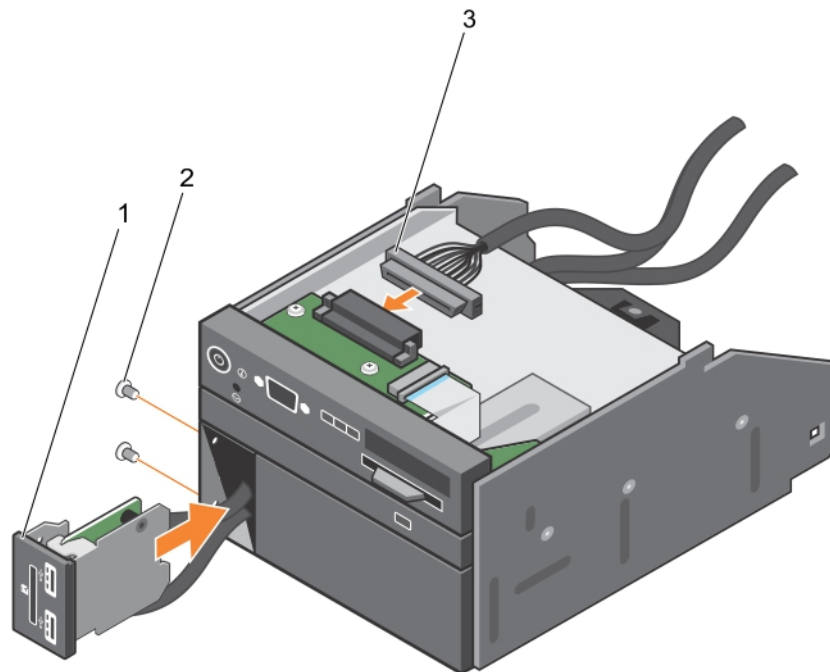

Figure 90. Installing the vFlash connector/USB connector module

- i. vFlash connector/USB connector module
 - ii. screw (2)
 - iii. control panel connector cable
3. To install the information tag, push the information tag into the control panel slot.
 4. Connect all the applicable cables to the system board.

NOTE: Ensure that you remove the cooling fan assembly before install the USB power cable.

5. Slide the control panel into the slot in the chassis and secure the module with the screws.

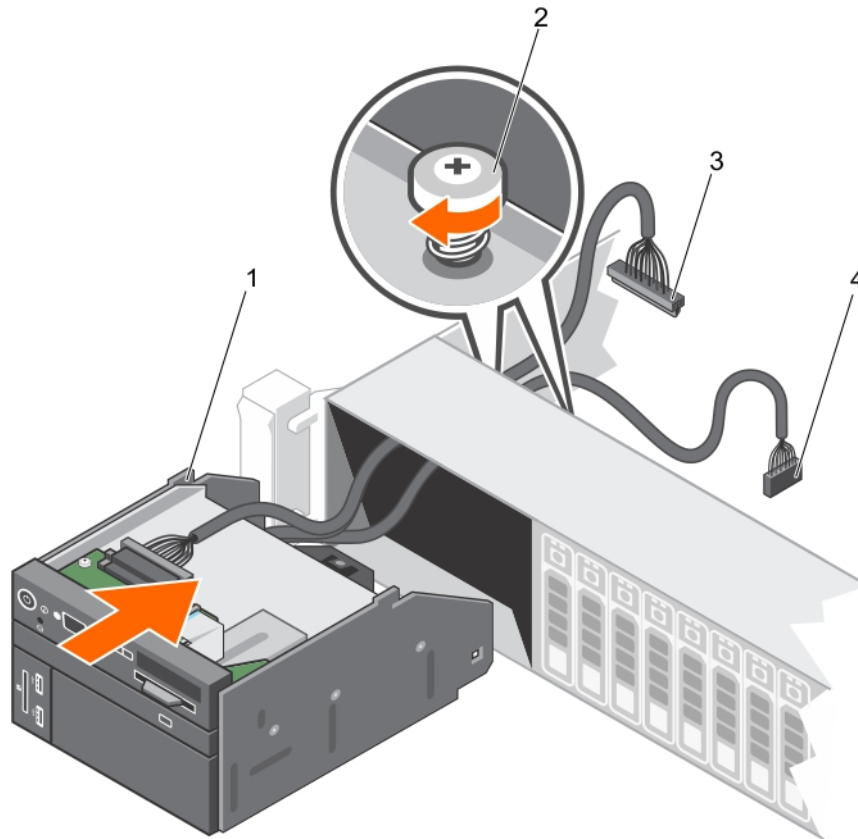

Figure 91. Installing the control panel

- 1. control panel
- 2. screw (2)
- 3. control panel connector cable
- 4. USB connector cable

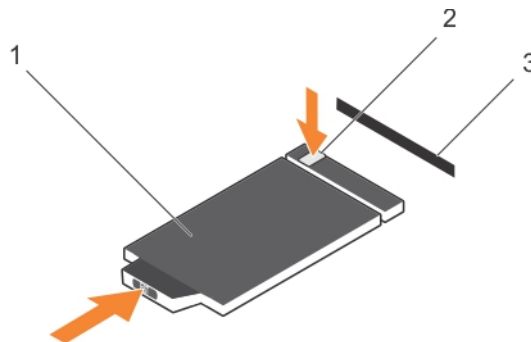

Figure 92. Installing the information tag

- a. information tag
- b. tab
- c. slot

Next steps

Follow the procedure listed in the After working inside your system section

Related references

[Safety instructions](#) on page 63

Related tasks

[Before working inside your system](#) on page 64



[After working inside your system](#) on page 64

System board

A system board (also known as the motherboard) is the main printed circuit board in the system with different connectors used to connect different components or peripherals of the system. A system board provides the electrical connections to the components in the system to communicate.



Removing the system board

Prerequisites

-  **CAUTION:** Many repairs may only be done by a certified service technician. You should only perform troubleshooting and simple repairs as authorized in your product documentation, or as directed by the online or telephone service and support team. Damage due to servicing that is not authorized by Dell is not covered by your warranty. Read and follow the safety instructions that are shipped with your product.
-  **CAUTION:** If you are using the Trusted Platform Module (TPM) with an encryption key, you may be prompted to create a recovery key during program or System Setup. Be sure to create and safely store this recovery key. If you replace this system board, you must supply the recovery key when you restart your system or program before you can access the encrypted data on your hard drives.
-  **CAUTION:** Do not attempt to remove the TPM plug-in module from the system board. Once the TPM plug-in module is installed, it is cryptographically bound to that specific system board. Any attempt to remove an installed TPM plug-in module breaks the cryptographic binding, and it cannot be re-installed or installed on another system board.

1. Follow the safety guidelines listed in the Safety instructions section.
2. Follow the procedure listed in the Before working inside your system section.
3. Remove the following components:
 - a. Processor expansion module, if installed
 - b. Cooling shroud, if installed.
 - c. Cooling fan assembly.
 - d. Power supply units
 - e. All expansion card risers
 - f. Integrated storage controller card
 - g. Internal dual SD module
 - h. Internal USB key, if installed.
 - i. PCIe card holder
 - j. Heat sinks or heat sink blanks
 - k. Processors or processor blanks
 -  **CAUTION:** To prevent damage to the processor pins when replacing a faulty system board, ensure that you cover the processor socket with the processor protective cap.
 - l. Memory modules and memory module blanks
 - m. Network daughter card

Steps

1. Disconnect all cables from the system board.
 -  **CAUTION:** Take care not to damage the system identification button while removing the system board from the chassis.
 -  **CAUTION:** Do not lift the system board by holding a memory module, processor, or other components.

2. Hold the system board holder, lift the blue release pin, lift the system board, and then slide it toward the front of the chassis. Sliding the system board toward the front of the chassis disengages the connectors from the back of the chassis slots.
3. Lift the system board out of the chassis.

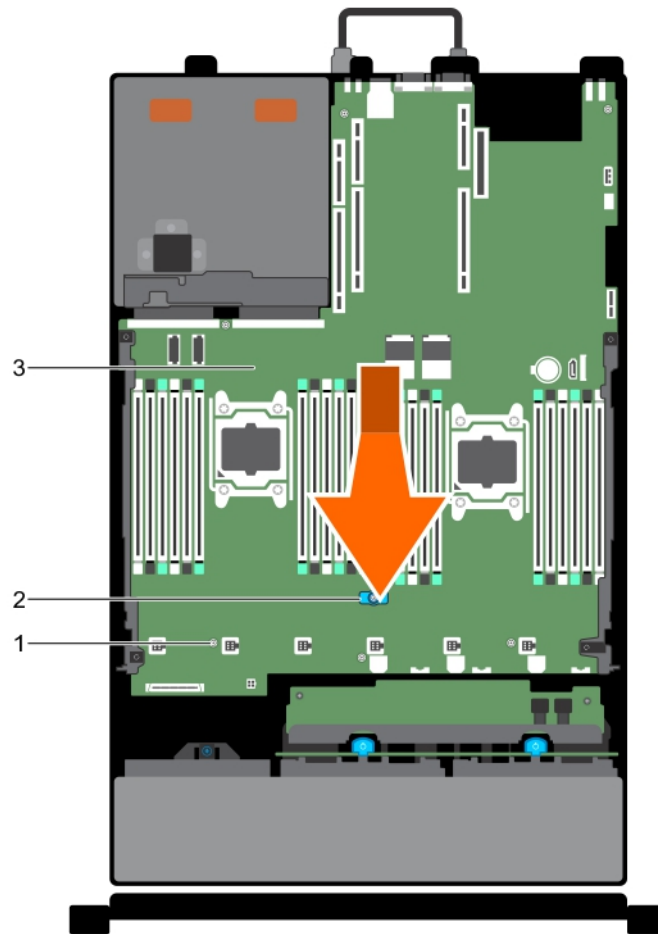

Figure 93. Removing the system board

- a. thumb screw
- b. system board holder
- c. system board

Next steps

1. Install the system board.
2. Follow the procedure listed in the After working inside your system section.

Related references

[Safety instructions](#) on page 63

Related tasks

[Before working inside your system](#) on page 64

[Installing the system board](#) on page 161

[After working inside your system](#) on page 64

Installing the system board

Prerequisites

1. Follow the safety guidelines listed in the Safety instructions section.
2. Follow the procedure listed in the Before working inside your system section.

CAUTION: Many repairs may only be done by a certified service technician. You should only perform troubleshooting and simple repairs as authorized in your product documentation, or as directed by the online or telephone service and support team. Damage due to servicing that is not authorized by Dell is not covered by your warranty. Read and follow the safety instructions that are shipped with your product.

Steps

1. Unpack the new system board assembly.

CAUTION: Do not lift the system board by holding a memory module, processor, or other components.

CAUTION: Take care not to damage the system identification button while placing the system board into the chassis.

2. Hold the touch points and lower the system board into the chassis.
3. Push the system board toward the back of the chassis until the board clicks into place.

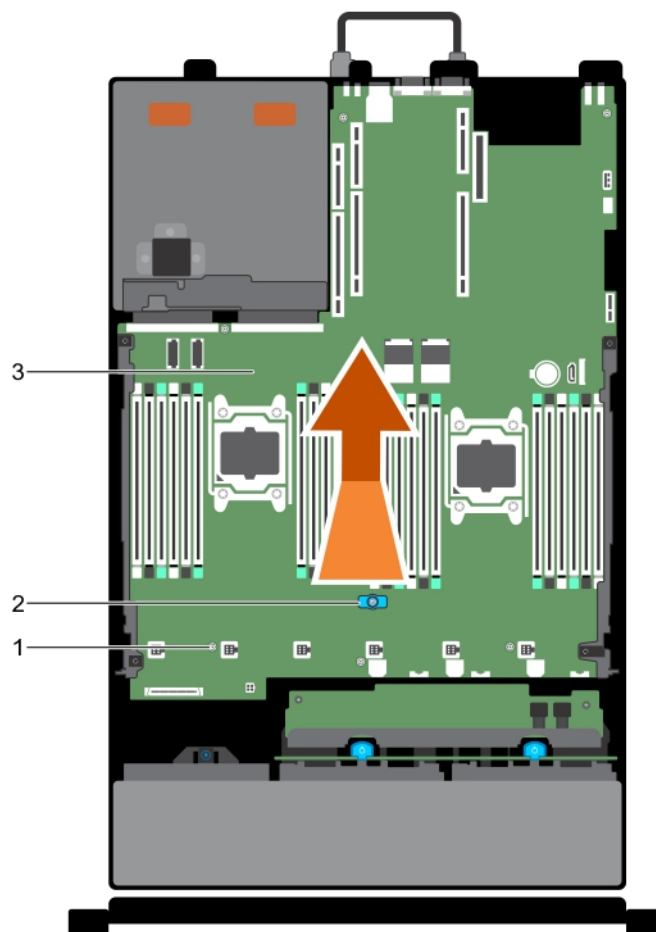

Figure 94. Removing the system board

- a. thumb screw
- b. system board holder

- c. system board

Next steps

1. Install the Trusted Platform Module (TPM). For information about how to install the TPM, see the Installing the Trusted Platform Module section.
 - i** **NOTE:** The TPM plug-in module is attached to the system board and cannot be removed. A replacement TPM plug-in module will be provided for all system board replacements where a TPM plug-in module was installed.
2. Replace the following components:
 - a. Cable retention bracket
 - b. PCIe card holder
 - c. Integrated storage controller card
 - d. Internal USB key, if applicable
 - e. Internal dual SD module
 - f. All expansion card risers
 - g. Heat sinks or heat sink blanks
 - h. Processors or processor blank
 - i. Memory modules and memory module blanks
 - j. Network daughter card
 - k. Cooling fan assembly
 - l. Cooling shroud, if installed.
 - m. Power supply unit
 - n. Processor expansion module (if applicable)
3. Reconnect all cables to the system board.
 - i** **NOTE:** Ensure that the cables inside the system are routed along the chassis wall and secured using the cable securing bracket.
4. Follow the procedure listed in the After working inside your system section.
5. Ensure that you:
 - a. Use the Easy Restore feature to restore the Service Tag, iDRAC license, BIOS settings, onboard diagnostics, and optional personality or ID modules. For more information, see the Easy restore section. If Easy Restore does not execute for any reason you must:
 - i. Enter the system Service Tag manually. For more information, see the Entering the system Service Tag section.
 - ii. Import your new or existing iDRAC Enterprise license. For more information, see Integrated Dell Remote Access Controller User's Guide, at <https://www.dell.com/esmmanuals>.
 - b. Update the BIOS and iDRAC versions.
 - c. Re-enable the Trusted Platform Module (TPM). For more information, see the Re-enabling the Trusted Platform Module (TPM) section.

Related references

[Safety instructions](#) on page 63

Related tasks

[Before working inside your system](#) on page 64

[Removing the system board](#) on page 159

[Restoring the Service Tag by using the Easy Restore feature](#) on page 163

[Entering the system Service Tag by using System Setup](#) on page 163

[Initializing the TPM for TXT users](#) on page 165

[After working inside your system](#) on page 64

Entering the system Service Tag by using System Setup

If Easy Restore fails to restore the Service Tag, use System Setup to enter the Service Tag.

Steps

1. Turn on the system.
2. Press F2 to enter System Setup.
3. Click **Service Tag Settings**.
4. Enter the Service Tag.

 **NOTE:** You can enter the Service Tag only when the **Service Tag** field is empty. Ensure that you enter the correct Service Tag. After the Service Tag is entered, it cannot be updated or changed.

5. Click **OK**.
6. Import your new or existing iDRAC Enterprise license.

For more information, see the *Integrated Dell Remote Access Controller User's Guide* at www.dell.com/poweredge manuals.

Restoring the Service Tag by using the Easy Restore feature

By using the Easy Restore feature, you can restore your Service Tag, license, UEFI configuration, and the system configuration data after replacing the system board. All data is automatically backed up in a backup flash device. If BIOS detects a new system board and the Service Tag in the backup flash device, BIOS prompts the user to restore the backup information.

Steps

1. Turn on the system.
If BIOS detects a new system board, and if the Service Tag is present in the backup flash device, BIOS displays the Service Tag, the status of the license, and the **UEFI Diagnostics** version.
2. Perform one of the following steps:
 - Press **Y** to restore the Service Tag, license, and diagnostics information.
 - Press **N** to navigate to the Dell Lifecycle Controller based restore options.
 - Press F10 to restore data from a previously created **Hardware Server Profile**.

After the restore process is complete, BIOS prompts to restore the system configuration data.

3. Perform one of the following steps:
 - Press **Y** to restore the system configuration data.
 - Press **N** to use the default configuration settings.

After the restore process is complete, the system restarts.

Trusted Platform Module

Trusted Platform Module (TPM) is a dedicated microprocessor designed to secure hardware by integrating cryptographic keys into devices. A software can use a Trusted Platform Module to authenticate hardware devices. As each TPM chip has a unique and secret RSA key burned in as it is produced, it can perform the platform authentication.

 **CAUTION:** Do not attempt to remove the Trusted Platform Module (TPM) from the system board. After the TPM is installed, it is cryptographically bound to that specific system board. Any attempt to remove an installed TPM breaks the cryptographic binding, and it cannot be re-installed or installed on another system board.

 **NOTE:** This is a Field Replaceable Unit (FRU). Removal and installation procedures must be performed only by Dell certified service technicians.

Installing the Trusted Platform Module

Prerequisites

CAUTION: Many repairs may only be done by a certified service technician. You should only perform troubleshooting and simple repairs as authorized in your product documentation, or as directed by the online or telephone service and support team. Damage due to servicing that is not authorized by Dell is not covered by your warranty. Read and follow the safety instructions that are shipped with your product.

1. Follow the safety guidelines listed in the Safety instructions section.
2. Follow the procedure listed in the Before working inside your system section.

Steps

1. Locate the TPM connector on the system board.

NOTE: To locate the TPM connector on the system board, see the System board connectors section.

2. Align the edge connectors on the TPM with the slot on the TPM connector.
3. Insert the TPM into the TPM connector such that the plastic rivet aligns with the slot on the system board.
4. Press the plastic rivet until the rivet snaps into place.

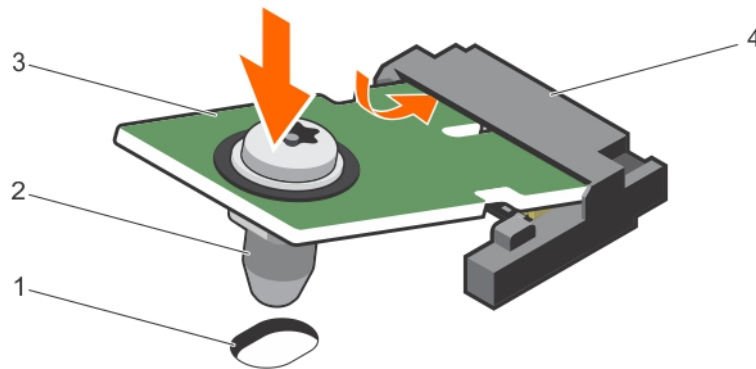

Figure 95. Installing the TPM

- | | |
|-----------------------------------|------------------|
| 1. rivet slot on the system board | 2. plastic rivet |
| 3. TPM | 4. TPM connector |

Next steps

1. Install the system board.
2. Follow the procedure listed in the After working inside your system section.

Related references

[Safety instructions](#) on page 63

Related tasks

[Before working inside your system](#) on page 64

[Installing the system board](#) on page 161

[After working inside your system](#) on page 64

Initializing the TPM for BitLocker users

Steps

Initialize the TPM.

For more information about initializing the TPM, see <https://technet.microsoft.com/en-us/library/cc753140.aspx>.

The **TPM Status** changes to **Enabled, Activated**.

Initializing the TPM for TXT users

Steps

1. While booting your system, press F2 to enter System Setup.
2. On the **System Setup Main Menu** screen, click **System BIOS > System Security Settings**.
3. From the **TPM Security** option, select **On with Pre-boot Measurements**.
4. From the **TPM Command** option, select **Activate**.
5. Save the settings.
6. Restart your system.
7. Enter **System Setup** again.
8. On the **System Setup Main Menu** screen, click **System BIOS > System Security Settings**.
9. From the **Intel TXT** option, select **On**.

Using system diagnostics

If you experience a problem with your system, run the system diagnostics before contacting Dell for technical assistance. The purpose of running system diagnostics is to test your system hardware without using additional equipment or risking data loss. If you are unable to fix the problem yourself, service and support personnel can use the diagnostics results to help you solve the problem.

NOTE: For more information about OEM diagnostic event messages, see the Event and Error Message Reference Guide for 13th Generation Dell PowerEdge Servers Version 1.2

Topics:

- [Dell Embedded System Diagnostics](#)

Dell Embedded System Diagnostics

NOTE: The Dell Embedded System Diagnostics is also known as Enhanced Pre-boot System Assessment (ePSA) diagnostics.

The Embedded System Diagnostics provides a set of options for particular device groups or devices allowing you to:

- Run tests automatically or in an interactive mode
- Repeat tests
- Display or save test results
- Run thorough tests to introduce additional test options to provide extra information about the failed device(s)
- View status messages that inform you if tests are completed successfully
- View error messages that inform you of problems encountered during testing

When to use the Embedded System Diagnostics

Run the Embedded System Diagnostics (ePSA) if your system does not boot.

Running the Embedded System Diagnostics from Boot Manager

Prerequisites

Run the Embedded System Diagnostics (ePSA) if your system does not boot.

Steps

1. When the system is booting, press F10.
2. Use the up arrow and down arrow keys to select **System Utilities > Launch Diagnostics**. The **ePSA Pre-boot System Assessment** window is displayed, listing all devices detected in the system. The diagnostics starts executing the tests on all the detected devices.

Running the Embedded System Diagnostics from the Dell Lifecycle Controller

Steps

1. As the system boots, press F10.
2. Select **Hardware Diagnostics** → **Run Hardware Diagnostics**.

The **ePSA Pre-boot System Assessment** window is displayed, listing all devices detected in the system. The diagnostics starts executing the tests on all the detected devices.

System diagnostic controls

Menu	Description
Configuration	Displays the configuration and status information of all detected devices.
Results	Displays the results of all tests that are run.
Systemhealth	Provides the current overview of the system performance.
Event log	Displays a time-stamped log of the results of all tests run on the system. This is displayed if at least one event description is recorded.





Jumpers and connectors

Topics:

- System board jumper settings
- System Board Connectors
- Disabling forgotten password

System board jumper settings

Table 36. System board jumper settings

Jumper	Setting	Description
PWRD_EN	 2 4 6 (default)	The password reset feature is enabled (pins 2–4). BIOS local access is unlocked at the next AC power cycle.
	 2 4 6	The password reset feature is disabled (pins 4–6).
NVRAM_CLR	 1 3 5 (default)	The configuration settings are retained at the next system boot (pins 3–5).
	 1 3 5	The configuration settings are cleared at system boot (pins 1–3).

System Board Connectors

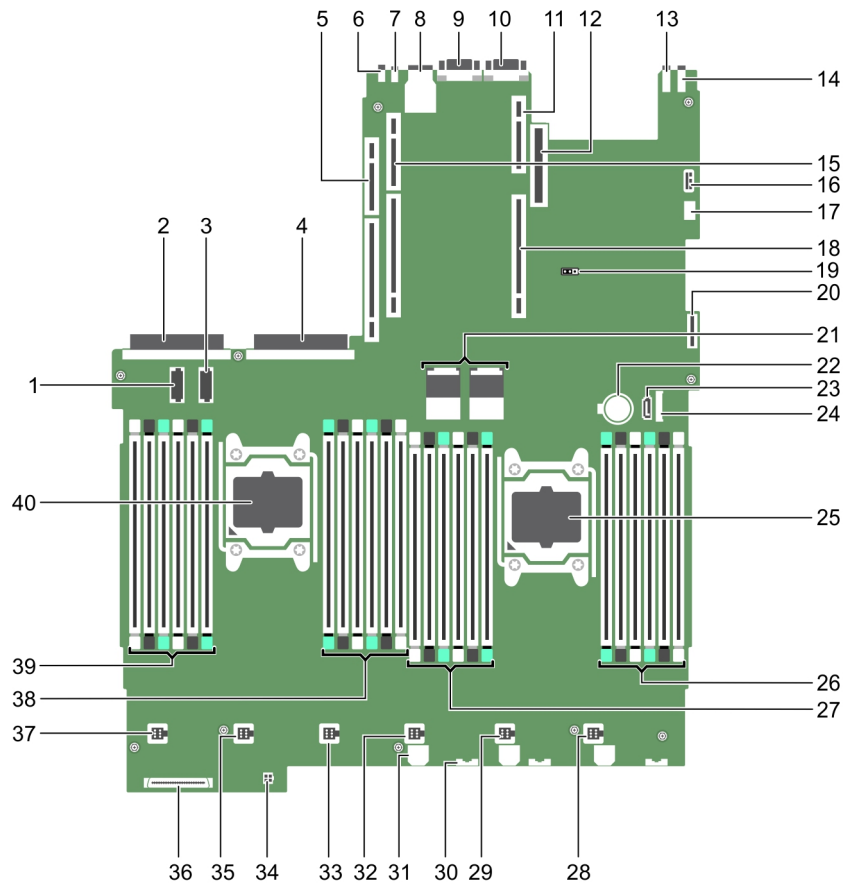

Figure 96. System Board Connectors

Table 37. System board connectors and descriptions

Item	Connector	Description
1	J_P12V_PWR	Processor expansion module power connectors
2	PS2	PSU 2 power connector
3	J_P12V_PWR	Processor expansion module power connectors
4	PS1	PSU 1 power connector
5	IO_RISER3	Riser 3 connector
6	CYC_ID	System identification button
7	CYC	System identification connector
8	IDRAC	iDRAC8 connector
9	VGA	Video connector
10	COM1	Serial connector
11	IO_RISER1	Riser 1 connector
12	NDC	Network daughter card connector
13	USB_REAR_2	USB rear connector 2
14	USB_REAR_1	USB rear connector 1

Table 37. System board connectors and descriptions (continued)

Item	Connector	Description
15	IO_RISER2	Riser 2 connector
16	USB_INT	Internal USB connector
17	SPIVU	SPIVU connector
18	IO_RISER1	Riser 1 connector
19	NVRAM_CLR/PWRD_EN	NVRAM/PASSWORD CLEAR jumper
20	IDSDM	Internal Dual SD Module
21	QPI CONNECTOR	QPI connector
22	BATTERY	System battery
23	SATA_CD	Optical drive SATA connector
24	FP_USB	Front panel USB connector
25	CPU2	Processor socket 2
26	B10, B6, B2, B9, B5, B1	Memory module sockets
27	B3, B7, B11, B4, B8, B12	Memory module sockets
28	FAN6	Cooling fan connector
29	FAN5	Cooling fan connector
30	BP SIG	Backplane signal connector
31	BP POWER	Backplane power connector
32	FAN4	Cooling fan connector
33	FAN3	Cooling fan connector
34	SATA_PWR	SATA power connector
35	FAN2	Cooling fan connector
36	CTRL PNL	Control panel interface connector
37	FAN1	Cooling fan connector
38	A10, A6, A2, A9, A5, A1	Memory module sockets
39	A3, A7, A11, A4, A8, A12	Memory module sockets
40	CPU1	Processor socket 1

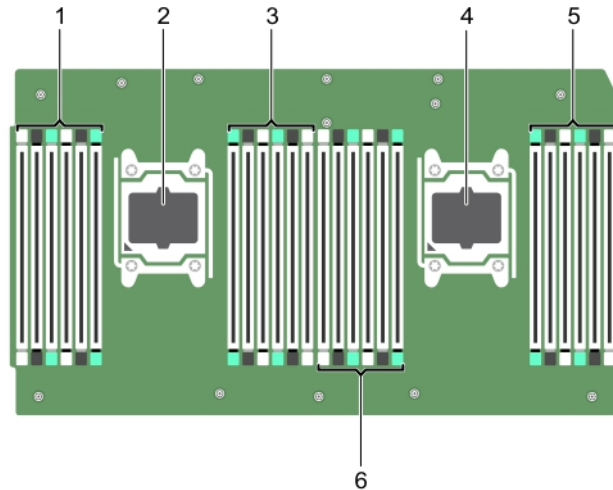

Figure 97. Processor expansion module connectors

Table 38. Processor expansion module connectors and descriptions

Item	Connector	Description
1	D3, D7, D11, D4, D8, D12	Memory module sockets
2	CPU4	Processor socket 4
3	D10, D6, D2, D9, D5, D1	Memory module sockets
4	CPU3	Processor socket 3
5	C10, C6, C2, C9, C5, C1	Memory module sockets
6	C3, C7, C11, C4, C8, C12	Memory module sockets

Disabling forgotten password

The software security features of the system include a system password and a setup password. The password jumper enables or disables password features and clears any password(s) currently in use.

Prerequisites

Steps

1. Turn off the system, including any attached peripherals, and disconnect the system from the electrical outlet.
2. Remove the system cover.
3. Move the jumper on the system board jumper from pins 4 and 6 to pins 2 and 4.
4. Install the system cover.

The existing passwords are not disabled (erased) until the system boots with the jumper on pins 2 and 4. However, before you assign a new system and/or setup password, you must move the jumper back to pins 4 and 6.

NOTE: If you assign a new system and/or setup password with the jumper on pins 2 and 4, the system disables the new password(s) the next time it boots.

5. Reconnect the system to its electrical outlet and turn on the system, including any attached peripherals.
6. Turn off the system, including any attached peripherals, and disconnect the system from the electrical outlet.
7. Remove the system cover.
8. Move the jumper on the system board jumper from pins 2 and 4 to pins 4 and 6.

9. Install the system cover.
10. Reconnect the system to its electrical outlet and turn on the system, including any attached peripherals.
11. Assign a new system and/or setup password.

Related tasks

[Removing the system cover](#) on page 66

[Installing the system cover](#) on page 67

Troubleshooting your system

Safety first — for you and your system

CAUTION: Many repairs may only be done by a certified service technician. You should only perform troubleshooting and simple repairs as authorized in your product documentation, or as directed by the online or telephone service and support team. Damage due to servicing that is not authorized by Dell is not covered by your warranty. Read and follow the safety instructions that are shipped with your product.

NOTE: Solution validation was performed by using the factory shipped hardware configuration.

Topics:

- [Troubleshooting system startup failure](#)
- [Troubleshooting external connections](#)
- [Troubleshooting the video subsystem](#)
- [Troubleshooting a USB device](#)
- [Troubleshooting iDRAC Direct - USB XML configuration](#)
- [Troubleshooting iDRAC Direct - Laptop connection](#)
- [Troubleshooting a serial input and output device](#)
- [Troubleshooting a NIC](#)
- [Troubleshooting a wet system](#)
- [Troubleshooting a damaged system](#)
- [Troubleshooting the system battery](#)
- [Troubleshooting power supply units](#)
- [Troubleshooting cooling problems](#)
- [Troubleshooting cooling fans](#)
- [Troubleshooting system memory](#)
- [Troubleshooting an internal USB key](#)
- [Troubleshooting a micro SD card](#)
- [Troubleshooting an optical drive](#)
- [Troubleshooting a tape backup unit](#)
- [Troubleshooting a drive or SSD](#)
- [Troubleshooting a storage controller](#)
- [Troubleshooting expansion cards](#)
- [Troubleshooting processors](#)
- [System messages](#)

Troubleshooting system startup failure

If you boot the system to the BIOS boot mode after installing an operating system from the UEFI Boot Manager, the system stops responding. To avoid this issue, you must boot to the same boot mode in which you installed the operating system.

For all other startup issues, note the system messages that appear on the screen.

Troubleshooting external connections

Before troubleshooting any external devices, ensure that all external cables are securely attached to the external connectors on your system.

- Compare the technical specification of the system with the external device to check the compatibility.
- Check the external device functionality with some other similar system so that we are sure that the device is working fine.
- Check any other similar external device with this system so that we are sure that the system port is working fine.

For any further queries contact, [Global Technical Support](#).

Troubleshooting the video subsystem

Prerequisites

NOTE: Ensure that the **Local Server Video Enabled** option is selected in the iDRAC Graphical User Interface (GUI), under **Virtual Console**. If this option is not selected, local video is disabled.

NOTE: The VGA ports are not hot-pluggable.

Steps

1. Check the cable connections (power and display) to the monitor.
2. Check the video interface cabling from the system to the monitor.

Results

If the tests run successfully, the problem is not related to video hardware.

Next steps

If the tests fail, see the Getting help section.

Related references

[Getting help](#) on page 188

Troubleshooting a USB device

Prerequisites

NOTE: Follow steps 1 to 6 to troubleshoot a USB keyboard or mouse. For other USB devices, go to step 7.

Steps

1. Disconnect the keyboard and/or mouse cables from the system and reconnect them.
2. If the problem persists, connect the keyboard and/or mouse to another USB port on the system.
3. If the problem is resolved, restart the system, enter System Setup, and check if the non-functioning USB ports are enabled.

NOTE: Older operating systems may not support USB 3.0.

4. Check if USB 3.0 is enabled in System Setup. If enabled, disable it and see if the issue is resolved.
5. In **iDRAC Settings Utility**, ensure that **USB Management Port Mode** is configured as **Automatic** or **Standard OS Use**.
6. If the problem is not resolved, replace the keyboard and/or mouse with a known working keyboard or mouse.
If the problem is not resolved, proceed to step 7 to troubleshoot other USB devices attached to the system.
If the problem is not resolved, proceed to troubleshoot other USB devices attached to the system.
7. Turn off all attached USB devices, and disconnect them from the system.
8. Restart the system.
9. If your keyboard is functioning, enter System Setup, verify that all USB ports are enabled on the **Integrated Devices** screen. If your keyboard is not functioning, use remote access to enable or disable the USB options.
10. Check if USB 3.0 is enabled in System Setup. If it is enabled, disable it and restart your system.

11. If the system is not accessible, reset the NVRAM_CLR jumper inside your system and restore the BIOS to the default settings. See the System board jumper setting section
12. In the **iDRAC Settings Utility**, ensure that **USB Management Port Mode** is configured as **Automatic** or **Standard OS Use**.
13. Reconnect and turn on each USB device one at a time.
14. If a USB device causes the same problem, turn off the device, replace the USB cable with a known good cable, and turn on the device.

Next steps

If all troubleshooting fails, see the Getting help section.

Related concepts

[System Setup](#) on page 34

Related references

[Getting help](#) on page 188

Troubleshooting iDRAC Direct - USB XML configuration

For information about USB storage device and system configuration, see *Integrated Dell Remote Access Controller User's Guide* at www.dell.com/poweredgemanuals

Steps

1. Ensure that your USB storage device is connected to the front USB Management Port, identified by  icon.
2. Ensure that your USB storage device is configured with an NTFS or an FAT32 file system with only one partition.
3. Verify that the USB storage device is configured correctly. For more information about configuring the USB storage device, see *Integrated Dell Remote Access Controller User's Guide* at www.dell.com/poweredgemanuals
4. In the **iDRAC Settings Utility**, ensure that **USB Management Port Mode** is configured as **Automatic** or **iDRAC Direct Only**.
5. Ensure that the **iDRAC Managed: USB XML Configuration** option is either **Enabled** or **Enabled only when the server has default credential settings**.
6. Remove and reinsert the USB storage device.
7. If import operation does not work, try with a different USB storage device.

Next steps

If all troubleshooting fails, see the Getting help section.

Related references

[Getting help](#) on page 188

Troubleshooting iDRAC Direct - Laptop connection

For information about USB laptop connection and system configuration, see the *Integrated Dell Remote Access Controller User's Guide* at www.dell.com/poweredgemanuals.

Steps

1. Ensure that your laptop is connected to the front USB Management Port, identified by  icon with a USB Type A/A cable.

2. On the **iDRAC Settings Utility** screen, ensure that **USB Management Port Mode** is configured as **Automatic** or **iDRAC Direct Only**.
3. If the laptop is running Windows operating system, ensure that the iDRAC Virtual USB NIC device driver is installed.
4. If the driver is installed, ensure that you are not connected to any network through WiFi or cabled ethernet, as iDRAC Direct uses a non-routable address.

Next steps

If all troubleshooting fails, see the Getting help section.

Related references

[Getting help](#) on page 188

Troubleshooting a serial input and output device

Prerequisites

Steps

1. Turn off the system and any peripheral devices connected to the serial port.
2. Swap the serial interface cable with a known working cable, and turn on the system and the I/O serial device.
If the problem is resolved, replace the interface cable with a known working cable.
3. Turn off the system and the I/O serial device, and swap the serial device with a compatible device.
4. Turn on the system and the I/O serial device.

Next steps

If the problem persists, see the Getting help section.

Related references

[Getting help](#) on page 188

Troubleshooting a NIC

Prerequisites

 **NOTE:** Network Daughter Card (NDC) slot is not hot-pluggable.

Steps

1. Run the appropriate diagnostic test. For more information, see the Using system diagnostics section for the available diagnostic tests.
2. Restart the system and check for any system messages pertaining to the NIC controller.
3. Check the appropriate indicator on the NIC connector:
 - If the link indicator does not glow, the cable connected might be disengaged.
 - If the activity indicator does not glow, the network driver files might be damaged or missing. Install or replace the drivers as necessary. For more information, see the NIC documentation.
 - Try another known good network cable.
 - If the problem persists, use another connector on the switch or hub.
4. Ensure that the appropriate drivers are installed and the protocols are bound. For more information, see the NIC documentation.
5. Enter System Setup and confirm that the NIC ports are enabled on the **Integrated Devices** screen.

6. Ensure that all the NICs, hubs, and switches on the network are set to the same data transmission speed and duplex. For more information, see the documentation for each network device.
7. Ensure that all the NICs and switches on the network are set to the same data transmission speed and duplex. For more information, see the documentation for each network device.
8. Ensure that all network cables are of the proper type and do not exceed the maximum length.

Next steps

If the problem persists, see the Getting help section.

Related references

[Getting help](#) on page 188

[Using system diagnostics](#) on page 166

Troubleshooting a wet system

Prerequisites

 **CAUTION:** Many repairs may only be done by a certified service technician. You should only perform troubleshooting and simple repairs as authorized in your product documentation, or as directed by the online or telephone service and support team. Damage due to servicing that is not authorized by Dell is not covered by your warranty. Read and follow the safety instructions that are shipped with your product.

Steps

1. Turn off the system and attached peripherals, and disconnect the system from the electrical outlet.
2. Remove the system cover.
3. Remove the following components (if installed) from the system:
 - Power supply unit(s)
 - Optical drive
 - Hard drives
 - Hard drive backplane
 - USB memory key
 - Hard drive tray
 - Cooling shroud
 - Expansion card risers (if installed)
 - Expansion cards
 - Cooling fan assembly (if installed)
 - Cooling fan(s)
 - Memory modules
 - Processor(s) and heat sink(s)
 - System board
4. Let the system dry thoroughly for at least 24 hours.
5. Reinstall the components you removed in step 3 except the expansion cards.
6. Install the system cover.
7. Turn on the system and attached peripherals.

If the problem persists, see the Getting help section.

8. If the system starts properly, turn off the system, and reinstall all the expansion cards that you removed.
9. Run the appropriate diagnostic test. For more information, see the Using system diagnostics section.

Next steps

If the tests fail, see the Getting help section.

Related references

[Getting help](#) on page 188

[Using system diagnostics](#) on page 166

Troubleshooting a damaged system

Prerequisites

CAUTION: Many repairs may only be done by a certified service technician. You should only perform troubleshooting and simple repairs as authorized in your product documentation, or as directed by the online or telephone service and support team. Damage due to servicing that is not authorized by Dell is not covered by your warranty. Read and follow the safety instructions that are shipped with your product.

Steps

1. Turn off the system and attached peripherals, and disconnect the system from the electrical outlet.
2. Remove the system cover.
3. Ensure that the following components are properly installed:
 - cooling shroud
 - expansion card risers (if installed)
 - expansion cards
 - power supply unit(s)
 - cooling fan assembly (if installed)
 - cooling fan(s)
 - processor(s) and heat sink(s)
 - memory modules
 - drive carriers or cage
 - drive backplane
4. Ensure that all cables are properly connected.
5. Install the system cover.
6. Run the appropriate diagnostic test. For more information, see the Using system diagnostics section.

Next steps

If the problem persists, see the Getting help section.

Related references

[Getting help](#) on page 188

[Using system diagnostics](#) on page 166

Troubleshooting the system battery

Prerequisites

CAUTION: Many repairs may only be done by a certified service technician. You should only perform troubleshooting and simple repairs as authorized in your product documentation, or as directed by the online or telephone service and support team. Damage due to servicing that is not authorized by Dell is not covered by your warranty. Read and follow the safety instructions that are shipped with your product.

NOTE: If the system is turned off for long periods of time (for weeks or months), the NVRAM may lose the system configuration information. This situation is caused by a defective battery.

NOTE: Some software may cause the system time to speed up or slow down. If the system seems to operate normally except for the time set in System Setup, the problem may be caused by a software, rather than by a defective battery.

Steps

1. Re-enter the time and date in System Setup.
2. Turn off the system, and disconnect it from the electrical outlet for at least an hour.
3. Reconnect the system to the electrical outlet, and turn on the system.
4. Enter System Setup.

If the date and time displayed in System Setup are not correct, check the System Error Log (SEL) for system battery messages.

Next steps

If the problem persists, see the Getting help section.

Related concepts

[System Setup](#) on page 34

Related references

[Getting help](#) on page 188

Troubleshooting power supply units

Prerequisites

 **CAUTION:** Many repairs may only be done by a certified service technician. You should only perform troubleshooting and simple repairs as authorized in your product documentation, or as directed by the online or telephone service and support team. Damage due to servicing that is not authorized by Dell is not covered by your warranty. Read and follow the safety instructions that are shipped with your product.

The following sections provide information on troubleshooting power source and power supply units problems.

 **NOTE:** Power Supply Units (PSUs) are hot-pluggable.

Troubleshooting power source problems

Steps

1. Press the power button to ensure that your system is turned on. If the power indicator does not glow when the power button is pressed, press the power button firmly.
2. Plug in another working power supply unit to ensure that the system board is not faulty.
3. Ensure that no loose connections exist.
For example, loose power cables.
4. Ensure that the power source meets applicable standards.
5. Ensure that there are no short circuits.
6. Have a qualified electrician check the line voltage to ensure that it meets the needed specifications.

Results

 **NOTE:** Some power supply units require 200-240V AC to deliver their rated capacity. For more information, see the system Technical Specifications section in the Installation and Service Manual available at www.dell.com/poweredgemanuals.

Troubleshooting power supply unit problems

Steps

1. Ensure that no loose connections exist.

For example, loose power cables.

2. Ensure that the power supply handle LED indicates that the power supply is working properly.
3. If you have recently upgraded your system, ensure that the power supply unit has enough power to support the new system.
4. If you have a redundant power supply configuration, ensure that both the power supply units are of the same type and wattage.

If the LED You may have to upgrade to a higher wattage power supply unit.

5. Ensure that you use only power supply units with the Extended Power Performance (EPP) label on the back.
6. Reseat the power supply unit.

 **NOTE:** After installing a power supply unit, allow several seconds for the system to recognize the power supply unit and determine if it is working properly.

If the problem persists, see the Getting help section.

Troubleshooting cooling problems

 **CAUTION:** Many repairs may only be done by a certified service technician. You should only perform troubleshooting and simple repairs as authorized in your product documentation, or as directed by the online or telephone service and support team. Damage due to servicing that is not authorized by Dell is not covered by your warranty. Read and follow the safety instructions that are shipped with your product.

Ensure that the following conditions exist:

- System cover, cooling shroud, EMI filler panel, or back filler bracket is not removed.
- Ambient temperature is not higher than the system specific ambient temperature.
- External airflow is not obstructed.
- A cooling fan is not removed or has not failed.
- The expansion card installation guidelines have been followed.

Additional cooling can be added by one of the following methods:

From the iDRAC web GUI:

1. Click **Hardware > Fans > Setup**.
2. From the **Fan Speed Offset** drop-down list, select the cooling level that is required or set the minimum fan speed to a custom value.

From F2 System Setup:

1. Select **iDRAC Settings > Thermal**, and set a higher fan speed from the fan speed offset or minimum fan speed.

From RACADM commands:

1. Run the command `racadm help system.thermalsettings`

For more information, see *Integrated Dell Remote Access User's Guide* at www.dell.com/poweredgemanuals

Troubleshooting cooling fans

Prerequisites

 **CAUTION:** Many repairs may only be done by a certified service technician. You should only perform troubleshooting and simple repairs as authorized in your product documentation, or as directed by the online or telephone service and support team. Damage due to servicing that is not authorized by Dell is not covered by your warranty. Read and follow the safety instructions that are shipped with your product.

 **NOTE:** The fan number is referenced by the management software of the system. In the event of a problem with a particular fan, you can easily identify and replace it by noting down the fan numbers on the cooling fan assembly.

1. Follow the safety guidelines listed in the Safety instructions section.
2. Follow the procedure listed in the Before working inside your system section.

Steps

1. Reseat the fan or the fan's power cable.
2. Restart the system.

Next steps

1. Follow the procedure listed in the After working inside your system section.
2. If the problem persists, see the Getting help section.

Related references

[Safety instructions](#) on page 63

[Getting help](#) on page 188

Troubleshooting system memory

Prerequisites

CAUTION: Many repairs may only be done by a certified service technician. You should only perform troubleshooting and simple repairs as authorized in your product documentation, or as directed by the online or telephone service and support team. Damage due to servicing that is not authorized by Dell is not covered by your warranty. Read and follow the safety instructions that are shipped with your product.

NOTE: Memory slots are not hot-pluggable.

NOTE: NVDIMM-N battery is not hot-pluggable.

Steps

1. If the system is operational, run the appropriate diagnostic test. See the Using system diagnostics section for the available diagnostic tests.
If the diagnostic tests indicate a fault, follow the corrective actions that are provided by the diagnostic tests.
2. If the system is not operational, turn off the system and attached peripherals, and unplug the system from the power source. Wait at least for 10 seconds, and then reconnect the system to the power source.
3. Turn on the system and attached peripherals, and note the messages on the screen.
If an error message is displayed indicating a fault with a specific memory module, go to step 12.
4. Enter System Setup, and check the system memory setting. Make any changes to the memory settings, if needed.
If the memory settings match the installed memory but the problem still persists, go to step 12.
5. Turn off the system and attached peripherals, and disconnect the system from the electrical outlet.
6. Remove the system cover.
7. Check the memory channels and ensure that they are populated correctly.
NOTE: See the system event log or system messages for the location of the failed memory module. Reinstall the memory device.
8. Reseat the memory modules in their sockets.
9. Install the system cover.
10. Enter System Setup, and check the system memory setting.
If the problem is not resolved, proceed with step 11.
11. Remove the system cover.
12. If a diagnostic test or error message indicates a specific memory module as faulty, swap or replace the module with a known working memory module.
13. To troubleshoot an unspecified faulty memory module, replace the memory module in the first DIMM socket with a module of the same type and capacity.

If an error message is displayed on the screen, this may indicate a problem with one or more installed DIMM types, incorrect DIMM installation, or defective DIMMs. Follow the on-screen instructions to resolve the problem.

14. Install the system cover.
15. As the system boots, observe any error message that is displayed and the diagnostic indicators on the front of the system.
16. If the memory problem persists, repeat step 12 through step 15 for each memory module installed.

Next steps

If the problem persists, see the Getting help section.

Related references

[Getting help](#) on page 188

[Using system diagnostics](#) on page 166

Troubleshooting an internal USB key

Prerequisites

 **CAUTION: Many repairs may only be done by a certified service technician. You should only perform troubleshooting and simple repairs as authorized in your product documentation, or as directed by the online or telephone service and support team. Damage due to servicing that is not authorized by Dell is not covered by your warranty. Read and follow the safety instructions that are shipped with your product.**

Steps

1. Enter System Setup and ensure that the **USB key port** is enabled on the **Integrated Devices** screen.
2. Turn off the system and attached peripherals, and disconnect the system from the electrical outlet.
3. Remove the system cover.
4. Locate the USB key and reseal it.
5. Install the system cover.
6. Turn on the system and attached peripherals, and check if the USB key is functioning.
7. If the problem is not resolved, repeat step 2 and step 3.
8. Insert a known working USB key.
9. Install the system cover.

Next steps

If the problem persists, see the Getting help section.

Related concepts

[System Setup](#) on page 34

Related references

[Getting help](#) on page 188



[System Board Connectors](#) on page 169

Related tasks

[Removing the system cover](#) on page 66

Troubleshooting a micro SD card

Prerequisites

-  **NOTE:** Certain micro SD cards have a physical write-protect power on the card. If the write-protect switch is turned on, the micro SD card is not writable.
-  **NOTE:** IDSDM and vFlash slots are not hot-pluggable.

Steps

1. Enter System Setup, and ensure that the **Internal SD Card Port** is enabled.
2. Turn off the system, including any attached peripherals, and disconnect the system from the electrical outlet.
3. Remove the system cover.
 -  **NOTE:** When an SD card failure occurs, the internal dual SD module controller notifies the system. On the next restart, the system displayed a message indicating the failure. If redundancy is enabled at the time of SD card failure, a critical alert is logged and chassis health will degrade.
4. Replace the failed micro SD card with a new micro SD card.
5. Install the system cover.
6. Reconnect the system to its electrical outlet and turn on the system, including any attached peripherals.
7. Enter System Setup, and ensure that the **Internal SD Card Port** and **Internal SD Card Redundancy** modes are set to the needed modes.

Verify that the correct SD slot is set as **Primary SD Card**.
8. Check if the micro SD card is functioning properly.
9. If the **Internal SD Card Redundancy** option is set to **Enabled** at the time of the SD card failure, the system prompts you to perform a rebuild.
 -  **NOTE:** The rebuild is always sourced from the primary SD card to the secondary SD card.

Troubleshooting an optical drive

Prerequisites

-  **CAUTION:** Many repairs may only be done by a certified service technician. You should only perform troubleshooting and simple repairs as authorized in your product documentation, or as directed by the online or telephone service and support team. Damage due to servicing that is not authorized by Dell is not covered by your warranty. Read and follow the safety instructions that are shipped with your product.

Steps

1. Try using a different CD or DVD.
2. If the problem is not resolved, enter System Setup and ensure that the integrated SATA controller and the drive's SATA port are enabled.
3. Run the appropriate diagnostic test.
4. Turn off the system and attached peripherals, and disconnect the system from the electrical outlet.
5. If installed, remove the bezel.
6. Remove the system cover.
7. Ensure that the interface cable is securely connected to the optical drive and to the controller.
8. Ensure that a power cable is properly connected to the drive.
9. Install the system cover.

Next steps

If the problem persists, see the Getting help section.

Related references

[Getting help](#) on page 188

Troubleshooting a tape backup unit

Prerequisites

 **CAUTION:** Many repairs may only be done by a certified service technician. You should only perform troubleshooting and simple repairs as authorized in your product documentation, or as directed by the online or telephone service and support team. Damage due to servicing that is not authorized by Dell is not covered by your warranty. Read and follow the safety instructions that are shipped with your product.

Steps

1. Use a different tape cartridge.
2. Ensure that the device drivers for the tape backup unit are installed and are configured correctly. See your tape drive documentation for more information about device drivers.
3. Reinstall the tape-backup software as instructed in the tape-backup software documentation.
4. Ensure that the interface cable of the tape drive is connected to the external port on the controller card.
5. Perform the following steps to ensure that the controller card is properly installed:
 - a. Turn off the system and attached peripherals, and disconnect the system from the electrical outlet.
 - b. Remove the system cover.
 - c. Reseat the controller card in the expansion card slot.
 - d. Install the system cover.
 - e. Turn on the system and attached peripherals.
6. Run the appropriate diagnostic test. For more information, see the Using system diagnostics.

Next steps

If you cannot resolve the problem, see the Getting help section.

Related references

[Getting help](#) on page 188

[Using system diagnostics](#) on page 166

Troubleshooting a drive or SSD

Prerequisites

 **CAUTION:** This troubleshooting procedure can erase data stored on the drive. Before you proceed, back up all files on the drive.

 **CAUTION:** Many repairs may only be done by a certified service technician. You should only perform troubleshooting and simple repairs as authorized in your product documentation, or as directed by the online or telephone service and support team. Damage due to servicing that is not authorized by Dell is not covered by your warranty. Read and follow the safety instructions that are shipped with your product.

Steps

1. Run the appropriate diagnostic test. See the Using system diagnostics section.
Depending on the results of the diagnostics test, proceed as required through the following steps.

2. If your system has a RAID controller and your drives are configured in a RAID array, perform the following steps:
 - a. Restart the system and press F10 during system startup to run the Dell Lifecycle Controller, and then run the Hardware Configuration wizard to check the RAID configuration.
See the Dell Lifecycle Controller documentation or online help for information about RAID configuration.
 - b. Ensure that the drives are configured correctly for the RAID array.
 - c. Take the drive offline and reseal the drive.
 - d. Exit the configuration utility and allow the system to boot to the operating system.
3. Ensure that the needed device drivers for your controller card are installed and are configured correctly. For more information, see the operating system documentation.
4. Restart the system and enter the System Setup.
5. Verify that the controller is enabled and the drives are displayed in the System Setup.

Next steps

If the problem persists, see the Getting help section.

Related concepts

[System Setup](#) on page 34

Related references

[Getting help](#) on page 188

[Using system diagnostics](#) on page 166

Troubleshooting a storage controller

CAUTION: Many repairs may only be done by a certified service technician. You should only perform troubleshooting and simple repairs as authorized in your product documentation, or as directed by the online or telephone service and support team. Damage due to servicing that is not authorized by Dell is not covered by your warranty. Read and follow the safety instructions that are shipped with your product.

NOTE: When troubleshooting a controller, see the documentation for your operating system and the controller.

NOTE: Mini-PERC socket is not hot-pluggable.

1. Run the appropriate diagnostic test. See the Using system diagnostics section.
2. Turn off the system and attached peripherals, and disconnect the system from the electrical outlet.
3. Remove the system cover.
4. Verify that the installed expansion cards are compliant with the expansion card installation guidelines.
5. Ensure that each expansion card is firmly seated in its connector.
6. Install the system cover.
7. Reconnect the system to the electrical outlet, and turn on the system and attached peripherals.
8. If the problem is not resolved, turn off the system and attached peripherals, and disconnect the system from the electrical outlet.
9. Remove the system cover.
10. Remove all expansion cards installed in the system.
11. Install the system cover.
12. Reconnect the system to the electrical outlet, and turn on the system and attached peripherals.
13. Run the appropriate diagnostic test. See the Using system diagnostics section.

If the tests fail, see the Getting help section.

14. For each expansion card you removed in step 10, perform the following steps:
 - a. Turn off the system and attached peripherals, and disconnect the system from the electrical outlet.
 - b. Remove the system cover.
 - c. Reinstall one of the expansion cards.
 - d. Install the system cover.

- e. Run the appropriate diagnostic test. See the Using system diagnostics section.

If the problem persists, see the Getting help section.

Related references

[Getting help](#) on page 188

[Using system diagnostics](#) on page 166

Troubleshooting expansion cards

Prerequisites

 **CAUTION:** Many repairs may only be done by a certified service technician. You should only perform troubleshooting and simple repairs as authorized in your product documentation, or as directed by the online or telephone service and support team. Damage due to servicing that is not authorized by Dell is not covered by your warranty. Read and follow the safety instructions that are shipped with your product.

 **NOTE:** When troubleshooting an expansion card, you also have to see the documentation for your operating system and the expansion card.

 **NOTE:** Riser slots are not hot-pluggable.

Steps

1. Run the appropriate diagnostic test. See the Using system diagnostics section.
2. Turn off the system and attached peripherals, and disconnect the system from the electrical outlet.
3. Remove the system cover.
4. Ensure that each expansion card is firmly seated in its connector.
5. Install the system cover.
6. Turn on the system and attached peripherals.
7. If the problem is not resolved, turn off the system and attached peripherals, and disconnect the system from the electrical outlet.
8. Remove the system cover.
9. Remove all expansion cards installed in the system.
10. Install the system cover.
11. Run the appropriate diagnostic test. See the Using system diagnostics section.
If the tests fail, see the Getting help section.
12. For each expansion card you removed in step 8, perform the following steps:
 - a. Turn off the system and attached peripherals, and disconnect the system from the electrical outlet.
 - b. Remove the system cover.
 - c. Reinstall one of the expansion cards.
 - d. Install the system cover.
 - e. Run the appropriate diagnostic test. See the Using system diagnostics section.

Next steps

If the problem persists, see the Getting help section.

Related references

[Getting help](#) on page 188

[Using system diagnostics](#) on page 166

Troubleshooting processors

Prerequisites

 **CAUTION:** Many repairs may only be done by a certified service technician. You should only perform troubleshooting and simple repairs as authorized in your product documentation, or as directed by the online or telephone service and support team. Damage due to servicing that is not authorized by Dell is not covered by your warranty. Read and follow the safety instructions that are shipped with your product.

 **NOTE:** Processor sockets are not hot-pluggable.

Steps

1. Run the appropriate diagnostics test. See the Using system diagnostics section.
2. Turn off the system and attached peripherals, and disconnect the system from the electrical outlet.
3. Remove the system cover.
4. Ensure that the processor and heat sink are properly installed.
5. Install the system cover.
6. Run the appropriate diagnostic test. See the Using system diagnostics section.
7. If the problem persists, see the Getting help section.

Related references

[Getting help](#) on page 188

[Using system diagnostics](#) on page 166

System messages

For information about the event and error messages generated by the system firmware and agents that monitor system components, go to qrl.dell.com > **Look Up** > **Error Code**, type the error code, and then click **Look it up**.

Warning messages

A warning message alerts you to a possible problem and prompts you to respond before the system continues a task. For example, before you format a hard drive, a message warns you that you may lose all data on the hard drive. Warning messages usually interrupt the task and need you to respond by typing y (yes) or n (no).

 **NOTE:** Warning messages are generated by either the application or the operating system. For more information, see the documentation that shipped with the operating system or application.

Diagnostic messages

The system diagnostic utility generates messages if there are errors detected when you run diagnostic tests on your system. For more information about system diagnostics, see the For information about the event and error messages generated by the system firmware and agents that monitor system components, go to qrl.dell.com > **Look Up** > **Error Code**, type the error code, and then click **Look it up**.

Alert messages

The systems management software generates alert messages for your system. Alert messages include information, status, warning, and failure messages for drive, temperature, fan, and power conditions. For more information, see the systems management software documentation links listed in the Documentation resources section of this manual.

Getting help

Topics:

- [Contacting Dell EMC](#)
- [Documentation feedback](#)
- [Accessing system information by using QRL](#)

Contacting Dell EMC

Dell EMC provides several online and telephone based support and service options. If you do not have an active internet connection, you can find contact information about your purchase invoice, packing slip, bill, or Dell EMC product catalog. Availability varies by country and product, and some services may not be available in your area. To contact Dell EMC for sales, technical assistance, or customer service issues:

Steps

1. Go to www.dell.com/support/home.
2. Select your country from the drop-down menu on the lower right corner of the page.
3. For customized support:
 - a. Enter your system Service Tag in the **Enter your Service Tag** field.
 - b. Click **Submit**.
The support page that lists the various support categories is displayed.
4. For general support:
 - a. Select your product category.
 - b. Select your product segment.
 - c. Select your product.
The support page that lists the various support categories is displayed.
5. For contact details of Dell EMC Global Technical Support:
 - a. Click [Global Technical Support](#).
 - b. Enter your system Service Tag in the **Enter your Service Tag** field on the Contact Us webpage.

Documentation feedback

You can rate the documentation or write your feedback on any of our Dell EMC documentation pages and click **Send Feedback** to send your feedback.

Accessing system information by using QRL

You can use the Quick Resource Locator (QRL) located on the information tag in the front of the system, to access the information about the PowerEdge system.

Prerequisites

Ensure that your smartphone or tablet has the QR code scanner installed.

The QRL includes the following information about your system:

- How-to videos
- Reference materials, including the Installation and Service Manual, LCD diagnostics, and mechanical overview
- Your system service tag to quickly access your specific hardware configuration and warranty information

- A direct link to Dell to contact technical assistance and sales teams

Steps

1. Go to www.dell.com/qrl and navigate to your specific product or
2. Use your smartphone or tablet to scan the model-specific Quick Resource (QR) code on your system or in the Quick Resource Locator section.

Quick Resource Locator for R830

