

# Dell™ PowerEdge™ M905, M805, M600, and M605 Hardware Owner's Manual

# Notes, Notices, and Cautions



**NOTE:** A NOTE indicates important information that helps you make better use of your computer.



**NOTICE:** A NOTICE indicates either potential damage to hardware or loss of data and tells you how to avoid the problem.



**CAUTION:** A CAUTION indicates a potential for property damage, personal injury, or death.

---

**Information in this document is subject to change without notice.**

**© 2007–2008 Dell Inc. All rights reserved.**

Reproduction of these materials in any manner whatsoever without the written permission of Dell Inc. is strictly forbidden.

Trademarks used in this text: *Dell*, the *DELL* logo, *PowerEdge*, and *Dell OpenManage* are trademarks of Dell Inc.; *AMD* and *AMD Opteron* are trademarks of Advanced Micro Devices, Inc.; *Intel* and *Xeon* are registered trademarks of Intel Corporation; *Microsoft*, *MS-DOS*, *Windows*, and *Windows Server* are either trademarks or registered trademarks of Microsoft Corporation in the United States and/or other countries; *Cisco* is a registered trademark of Cisco Systems Inc.

Other trademarks and trade names may be used in this document to refer to either the entities claiming the marks and names or their products. Dell Inc. disclaims any proprietary interest in trademarks and trade names other than its own.

# Contents

1	About Your System . . . . .	11
	<b>Other Information You May Need</b> . . . . .	11
	<b>System Overview</b> . . . . .	12
	<b>System Control Panel Features</b> . . . . .	14
	<b>LCD Module</b> . . . . .	15
	LCD Module Features . . . . .	16
	Using the LCD Module Menus . . . . .	17
	<b>Blade Features</b> . . . . .	20
	Using USB Diskette or USB DVD/CD Drives . . . . .	23
	<b>Hard-Drive Features</b> . . . . .	23
	<b>Back-Panel Features</b> . . . . .	26
	Power Supply Indicator . . . . .	27
	Fan Module Indicators . . . . .	29
	<b>iKVM Module</b> . . . . .	30
	Tiering the Avocent iKVM Switch From a Analog KVM Switch . . . . .	33
	Tiering the Avocent iKVM Switch From a Digital KVM Switch . . . . .	35
	<b>CMC Module</b> . . . . .	38
	<b>I/O Connectivity</b> . . . . .	42
	Guidelines for Installing I/O Modules . . . . .	42
	Mezzanine Cards . . . . .	43

I/O Module Port Mapping . . . . .	46
Cisco SFS M7000e Infiniband Switch Module . . . . .	53
PowerConnect M6220 Ethernet Switch Module . . . . .	54
Cisco Ethernet Switch . . . . .	55
Fibre Channel Pass-through Module . . . . .	58
Brocade M4424 SAN I/O Module . . . . .	61
Ethernet Pass-through Module . . . . .	64
<b>System Messages . . . . .</b>	<b>66</b>
<b>Warning Messages . . . . .</b>	<b>77</b>
<b>Diagnostics Messages . . . . .</b>	<b>78</b>
<b>Alert Messages . . . . .</b>	<b>78</b>
<b>2 Using the System Setup Program . . . . .</b>	<b>79</b>
<b>Entering the System Setup Program . . . . .</b>	<b>79</b>
Responding to Error Messages . . . . .	79
Using the System Setup Program . . . . .	80
<b>System Setup Options . . . . .</b>	<b>80</b>
Main Screen . . . . .	80
Memory Information Screen . . . . .	83
CPU Information Screen . . . . .	84
Integrated Devices Screen . . . . .	85
Serial Communication Screen . . . . .	86
Embedded Server Management Screen . . . . .	87
System Security Screen . . . . .	87
Exit Screen . . . . .	89

<b>System and Setup Password Features</b> . . . . .	<b>90</b>
Using the System Password . . . . .	90
Using the Setup Password . . . . .	93
<b>Disabling a Forgotten Password</b> . . . . .	<b>94</b>
<b>Acquiring the asset.com Utility</b> . . . . .	<b>94</b>
<b>3 Installing Blade Components</b> . . . . .	<b>95</b>
<b>Removing and Installing a Blade</b> . . . . .	<b>96</b>
Removing a Blade . . . . .	96
Installing a Blade . . . . .	98
<b>Removing and Installing a Blade Blank</b> . . . . .	<b>99</b>
Removing a Blade Blank . . . . .	99
Installing a Blade Blank . . . . .	99
<b>Opening and Closing the Blade</b> . . . . .	<b>100</b>
Opening the Blade . . . . .	100
Closing the Blade . . . . .	104
<b>System Memory</b> . . . . .	<b>105</b>
System Memory - PowerEdge M905 . . . . .	105
System Memory - PowerEdge M805 . . . . .	108
System Memory - PowerEdge M600 . . . . .	112
System Memory - PowerEdge M605 . . . . .	114
Installing Memory Modules . . . . .	120
Removing Memory Modules . . . . .	122
<b>I/O Module Mezzanine Cards</b> . . . . .	<b>123</b>
Installing a Mezzanine Card . . . . .	124
Removing a Mezzanine Card . . . . .	126
<b>Installing an SD Card (PowerEdge M905 and M805)</b> . . . . .	<b>126</b>

<b>Integrated NIC Hardware Key</b> . . . . .	<b>127</b>
<b>Processors</b> . . . . .	<b>128</b>
Processor Installation Guidelines . . . . .	128
Removing a Processor . . . . .	129
Installing a Processor . . . . .	136
HT Bridge Card (Service Only) . . . . .	138
<b>Blade System Board NVRAM Backup Battery</b> . . . . .	<b>140</b>
<b>Hard Drives</b> . . . . .	<b>142</b>
Hard-Drive Installation Guidelines . . . . .	142
Installing a Hard Drive . . . . .	142
Removing a Hard Drive . . . . .	143
Configuring the Boot Drive . . . . .	144
Removing a Hard Drive From a Hard-Drive Carrier . . . . .	144
Installing a Hard Drive In a Drive Carrier . . . . .	144
<b>Video Controller</b> . . . . .	<b>145</b>
<b>Hard-Drive Backplane</b> . . . . .	<b>148</b>
<b>Blade System Board (Service Only)</b> . . . . .	<b>150</b>
Removing the System Board . . . . .	150
Installing the System Board . . . . .	153
<b>Storage Controller Card (Service Only)</b> . . . . .	<b>154</b>
Removing the Storage Controller Board . . . . .	154
Installing the Storage Controller Board . . . . .	155
<b>4 Installing Enclosure Components</b> . . . . .	<b>157</b>
<b>Power Supply Modules</b> . . . . .	<b>158</b>
System Power Guidelines . . . . .	158
Power Supply Blanks . . . . .	158

Removing a Power Supply Module . . . . .	159
Installing a Power Supply Module . . . . .	160
<b>Fan Modules . . . . .</b>	<b>161</b>
Removing a Fan Module . . . . .	161
Installing a Fan Module . . . . .	162
<b>CMC Module . . . . .</b>	<b>162</b>
Removing a CMC Module . . . . .	162
Installing an SD Card in the CMC Module . . . . .	164
Installing a CMC Module . . . . .	165
<b>iKVM Module . . . . .</b>	<b>166</b>
Removing an iKVM Module . . . . .	166
Installing an iKVM Module . . . . .	166
<b>I/O Modules . . . . .</b>	<b>166</b>
Removing an I/O Module . . . . .	166
Installing an I/O Module . . . . .	167
<b>Enclosure Bezel . . . . .</b>	<b>168</b>
Removing the Enclosure Bezel . . . . .	168
Installing the Enclosure Bezel . . . . .	169
<b>Enclosure Midplane (Service Only) . . . . .</b>	<b>169</b>
Removing the Front Module Cage Assembly and Midplane . . . . .	169
Installing the Midplane and Front Module Cage Assembly . . . . .	172
<b>Enclosure Control Panel Assembly (Service Only) . . . . .</b>	<b>173</b>
Removing the Enclosure Control Panel . . . . .	173
Installing the Enclosure Control Panel . . . . .	174
<b>LCD Module . . . . .</b>	<b>175</b>
Removing the LCD Module . . . . .	175
Installing the LCD Module . . . . .	177

<b>5</b>	<b>Troubleshooting Your System</b>	<b>179</b>
	<b>Safety First—For You and Your System</b>	<b>179</b>
	<b>Start-Up Routine</b>	<b>179</b>
	<b>Checking the Equipment</b>	<b>180</b>
	<b>Troubleshooting External Connections</b>	<b>180</b>
	Troubleshooting Video	180
	Troubleshooting the Keyboard	181
	Troubleshooting the Mouse	182
	Troubleshooting USB Devices	183
	<b>Responding to a Systems Management Alert Message</b>	<b>183</b>
	<b>Troubleshooting a Wet Enclosure</b>	<b>183</b>
	<b>Troubleshooting a Damaged Enclosure</b>	<b>185</b>
	<b>Troubleshooting Enclosure Components</b>	<b>185</b>
	Troubleshooting Power Supply Modules	186
	Troubleshooting Fan Modules	186
	Troubleshooting the CMC Module	187
	Troubleshooting the iKVM Module	188
	Troubleshooting a Network Switch Module	189
	<b>Troubleshooting Blade Components</b>	<b>191</b>
	Troubleshooting Blade Memory	191
	Troubleshooting Hard Drives	192
	Troubleshooting Microprocessors	193
	Troubleshooting the Blade Board	194
	Troubleshooting the NVRAM Backup Battery	195



<b>6</b>	<b>Running System Diagnostics</b>	<b>197</b>
	<b>Using Server Administrator Diagnostics</b>	<b>197</b>
	<b>System Diagnostics Features</b>	<b>197</b>
	<b>When to Use the System Diagnostics</b>	<b>198</b>
	<b>Running the System Diagnostics</b>	<b>198</b>
	From the Utility Partition	198
	From a USB Flash Drive	198
	<b>System Diagnostics Testing Options</b>	<b>199</b>
	<b>Using the Advanced Testing Options</b>	<b>200</b>
	<b>Error Messages</b>	<b>201</b>
<b>7</b>	<b>System Board Information</b>	<b>203</b>
	<b>Blade System Board Jumper Settings</b>	<b>203</b>
	PowerEdge M905 Jumper Settings	203
	PowerEdge M805 Jumper Settings	204
	PowerEdge M600 Jumper Settings	204
	PowerEdge M605 Jumper Settings	206
	<b>System Board Connectors</b>	<b>207</b>
	PowerEdge M905 System Board	207
	PowerEdge M805 System Board	209
	PowerEdge M600 System Board	211
	PowerEdge M605 System Board	213
	<b>Disabling a Forgotten Password</b>	<b>214</b>

8 Getting Help . . . . . 217


**Contacting Dell** . . . . . **217**

Glossary 219

Index . . . . . 231

# About Your System

## Other Information You May Need

 **CAUTION:** The safety instructions that came with your system provide important safety and regulatory information. Warranty information may be included within this document or as a separate document.

- The *Rack Installation Guide* or *Rack Installation Instructions* included with your rack solution describes how to install your system into a rack.
- The *Getting Started Guide* provides an overview of system features, setting up your system, and technical specifications.
- The *Configuration Guide* provides information on initial configuration of the blades and other modular components in your system.
- The *Dell Chassis Management Controller User's Guide* and *Integrated Dell Remote Access Controller User's Guide* provides detailed information on using the remote management features of your system, including the CMC, iDRAC, and iKVM.
- User documentation for the Ethernet, Fibre Channel, Infiniband, or other I/O modules purchased with your system.
- CDs included with your system provide documentation and tools for configuring and managing your system.
- Systems management software documentation describes the features, requirements, installation, and basic operation of the software.
- Operating system documentation describes how to install (if necessary), configure, and use the operating system software.
- Documentation for any components you purchased separately provides information to configure and install these options.
- Updates are sometimes included with the system to describe changes to the system, software, and/or documentation.




**NOTE:** Always check for updates on [support.dell.com](http://support.dell.com) and read the updates first because they often supersede information in other documents.

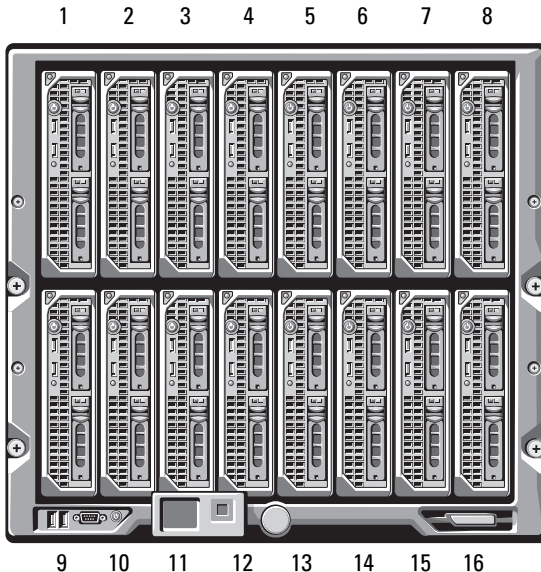
- Release notes or readme files may be included to provide last-minute updates to the system or documentation or advanced technical reference material intended for experienced users or technicians.

## System Overview

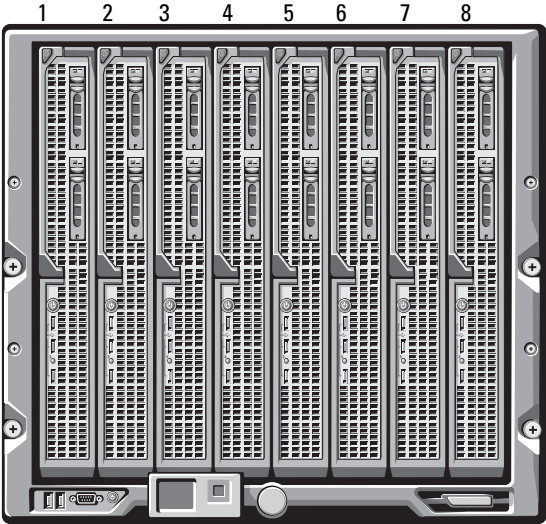
Your system can include up to 16 half-height blades (server modules), eight full-height blades, or a mixture of the two blade types (see Figure 1-1, Figure 1-2, and Figure 1-3). To function as a system, a blade is inserted into a enclosure (chassis) that supports power supplies, fan modules, a Chassis Management Controller (CMC) module, and at least one I/O module for external network connectivity. The power supplies, fans, CMC, optional iKVM module, and I/O modules are shared resources of the blades in the PowerEdge M1000e enclosure.

 **NOTE:** To ensure proper operation and cooling, all bays in the enclosure must be populated at all times with either a module or with a blank.

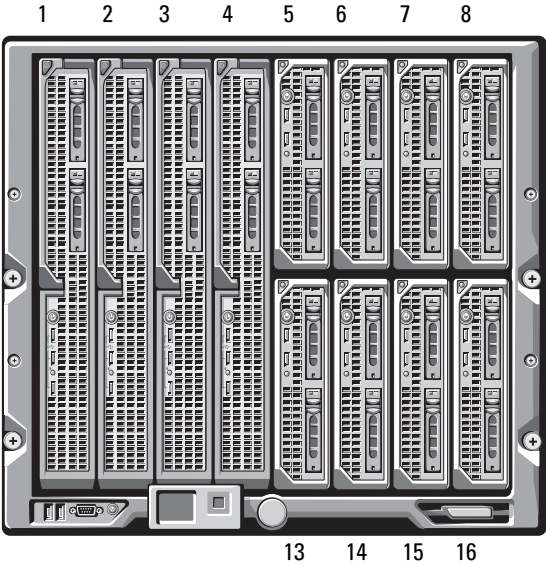
**Figure 1-1. Blade Numbering – Half-Height Blades**



**Figure 1-2. Blade Numbering - Full Height Blades**

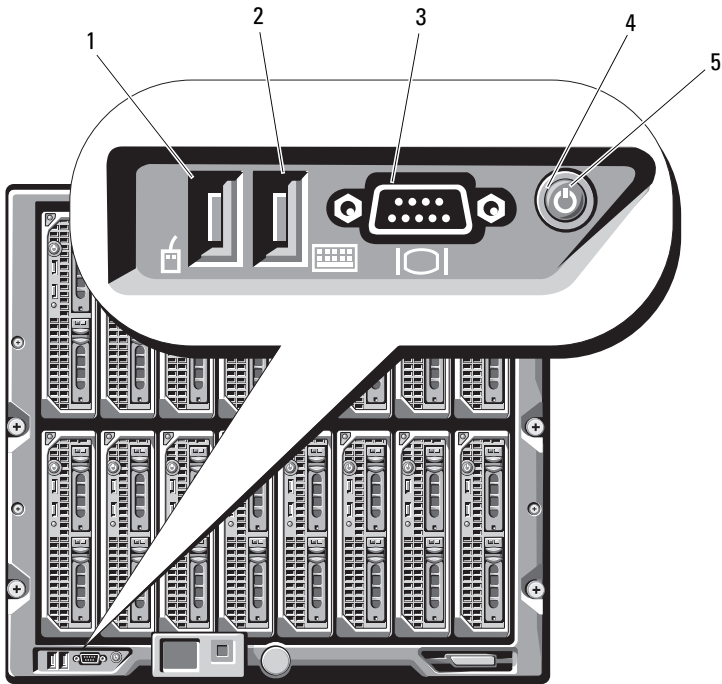


**Figure 1-3. Blade Numbering - Mixed Full-Height and Half-Height Blades**



# System Control Panel Features

Figure 1-4. Control Panel Features



1 USB port (mouse only)

2 USB port (keyboard only)

3 video connector

4 system power button

5 power indicator

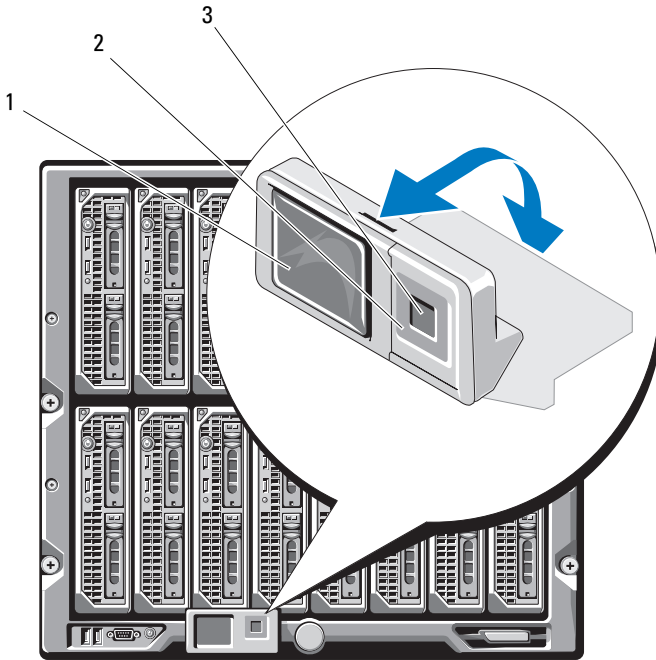
**Table 1-1. Control Panel Features**

<b>Feature</b>	<b>Indicator</b>	<b>Description</b>
System power button	N/A	Turns the system on and off. Press to turn on the system. Press and hold 10 seconds to turn off the system.  <b>NOTE:</b> The system power button controls power to all of the blades and I/O modules in the enclosure.
System power indicator	Off Green Amber	Enclosure does not have power. System power is on. Enclosure is plugged in but enclosure power is not turned on.  <b>NOTE:</b> An amber power LED does not indicate an enclosure error.
USB ports for keyboard and mouse	N/A	Functional if an optional iKVM module is installed and front panel ports are enabled (default setting) in the CMC interface.  <b>NOTE:</b> These ports do not support USB storage devices. Only connect USB storage devices to the USB ports on the front panel of the blade.
Video connector	N/A	Functional if an optional iKVM module is installed and front panel ports are enabled (default setting) in the CMC interface.

## LCD Module

The LCD module provides an initial configuration/deployment wizard, as well as easy access to infrastructure and blade information, and error reporting. See Figure 1-5.

**Figure 1-5. LCD Display**



- |   |                            |   |                    |
|---|----------------------------|---|--------------------|
| 1 | LCD screen                 | 2 | scroll buttons (4) |
| 3 | selection ("check") button |   |                    |

### **LCD Module Features**

The primary function of the LCD module is to provide real-time information on the health and status of the modules in the enclosure.

LCD module features include:

- A deployment setup wizard that allows you to configure the CMC module's network settings during initial system set up.
- Menus to configure the iDRAC in each blade.
- Status information screens for each blade.



- Status information screens for the modules installed in the back of the enclosure, including the IO modules, fans, CMC, iKVM, and power supplies.
- A network summary screen listing the IP addresses of all components in the system.
- Real time power consumption statistics, including high and low values, and average power consumption.
- Ambient temperature values.
- AC power information
- Critical failure alerts and warnings.

## Using the LCD Module Menus

Table 1-2 lists the keys that you use to view or change information on the LCD module screens.

**Table 1-2. LCD Module Screen Navigation Keys**

Keys	Action
Left and right arrows	Move between screens.
Up arrow or down arrow	Move to the previous or next option on a screen.
Center button	Select and save an item and move to the next screen.

## Configuration Wizard

When you first start up your system, you will be directed to configure the CMC network settings. The configuration wizard also automatically configures each blade's iDRAC internal network interface. The iDRAC IP addresses are incremented from the CMC IP address.





**NOTE:** After you run the configuration wizard, this option will no longer be available on the LCD menus.

- 1 Choose a language from the options presented in the dialog box.
- 2 Start the configuration wizard.

- 3 Configure the CMC network settings for your network environment:
  - Network speed
  - Duplex mode
  - Network mode (DHCP or static)
  - Static IP address, subnet mask, and gateway values (if static mode was selected)
  - DNS settings
- 4 If desired, configure the iDRAC network settings.

See the *CMC User's Guide* for detailed information about the iDRAC.

 **NOTE:** The configuration wizard will automatically configure each blade's iDRAC internal network interface if you do not choose to manually configure the iDRAC settings.

 **NOTE:** You cannot set a static IP address for the iDRAC using the LCD Configuration Wizard. To set a static IP address, use the CMC Web-based interface or RACADM.
- 5 Review the settings on the **Network Summary** screen.
  - If the settings are correct, press the center button to close the configuration wizard and return to the **Main Menu**.
  - If the settings are not correct, use the left arrow key to return to the screen for that setting and correct it.

After you complete the configuration wizard, the CMC will be available on your network.

## **Main Menu**

The Main Menu options include links to the **Server Menu**, the **Enclosure Menu**, and the **LCD Setup Menu**.

## **LCD Setup Menu**

You can change the default language and startup screen for the LCD menu screens using this menu.

## Server Menu

From the **Server Menu** dialog box, you can highlight each blade in the enclosure using the arrow keys, and view its status.

- A blade that is powered off or booting is designated by a gray rectangle. An active blade is indicated by a green rectangle. If a blade has errors, this condition is indicated by an amber rectangle.
- To select a blade, highlight it and press the center button. A dialog box displays the iDRAC IP address of the blade and any errors present.

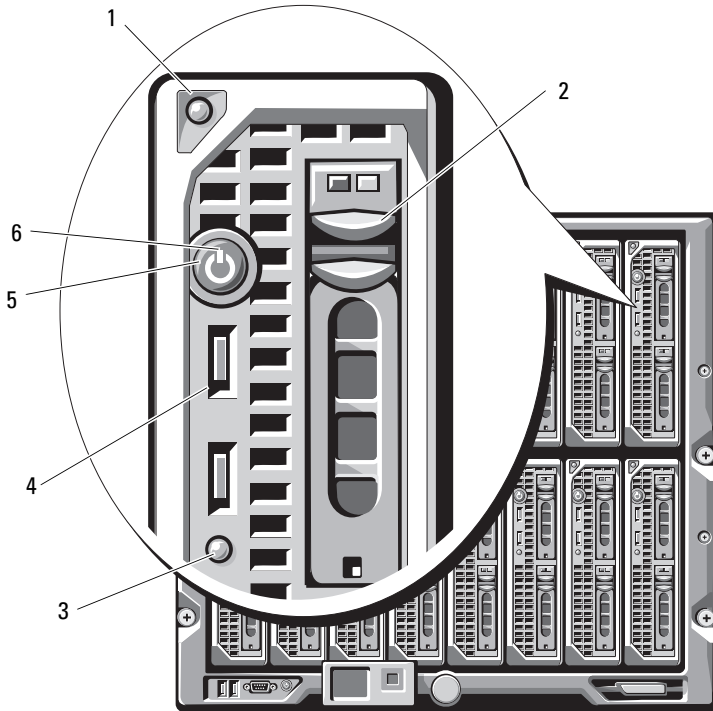
## Enclosure Menu

The **Enclosure Menu** includes options for **Module Status**, **Enclosure Status**, and **Network Summary**.

- In the **Module Status** dialog box, you can highlight each component in the enclosure and view its status.
  - A module that is powered off or booting is designated by a gray rectangle. An active module is indicated by a green rectangle. If a module has errors, it will be indicated by an amber rectangle.
  - If a module is selected, a dialog box displays the current status of the module and any errors present.
- In the **Enclosure Status** dialog box, you can view the enclosure status, any error conditions, and power consumption statistics.

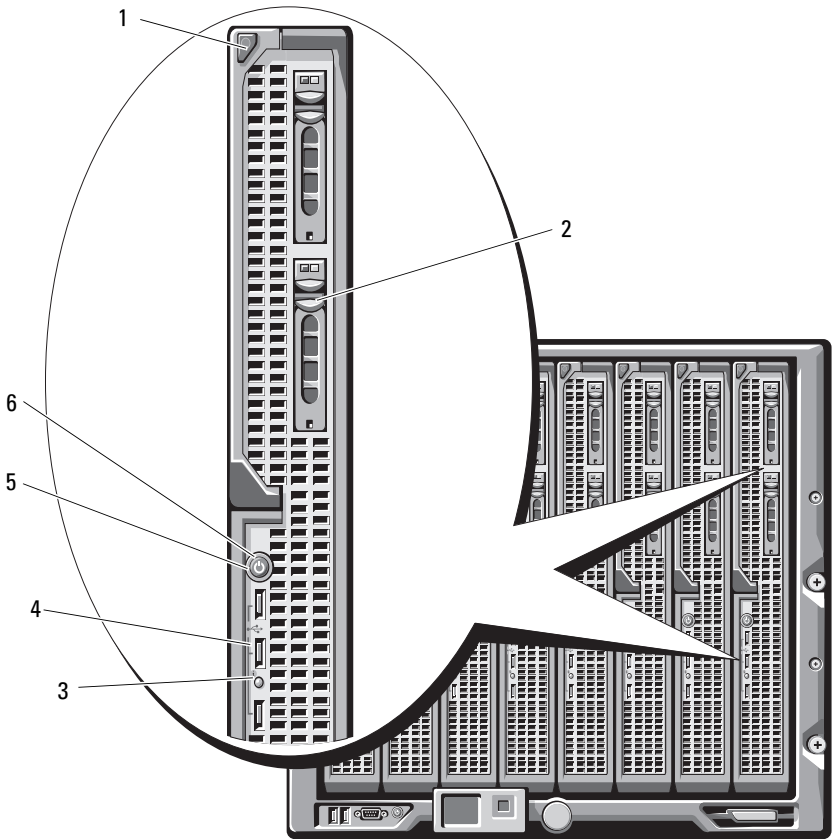
# Blade Features

Figure 1-6. Front Panel Features - PowerEdge M600 and M605






- |   |                                       |   |                       |
|---|---------------------------------------|---|-----------------------|
| 1 | blade handle release button           | 2 | hard drives (2)       |
| 3 | blade status/identification indicator | 4 | USB connectors (2)    |
| 5 | blade power button                    | 6 | blade power indicator |

**Figure 1-7. Front Panel Features - PowerEdge M905 and M805**




- |   |                                       |   |                       |
|---|---------------------------------------|---|-----------------------|
| 1 | blade handle release button           | 2 | hard drives (2)       |
| 3 | blade status/identification indicator | 4 | USB connectors (3)    |
| 5 | blade power button                    | 6 | blade power indicator |


**Table 1-3. Blade Control Panel Features**

Feature	Icon	Description
Blade power indicator		<p>Off – Power is not available to the blade, the blade is in standby mode, the blade is not turned on, or the blade is installed incorrectly. For detailed information on installing a blade, see "Installing a Blade" on page 98.</p> <p>Green increasing from low brightness to full brightness – Blade power on request is pending.</p> <p>Green on – The blade is turned on.</p>
Blade status/identification indicator		<p>Off – The blade power is off.</p> <p>Blue – Normal operating state</p> <p>Blue blinking – The blade is being remotely identified via the CMC.</p> <p>Amber blinking – Blade has either detected an internal error, or the installed mezzanine card(s) does not match the I/O modules installed in the M1000e enclosure. Check the CMC for an I/O configuration error message and correct the error.</p>
Blade power button	N/A	<p>Turns blade power off and on.</p> <ul style="list-style-type: none"><li>• If you turn off the blade using the power button and the blade is running an ACPI-compliant operating system, the blade can perform an orderly shutdown before the power is turned off.</li><li>• If the blade is not running an ACPI-compliant operating system, power is turned off immediately after the power button is pressed.</li><li>• Press and hold the button to turn off the blade immediately.</li></ul> <p>The blade power button is enabled by default by the System Setup program.(If the power button option is disabled, you can only use the power button to turn on the blade. The blade can then only be shut down using system management software.)</p>
USB connector		Connects external USB 2.0 devices to the blade.

## Using USB Diskette or USB DVD/CD Drives

Each blade has USB ports on the front of the blade which allows you to connect a USB diskette drive, USB flash drive, USB DVD/CD drive, keyboard, or mouse. (PowerEdge M905 and M805 blades have three USB ports; PowerEdge M605 and M600 blades have two ports.) The USB drives can be used to configure the blade.

 **NOTICE:** The system supports only Dell-branded USB 2.0 drives. The drive must be horizontal and level to operate properly. Use the optional external drive storage tray to support the drive while in use.


 **NOTE:** If the drive must be designated as the boot drive, connect the USB drive, restart the system, then enter the System Setup Program and set the drive as first in the boot sequence (see "Using the System Setup Program" on page 79). The USB device will be displayed in the boot order setup screen only if it is attached to the system before you run the System Setup program.

You can also select the boot device by pressing the <F11> key during system startup and selecting a boot device for the current boot sequence.

## Hard-Drive Features

- The PowerEdge M805 and M905 blades support one or two hot-pluggable 2.5 inch SAS hard drives.
- The PowerEdge M600 and M605 blades support one or two hot-pluggable 2.5-inch SATA hard drives *or* one or two 2.5 inch SAS hard drives.


 **NOTE:** SAS and SATA hard drives cannot be mixed within a blade.

 **NOTE:** SATA hard drives are not hot pluggable with the SATA repeater daughter card.

Hot-plug drive operation is supported if an optional RAID controller card is installed in the blade.

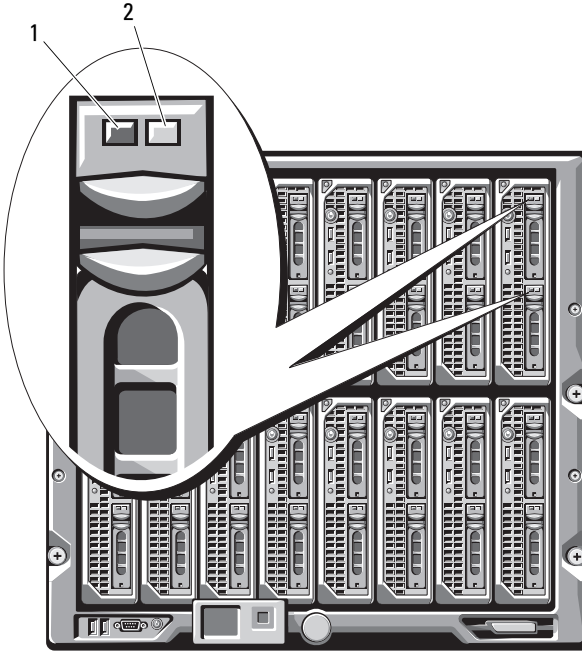
On blades with a diskless configuration, no disk controller is included in the blade, but hard-drive blanks and the internal storage backplane must be present to maintain proper airflow.

See Figure 1-8 and Table 1-4 for information on the hard-drive indicators. Different patterns are displayed as drive events occur in the system.

 **NOTICE:** The blade must have a hard drive or a hard-drive blank installed in each hard-drive bay.

**NOTE:** The hard-drive status indicator is only functional for RAID hard drive configurations. For non-RAID configurations, only the drive-activity indicator is active. Refer to the Dell RAID controller documentation to service a RAID volume, rebuild an array, or swap RAID members.

**Figure 1-8. Hard-Drive Indicators**



1 activity indicator

2 status indicator (RAID drives only)

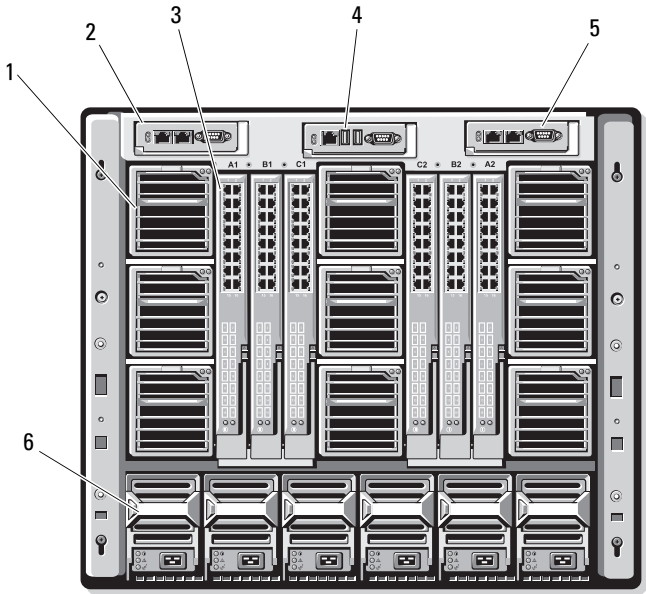


**Table 1-4. Hard-Drive Indicator Patterns**

<b>Indicator</b>	<b>State</b>	<b>Description</b>
Activity indicator	Off	Drive is not being accessed
	On	Drive is being accessed
Status indicator (SAS drives with optional RAID controller only)	Off	<ul style="list-style-type: none"><li>• Drive is ready for removal.</li><li>• Drive bay is empty.</li><li>• Power is off to the blade.</li></ul>
	Green	Drive is online.
	Green, blinking slowly	Drive is rebuilding.
	Green, blinking quickly	Drive is being identified.
	Amber	Drive has failed or has an error. See "Troubleshooting Hard Drives" on page 192.
	Amber blinking slowly, Green blinking slowly, then off	The drive has reported a predictive failure event, and should be replaced.

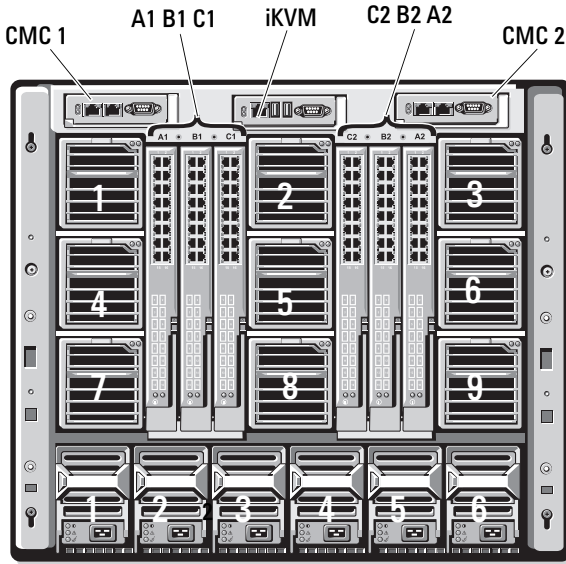
# Back-Panel Features

Figure 1-9. Back-Panel Features



- |   |                      |   |                      |
|---|----------------------|---|----------------------|
| 1 | fan modules (9)      | 2 | primary CMC module   |
| 3 | I/O modules (6)      | 4 | optional iKVM module |
| 5 | secondary CMC module | 6 | power supplies (6)   |

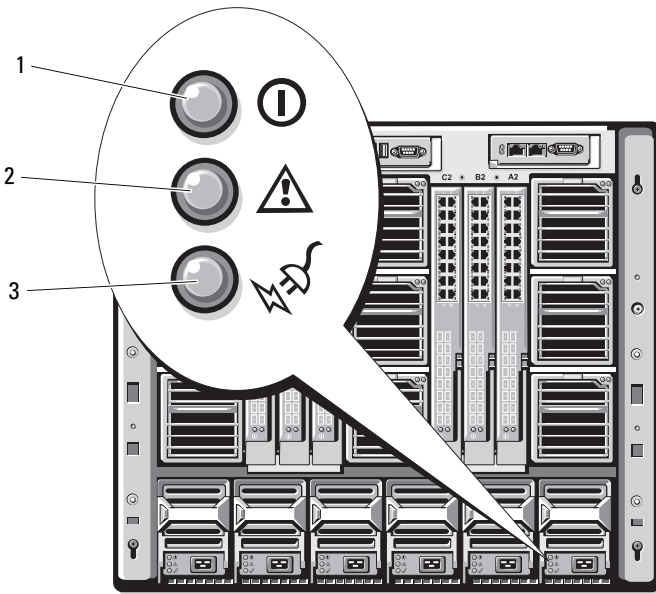
**Figure 1-10. Back-Panel Module Bay Numbering**



## Power Supply Indicator

- ➡ **NOTICE:** The power supplies must be connected to a PDU, not directly to an electrical outlet. The power supplies require a 200–240 V power source.

**Figure 1-11. Power Supply Indicators**




- 1 DC power output indicator
- 2 power supply fault indicator
- 3 AC power present indicator

**Table 1-5. Power Supply Indicators**

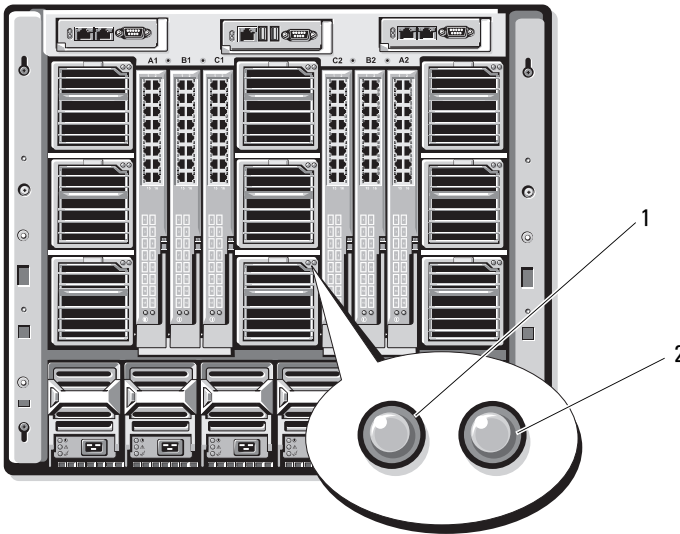
Indicator	Icon	Indicator Color	Description
DC power output good		Green	The power supply is operational and DC power is being supplied by the power supply.
Fault indicator		Amber	The power supply is in a fault condition, which can result from either a failed power supply or a failed fan within the power supply. See "Power Supply Modules" on page 158.

**Table 1-5. Power Supply Indicators (continued)**

Indicator	Icon	Indicator Color	Description
AC power source present indicator		Green	The power supply is connected to an 208VAC AC power source. <b>NOTE:</b> This indicator will not illuminate if the power supply is connected to a 110 VAC power source.

## Fan Module Indicators

**Figure 1-12. Fan Module Indicators**



1 fan power indicator

2 fan fault indicator

**Table 1-6. Fan Indicators**

<b>Indicator</b>	<b>Indicator State</b>	<b>Description</b>
Power indicator	Green	The power supply is connected to an 208VAC AC power source. <b>NOTE:</b> This indicator will not illuminate if the power supply is connected to a 110 VAC power source.
	Off	AC power not connected.
Fault indicator	Amber	The fan is in a fault condition.
	Off	Fan not faulty.

## iKVM Module

The optional Avocent iKVM analogue switch module includes the following features:

- Local iKVM access can be remotely disabled on a per blade basis, using the blade's iDRAC interface (access is enabled by default).



**NOTE:** By default (enabled), a console session to a given blade will be available to both the iDRAC interface and iKVM (users connected to a blade's console via iDRAC and the iKVM will see the same video and be able to type commands). If this sharing is not desired, this can be disabled via the iDRAC console interface.

- The following connectors:
  - One VGA connector. The iKVM supports a video display resolution range from 640x480 at 60Hz up to 1280x1024x65,000 colors (noninterlaced) at 75Hz.
  - Two USB ports for keyboard and mouse.



**NOTE:** The iKVM USB ports do not support storage devices.

- RJ-45 ACI port for tiering with Dell and Avocent analog KVM and KVM over IP switches with ARI ports.



**NOTE:** Although the ACI port is an RJ-45 connector and uses Cat5 (or better) cabling, it is not an Ethernet network interface port. It is only used for connection to external KVM switches with Analog Rack Interface (ARI) ports, and does not support native KVM over IP.

- The iKVM can also be accessed from the front of the enclosure, providing front or rear panel KVM functionality, but not at the same time. For enhanced security, front panel access can be disabled using the CMC's interface.

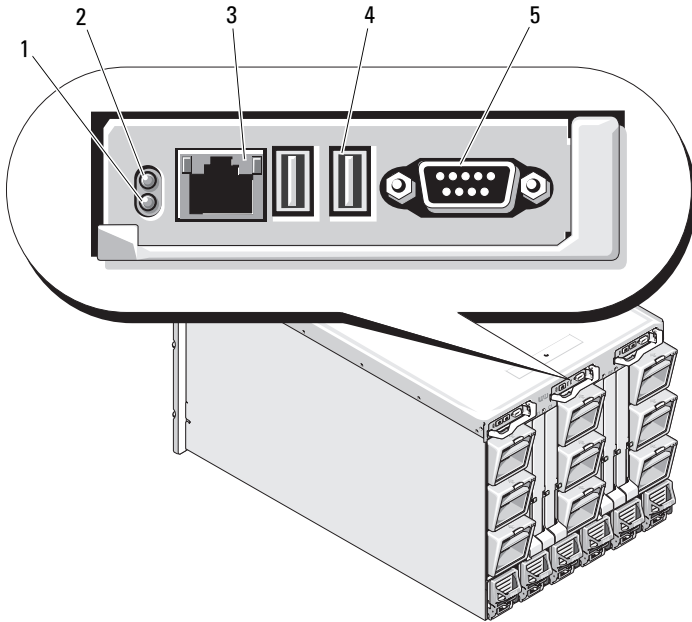


**NOTE:** Connecting a keyboard, video, and mouse to the enclosure front panel will disable video output to the iKVM back panel port. It will not interrupt iDRAC video and console redirection.

- You can use the iKVM to access the CMC console directly, using RACADM or via the Web-based interface. For more information, see "Using the iKVM Module" in the CMC *User's Guide*.

Figure 1-13 shows the external features of the iKVM switch module.

**Figure 1-13. Avocent iKVM Switch Module**



- |   |                                      |   |   |
|---|--------------------------------------|---|---|
| 1 | identification indicator             | 2 | status indicator                          |
| 3 | ACI port for tiering connection only | 4 | USB connectors (2) for keyboard and mouse |
| 5 | video connector                      |   |   |

**NOTE:** Do not connect the ACI port to a LAN device such as a network hub. Doing so may result in equipment damage.



**Table 1-7. Avocent Analog iKVM Switch Module Features**

<b>Feature</b>	<b>Indicator Pattern</b>	<b>Description</b>
Power indicator	Off	iKVM switch does not have power.
	Green	iKVM switch has power.
	Green flashing	Firmware upgrade in progress
Status/identification indicator	Blue blinking	iKVM module is being identified.
	Amber flashing	System fault or error condition.
USB connectors	Allows a keyboard and mouse to be connected to the system.	
Video connector	Allows a monitor to be connected to the system.	
ACI port	Allows connection of one or more servers to a Dell console switch with an Analog Rack Interface (ARI) port, such as an external digital or analog switch.	
Link indicator	Off	The ACI is not connected to the external switch.
	Green	The ACI is connected to the external switch.
Activity indicator	Off	Data is not being sent or received.
	Amber blinking	Data is being sent or received.

### **Tiering the Avocent iKVM Switch From a Analog KVM Switch**

The Avocent iKVM switch can be tiered from analog KVM switches such as the Dell 2160AS and 180AS, as well as many Avocent analog KVM switches. Many switches may be tiered without the need for a Server Interface Pod (SIP) (see Table 1-8).

**Table 1-8. Cabling Requirements for External Analog KVM Switches**

<b>Switch</b>	<b>Tiering Cabling Requirements</b>
Dell PowerConnect 180AS, 2160AS	Seamless tiering using ACI port and Cat 5 cable
Avocent Autoview 1400, 1500, 2000, 2020, 2030, Ax000R	

**Table 1-8. Cabling Requirements for External Analog KVM Switches (continued)**

Switch	Tiering Cabling Requirements
Avocent Autoview 200, 400, 416, 424	Dell USB SIP required with Cat 5 cable
Avocent Outlook 140ES, 180ES, 160ES	

Before connecting the iKVM switch to a supported analog switch, you must set the iKVM switch to display in slot order, and set the **Screen Delay Time** to 1 or more seconds:

- 1 Press <Print Screen> to launch the iKVM Switch OSCAR.
- 2 Click **Setup > Menu**. The **Menu** dialog box appears.
- 3 Select **Slot** to display servers numerically by slot number.
- 4 Enter a screen delay time of at least 1 second.
- 5 Click **OK**.

Setting the Screen Delay time to 1 second allows you to soft switch to a server without launching OSCAR.



**NOTE:** Soft switching allows you to switch servers using a hot key sequence. You can soft switch to a server by pressing <Print Screen> and then typing the first few characters of its name or number. If you have a Delay Time set and you press the key sequences before that time has elapsed, OSCAR will not display.

To configure the analog switch:

- 1 Press <Print Screen> to open the OSCAR **Main** dialog box.
- 2 Click **Setup → Devices → Device Modify**.
- 3 Select the 16-port option to match the number of blades in your system.
- 4 Click **OK** to exit OSCAR.
- 5 Press <Print Screen> to verify that the settings have taken effect. The slot number of the blade to which the iKVM switch is now attached should be expanded to display each of the slot locations of the blades in the system. For instance, if the iKVM switch is attached to slot 1, it would now be displayed as 01-01 to 01-16.

To connect the Avocent iKVM switch to a supported analog switch:

- 1 If the switch does not require a SIP to connect to the iKVM (see Table 1-8), connect a Cat5 (or newer) cable to the RJ-45 ACI port on the iKVM module. See Figure 1-13.

Connect the other end of this cable to the ARI port on the external switch.

If the analog switch requires a USB SIP (see Table 1-8), connect a USB SIP to the iKVM, then connect a Cat5 (or newer) cable to the SIP. Connect the other end of this cable to the ARI port on the external switch.

- 2 Connect both the analog switch and the system to an appropriate power source.
- 3 Power up the system.
- 4 Power up the external analog switch.



**NOTE:** If the external analog switch is powered up before the system, it may result in only one blade displaying in the analog switch OSCAR, instead of 16. If this behavior occurs, shut down and restart the switch so the entire complement of blades is recognized.



**NOTE:** In addition, to the steps outlined above, some external analog switches may require you to perform additional steps to ensure that the iKVM switch blades appear in the external analog switch OSCAR. See the external analog switch documentation for additional information.

## Tiering the Avocent iKVM Switch From a Digital KVM Switch

The iKVM switch may also be tiered from a digital KVM switch such as the Dell 2161DS or 4161DS, or a supported Avocent digital KVM switch. Many switches may be tiered without the need for a SIP (see Table 1-9).

**Table 1-9. Cabling Requirements for External Digital KVM Switches**

Switch	Tiering Requirements
Dell PowerConnect 2161DS, 4161DS	Seamless tiering using ACI port and Cat 5 cable
Avocent DSR 800, x16x, x010, x031, x030, x035, 102x (except 1024)	
Avocent DSR 1024	Dell USB SIP required with Cat 5 cable

To tier the iKVM switch module from a Dell 2161DS, 180AS, or 2160AS console switch:

- *If the switch does not require a SIP to connect to the iKVM (see Table 1-9), connect a Cat5 (or newer) cable to the RJ-45 ACI port on the iKVM module. See Figure 1-13.*

Connect the other end of this cable to the ARI port on the external switch.

- *If the switch requires a USB SIP (see Table 1-8), connect a USB SIP to the iKVM, then connect a Cat5 (or newer) cable to the SIP. Connect the other end of this cable to the ARI port on the external switch.*

Once the KVM switch is connected, the server modules appear in OSCAR.



**NOTE:** Once the local system is set up, you must also resynchronize the server list from the Remote Console Switch software in order to see the list of blades. See *Resynchronizing the Server List at the Remote Client Workstation*.

### Resynchronizing the Server List at the Remote Client Workstation

Once the iKVM switch is connected, the blades appear in OSCAR. You now need to resynchronize the servers on any remote workstation to ensure that the blades are available to any remote users connected to the console switch through the Remote Console Switch software.



**NOTE:** This procedure only resynchronizes one remote client workstation. With multiple client workstations, save the resynchronized local database and load it into the other client workstations to ensure consistency.

To resynchronize the server listing:

- 1 Click **Resync** in the **Server** category of the Management Panel (MP).  
The Resync Wizard launches.

- 2 Click **Next**.

A warning message displays indicating that the database will be updated to match the current configuration of the console switch. Your current local database names will be overridden with the switch names. To include unpowered SIPs in the resynchronization, click to enable the **Include Offline SIPs** check box.

- 3 Click **Next**.

A **Polling Remote Console Switch** message box appears with a progress bar indicating that the switch information is being retrieved.

**4** If no changes were detected in the appliance, a completion dialog box appears with this information.

If server changes were detected, then the **Detected Changes** dialog box will be displayed. Click **Next** to update the database.

**5** If a cascade switch was detected, the **Enter Cascade Switch Information** dialog box appears. Select the type of switch connected to the appliance from the drop-down list. If the type you are looking for is not available, you can add it by clicking **Add**.

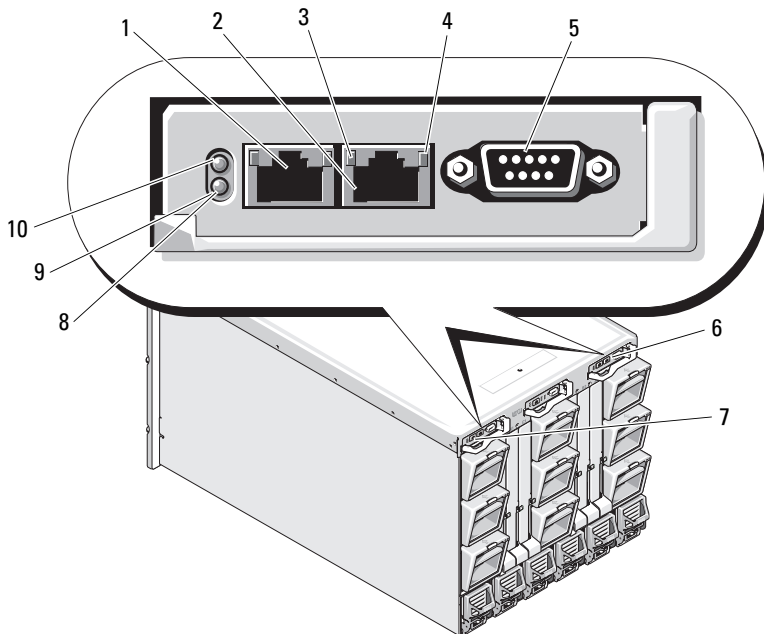
**6** Click **Next**. The completion dialog box appears.

**7** Click **Finish** to exit.

**8** Start up the analog switch and the system.

# CMC Module

Figure 1-14. CMC Module Features



- |   |   |    |  |
|---|---|----|--|
| 1 | Ethernet connector Gb1                        | 2  | Ethernet connector STK ("stack") - used for daisy-chaining CMCs in separate enclosures |
| 3 | link indicator (2)                            | 4  | activity indicator (2)   |
| 5 | DB-9 serial connector for local configuration | 6  | optional secondary CMC (CMC 2)   |
| 7 | primary CMC (CMC 1)                           | 8  | amber fault indicator  |
| 9 | blue status/identification indicator          | 10 | power indicator  |

**Table 1-10. CMC Module Features**

<b>Indicator</b>	<b>Pattern</b>	<b>Description</b>
Network interface controller link indicator	Off	LAN is not linked.
	Green	LAN is linked.
Network interface controller activity indicator	Off	LAN is not active.
	Amber blinking	Indicates that the system CMC and the LAN are communicating.
Power indicator	Off	CMC does not have power.
	Green	CMC has power.
	Green blinking	Firmware update in progress
Status/identification indicator	Off	This CMC is the standby CMC.
	Blue (solid)	This CMC is the primary CMC.
	Blue (blinking)	The CMC is being identified by the systems management software.
Fault indicator	Off	The CMC is operating normally.
	Amber blinking	A fault has occurred.
Serial connector	None	Used for local configuration (115200 baud, No parity, 8, 1)

The CMC provides multiple systems management functions for your modular server:

- Enclosure-level real-time automatic power and thermal management.
  - The CMC monitors system power requirements and supports the optional Dynamic Power Supply Engagement mode so that the CMC can enable or place power supplies in standby dynamically depending on load and redundancy requirements to improve power efficiency.
  - The CMC reports real-time power consumption, which includes logging high and low points with a time stamp.

- The CMC supports setting an optional enclosure Maximum Power Limit, which will either alert or take actions, such as throttling server modules and/or preventing the power up of new blades to keep the enclosure under the defined maximum power limit.
- The CMC monitors and automatically controls cooling fans based on actual ambient and internal temperature measurements.
- The CMC provides comprehensive enclosure inventory and status/error reporting.
- The CMC provides a mechanism for centralized configuration of the following:
  - The M1000e enclosure's network and security settings
  - Power redundancy and power ceiling settings
  - I/O switches and iDRAC network settings
  - First boot device on the server blades
  - The CMC checks I/O fabric consistency between the I/O modules and blades and disables components if necessary to protect the system hardware.
  - User access security.

The CMC has two Ethernet ports: Gb1 is used to connect to the external management network. The connector labeled STK ("stack") will allow CMCs in adjacent enclosures to be daisy-chained. A 24-port Ethernet switch provides internal communication between the iDRAC on each blade, I/O modules, optional KVM, and optional second, redundant CMC.



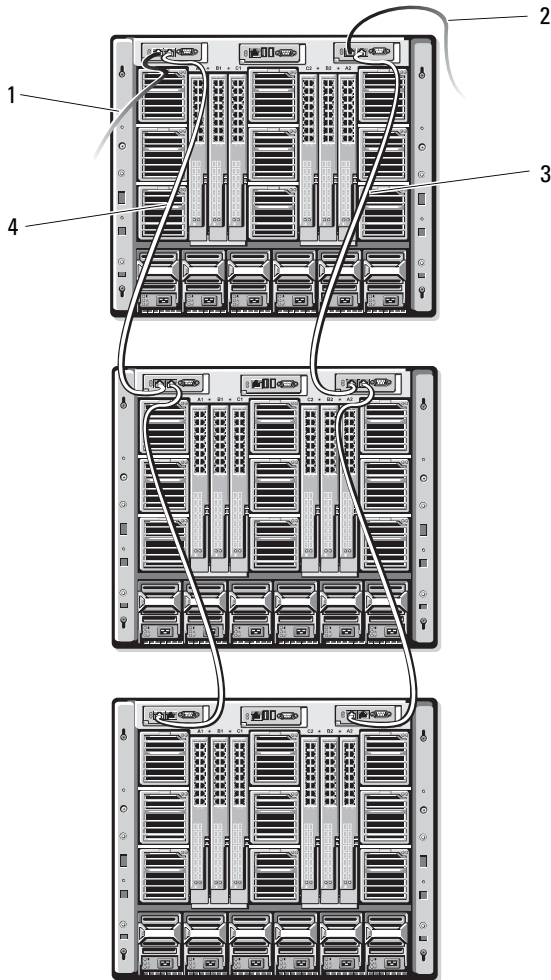
**NOTE:** The 24-port Ethernet switch is reserved for internal communication between the iDRAC on the blades to the CMC and the external management network. If two CMCs are installed, the heartbeat for CMC redundancy is also present and CMC redundancy is supported over this internal network. This internal network is outside the data path from host LOMs and the mezzanine cards in the blades.

At least one CMC must be installed in the primary CMC bay (see Figure 1-14) for the system to power up. If a second, optional CMC module is installed, failover protection and hot-plug replacement is available.

See the latest *Dell Chassis Management Controller User's Guide* at [support.dell.com](http://support.dell.com) for complete instructions on how to set up and operate the CMC module.



**Figure 1-15. CMC Daisy-Chaining**



- |   |  |   |  |
|---|--|---|--|
| 1 | CMC1 – cable from connector Gb1 to network                                   | 2 | CMC2 – cable from connector Gb1 to network                                   |
| 3 | CMC2 – cable from connector STK to connector Gb1 on CMC2 in adjacent chassis | 4 | CMC1 – cable from connector STK to connector Gb1 on CMC1 in adjacent chassis |

## I/O Connectivity

The M1000e enclosure supports three layers of I/O fabric, selectable between combinations of Ethernet, Infiniband, and fibre-channel modules. (Additional fabrics including 10 Gb Ethernet will be supported in the future.) You can install up to six hot-swappable I/O modules in the enclosure, including fibre-channel switches, fibre-channel pass-throughs, Infiniband switches, Ethernet switches, and Ethernet pass-through modules.

### Guidelines for Installing I/O Modules

You must follow these guidelines when populating I/O modules. See Figure 1-9 for the I/O bay locations.

#### General I/O Module Configuration Guidelines

- If an I/O module is installed in Fabric B or Fabric C, at least one blade must have a matching mezzanine card installed to support data flow for that I/O module.
- If a blade has an optional mezzanine card installed in a Fabric B or Fabric C card slot, at least one corresponding I/O module must be installed to supported data flow for that fabric
- Within each fabric type, you must install a module in the fabric's channel 1 slot before installing a module in the fabric's channel 2 slot. For example, you must install a module in slot C1 before installing a module in slot C2.
- Modules may be installed in Fabrics B and C independently (you do not need to install modules in Fabric B before installing modules in the Fabric C slots.)
- Slots A1 and A2 only support Ethernet I/O modules. This fabric type is hard-set to Ethernet for these slots and cannot support Fibre Channel, Infiniband, or other fabric type modules.
- Slots A, B, and C can support Ethernet fabric-type modules.
- To enable switch configuration prior to blade imaging, I/O modules are allowed to power-up before a blade is inserted in the enclosure.

## Fabric A

Fabric A is a redundant Gb Ethernet fabric, supporting I/O module slots A1 and A2. The integrated Ethernet controllers in each blade dictate Fabric A as an Ethernet-only fabric.



**NOTICE:** Modules designed for Fabric B or Fabric C cannot be installed in slots A1 or A2.

## Fabric B

Fabric B is a 1 to 10 Gb/sec dual port, quad-lane redundant fabric, supporting I/O module slots B1 and B2. Fabric B currently supports Gb Ethernet, Infiniband, and Fibre Channel modules. Additional fabric types including 10 Gb Ethernet will be supported in the future.

To communicate with an I/O module in the Fabric B slots, a blade must have a matching mezzanine card installed in a Fabric B mezzanine card location.

Modules designed for Fabric A may also be installed in the Fabric B slots.

## Fabric C

Fabric C is a 1 to 10 Gb/sec dual port, quad-lane redundant fabric, supporting I/O module slots C1 and C2. Fabric C currently supports Gb Ethernet, Infiniband, and Fibre Channel modules. Additional fabric types including 10 Gb Ethernet will be supported in the future.

To communicate with an I/O module in the Fabric C slots, a blade must have a matching mezzanine card installed in a Fabric C mezzanine card location.

Modules designed for Fabric A may also be installed in the Fabric C slots.

## Mezzanine Cards

### PowerEdge M905 and M805

The full-height PowerEdge M905 and M805 blades support four mezzanine cards:

- Slot Mezz1\_Fabric\_C and slot Mezz3\_Fabric\_C support Fabric C. If a card is installed in both slots, both cards must be identical. They must also match the fabric type of the I/O modules installed in I/O module bays C1 and C2.

- Slot Mezz2\_Fabric\_B and slot Mezz4\_Fabric\_B support Fabric B. If a card is installed in both slots, both cards must be identical. They must also match the fabric type of the I/O modules installed in I/O module bays B1 and B2.

### PowerEdge M600 and M605

The half-height PowerEdge M600 and M605 blades support two mezzanine cards:

- Mezzanine card slot C supports Fabric C. This card must match the fabric type of I/O modules installed in I/O module bays C1 and C2.
- Mezzanine card slot B supports Fabric B. This card must match the fabric type of I/O modules installed in I/O module bays B1 and B2.

See "I/O Module Mezzanine Cards" on page 123 for more information on mezzanine cards.

Table 1-11 shows various supported combinations of mezzanine cards and I/O modules.

**Table 1-11. Supported I/O Module Configurations**

<b>Fabric A</b>	<b>Fabric B Mezzanine Card</b>	<b>Fabric C Mezzanine Card</b>	<b>I/O Bay A1, A2</b>	<b>I/O Bay B1, B2</b>	<b>I/O Bay C1, C2</b>
Standard Integrated LOM NIC	none	none	Ethernet switch module or pass-through module	none	none
Standard Integrated LOM NIC	Ethernet mezzanine card	none	Ethernet switch module or pass-through module	Ethernet switch module or pass-through module	none
Standard Integrated LOM NIC	none	Infiniband mezzanine card	Ethernet switch module or pass-through module	none	Infiniband switch module

**Table 1-11. Supported I/O Module Configurations (continued)**

<b>Fabric A</b>	<b>Fabric B Mezzanine Card</b>	<b>Fabric C Mezzanine Card</b>	<b>I/O Bay A1, A2</b>	<b>I/O Bay B1, B2</b>	<b>I/O Bay C1, C2</b>
Standard Integrated LOM NIC	Ethernet mezzanine card	Ethernet mezzanine card	Ethernet switch module or pass-through module	Ethernet switch module or pass-through module	Ethernet switch module or pass-through module
Standard Integrated LOM NIC	Fibre Channel mezzanine card	Infiniband mezzanine card	Ethernet switch module or pass-through module	Fibre Channel switch or pass-through module	Infiniband switch module
Standard Integrated LOM NIC	none	Fibre Channel mezzanine card	Ethernet switch module or pass-through module	none	Fibre Channel switch module or pass-through module
Standard Integrated LOM NIC	Fibre Channel mezzanine card	Fibre Channel mezzanine card	Ethernet switch module or pass-through module	Fibre Channel switch or pass-through module	Fibre Channel switch or pass-through module
Standard Integrated LOM NIC	Ethernet mezzanine card	Fibre Channel mezzanine card	Ethernet switch module or pass-through module	Ethernet switch module or pass-through module	Fibre Channel switch or pass-through module
Standard Integrated LOM NIC	Infiniband mezzanine card	Infiniband mezzanine card	Ethernet switch module or pass-through module	Infiniband switch module	Infiniband switch module

**Table 1-11. Supported I/O Module Configurations (continued)**

<b>Fabric A</b>	<b>Fabric B Mezzanine Card</b>	<b>Fabric C Mezzanine Card</b>	<b>I/O Bay A1, A2</b>	<b>I/O Bay B1, B2</b>	<b>I/O Bay C1, C2</b>
Standard Integrated LOM NIC	Fibre Channel mezzanine card	Ethernet mezzanine card	Ethernet switch module or pass-through module	Fibre Channel switch or pass-through module	Ethernet switch module or pass-through module

### **I/O Module Port Mapping**

The integrated LOMs and optional mezzanine cards are mapped to the I/O module ports based on the following rules:

#### **Full-Height Blades (PowerEdge M905 and M805)**

Each LOM or mezzanine card has two port connections. For a full-height blade in bay *n*:

- Integrated NIC LOM1, connection 1 will connect to I/O module A1, port *n*. Integrated NIC LOM1, connection 2 will connect to I/O module A2, port *n*.
- Integrated NIC LOM2, connection 1 will connect to I/O module A1, port *n*+8. Integrated NIC LOM2, connection 2 will connect to I/O module A2, port *n*+8.
- Mezzanine card 1, connection 1 will connect to I/O module C1, port *n*. Mezzanine card 1, connection 2 will connect to I/O module C2, port *n*.
- Mezzanine card 2, connection 1 will connect to I/O module B1, port *n*. Mezzanine card 2, connection 2 will connect to I/O module B2 port *n*.
- Mezzanine card 3, connection 1 will connect to I/O module C1, port *n*+8. Mezzanine card 3, connection 2 will connect to I/O module C2 port *n*+8.
- Mezzanine card 4, connection 1 will connect to I/O module B1, port *n*+8. Mezzanine card 4, connection 2 will connect to I/O module B2 port *n*+8.

For example, in a full-height blade in slot 5, integrated NIC LOM1 connection 1 will connect to I/O module A1, port 5 and LOM1 connection 2 will connect to I/O module A2 port 5. NIC LOM2 connection 1 will connect to I/O module A1, port 13 and LOM2 connection 2 will connect to I/O

module A2, port 13. Mezzanine card 3, connection 1 will connect to I/O module C1, port 13 and Mezzanine card 3, connection 2 will connect to I/O module C2 port 13. Table 1-12 shows the port number assignments for the eight possible full height blade locations.

**Table 1-12. I/O Module Port Assignments - Full-Height Blades**

<b>Blade 1</b>	<b>I/O Module</b>					
	<b>A1</b>	<b>C1</b>	<b>A1</b>	<b>C2</b>	<b>B2</b>	<b>A2</b>
Integrated LOM1	Port 1					Port 1
Integrated LOM2	Port 9					Port 9
Mezz1_Fab_C			Port 1	Port 1		
Mezz2_Fab_B		Port 1			Port 1	
Mezz3_Fab_C			Port 9	Port 9		
Mezz4_Fab_B		Port 9			Port 9	

<b>Blade 2</b>	<b>I/O Module</b>					
	<b>A1</b>	<b>B1</b>	<b>C1</b>	<b>C2</b>	<b>B2</b>	<b>A2</b>
Integrated LOM1	Port 2					Port 2
Integrated LOM2	Port 10					Port 10
Mezz1_Fab_C			Port 2	Port 2		
Mezz2_Fab_B		Port 2			Port 2	
Mezz3_Fab_C			Port 10	Port 10		
Mezz4_Fab_B		Port 10			Port 10	

<b>Blade 3</b>	<b>I/O Module</b>					
	<b>A1</b>	<b>B1</b>	<b>C1</b>	<b>C2</b>	<b>B2</b>	<b>A2</b>
Integrated LOM1	Port 3					Port 3
Integrated LOM2	Port 11					Port 11
Mezz1_Fab_C			Port 3	Port 3		
Mezz2_Fab_B		Port 3			Port 3	

<b>Blade 3</b>	<b>I/O Module</b>					
	<b>A1</b>	<b>B1</b>	<b>C1</b>	<b>C2</b>	<b>B2</b>	<b>A2</b>
Mezz3_Fab_C			Port 11	Port 11		
Mezz4_Fab_B		Port 11			Port 11	

<b>Blade 4</b>	<b>I/O Module</b>					
	<b>A1</b>	<b>A1</b>	<b>A1</b>	<b>C2</b>	<b>C2</b>	<b>C2</b>
Integrated LOM1	Port 4					Port 4
Integrated LOM2	Port 12					Port 12
Mezz1_Fab_C			Port 4	Port 4		
Mezz2_Fab_B		Port 4			Port 4	
Mezz3_Fab_C			Port 12	Port 12		
Mezz4_Fab_B		Port 12			Port 12	

<b>Blade 5</b>	<b>I/O Module</b>					
	<b>A1</b>	<b>B1</b>	<b>C1</b>	<b>C2</b>	<b>B2</b>	<b>A2</b>
Integrated LOM1	Port 5					Port 5
Integrated LOM2	Port 13					Port 13
Mezz1_Fab_C			Port 5	Port 5		
Mezz2_Fab_B		Port 5			Port 5	
Mezz3_Fab_C			Port 13	Port 13		
Mezz4_Fab_B		Port 13			Port 13	

<b>Blade 6</b>	<b>I/O Module</b>					
	<b>A1</b>	<b>B1</b>	<b>A1</b>	<b>C2</b>	<b>B2</b>	<b>A2</b>
Integrated LOM1	Port 6					Port 6
Integrated LOM2	Port 14					Port 14
Mezz1_Fab_C			Port 6	Port 6		



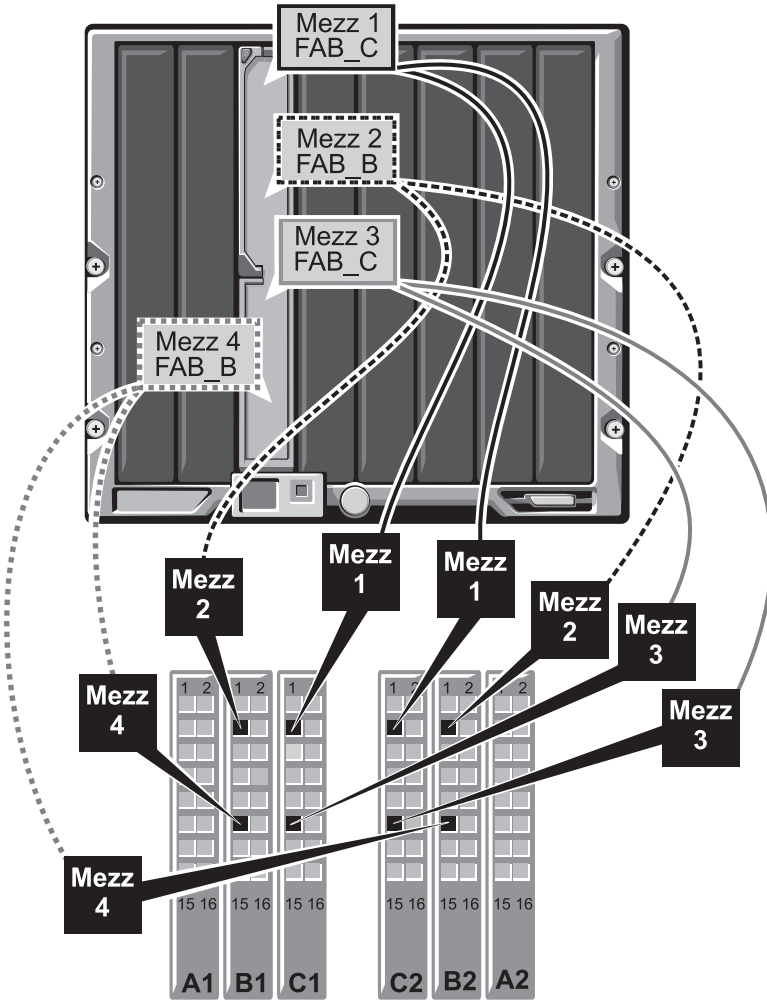
<b>Blade 6</b>	<b>I/O Module</b>					
	<b>A1</b>	<b>B1</b>	<b>A1</b>	<b>C2</b>	<b>B2</b>	<b>A2</b>
Mezz2_Fab_B		Port 6			Port 6	
Mezz3_Fab_C			Port 14	Port 14		
Mezz4_Fab_B		Port 14			Port 14	

<b>Blade 7</b>	<b>I/O Module</b>					
	<b>A1</b>	<b>B1</b>	<b>C1</b>	<b>C2</b>	<b>B2</b>	<b>A2</b>
Integrated LOM1	Port 7					Port 7
Integrated LOM2	Port 15					Port 15
Mezz1_Fab_C			Port 7	Port 7		
Mezz2_Fab_B		Port 7			Port 7	
Mezz3_Fab_C			Port 15	Port 15		
Mezz4_Fab_B		Port 15			Port 15	

<b>Blade 8</b>	<b>I/O Module</b>				<b>V</b>	
	<b>A1</b>	<b>A1</b>	<b>A1</b>	<b>C2</b>	<b>B2</b>	<b>A2</b>
Integrated LOM1	Port 8					Port 8
Integrated LOM2	Port 16					Port 16
Mezz1_Fab_C			Port 8	Port 8		
Mezz2_Fab_B		Port 8			Port 8	
Mezz3_Fab_C			Port 16	Port 16		
Mezz4_Fab_B		Port 16			Port 16	

Figure 1-16 shows the port connections for a full-height blade in bay 3 with four mezzanine cards.

**Figure 1-16. Example of Full-Height Blade Port Mapping – Blade 3**



### Half-Height Blades (PowerEdge M600 and M605)

For a half-height blade in bay  $n$ :

- The integrated NIC will connect to I/O module A1, port  $n$  and I/O module A2, port  $n$ .
- Mezzanine card B will connect to I/O module B1, port  $n$  and I/O module B2, port  $n$ .
- Mezzanine card C will connect to I/O module C1, port  $n$  and I/O module C2, port  $n$ .

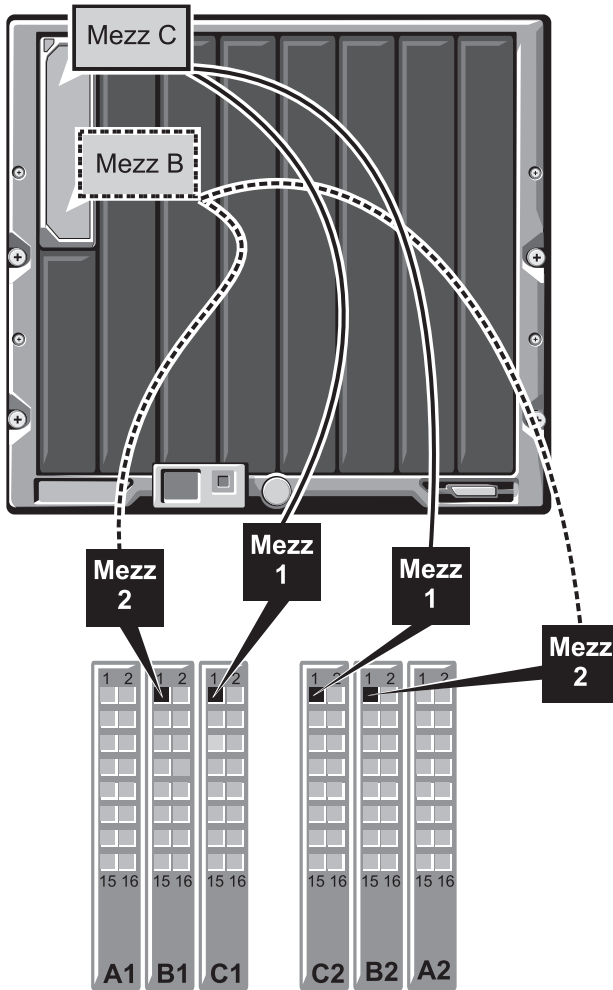
For example, in a blade in slot 12, the integrated NIC will connect to I/O module A1, port 12 and I/O module A2, port 12.

**Table 1-13. Example of I/O Module Port Assignments - Half-Height Blade 1**

Blade 1	I/O Module					
	A1	B1	C1	C2	B2	A2
Integrated LOM	Port 1					Port 11
Mezzanine Card C			Port 1	Port 1		
Mezzanine Card B		Port 1			Port 1	

Figure 1-17 shows the port connections for a half-height blade in bay 1 with two mezzanine cards.

**Figure 1-17. Example of Half-Height Blade Port Mapping**



## Cisco SFS M7000e Infiniband Switch Module

The Cisco SFS M7000e Infiniband switch module includes 24 4x DDR Infiniband ports. Eight ports are external uplink ports, and 16 internal ports provide connectivity to the blades in the enclosure. This switch module is hot-pluggable, and may be installed in Fabric B or Fabric C. For general information on installing this module, see "I/O Modules" on page 166.

**Figure 1-18. Cisco SFS M7000e Infiniband Switch Module Features**



- |   |                             |   |                           |
|---|-----------------------------|---|---------------------------|
| 1 | Infiniband ports (8)        | 2 | port status indicator (8) |
| 3 | diagnostic status indicator | 4 | power indicator           |

**Table 1-14. Cisco SFS M7000e Infiniband Switch Indicators**

<b>Indicator Type</b>	<b>Pattern</b>	<b>Description</b>
Infiniband port status indicator	Off	Link error or Subnet Manager not operating
	Green flickering	I/O activity on port
	Green on	Link established
Module status indicator	Off	Switch is not ready
	Blue on	Switch operating normally
	Amber on or blinking	Fault condition in module
Module power indicator	Off	Power to the module is off
	Green	Module has power

### **PowerConnect M6220 Ethernet Switch Module**

The PowerConnect M6220 Ethernet switch module includes four external 10/100/1000 Mbps Ethernet connectors and one USB type A form factor serial connector. See Figure 1-19.

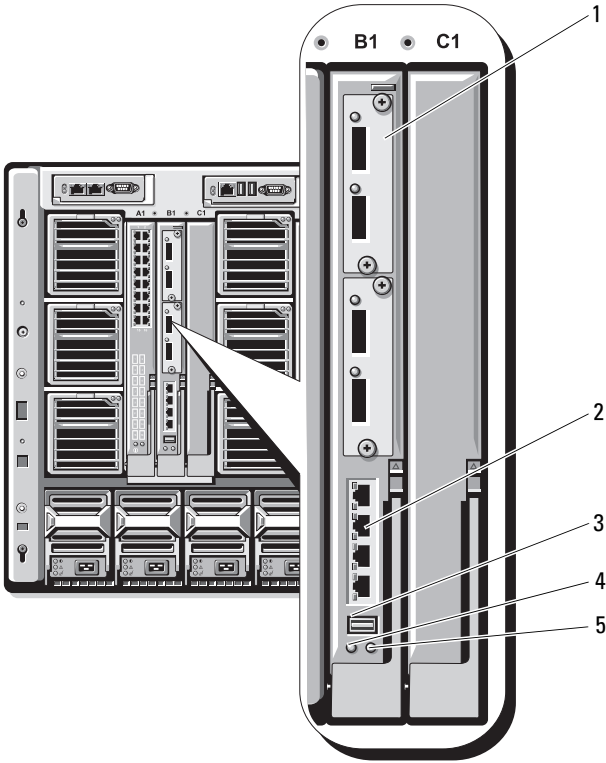
Two option bays support the following three module options:

- A resilient stacking module with 2 x 24 Gb stacking ports
- A 10 Gb Ethernet module with two 10 Gb optical XFP connectors
- A 10 Gb Ethernet module with two copper CX4 uplinks.

Installing two option modules provides additional stacking and redundancy support. Sixteen internal Gb Ethernet connectors link to the blades in the enclosure.

For additional information about the PowerConnect M6220 Ethernet switch module, see the documentation that shipped with the module. For general information on installing this module, see "I/O Modules" on page 166.

**Figure 1-19. PowerConnect M6220 Ethernet Switch Module Features**



- |   |   |   |   |
|---|---|---|---|
| 1 | optional module (2) (dual 10 Gb Ethernet uplink module shown) | 2 | standard 10/100/1000 Mb Ethernet connectors (4) |
| 3 | serial connector (USB type-A form factor)                     | 4 | power indicator                                 |
| 5 | status/identification indicator                               |   |   |

### **Cisco Ethernet Switch**

Your system supports three Cisco Catalyst Blade Switch (CBS) versions:

- The Cisco 3130G-S switch includes four 10/100/1000 Mb Ethernet uplink ports and two Stackwise Plus ports.

- The Cisco CBS 3130X-S switch includes four 10/100/1000 Mb Ethernet uplink ports, two 10 Gb uplink ports, and two Stackwise Plus ports.
- The Cisco CBS 3032 switch includes four 10/100/1000 Mb Ethernet uplink ports.

The two option bays support the following module options:

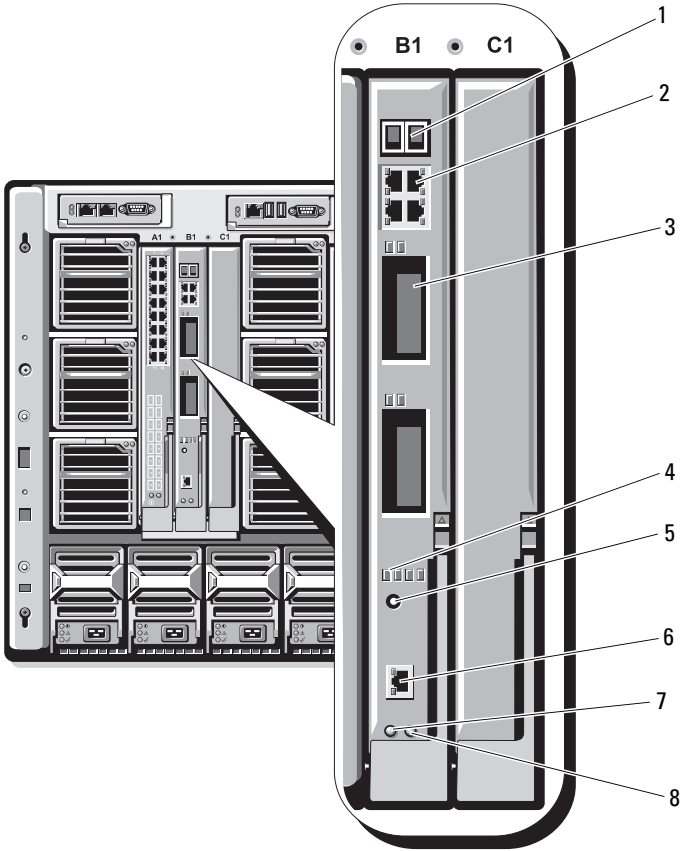
- Cisco X2 10 Gb transceiver modules (CBS 3130X-S only)
- Cisco TwinGig converter modules

All three switches include a RJ-45 console connector for switch management. Sixteen internal Gb Ethernet connectors link to the blades in the enclosure. See Figure 1-19.

For additional information about the Cisco CBS Ethernet switch modules, see the documentation that shipped with the module. For general information on installing this module, see "I/O Modules" on page 166.



**Figure 1-20. Cisco Ethernet Switch Module Features**



- |   |   |   |  |
|---|---|---|--|
| 1 | Stackwise Plus connectors (not enabled in CBS 3032) | 2 | 10/100/1000 Mb Ethernet connectors (4) |
| 3 | option bays (2)                                     | 4 | Cisco status indicators                |
| 5 | mode button   | 6 | console port for switch management     |
| 7 | power indicator                                     | 8 | status/identification indicator        |

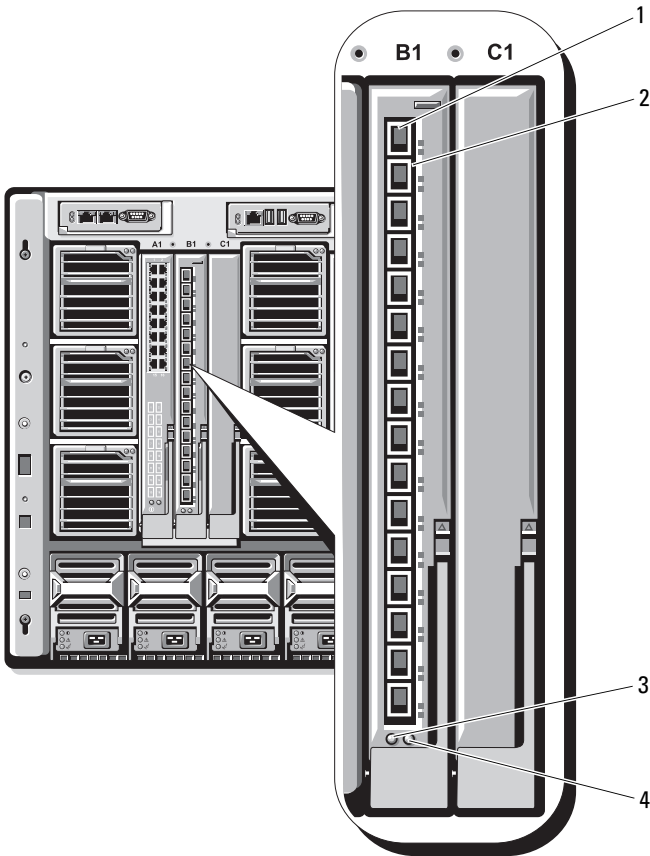
## Fibre Channel Pass-through Module

The Fibre Channel pass-through module provides a bypass connection between a Fibre Channel mezzanine card in the blade and optical transceivers for direct connection into a Fibre Channel switch or a storage array (see Figure 1-21). The 16 pass-through ports on this module can negotiate speeds of 1-, 2-, or 4-Gbps. The Fibre Channel pass-through modules are hot-pluggable, and may be installed in Fabric B or Fabric C. Table 1-15 and list the functionality of the indicators on each individual Fibre Channel connector. For general information on installing this module, see "I/O Modules" on page 166.



**NOTE:** To ensure proper functionality, use only the Short Wave Small Form Factor Pluggable (SFP) transceivers provided with this module.

**Figure 1-21. Fibre Channel Pass-through Module Features**



- |   |                                  |   |   |
|---|----------------------------------|---|---|
| 1 | SFP Fibre Channel connector (16) | 2 | Fibre Channel green/amber indicators (two per port) |
| 3 | power indicator                  | 4 | status/identification indicator                     |

**Table 1-15. Fibre Channel Pass-through Indicators**

<b>Indicator Type</b>	<b>Pattern</b>	<b>Description</b>
Power indicator	Off	Power to the module is off
	Green	Module has power.
Status/identification indicator	Blue on	Primary module in a stack, if applicable
	Blue off	Secondary module in a stack
	Amber flashing	Fault condition in module
Fibre Channel port indicators with Emulex mezzanine card installed		
	Green off, amber off	Mezzanine board failure before POST
	Green off, amber on or green off, amber blinking	Mezzanine board failure during POST
	Green off, amber flashing irregularly	POST in progress
	Green on, amber off or green on, amber on	Mezzanine board failure during operation
	Green on, one fast amber blink	1 Gb link established
	Green on, two fast amber blinks	2 Gb link established
	Green on, three fast amber blinks	4 Gb link established
	Slow green blinking, amber off	No link established
	Slow green blinking, slow amber blinking	Offline for firmware download

**Table 1-15. Fibre Channel Pass-through Indicators (continued)**

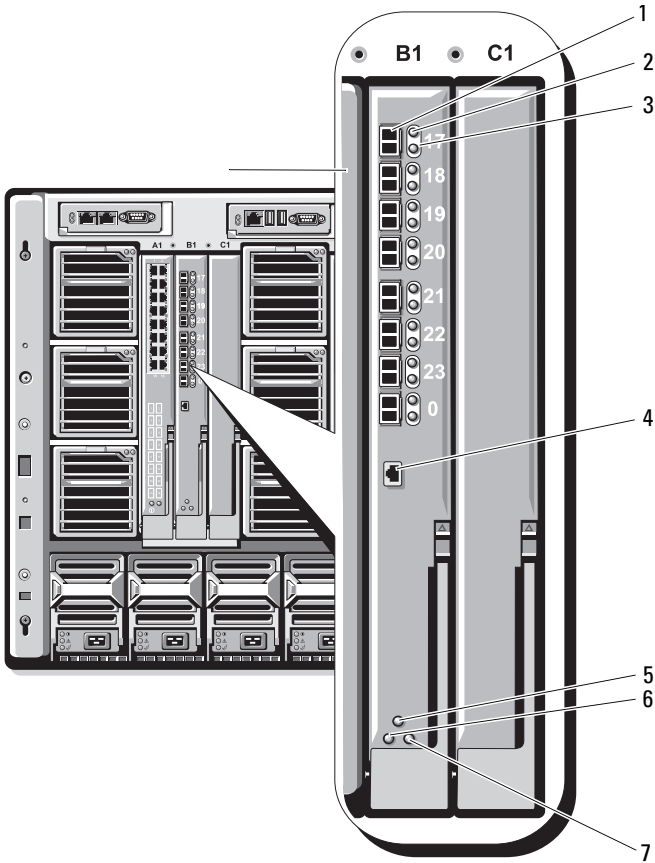
Indicator Type	Pattern	Description
Fibre Channel Port LEDs with Qlogic Mezzanine Card Installed		
	Green off, amber off	Power off
	Green off, amber on	Online, 1 Gb or 2 Gb link
	Green on, amber off	Online, 4Gb link
	Green off, amber flashing	I/O activity, 1 Gb or 2 Gb
	Green flashing, amber off	I/O activity, 4 Gb
	Green flashing and amber flashing at same time	Loss of synchronization
	Green flashing and amber flashing at different intervals	Firmware error
	Off/amber flashing (twice per second)	Connection has lost synchronization.

### **Brocade M4424 SAN I/O Module**

The Brocade M4424 SAN I/O module includes eight external autosensing Fibre Channel ports (four ports are enabled in the standard configuration and four additional ports may be enabled as an optional upgrade), 16 internal ports, and one serial port with an RJ-45 connector. The external Fibre Channel ports operate at 1 Gb/sec, 2 Gb/sec, or 4 Gb/sec. The Fibre Channel switch module is hot-pluggable, and may be installed in Fabric B or Fabric C. For general information on installing this module, see "I/O Modules" on page 166.

**NOTE:** The Fibre Channel switch module includes Short Wave Small Form Factor Pluggable (SFP) optical transceivers. To ensure proper functionality, use only SFPs provided with this module.

**Figure 1-22. Brocade M4424 SAN I/O Module Features**



- |   |  |   |   |
|---|--|---|---|
| 1 | Fibre Channel port (8)                 | 2 | Fibre Channel port status indicator (8) |
| 3 | Fibre Channel port speed indicator (8) | 4 | serial port (RJ-45 connector)           |

- 5    module status indicator
- 6    power indicator
- 7    status/identification indicator

**Table 1-16. Brocade M4424 SAN I/O Module Indicators**

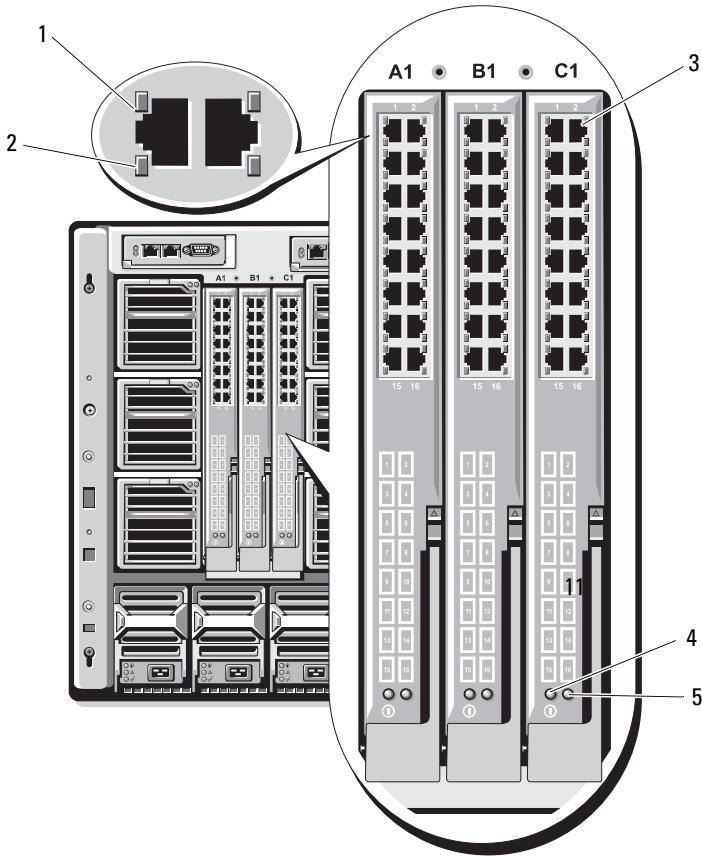
<b>Indicator Type</b>	<b>Pattern</b>	<b>Description</b>
Fibre Channel port status indicator	Off	No signal carrier
	Amber on	Signal present but not online
	Green on	Online, but no activity
	Green blinking slowly	Online but segmented
	Green blinking quickly	Internal loopback
	Green flickering	I/O activity on port
	Amber blinking slowly	Port disabled
	Amber blinking rapidly	Error or fault with port
Fibre Channel port speed indicator	Off	1 Gb link established
	Green on	2 Gb link established
	Amber on	4 Gb link established
Module status indicator	Off	Module is off or enclosure power is off.
	Green on	All ports are ready for use
	Amber on	Module is booting being reset, or ports are offline
	Green/amber blinking	Diagnostic message in error log, or environmental range exceeded
Module power indicator	Off	Power to the module is off
	Green	Module has power.
Status/identification indicator	Blue on	Primary module in a stack, if applicable
	Blue off	Secondary module in a stack
	Amber flashing	Fault condition in module

## **Ethernet Pass-through Module**

The Ethernet pass-through module supports 10/100/1000 Mb connections, and provides a direct connection between the optional internal Ethernet mezzanine card in the blade, and an external Ethernet device (see Figure 1-23). The Ethernet pass-through modules are hot-pluggable, and may be installed in any of the three Fabrics. Table 1-17 lists the functionality of the Ethernet pass-through module indicators. For additional information on installing this module, see "I/O Modules" on page 166.



**Figure 1-23. Ethernet Pass-through Module Features**



- |   |                                 |   |                         |
|---|---------------------------------|---|-------------------------|
| 1 | link indicator (16)             | 2 | activity indicator (16) |
| 3 | RJ45 Ethernet connector (16)    | 4 | power indicator         |
| 5 | status/identification indicator |   |                         |



**NOTE:** Connectors on the Ethernet pass-through module correspond directly to the blade number. For example, blade 5 is connected to port 5 on the Ethernet pass-through module. Integrated network adapter 1 will map to I/O slot A1. Integrated network adapter 2 will map to I/O slot A2.

**Table 1-17. Ethernet Pass-through Module Indicators**

Indicator Type	Pattern	Description
Link indicator/activity indicator	Green on, amber blinking	The Ethernet connector is linked to the blade and there is network activity.
	Green on, amber off	The Ethernet connector is linked to the blade and there is no network activity.
	Green off, amber blinking	The Ethernet connector is not linked to the blade and there is network activity.
	Green off/amber off	The Ethernet connector is not linked to the blade and there is no network activity.
Power indicator	Off	Power to the module is off.
	Green	Module has power.
Status/identification indicator	Blue on	Active module.
	Amber flashing	Fault condition in module.

**NOTE:** Ethernet media speed is configured through the blade LOM firmware or by the operating system. Speed and duplex settings are not configured through the pass-through module itself.

## System Messages

Table 1-18 lists the system messages that can occur and the probable cause and corrective action for each message.



**CAUTION:** Many repairs may only be done by a certified service technician. You should only perform troubleshooting and simple repairs as authorized in your product documentation, or as directed by the online or telephone service and support team. Damage due to servicing that is not authorized by Dell is not covered by your warranty. Read and follow the safety instructions that came with the product.



**NOTE:** If you receive a system message that is not listed in Table 1-18, check the documentation for the application that is running when the message appears, or the operating system's documentation for an explanation of the message and recommended action.

**Table 1-18. Blade Messages**

<b>Message</b>	<b>Causes</b>	<b>Corrective Actions</b>
Alert: DIMM_n and DIMM_n must be populated with a matched set of DIMMs if more than 1 DIMM is present. The following memory DIMMs have been disabled.	The installed memory configuration is invalid.	Ensure that the memory modules are installed in matched pairs. See "System Memory" on page 105.
Alert! Node Interleaving disabled! Memory configuration does not support Node Interleaving.	The installed memory configuration does not support node interleaving.	Install a memory configuration that supports node interleaving. See "System Memory" on page 105.
Alert! Redundant memory disabled! Memory configuration does not support redundant memory.	The installed memory configuration does not support redundant memory.	Install a memory configuration that supports redundant memory. See "System Memory" on page 105.  Disable the <b>Redundant Memory</b> option in the System Setup program. See "Using the System Setup Program" on page 79.
Alert! Redundancy was previously lost. Power cycle required to reconfigure redundant memory.	Memory error.	Power cycle the blade.

**Table 1-18. Blade Messages (continued)**

<b>Message</b>	<b>Causes</b>	<b>Corrective Actions</b>
Alert! Unsupported memory, incomplete sets, or unmatched sets. The following memory DIMMs have been disabled:	The installed memory configuration is invalid.	Add, move, or remove memory modules to achieve a configuration supported by the system. See "System Memory" on page 105.
Caution! NVRAM_CLR jumper is installed on system board.	NVRAM_CLR jumper is set to "on."	Set the NVRAM_CLR jumper to "off." See Figure 7-1, Figure 7-2, Figure 7-3 or Figure 7-4 for the jumper location.
CPUs with different cache sizes detected.	Mismatched processors are installed.	Install a correct version of the microprocessor so that both microprocessors have the same cache size. See "Processors" on page 128.
Decreasing available memory.	Faulty or improperly installed memory modules.	Ensure that all memory modules are properly installed. See "Troubleshooting Blade Memory" on page 191.
DIMMs should be installed in pairs. Pairs must be matched in size, speed, and technology.	Mismatched or unmatched DIMMs installed; faulty or improperly installed memory modules. The system will operate in a degraded mode with reduced ECC protection. Only memory installed in channel 0 will be accessible.	Ensure that all pairs of memory modules are of the same type and size and that they are properly installed. See "System Memory" on page 105. If the problem persists, see "Troubleshooting Blade Memory" on page 191.

**Table 1-18. Blade Messages (continued)**

<b>Message</b>	<b>Causes</b>	<b>Corrective Actions</b>
DIMMs must be populated in sequential order beginning with slot 1. The following DIMM is electrically isolated: DIMM x.	The specified DIMM is inaccessible to the system due to its location. DIMMs must be populated in sequential order, beginning with slot 1.	Populate two, four, or eight DIMMs sequentially.
DIMM pairs must be matched in size, speed, and technology. The following DIMM pair is mismatched: DIMM x and DIMM y.	Mismatched or unmatched DIMMs installed; faulty or improperly seated memory modules.	Ensure that all pairs of memory modules are of the same type and size, and that they are properly installed. See "System Memory" on page 105. See "Troubleshooting Blade Memory" on page 191.
Diskette read failure.	Faulty or improperly inserted diskette.	Replace the diskette.
Drive not ready.	Diskette missing or improperly inserted in diskette drive.	Reinsert or replace the diskette.
Error: Incorrect memory configuration. DIMMs must be installed in pairs of matched memory size, speed, and technology.	Mismatched or unmatched DIMMs installed; faulty or improperly seated memory modules.	Ensure that all pairs of memory modules are of the same type and size, and that they are properly installed. See "System Memory" on page 105. If the problem persists, see "Troubleshooting Blade Memory" on page 191.
Error: Incorrect memory configuration. System halted.	Less than 512 MB of memory installed.	Add memory modules to achieve a configuration supported by the system. See "System Memory" on page 105.

**Table 1-18. Blade Messages (continued)**

<b>Message</b>	<b>Causes</b>	<b>Corrective Actions</b>
Error: Memory failure detected. Memory size reduced. Replace the faulty DIMM as soon as possible.	Faulty or improperly seated memory modules.	See "Troubleshooting Blade Memory" on page 191.
Error programming flexAddress (MAC) for <i>bus, device, function</i> .	FlexAddress (virtual MAC) is not supported on the specified device.	Information only
Error programming flexAddress (iSCSI MAC) for <i>bus, device, function</i> .	FlexAddress (virtual MAC) is not supported on the specified device.	Information only
Error resetting NIC after programming flexAddress for <i>bus, device, function</i> .	FlexAddress (virtual MAC) is not supported on the specified device.	Information only
FBD training error: The following branch has been disabled: Branch x.	The specified branch (channel pair) contains DIMMs that are incompatible with each other.	Ensure that only Dell qualified memory is used. Dell recommends purchasing memory upgrade kits directly from <a href="http://www.dell.com">http://www.dell.com</a> or your Dell sales agent to ensure compatibility.
Gate A20 failure.	Faulty keyboard controller (faulty blade board).	See "Getting Help" on page 217.
General failure.	Operating system corrupted or improperly installed.	Reinstall the operating system.

**Table 1-18. Blade Messages (continued)**

<b>Message</b>	<b>Causes</b>	<b>Corrective Actions</b>
HyperTransport error caused a system reset. Please check the system event log for details.	HyperTransport error.	See "Getting Help" on page 217.
Invalid flexAddress for bus, device, function.	FlexAddress (virtual MAC) is not supported on the specified device.	Information only
Keyboard controller failure.	Faulty keyboard controller (faulty blade board).	See "Getting Help" on page 217.
Keyboard failure.	Loose or improperly connected keyboard cable	Ensure that the keyboard is properly connected. If the problem persists, replace the keyboard.
Manufacturing mode detected.	System is incorrectly configured.	Set the NVRAM_CLR jumper to "on" and reboot the blade. See Figure 7-1, Figure 7-2, Figure 7-3 or Figure 7-4 for the jumper location.

**Table 1-18. Blade Messages (continued)**

<b>Message</b>	<b>Causes</b>	<b>Corrective Actions</b>
Memory address line failure at <i>address</i> , read <i>value</i> expecting <i>value</i> .	Faulty or improperly installed memory modules, or faulty blade board.	Ensure that all memory modules are properly installed. See "Troubleshooting Blade Memory" on page 191. If the problem persists, see "Getting Help" on page 217.
Memory double word logic failure at <i>address</i> , read <i>value</i> expecting <i>value</i> .		
Memory odd/even logic failure at <i>start address</i> to <i>end address</i> .		
Memory write/read failure at <i>address</i> , read <i>value</i> expecting <i>value</i> .		
Memory mirroring enabled.	Memory mirroring enabled	Information only.
Memory tests terminated by keystroke.	The spacebar or ESC key was pressed during POST to terminate the memory test.	Information only.



**Table 1-18. Blade Messages (continued)**

<b>Message</b>	<b>Causes</b>	<b>Corrective Actions</b>
No boot device available.	Faulty or missing diskette drive, optical drive, or hard drive.	Check the <b>Integrated Devices</b> configuration settings in the System Setup program and ensure that the controller for the boot device is enabled. See "Using the System Setup Program" on page 79. Ensure that the controller for the boot device is enabled.  If the problem persists, replace the drive. See "Hard Drives" on page 142.
No boot sector on hard-disk drive.	An operating system is not on the hard drive.	Check the hard-drive configuration settings in the System Setup program. See "Using the System Setup Program" on page 79.
No timer tick interrupt.	Faulty blade board.	See "Getting Help" on page 217.
Not a boot diskette.	Not a bootable diskette.	Use a bootable diskette.
PCI BIOS failed to install.	Faulty or improperly installed mezzanine card.	Reseat the mezzanine card. See "I/O Module Mezzanine Cards" on page 123. If the problem persists, see "Getting Help" on page 217.
Plug & Play Configuration Error.	Error encountered in initializing PCI device; faulty blade board.	Set the NVRAM_CLR jumper to "on" and reboot the blade. See Figure 7-1, Figure 7-2, Figure 7-3 or Figure 7-4 for the jumper location.  Check for a BIOS update. If the problem persists, see "Getting Help" on page 217.

**Table 1-18. Blade Messages (continued)**

<b>Message</b>	<b>Causes</b>	<b>Corrective Actions</b>
Read fault.	Faulty diskette, diskette drive, or optical drive.	Replace the diskette. Ensure that the drive cable is properly connected. See "Troubleshooting USB Devices" on page 183 or "Troubleshooting Hard Drives" on page 192 for the appropriate drive(s) installed in your system.
Remote Configuration update attempt failed.	Blade could not implement Remote Configuration request.	Retry Remote Configuration.
Sector not found. Seek error. Seek operation failed.	Faulty diskette or hard drive.	Replace the diskette. If the problem persists, see "Troubleshooting Hard Drives" on page 192 for the appropriate drive installed in your system.
Shutdown failure.	Shutdown test failure.	Ensure that all memory modules are properly installed. See "Troubleshooting Blade Memory" on page 191. If the problem persists, see "Getting Help" on page 217.
Spare bank enabled.	Memory sparing enabled.	Information only.
The amount of system memory has changed.	Faulty memory module.  Information only, if you have changed the memory configuration.	See "Troubleshooting Blade Memory" on page 191. If the problem persists, see "Getting Help" on page 217.

**Table 1-18. Blade Messages (continued)**

<b>Message</b>	<b>Causes</b>	<b>Corrective Actions</b>
This system does not support processors greater than 95W.	Unsupported processor(s) installed.	Replace the processor(s) with a supported version. See "Processors" on page 128.
This system only supports Opteron 2000 series processors. System halted.	Unsupported processor(s) installed.	Replace the processor(s) with a supported version. See "Processors" on page 128.
Time-of-day clock stopped.	Faulty battery; faulty blade board.	See "Troubleshooting Blade Memory" on page 191. If the problem persists, see "Getting Help" on page 217.
Time-of-day not set – please run SETUP program.	Incorrect <b>Time</b> or <b>Date</b> settings; faulty blade board battery.	Check the <b>Time</b> and <b>Date</b> settings. See "Using the System Setup Program" on page 79. If the problem persists, see "Troubleshooting the NVRAM Backup Battery" on page 195.
Timer chip counter 2 failed.	Faulty blade board.	See "Getting Help" on page 217.
TPM failure	A Trusted Platform Module (TPM) function has failed.	See "Getting Help" on page 217.
Unsupported CPU combination.	Mismatched processors are installed. Processor is not supported by the blade.	Replace a microprocessor so that both microprocessors match. See "Processors" on page 128.  Check for a BIOS update using the Dell Support website at <a href="http://support.dell.com">support.dell.com</a> .

**Table 1-18. Blade Messages (continued)**

<b>Message</b>	<b>Causes</b>	<b>Corrective Actions</b>
Unsupported CPU stepping detected.	Processor is not supported by the blade.	Check for a BIOS update using the Dell Support website at <a href="http://support.dell.com">support.dell.com</a> . If the problem persists, install a supported processor. See "Processors" on page 128.
Warning! A fatal error has caused system reset. Please check the event log for details.	Unspecified error.	Check the system event log for information about the error.
Warning! Following faulty DIMMs are disabled: DIMMxx, DIMMyy.	Faulty or improperly seated memory modules.	See "Troubleshooting Blade Memory" on page 191.
Warning! No microcode update loaded for processor n.	Unsupported processor.	Update the BIOS firmware using the Dell Support website at <a href="http://support.dell.com">support.dell.com</a> .
Warning: The current memory configuration is not validated. Change it to the recommended memory configuration or press any key to continue.	There is no memory configuration error, but the memory configuration is not recommended by Dell.	See "System Memory" on page 105.

**Table 1-18. Blade Messages (continued)**

<b>Message</b>	<b>Causes</b>	<b>Corrective Actions</b>
Warning: The current memory configuration is not optimal. For more information on valid memory configurations, please see the Hardware Owner's Manual on the technical support site.	There is no memory configuration error, but the memory configuration is not recommended by Dell.	See "System Memory" on page 105.
Write fault. Write fault on selected drive.	Faulty diskette, diskette drive, or optical drive.	Replace the diskette. Ensure that the drive cable is properly connected. See "Troubleshooting USB Devices" on page 183 or "Troubleshooting Hard Drives" on page 192 for the appropriate drive(s) installed in your system.

## Warning Messages

A warning message alerts you to a possible problem and prompts you to respond before the system continues a task. For example, before you format a diskette, a message will warn you that you may lose all data on the diskette. Warning messages usually interrupt the task and require you to respond by typing y (yes) or n (no).



**NOTE:** Warning messages are generated by either the application or the operating system. For more information, see the documentation that accompanied the operating system or application.

## **Diagnostics Messages**

When you run system diagnostics, an error message may result. Diagnostic error messages are not covered in this section. Record the message on a copy of the Diagnostics Checklist in "Getting Help" on page 217, then follow the instructions in that section for obtaining technical assistance.

## **Alert Messages**

Systems management software generates alert messages for your system. Alert messages include information, status, warning, and failure messages for drive, temperature, fan, and power conditions. For more information, see the systems management software documentation.

# Using the System Setup Program

After you set up your system, run the System Setup program to familiarize yourself with your system configuration and optional settings. Record the information for future reference.

You can use the System Setup program to:

- Change the system configuration stored in NVRAM after you add, change, or remove hardware
- Set or change user-selectable options—for example, the time or date
- Enable or disable integrated devices
- Correct discrepancies between the installed hardware and configuration settings



**NOTE:** When a blade is inserted into an enclosure, the blade functions as a system. Each blade has a System Setup program to allow configuration of the blade and features such as password protection.

## Entering the System Setup Program

- 1 Turn on or restart the blade.
- 2 Press <F2> immediately after you see the following message:

<F2> = Setup


If your operating system begins to load before you press <F2>, allow the system to finish booting, and then restart your system and try again.



**NOTE:** To ensure an orderly system shutdown, see the documentation that accompanied your operating system.

## Responding to Error Messages

You can enter the System Setup program by responding to certain error messages. If an error message appears while the system is booting, make a note of the message. Before entering the System Setup program, see "System Messages" on page 66 and "Warning Messages" on page 77 for an explanation of the message and suggestions for correcting errors.


 **NOTE:** After installing a memory upgrade, it is normal for your system to send a message the first time you start your system.

## Using the System Setup Program

Table 2-1 lists the keys that you use to view or change information on the System Setup program screens and to exit the program.

**Table 2-1. System Setup Program Navigation Keys**

Keys	Action
Up arrow or <Shift><Tab>	Moves to the previous field.
Down arrow or <Tab>	Moves to the next field.
Spacebar, <+>, <->, left and right arrows	Cycles through the settings in a field. In some fields, you can also type the appropriate value.
<Esc>	Exits the System Setup program and restarts the system if any changes were made.
<F1>	Displays the System Setup program's help file.

 **NOTE:** For most of the options, any changes that you make are recorded but do not take effect until you restart the system.

## System Setup Options

### Main Screen

When you enter the System Setup program, the main System Setup program screen appears (see Figure 2-1).



**Figure 2-1. Main System Setup Program Screen**

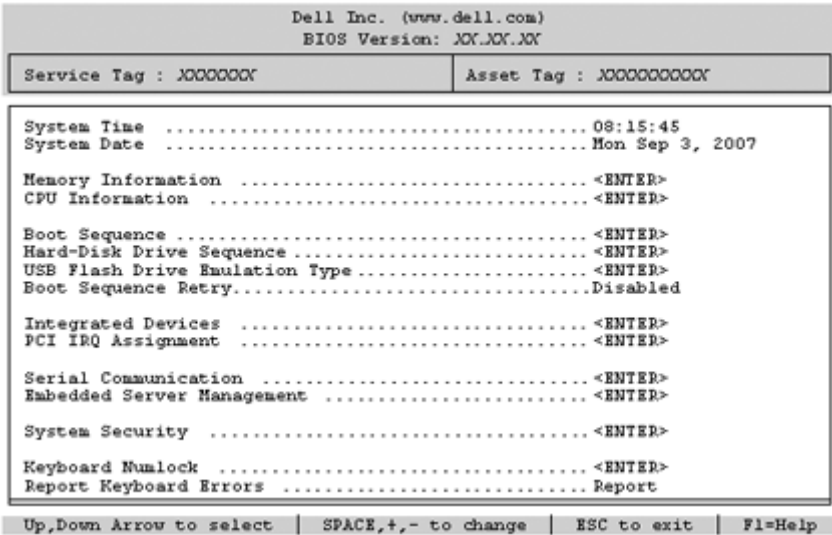




Table 2-2 lists the options and descriptions for the information fields that appear on the main System Setup program screen.

-  **NOTE:** The options for the System Setup program change based on the system configuration.
-  **NOTE:** The System Setup program defaults are listed under their respective options, where applicable.

**Table 2-2. System Setup Program Options**

Option	Description
Asset Tag	Displays the customer-programmable asset tag number for the system if an asset tag number has been assigned. To enter an asset tag number of up to 10 characters into NVRAM, see "Acquiring the asset.com Utility" on page 94.
System Time	Resets the time on the system's internal clock.
System Date	Resets the date on the system's internal calendar.
Memory Information	See "Memory Information Screen" on page 83.
CPU Information	See "CPU Information Screen" on page 84.

**Table 2-2. System Setup Program Options (continued)**

Option	Description
Boot Sequence	Determines the order of devices from which the system attempts to boot during system startup. Available options can include a USB diskette drive, USB DVD/CD drive, hard drives, and USB flash drive. <b>NOTE:</b> The USB diskette and DVD/CD-ROM device will be displayed in the boot order setup screen even if they are not attached to the system before you run the System Setup program
Hard-Disk Drive Sequence	Determines the order in which the BIOS will attempt to boot from hard drives in the system during system startup.
USB Flash Drive Emulation Type (Auto default)	Determines the emulation type for a USB flash drive. <b>Hard disk</b> allows the USB flash drive to act as a hard drive. <b>Floppy</b> allows the USB flash drive to act as a removable diskette drive. <b>Auto</b> automatically chooses an emulation type. <b>Auto</b> automatically chooses the appropriate emulation type for the device, except for devices installed in the SD card slot. A device installed in the SD card slot will automatically emulate a hard drive. If you install a device in this slot that is configured as a removable diskette drive, you must manually set the emulation type to <b>Floppy</b> .
Boot Sequence Retry (Disabled default)	If this field is enabled and the system has failed to boot, the system will reattempt to boot after 30 seconds.
Integrated Devices	See "Integrated Devices Screen" on page 85.
PCI IRQ Assignment	Displays a screen to change the IRQ assigned to each of the integrated devices on the PCI bus, and any installed expansion cards that require an IRQ.
Serial Communication	See "Serial Communication Screen" on page 86.
System Security	Displays a screen to configure the system password and setup password features. See "Using the System Password" on page 90 and "Using the Setup Password" on page 93 for more information.
Keyboard NumLock (On default)	Determines whether your system starts up with the NumLock mode activated on 101- or 102-key keyboards (does not apply to 84-key keyboards).

**Table 2-2. System Setup Program Options (continued)**

<b>Option</b>	<b>Description</b>
Report Keyboard Errors ( <b>Report</b> default)	Enables or disables reporting of keyboard errors during the POST. Select <b>Report</b> for host systems that have keyboards attached. Select <b>Do Not Report</b> to suppress all error messages relating to the keyboard or keyboard controller during POST. This setting does not affect the operation of the keyboard itself if a keyboard is attached to the system.

## Memory Information Screen

Table 2-3 lists the options and descriptions for the information fields that appear on the **Memory Information** screen.

**Table 2-3. Memory Information Screen**

<b>Option</b>	<b>Description</b>
System Memory Size	Displays the amount of main memory. (If memory mirroring or spare memory is enabled, this value will be less than the amount of physical memory installed in the blade.) This field does not have user-selectable settings.
System Memory Type	Displays the type of system memory. This field does not have user-selectable settings.
System Memory Speed	Displays the system memory clock frequency. This field does not have user-selectable settings.
Video Memory	Displays the amount of video memory. This field does not have user-selectable settings.
System Memory Testing ( <b>Enabled</b> default)	Determines if memory is being tested during POST. Setting this value to <b>Enabled</b> will affect the duration of system POST.
Node Interleaving ( <b>Disabled</b> default)	If set to <b>Disabled</b> (default), NUMA is employed. If <b>Enabled</b> , memory interleaving is implemented.
Memory Optimizer (PowerEdge M905, M805, M605. <b>Enabled</b> default)	If set to <b>Disabled</b> , the two DRAM controllers operate in 128-bit mode, and memory reliability is enhanced. If set to <b>Enabled</b> , the memory controllers operate independently in 64-bit mode, and memory performance is optimized.

**Table 2-3. Memory Information Screen (continued)**

<b>Option</b>	<b>Description</b>
Redundant Memory (PowerEdge M600)	If a valid memory configuration is installed, you can enable memory mirroring or spare memory. Options are <b>Mirror Mode</b> , <b>Spare Mode</b> , and <b>Disabled</b> . See "System Memory" on page 105.
Redundant Memory (PowerEdge M905, M805, M605)	If a valid memory configuration is installed, you can enable spare memory. Options are <b>Spare Mode</b> , and <b>Disabled</b> . See "System Memory" on page 105.
Low Power Mode (Disabled default)	If set to <b>Disabled</b> , memory runs at full speed. If set to <b>Enabled</b> , memory runs at reduced speed to conserve power.

### **CPU Information Screen**

Table 2-4 lists the options and descriptions for the information fields that appear on the **CPU Information** screen.

**Table 2-4. CPU Information Screen**

<b>Option</b>	<b>Description</b>
64-bit	Displays the processor register width.
Core Speed	Displays the core speed of the processors.
Bus Speed	Displays the bus speed of the processors.
Virtualization Technology (Disabled default)	<b>NOTE: Disable this feature if your system will not be running virtualization software.</b> Displays when the processors support Virtualization Technology. <b>Enabled</b> permits virtualization software to use Virtualization Technology incorporated in the processor design. This feature can only be used by software that supports Virtualization Technology.
Adjacent Cache Line Prefetch (PowerEdge M600. Enabled default)	Enables or disables optimal use of sequential memory access. <b>Enabled</b> optimizes the system for applications that require sequential memory access. <b>Disabled</b> is used for applications with random memory access.
Hardware Prefetcher (Enabled default)	Enables or disables the hardware prefetcher.

**Table 2-4. CPU Information Screen (continued)**

<b>Option</b>	<b>Description</b>
Demand-Based Power Management ( <b>Enabled</b> default)	Enables or disables demand-based power management. When enabled, the CPU Performance State tables will be reported to the operating system; when disabled, the CPU Performance State tables will not be reported to the operating system. If any of the CPUs do not support demand-based power management, the field will become read-only and is automatically set to <b>Disabled</b> .
Processor X ID	Displays the family and model number of each processor. A submenu displays the core speed, the amount of cache memory, and the number of cores of the processor(s)

## Integrated Devices Screen

Table 2-5 lists the options and descriptions for the information fields that appear on the **Integrated Devices** screen.

**Table 2-5. Integrated Devices Screen Options**

<b>Option</b>	<b>Description</b>
Integrated SAS Controller <i>or</i> Integrated RAID controller ( <b>Enabled</b> default.)	Enables the integrated SAS or RAID controller.
User Accessible USB Ports ( <b>All Ports On</b> default)	Enables or disables the system's USB ports. Options are <b>All Ports On</b> or <b>All Ports Off</b> .
SD Card Port (PowerEdge M905 and M805)	Enables or disables the system's internal SD card port. <b>NOTE:</b> This port is dedicated to a hypervisor, if installed.
Embedded Gb NICx ( <b>Enabled with PXE</b> default)	Enables or disables the system's integrated NICs. Options are <b>Enabled</b> , <b>Enabled with PXE</b> , <b>Enabled with iSCSI Boot</b> , and <b>Disabled</b> . PXE support allows the system to boot from the network. Changes take effect after the system reboots.

**Table 2-5. Integrated Devices Screen Options (continued)**

<b>Option</b>	<b>Description</b>
MAC Address	Displays the MAC address for a particular integrated NIC. This field does not have user-selectable settings.
Capability Detected	Displays the features provided by the hardware key installed in the TOE_KEY socket on the system board. <b>NOTE:</b> Some features may require the installation of an additional driver.
OS Watchdog Timer (Disabled default).	If set to <b>Enabled</b> , the operating system will restart the system if it locks up, based on the expiration of a timer. If set to <b>Disabled</b> , in the event of a system lockup, no timer will be set and the OS will not restart the system in the event of a lockup.
I/OAT DMA Engine (PowerEdge M600 only. Disabled default).	If set to <b>Enabled</b> , the I/O Acceleration Technology feature is enabled for network controllers that support this technology.

## Serial Communication Screen

The blade has a single serial port (COM1) which can be enabled for console redirection through the IMC. Table 2-6 lists the options and descriptions for the information fields that appear on the **Serial Communication** screen.

**Table 2-6. Serial Communication Screen Options**

<b>Option</b>	<b>Description</b>
Serial Communication (Off default)	Options are <b>On with Console Redirection</b> via COM1, and <b>Off</b> .
Failsafe Baud Rate (115200 default)	Displays the failsafe baud rate used for console redirection when the baud rate cannot be negotiated automatically with the remote terminal.
Remote Terminal Type (VT 100/VT 220 default)	Select either <b>VT 100/VT 220</b> or <b>ANSI</b> .
Redirection After Boot (Enabled default)	Enables or disables BIOS console redirection after your system boots to the operating system.

## Embedded Server Management Screen

Table 2-7 lists the options and descriptions for the information fields that appear on the **Embedded Server Management** screen.

**Table 2-7. Embedded Server Management Screen Options**

Option	Description
Front Panel LCD Options (Default default)	Options are <b>User Defined LCD String, Default (the system model name and number), or None</b>
Use-Defined LCD String	You can enter a name or other identifier for the system, to be displayed on the LCD module screen.

## System Security Screen

Table 2-8 lists the options and descriptions for the information fields that appear on the **System Security** screen.

**Table 2-8. System Security Screen Options**


Option	Description
System Password	Displays the current status of your system's password security feature and allows you to assign and verify a new password. <b>NOTE:</b> See "Using the System Password" on page 90 for instructions on assigning a password and using or changing an existing blade password.
Setup Password	Restricts access to the System Setup program in the same way that you restrict access to your system using the <b>System Password</b> feature. <b>NOTE:</b> See "Using the System Password" on page 90 for instructions on assigning a setup password and using or changing an existing setup password.

**Table 2-8. System Security Screen Options (continued)**

Option	Description
Password Status	<p>Setting the <b>Setup Password</b> option to <b>Enabled</b> prevents the system password from being changed or disabled at start-up.</p> <p>To <i>lock</i> the system password, assign a setup password in the <b>Setup Password</b> option and then change the <b>Password Status</b> option to <b>Locked</b>. In this state, you cannot change the system password using the <b>System Password</b> option and the system password cannot be disabled at start-up by pressing &lt;Ctrl&gt;&lt;Enter&gt;.</p> <p>To <i>unlock</i> the system password, enter the setup password in the <b>Setup Password</b> field and then change the <b>Password Status</b> option to <b>Unlocked</b>. In this state, you can disable the system password at start-up by pressing &lt;Ctrl&gt;&lt;Enter&gt; and then change the password using the <b>System Password</b> option.</p>
TPM Security (PowerEdge M905 M805, and M605. Off is default)	<p>Sets the reporting of the Trusted Platform Module (TPM) in the system.</p> <p>When set to <b>Off</b>, presence of the TPM is not reported to the operating system.</p> <p>When set to <b>On with Pre-boot Measurements</b>, the system reports the TPM to the operating system and stores the pre-boot measurements (compliant with Trusted Computing Group standards) to the TPM during POST.</p> <p>When set to <b>On without Pre-boot Measurements</b>, the system reports the TPM to the operating system and bypasses pre-boot measurements.</p>
TPM Activation (PowerEdge M905 M805, and M605. No Change is default)	<p>Changes the operational state of the TPM.</p> <p>When set to <b>Activate</b>, the TPM is enabled and activated at default settings.</p> <p>When set to <b>Deactivate</b>, the TPM is disabled and deactivated.</p> <p>The <b>No Change</b> state initiates no action. The operational state of the TPM remains unchanged (all user settings for the TPM are preserved).</p> <p><b>NOTE:</b> This field is read-only when <b>TPM Security</b> is set to <b>Off</b>.</p>



**Table 2-8. System Security Screen Options (continued)**

Option	Description
TPM Clear (M905 M805, and M605 No is default)	 <b>NOTICE:</b> Clearing the TPM will cause loss of all encryption keys in the TPM. This option will prevent booting to the operating system and will result in loss of data if the encryption keys cannot be restored. Be sure to back up the TPM keys prior to enabling this option.  When set to <b>Yes</b> , all the contents of the TPM are cleared. <b>NOTE:</b> This field is read-only when <b>TPM Security</b> is set to <b>Off</b> .
Power Button	Enables or disables the blade's power button. <ul style="list-style-type: none"><li>• If you turn off the blade using the power button and you are using an ACPI-compliant operating system, the blade can perform an orderly shutdown before power is turned off.</li><li>• If the blade is not running an ACPI-compliant operating system, power is turned off immediately after the power button is pressed.</li></ul> The button is enabled in the System Setup program. When disabled, the button can only turn on blade power.
AC Power Recovery ( <b>Last</b> is default)	Determines how the blade reacts when power is restored. If the option is set to <b>Last</b> , the blade returns to the last power state. <b>On</b> turns on the blade after power is restored. When set to <b>Off</b> , the blade remains off after power is restored.

## Exit Screen

After you press <Esc> to exit the System Setup program, the **Exit** screen displays the following options:

- Save Changes and Exit
- Discard Changes and Exit
- Return to Setup

## System and Setup Password Features

- ➔ **NOTICE:** The password features provide a basic level of security for the data on your system. If your data requires more security, use additional forms of protection, such as data encryption programs.
- ➔ **NOTICE:** Anyone can access the data stored on your system if you leave the system running and unattended without having a system password assigned or if you leave your system unlocked so that someone can disable the password by changing a jumper setting.

Your system is shipped to you without the system password feature enabled. If system security is a concern, operate your system only with system password protection.

To change or delete an existing password, you must know the password (see "Deleting or Changing an Existing System Password" on page 92). If you forget your password, you cannot operate your system or change settings in the System Setup program until a trained service technician changes the password jumper setting to disable the passwords, and erases the existing passwords. See "Disabling a Forgotten Password" on page 214.

### Using the System Password

After a system password is assigned, only those who know the password have full use of the system. When the **System Password** option is set to **Enabled**, the system prompts you for the system password after the system starts.

### Assigning a System Password

Before you assign a system password, enter the System Setup program and check the **System Password** option.

When a system password is assigned, the setting shown for the **System Password** option is **Enabled**. If the setting shown for the **Password Status** is **Unlocked**, you can change the system password. If the **Password Status** option is **Locked**, you cannot change the system password. When the system password feature is disabled by a jumper setting, the system password is **Disabled**, and you cannot change or enter a new system password.


When a system password is not assigned and the password jumper on the system board is in the enabled (default) position, the setting shown for the **System Password** option is **Not Enabled** and the **Password Status** field is **Unlocked**. To assign a system password:

- 1 Verify that the **Password Status** option is set to **Unlocked**.
- 2 Highlight the **System Password** option and press <Enter>.
- 3 Type your new system password.

You can use up to 32 characters in your password.

As you press each character key (or the spacebar for a blank space), a placeholder appears in the field.


The password assignment is not case-sensitive. However, certain key combinations are not valid. To erase a character when entering your password, press <Backspace> or the left-arrow key.

 **NOTE:** To escape from the field without assigning a system password, press <Enter> to move to another field, or press <Esc> at any time prior to completing step 5.


- 4 Press <Enter>.
- 5 To confirm your password, type it a second time and press <Enter>.

The setting shown for the **System Password** changes to **Enabled**. Exit the System Setup program and begin using your system.

- 6 Either reboot your system now for your password protection to take effect or continue working.

 **NOTE:** Password protection does not take effect until you reboot the system.

### Using Your System Password to Secure Your System

 **NOTE:** If you have assigned a setup password (see "Using the Setup Password" on page 93), the system accepts your setup password as an alternate system password.

When the **Password Status** option is set to **Unlocked**, you have the option to leave the password security enabled or to disable the password security.

To leave the password security enabled:

- 1 Turn on or reboot your system by pressing <Ctrl><Alt><Del>.
- 2 Press <Enter>.
- 3 Type your password and press <Enter>.

To disable the password security:

- 1 Turn on or reboot your system by pressing <Ctrl><Alt><Del>.
- 2 Press <Ctrl><Enter>.

When the **Password Status** option is set to **Locked** whenever you turn on your system or reboot your system by pressing <Ctrl><Alt><Del>, type your password and press <Enter> at the prompt.

After you type the correct system password and press <Enter>, your system operates as usual.

If an incorrect system password is entered, the system displays a message and prompts you to re-enter your password. You have three attempts to enter the correct password. After the third unsuccessful attempt, the system displays an error message showing the number of unsuccessful attempts and that the system has halted and will shut down. This message can alert you to an unauthorized person attempting to use your system.

Even after you shut down and restart the system, the error message continues to be displayed until the correct password is entered.



**NOTE:** You can use the **Password Status** option in conjunction with the **System Password** and **Setup Password** options to further protect your system from unauthorized changes.

### Deleting or Changing an Existing System Password

- 1 When prompted, press <Ctrl><Enter> to disable the existing system password.  
If you are asked to enter your setup password, contact your network administrator.
- 2 Enter the System Setup program by pressing <F2> during POST.
- 3 Select the **System Security** screen field to verify that the **Password Status** option is set to **Unlocked**.
- 4 When prompted, type the system password.

- 5 Confirm that **Not Enabled** is displayed for the **System Password** option.

If **Not Enabled** is displayed for the **System Password** option, the system password has been deleted. If **Enabled** is displayed for the **System Password** option, press the <Alt><b> key combination to restart the system, and then repeat steps 2 through 5.

## Using the Setup Password

### Assigning a Setup Password

You can assign (or change) a setup password only when the **Setup Password** option is set to **Not Enabled**. To assign a setup password, highlight the **Setup Password** option and press the <+> or <-> key. The system prompts you to enter and verify the password.



**NOTE:** The setup password can be the same as the system password. If the two passwords are different, the setup password can be used as an alternate system password. However, the system password cannot be used in place of the setup password.

You can use up to 32 characters in your password.

As you press each character key (or the spacebar for a blank space), a placeholder appears in the field.

The password assignment is not case-sensitive. However, certain key combinations are not valid. To erase a character when entering your password, press <Backspace> or the left-arrow key.

After you verify the password, the **Setup Password** setting changes to **Enabled**. The next time you enter the System Setup program, the system prompts you for the setup password.

A change to the **Setup Password** option becomes effective immediately (restarting the system is not required).

### Operating With a Setup Password Enabled

If **Setup Password** is set to **Enabled**, you must enter the correct setup password before you can modify most of the System Setup options. When you start the System Setup program, the program prompts you to enter a password.

If you do not enter the correct password in three attempts, the system lets you view, but not modify, the System Setup screens—with the following exception: If **System Password** is not set to **Enabled** and is not locked through the **Password Status** option, you can assign a system password (however, you cannot disable or change an existing system password).



**NOTE:** You can use the **Password Status** option in conjunction with the **Setup Password** option to protect the system password from unauthorized changes.

### **Deleting or Changing an Existing Setup Password**

- 1** Enter the System Setup program and select the **System Security** option.
- 2** Highlight the **Setup Password** option, press <Enter> to access the setup password window, and press <Enter> twice to clear the existing setup password.  
The setting changes to **Not Enabled**.
- 3** If you want to assign a new setup password, perform the steps in "Assigning a Setup Password" on page 93.

## **Disabling a Forgotten Password**

See "Disabling a Forgotten Password" on page 214.

## **Acquiring the asset.com Utility**

The **asset.com** utility is not located in the Service Mode section of the *Dell OpenManage Server Assistant* CD. To acquire this utility, use the *Server Assistant* CD to create a bootable diskette; the utility is then automatically created on that diskette. The **asset.com** utility will be available in the Service Mode section in future releases of the *Server Assistant* CD.

# Installing Blade Components

The procedures in this section describe how to remove and install components in a blade, including:

- Memory modules
- I/O module mezzanine cards
- NIC TOE and iSCSI activation key
- Processors
- Hypertransport (HT) bridge card (service only)
- Blade system board NVRAM backup battery (CMOS battery)
- Hard drives
- Video controller daughter card or riser card
- Hard-drive backplane
- System board (service only)
- Storage controller card (service only)


# Removing and Installing a Blade


## Removing a Blade

- 1 Power down the blade using OS commands or the CMC, and ensure that the blade's power is off.

When a blade is powered off, its front-panel power indicator is off. See Figure 1-6.

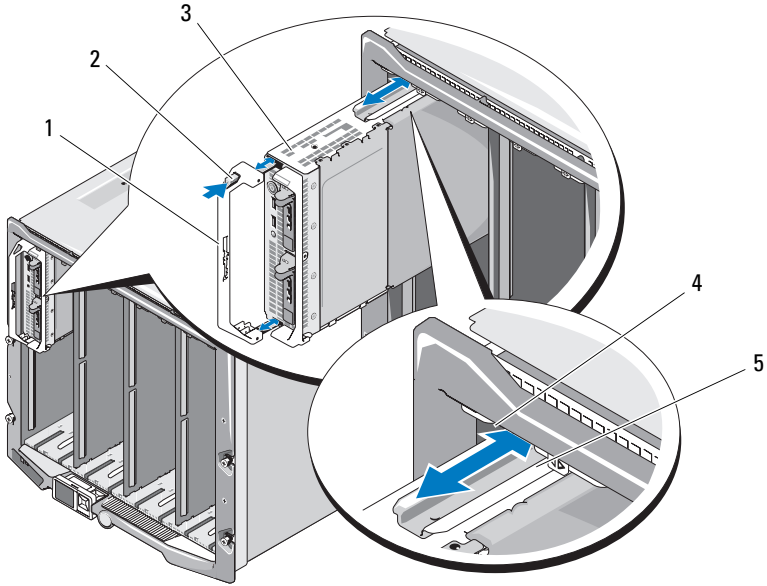
- 2 Before removing full-height blades 1 or 2 or half-height blades 12 or 13, rotate the LCD panel to the storage position to prevent accidental damage to the LCD screen.
- 3 Press in the release button on the handle. See Figure 3-1 or Figure 3-2.
- 4 Pull out the handle to unlock the blade from the enclosure.
- 5 Slide the blade out of the enclosure.
- 6 Install the I/O connector cover over the I/O connector.

 **NOTICE:** To protect the I/O connector pins, install the I/O connector cover any time a blade is removed from the enclosure. (A full-height blade requires two connector covers.)

 **NOTICE:** If you are permanently removing the blade, install a blade blank. (A full-height blade requires two blade blanks.) Operating the system for extended periods of time without a blade blank installed can cause the system to overheat. See "Removing and Installing a Blade Blank" on page 99.

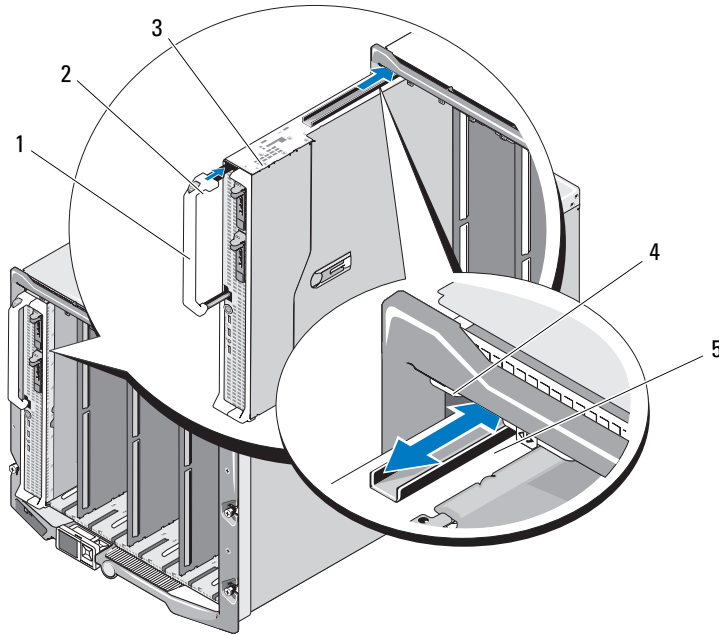


**Figure 3-1. Removing and Installing a Half-Height Blade**



- |   |                                      |   |                                |
|---|--------------------------------------|---|--------------------------------|
| 1 | blade handle                         | 2 | release button                 |
| 3 | blade                                | 4 | guide rail on M1000e enclosure |
| 5 | guide rail on blade (or blade blank) |   |                                |

**Figure 3-2. Removing and Installing a Full-Height Blade**



- |   |                     |   |                                |
|---|---------------------|---|--------------------------------|
| 1 | blade handle        | 2 | release button                 |
| 3 | blade               | 4 | guide rail on M1000e enclosure |
| 5 | guide rail on blade |   |                                |

### **Installing a Blade**

- 1 If you are installing a new blade, remove the plastic cover from the I/O connector(s) and save for future use. See Figure 3-3.
- 2 Orient the blade so that the handle is on the left side of the blade.


- 3 If you are installing a blade in one of the eight upper bays, align the guide rail on the upper edge of the blade so that the rail fits between the plastic guides on the enclosure.

If you are installing a half-height blade in one of the eight lower bays, align the edge of the blade with the guide rail on the floor of the M1000e enclosure.

If you are installing a full-height blade in bays 1 or 2 or a half-height blade in bays 12 or 13, rotate the LCD module to the horizontal storage position to prevent accidental damage to the LCD screen.

- 4 Slide the blade into the enclosure until the handle engages and locks the blade in place.

## Removing and Installing a Blade Blank

 **NOTICE:** If you are permanently removing a blade, install a blade blank. Operating the system for extended periods of time without a full complement of blades or blade blanks can cause the system to overheat.

### Removing a Blade Blank

*If you are removing a blade blank from one of the eight upper bays, press the blue latch at the upper edge of the blank faceplate and slide the blank out of the enclosure.*

*If you are removing a blade blank from one of the eight lower bays, press the blue latch at the lower edge of the blank faceplate, and slide the blank out of the enclosure.*

### Installing a Blade Blank

- 1 Hold the blank with the guide rail facing upwards (see detail in Figure 3-1).
- 2 Install the blank in the enclosure:
  - *If you are installing a blade blank in one of the eight upper bays, align the metal guide rail on the upper edge of the blade blank so that the guide rail fits between the plastic guides on the enclosure (see detail in Figure 3-1).*

- *If you are installing a blade blank in one of the eight lower bays, align the edge of the blank with the plastic guide rail on the floor of the M1000e enclosure, and slide the blank into the enclosure until the lower latch engages.*

## Opening and Closing the Blade

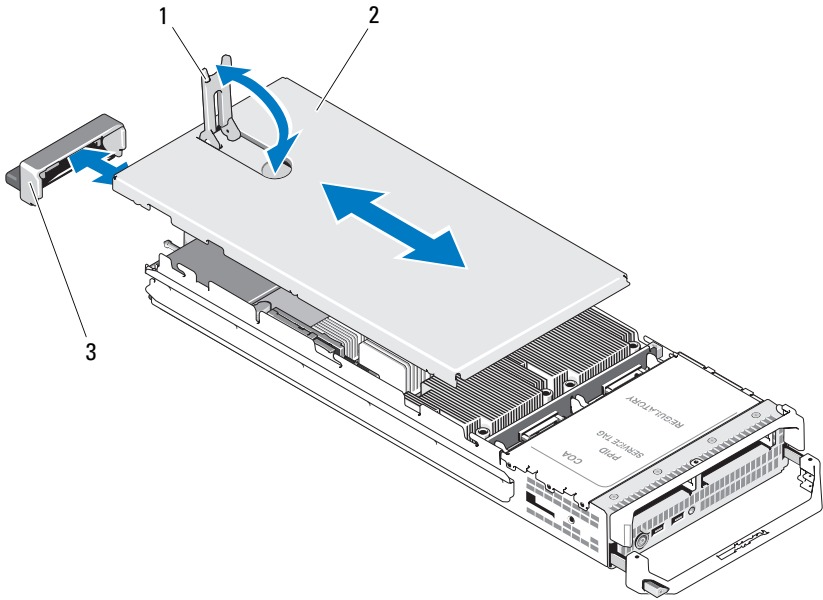
### Opening the Blade



**CAUTION: Only trained service technicians are authorized to remove the system cover and access any of the components inside the system. Before you begin this procedure, review the safety instructions that came with the system.**

- 1 Remove the blade from the enclosure. See "Removing a Blade" on page 96.
- 2 Install the I/O connector cover (s). See Figure 3-3.  
A full-height blade requires two connector covers.
- 3 Orient the blade as shown in Figure 3-3 so that the cover-release latch faces up.
- 4 Lift the cover-release latch and slide the cover toward the back of the blade until it stops.
- 5 Carefully lift the cover away from the blade.

**Figure 3-3. Opening a Blade (PowerEdge M600 Shown)**

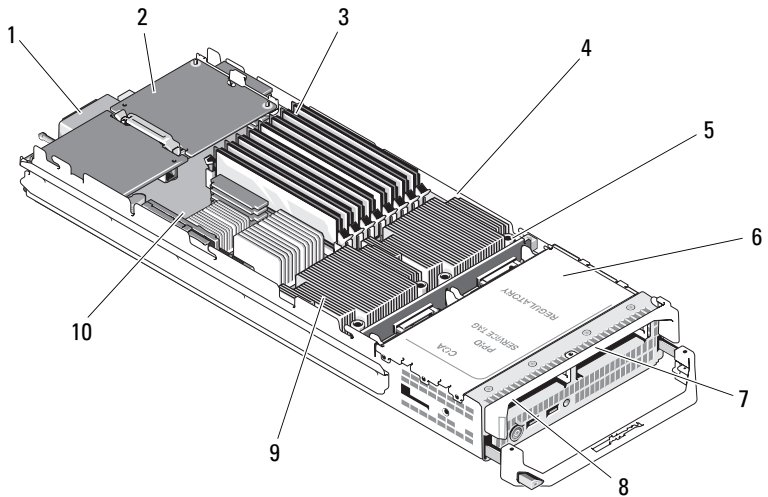


- 1 cover-release latch
- 3 I/O connector cover

- 2 chassis cover

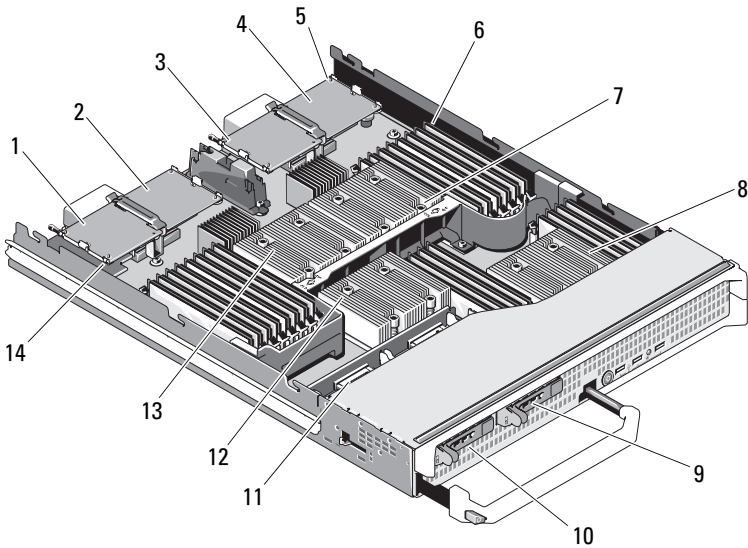
Figure 3-4, Figure 3-5 and Figure 3-6 show the interior components in the blades.

**Figure 3-4. Inside a Half-Height Blade (PowerEdge M600 Shown)**



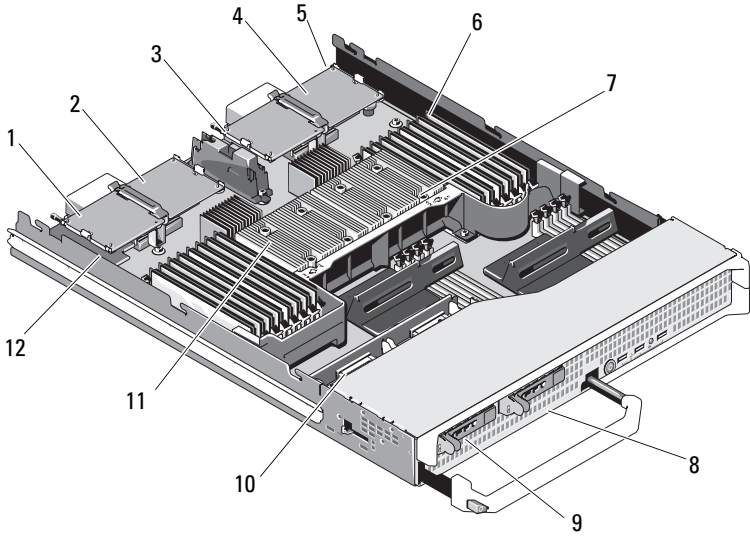
- |   |                                  |    |  |
|---|----------------------------------|----|--|
| 1 | optional Fabric C mezzanine card | 2  | optional Fabric B mezzanine card           |
| 3 | memory modules                   | 4  | processor CPU1 and heat sink               |
| 5 | hard-drive backplane             | 6  | storage controller card (under drive bays) |
| 7 | hard drive 1                     | 8  | hard drive 0                               |
| 9 | processor CPU2 and heat sink     | 10 | video riser card                           |

**Figure 3-5. Inside a Full-Height Blade (PowerEdge M905 Shown)**



- |    |                                      |    |                                      |
|----|--------------------------------------|----|--------------------------------------|
| 1  | optional mezzanine card 1 - Fabric C | 2  | optional mezzanine card 2 - Fabric B |
| 3  | optional mezzanine card 3 - Fabric C | 4  | optional mezzanine card 4 - Fabric B |
| 5  | SD card location                     | 6  | memory modules                       |
| 7  | processor CPU2 and heat sink         | 8  | processor CPU4 and heat sink         |
| 9  | hard drive 1                         | 10 | hard drive 0                         |
| 11 | hard-drive backplane                 | 12 | processor CPU3 and heat sink         |
| 13 | processor CPU1 and heat sink         | 14 | video riser card                     |

**Figure 3-6. Inside a Full-Height Blade (PowerEdge M805 Shown)**



- |    |                                      |    |                                      |
|----|--------------------------------------|----|--------------------------------------|
| 1  | optional mezzanine card 1 - Fabric C | 2  | optional mezzanine card 2 - Fabric B |
| 3  | optional mezzanine card 3 - Fabric C | 4  | optional mezzanine card 4 - Fabric B |
| 5  | SD card location                     | 6  | processor CPU2 and heat sink         |
| 7  | processor CPU2 and heat sink         | 8  | hard drive 1                         |
| 9  | hard drive 0                         | 10 | hard-drive backplane                 |
| 11 | processor CPU1 and heat sink         | 12 | video riser card                     |

**Closing the Blade**

**⚠ CAUTION: Only trained service technicians are authorized to remove the system cover and access any of the components inside the system. Before you begin this procedure, review the safety instructions that came with the system.**

- 1 Ensure that no tools or parts are left inside the blade.
- 2 Align the notches in the edges of the enclosure with the cover alignment pins on the inner sides of the cover.




- 3 Check that these cover-release latch is fully open, and lower the cover onto the enclosure.
- 4 Close the cover-release latch until it is flush with the surface of the cover.

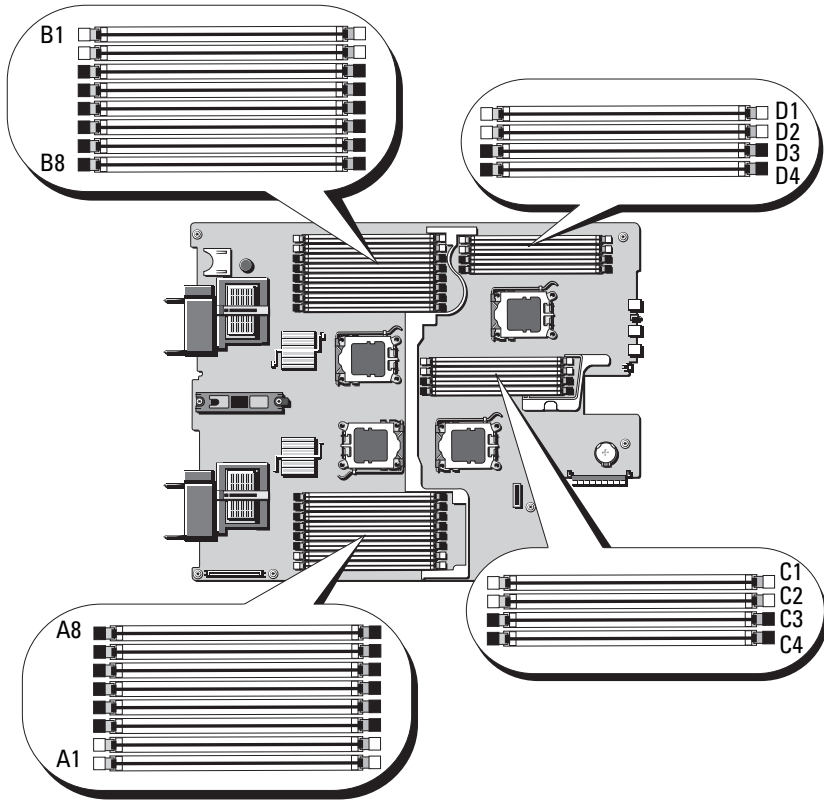
## System Memory

### System Memory - PowerEdge M905

You can upgrade your system memory to a maximum of 192 GB by installing up to twenty-four 667-MHz registered DDR2 memory modules in sets of 1-GB, 2-GB, 4-GB, or 8-GB memory modules. (Dual-rank 8-GB modules are supported; quad-rank 8-GB modules are not supported.) Each processor has four memory channels, organized in sets of two channels.

-  **NOTICE:** If more than four memory modules are installed per processor, the memory modules will be downclocked to operate at 533 Mhz.

**Figure 3-7. Memory Locations - PowerEdge M905**




**General Memory Module Installation Guidelines - PowerEdge M905**

To ensure optimal performance of your system, observe the following guidelines when configuring your system memory.

- Memory modules must be installed in pairs, beginning with the first two sockets in each set of memory modules. These sockets are marked by white retention levers.
- All memory modules in the blade must be identical in speed and technology. The memory modules in each pair must be the same size.

- If pairs of memory modules of different sizes are installed, the larger capacity memory modules must be installed in the lower numbered slots.
- Memory sparing is supported if eight or 16 memory modules are installed. (Memory mirroring is not supported.)

Table 3-1 shows examples of supported memory configurations.

 **NOTICE:** Memory module blanks must be installed in unoccupied memory sockets to maintain proper cooling airflow.

**Table 3-1. Examples of PowerEdge M905 Memory Configurations**

<b>Total System Memory</b>	<b>Memory Modules - Number and Size</b>	<b>Memory Module Locations</b>
8 GB	Eight 1 GB	A1, A2, B1, B2, C1, C2, D1, D2
16 GB	Sixteen 1 GB	A1, A2, A3, A4, B1, B2, B3, B4, C1, C2, C3, C4, D1, D2, D3, D4
16 GB	Eight 2 GB	A1, A2, B1, B2, C1, C2, D1, D2
32 GB	Eight 4 GB	A1, A2, B1, B2, C1, C2, D1, D2
32 GB	Sixteen 2 GB	A1, A2, A3, A4, B1, B2, B3, B4, C1, C2, C3, C4, D1, D2, D3, D4
48 GB	Twenty-four 2 GB	A1, A2, A3, A4, A5, A6, A7, A8, B1, B2, B3, B4, B5, B6, B7, B8, C1, C2, C3, C4, D1, D2, D3, D4
64 GB*	Eight 8 GB	A1, A2, B1, B2, C1, C2, D1, D2
64 GB*	Sixteen 4 GB	A1, A2, A3, A4, B1, B2, B3, B4, C1, C2, C3, C4, D1, D2, D3, D4
96 GB	Twenty-four 4 GB	A1, A2, A3, A4, A5, A6, A7, A8, B1, B2, B3, B4, B5, B6, B7, B8, C1, C2, C3, C4, D1, D2, D3, D4
128 GB	Sixteen 8 GB	A1, A2, A3, A4, B1, B2, B3, B4, C1, C2, C3, C4, D1, D2, D3, D4
192 GB	Twenty-four 8 GB	A1, A2, A3, A4, A5, A6, A7, A8, B1, B2, B3, B4, B5, B6, B7, B8, C1, C2, C3, C4, D1, D2, D3, D4

\*If 64 GB of memory is installed, the system will only recognize 63.75 GB during POST.

## Non-Optimal Memory Configurations

System performance can be affected if your memory configuration does not conform to the preceding installation guidelines. Your system may issue an error message during startup stating that your memory configuration is non-optimal.

## Memory Sparing Support - PowerEdge M905

Memory sparing (spare bank) is supported in systems that have one of the memory configurations shown in Table 3-2. The memory sparing feature must also be enabled in the **Memory Information** screen of the System Setup program. See "Memory Information Screen" on page 83. To use memory sparing, you must disable node interleaving.

**Table 3-2. Memory Sparing Configurations - PowerEdge M905**

<b>Total System Memory</b>	<b>Usable System Memory</b>	<b>Memory Modules - Number and Size</b>	<b>Memory Module Locations</b>
16 GB	12 GB	Eight 2 GB	A1, A2, B1, B2, C1, C2, D1, D2
32 GB	28 GB	Sixteen 2 GB	A1, A2, A3, A4, B1, B2, B3, B4, C1, C2, C3, C4, D1, D2, D3, D4
64 GB	56 GB	Sixteen 4 GB	A1, A2, A3, A4, B1, B2, B3, B4, C1, C2, C3, C4, D1, D2, D3, D4
128 GB	112 GB	Sixteen 8 GB	A1, A2, A3, A4, B1, B2, B3, B4, C1, C2, C3, C4, D1, D2, D3, D4

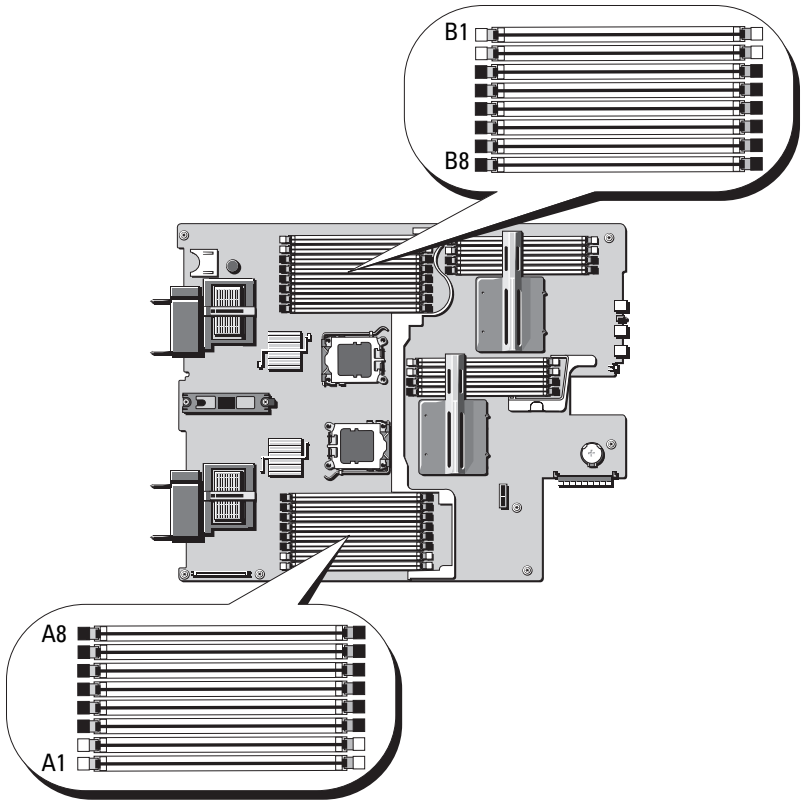
## System Memory - PowerEdge M805

You can upgrade your system memory to a maximum of 128 GB by installing 667-MHz registered DDR2 memory modules in sets of 1-GB, 2-GB, 4-GB, or 8-GB memory modules. (Dual-rank 8-GB modules are supported; quad-rank 8-GB modules are not supported.) Each processor has four memory channels, organized in sets of two channels.



**NOTICE:** If more than four memory modules are installed per processor, the memory modules will be downclocked to operate at 533 Mhz.

**Figure 3-8. Memory Locations - PowerEdge M805**



**General Memory Module Installation Guidelines - PowerEdge M805**

To ensure optimal performance of your system, observe the following guidelines when installing your system memory.

- Memory modules must be installed in pairs of identically-sized DIMMs, beginning with slots A1 and A2 (processor 1) and B1 and B2. These slots are marked by white ejector tabs.
- All memory modules in the blade must be identical in speed and technology. The memory modules in each pair must be the same size.

- Memory must be installed in the same configuration (symmetrically) for both processors.
- If pairs of memory modules of different sizes are installed, the larger capacity memory modules must be installed in the lower numbered slots.
- Memory sparing is supported if eight or sixteen memory modules are installed. (Memory mirroring is not supported.)

Table 3-3 shows examples of supported memory configurations.



**NOTICE:** Memory module blanks must be installed in unoccupied memory sockets to maintain proper cooling airflow.

**Table 3-3. Examples of PowerEdge M805 Memory Configurations**

<b>Total System Memory</b>	<b>Memory Modules - Number and Size</b>	<b>Memory Module Locations</b>
4 GB	Four 1 GB	A1, A2, B1, B2
8 GB	Eight 1 GB	A1, A2, A3, A4, B1, B2, B3, B4
8 GB	Four 2 GB	A1, A2, B1, B2
12 GB	Twelve 2 GB	A1, A2, A3, A4, A5, A6, B1, B2, B3, B4, B5, B6
16 GB	Sixteen 1 GB	A1, A2, A3, A4, A5, A6, A7, A8, B1, B2, B3, B4, B5, B6, B7, B8
16 GB	Eight 2 GB	A1, A2, A3, A4, B1, B2, B3, B4
16 GB	Four 4 GB	A1, A2, B1, B2
24 GB	Twelve 2 GB	A1, A2, A3, A4, A5, A6, B1, B2, B3, B4, B5, B6
32 GB	Sixteen 2 GB	A1, A2, A3, A4, A5, A6, A7, A8, B1, B2, B3, B4, B5, B6, B7, B8
32 GB	Eight 4 GB	A1, A2, A3, A4, B1, B2, B3, B4
48 GB	Twelve 4 GB	A1, A2, A3, A4, A5, A6, B1, B2, B3, B4, B5, B6
64 GB*	Sixteen 4 GB	A1, A2, A3, A4, A5, A6, A7, A8, B1, B2, B3, B4, B5, B6, B7, B8
64 GB*	Eight 8 GB	A1, A2, A3, A4, B1, B2, B3, B4

**Table 3-3. Examples of PowerEdge M805 Memory Configurations (continued)**

<b>Total System Memory</b>	<b>Memory Modules - Number and Size</b>	<b>Memory Module Locations</b>
128 GB	Sixteen 8 GB	A1, A2, A3, A4, A5, A6, A7, A8, B1, B2, B3, B4, B5, B6, B7, B8

\*If 64 GB of memory is installed, the system will only recognize 63.75 GB during POST.

### Non-Optimal Memory Configurations

System performance can be affected if your memory configuration does not conform to the preceding installation guidelines. Your system may issue an error message during startup stating that your memory configuration is non-optimal.

### Memory Sparing Support - PowerEdge M805

Memory sparing (spare bank) is supported in systems that have one of the memory configurations shown in Table 3-4. The memory sparing feature must also be enabled in the **Memory Information** screen of the System Setup program. See "Memory Information Screen" on page 83. To use memory sparing, you must disable node interleaving.

**Table 3-4. Memory Sparing Configurations - PowerEdge M805**

<b>Total System Memory</b>	<b>Usable System Memory</b>	<b>Memory Modules - Number and Size</b>	<b>Memory Module Locations</b>
16 GB	12 GB	Eight 2 GB	A1, A2, A3, A4, B1, B2, B3, B4
32 GB	28 GB	Sixteen 2 GB	A1, A2, A3, A4, A5, A6, A7, A8, B1, B2, B3, B4, B5, B6, B7, B8
64 GB	56 GB	Sixteen 4 GB	A1, A2, A3, A4, A5, A6, A7, A8, B1, B2, B3, B4, B5, B6, B7, B8
128 GB	112 GB	Sixteen 8 GB	A1, A2, A3, A4, A5, A6, A7, A8, B1, B2, B3, B4, B5, B6, B7, B8

## System Memory - PowerEdge M600

You can upgrade your system memory to a maximum of 32 GB by installing 667-MHz registered DDRII fully-buffered DIMMs (FBDs). 512-MB, 1-GB, 2-GB, 4-GB, and 8-GB memory modules are supported.

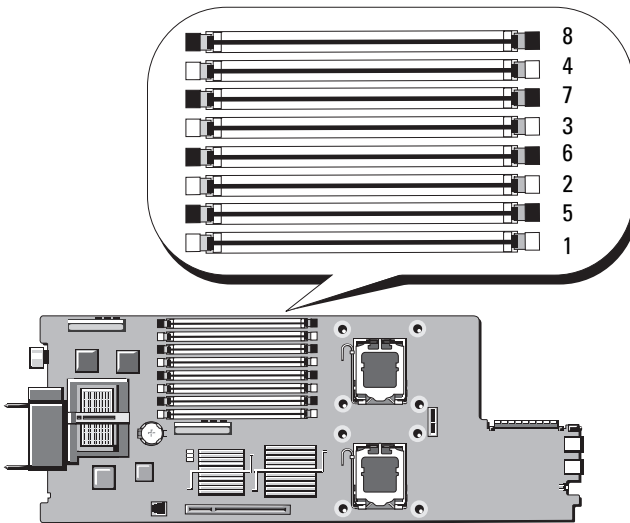
The memory module sockets are divided into two equal branches (0 and 1). Each branch consists of two channels and each channel consists of two memory module sockets:

- Branch 0, Channel 0 consists of slot 1 and slot 5.
- Branch 0, Channel 1 consists of slot 2 and slot 6.
- Branch 1, Channel 2 consists of slot 3 and slot 7.
- Branch 1, Channel 3 consists of slot 4 and slot 8.

The first DIMM socket of each channel has white release tabs.

Figure 3-9 shows the locations of the memory module sockets.

**Figure 3-9. Memory Locations - PowerEdge M600**





## General Memory Module Installation Guidelines - PowerEdge M600

To ensure optimal performance of your system, observe the following guidelines when configuring your system memory.

- Memory modules must be installed in pairs of identically-sized DIMMs. The total number of memory modules must equal two, four, or eight. Six modules are not supported.
- All memory modules in the blade must be identical in speed and technology. The memory modules in each pair must be the same size. For best system performance, all memory modules should be identical memory size, speed, and technology.
- Memory sparing and memory mirroring require eight memory modules of identical size, speed, and technology. Memory sparing and memory mirroring cannot be implemented at the same time.

Table 3-5 shows examples of supported memory configurations.



**NOTICE:** Memory module blanks must be installed in unoccupied memory sockets to maintain proper cooling airflow.

**Table 3-5. Examples of Memory Configurations - PowerEdge M600**

Total Memory	DIMM							
	1	2	3	4	5	6	7	8
1 GB	512 MB	512 MB	blank	blank	blank	blank	blank	blank
2 GB	512 MB	512 MB	512 MB	512 MB	blank	blank	blank	blank
2 GB	1 GB	1 GB	blank	blank	blank	blank	blank	blank
4 GB	512 MB	512 MB	512 MB	512 MB	512 MB	512 MB	512 MB	512 MB
4 GB	1 GB	1 GB	1 GB	1 GB	blank	blank	blank	blank
8 GB	1 GB	1 GB	1 GB	1 GB	1 GB	1 GB	1 GB	1 GB
8 GB	2 GB	2 GB	2 GB	2 GB	blank	blank	blank	blank
16 GB	2 GB	2 GB	2 GB	2 GB	2 GB	2 GB	2 GB	2 GB
16GB	4 GB	4 GB	4 GB	4 GB	blank	blank	blank	blank
32 GB	4 GB	4 GB	4 GB	4 GB	4 GB	4 GB	4 GB	4 GB

### Non-Optimal Memory Configurations

System performance can be affected if your memory configuration does not conform to the preceding installation guidelines. Your system may issue an error message during startup stating that your memory configuration is non-optimal.

### Memory Sparing Support - PowerEdge M600

Memory sparing requires eight identical memory modules. The memory sparing feature must also be enabled in the System Setup program, and can be used only if memory mirroring is not enabled.

Table 3-6 shows how memory sparing splits the available and spared memory in each memory module configuration.

**Table 3-6. Memory Sparing Configurations - PowerEdge M600**

DIMMs	Size/Type	Total Memory	Available	Spare
8	512-MB	4 GB	2 GB	2 GB
8	1-GB single-rank	8 GB	4 GB	4 GB
8	2-GB dual-rank	16 GB	12 GB	4 GB
8	4-GB dual-rank	32 GB	24 GB	8 GB

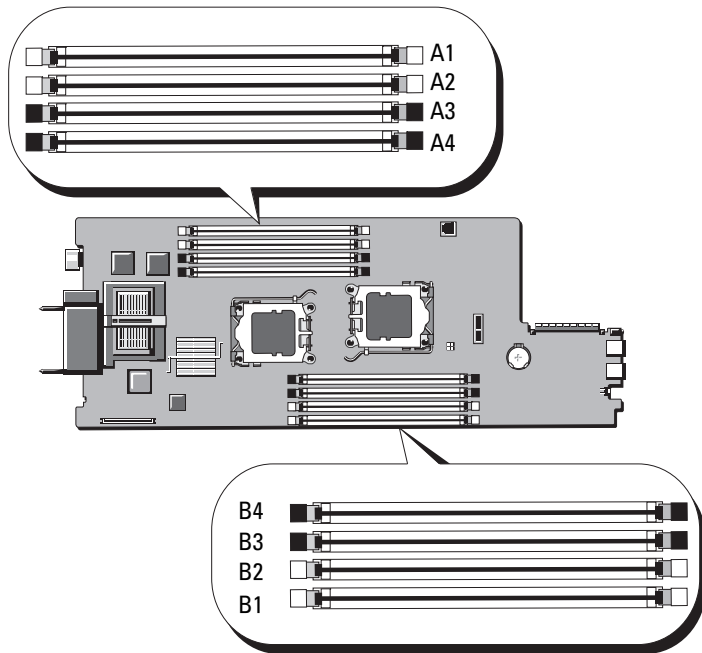
### Memory Mirroring Support - PowerEdge M600

The system supports memory mirroring if eight identical memory modules are installed in the system. Mirroring must be enabled in the System Setup program and can be used only if memory sparing is not enabled. In a mirrored configuration, the total available system memory is one-half of the total installed memory.

### System Memory - PowerEdge M605

You can upgrade your system memory to a maximum of 16 GB (single processor) or 32 GB (dual processors) by installing 667- or 800-MHz registered DDR2 memory modules in sets of 512-MB, 1-GB, 2-GB, 4-GB, or 8-GB modules. Each processor has four memory channels, organized in sets of two channels.

**Figure 3-10. Memory Locations - PowerEdge M605**




### **General Memory Module Installation Guidelines - PowerEdge M605**

To ensure optimal performance of your system, observe the following guidelines when installing your system memory.

- Memory modules must be installed in pairs of identically-sized DIMMs, beginning with slots A1 and A2 (processor 1) and B1 and B2 (processor 2, if installed). These slots are marked by white ejector tabs.
- All memory modules in the blade must be identical in speed and technology. The memory modules in each pair must be the same size.
- In two-processor configurations, memory must be installed in the same configuration (symmetrically) for both processors.
- If pairs of memory modules of different sizes are installed, the larger capacity memory modules must be installed in the lower numbered slots.
- Memory sparing is supported if four (single-processor systems) or eight (dual-processor systems) memory modules are installed.

Table 3-7 and Table 3-8 show examples of supported single- and dual-processor memory configurations.

**Single-Processor Memory Configurations**

 **NOTICE:** Memory module blanks must be installed in unoccupied memory sockets to maintain proper cooling airflow.

**Table 3-7. Single-Processor Memory Configurations - PowerEdge M605**

Total System Memory	CPU 1			
	A1	A2	A3	A4
1 GB	512 MB	512 MB	blank	blank
2 GB	512 MB	512 MB	512 MB	512 MB
2 GB	1 GB	1 GB	blank	blank
4 GB	1 GB	1 GB	1 GB	1 GB
4 GB	2 GB	2 GB	blank	blank
6 GB	2 GB	2 GB	1 GB	1 GB
8 GB	2 GB	2 GB	2 GB	2 GB
8 GB	4 GB	4 GB	blank	blank
12 GB	4 GB	4 GB	2 GB	2 GB
16 GB	4 GB	4 GB	4 GB	4 GB
32 GB	8 GB	8 GB	8 GB	8 GB

## Dual-Processor Memory Configurations



**NOTICE:** Memory module blanks must be installed in unoccupied memory sockets to maintain proper cooling airflow.

**Table 3-8. Dual-Processor Memory Configurations - PowerEdge M605**

Total System Memory	CPU1				CPU2			
	A1	A2	A3	A4	B1	B2	B3	B4
2 GB	512 MB	512 MB	blank	blank	512 MB	512 MB	blank	blank
4 GB	512 MB	512 MB	512 MB	512 MB	512 MB	512 MB	512 MB	512 MB
4 GB	1 GB	1 GB	blank	blank	1 GB	1 GB	blank	blank
6 GB	1 GB	1 GB	512 MB	512 MB	1 GB	1 GB	512 MB	512 MB
8 GB	1 GB	1 GB	1 GB	1 GB	1 GB	1 GB	1 GB	1 GB
8 GB	2 GB	2 GB	blank	blank	2 GB	2 GB	blank	blank
12 GB	2 GB	2 GB	1 GB	1 GB	2 GB	2 GB	1 GB	1 GB
16 GB	2 GB	2 GB	2 GB	2 GB	2 GB	2 GB	2 GB	2 GB
16 GB	4 GB	4 GB	blank	blank	4 GB	4 GB	blank	blank
24 GB	4 GB	4 GB	2 GB	2 GB	4 GB	4 GB	2 GB	2 GB
32 GB	4 GB	4 GB	4 GB	4 GB	4 GB	4 GB	4 GB	4 GB
64 GB*	8 GB	8 GB	8 GB	8 GB	8 GB	8 GB	8 GB	8 GB

\*If 64 GB of memory is installed, the system will only recognize 63.75 GB during POST.

### Non-Optimal Memory Configurations

System performance can be affected if your memory configuration does not conform to the preceding installation guidelines. Your system may issue an error message during startup stating that your memory configuration is non-optimal.

## Memory Sparing Support - PowerEdge M605

Memory sparing is supported in single- or dual-processor systems that have one of the fully populated memory configurations shown in Table 3-9. The memory sparing feature must be enabled in the **Memory Information** screen of the System Setup program. See "Memory Information Screen" on page 83. To use memory sparing, you must disable node interleaving.

Memory sparing allocates only the first rank of memory of a DIMM. For a single-rank DIMM, the entire capacity of the DIMM must be allocated for sparing along with the adjacent single-rank DIMM to spare a memory channel. For dual-rank DIMMs, two DIMMs are also required for sparing, but as only the first rank of each DIMM is allocated, only half of a dual-rank DIMM's capacity is allocated for sparing. The second ranks on both DIMMs are available memory. Table 3-9 shows how memory sparing splits the available and spared memory in each memory module configuration.

**Table 3-9. Memory Sparring Configurations - PowerEdge M605**

Processor 1				Processor 2				Available Memory	Spared Memory
DIMM 1	DIMM 2	DIMM 3	DIMM 4	DIMM 5	DIMM 6	DIMM 7	DIMM 8	1 CPU / 2 CPUs	1 CPU / 2 CPUs
512 MB	512 MB	512 MB	512 MB	512 MB	512 MB	512 MB	512 MB	1 GB / 2 GB	1 GB / 2 GB
1 GB	1 GB	512 MB	512 MB	1 GB	1 GB	512 MB	512 MB	1 GB / 2 GB	2 GB / 4 GB
1 GB	1 GB	1 GB	1 GB	1 GB	1 GB	1 GB	1 GB	2 GB / 4 GB	2 GB / 4 GB
2 GB	2 GB	512 MB	512 MB	2 GB	2 GB	512 MB	512 MB	3 GB / 6 GB	2 GB / 4 GB
2 GB	2 GB	1 GB	1 GB	2 GB	2 GB	1 GB	1 GB	4 GB / 8 GB	2 GB / 4 GB
2 GB	2 GB	2 GB	2 GB	2 GB	2 GB	2 GB	2 GB	6 GB / 12 GB	2 GB / 4 GB
4 GB	4 GB	512 MB	512 MB	4 GB	4 GB	512 MB	512 MB	5 GB / 10 GB	4 GB / 8 GB
4 GB	4 GB	1 GB	1 GB	4 GB	4 GB	1 GB	1 GB	6 GB / 12 GB	4 GB / 8 GB
4 GB	4 GB	2 GB	2 GB	4 GB	4 GB	2 GB	2 GB	8 GB / 16 GB	4 GB / 8 GB
4 GB	4 GB	4 GB	4 GB	4 GB	4 GB	4 GB	4 GB	12 GB / 24 GB	4 GB / 8 GB

Indicates a spared single-rank DIMM (512-MB or 1-GB). The entire capacity of this DIMM is reserved for sparing.

Indicates a spared dual-rank DIMM (2-GB and higher). One-half of this DIMM's capacity is reserved for sparing.

## Installing Memory Modules



**CAUTION:** Only trained service technicians are authorized to remove the system cover and access any of the components inside the system. Before you begin this procedure, review the safety instructions that came with the system.

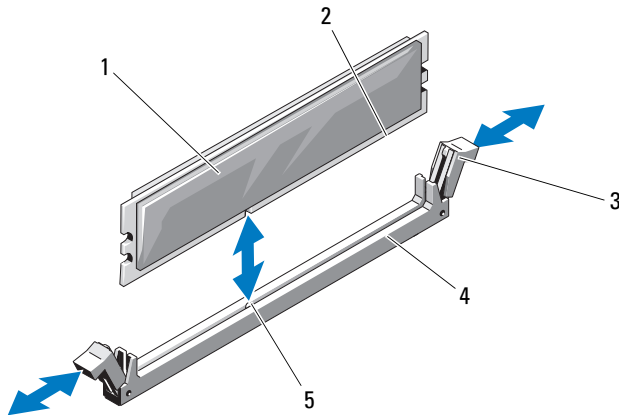


**CAUTION:** The memory modules are hot to the touch for some time after the blade has been powered down. Allow time for the memory modules to cool before handling them. Handle the memory modules by the card edges and avoid touching the components.

- 1 Remove the blade. See "Removing a Blade" on page 96.
- 2 Open the blade. See "Opening the Blade" on page 100.
- 3 Locate the memory module sockets. See Figure 7-3 or Figure 7-4.
- 4 *PowerEdge 905 systems only* - You must slide the system board back in the blade chassis to access memory sockets C1 through C4 and D1 through D4. See step 1 through step 7 in "Removing the System Board" on page 150.
- 5 Press the ejectors on the memory module socket down and out, as shown in Figure 3-11, to allow the memory module to be inserted into the socket. If a memory module blank is installed in the socket, remove it.




**Figure 3-11. Installing and Removing a Memory Module or Memory Module Blank**



- |   |               |   |                |
|---|---------------|---|----------------|
| 1 | memory module | 2 | edge connector |
| 3 | ejectors (2)  | 4 | socket         |
| 5 | alignment key |   |                |

- 6 Align the memory module's edge connector with the alignment key on the memory module socket, and insert the memory module in the socket.

 **NOTE:** The memory module socket has an alignment key that allows you to install the memory module in the socket in only one way.

- 7 Press down on the memory module with your thumbs to lock the memory module into the socket.

When the memory module is properly seated in the socket, the ejectors on the memory module socket align with the ejectors on the other sockets that have memory modules installed.

- 8 Repeat step 5 through step 7 of this procedure to install the remaining memory modules. See Table 3-5, Table 3-7, or Table 3-8 for sample memory configurations.

- 9 *PowerEdge 905 systems only* - If you removed the system board to access the memory modules, reinstall the system board.

- 10 Close the blade. See "Closing the Blade" on page 104.

- 11 Install the blade. See "Installing a Blade" on page 98.

- 12 (Optional) Press <F2> to enter the System Setup program, and check the **System Memory** setting on the main **System Setup** screen.

The system should have already changed the value to reflect the newly installed memory.

- 13 If the value is incorrect, one or more of the memory modules may not be installed properly. Repeat step 1 through step 12 of this procedure, checking to ensure that the memory modules are firmly seated in their sockets.
- 14 Run the system memory test in the system diagnostics. See "Running System Diagnostics" on page 197.

## Removing Memory Modules



**CAUTION: Only trained service technicians are authorized to remove the system cover and access any of the components inside the system. Before you begin this procedure, review the safety instructions that came with the system.**



**CAUTION: The DIMMs are hot to the touch for some time after the blade has been powered down. Allow time for the DIMMs to cool before handling them. Handle the DIMMs by the card edges and avoid touching the DIMM components.**

- 1 Remove the blade. See "Removing a Blade" on page 96.
- 2 Open the blade. See "Opening the Blade" on page 100.
- 3 Locate the memory module sockets. See Figure 7-3 or Figure 7-4.
- 4 *PowerEdge 905 systems only* - You must slide the system board back in the blade chassis to access memory sockets C1 through C4 and D1 through D4. See step 1 through step 7 in "Removing the System Board" on page 150.
- 5 Press down and out on the ejectors on each end of the socket until the memory module pops out of the socket. See Figure 3-11.
- 6 *PowerEdge 905 systems only* - If you removed the system board to access the memory modules, reinstall the system board.
- 7 Close the blade. See "Closing the Blade" on page 104.
- 8 Install the blade. See "Installing a Blade" on page 98.

# I/O Module Mezzanine Cards

The blades support a variety of optional mezzanine cards. If installed, the mezzanine card(s) must be used in conjunction with a matching appropriate I/O module(s). (For more information on I/O modules, see "Guidelines for Installing I/O Modules" on page 42.)

## Mezzanine Card Installation Guidelines

### PowerEdge M905 and M805

The full-height PowerEdge M905 and M805 blades support up to four mezzanine cards.

- Slot 1 and slot 3 support Fabric C. If a card is installed in both slots, both cards must be identical. They must also match the fabric type of the I/O modules installed in I/O module bays C1 and C2.
- Slot 2 and slot 4 support Fabric B. If a card is installed in both slots, both cards must be identical. They must also match the fabric type of I/O module installed in I/O module bays B1 and B2.



**NOTE:** The four mezzanine card slots do not need to be fully populated.

If a blade does require support by a particular fabric and only two external I/O port connections are needed, only one mezzanine card is required. For example, a Fibre Channel I/O module in I/O bay C1 or C2 only requires one Fibre Channel mezzanine card in slot 1 or slot 3 in the blade.

If a blade does not require support from a particular fabric, a mezzanine card is not required in either of the corresponding mezzanine card slots.

### PowerEdge M600 and M605

The half-height PowerEdge M600 and M605 blades support two mezzanine cards:

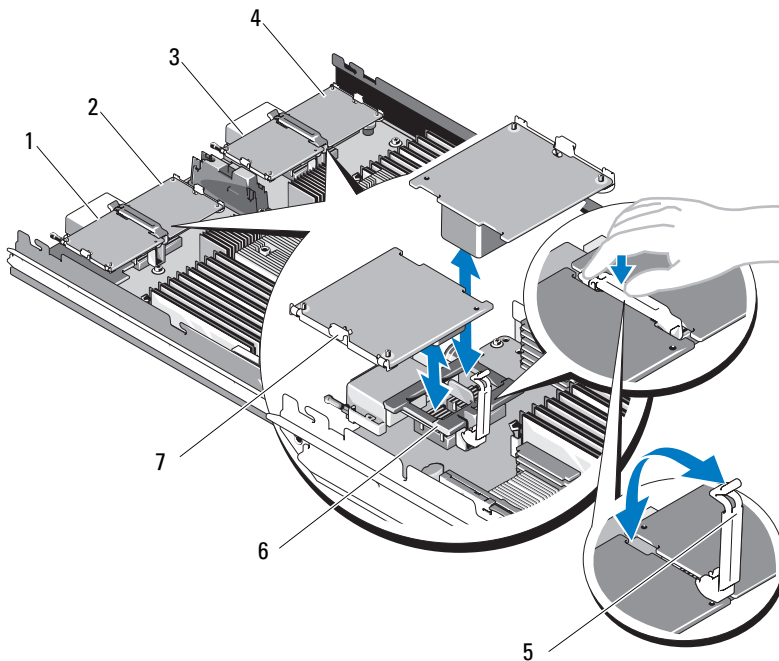
- Mezzanine card slot C supports Fabric C. This card must match the fabric type of I/O modules installed in I/O module bays C1 and C2.
- Mezzanine card slot B supports Fabric B. This card must match the fabric type of I/O modules installed in I/O module bays B1 and B2.

## Installing a Mezzanine Card

**⚠ CAUTION:** Many repairs may only be done by a certified service technician. You should only perform troubleshooting and simple repairs as authorized in your product documentation, or as directed by the online or telephone service and support team. **Damage due to servicing that is not authorized by Dell is not covered by your warranty. Read and follow the safety instructions that came with the product.**

- 1 Remove the blade. See "Removing a Blade" on page 96.
- 2 Open the blade. See "Opening the Blade" on page 100.
- 3 Open the mezzanine card latch by pressing the ridged area on the latch with your thumb and lifting the end of the latch. See Figure 3-12 or Figure 3-13.

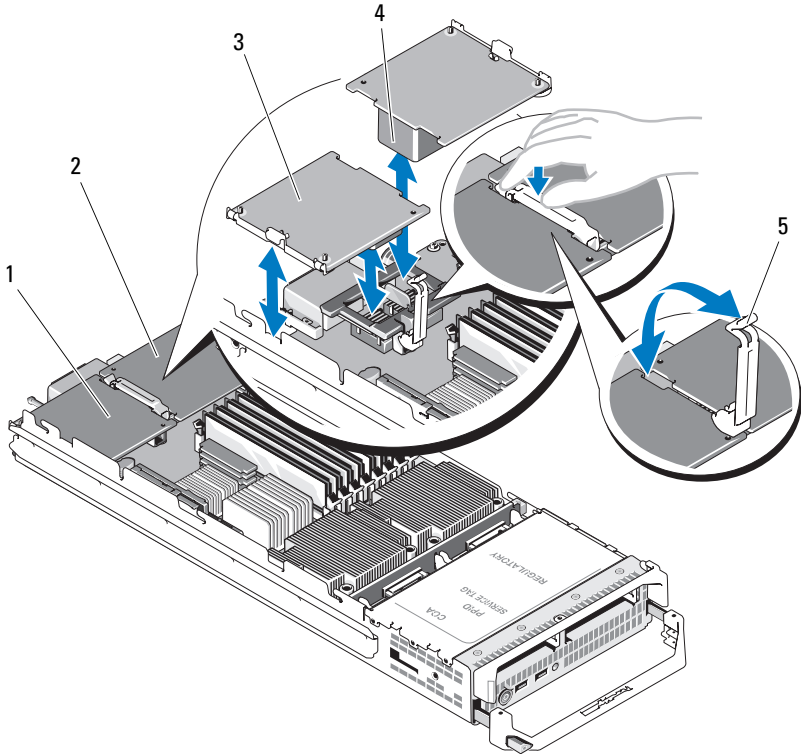
**Figure 3-12. Installing and Removing a Mezzanine Card - Full-Height Blades**



- |   |                                    |   |                                    |
|---|------------------------------------|---|------------------------------------|
| 1 | optional Fabric C mezzanine card 1 | 2 | optional Fabric B mezzanine card 2 |
| 3 | optional Fabric C mezzanine card 3 | 4 | optional Fabric B mezzanine card 4 |

- 5 retention latch
- 6 mezzanine card connector
- 7 mezzanine card

**Figure 3-13. Installing and Removing a Mezzanine Card - Half-Height Blades**



- 1 Fabric C mezzanine card slot
- 2 Fabric B mezzanine card slot
- 3 mezzanine card
- 4 mezzanine card connector
- 5 retention latch

4 If present, remove the connector cover from the mezzanine card bay.

**NOTICE:** Hold the mezzanine card by its edges only.

- 5 Mezzanine cards are designed to fit in either card slot. Rotate the card to align the connector on the bottom of the mezzanine card with the corresponding socket on the blade board.
- 6 Lower the card into place until it is fully seated and the plastic clip on the outer edge of the card fits over the side of the blade chassis.
- 7 Close the retention latch to secure the mezzanine card.
- 8 Close the blade. See "Closing the Blade" on page 104.
- 9 Install the blade. See "Installing a Blade" on page 98.

### Removing a Mezzanine Card



**CAUTION:** Only trained service technicians are authorized to remove the system cover and access any of the components inside the system. Before you begin this procedure, review the safety instructions that came with the system.

- 1 Remove the blade. See "Removing a Blade" on page 96.
- 2 Open the blade. See "Opening the Blade" on page 100.
- 3 Open the mezzanine card latch by pressing the ridged area on the latch with your thumb, and lifting the end of the latch. See Figure 3-13.



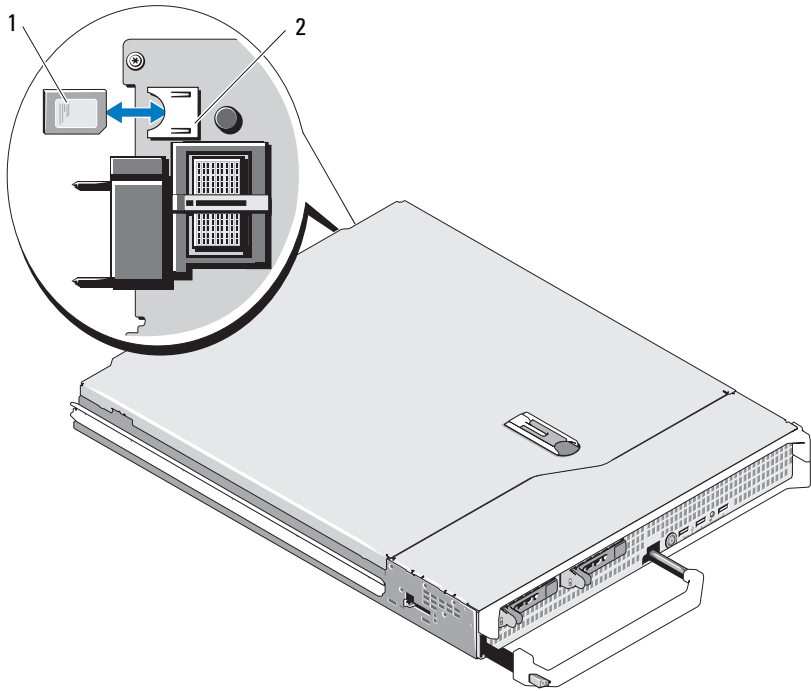
**NOTICE:** Hold the mezzanine card by its edges only.

- 4 Lift up the mezzanine card straight up from the system board.
- 5 Close the retention latch.
- 6 Close the blade. See "Closing the Blade" on page 104.
- 7 Install the blade. See "Installing a Blade" on page 98.

## Installing an SD Card (PowerEdge M905 and M805)

Locate the SD card slot on the system board and insert the contact-pin end of the card into the slot with the label on the card facing upwards. See Figure 3-14.

**Figure 3-14. Installing an SD Card (PowerEdge M805 and M905 Only)**



1 SD card

2 SD card connector

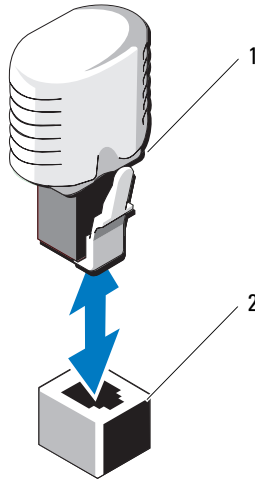
## Integrated NIC Hardware Key

TOE, iSCSI, and other future functionality for the blade's integrated NICs is enabled by installing a NIC hardware key in the TOE\_KEY socket on the system board (see Figure 7-3 or Figure 7-4.)



**NOTE:** TOE Operating system support and the Microsoft scalable network pack are required for TOE functionality.


**Figure 3-15. Installing a NIC Hardware Key**



1 NIC hardware key

2 connector on system board

## Processors

 **NOTE:** The following removal and installation procedures apply to the PowerEdge M905, M805, M605, and M600 blades. Appropriate illustrations are provided for each type of processor.

### Processor Installation Guidelines

#### PowerEdge 905 Systems

- The PowerEdge 905 supports dual-core or quad-core AMD™ Opteron™ 8xxx Series processors only.
- Four processors must be installed; dual-processor configurations are not supported
- Only AMD 8xxx MP series processors are supported.



### PowerEdge 805 Systems

- The PowerEdge 805 supports dual-core or quad-core AMD Opteron 2xxx Series processors only.
- In a PowerEdge 805 system, two processors must be installed; a single-processor configuration is not supported.
- Hypertransport (HT) bridge cards must be installed in sockets CPU3 and CPU4. See "HT Bridge Card (Service Only)" on page 138.

### PowerEdge 605 Systems

- The PowerEdge 605 supports dual-core or quad-core AMD Opteron 2xxx MP Series processors only.
- Both single and dual-processor configurations are supported.

### PowerEdge 600 Systems

- The PowerEdge 600 supports dual-core or quad-core Intel® Xeon® processors only.
- Both single and dual-processor configurations are supported.

## Removing a Processor



**CAUTION:** Only trained service technicians are authorized to remove the system cover and access any of the components inside the system. Before you begin this procedure, review the safety instructions that came with the system.

- 1 Remove the blade. See "Removing a Blade" on page 96.
- 2 Open the blade. See "Opening the Blade" on page 100.



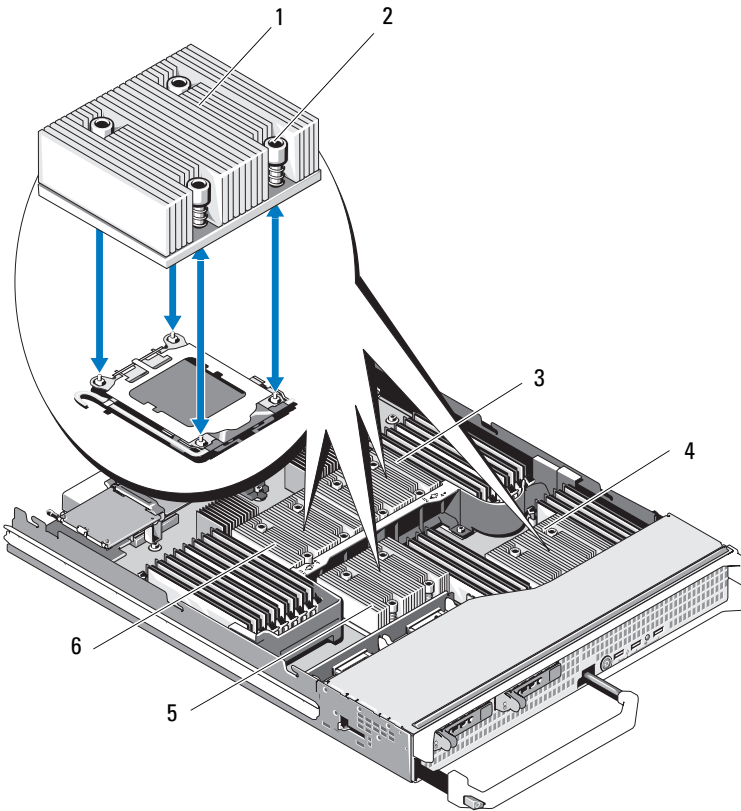
**CAUTION:** The processor and heat sink can become extremely hot. Be sure the processor has had sufficient time to cool before handling.



**NOTICE:** Never remove the heat sink from a processor unless you intend to remove the processor. The heat sink is necessary to maintain proper thermal conditions.

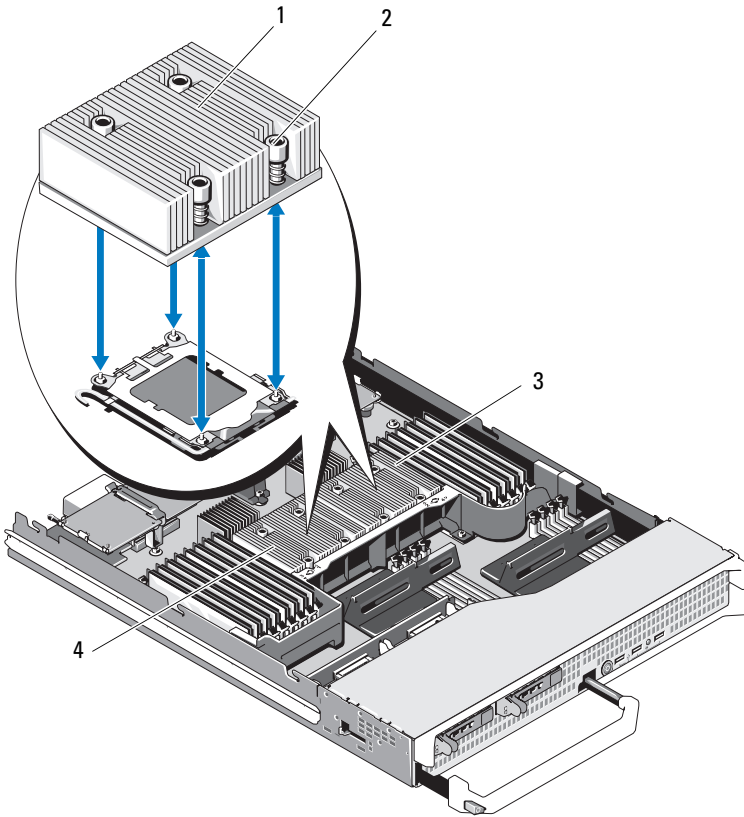
- 3 Loosen the four screws that secure the heat sink to the system board. See Figure 3-16 (PowerEdge M905), Figure 3-17 (PowerEdge M805), Figure 3-18 (PowerEdge M600) or Figure 3-19 (PowerEdge M605).

**Figure 3-16. Installing and Removing the Heat Sink (PowerEdge M905)**



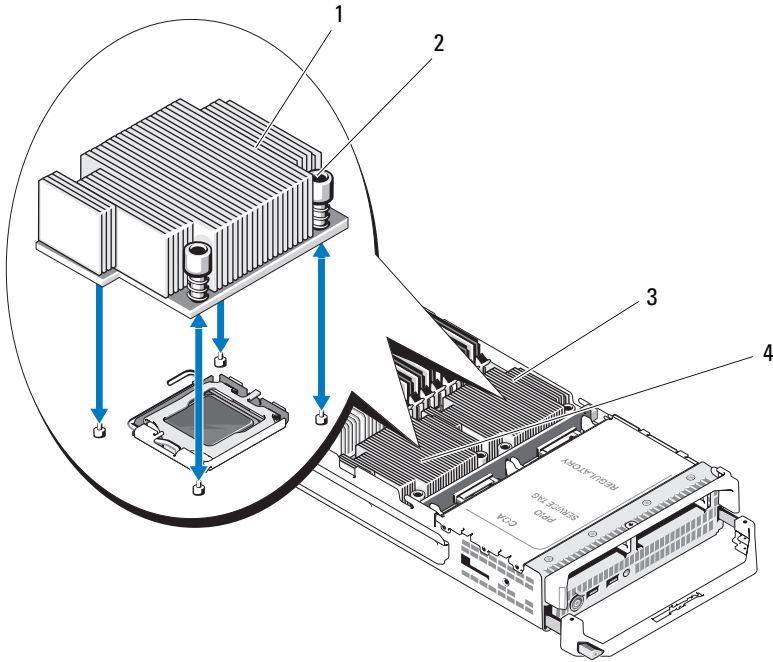
- |   |             |   |             |
|---|-------------|---|-------------|
| 1 | heat sink   | 2 | screws (4)  |
| 3 | socket CPU2 | 4 | socket CPU4 |
| 5 | socket CPU3 | 6 | socket CPU1 |
- You must install the heatsink in the orientation shown here.

**Figure 3-17. Installing and Removing a Heat Sink (PowerEdge M805)**



- |   |   |   |             |
|---|---|---|-------------|
| 1 | heat sink<br>You must install the heatsink in the orientation shown here. | 2 | screws (4)  |
| 3 | socket CPU2   | 4 | socket CPU1 |

**Figure 3-18. Installing and Removing a Heat Sink (PowerEdge M600)**



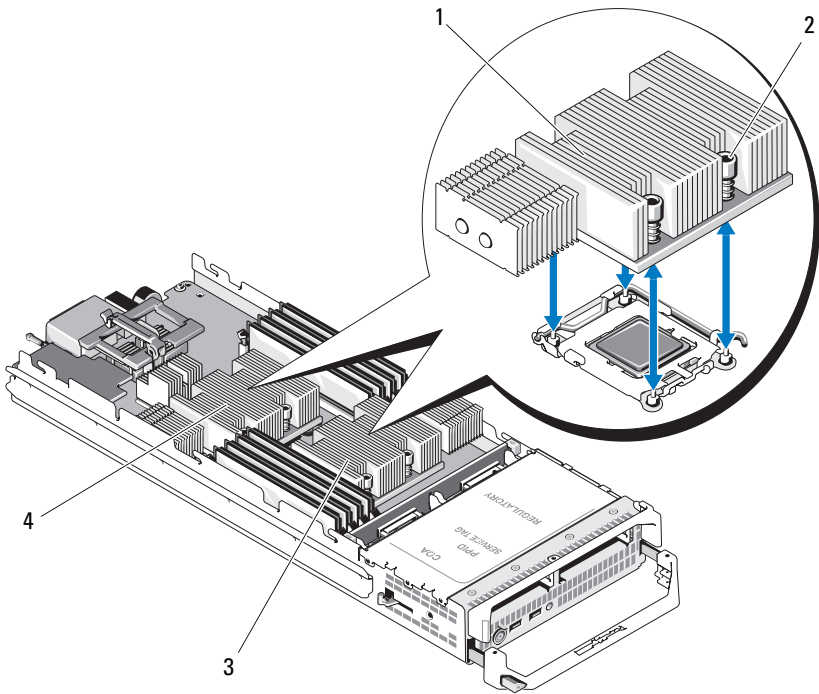
1 heat sink

2 screws (4)

3 socket CPU1

4 socket CPU2

**Figure 3-19. Installing and Removing a Heat Sink (PowerEdge M605)**



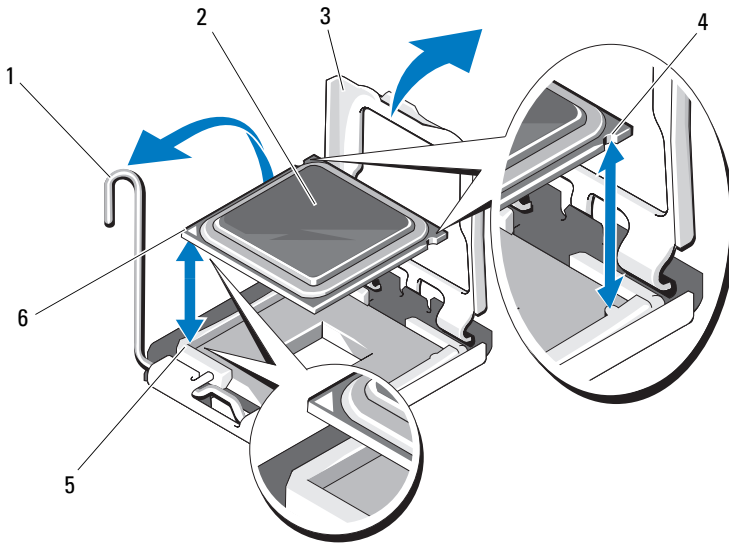
- |   |             |   |             |
|---|-------------|---|-------------|
| 1 | heat sink   | 2 | screws (4)  |
| 3 | socket CPU2 | 4 | socket CPU1 |

**4** Remove the heat sink.

Set the heat sink upside down on the work surface to avoid contaminating the thermal grease.

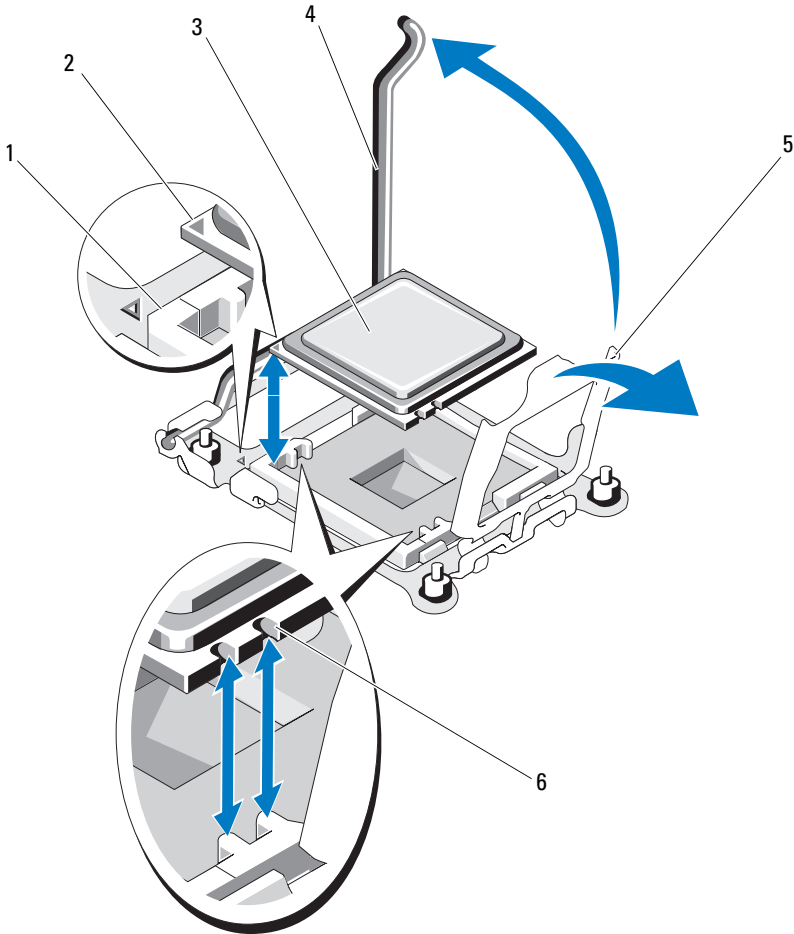
- 5** Use a clean lint-free cloth to remove any thermal grease from the surface of the processor shield.
- 6** Pull the socket-release lever straight up until the processor is released from the socket. See Figure 3-20 (PowerEdge M600) or Figure 3-21 (PowerEdge M905, M805, or M605).

**Figure 3-20. Installing and Removing an Intel Processor (PowerEdge M600)**



- |   |                        |   |                           |
|---|------------------------|---|---------------------------|
| 1 | socket-release lever   | 2 | processor                 |
| 3 | processor shield       | 4 | notch in processor        |
| 5 | pin-1 corner of socket | 6 | pin-1 corner of processor |

**Figure 3-21. Installing and Removing an AMD Processor (PowerEdge M905, M805, or M605)**



- |   |                        |   |                           |
|---|------------------------|---|---------------------------|
| 1 | pin-1 corner of socket | 2 | pin-1 corner of processor |
| 3 | processor              | 4 | socket-release lever      |
| 5 | processor shield       | 6 | notch in processor        |

- 7 Open the processor shield and then lift the processor out of the socket. Leave the release lever up so that the socket is ready for the new processor.

## Installing a Processor

- 1 If you are adding a processor to an unoccupied socket, perform the following steps first.



**NOTE:** If you are installing just one processor, it must be installed in socket CPU1. See Figure 7-3 or Figure 7-4.

- a Remove the processor filler blank
  - b Lift the plastic processor socket cover from the socket.
  - c Unlatch and rotate the socket-release lever 90 degrees upward.
  - d Lift the processor shield.
- 2 Install the processor in the socket. See Figure 3-20 (PowerEdge M600) or Figure 3-21 (PowerEdge M905, M805, or M605).



**NOTE:** Positioning the processor incorrectly can permanently damage the processor and the system board when you turn it on. Be careful not to bend the pins on the LGA socket.

- a Identify the pin-1 corner of the processor by locating the tiny gold triangle on one corner of the processor. Place this corner in the same corner of the ZIF socket identified by a corresponding triangle on the system board. Align the pin-1 corner of the processor with the pin-1 corner of the ZIF socket. See Figure 3-20 (PowerEdge M600) or Figure 3-21 (PowerEdge M905, M805, or M605).
- b Ensure that the socket-release lever is fully open.
- c With the pin-1 corners of the processor and socket aligned, set the processor lightly in the socket.  
Because the system uses a ZIF processor socket, do not use force. When the processor is positioned correctly, it drops down into the socket with minimal pressure.
- d Close the processor shield.
- e Rotate the socket release lever down until it snaps into place, securing the processor.



**3** Install the heat sink. See Figure 3-18 (PowerEdge M600) or Figure 3-19 (PowerEdge M905, M805, or M605).

- a** *If you are reinstalling a heat sink*, use a clean lint-free cloth to remove the existing thermal grease from the heat sink.

If you are upgrading a processor and a new heat sink was supplied with the processor, install the new heat sink.

*If you are reinstalling a processor*, also clean any remnants of thermal grease from the processor.

- b** Apply thermal grease evenly to the top of the processor.
- c** Place the heat sink onto the processor.

The heat sink *must* match the orientation shown in Figure 3-16 (PowerEdge M905), Figure 3-17 (PowerEdge M805), Figure 3-18 (PowerEdge M600) or Figure 3-19 (PowerEdge M605).



**NOTE:** Do not over-tighten the heat sink retention screws when installing the heat sink. To prevent over-tightening, tighten the retention screw until resistance is felt and stop once the screw is seated. The screw tension should be no more than 6 in-lb (6.9 kg-cm).

- d** Carefully tighten the four screws to secure the heat sink to the blade board.

**4** Close the blade. See "Closing the Blade" on page 104.

**5** Install the blade. See "Installing a Blade" on page 98.

As the system boots, it detects the presence of the new processor and automatically changes the system configuration information in the System Setup program.

**6** Press <F2> to enter the System Setup program, and check that the processor information matches the new system configuration.

See "Using the System Setup Program" on page 79 for instructions about using the System Setup program.

**7** Run the system diagnostics to verify that the new processor operates correctly.

See "Running System Diagnostics" on page 197 for information about running the diagnostics and troubleshooting processor problems.

**8** Update the system BIOS.

## HT Bridge Card (Service Only)

An HT (hypertransport) bridge card must be installed in the third and fourth CPU sockets on the PowerEdge M805 system board.

Consequently, if you replace the system board, you must transfer the HT bridge cards to the replacement planar.

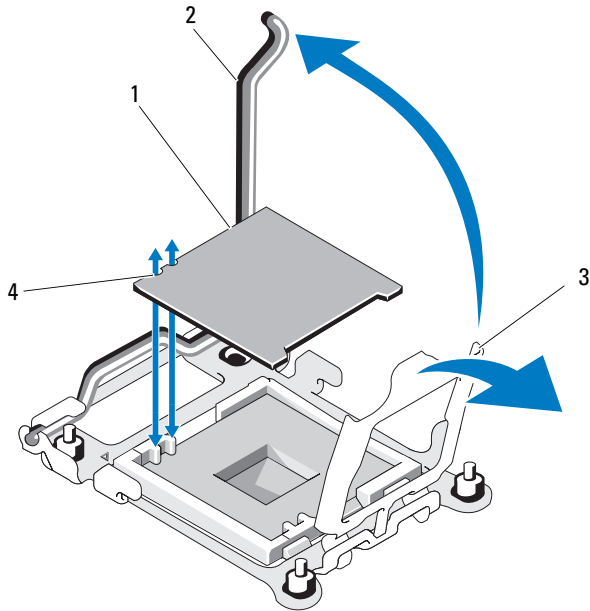
### Removing an HT Bridge Card



**CAUTION: Only trained service technicians are authorized to remove the system cover and access any of the components inside the system. Before you begin this procedure, review the safety instructions that came with the system.**

- 1 Remove the blade. "Removing a Blade" on page 96.
- 2 Open the blade. See "Opening the Blade" on page 100.
- 3 Pull the socket-release lever straight up until the bridge card is released from the socket. See Figure 3-22.
- 4 Open the processor shield and then lift the card out of the socket.

**Figure 3-22. Installing and Removing an HT Bridge Card (PowerEdge M805 Only)**



- |   |                  |   |                      |
|---|------------------|---|----------------------|
| 1 | HT bridge card   | 2 | socket-release lever |
| 3 | processor shield | 4 | notch in card        |

### **Installing an HT Bridge Card**

- 1** Perform the following steps to prepare the two sockets on the new system board:
  - a** Remove the processor filler blank
  - b** Lift the plastic processor socket cover from the socket.
  - c** Unlatch and rotate the socket-release lever 90 degrees upward.
  - d** Lift the processor shield.
  - e** Repeat steps a through d to prepare the second processor socket.

- 2 Install the bridge card in the socket. See Figure 3-22.



**NOTE:** Positioning the card incorrectly can permanently damage the card and the system board when you turn the system on. Be careful not to bend the pins on the LGA socket.

- a Identify the pin-1 corner of the card by locating the tiny gold triangle on one corner of the card. Place this corner in the same corner of the ZIF socket identified by a corresponding triangle on the system board.
  - b Ensure that the socket-release lever is fully open.
  - c With the pin-1 corners of the card and socket aligned, set the processor lightly in the socket.  
Because the system uses a ZIF processor socket, do not use force. When the card is positioned correctly, it drops down into the socket with minimal pressure.
  - d Close the processor shield.
  - e Rotate the socket release lever down until it snaps into place, securing the card.
- 3 Close the blade. See "Closing the Blade" on page 104.
  - 4 Install the blade. See "Installing a Blade" on page 98.

## Blade System Board NVRAM Backup Battery

The NVRAM backup battery is a 3.0-volt (V), coin-cell battery.

### Removing and Installing the NVRAM Backup Battery



**CAUTION:** Only trained service technicians are authorized to remove the system cover and access any of the components inside the system. Before you begin this procedure, review the safety instructions that came with the system.

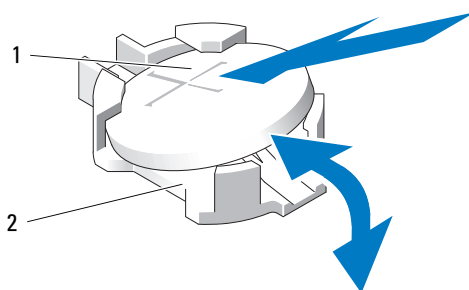


**CAUTION:** There is a danger of a new battery exploding if it is incorrectly installed. Replace the battery only with the same or equivalent type recommended by the manufacturer. Discard used batteries according to the manufacturer's instructions. See the safety instructions that came with your system for additional information.

- 1 Remove the blade. See "Removing a Blade" on page 96.
- 2 Open the blade. See "Opening the Blade" on page 100.

- 3 If you are replacing the battery in a PowerEdge M905, M805, or M605 system, you must remove the system board to access the battery. See "Blade System Board (Service Only)" on page 150.
- 4 Remove the battery by lifting it straight up from its connector. See Figure 3-23.  
See Figure 7-1 (PowerEdge M905), Figure 7-2 (PowerEdge M805), Figure 7-3 (PowerEdge M600), or Figure 7-4 (PowerEdge M605) to locate the battery on the blade board.
- 5 Install the new battery with the side labeled "+" facing up. See Figure 3-23.

**Figure 3-23. Replacing the NVRAM Backup Battery**



- |                       |                     |
|-----------------------|---------------------|
| 1 "+" side of battery | 2 battery connector |
|-----------------------|---------------------|

- 6 If you removed the system board to replace the battery, reinstall the board now. See "Blade System Board (Service Only)" on page 150.
- 7 Close the blade. See "Closing the Blade" on page 104.
- 8 Install the blade. See "Installing a Blade" on page 98.
- 9 Enter the System Setup program to confirm that the battery is operating properly. See "Using the System Setup Program" in your *User's Guide*.
- 10 Enter the correct time and date in the System Setup program's **Time** and **Date** fields.
- 11 Exit the System Setup program.

- 12 To test the newly installed battery, remove the blade for at least an hour. See "Removing a Blade" on page 96.
- 13 After an hour, reinstall the blade. See "Installing a Blade" on page 98.
- 14 Enter the System Setup program and if the time and date are still incorrect, see "Getting Help" on page 217 for instructions about obtaining technical assistance.

## Hard Drives

- The PowerEdge M805 and M905 blades support one or two hot-pluggable 2.5 inch SAS hard drives.
- The PowerEdge M600 and M605 blades support one or two hot-pluggable 2.5-inch SATA hard drives and one or two 2.5 inch SAS hard drives.



**NOTE:** SAS and SATA hard drives cannot be mixed within a blade.



**NOTE:** SATA hard drives are not hot pluggable with the SATA repeater daughter card.

### Hard-Drive Installation Guidelines

- If a SATA RAID controller storage card is installed, the blade supports hot-plug drive removal and installation.
- If only one hard drive is used, a blank must be installed to maintain proper cooling.

### Installing a Hard Drive



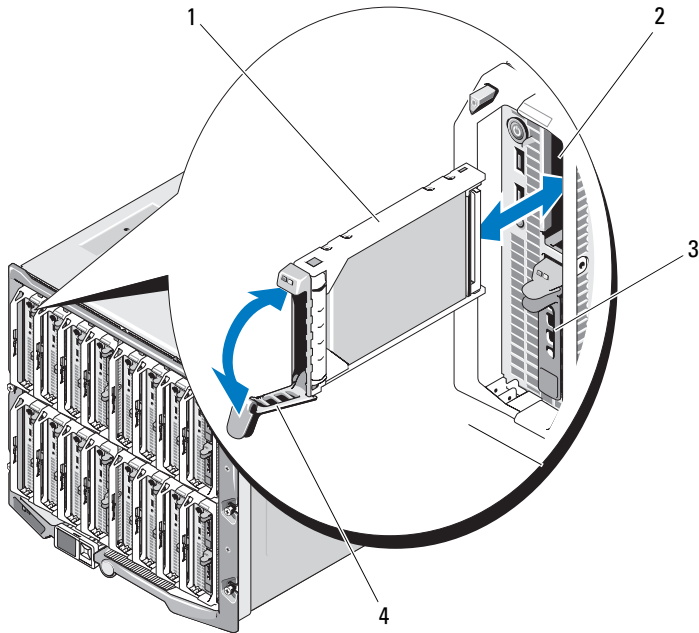
**NOTICE:** When a replacement hot-pluggable hard drive is installed and the blade is powered on, the hard drive automatically begins to rebuild. Make absolutely sure that the replacement hard drive is blank or contains data that you wish to have over-written. Any data on the replacement hard drive is immediately lost after the hard drive is installed.



**NOTICE:** Not all operating systems support hot-plug drive installation. See the documentation supplied with your operating system.

- 1 Open the hard-drive carrier handle. See Figure 3-24.

**Figure 3-24. Installing a Hard Drive (Half-Height Blade Shown)**



- |   |                    |   |                  |
|---|--------------------|---|------------------|
| 1 | hard drive carrier | 2 | hard drive bay 0 |
| 3 | hard drive bay 1   | 4 | carrier handle   |

- 2 Insert the hard-drive carrier into the drive bay.
- 3 Close the hard-drive carrier handle to lock it in place.

### Removing a Hard Drive

**NOTICE:** Not all operating systems support hot-plug drive installation. See the documentation supplied with your operating system.

- 1 Take the hard drive offline and wait until the hard-drive indicator codes on the drive carrier signal that the drive may be removed safely. See Figure 1-8.

When all indicators are off, the drive is ready for removal.

See your operating system documentation for more information on taking the hard drive offline.

- 2 Open the hard-drive carrier handle to release the drive. See Figure 3-24.
- 3 Slide the hard drive out until it is free of the drive bay.

If you are permanently removing the hard drive, install a blank insert.

### **Shutdown Procedure for Servicing a Hard Drive**



**NOTE:** This section applies only to situations where the blade must be powered down to service a hard drive. In many situations, the hard drive can be serviced while the blade is powered on.

If you need to power off the blade to service a hard drive, wait 30 seconds after the blade's power indicator turns off before removing the hard drive. Otherwise, the hard drive may not be recognized after the hard drive is reinstalled and the blade is powered on again.

### **Configuring the Boot Drive**

The drive or device from which the system boots is determined by the boot order specified in the System Setup program (see "Using the System Setup Program" on page 79).

### **Removing a Hard Drive From a Hard-Drive Carrier**

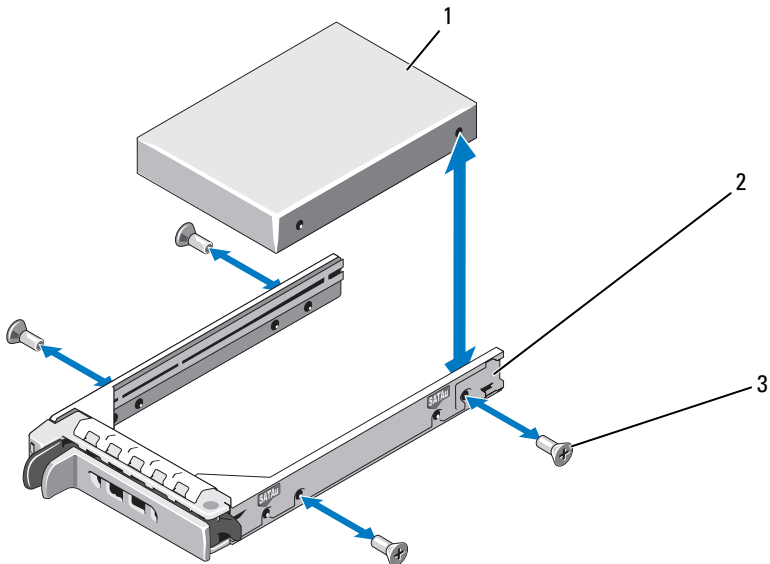
Remove the four screws from the slide rails on the hard-drive carrier and separate the hard drive from the carrier. See Figure 3-24.

### **Installing a Hard Drive In a Drive Carrier**

- 1 Insert the hard drive into the hard-drive carrier with the connector end of the drive at the back of the carrier. See Figure 3-24.
- 2 Align the screw holes on the hard drive with the holes on the hard-drive carrier.
- 3 Attach the four screws to secure the hard drive to the hard-drive carrier.



**Figure 3-25. Removing and Installing a Hard Drive In a Drive Carrier**



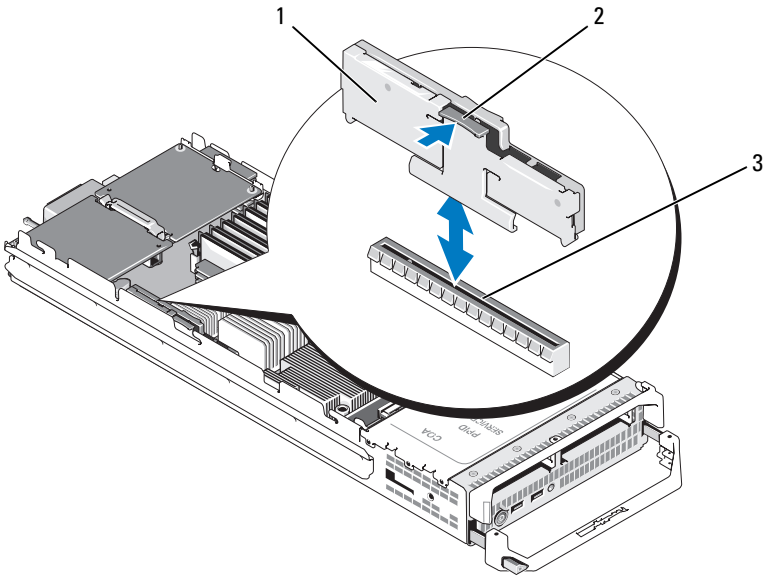
- |   |            |   |               |
|---|------------|---|---------------|
| 1 | hard drive | 2 | drive carrier |
| 3 | screws (4) |   |               |

## Video Controller

Follow these steps to replace the video controller.

- 1 Remove the blade. See "Removing a Blade" on page 96.
- 2 Open the blade. See "Opening the Blade" on page 100.
- 3 Remove the video controller:
  - If you are removing the video controller from a PowerEdge M600, press the latch on the upper edge of the video riser card, then lift the card from the blade. See Figure 3-26.
  - If you are removing the video controller from a PowerEdge M605, M805, or M905, remove the two torx screws securing the daughter card, then lift the card from the blade. See Figure 3-27.

**Figure 3-26. Removing and Installing a Video Riser Card (PowerEdge M600)**

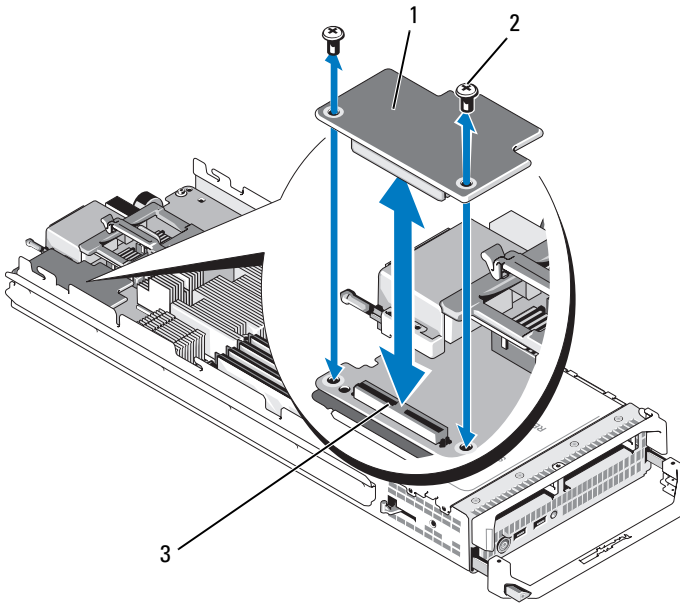


1 video riser card

2 latch

3 connector on system board

**Figure 3-27. Removing and Installing a Video Controller Daughter Card (PowerEdge M605 Shown)**



- |   |                           |   |                 |
|---|---------------------------|---|-----------------|
| 1 | video controller board    | 2 | torx screws (2) |
| 3 | connector on system board |   |                 |

**4** To install a new video controller:

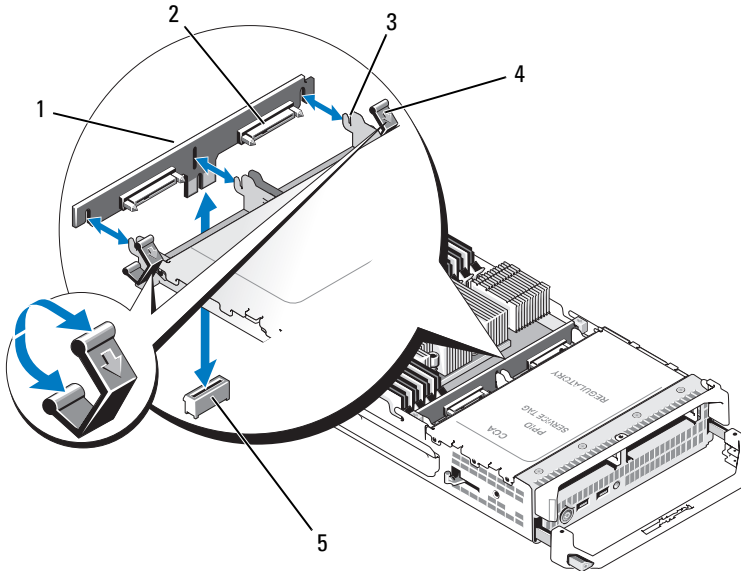
- *If you are installing a video controller in a PowerEdge M600, align the edge connector on the riser card with the connector on the system board, then lower the riser card into place until the connector is fully seated and the latch snaps into place. See Figure 3-26.*
- *If you are installing a video controller in a PowerEdge M605, align the connector on the underside of the controller card with the connector on the system board, then lower the card into place. Secure the card with the two screws. See Figure 3-27.*

# Hard-Drive Backplane

Follow these steps to remove and replace the hard-drive backplane.

- 1 Remove the blade. See "Removing a Blade" on page 96.
- 2 Open the blade. See "Opening the Blade" on page 100.
- ➔ **NOTICE:** If you are removing two hard drives, label them so you can replace them in their original locations.
- ➔ **NOTICE:** You must remove the hard drives before removing the backplane.
- 3 Remove the hard drive(s). See "Removing a Hard Drive" on page 143.
- 4 Lift the latches at each end of the backplane, then lift the backplane from the blade chassis. See Figure 3-28.

**Figure 3-28. Removing and Installing the Hard-Drive Backplane (PowerEdge M605 Shown)**



- |   |                                     |   |                           |
|---|-------------------------------------|---|---------------------------|
| 1 | hard-drive backplane                | 2 | hard-drive connectors (2) |
| 3 | retention hooks (3)                 | 4 | latches (2)               |
| 5 | backplane connector on system board |   |                           |

**5** To install the hard-drive backplane:

- a** Hold the backplane with the drive connectors facing towards the hard drive bays.
- b** Position the backplane so that the retention hooks on the end of the drive bay are aligned with the corresponding slots in the backplane.
- c** Press the backplane into place until the connector is fully seated and the latches at each end snap over the upper edge of the board.

**6** Replace the hard drive(s).

If you are installing two drives, be sure and reinstall them in their original locations.

- 7 Close the blade. See "Closing the Blade" on page 104.
- 8 Install the blade in the system. See "Installing a Blade" on page 98.


## Blade System Board (Service Only)


### Removing the System Board

 **CAUTION: Only trained service technicians are authorized to remove the system cover and access any of the components inside the system. Before you begin this procedure, review the safety instructions that came with the system.**

- 1 Remove the blade. See "Removing a Blade" on page 96.
- 2 Install an I/O connector cover on the I/O connector(s) at the back of the board.
- 3 Open the blade. See "Opening the Blade" on page 100.


 **CAUTION: The processor and heat sink can become extremely hot. Be sure the processor has had sufficient time to cool before handling.**

 **CAUTION: The memory modules are hot to the touch for some time after the system has been powered down. Allow time for the memory modules to cool before handling them. Handle the memory modules by the card edges and avoid touching the components.**

 **NOTICE:** If you are removing two hard drives, label them so you can replace them in their original locations.

- 4 Remove the hard drives. See "Removing a Hard Drive" on page 143.
- 5 Remove the hard-drive backplane. See "Hard-Drive Backplane" on page 148.
- 6 *For a PowerEdge M905 or M805 blade*, remove mezzanine cards 1 and 4 (the outermost mezzanine cards).

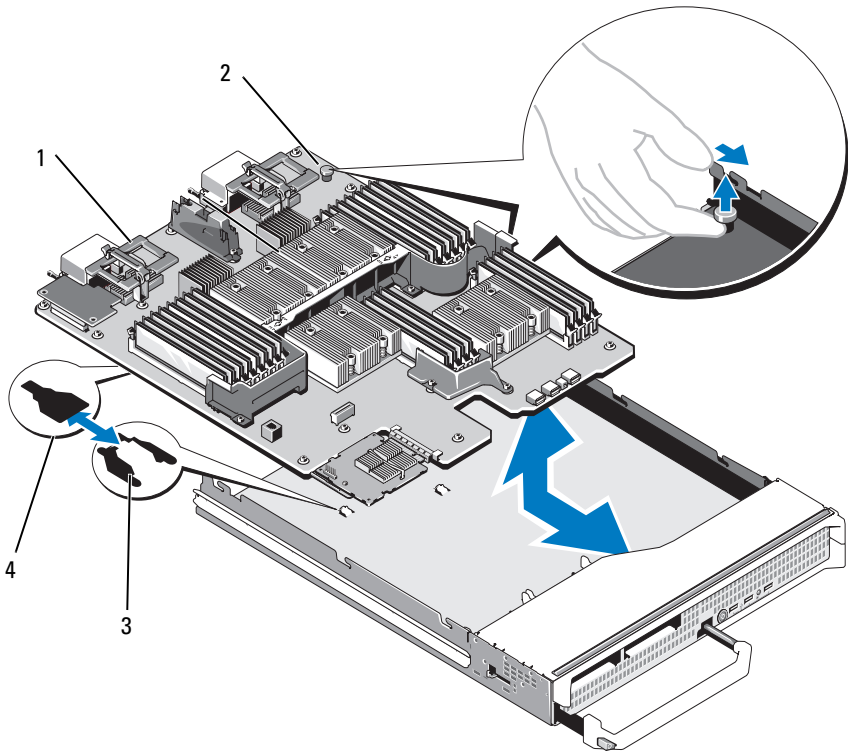
*For a PowerEdge M605 or M600 blade*, remove both mezzanine cards if present.

 **NOTICE:** If you are removing multiple mezzanine cards, label them so you can replace them in their original locations.

**7** To remove a full-height blade system board:

- a** Use the thumb and index fingers of your right hand to lift the system board retention pin. See Figure 3-29.
- b** Keeping the retention pin raised with your index finger, press the corner of the blade chassis with your thumb to slide the system board out of the open end of the chassis.

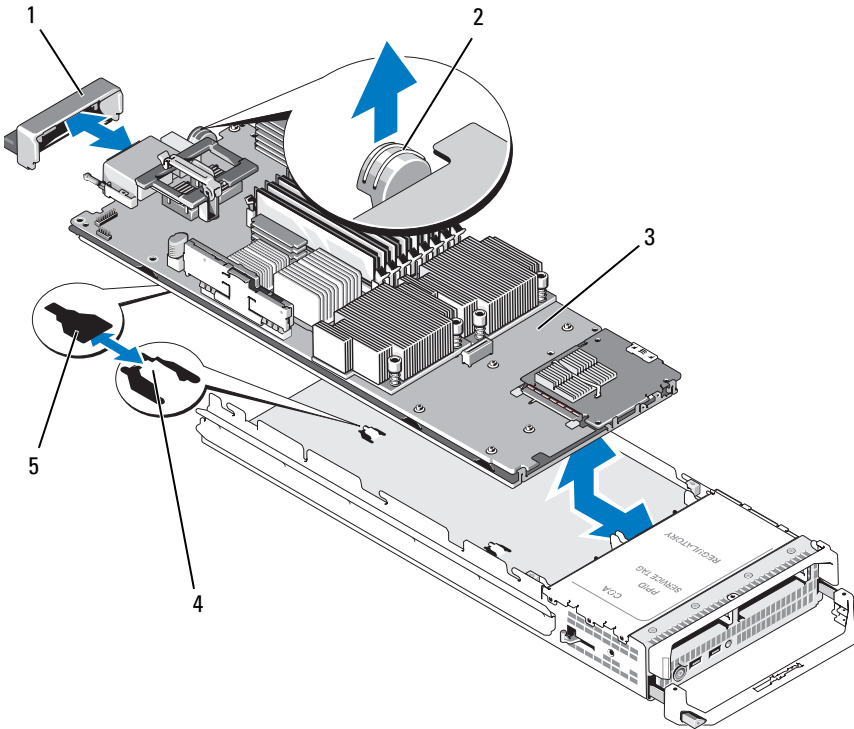
**Figure 3-29. Removing and Installing the System Board - Full-Height Blades**



- |   |                        |   |                            |
|---|------------------------|---|----------------------------|
| 1 | system board           | 2 | system board retention pin |
| 3 | tabs on system chassis | 4 | slots in system board tray |

To remove a half-height blade system board, hold the blade chassis with one hand, lift and pull the system board retention latch with the other hand, and then slide the system board out of the open end of the chassis. See Figure 3-30.

**Figure 3-30. Removing and Installing the System Board - Half-Height Blades**



- |   |                            |   |                        |
|---|----------------------------|---|------------------------|
| 1 | I/O connector cover        | 2 | retention latch        |
| 3 | system board               | 4 | tabs on system chassis |
| 5 | slots in system board tray |   |                        |

**NOTICE:** If you are removing multiple mezzanine cards, label them so you can replace them in their original locations.

- 8 Insure that the I/O connector cover is still in place on the I/O connector at the back of the board. See Figure 3-29 or Figure 3-30.



- 9 Remove the video riser card or daughter card. See "Video Controller" on page 145.
- 10 Remove the memory modules and memory module blanks. See "Removing Memory Modules" on page 122.
- 11 Remove the processor(s). See "Removing a Processor" on page 129.
- 12 Remove the storage controller board. See "Removing the Storage Controller Board" on page 154.
- 13 Remove the TOE or iSCSI activation key. See "System Board Connectors" on page 207 for the location of the key.

## Installing the System Board



**CAUTION:** Only trained service technicians are authorized to remove the system cover and access any of the components inside the system. Before you begin this procedure, review the safety instructions that came with the system.

- 1 Transfer the following components to the new system board:
  - TOE or iSCSI activation key. See "System Board Connectors" on page 207 for the location of the key.
  - Storage controller board. See "Installing the Storage Controller Board" on page 155.
  - Memory modules and memory module blanks. See "Installing Memory Modules" on page 120.
  - Processor(s) and heat sink(s), or processor filler blank. See "Installing a Processor" on page 136.
  - HT bridge cards (PowerEdge M805 only). See "HT Bridge Card (Service Only)" on page 138.
- 2 Slide the new system board into the open end of the blade chassis until the retention latch or retention pin engages.



**NOTE:** Ensure that the system board plate is parallel with the chassis.

When the board assembly is installed correctly, the tabs on the system board pan fit into the corresponding openings in the floor of the blade chassis. See Figure 3-29 or Figure 3-30.

- 3 Reinstall the video daughter card or video riser card. See "Video Controller" on page 145.

- 4 Replace the mezzanine card(s) in their original locations. See "Installing a Mezzanine Card" on page 124.
- 5 Reinstall the hard-drive backplane. See "Hard-Drive Backplane" on page 148.
- 6 Replace the hard drive(s).
  - *If there are two drives*, be sure and reinstall them in their original locations.
  - *If only one hard-drive is installed*, install it in bay 0.
- 7 Close the blade. See "Closing the Blade" on page 104.
- 8 Remove the plastic I/O connector covers from the back of the blade.
- 9 Install the blade in the system. See "Installing a Blade" on page 98.

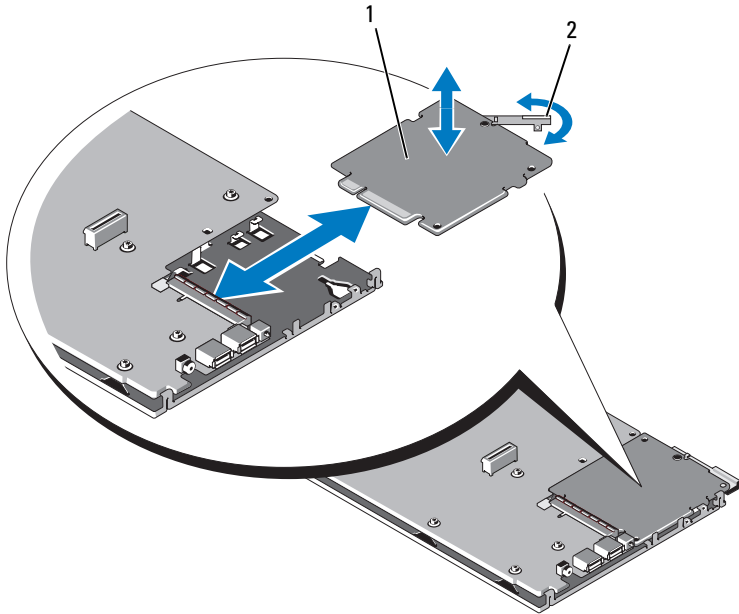
## Storage Controller Card (Service Only)

The storage controller board is located underneath the drive bays.

### Removing the Storage Controller Board

- 1 Remove the blade. See "Removing a Blade" on page 96.
- 2 Open the blade. See "Opening the Blade" on page 100.
- 3 Remove the system board and place it on the work surface. See "Removing the System Board" on page 150.
- 4 Open the release lever to disengage the controller board edge connector from the system board connector.
- 5 Lift the controller board straight up from the system board.

**Figure 3-31. Removing and Installing the Storage Controller Card (Half-Height Blade Shown)**



1 storage controller card

2 release lever

### **Installing the Storage Controller Board**

- 1 To place the storage controller board onto the system board, align the controller board so that the tabs on the metal system board tray fit through the corresponding notches in the edges of the controller board.
- 2 Slide the board towards the connector on the system board until the boards' edge connector is fully seated.
- 3 Reinstall the system board. See "Installing the System Board" on page 153.
- 4 Close the blade. See "Closing the Blade" on page 104.
- 5 Install the blade in the system. See "Installing a Blade" on page 98.




# Installing Enclosure Components


The procedures in this section describe how to remove and install components in the M1000e enclosure, including:

- Power supply modules
- Fan modules
- Chassis Management Controller (CMC) modules
- iKVM module
- I/O modules
- Blades
- Enclosure midplane (service-only procedure)
- Enclosure control panel assembly (service-only procedure)
- LCD panel (service-only procedure)

# Power Supply Modules

The M1000e enclosure supports up to six hot-pluggable power supply modules, accessible from the enclosure back panel.

 **NOTE:** The 2360-W power supply modules require 200–240 V input from a PDU. If the power supply modules are plugged into 110-V electrical outlets, the system will not power up.

 **NOTE:** In addition to supplying power to the system, the power supply modules also have internal fans that provide thermal cooling for the blades. A power supply module must be replaced if an internal fan failure occurs.


## System Power Guidelines

Your system has one of the following power supply configurations:

- Three 2360-W power supply modules, which do not provide redundancy if one power supply module fails. The power supplies are installed in bays 1 through 3.
- Six 2360-W power supply modules, which provide redundancy if up to three power supply modules fail.

The CMC module controls power management for the system. You can program the CMC to configure the power budget, redundancy, and dynamic power of the entire enclosure (chassis, servers, I/O modules, iKVM, CMC, and power supplies). The power management service optimizes power consumption and re-allocates power to different modules based on real-time demand. For more information, see "Power Management" in the *Dell Chassis Management Controller User's Guide*.

 **NOTE:** The wattage of a power supply module is listed on its regulatory label.

 **NOTICE:** PDU inlet cords for this system may be too thick to fit in the wire guides installed in the rack vertical rails. If this is the case, remove the wire guides by removing the attachment screw securing each guide. Route the PDU inlet cords along the vertical rails, securing them with tie wraps or Velcro strips.

## Power Supply Blanks

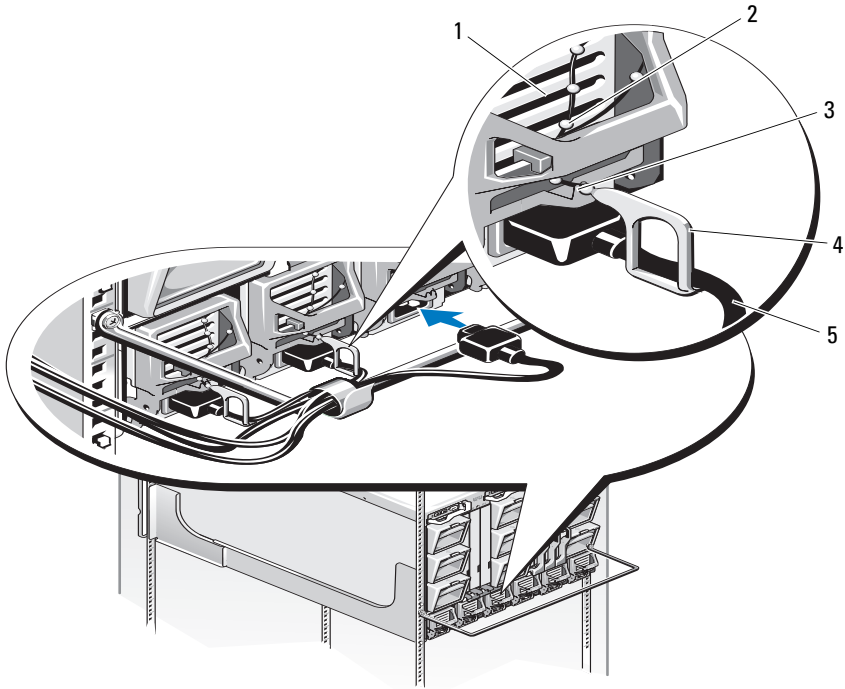
If the M1000e enclosure is operated with only three power supplies, power supply blanks must be installed in the three unoccupied power supply bays (4 through 6) to maintain proper cooling airflow in the enclosure.

## Removing a Power Supply Module

**➔ NOTICE:** The power supply modules are hot-pluggable. Remove and replace only one power supply module at a time in a system that is turned on.

- 1 Release the power cord retention clip and disconnect the power cord from the power supply module. See Figure 4-1.

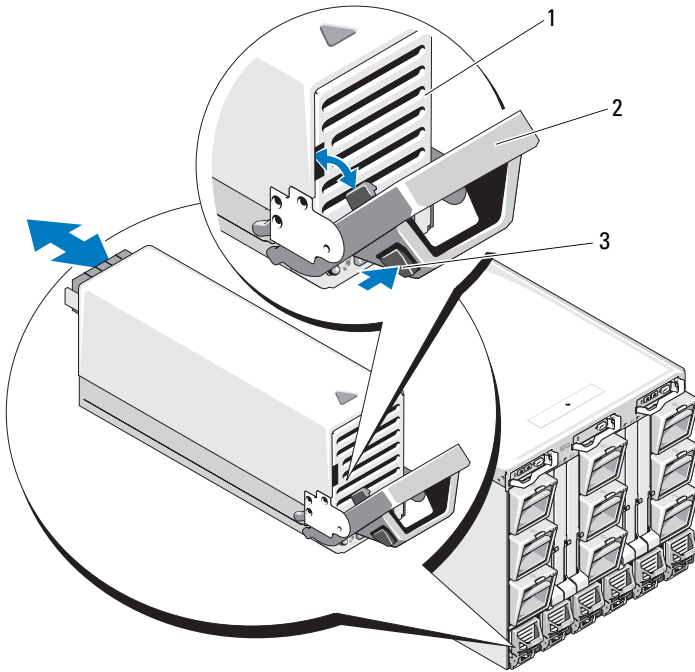
**Figure 4-1. Power Cable Retention Clip**



- |   |                              |   |                       |
|---|------------------------------|---|-----------------------|
| 1 | power supply                 | 2 | retention clip tether |
| 3 | notch in power supply handle | 4 | retention clip        |
| 5 | power cable                  |   |                       |

- 2 Press down on the power supply module release button on the handle. See Figure 4-2.

**Figure 4-2. Removing and Installing a Power Supply Module**



- 1 power supply
- 2 handle
- 3 release button

- 3 Rotate the power supply module handle down to eject the power supply module.
- 4 Slide the power supply module out of the enclosure.

### **Installing a Power Supply Module**

- 1 Ensure that the power-supply module handle is fully open, and then slide the power supply module into the enclosure. See Figure 4-2.
- 2 Rotate the power-supply module handle upward until it latches.
- 3 Plug a power cable into the power supply module.




- 4 Secure the cable to the power supply with the retention clip by fitting the retention clip over the cable, and fitting the retention clip tether into the notch in the power supply handle. See Figure 4-1.

## Fan Modules

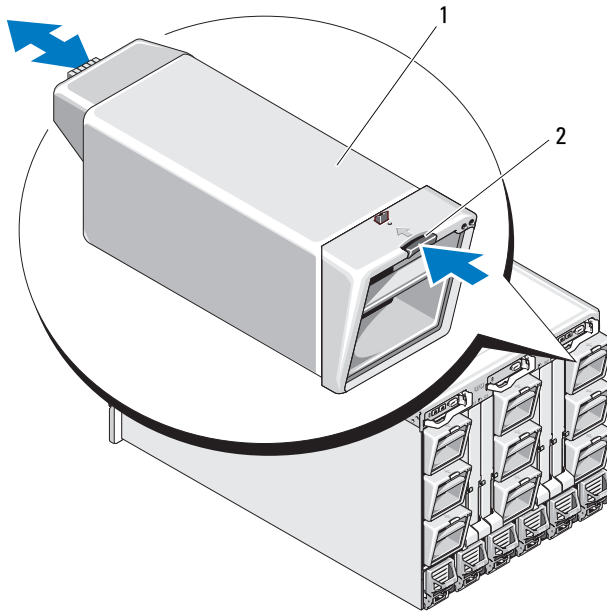
The M1000e enclosure contains nine hot-pluggable fan modules. All nine fan modules must be installed at all times to ensure proper cooling.

### Removing a Fan Module

 **NOTICE:** After a fan module is removed from the system, replace it immediately.

- 1 Identify the failed system fan module using the back-panel fan module indicators. See Figure 1-12.
- 2 Remove the fan module:
  - a Press the fan-module release button. See Figure 4-3.
  - b Slide the fan module out of the enclosure.

**Figure 4-3. Removing and Installing a Fan Module**



1 fan module

2 release button

### **Installing a Fan Module**

- 1 Inspect the fan for debris before installing the fan in the enclosure.
- 2 Slide the fan module into the enclosure until it is fully seated and the release button engages. See Figure 4-3.

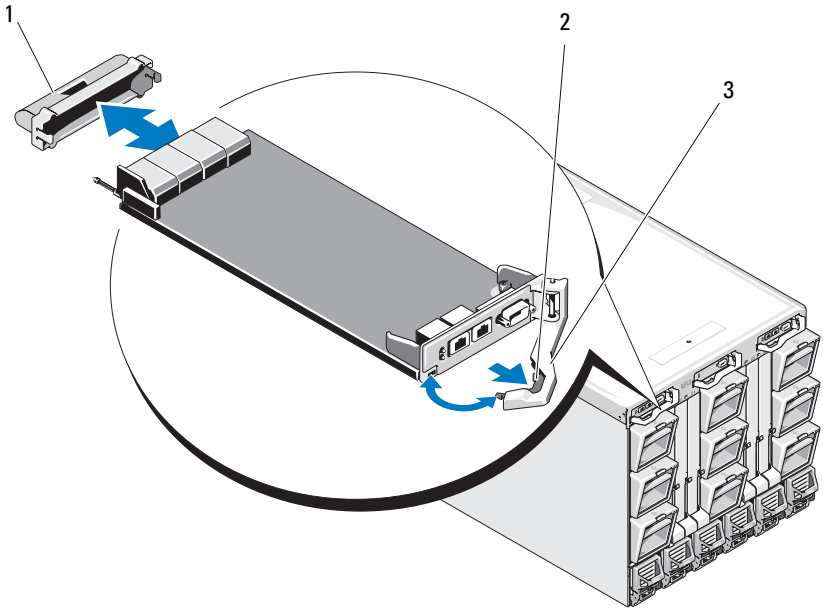
## **CMC Module**

### **Removing a CMC Module**

- 1 Disconnect the cables attached to the CMC module.
- 2 Press in the release latch on the handle and rotate the handle away from the module front panel.

- 3 Slide the CMC module out of the enclosure.
- 4 Install the I/O connector cover. See Figure 4-4.

**Figure 4-4. Removing and Installing a CMC Module or iKVM Module (CMC Module Shown)**




- 1 I/O connector cover
- 3 release lever


- 2 release latch

## Installing an SD Card in the CMC Module

The SD card slot on the CMCM module supports an optional WWN/MAC feature that allows slot-based WWN/MACs for the blades, simplifying blade installation and replacement.

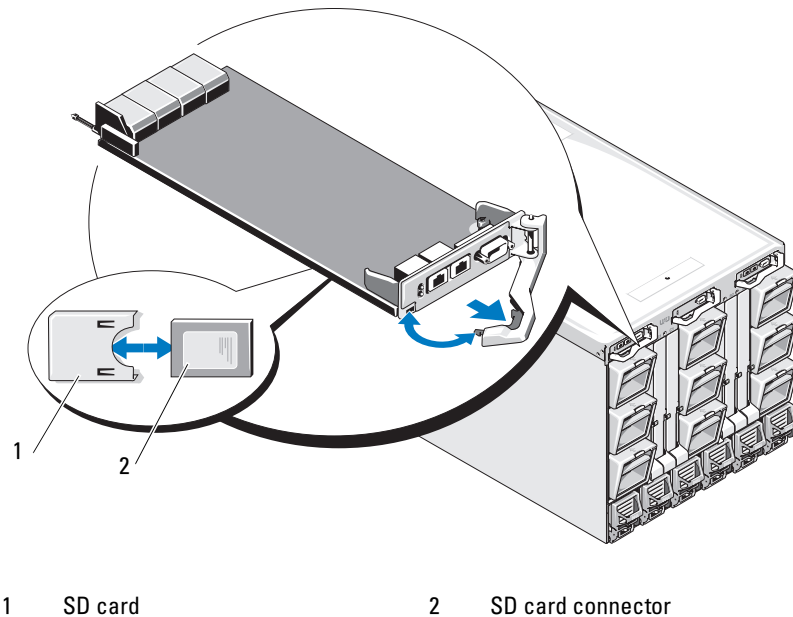
 **NOTE:** For a redundant CMC module system, install the SD card on the passive module. The blue status indicator will be off on the passive module.

- 1 Remove the CMC module from the M1000e enclosure. See "Removing a CMC Module" on page 162.

 **NOTE:** Verify the write protection latch is in the "unlock" position.

- 2 Locate the SD card slot on the bottom of the CMC module and insert the contact-pin end of the card into the slot with the label on the card facing upwards. See Figure 4-5.

**Figure 4-5. Installing an SD Card in the CMC Module**



- 3 Reinstall the CMC module and reattach any cables that were disconnected. See "Installing a CMC Module" on page 165.

On a single CMC system, the SD card will activate automatically. For redundant CMC module systems, initiate a changeover to make the passive module active using the following steps:

- 1 Navigate to the Chassis page.
- 2 Click the **Power Management** tab.
- 3 Click the **Control** sub tab.
- 4 Select the **Reset CMC (warm boot)** button.
- 5 Click **Apply**.

The CMC will automatically fail over to the redundant module, and that module will now become active and display a solid blue status LED. The SD card will activate automatically.

See the *CMC User's Guide* for information on configuration and usage of the FlexAddress feature.

## **Installing a CMC Module**

- 1 Remove the I/O connector cover. See Figure 4-4.
- 2 Ensure that the CMC module handle is fully open.
- 3 Slide the module into the enclosure until the handle contacts the enclosure.
- 4 To fully seat the module, close the handle until the release latch snaps into place.
- 5 Reconnect the cables that were attached to the module.

# iKVM Module

## Removing an iKVM Module

- 1 Disconnect the cables attached to the iKVM module.
- 2 Press in the release latch on the handle and rotate the handle away from the module front panel. See Figure 4-4.
- 3 Slide the module out of the enclosure.

## Installing an iKVM Module

- 1 Ensure that the module handle is fully open. See Figure 4-4.
- 2 Slide the module into the enclosure until the handle contacts the enclosure.
- 3 To fully seat the module, close the handle until the release latch snaps into place.
- 4 If applicable, connect the keyboard, monitor, and mouse to the module.

# I/O Modules

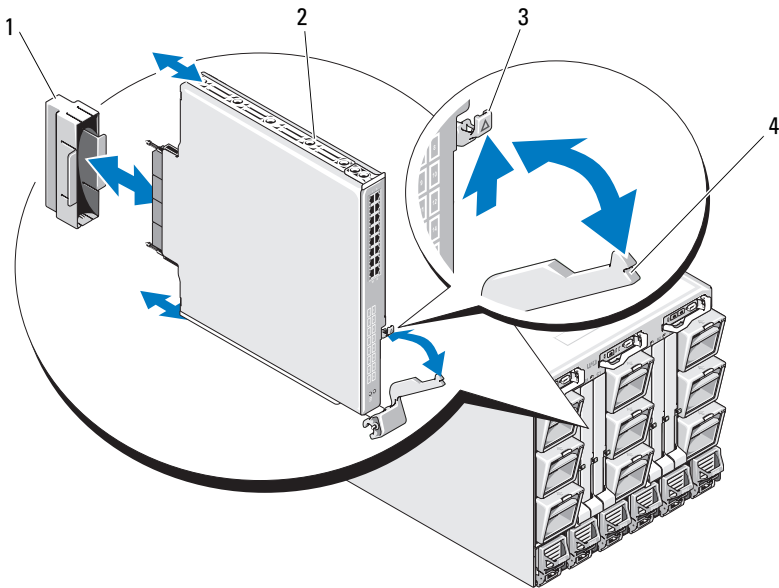


**NOTICE:** If you remove an I/O module, you must either replace it with another I/O module or with a filler blank to maintain cooling airflow through the system enclosure.

## Removing an I/O Module

- 1 If you have not already installed the cable enumerators to make removal and replacement of the I/O modules easier and faster, install them now. See the *Rack Installation Guide* for details.
- 2 Disconnect the cables attached to the I/O module.
- 3 Lift the latch on the end of the module's handle and rotate the handle away from the module. See Figure 4-6.
- 4 Slide the I/O module out of the enclosure.
- 5 Install the I/O connector cover.

**Figure 4-6. Removing and Installing an I/O Module**



- |   |                     |   |            |
|---|---------------------|---|------------|
| 1 | I/O connector cover | 2 | I/O module |
| 3 | release latch       | 4 | handle     |

### Installing an I/O Module

**➡ NOTICE:** The I/O module must be installed in the appropriate I/O bay. See "Guidelines for Installing I/O Modules" on page 42.

When installing I/O modules or blanks in the I/O module bays in the back of our system enclosure, you must install them in right-to-left order:

- A module (or blank) must be installed in bay A2, then bay B2, then bay C2.
- Next, a module (or blank) must be installed in bay C1, then bay B1, then bay A1.

**1** Unpack the I/O module and prepare it for installation.

For instructions, see the documentation that accompanied the I/O module.

- 2 Remove the I/O connector cover from the back of the module. See Figure 4-6.
- 3 Install the I/O module in the M1000e enclosure.
  - a Lift the handle release latch and open the I/O module handle.
  - b Slide the module into the enclosure.
  - c Close the handle until it snaps securely into place and the module is fully seated.
- 4 Connect all cables that must be attached to the I/O module.

See the documentation provided with the I/O module for information about its cable connections. See the *Rack Installation Guide* for information on using the cable enumerators to organize and manage the cables.
- 5 A matching fabric mezzanine card must be installed in one or more blades to support the new I/O module. If necessary, install the mezzanine card(s) now. See "I/O Module Mezzanine Cards" on page 123.

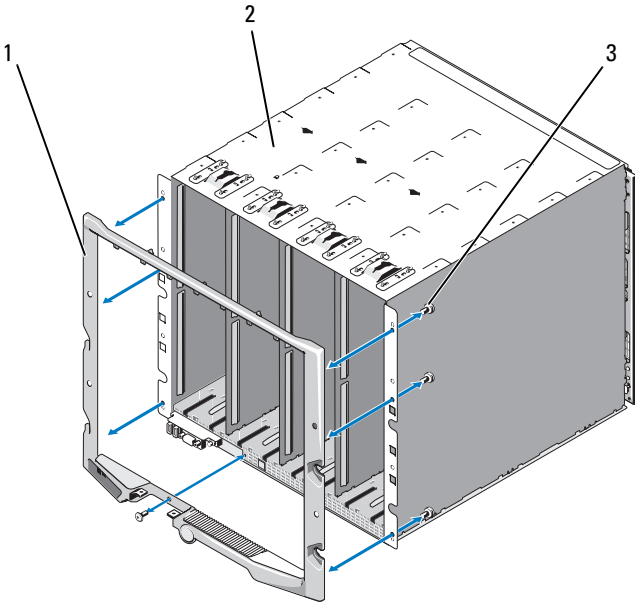
## Enclosure Bezel

### Removing the Enclosure Bezel

- 1 Press the system power switch to turn off the system. See "System Control Panel Features" on page 14.
- 2 Rotate the LCD module so that the underside of the module faces upward. See Figure 4-11.
- 3 Remove the cable cover and disconnect the ribbon cable from the LCD module.
- 4 Remove the eight screws securing the bezel to the enclosure. See Figure 4-7.



**Figure 4-7. Removing and Installing the Bezel**



- |   |            |   |           |
|---|------------|---|-----------|
| 1 | bezel      | 2 | enclosure |
| 3 | screws (8) |   |           |

### **Installing the Enclosure Bezel**

- 1 Attach the bezel to the enclosure using the eight screws. See Figure 4-7.
- 2 Connect the ribbon cable to the LCD module, and reinstall the cover plate.

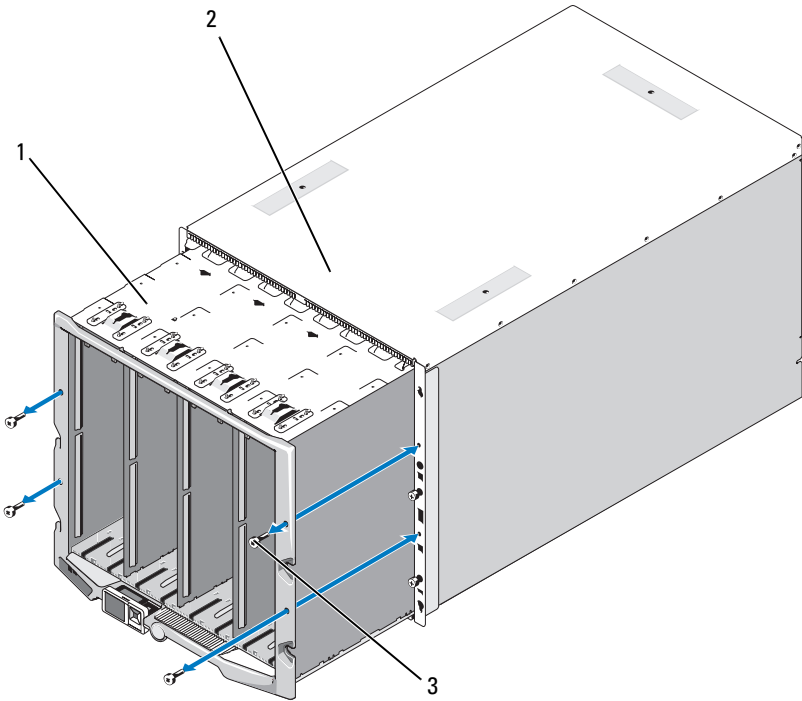
## **Enclosure Midplane (Service Only)**

### **Removing the Front Module Cage Assembly and Midplane**

**⚠ CAUTION:** Only trained service technicians are authorized to remove the system cover and access any of the components inside the system. Before you begin this procedure, review the safety instructions that came with the system.

- ➔ **NOTICE:** A Torx T15 driver is required for this procedure.
- 1 Press the system power switch to turn off the system. See "System Control Panel Features" on page 14.
- ➔ **NOTICE:** To avoid damaging the modules, you must remove all the modules installed in the enclosure before removing the front module cage assembly and midplane.
- ➔ **NOTICE:** If you remove the chassis from the rack, you must remove all modules before moving the chassis. Do not use the LCD display as a handle when moving the chassis.
- 2 Remove all of the blades. See "Removing a Blade" on page 96.
  - 3 Remove the power supply modules. See "Removing a Power Supply Module" on page 159.
  - 4 Remove the fan modules. See "Removing a Fan Module" on page 161.
  - 5 Remove the CMC module(s). See "Removing a CMC Module" on page 162.
  - 6 Remove the iKVM module. See "Removing an iKVM Module" on page 166.
  - 7 Remove the I/O modules. See "Removing an I/O Module" on page 166.
  - 8 Remove the four screws securing the front module cage assembly to the enclosure. See Figure 4-8.

**Figure 4-8. Removing and Installing the Front Module Cage Assembly**

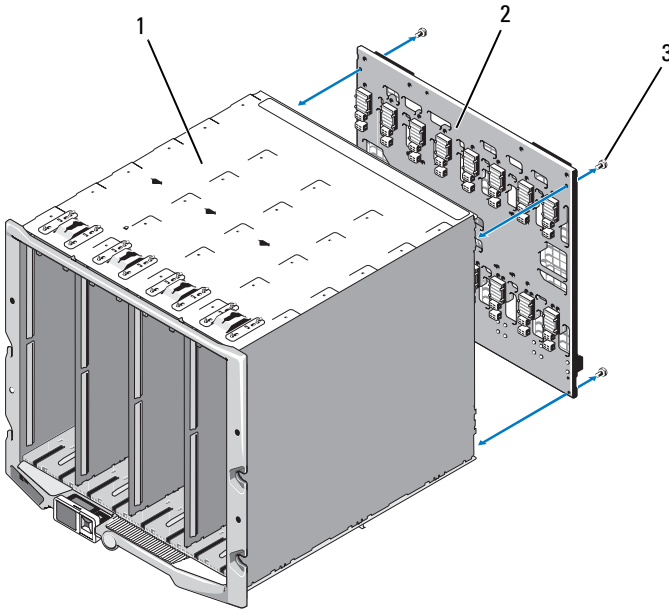


- 1 front module cage assembly
- 2 enclosure
- 3 screws (4)

**NOTICE:** The empty cage assembly weighs 21 kg (47 pounds). Obtain assistance when removing the cage assembly from the enclosure.

- 9 Slide the cage out from the enclosure. See Figure 4-8.
- 10 Disconnect the control-panel cable from the midplane by pressing the small latch at each end of the connector.
- 11 Remove the four T-15 Torx screws securing the midplane to the back of the front cage assembly, and remove the midplane. See Figure 4-9.

**Figure 4-9. Removing and Installing the Midplane**



- 1 front module cage assembly
- 2 midplane
- 3 screws (4)

### **Installing the Midplane and Front Module Cage Assembly**

**⚠ CAUTION:** Only trained service technicians are authorized to remove the system cover and access any of the components inside the system. Before you begin this procedure, review the safety instructions that came with the system.

- 1 Attach the midplane to the front module cage assembly and secure it with the four Torx screws. See Figure 4-8.
- 2 Connect the control-panel cable to the midplane.
- 3 Carefully slide the front module cage assembly into the enclosure. See Figure 4-9.
- 4 Install the four screws to secure the front module cage assembly.
- 5 Install the I/O modules. See "Installing an I/O Module" on page 167.

- 6 Install the iKVM module. See "Installing an iKVM Module" on page 166.
- 7 Install the CMC module. See "Installing a CMC Module" on page 165.
- 8 Install the fan modules. See "Installing a Fan Module" on page 162.
- 9 Install the power supply modules. See "Installing a Power Supply Module" on page 160.
- 10 Install the blades. See "Installing a Blade" on page 98.

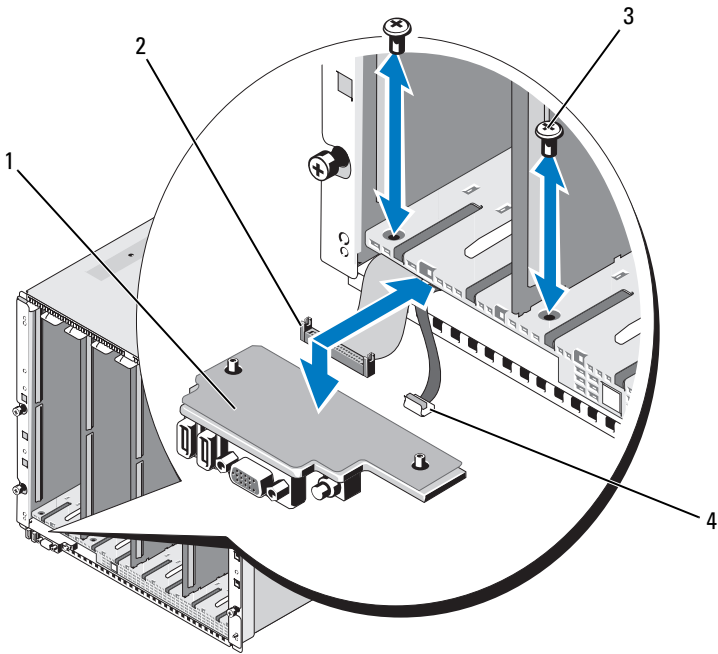
## Enclosure Control Panel Assembly (Service Only)

### Removing the Enclosure Control Panel

 **CAUTION: Only trained service technicians are authorized to remove the system cover and access any of the components inside the system. Before you begin this procedure, review the safety instructions that came with the system.**

- 1 Press the system power switch to turn off the system. See "System Control Panel Features" on page 14.
- 2 Remove the blades. See "Removing a Blade" on page 96.
- 3 Remove the bezel. See "Removing the Enclosure Bezel" on page 168.
- 4 Remove the two screws securing the control panel to the enclosure. See Figure 4-10.

**Figure 4-10. Removing and Installing the Control Panel**



- |   |               |   |                     |
|---|---------------|---|---------------------|
| 1 | control panel | 2 | control-panel cable |
| 3 | screws (2)    | 4 | LCD panel cable     |

- 5 Press the catch at each end of the control-panel cable connector, and remove the control-panel cable from the underside of the control panel.
- 6 Use the pull-tab to disconnect the LCD panel cable from the underside of the control panel.

### Installing the Enclosure Control Panel

**⚠ CAUTION: Only trained service technicians are authorized to remove the system cover and access any of the components inside the system. Before you begin this procedure, review the safety instructions that came with the system.**

- 1 Connect the LCD panel cable to the new control panel.
- 2 Connect the control panel cable to the underside of the new control panel.

- 3 Reinstall the control panel using the two screws.
- 4 Reinstall the bezel. See "Installing the Enclosure Bezel" on page 169.
- 5 Install the blades. See "Installing a Blade" on page 98.

## LCD Module

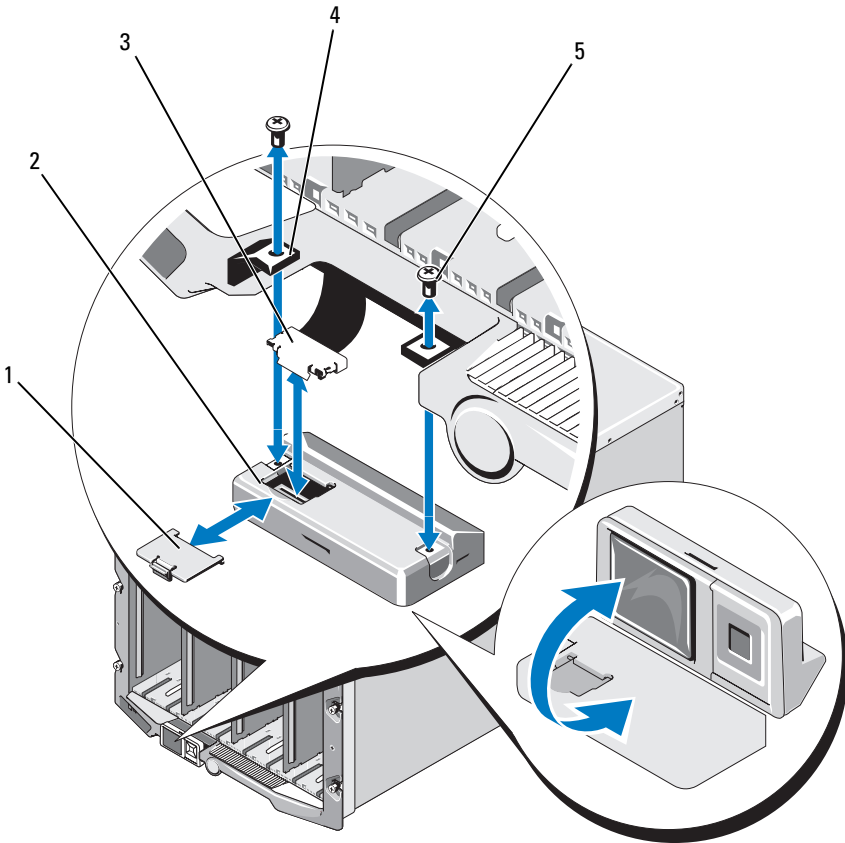
### Removing the LCD Module



**CAUTION: Only trained service technicians are authorized to remove the system cover and access any of the components inside the system. Before you begin this procedure, review the safety instructions that came with the system.**

- 1 Rotate the LCD module so that the underside of the module faces upward. See Figure 4-11.

**Figure 4-11. Removing and Installing the LCD Module**



- |   |              |   |            |
|---|--------------|---|------------|
| 1 | cable cover  | 2 | LCD module |
| 3 | ribbon cable | 4 | hinges (2) |
| 5 | screws (2)   |   |            |

- 2 Remove the cable cover.
- 3 Disconnect the ribbon cable.
- 4 Remove the two screws securing the LCD module to the hinges.



## Installing the LCD Module



**CAUTION: Only trained service technicians are authorized to remove the system cover and access any of the components inside the system. Before you begin this procedure, review the safety instructions that came with the system.**

- 1 Attach the new LCD module to the hinges using the two screws. See Figure 4-11.
- 2 Connect the ribbon cable to the module, and reinstall the cover plate.



# Troubleshooting Your System

## Safety First—For You and Your System

To perform certain procedures in this document, you must remove the system cover and work inside the system. While working inside the system, do not attempt to service the system except as explained in this guide and elsewhere in your system documentation.



**CAUTION:** Many repairs may only be done by a certified service technician. You should only perform troubleshooting and simple repairs as authorized in your product documentation, or as directed by the online or telephone service and support team. Damage due to servicing that is not authorized by Dell is not covered by your warranty. Read and follow the safety instructions that came with the product.

## Start-Up Routine

Look and listen during the system's start-up routine for the indications described in Table 5-1.

**Table 5-1. Start-Up Routine Indicators**

Look/listen for:	Action
An error message displayed on the monitor	See "System Messages" on page 66.
Alert messages from the systems management software	See the systems management software documentation.
The monitor's power indicator	See "Troubleshooting Video" on page 180.
The keyboard indicators	See "Troubleshooting the Keyboard" on page 181.
The USB diskette drive activity indicator	See "Troubleshooting USB Devices" on page 183.
The USB optical drive activity indicator	See "Troubleshooting USB Devices" on page 183.
The hard-drive activity indicator	See "Troubleshooting Hard Drives" on page 192.

## Checking the Equipment

This section provides troubleshooting procedures for external devices attached to the system, such as the monitor, keyboard, or mouse. Before you perform any of the procedures, see "Troubleshooting External Connections" on page 180.

## Troubleshooting External Connections

Loose or improperly connected cables are the most likely source of problems for the system, monitor, and other peripherals (such as a keyboard, mouse, or other external device). Ensure that all external cables are securely attached to the external connectors on your system. See Figure 1-6 for the front-panel connectors on your system and Figure 1-9 for the back-panel connectors.

### Troubleshooting Video

#### *Problem*

- Loss of video, or poor video quality

#### *Possible Cause*

- Faulty monitor or monitor cable
- Video port disabled
- Faulty iKVM module
- Blade connection to midplane

#### *Action*

- 1 Check the connection to the iKVM module.  
Try swapping cables if another monitor cable is available.
- 2 Verify that the iKVM firmware revision is current.
- 3 Check the monitor connection to either the front-panel connector on the blade or the back-panel iKVM module.
- 4 Ensure that the port is not disabled by the CMC or by redirection to another port.

- 5 If two or more blades are installed in the enclosure, select a different blade.  
If the monitor is connected to the back-panel iKVM module and works with another blade, the first blade may need to be reseated. See "Removing and Installing a Blade" on page 96. If reseating the blade does not help, the blade may be faulty. See "Getting Help" on page 217.
- 6 Swap the monitor with a known-working monitor.  
If the monitor does not work when connected to the blade front-panel connector, the blade may be faulty. See "Getting Help" on page 217.  
If the monitor does not work when connected to the iKVM module, the iKVM module may be faulty. See "Getting Help" on page 217.

## **Troubleshooting the Keyboard**

### ***Problem***

- No keyboard input

### ***Possible Cause***

- Faulty keyboard or keyboard cable
- iKVM module
- Blade connection to midplane
- Faulty SIP (KVM dongle, used with an external KVM)

### ***Action***

- 1 Ensure that the blade(s) is turned on.
- 2 Verify that the iKVM firmware revision is current.
- 3 Check the keyboard connection to either the front-panel connector on the blade or to the back-panel iKVM module.
- 4 If the keyboard is connected to an external KVM using a SIP, check that the SIP is compatible with the KVM.
- 5 If two or more blades are installed in the enclosure, select a different blade.  
If the keyboard is connected to the back-panel iKVM module and works with another blade, the first blade may need to be reseated. See "Removing

and Installing a Blade" on page 96. If reseating the blade does not help, the blade may be faulty. See "Getting Help" on page 217.

- 6 Swap the keyboard with a known-working keyboard and repeat step 3 and step 5. If the keyboard does not work with any blade, see "Getting Help" on page 217.

## **Troubleshooting the Mouse**

### ***Problem***

No mouse input

### ***Problem***

- Mouse or mouse cable
- Blade
- SIP (KVM dongle, used with an external KVM)

### ***Action***

- 1 Ensure that the blade(s) is turned on.
- 2 Verify that the iKVM firmware revision is current.
- 3 Check the mouse connection to the either the front-panel connector on the blade or to the back-panel iKVM module.
- 4 If the keyboard is connected to an external KVM using a SIP, check that the SIP is compatible with the KVM.
- 5 If two or more blades are installed in the enclosure, select a different blade.  
If the mouse is connected to the back-panel iKVM module and works with another blade, the first blade may need to be reseated. See "Removing and Installing a Blade" on page 96. If reseating the blade does not help, the blade may be faulty. See "Getting Help" on page 217.
- 6 Swap the mouse with a known-working mouse and repeat step 3 and step 5. If the mouse does not work with any blade, see "Getting Help" on page 217.

## Troubleshooting USB Devices



**NOTE:** USB devices can be connected only to the blade front panel. Total length of a USB cable should not exceed 3 m (9.8 ft).

### ***Problem***

- USB device or USB device cable
- Multiple devices connected directly to blade (powered USB hub not used)
- Blade

### ***Action***

- 1 Ensure that the blade(s) is turned on.
- 2 Check the USB device connection to the blade.
- 3 Swap the USB device with a known-working USB device.
- 4 Connect the USB devices to the blade using a powered USB hub.
- 5 If another blade is installed, connect the USB device to that blade. If the USB device works with a different blade, the first blade may be faulty. See "Getting Help" on page 217.

## Responding to a Systems Management Alert Message

The CMC management applications monitor critical system voltages and temperatures, and the cooling fans in the system. For information about the CMC alert messages, see the *Configuration Guide*.

## Troubleshooting a Wet Enclosure

### ***Problem***

- Liquid spills
- Splashes
- Excessive humidity

### **Action**



**CAUTION: Many repairs may only be done by a certified service technician. You should only perform troubleshooting and simple repairs as authorized in your product documentation, or as directed by the online or telephone service and support team. Damage due to servicing that is not authorized by Dell is not covered by your warranty. Read and follow the safety instructions that came with the product.**

- 1 Turn off the system.
- 2 Disconnect the power supplies from the PDU.



**CAUTION: Wait until all of the indicators on the power supplies turn off before proceeding.**

- 3 Remove all the blades. See "Removing a Blade" on page 96.
- 4 Remove the CMC module. See "Removing a CMC Module" on page 162.
- 5 Remove the iKVM module. See "Removing an iKVM Module" on page 166.
- 6 Remove all I/O modules installed in the system. See "Removing an I/O Module" on page 166.
- 7 Remove all the fan modules. See "Removing a Fan Module" on page 161.
- 8 Remove all the power supply modules. See "Removing a Power Supply Module" on page 159.
- 9 Let the system dry thoroughly for at least 24 hours.
- 10 Install all the power supply modules. See "Installing a Power Supply Module" on page 160.
- 11 Install all the fan modules. See "Installing a Fan Module" on page 162.
- 12 Install all the I/O modules. See "Installing an I/O Module" on page 167.
- 13 Install the CMC module(s). See "Installing a CMC Module" on page 165.
- 14 Install the iKVM module. See "Installing an iKVM Module" on page 166.
- 15 Install all the blades. See "Installing a Blade" on page 98.
- 16 Reconnect the power supply modules to their PDU and start up the system.

If the system does not start up properly, see "Getting Help" on page 217.



- 17** Run the Server Administrator diagnostics to confirm that the system is working properly (see "Running System Diagnostics" on page 197).  
If the tests fail, see "Getting Help" on page 217.

## Troubleshooting a Damaged Enclosure

### *Problem*

- System was dropped or damaged

### *Action*

- 1** Ensure that the following components are properly installed and connected:
  - CMC module
  - iKVM module
  - I/O modules
  - Power supply modules
  - Fan modules
  - Blades
- 2** Ensure that all cables are properly connected.
- 3** Ensure that all components are properly installed and free from damage.
- 4** Run the online diagnostics. See "Running System Diagnostics" on page 197.  
If the tests fail, see "Getting Help" on page 217.

## Troubleshooting Enclosure Components

The following procedures describe how to troubleshoot the following components:

- Power supply modules
- Fan modules
- CMC module
- Network switch module

## Troubleshooting Power Supply Modules

### *Problem*

- A power supply module is not operating properly


### *Action*



**NOTICE:** The power-supply modules are hot-pluggable. Remove and replace only one power-supply module at a time in a system that is turned on. Leave a failed power-supply module installed in the enclosure until you are ready to replace it. Operating the system with a power-supply module removed for extended periods of time can cause the system to overheat.



**NOTE:** The 2360-W power supply modules require a 200–240 V power source to operate. If they are plugged into 110-V electrical outlets, the power supply modules do not power up.

- 1 Locate the faulty power supply module and check the indicators. See Figure 1-11. The power supply's AC indicator is green if AC power is available. The power supply's fault indicator is amber if the power supply is faulty. If no indicators are lit, ensure that 208V AC power is available from the PDU and that the power cable is properly connected to the power supply module.
- 2 Install a new power supply. See "Installing a Power Supply Module" on page 160.
  -  **NOTE:** After installing a new power supply, allow several seconds for the system to recognize the power supply and determine whether it is working properly. The power supply DC power indicator turns green if the power supply is functioning properly. See Figure 1-11.
- 3 If none of the power supplies show a fault LED and the blades will not power on, check the LCD display or CMC for status messages.
- 4 If the problem is not resolved, see "Getting Help" on page 217 for information about obtaining technical assistance.

## Troubleshooting Fan Modules

### *Problem*

- A fan is not operating properly

### **Action**



**NOTICE:** The fan modules are hot-pluggable. Remove and replace only one fan module at a time in a system that is turned on. Operating the system without all six fan modules for extended periods of time can cause the system to overheat.

- 1 Locate the faulty fan.  
Each fan module has indicators that identify a faulty fan. See Figure 1-12.
- 2 Remove the fan module. See "Removing a Fan Module" on page 161.
- 3 Examine the blades for debris. If debris is present, carefully remove it.
- 4 Reseat the faulty fan. See "Installing a Fan Module" on page 162.
- 5 If none of the fans show a fault LED and the blades will not power on, check the LCD display or CMC for status messages.
- 6 If the problem is not resolved, install a new fan.
- 7 If the new fan does not operate, see "Getting Help" on page 217.

## **Troubleshooting the CMC Module**

### **Problem**


- CMC module is not operating properly
- System message indicates a problem with the CMC module
- CMC module does not failover or fail back
- CMC module cable connections

### **Action**



**NOTE:** To eliminate the possibility of a hardware problem with the module or its attaching devices, first ensure that the module is properly initialized and configured. See the *Configuration Guide* and the documentation that came with the module before performing the following procedure.

- 1 Verify that the latest firmware is installed on the CMC module.  
See [support.dell.com](http://support.dell.com) for the latest firmware and refer to the release notes for firmware compatibility and update information.
- 2 Verify that the CMC(s) have valid IP addresses for the subnet. Verify using the ICMP ping command.

- 3 Reseat the CMC module and see if the CMC module fault indicator turns off. See "CMC Module" on page 162. See Figure 1-14 for more information about the module's indicators.
- 4 If another CMC module is available, swap the two modules.
- 5 If the fault indicator is off, but the serial device connected to the serial port is not properly operating, go to step 6. If the fault indicator is off, but the network management device connected to the network interface connector port is not properly operating, go to step 9.
- 6 Reseat the serial cable to the serial connector on the CMC module and to the serial device communicating with it.
- 7 Connect a known-working null-modem serial cable between the CMC module and the serial device.
- 8 Connect a known-working serial device to the CMC module.  
If the serial device and CMC module still do not communicate with each other, see "Getting Help" on page 217.
- 9 Reseat the network cable to the network connector on the CMC module and to the network device.
- 10 Connect a known-working network cable between the CMC module and the network device.  
 **NOTE:** If the CMC is connected to another CMC in an adjacent enclosure and there is no failover, check the network cable connected to port Gb2. If there is no external management connection to the CMC, check the cable connected to port Gb1. See Figure 1-14.
- 11 Connect a known-working network device to the CMC module.  
If the network device and CMC module still do not communicate with each other, see "Getting Help" on page 217.

## Troubleshooting the iKVM Module

### ***Problem:***

When using iDRAC video\console redirection you cannot see video through the iKVM when you switch to a blade running Linux.

***Likely Cause and Solution:***

A monitor or KVM appliance with a lower resolution has recently been added.

***Example:***

A blade running X Windows under Linux is inserted and powered on. A user connects to the blade in OS GUI mode via the iDRAC and a video resolution is detected and hard-set for that session. A monitor or KVM appliance is attached to the front or rear iKVM interface on the M1000e enclosure. The monitor or the KVM appliance is configured with a resolution LOWER than the currently configured resolution in the X-Window session on the Linux blade.

When you select the Linux blade using the front or rear port on the iKVM, the iDRAC circuit adopts the lower resolution of the external connected devices. The video on the lower resolution monitor or the KVM appliance will not be displayed until X Windows is restarted (iDRAC video should still be viewable.)

***Solution:***

- 1** From the iDRAC session, exit and re-enter GUI mode. The lower resolution will be communicated and utilized.
- 2** Set all monitors or KVM appliances connected to the M1000e enclosure to the same resolution or higher as configured on the Linux blades in GUI mode.
- 3** From the lower resolution monitor (no video displayed) press <CTRL> <ALT> <F3> to change to the non-GUI login screen.
- 4** Restart X Windows to detect and utilize the lower resolution.

## **Troubleshooting a Network Switch Module**

***Problem***

- System cannot communicate with the network
- Network cable connections
- Network switch module and hub configuration settings

## Action



**NOTE:** To eliminate the possibility of a hardware problem with the module or its attaching devices, first ensure that the module is properly initialized and configured. See the *Configuration Guide* and the documentation that came with the module before performing the following procedure.

- 1 Check that you have installed the module in an I/O slot that matches its fabric type. See "Supported I/O Module Configurations" on page 44.
- 2 Check that the passthrough module or switch ports are cabled correctly.  
A given mezzanine card in a full-height blade connects to two I/O ports on the two associated I/O modules. See "I/O Module Port Assignments - Full-Height Blades" on page 47.
- 3 Verify that the proper firmware revision is properly initialized and configured.
- 4 Verify that the switch module has a valid IP address for the subnet. Verify using the ICMP ping command.
- 5 Check the network connector indicators on the network switch module.
  - If the link indicator displays an error condition, check all cable connections.  
See "I/O Connectivity" on page 42 for the link indicator error conditions for your particular network switch module.
  - Try another connector on the external switch or hub.
  - If the activity indicator does not light, replace the network switch module. See "I/O Modules" on page 166.
- 6 Using the switch management interface, verify the switch port properties. If the switch is configured correctly, back up the switch configuration and replace the switch. See the switch module documentation for details.
- 7 If the blade requires a mezzanine card for a particular network switch module, ensure that the appropriate mezzanine card is installed. If so, reseal the mezzanine card. See "I/O Module Mezzanine Cards" on page 123.

If the network link indicator on the blade is green, then the blade has a valid link to the appropriate network switch module.

- 8 Ensure that the appropriate operating system drivers are installed and that the protocol settings are configured to ensure proper communication.

## Troubleshooting Blade Components

The following procedures describe how to troubleshoot the following components. See Figure 3-4 for the location of the components inside the blade.

- Memory
- Hard drives
- Microprocessors
- Blade system board
- Battery

### Troubleshooting Blade Memory

#### *Problem*

- Faulty memory module
- Faulty blade board

#### *Action*




**CAUTION:** Many repairs may only be done by a certified service technician. You should only perform troubleshooting and simple repairs as authorized in your product documentation, or as directed by the online or telephone service and support team. Damage due to servicing that is not authorized by Dell is not covered by your warranty. Read and follow the safety instructions that came with the product.



**NOTE:** Before performing the following procedure, ensure that you have installed the memory modules according to the memory installation guidelines for the blade. See "System Memory" on page 105.

- 1 Restart the blade.
  - a Press the power button once to turn off the blade.
  - b Press the power button again to apply power to the blade.If no error messages appear, go to step 8.


- 2 Enter the System Setup program and check the system memory setting. See "Using the System Setup Program" on page 79.  
If the amount of memory installed matches the system memory setting, go to step 8.
  - 3 Remove the blade. See "Removing a Blade" on page 96.
  - 4 Open the blade. See "Opening the Blade" on page 100.
-  **CAUTION: The memory modules are hot to the touch for some time after the blade has been powered down. Allow time for the memory modules to cool before handling them. Handle the memory modules by the card edges and avoid touching the components.**
- 5 Reseat the memory modules in their sockets. See "Installing Memory Modules" on page 120.
  - 6 Close the blade. See "Closing the Blade" on page 104.
  - 7 Install the blade. See "Installing a Blade" on page 98.
  - 8 Run the system memory test in the system diagnostics. See "Running System Diagnostics" on page 197.  
If the test fails, see "Getting Help" on page 217.

## Troubleshooting Hard Drives


### *Problem*

- Device driver error
- Improperly seated hard drive carrier
- Faulty hard drive or hard-drive carrier
- Device drivers

### *Action*

-  **CAUTION: Many repairs may only be done by a certified service technician. You should only perform troubleshooting and simple repairs as authorized in your product documentation, or as directed by the online or telephone service and support team. Damage due to servicing that is not authorized by Dell is not covered by your warranty. Read and follow the safety instructions that came with the product.**




 **NOTICE:** This troubleshooting procedure can destroy data stored on the hard drive. Before you proceed, back up all the files on the hard drive, if possible. Refer to the RAID controller documentation for rebuilding and servicing a RAID array.

- 1 Run the appropriate controllers test and the hard drive tests in system diagnostics. See "Running System Diagnostics" on page 197.

If the tests fail, continue to step 3.

- 2 Take the hard drive offline and wait until the hard-drive indicator codes on the drive carrier signal that the drive may be removed safely, then remove and reseat the drive carrier in the blade. See "Hard Drives" on page 142.
- 3 Restart the blade, enter the System Setup program, and confirm that the drive controller is enabled. See "Integrated Devices Screen" on page 85.
- 4 Ensure that any required device drivers are installed and are configured correctly.

 **NOTICE:** Installing a hard drive into another bay will break the mirror if the mirror state is optimal.

- 5 Remove the hard drive and install it in the other drive bay. See "Hard Drives" on page 142.
- 6 If the problem is resolved, reinstall the hard drive in the original bay. If the hard drive functions properly in the original bay, the drive carrier could have intermittent problems. Replace the drive carrier.
- 7 If the hard drive is the boot drive, ensure that the drive is configured and connected properly. See "Configuring the Boot Drive" on page 144.
- 8 Partition and logically format the hard drive.
- 9 If possible, restore the files to the drive. If the problem persists, see "Getting Help" on page 217.

## Troubleshooting Microprocessors

### *Problem*

- System message indicates a problem with the microprocessor or hypertransport (HT) bridge cards
- Heat sink is not installed for the microprocessor

- (PowerEdge M805 systems only) – Missing or incorrectly installed HT cards in sockets CPU3 and CPU4.

### **Action**



**CAUTION: Many repairs may only be done by a certified service technician. You should only perform troubleshooting and simple repairs as authorized in your product documentation, or as directed by the online or telephone service and support team. Damage due to servicing that is not authorized by Dell is not covered by your warranty. Read and follow the safety instructions that came with the product.**

- 1 Remove the blade. See "Removing a Blade" on page 96.
- 2 Open the blade. See "Opening the Blade" on page 100.



**CAUTION: The processor and heat sink can become extremely hot. Be sure the processor has had sufficient time to cool before handling.**

- 3 Ensure that the microprocessor(s) and heat sink(s) are properly installed. See "Processors" on page 128.
- 4 *If your system only has one microprocessor installed*, ensure that it is installed in the primary processor socket. See Figure 7-3 or Figure 7-4.
- 5 *For a PowerEdge M805 system*, check that hypertransport (HT) bridge cards are installed in sockets CPU3 and CPU4, and that both cards are fully seated in the processor sockets. See "HT Bridge Card (Service Only)" on page 138.
- 6 Close the blade. See "Closing the Blade" on page 104.
- 7 Install the blade. See "Installing a Blade" on page 98.
- 8 Run **Quick Tests** in the system diagnostics. See "Running System Diagnostics" on page 197.  
If the tests fail or the problem persists, see "Getting Help" on page 217.

## **Troubleshooting the Blade Board**

### **Problem**

- System message indicates a problem with the blade board.

### **Action**



**CAUTION: Only trained service technicians are authorized to remove the system cover and access any of the components inside the system. Before you begin this procedure, review the safety instructions that came with the system.**

- 1 Turn off the blade.
- 2 Clear the blade NVRAM.  
See "Blade System Board Jumper Settings" on page 203 for the location of the NVRAM\_CLR jumper.
- 3 If there is a still a problem with the blade, remove and reinstall the blade.  
See "Installing a Blade" on page 98.
- 4 Turn on the blade.
- 5 Run the system board test in the system diagnostics. See "Running System Diagnostics" on page 197.  
If the tests fail, see "Getting Help" on page 217.

## **Troubleshooting the NVRAM Backup Battery**

### **Problem**

- System message indicates a problem with the battery
- System Setup program loses system configuration information
- System date and time do not stay current

Each blade contains a battery which maintains the blade configuration, date, and time information in NVRAM when you turn off the blade. You may need to replace the battery if an incorrect time or date is displayed during the boot routine.

You can operate the blade without a battery; however, the blade configuration information maintained by the battery in NVRAM is erased each time you remove power from the blade. Therefore, you must re-enter the system configuration information and reset the options each time the blade boots until you replace the battery.

## Action



**CAUTION:** Many repairs may only be done by a certified service technician. You should only perform troubleshooting and simple repairs as authorized in your product documentation, or as directed by the online or telephone service and support team. Damage due to servicing that is not authorized by Dell is not covered by your warranty. Read and follow the safety instructions that came with the product.

- 1 Re-enter the time and date through the System Setup program. See "Using the System Setup Program" on page 79.
- 2 Remove the blade for at least one hour. See "Removing a Blade" on page 96.
- 3 Install the blade. See "Installing a Blade" on page 98.
- 4 Enter the System Setup program.

If the date and time are not correct in the System Setup program, replace the battery. See "Blade System Board NVRAM Backup Battery" on page 140.

If the problem is not resolved by replacing the battery, see "Getting Help" on page 217.



**NOTICE:** If the blade is turned off for long periods of time (for weeks or months), the NVRAM may lose its system configuration information. This situation is caused by a defective battery.



**NOTE:** Some software may cause the blade's time to speed up or slow down. If the blade seems to operate normally except for the time kept in the System Setup program, the problem may be caused by software rather than by a defective battery.

# Running System Diagnostics

If you experience a problem with your blade, run the diagnostics before calling for technical assistance. The purpose of the diagnostics is to test your blade's hardware without requiring additional equipment or risking data loss. If you are unable to fix the problem yourself, service and support personnel can use diagnostics test results to help you solve the problem.

## Using Server Administrator Diagnostics

To assess a blade problem, first use the online Server Administrator diagnostics. If you are unable to identify the problem, then use the system diagnostics.

To access the online diagnostics, log into the Server Administrator home page, and then click the **Diagnostics** tab. For information about using diagnostics, see the online help. For additional information, see the *Server Administrator User's Guide*.

## System Diagnostics Features

The system diagnostics provides a series of menus and options for particular device groups or devices on a blade. The system diagnostics menus and options allow you to:

- Run tests individually or collectively
- Control the sequence of tests
- Repeat tests
- Display, print, or save test results
- Temporarily suspend testing if an error is detected or terminate testing when a user-defined error limit is reached
- View help messages that briefly describe each test and its parameters
- View status messages that inform you if tests are completed successfully
- View error messages that inform you of problems encountered during testing

# When to Use the System Diagnostics

If a major component or device in the blade does not operate properly, component failure may be indicated. As long as the microprocessor and the blade's input/output devices (monitor, keyboard, and diskette drive) are functioning, you can use the system diagnostics to help identify the problem.

## Running the System Diagnostics

The system diagnostics can be run from either the utility partition on your hard drive or a USB flash drive.



**NOTICE:** Use the system diagnostics to test only your blade. Using this program with other blades may cause invalid results or error messages. In addition, use only the program that came with your blade (or an updated version of that program).

### From the Utility Partition

- 1 As the blade boots, press <F10> during POST.
- 2 From the utility partition main menu under **Run System Utilities**, select **Run System Diagnostics**.




**NOTE:** If the utility partition has been removed from the drive, download the Dell PowerEdge Diagnostics from [support.dell.com](http://support.dell.com) and install the diagnostics to a USB flash drive, as described in the following section.

### From a USB Flash Drive

- 1 Format the USB flash drive to emulate a hard drive.  
See the documentation that came with your USB flash drive for instructions.
- 2 Configure the USB flash drive to be a bootable device.  
See the documentation that came with your USB flash drive for instructions. Dell also provides a USB memory key boot utility for download at [support.dell.com](http://support.dell.com).
- 3 Install DKMS DOS on the USB flash drive.
- 4 Create a directory for the system diagnostics on the USB flash drive.
- 5 Copy the system diagnostics files into the directory.

- 6 Ensure that you have the USB flash drive connected to the blade.
- 7 Enter the System Setup program and ensure that the **USB Flash Drive Emulation Type** option is set to **Auto** and set the USB flash drive as the first device in the **Hard-Disk Drive Sequence** option.


See "Using the System Setup Program" on page 79 for instructions.

 **NOTE:** If you power up or reboot the blade without the USB flash drive connected to the blade, you must reset the options in the System Setup program again.

- 8 Ensure that you have the USB flash drive connected to the blade.
- 9 Reboot the blade.

If the blade fails to boot, see "Getting Help" on page 217.

When you start the system diagnostics, a message is displayed stating that the diagnostics are initializing. Next, the **Diagnostics** menu appears. The menu allows you to run all or specific diagnostics tests or to exit the system diagnostics.

 **NOTE:** Before you read the rest of this section, start the system diagnostics so that you can see the utility on your screen.

## System Diagnostics Testing Options

To select an option from the **Diagnostics** menu, highlight the option and press <Enter>, or press the key that corresponds to the highlighted letter in the option.

Table 6-1 provides a brief explanation of testing options.

**Table 6-1. System Diagnostics Testing Options**

Testing Option	Function
Quick Tests	Performs a quick check of the blade. Select <b>Test All Devices</b> and then select <b>Quick Tests</b> . This option runs device tests that do not require user interaction. Use this option to quickly identify the source of your problem.
Test One Device	Tests a particular device.
Extended Tests	Performs a more thorough check of the blade. Select <b>Test All Devices</b> and then select <b>Extended Tests</b> .

**Table 6-1. System Diagnostics Testing Options (continued)**

Testing Option	Function
Advanced Testing	Checks a particular area of the blade.
Information and Results	Displays test results.
Program Options	Sets various test parameters.
Device Configuration	Displays an overview of the devices in the blade.
Exit to MS-DOS	Exits the diagnostics and returns to the <b>System Utilities</b> menu.

## Using the Advanced Testing Options

When you select **Advanced Testing** from the **Diagnostics** menu, the main screen of the diagnostics appears and displays the following information:

- Two lines at the top of the screen identify the diagnostics utility, the version number, and the system's service tag number.
- The left side of the screen under **Device Groups** lists the diagnostic device groups in the order that they are tested if you select **All** under the **Run Tests** submenu. Press the up- or down-arrow keys to highlight a particular device group. Press the left- or right-arrow keys to select the options on the menu. As you move from one menu option to another, a brief explanation of the highlighted option appears at the bottom of the screen.
- The right side of the screen under **Devices for Highlighted Group** lists the specific devices within a particular test group.
- The menu area consists of two lines at the bottom of the screen. The first line lists the menu options that you can select; press the left- or right-arrow key to highlight an option. The second line provides information about the highlighted option.

For more information about a device group or device, highlight the **Help** option and press <Enter>. Press <Esc> to return to the previous screen.



## **Error Messages**

When you run a system diagnostics test, you may receive an error message during testing. Record the message on a copy of the Diagnostics Checklist. For a copy of the Diagnostics Checklist and instructions for obtaining technical assistance, see "Getting Help" on page 217.



# System Board Information

## Blade System Board Jumper Settings





**⚠ CAUTION:** Many repairs may only be done by a certified service technician. You should only perform troubleshooting and simple repairs as authorized in your product documentation, or as directed by the online or telephone service and support team. Damage due to servicing that is not authorized by Dell is not covered by your warranty. Read and follow the safety instructions that came with the product.

### PowerEdge M905 Jumper Settings

Figure 7-1 shows the location of the configuration jumpers on the blade system board. Table 7-1 lists the jumper settings.


**✏ NOTE:** Figure 7-1 is oriented with the front end of the blade system board facing to the right.

**Table 7-1. PowerEdge M905 Jumper Settings**





PSWD_EN		(default)	The password feature is enabled.
			The password feature is disabled.
NVRAM_CLR		(default)	The configuration settings are retained at system boot.
			The configuration settings are cleared at the next system boot. (If the configuration settings become corrupted to the point where the system will not boot, install the jumper and boot the system. Remove the jumper before restoring the configuration information.)

## PowerEdge M805 Jumper Settings

Figure 7-2 shows the location of the configuration jumpers on the blade system board. Table 7-2 lists the jumper settings.


 **NOTE:** Figure 7-2 is oriented with the front end of the blade system board facing to the right.

**Table 7-2. PowerEdge M805 Jumper Settings**

PSWD_EN		(default)	The password feature is enabled.
			The password feature is disabled.
NVRAM_CLR		(default)	The configuration settings are retained at system boot.
			The configuration settings are cleared at the next system boot. (If the configuration settings become corrupted to the point where the system will not boot, install the jumper and boot the system. Remove the jumper before restoring the configuration information.)





## PowerEdge M600 Jumper Settings

Figure 7-3 shows the location of the configuration jumpers on the blade system board. Table 7-3 lists the jumper settings.

 **NOTE:** Figure 7-3 is oriented with the front end of the blade system board facing to the right.

**Table 7-3. PowerEdge M600 Jumper Settings**


---

PWRD_EN		(default)	The password feature is enabled.
			The password feature is disabled.
NVRAM_CLR		(default)	The configuration settings are retained at system boot.
			The configuration settings are cleared at the next system boot. (If the configuration settings become corrupted to the point where the system will not boot, install the jumper and boot the system. Remove the jumper before restoring the configuration information.)

---





## PowerEdge M605 Jumper Settings

Figure 7-4 shows the location of the configuration jumpers on the blade system board. Table 7-4 lists the jumper settings.

 **NOTE:** Figure 7-4 is oriented with the front end of the blade system board facing to the right.

**Table 7-4. PowerEdge M605 Jumper Settings**

---

PSWD_EN		(default)	The password feature is enabled.
			The password feature is disabled.
<hr/>			
NVRAM_CLR		(default)	The configuration settings are retained at system boot.
			The configuration settings are cleared at the next system boot. (If the configuration settings become corrupted to the point where the system will not boot, install the jumper and boot the system. Remove the jumper before restoring the configuration information.)

---

# System Board Connectors

## PowerEdge M905 System Board

Figure 7-1. PowerEdge M905 System Board Connectors

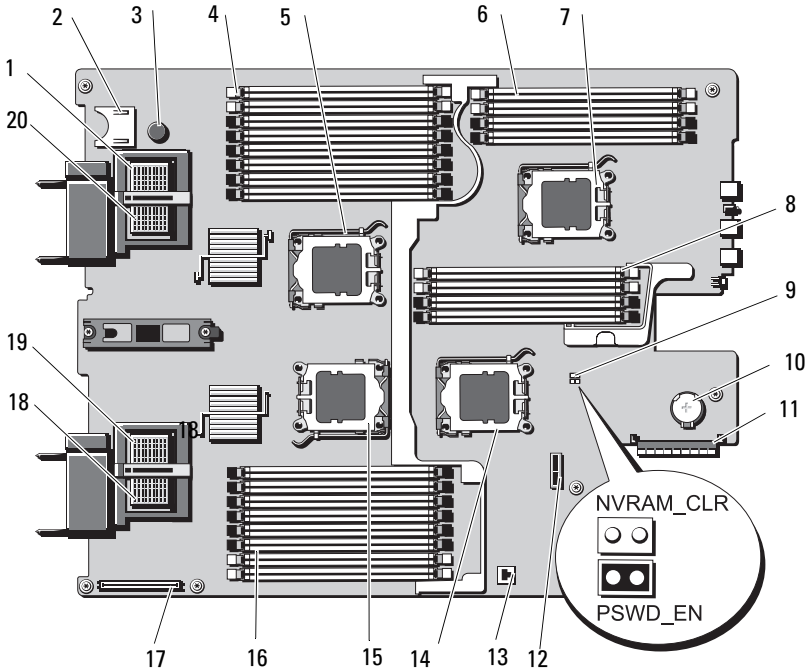


Table 7-5. PowerEdge M905 System Board Connectors

Connector	Description
1 MEZZ4_FAB_B	Mezzanine card connector 4 Fabric B
2	SD card connector
3	system board retention pin
4 B1 – B8	memory modules B1 – B8
5 CPU2	Processor 2 socket

**Table 7-5. PowerEdge M905 System Board Connectors (continued)**

Connector	Description
6 D1 – D4	memory modules D1 – D4
7 CPU4	Processor 4 socket
8 C1 – C4	memory modules C1 – C4
9 PSWD_EN, NVRAM_CLR	system configuration jumpers <b>NOTE:</b> Access requires removal of system board. See "Removing the System Board" on page 150.
10	connector for the 3.0-V coin battery <b>NOTE:</b> Access requires removal of system board. See "Removing the System Board" on page 150.
11 J_STORAGE	Storage controller card connector
12	Hard-drive backplane connector
13	Hardware key socket for integrated NIC TOE/iSCSI feature
14 CPU3	Processor 3 socket
15 CPU1	Processor 1 socket
16 A1 – A8	memory modules A1 – A8
17	video controller card connector
18 MEZZ1_FAB_C	Mezzanine card connector 1 Fabric C
19 MEZZ2_FAB_B	Mezzanine card connector 2 Fabric B
20 MEZZ3_FAB_C	Mezzanine card connector 3 Fabric C

**NOTE:** For the full name of an abbreviation or acronym used in this table, see the "Glossary" on page 219.



# PowerEdge M805 System Board

Figure 7-2. PowerEdge M805 System Board Connectors

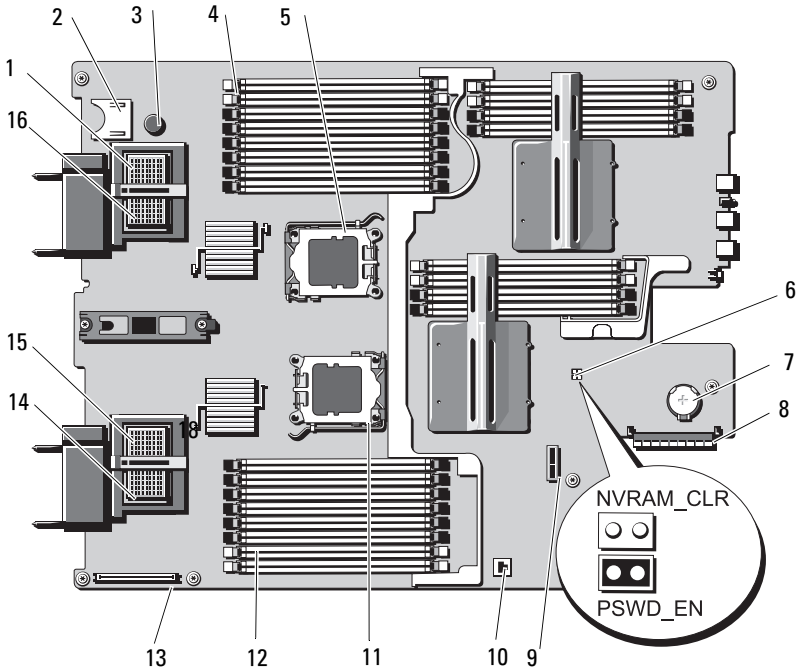


Table 7-6. PowerEdge M805 System Board Connectors

Connector	Description
1	MEZZ4_FAB_B Mezzanine card connector 4 Fabric B
2	SD card connector
3	system board retention pin
4	B1 – B8 memory modules B1 – B8
5	CPU2 Processor 2 socket
6	PSWD_EN, NVRAM_CLR system configuration jumpers
	<b>NOTE:</b> Access requires removal of system board. See "Removing the System Board" on page 150.

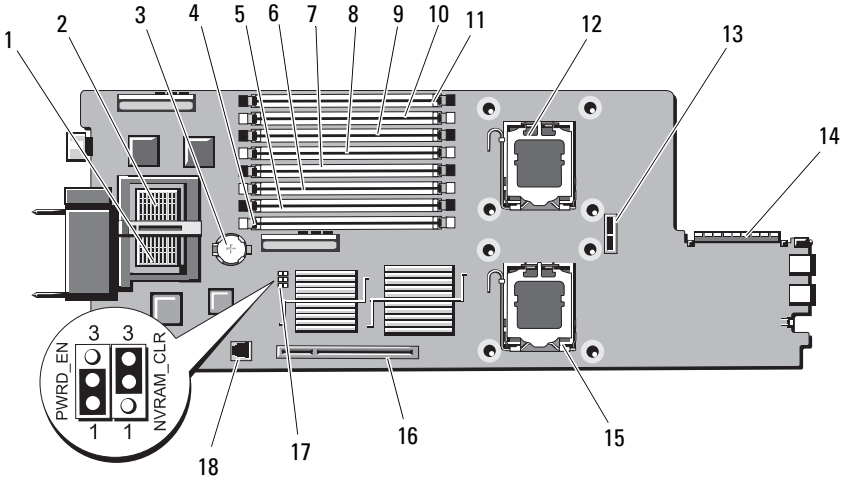
**Table 7-6. PowerEdge M805 System Board Connectors (continued)**

Connector	Description
7	connector for the 3.0-V coin battery <b>NOTE:</b> Access requires removal of system board. See "Removing the System Board" on page 150.
8 J_STORAGE	Storage controller card connector
9	Hard-drive backplane connector
10	Hardware key socket for integrated NIC TOE/iSCSI feature
11 CPU1	Processor 1 socket
12 A1 – A8	memory modules A1 – A8
13	video controller card connector
14 MEZZ1_FAB_C	Mezzanine card connector 1 Fabric C
15 MEZZ2_FAB_B	Mezzanine card connector 2 Fabric B
16 MEZZ3_FAB_C	Mezzanine card connector 3 Fabric C

**NOTE:** For the full name of an abbreviation or acronym used in this table, see the "Glossary" on page 219.

# PowerEdge M600 System Board

**Figure 7-3. PowerEdge M600 System Board Connectors**



**Table 7-7. PowerEdge M600 System Board Connectors**

Connector	Description
1	Mezzanine card connector - Fabric C
2	Mezzanine card connector - Fabric B
3 BATTERY	Connector for the 3.0-V coin battery
4 1	Memory module connector, slot 1
5 5	Memory module connector, slot 5
6 2	Memory module connector, slot 2
7 6	Memory module connector, slot 6
8 3	Memory module connector, slot 3
9 7	Memory module connector, slot 7
10 4	Memory module connector, slot 4
11 8	Memory module connector, slot 8
12 CPU1	Processor 1 socket

**Table 7-7. PowerEdge M600 System Board Connectors (continued)**

<b>Connector</b>	<b>Description</b>
13 SASBKPLN	Hard-drive backplane connector
14 J_STORAGE	Storage controller card connector
15 CPU2	Processor 2 socket
16 J_VIDEO	video controller card connector
17 PWRD_EN, NVRAM_CLR	Configuration jumpers
18 TOE_KEY	Hardware key socket for enabling the integrated NIC TOE/iSCSI feature

**NOTE:** For the full name of an abbreviation or acronym used in this table, see the "Glossary" on page 219.

# PowerEdge M605 System Board

Figure 7-4. PowerEdge M605 System Board Connectors

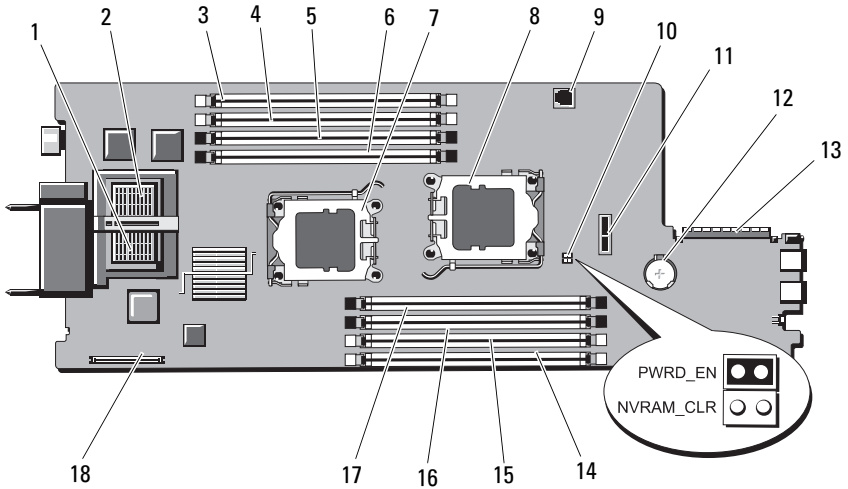


Table 7-8. PowerEdge M605 System Board Connectors

Connector	Description
1	Mezzanine card connector - Fabric C
2	Mezzanine card connector - Fabric B
3 A1	Memory module connector, slot A1
4 A2	Memory module connector, slot A2
5 A3	Memory module connector, slot A3
6 A4	Memory module connector, slot A4
7 CPU1	Processor 1 socket
8 CPU2	Processor 2 socket
9 TOE_KEY	Hardware key socket for enabling the integrated NIC TOE/iSCSI feature
10 PWRD_EN, NVRAM_CLR	Configuration jumpers
11 SASBKPLN	Hard-drive backplane connector


**Table 7-8. PowerEdge M605 System Board Connectors (continued)**

Connector	Description
12 BATTERY	Connector for the 3.0-V coin battery
13 J_STORAGE	Storage controller card connector
14 B1	Memory module connector, slot B1
15 B2	Memory module connector, slot B2
16 B3	Memory module connector, slot B3
17 B4	Memory module connector, slot B4
18 J_VIDEO	Video controller card connector

**NOTE:** For the full name of an abbreviation or acronym used in this table, see the "Glossary" on page 219.

## Disabling a Forgotten Password

The blade's software security features include a system password and a setup password, which are discussed in detail in "Using the System Setup Program" on page 79. The password jumper enables these password features or disables them and clears any password(s) currently in use.

 **CAUTION:** Many repairs may only be done by a certified service technician. You should only perform troubleshooting and simple repairs as authorized in your product documentation, or as directed by the online or telephone service and support team. Damage due to servicing that is not authorized by Dell is not covered by your warranty. Read and follow the safety instructions that came with the product.

- 1 Remove the blade. See "Removing a Blade" on page 96.
- 2 Open the blade. See "Opening the Blade" on page 100.
- 3 If you are changing the jumper setting on a PowerEdge M905 or M805 blade, remove the system board to gain access to the jumpers. See "Removing the System Board" on page 150.
- 4 Relocate the jumper plug to disable the password feature.

See Figure 7-1 (PowerEdge M905), Figure 7-2 (PowerEdge M805), Figure 7-3 (PowerEdge M600), or Figure 7-4 (PowerEdge M605) to locate the password jumper on the blade board.

- 5 If you are changing the jumper setting on a PowerEdge M905 or M805 blade, reinstall the system board. See "Installing the System Board" on page 153.
- 6 Close the blade. See "Closing the Blade" on page 104.
- 7 Install the blade. See "Installing a Blade" on page 98.  
When the blade is on, the power-on indicator is solid green. Allow the blade to finish booting.

The existing passwords are not disabled (erased) until the system boots with the password removed. However, before you assign a new system and/or setup password, you must reinstall the password jumper.



**NOTE:** If you assign a new system and/or setup password with the jumper removed, the system disables the new password(s) the next time it boots.

- 8 Remove the blade. See "Removing a Blade" on page 96.
- 9 Open the blade. See "Opening the Blade" on page 100.
- 10 If you are changing the jumper setting on a PowerEdge M905 or M805 blade, remove the system board to gain access to the jumpers. See "Removing the System Board" on page 150.
- 11 Relocate the jumper plug to enable the password feature.
- 12 If you are changing the jumper setting on a PowerEdge M905 or M805 blade, reinstall the system board. See "Installing the System Board" on page 153.
- 13 Close the blade. See "Closing the Blade" on page 104.
- 14 Install the blade. See "Installing a Blade" on page 98.
- 15 Assign a new system and/or setup password. See "System and Setup Password Features" on page 90.





# Getting Help

## Contacting Dell

For customers in the United States, call 800-WWW-DELL (800-999-3355).



**NOTE:** If you do not have an active Internet connection, you can find contact information on your purchase invoice, packing slip, bill, or Dell product catalog.

Dell provides several online and telephone-based support and service options. Availability varies by country and product, and some services may not be available in your area. To contact Dell for sales, technical support, or customer service issues:

- 1 Visit [support.dell.com](https://support.dell.com).
- 2 Verify your country or region in the **Choose A Country/Region** drop-down menu at the bottom of the page.
- 3 Click **Contact Us** on the left side of the page.
- 4 Select the appropriate service or support link based on your need.
- 5 Choose the method of contacting Dell that is convenient for you.



# Glossary

This section defines or identifies technical terms, abbreviations, and acronyms used in your system documents.

**A** — Ampere(s).

**AC** — Alternating current.

**ACPI** — Advanced Configuration and Power Interface. A standard interface for enabling the operating system to direct configuration and power management.

**ambient temperature** — The temperature of the area or room where the system is located.

**ANSI** — American National Standards Institute. The primary organization for developing technology standards in the U.S.

**application** — Software designed to help you perform a specific task or series of tasks. Applications run from the operating system.

**ASCII** — American Standard Code for Information Interchange.

**asset tag** — An individual code assigned to a system, usually by an administrator, for security or tracking purposes.

**backup** — A copy of a program or data file. As a precaution, back up your system's hard drive on a regular basis. Before making a change to the configuration of your system, back up important start-up files from your operating system.

**backup battery** — A battery that maintains system configuration, date, and time information in a special section of memory when the system is turned off.

**beep code** — A diagnostic message in the form of a pattern of beeps from your system's speaker. For example, one beep, followed by a second beep, and then a burst of three beeps is beep code 1-1-3.

**BIOS** — Basic input/output system. Your system's BIOS contains programs stored on a flash memory chip. The BIOS controls the following:

- Communications between the processor and peripheral devices
- Miscellaneous functions, such as system messages

**bit** — The smallest unit of information interpreted by your system.

**blade** — A module that contains a processor, memory, and a hard drive. The modules are mounted into a chassis that includes power supplies and fans.

**BMC** — Baseboard management controller.

**boot routine** — A program that clears all memory, initializes devices, and loads the operating system when you start your system. Unless the operating system fails to respond, you can reboot (also called *warm boot*) your system by pressing <Ctrl><Alt><Del>. Otherwise, you must restart the system by pressing the reset button or by turning the system off and then back on.

**bootable diskette** — A diskette that is used to start your system if the system will not boot from the hard drive.

**BTU** — British thermal unit.

**bus** — An information pathway between the components of a system. Your system contains an expansion bus that allows the processor to communicate with controllers for the peripheral devices connected to the system. Your system also contains an address bus and a data bus for communications between the processor and RAM.

**C** — Celsius.

**cache** — A fast storage area that keeps a copy of data or instructions for quick data retrieval. When a program makes a request to a disk drive for data that is in the cache, the disk-cache utility can retrieve the data from RAM faster than from the disk drive.

**CD** — Compact disc. CD drives use optical technology to read data from CDs.

**cm** — Centimeter(s).

**cmos** — Complementary metal-oxide semiconductor.

**component** — As they relate to DMI, components include operating systems, computer systems, expansion cards, and peripherals that are compatible with DMI. Each component is made up of groups and attributes that are defined as relevant to that component.

**COM** — The device names for the serial ports on your system.

**control panel** — The part of the system that contains indicators and controls, such as the power button and power indicator.

**controller** — A chip that controls the transfer of data between the processor and memory or between the processor and a peripheral.

**conventional memory** — The first 640 KB of RAM. Conventional memory is found in all systems. Unless they are specially designed, MS-DOS® programs are limited to running in conventional memory.

**coprocessor** — A chip that relieves the system's processor of specific processing tasks. A math coprocessor, for example, handles numeric processing.

**CPU** — Central processing unit. See *processor*.

**DC** — Direct current.

**DDR** — Double-data rate. A technology in memory modules that potentially doubles the output.

**device driver** — A program that allows the operating system or some other program to interface correctly with a peripheral. Some device drivers—such as network drivers—must be loaded from the `config.sys` file or as memory-resident programs (usually, from the `autoexec.bat` file). Others must load when you start the program for which they were designed.

**DHCP** — Dynamic Host Configuration Protocol. A method of automatically assigning an IP address to a client system.

**diagnostics** — A comprehensive set of tests for your system.

**DIMM** — Dual in-line memory module. See also *memory module*.

**DIN** — *Deutsche Industrie Norm*.

**directory** — Directories help keep related files organized on a disk in a hierarchical, “inverted tree” structure. Each disk has a “root” directory. Additional directories that branch off the root directory are called *subdirectories*. Subdirectories may contain additional directories branching off them.

**DMA** — Direct memory access. A DMA channel allows certain types of data transfer between RAM and a device to bypass the processor.

**DMI** — Desktop Management Interface. DMI enables the management of your system’s software and hardware by collecting information about the system’s components, such as the operating system, memory, peripherals, expansion cards, and asset tag.

**DNS** — Domain Name System. A method of translating Internet domain names, such as `www.dell.com`, into IP addresses, such as 143.166.83.200.

**DRAM** — Dynamic random-access memory. A system’s RAM is usually made up entirely of DRAM chips.

**DVD** — Digital versatile disc.

**ECC** — Error checking and correction.

**EEPROM** — Electronically erasable programmable read-only memory.

**EMC** — Electromagnetic compatibility.

**EMI** — Electromagnetic interference.

**ERA** — Embedded remote access. ERA allows you to perform remote, or “out-of-band,” server management on your network server using a remote access controller.

**ESD** — Electrostatic discharge.

**ESM** — Embedded server management.

**expansion bus** — Your system contains an expansion bus that allows the processor to communicate with controllers for peripherals, such as NICs.

**expansion card** — An add-in card, such as a NIC or SCSI adapter, that plugs into an expansion-card connector on the system board. An expansion card adds some specialized function to the system by providing an interface between the expansion bus and a peripheral.

**expansion-card connector** — A connector on the system board or riser board for plugging in an expansion card.

**F** — Fahrenheit.

**FAT** — File allocation table. The file system structure used by MS-DOS to organize and keep track of file storage. The Microsoft® Windows® operating systems can optionally use a FAT file system structure.

**flash memory** — A type of EEPROM chip that can be reprogrammed from a utility on diskette while still installed in a system; most EEPROM chips can only be rewritten with special programming equipment.

**format** — To prepare a hard drive or diskette for storing files. An unconditional format deletes all data stored on the disk.

**FSB** — Front-side bus. The FSB is the data path and physical interface between the processor and the main memory (RAM).

**ft** — Feet.

**FTP** — File transfer protocol.

**g** — Gram(s).

**G** — Gravities.

**Gb** — Gigabit(s); 1024 megabits or 1,073,741,824 bits.

**GB** — Gigabyte(s); 1024 megabytes or 1,073,741,824 bytes. However, when referring to hard-drive capacity, the term is usually rounded to 1,000,000,000 bytes.

**graphics mode** — A video mode that can be defined as  $x$  horizontal by  $y$  vertical pixels by  $z$  colors.

**group** — As it relates to DMI, a group is a data structure that defines common information, or attributes, about a manageable component.

**guarding** — A type of data redundancy in which a set of physical drives stores data and an additional drive stores parity data. See also *mirroring*, *striping*, and *RAID*.

**h** — Hexadecimal. A base-16 numbering system, often used in programming to identify addresses in the system's RAM and I/O memory addresses for devices. In text, hexadecimal numbers are often followed by *h*.

**headless system** — A system or device that functions without having a keyboard, mouse, or monitor attached. Normally, headless systems are managed over a network using an Internet browser.

**host adapter** — A host adapter implements communication between the system's bus and the controller for a peripheral device. (Hard-drive controller subsystems include integrated host adapter circuitry.) To add a SCSI expansion bus to your system, you must install or connect the appropriate host adapter.

**Hz** — Hertz.

**I/O** — Input/output. A keyboard is an input device, and a monitor is an output device. In general, I/O activity can be differentiated from computational activity.

**ID** — Identification.

**IDE** — Integrated drive electronics. A standard interface between the system board and storage devices.

**iDRAC** — Integrated Dell Remote Access Controller.

**integrated mirroring** — Provides simultaneous physical mirroring of two drives. Integrated mirroring functionality is provided by the system's hardware. See also *mirroring*.

**internal processor cache** — An instruction and data cache built into the processor.

**IP** — Internet Protocol.

**IPX** — Internet package exchange.

**IRQ** — Interrupt request. A signal that data is about to be sent to or received by a peripheral device travels by an IRQ line to the processor. Each peripheral connection must be assigned an IRQ number. Two devices can share the same IRQ assignment, but you cannot operate both devices simultaneously.

**jumper** — Small blocks on a circuit board with two or more pins emerging from them. Plastic plugs containing a wire fit down over the pins. The wire connects the pins and creates a circuit, providing a simple and reversible method of changing the circuitry in a board.

**K** — Kilo-; 1000.

**Kb** — Kilobit(s); 1024 bits.

**KB** — Kilobyte(s); 1024 bytes.

**Kbps** — Kilobit(s) per second.

**KBps** — Kilobyte(s) per second.

**key combination** — A command requiring you to press multiple keys at the same time (for example, <Ctrl><Alt><Del>).

**kg** — Kilogram(s); 1000 grams.

**kHz** — Kilohertz.

**KMM** — Keyboard/monitor/mouse.

**KVM** — Keyboard/video/mouse. KVM refers to a switch that allows selection of the system from which the video is displayed and for which the keyboard and mouse are used.

**iKVM** — Integrated keyboard/video/mouse module.

**LAN** — Local area network. A LAN is usually confined to the same building or a few nearby buildings, with all equipment linked by wiring dedicated specifically to the LAN.

**lb** — Pound(s).

**LCD** — Liquid crystal display.

**LED** — Light-emitting diode. An electronic device that lights up when a current is passed through it.

**Linux** — A UNIX-like operating system that runs on a variety of hardware systems. Linux is open source software, which is freely available; however, the full distribution of Linux along with technical support and training are available for a fee from vendors such as Red Hat Software.

**local bus** — On a system with local-bus expansion capability, certain peripheral devices (such as the video adapter circuitry) can be designed to run much faster than they would with a traditional expansion bus. See also *bus*.

**LVD** — Low voltage differential.

**m** — Meter(s).

**mA** — Milliampere(s).

**MAC address** — Media Access Control address. Your system's unique hardware number on a network.

**mAh** — Milliampere-hour(s).

**Mb** — Megabit(s); 1,048,576 bits.

**MB** — Megabyte(s); 1,048,576 bytes. However, when referring to hard-drive capacity, the term is often rounded to mean 1,000,000 bytes.

**Mbps** — Megabits per second.

**MBps** — Megabytes per second.

**MBR** — Master boot record.

**memory address** — A specific location, usually expressed as a hexadecimal number, in the system's RAM.



**memory module** — A small circuit board containing DRAM chips that connects to the system board.

**memory** — An area in your system that stores basic system data. A system can contain several different forms of memory, such as integrated memory (ROM and RAM) and add-in memory modules (DIMMs).

**MHz** — Megahertz.

**mirroring** — A type of data redundancy in which a set of physical drives stores data and one or more sets of additional drives stores duplicate copies of the data. Mirroring functionality is provided by software. See also *guarding*, *integrated mirroring*, *striping*, and *RAID*.

**mm** — Millimeter(s).

**MP** — Management panel.

**ms** — Millisecond(s).

**MS-DOS®** — Microsoft Disk Operating System.

**NAS** — Network Attached Storage. NAS is one of the concepts used for implementing shared storage on a network. NAS systems have their own operating systems, integrated hardware, and software that are optimized to serve specific storage needs.

**NIC** — Network interface controller. A device that is installed or integrated in a system to allow connection to a network.

**NMI** — Nonmaskable interrupt. A device sends an NMI to signal the processor about hardware errors.

**ns** — Nanosecond(s).

**NTFS** — The NT File System option in the Windows 2000 operating system.

**NVRAM** — Nonvolatile random-access memory. Memory that does not lose its contents when you turn off your system. NVRAM is used for maintaining the date, time, and system configuration information.

**parity** — Redundant information that is associated with a block of data.

**partition** — You can divide a hard drive into multiple physical sections called *partitions* with the **fdisk** command. Each partition can contain multiple logical drives. You must format each logical drive with the **format** command.

**PCI** — Peripheral Component Interconnect. A standard for local-bus implementation.

**PDU** — Power distribution unit. A power source with multiple power outlets that provides electrical power to servers and storage systems in a rack.

**peripheral** — An internal or external device, such as a diskette drive or keyboard, connected to a system.

**PGA** — Pin grid array. A type of processor socket that allows you to remove the processor chip.

**pixel** — A single point on a video display. Pixels are arranged in rows and columns to create an image. A video resolution, such as 640 x 480, is expressed as the number of pixels across by the number of pixels up and down.

**POST** — Power-on self-test. Before the operating system loads when you turn on your system, the POST tests various system components such as RAM and hard drives.

**processor** — The primary computational chip inside the system that controls the interpretation and execution of arithmetic and logic functions. Software written for one processor must usually be revised to run on another processor. *CPU* is a synonym for processor.

**protected mode** — An operating mode that allows operating systems to implement:

- A memory address space of 16 MB to 4 GB
- Multitasking
- Virtual memory, a method for increasing addressable memory by using the hard drive

The Windows 2000 and UNIX 32-bit operating systems run in protected mode. MS-DOS cannot run in protected mode.

**PS/2** — Personal System/2.

**PXE** — Preboot eXecution Environment. A way of booting a system via a LAN (without a hard drive or bootable diskette).

**RAC** — Remote access controller.

**RAID** — Redundant array of independent disks. A method of providing data redundancy. Some common implementations of RAID include RAID 0, RAID 1, RAID 5, RAID 10, and RAID 50. See also *guarding*, *mirroring*, and *striping*.

**RAM** — Random-access memory. The system's primary temporary storage area for program instructions and data. Any information stored in RAM is lost when you turn off your system.

**RAS** — Remote Access Service. This service allows users running the Windows operating system to remotely access a network from their system using a modem.

**readme file** — A text file, usually shipped with software or hardware, that contains information supplementing or updating the product's documentation.

**read-only file** — A read-only file is one that you are prohibited from editing or deleting.

**ROM** — Read-only memory. Your system contains some programs essential to its operation in ROM code. A ROM chip retains its contents even after you turn off your

system. Examples of code in ROM include the program that initiates your system's boot routine and the POST.

**ROMB** — RAID on motherboard.

**rpm** — Revolutions per minute.

**RTC** — Real-time clock.

**SAS** — Serial-attached SCSI.

**SATA** — Serial Advanced Technology Attachment. A standard interface between the system board and storage devices.

**SCSI** — Small computer system interface. An I/O bus interface with faster data transmission rates than standard ports.

**SDRAM** — Synchronous dynamic random-access memory.

**sec** — Second(s).

**serial port** — An I/O port used most often to connect a modem to your system. You can usually identify a serial port on your system by its 9-pin connector.

**service tag** — A bar code label on the system used to identify it when you call Dell for technical support.

**simple disk volume** — The volume of free space on a single dynamic, physical disk.

**SIP** — Server interface pod.

**SMART** — Self-Monitoring Analysis and Reporting Technology. Allows hard drives to report errors and failures to the system BIOS and then display an error message on the screen.

**SMP** — Symmetric multiprocessing. Used to describe a system that has two or more processors connected via a high-bandwidth link and managed by an operating system, where each processor has equal access to I/O devices.

**SNMP** — Simple Network Management Protocol. A standard interface that allows a network manager to remotely monitor and manage workstations.

**spanning** — Spanning, or concatenating, disk volumes combines unallocated space from multiple disks into one logical volume, allowing more efficient use of all the space and all drive letters on a multiple-disk system.

**striping** — Disk striping writes data across three or more disks in an array, but only uses a portion of the space on each disk. The amount of space used by a "stripe" is the same on each disk used. A virtual disk may use several stripes on the same set of disks in an array. See also *guarding*, *mirroring*, and *RAID*.

**SVGA** — Super video graphics array. VGA and SVGA are video standards for video adapters with greater resolution and color display capabilities than previous standards.

**system board** — As the main circuit board, the system board usually contains most of your system's integral components, such as the processor, RAM, controllers for peripherals, and various ROM chips.

**system configuration information** — Data stored in memory that tells a system what hardware is installed and how the system should be configured for operation.

**system diskette** — See *bootable diskette*.

**system memory** — See *RAM*.

**System Setup program** — A BIOS-based program that allows you to configure your system's hardware and customize the system's operation by setting features such as password protection. Because the System Setup program is stored in NVRAM, any settings remain in effect until you change them again.

**system.ini file** — A start-up file for the Windows operating system. When you start Windows, it consults the **system.ini** file to determine a variety of options for the Windows operating environment. Among other things, the **system.ini** file records which video, mouse, and keyboard drivers are installed for Windows.

**TCP/IP** — Transmission Control Protocol/Internet Protocol.

**termination** — Some devices (such as the last device at each end of a SCSI cable) must be terminated to prevent reflections and spurious signals in the cable. When such devices are connected in a series, you may need to enable or disable the termination on these devices by changing jumper or switch settings on the devices or by changing settings in the configuration software for the devices.

**TOE** — TCP/IP offload engine.

**UNIX** — Universal Internet Exchange. UNIX, the precursor to Linux, is an operating system written in the C programming language.

**uplink port** — A port on a network hub or switch used to connect to other hubs or switches without requiring a crossover cable.

**UPS** — Uninterruptible power supply. A battery-powered unit that automatically supplies power to your system in the event of an electrical failure.

**USB** — Universal Serial Bus. A USB connector provides a single connection point for multiple USB-compliant devices, such as mice and keyboards. USB devices can be connected and disconnected while the system is running.

**utility** — A program used to manage system resources—memory, disk drives, or printers, for example.

**UTP** — Unshielded twisted pair. A type of wiring used to connect systems in a business or home to a telephone line.

**V** — Volt(s).

**VAC** — Volt(s) alternating current.

**VDC** — Volt(s) direct current.

**VGA** — Video graphics array. VGA and SVGA are video standards for video adapters with greater resolution and color display capabilities than previous standards.

**video adapter** — The logical circuitry that provides (in combination with the monitor) your system's video capabilities. A video adapter may be integrated into the system board or may be an expansion card that plugs into an expansion slot.

**video driver** — A program that allows graphics-mode application programs and operating systems to display at a chosen resolution with the desired number of colors. Video drivers may need to match the video adapter installed in the system.

**video memory** — Most VGA and SVGA video adapters include memory chips in addition to your system's RAM. The amount of video memory installed primarily influences the number of colors that a program can display (with the appropriate video drivers and monitor capabilities).

**video resolution** — Video resolution (800 x 600, for example) is expressed as the number of pixels across by the number of pixels up and down. To display a program at a specific graphics resolution, you must install the appropriate video drivers and your monitor must support the resolution.

**W** — Watt(s).

**WH** — Watt-hour(s).

**win.ini file** — A start-up file for the Windows operating system. When you start Windows, it consults the **win.ini** file to determine a variety of options for the Windows operating environment. The **win.ini** file also usually includes sections that contain optional settings for Windows application programs that are installed on the hard drive.

**Windows 2000** — An integrated and complete Microsoft Windows operating system that does not require MS-DOS and that provides advanced operating system performance, improved ease of use, enhanced workgroup functionality, and simplified file management and browsing.

**Windows Powered** — A Windows operating system designed for use on NAS systems. For NAS systems, the Windows Powered operating system is dedicated to file service for network clients.

**Windows Server 2003** — A set of Microsoft software technologies that enable software integration through the use of XML Web services. XML Web services are small reusable applications written in XML that allow data to be communicated between otherwise unconnected sources.

**XML** — Extensible Markup Language. XML is a way to create common information formats and to share both the format and the data on the World Wide Web, intranets, and elsewhere.

**ZIF** — Zero insertion force.

# Index

## A

- AC power present indicator, 29
- asset tag utility, 94

## B

- batteries
  - troubleshooting, 195
- battery, 140
  - installing, 140
  - removing, 140
- blade board
  - troubleshooting, 194
- blade power button, 22
- blades
  - closing, 104
  - installing, 98
  - opening, 100
  - processors, 128
  - removing, 96
- boot drive
  - configuring, 144

## C

- checking equipment, 180
- closing
  - blades, 104

- CMC module, 38, 162
  - fault indicator, 39
  - installing, 165-166
  - link activity indicator, 39
  - link indicator, 39
  - removing, 162, 166
  - status indicator, 39
  - troubleshooting, 187

- configuring
  - boot drive, 144
- connectors
  - system board, 207
- contacting Dell, 217

## D

- Dell
  - contacting, 217
- diagnostics
  - advanced testing options, 200
  - error messages, 201
  - running from the utility partition, 198
  - see *system diagnostics* and *Server Administrator diagnostics*
  - testing options, 199
- drive carrier
  - hard drive, 144

## E

error messages, 79

## F

fan module indicators, 29

fans

installing, 162

removing, 161

troubleshooting, 186

features

back-panel, 26

blade, 20

blade power button, 22

CMC module, 38

Fibre Channel pass-through  
module, 58

Fibre Channel switch  
module, 61-63

Gb Ethernet pass-through  
module, 64

hard drive, 23

I/O connectivity, 42

PowerConnect Ethernet  
switch, 53-54

system, 12

Fibre Channel pass-through  
module, 58

Fibre Channel switch  
module, 61-63

## G

Gb Ethernet pass-through  
module, 64

getting help, 217

guidelines

memory installation, 106, 109,  
115

## H

hard drive

installing in a drive carrier, 144

removing from a drive carrier, 144

hard drives, 142

features, 23

installing, 142

removing, 143

troubleshooting, 192

hard-drive backplane

installing, 148

removing, 148

help

getting, 217

## I

I/O bays

populating, 42

I/O module, 166

installing, 167

removing, 166



- iKVM module, 166
  - features, 31
  - installing, 166
  - removing, 166
  - tiering, 33
- indicators
  - AC power present, 29
  - CMC fault, 39
  - CMC link, 39
  - CMC link activity, 39
  - CMC status, 39
  - fan module, 29
  - Fibre Channel pass-through module, 54, 60, 63
  - power supply, 27
  - power supply fault, 28, 30
  - server module power selection, 22
  - system power, 15
- installing
  - battery, 140
  - blades, 98
  - CMC module, 165-166
  - fans, 162
  - hard drive in a drive carrier, 144
  - hard drives, 142
  - I/O module, 167
  - memory, 120
  - memory guidelines, 106, 109, 115
  - mezzanine card, 123
  - power supplies, 160

## **K**

- keyboards
  - troubleshooting, 181

## **M**

- memory
  - installing, 120
  - troubleshooting, 191
- memory modules
  - removing, 122
- messages
  - alert, 78
  - blade, 66
  - error messages, 79
  - system diagnostics, 78
  - systems management, 183
  - warning, 77
- mezzanine card
  - installing, 123
- microprocessors
  - troubleshooting, 193
- mouse
  - troubleshooting, 182

## **N**

- network switch module
  - troubleshooting, 189
- NVRAM backup, 140

## O

- opening
  - blades, 100
- options
  - system setup, 80

## P

- password
  - disabling, 214
- password features
  - setup, 90
  - system, 90
- passwords
  - disabling, 94
  - setup, 93
  - system, 90
- phone numbers
  - obtaining, 217
- power supplies, 158
  - installing, 160
  - removing, 159
  - troubleshooting, 186
- PowerConnect Ethernet switch
  - module, 53-54
- processors
  - blades, 128

## R

- removing
  - battery, 140
  - blades, 96
  - CMC module, 162, 166
  - fans, 161
  - hard drive, 143
  - hard drive from a drive carrier, 144
  - I/O module, 166
  - memory, 122
  - power supplies, 159

## S

- safety, 179
- securing your system, 91
- server module components
  - troubleshooting, 191
- setup password
  - assigning, 93
  - changing, 94
  - using, 93
- setup password enabled
  - working with, 93
- setup password features, 90
- support
  - contacting Dell, 217
- system board
  - connectors, 207

- system control panel, 14
- system fans, 161
- system features, 12
- system password
  - assigning, 90
  - changing, 92
  - deleting, 92
  - using, 90
- system password features, 90
- system power button, 15
- system power indicator, 15
- system setup
  - entering, 79
  - options, 80
  - using, 80
- system setup screens
  - console redirection, 86
  - integrated devices, 85
  - main, 80
  - system security, 87

## **T**

- technical assistance
  - obtaining, 217
- telephone numbers
  - obtaining, 217
- troubleshooting
  - battery, 195
  - blade board, 194

troubleshooting (*continued*)

- CMC module, 187
- external connections, 180
- fans, 186
- hard drive, 192
- keyboard, 181
- memory, 191
- microprocessors, 193
- mouse, 182
- network switch module, 189
- power supplies, 186
- server module components, 191
- start-up routine, 179
- USB devices, 183

## **U**

### **USB**

- devices, troubleshooting, 183
- using system setup, 80

## **V**

- video controller
  - installing, 147

## **W**

- warranty, 11

