

Motherboard Layout and Features

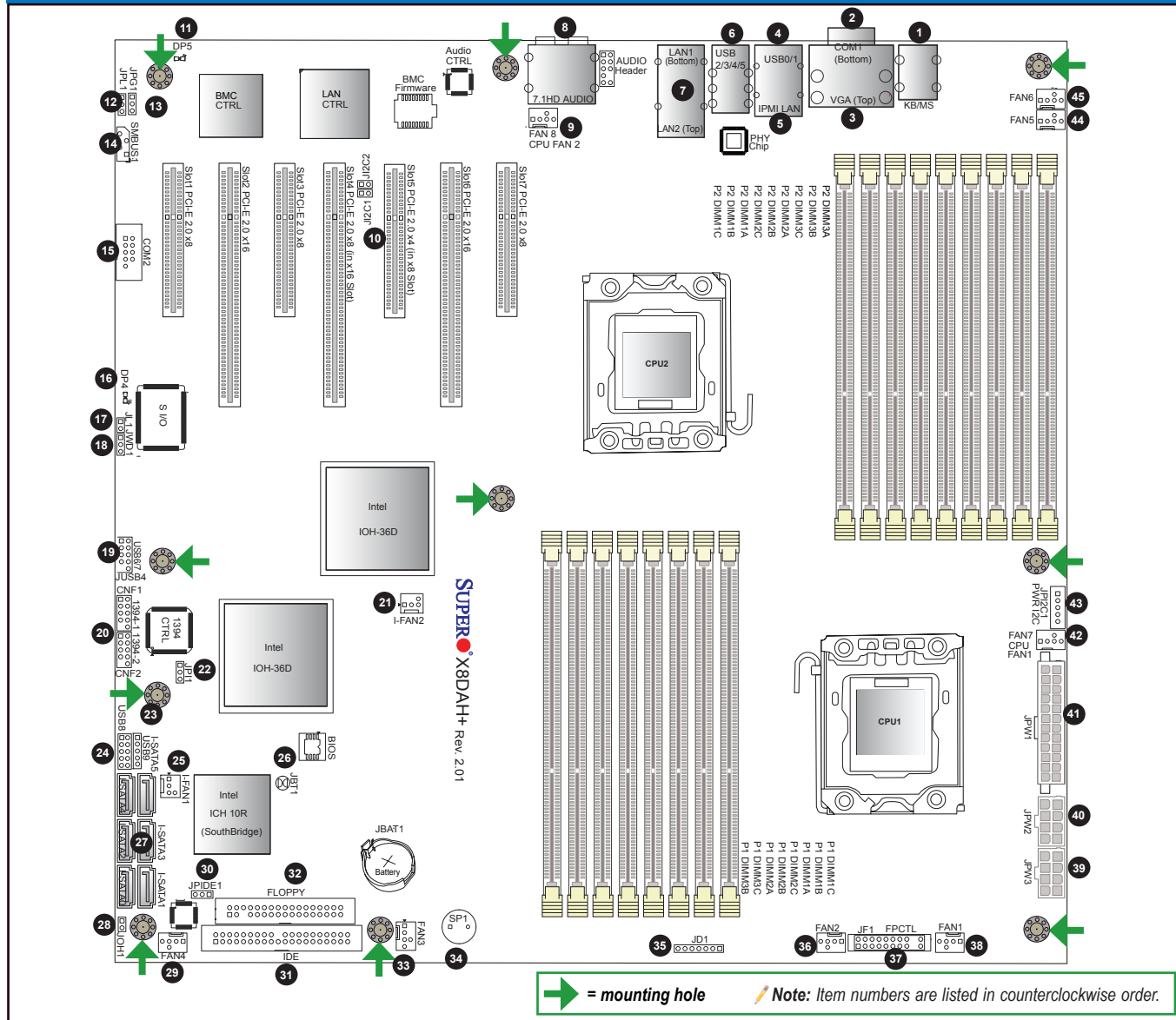

Jumpers, Connectors, and LED Indicators

Jumpers

Jumper	Item #	Description	Default
JBT1	26	CMOS Clear	Open (Normal)
Ji ² C1/Ji ² C2	10	SMB to PCI/PCI-E Slots	Open/Open (Disabled)
JPG1	13	VGA Enable	Pins 1-2 (Enabled) (X8DAH+/-F/(-LR) only)
JPI1	22	1394-1/1394 Enable	Pins 1-2 (Enabled)
JPIDE1	30	Compact Flash Enabled	Closed (Enabled)
JPL1	12	LAN1/2 Enable	Pins 1-2 (Enabled)
JWD1	18	Watch Dog	Pins 1-2 (Reset)

Connectors

Connectors	Item#	Description
Audio Connections	8	BP 7.1 HD Audio, BP Audio Header, CD In
CNF1/CNF2	20	1394a-1/2 Ports
COM1/COM2	2, 15	Backplane Serial Port/FP Serial Header
FAN 1-4	38, 36, 33, 29	System/CPU Fan Headers (CPU Fans 1 & 2)
FAN 5-8	44, 45, 42, 9	System Fan Headers (Fan7 = CPU Fan1, Fan8 = CPU Fan2)
Floppy	32	Floppy Drive
IDE	31	IDE Drive
I-FAN 1, I-FAN 2	21, 25	Fans 1 & 2 Headers for IOH Chips 1 & 2
IPMI LAN	5	Dedicated IPMI LAN (X8DAH+/-F only)
JD1	35	PWR LED/Speaker Header (Pins 1~3: Power LED, Pins 6~7: Onboard Buzzer, Pins 4~7: External Speaker)
JF1	37	Front Panel Connector
JL1	17	Chassis Intrusion Header
JOH1	28	Overheat LED Header
JPI ² C1	43	Power Supply SMBbus I ² C Header
JPW1	41	24-pin ATX PWR,
JPW2/JPW3	40, 39	8-pin Secondary PWR
KB, Mouse	1	PS2 Keyboard and Mouse
LAN1, LAN2	7	G-LAN (RJ45) Ports (Dedicated LAN: X8DAH+/-F/(-LR))
I-SATA0 ~ I-SATA5	27	(Intel South Bridge) SATA Ports
SMBUS1	14	System Management Bus Header
SP1	34	Onboard Buzzer/Internal Speaker
USB 0/1, 2-5	4, 6	Backpanel Universal Serial Bus (USB) Ports 0/1, 2-5
USB 6/7, 8, 9	19, 24, 23	Front Panel (Accessible) USB Ports 6/7, USB 8, USB 9
VGA	3	Onboard Video Display (X8DAH+/-F/(-LR) only)

LED Indicators

LED	Item#	Description	State	Status
DP4	16	Onboard Standby PWR	On	System Power On
DP5	11	BMC Heartbeat LED	Blinking	BMC Normal

Memory Support

This motherboard supports up to 288 GB of Registered (RDIMM)/Load Reduced (LRDIMM) ECC or up to 48 GB of Unbuffered (UDIMM) ECC/Non-ECC DDR3 800/1066/1333 MHz 3-channel (per CPU) memory in 18 DIMM slots.

Note: For memory optimization, use only DIMM modules that have been validated by Supermicro. For the latest memory updates, please refer to our website at <http://www.supermicro.com/products/motherboard>.

DIMM Installation

Insert the desired number of DIMMs into the memory slots, starting with P1-DIMM1A. For memory to work properly, follow the tables below for memory population order. Refer to the motherboard layout (at left) for the location of the DIMM slots.

Memory Population for Optimal Performance for PCB Rev. 2.0 or Newer Boards with One CPU Installed in CPU Socket 1

P1-DIMMs	To Populate P1-DIMMs								
	Branch 0			Branch 1			Branch 2		
3 DIMMs	P1-1A			P1-2A			P1-3A		
6 DIMMs	P1-1A	P1-1B		P1-2A	P1-2B		P1-3A	P1-3B	
9 DIMMs (RDIMMs only)	P1-1A	P1-1B	P1-1C	P1-2A	P1-2B	P1-2C	P1-3A	P1-3B	P1-3C

Note: Max. of 6 UDIMM modules are supported by a CPU.

Memory Population for Optimal Performance for PCB Rev. 2.0 or Newer Boards with Two CPUs Installed in CPU Sockets 1 & 2

	CPU 1 (To Populate P1-DIMMs)			CPU 2 (To Populate P2-DIMMs)		
	Branch 0	Branch 1	Branch 2	Branch 0	Branch 1	Branch 2
6 DIMMs	P1-1A	P1-2A	P1-3A	P2-1A	P2-2A	P2-3A
12 DIMMs	P1-1A/1B	P1-2A/2B	P1-3A/3B	P2-1A/1B	P2-2A/2B	P2-3A/3B
18 DIMMs (For RDIMMs only)	P1-1A/1B/1C	P1-2A/2B/2C	P1-3A/3B/3C	P2-1A/1B/1C	P2-2A/2B/2C	P2-3A/3B/3C

Note: Max. of 6 UDIMM modules are supported by a CPU.

CPU Installation

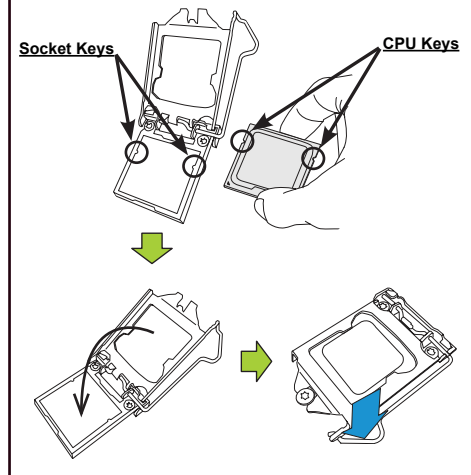

Heatsink Installation

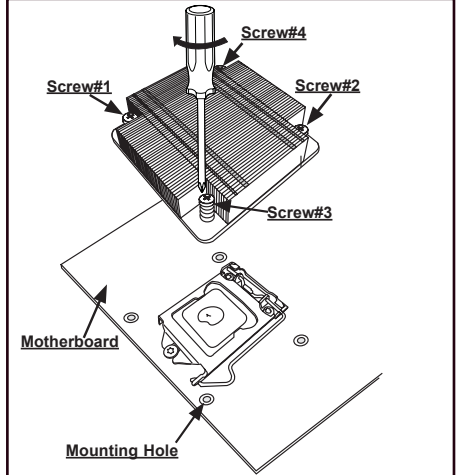

Front Panel Control (JF1)

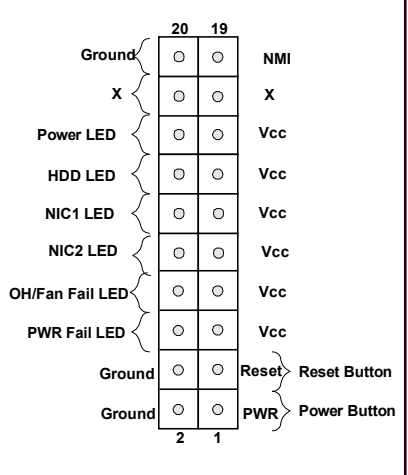

Back Panel I/O Connectors

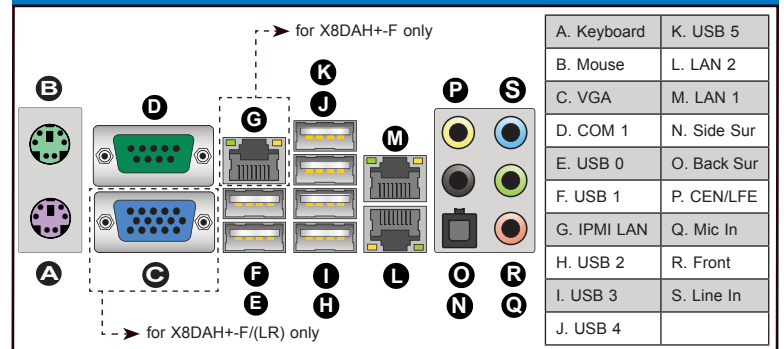

Note: Graphics shown in this quick guide are for illustration only. Your components may or may not look exactly the same as drawings shown in this guide.

Note: Refer to Chapter 2 of the User Manual on detailed information on jumpers, connectors, and LED indicators.

Note: Refer to Chapter 2 of the User Manual for detailed information on memory support and CPU/motherboard installation instructions.