

Dell EMC PowerEdge R7415

Technical specifications

Notes, cautions, and warnings

 **NOTE:** A NOTE indicates important information that helps you make better use of your product.

 **CAUTION:** A CAUTION indicates either potential damage to hardware or loss of data and tells you how to avoid the problem.

 **WARNING:** A WARNING indicates a potential for property damage, personal injury, or death.

© 2017 - 2018 Dell Inc. or its subsidiaries. All rights reserved. Dell, EMC, and other trademarks are trademarks of Dell Inc. or its subsidiaries. Other trademarks may be trademarks of their respective owners.

Contents

1 Dell EMC PowerEdge R7415 overview.....	4
2 Technical specifications.....	5
System dimensions.....	6
Chassis weight.....	6
Processor specifications.....	7
PSU specifications.....	7
System battery specifications.....	7
Expansion bus specifications.....	7
Memory specifications.....	7
Drive specifications.....	8
Drives.....	8
Ports and connectors specifications.....	8
USB ports.....	8
NIC ports.....	9
Serial connector.....	9
VGA ports.....	9
Internal Dual SD Module.....	9
Video specifications.....	9
Environmental specifications.....	10
Particulate and gaseous contamination specifications	11
Standard operating temperature.....	12
Expanded operating temperature.....	12
Thermal restriction matrix.....	13
3 Documentation resources.....	15
4 Getting help.....	17
Contacting Dell.....	17
Documentation feedback.....	17
Accessing system information by using QRL.....	17
Quick Resource Locator for PowerEdge R7415.....	18
Receiving automated support with SupportAssist	18

Dell EMC PowerEdge R7415 overview

The PowerEdge R7415 is a 2U, single socket rack system and support these configurations:

- One AMD EPYC™ processor
- Sixteen DIMM slots
- Two redundant power supply units (PSU) or single cabled PSU
- 8 x 3.5 inch, 12 x 3.5 inch, 12 x 3.5 inch + 2 x 3.5 inch (rear), or 24 x 2.5 inch SAS, SATA, or NVMe drives (up to 12 SAS/SATA/NVMe + 12 NVMe drives), 8 x 2.5 inch (universal drive) + 16 (NVMe drive), 24 x 2.5 inch (NVMe drive only).

NOTE: Hot swap for the NVMe drives is supported for your system. For more information on correct usage and technical specifications, see the *Dell PowerEdge Express Flash NVMe PCIe SSD 2.5 inch Small Form Factor User's Guide* at [Dell.com/support/manuals > All Products > Server, Storage, & Networking > Dell Adapters page](https://www.dell.com/support/manuals/all-products/server-storage-networking/dell-adapters).

NOTE: All instances of SAS, SATA hard drives, SSDs and NVMe drives are referred to as drives in this document, unless specified otherwise.

Technical specifications

The technical and environmental specifications of your system are outlined in this section.

Topics:

- System dimensions
- Chassis weight
- Processor specifications
- PSU specifications
- System battery specifications
- Expansion bus specifications
- Memory specifications
- Drive specifications
- Ports and connectors specifications
- Video specifications
- Environmental specifications

System dimensions

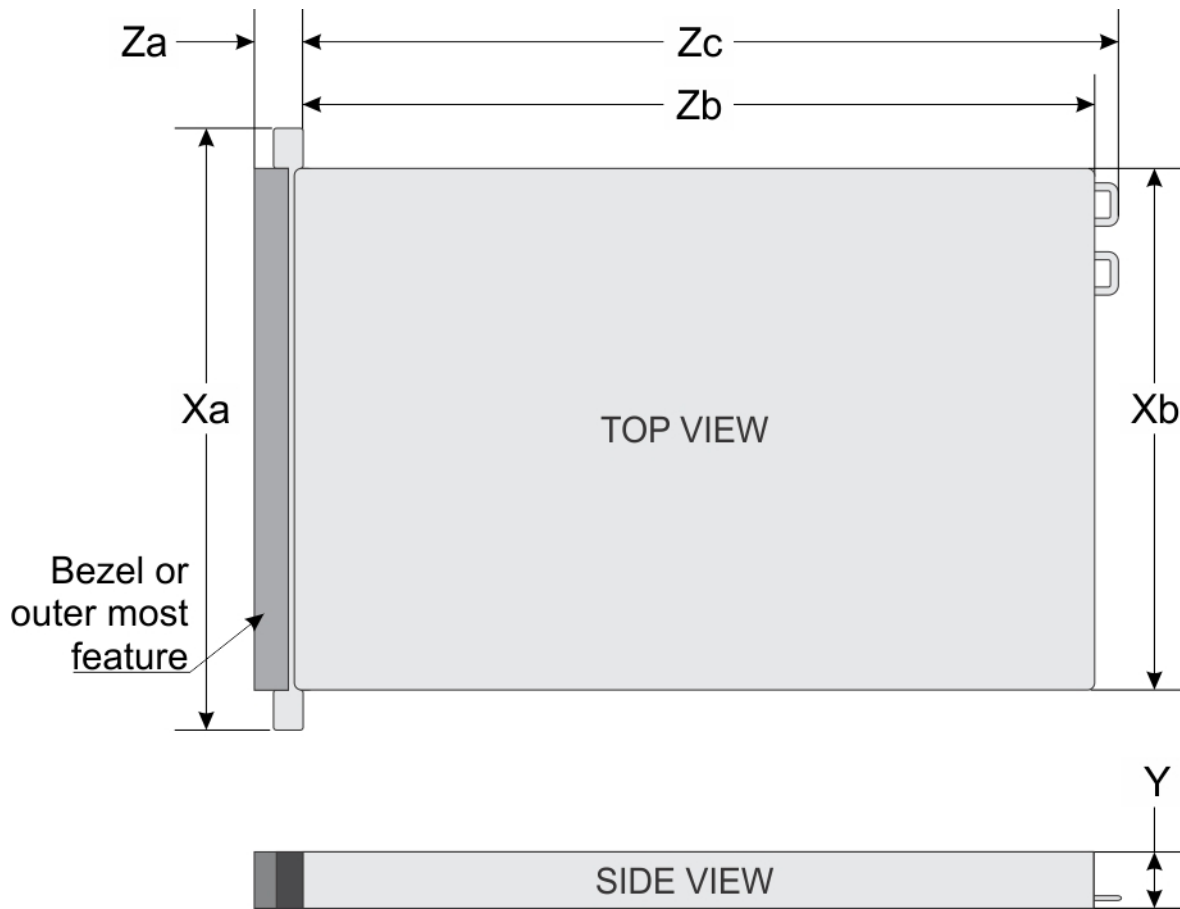

Figure 1. Dimensions of the PowerEdge R7415 system

Table 1. Dimensions of the PowerEdge R7415 system

Xa	Xb	Y	Za (with bezel)	Za (without bezel)	Zb*	Zc
482 mm (18.97 inches)	434 mm (17.08 inches)	86.8 mm (3.41 inches)	35.84 mm (1.41 inches)	22 mm (0.87 inches)	647.07 mm (25.47 inches)	681.755 mm (26.84 inches)

* - Zb goes to the nominal rear wall external surface where the system board I/O connectors are located.

Chassis weight

Table 2. Chassis weight

System	Maximum weight (with all drives/SSDs)
8 x 3.5 inch	24.4 kg (53.79 lb)
12 x 3.5 inch	26.61 kg (58.66 lb)
12 x 3.5 inch + 2 x 3.5 inch (rear)	28.21 kg (62.19 lb)

System	Maximum weight (with all drives/SSDs)
24 x 2.5 inch	23.22 kg (51.19 lb)

Processor specifications

The PowerEdge R7415 system support one AMD EPYC™ processor.

PSU specifications

The PowerEdge R7415 system supports the following AC or DC power supply units (PSU).

Table 3. PSU specifications

PSU	Class	Heat dissipation (maximum)	Frequency	Voltage
1600 W AC	Platinum	6000 BTU/hr	50/60 Hz	100–240 V AC, autoranging
1100 W AC	Platinum	4100 BTU/hr	50/60 Hz	100–240 V AC, autoranging
1100 W HVDC	Platinum	4100 BTU/hr	50/60 Hz	100–240 V AC autoranging and 200–380 V DC
1100 W DC	Platinum	4416 BTU/hr	-	(-(48–60)) V DC
750 W AC	Titanium	2843 BTU/hr	50/60 Hz	200–240 V AC, autoranging
750 W AC	Platinum	2891 BTU/hr	50/60 Hz	100–240 V AC, autoranging
750 W HVDC	Platinum	2891 BTU/hr	50/60 Hz	100–240 V AC autoranging and 240 V DC
495 W AC	Platinum	1908 BTU/hr	50/60 Hz	100–240 V AC, autoranging
450 W AC	Bronze	1871 BTU/hr	50/60 Hz	100–240 V AC, autoranging

NOTE: Heat dissipation is calculated using the PSU wattage rating.

NOTE: This system is also designed to connect to the IT power systems with a phase-to-phase voltage not exceeding 230 V.

NOTE: If a system with 1600 W AC PSU operates at low line 100-120 V AC, then the power rating per PSU is derated to 800 W.

NOTE: If a system with 1100 W AC PSU or 1100 W mixed mode PSU operates at low line 100-120 V AC, then the power rating per PSU is derated to 1050 W.

System battery specifications

The PowerEdge R7415 system supports CR 2032 3.0-V lithium coin cell system battery.

Expansion bus specifications

The PowerEdge R7415 system supports PCI Express (PCIe) Gen3 expansion cards, which need to be installed on the system board using expansion card risers. The PowerEdge R7415 system supports three types of expansion card risers.

Memory specifications

The PowerEdge R7415 system supports 16 DDR4 DIMM (registered DIMM (RDIMM) and load reduced DIMM (LRDIMM)) slots. Supported memory bus frequencies are 2666 MT/s, 2400 MT/s, 2133 MT/s, and 1866 MT/s.

Table 4. Memory specifications

Memory module sockets	Memory capacity	Minimum RAM	Maximum RAM
Sixteen 288-pin	<ul style="list-style-type: none">8 GB, 16 GB, or 32 GB single rank or dual rank (RDIMMs)64 or 128 GB* quad rank or octal rank (LRDIMMs)	<ul style="list-style-type: none">8 GB with single processor	<ul style="list-style-type: none">Up to 2 TB with a single processor

* - Maximum DIMM/memory capacity of 128 GB will be available at a later time.

NOTE: For optimal performance, populate one DIMM per channel with DDR4-2666 memory modules on the first slot of each memory channel. The first slot of each channel can be identified as the DIMM slots with white latches. For example, 64 GB system memory capacity can be divided into 8 x 8 GB DIMM slots.

Drive specifications

Drives

The PowerEdge R7415 system supports:

- Up to 8 x 3.5 inch (SAS, SATA or Nearline SAS) front accessible drives in slots 0 to 7
or
- Up to 12 x 3.5 inch (SAS, SATA or Nearline SAS) front accessible drives in slots 0 to 11
or
- Up to 12 x 3.5 inch (SAS, SATA or Nearline SAS) front accessible drives in slots 0 to 11 + up to 2 x 3.5 inch (SAS, SATA or Nearline SAS) rear accessible drives in slots 12 to 13
or
- Up to 24 x 2.5 inch (SAS, SATA or Nearline SAS) front accessible drives in slots 0 to 23
or
- Up to 12 x 2.5 inch (SAS, SATA or Nearline SAS) front accessible drives in slots 0 to 11 and up to 12 x 2.5 inch NVMe drives in 12 universal slots 12 to 23
or
- Up to 24 x 2.5 inch NVMe drives in bay 0 (slot 0 to 11) and bay 1 (slots 0 to 11)
or
- Up to 8 x 2.5 inch (SAS, SATA or Nearline SAS) front accessible drives in Universal slots 0 to 7 (Bay 0) and up to 16 x 2.5 inch NVMe drives in bay 0 (slots 8 to 11) and bay 1 (slots 0 to 11)

NOTE: Hot swap for the NVMe drives is supported for your system. For more information on correct usage and technical specifications, see the [Dell PowerEdge Express Flash NVMe PCIe SSD 2.5 inch Small Form Factor User's Guide at Dell.com/support/manuals > All Products > Server, Storage, & Networking > Dell Adapters page.](#)

NOTE: Universal slots that support SAS, SATA hard drives/SSDs, or NVMe drives in the same slot.

Ports and connectors specifications

USB ports

The PowerEdge R7415 system supports:

- USB 2.0-compliant port on the front panel
- USB 3.0-compliant port on the back panel
- USB 3.0-compliant internal port

The following table provides more information about the USB specifications:

Table 5. USB specifications

Front panel	Back panel	Internal USB
<ul style="list-style-type: none"> • Three USB 2.0-compliant port (One iDRAC Direct (Micro-AB USB) port + two USB 2.0 port) 	<ul style="list-style-type: none"> • Two USB 3.0-compliant port 	<ul style="list-style-type: none"> • One internal USB 3.0 port

NOTE: The Micro-AB USB 2.0-compliant port on the front panel can be used only as an iDRAC Direct or a management port.

NIC ports

The PowerEdge R7415 system supports two Network Interface Controller (NIC) ports on the back panel, which have two 1 Gbps configuration.

NOTE: You can install up to four PCIe add-on NIC cards.

NOTE: For information about Linux network performance settings, see the *Linux® Network Tuning Guide for AMD EPYC™ Processor Based Servers* AMD tuning guide.

Serial connector

The serial connector connects a serial device to the system. The PowerEdge R7415 system supports one serial connector on the back panel, which is a 9-pin connector, Data Terminal Equipment (DTE), 16550-compliant.

VGA ports

The Video Graphic Array (VGA) port enables you to connect the system to a VGA display. The PowerEdge R7415 system supports two 15-pin VGA ports one each on the front and back panels.

Internal Dual SD Module

The PowerEdge R7415 system supports two optional flash memory card slots with an internal dual MicroSD module.

NOTE: One card slot is dedicated for redundancy.

Video specifications

The PowerEdge R7415 system supports Matrox G200eR2 graphics card with 16 MB capacity.

Table 6. Supported video resolution options

Resolution	Refresh rate (Hz)	Color depth (bits)
1024 x 768	60	8, 16, 32
1280 x 800	60	8, 16, 32
1280 x 1024	60	8, 16, 32
1360 x 768	60	8, 16, 32
1440 x 900	60	8, 16, 32
1600 x 900	60	8, 16, 32
1600 x 1200	60	8, 16, 32
1680 x 1050	60	8, 16, 32
1920 x 1080	60	8, 16, 32
1920 x 1200	60	8, 16, 32

NOTE: 1920 x 1080 and 1920 x 1200 resolutions are only supported in reduced blanking mode.

Environmental specifications

NOTE: For additional information about environmental measurements for specific system configurations, see Dell.com/environmental_datasheets.

Table 7. Temperature specifications

Temperature	Specifications
Storage	–40°C to 65°C (–40°F to 149°F)
Continuous operation (for altitude less than 950 m or 3117 ft)	10°C to 35°C (50°F to 95°F) with no direct sunlight on the equipment.
Fresh air	For information about fresh air, see the Expanded Operating Temperature section.
Maximum temperature gradient (operating and storage)	20°C/h (68°F/h)

Table 8. Relative humidity specifications

Relative humidity	Specifications
Storage	5% to 95% RH with 33°C (91°F) maximum dew point. Atmosphere must be non-condensing at all times.
Operating	10% to 80% relative humidity with 29°C (84.2°F) maximum dew point.

Table 9. Maximum vibration specifications

Maximum vibration	Specifications
Operating	0.26 G _{rms} at 5 Hz to 350 Hz (all operation orientations).
Storage	1.88 G _{rms} at 10 Hz to 500 Hz for 15 min (all six sides tested).

Table 10. Maximum shock specifications

Maximum shock	Specifications
Operating	Six consecutively executed shock pulses in the positive and negative x, y, and z axes of 6 G for up to 11 ms.
Storage	Six consecutively executed shock pulses in the positive and negative x, y, and z axes (one pulse on each side of the system) of 71 G for up to 2 ms.

Table 11. Maximum altitude specifications

Maximum altitude	Specifications
Operating	3048 m (10,000 ft)
Storage	12,000 m (39,370 ft)

Table 12. Operating temperature derating specifications

Operating temperature derating	Specifications
Up to 35°C (95°F)	Maximum temperature is reduced by 1°C/300 m (1°F/547 ft) above 950 m (3,117 ft).
35°C to 40°C (95°F to 104°F)	Maximum temperature is reduced by 1°C/175 m (1°F/319 ft) above 950 m (3,117 ft).
40°C to 45°C (104°F to 113°F)	Maximum temperature is reduced by 1°C/125 m (1°F/228 ft) above 950 m (3,117 ft).

Particulate and gaseous contamination specifications

The following table defines the limitations that help avoid any equipment damage or failure from particulates and gaseous contamination. If the levels of particulates or gaseous pollution exceed the specified limitations and result in equipment damage or failure, you may need to rectify the environmental conditions. Re-mediation of environmental conditions is the responsibility of the customer.

Table 13. Particulate contamination specifications

Particulate contamination	Specifications
Air filtration	<p>Data center air filtration as defined by ISO Class 8 per ISO 14644-1 with a 95% upper confidence limit.</p> <p>NOTE: This condition applies to data center environments only. Air filtration requirements do not apply to IT equipment designed to be used outside a data center, in environments such as an office or factory floor.</p> <p>NOTE: Air entering the data center must have MERV11 or MERV13 filtration.</p>
Conductive dust	<p>Air must be free of conductive dust, zinc whiskers, or other conductive particles.</p> <p>NOTE: This condition applies to data center and non-data center environments.</p>

Particulate contamination

Specifications

Corrosive dust

- Air must be free of corrosive dust.
- Residual dust present in the air must have a deliquescent point less than 60% relative humidity.

NOTE: This condition applies to data center and non-data center environments.

Table 14. Gaseous contamination specifications

Gaseous contamination

Specifications

Copper coupon corrosion rate

<300 Å/month per Class G1 as defined by ANSI/ISA71.04-1985.

Silver coupon corrosion rate

<200 Å/month as defined by AHSRAE TC9.9.

NOTE: Maximum corrosive contaminant levels measured at ≤50% relative humidity.

Standard operating temperature

Table 15. Standard operating temperature specifications

Standard operating temperature

Specifications

Continuous operation (for altitude less than 950 m or 3117 ft)

10°C to 35°C (50°F to 95°F) with no direct sunlight on the equipment.

Expanded operating temperature

Table 16. Expanded operating temperature specifications

Expanded operating temperature

Specifications

Continuous operation

5°C to 40°C at 5% to 85% RH with 29°C dew point.

NOTE: Outside the standard operating temperature (10°C to 40°C), the system can operate continuously in temperatures as low as 5°C and as high as 40°C.

For temperatures between 35°C and 40°C, de-rate maximum allowable temperature by 1°C per 175 m above 950 m (1°F per 319 ft).

≤ 1% of annual operating hours

–5°C to 45°C at 5% to 90% RH with 29°C dew point.

NOTE: Outside the standard operating temperature (10°C to 40°C), the system can operate down to –5°C or up to 45°C for a maximum of 1% of its annual operating hours.

For temperatures between 40°C and 45°C, de-rate maximum allowable temperature by 1°C per 125 m above 950 m (1°F per 228 ft).

NOTE: When operating in the expanded temperature range, system performance may be impacted.

NOTE: When operating in the expanded temperature range, ambient temperature warnings may be reported on the bezel's LCD panel and in the System Event Log.

Expanded operating temperature restrictions

- Do not perform a cold startup below 5°C.
- The operating temperature specified is for a maximum altitude of 3050 m (10,000 ft).
- Redundant power supply configuration is required.
- GPGPU card is not supported.
- Rear drive configuration is not supported.
- Non-Dell qualified peripheral cards and/or peripheral cards greater than 25 W are not supported.
- 180 W CPU is not supported.
- Cabled PSU is not supported.

Thermal restriction matrix

Table 17. Thermal restriction matrix for R7415

Storage configuration		Front	8 x 3.5 inch drive	12 x 3.5 inch drive		12 x 3.5 inch drive	24 x 2.5 inch drive	24 x 2.5 inch drive with NVMe
		Rear	NA	NA		2 x 3.5 inch drive	NA	NA
Fan type		Standard fan		Standard fan		High performance fan	Standard fan	High performance fan
CPU heat sink type		1.5U heat sink		1.5U heat sink		2U heat sink	1.5U heat sink	1.5U heat sink
Processor number	TDP (W)	Core count	Ambient = 35°C	Ambient = 35°C	Ambient = 35°C	Ambient = 35°C	Ambient = 35°C	Ambient = 30°C
AMD 7601	180 W	32	Yes	Yes	Yes	Yes	Yes	Yes
AMD 7551P	180 W	32	Yes	Yes	Yes	Yes	Yes	Yes
AMD 7451	180 W	24	Yes	Yes	Yes	Yes	Yes	Yes
AMD 7401P	155 W/170 W	24	Yes	Yes	Yes	Yes	Yes	Yes
AMD 7351P	155 W/170 W	16	Yes	Yes	Yes	Yes	Yes	Yes
AMD 7251	120 W	8	Yes	Yes	Yes	Yes	Yes	Yes
AMD 7281	155 W/170 W	16	Yes	Yes	Yes	Yes	Yes	Yes
AMD 7261	155 W/170 W	8	Yes	Yes	Yes	Yes	Yes	Yes

Other thermal restrictions

The list below are other thermal restrictions:

1 128GB LRDIMM only support up to 30°C ambient

① | NOTE: Maximum DIMM capacity of 128GB will be available on a later time.

2 Mellanox CX5 only support up to 35°C ambient with limited slots 1, 7, and 8

Documentation resources

This section provides information about the documentation resources for your system.

Table 18. Additional documentation resources for your system

Task	Document	Location
Setting up your system	For more information about installing and securing the system into a rack, see the rack documentation included with your rack solution.	Dell.com/poweredgemanuals
	For information about setting up and turning on the system, see the <i>Getting Started Guide</i> document that is shipped with your system.	Dell.com/poweredgemanuals
Configuring your system	For information about the iDRAC features, configuring and logging in to iDRAC, and managing your system remotely, see the Integrated Dell Remote Access Controller User's Guide.	Dell.com/idracmanuals
	For information about installing the operating system, see the operating system documentation.	Dell.com/operatingsystemmanuals
	For information about understanding Remote Access Controller Admin (RACADM) subcommands and supported RACADM interfaces, see the RACADM Command Line Reference Guide for iDRAC.	Dell.com/idracmanuals
	For information about updating drivers and firmware, see the Methods to download firmware and drivers section in this document.	To download drivers: Dell.com/support/drivers
Managing your system	For information about systems management software offered by Dell, see the Dell OpenManage Systems Management Overview Guide.	Dell.com/openmanagemanuals
	For information about setting up, using, and troubleshooting OpenManage, see the Dell OpenManage Server Administrator User's Guide.	Dell.com/openmanagemanuals
	For information about installing, using, and troubleshooting Dell OpenManage Essentials, see the Dell OpenManage Essentials User's Guide.	Dell.com/openmanagemanuals
	For information about installing and using Dell SupportAssist, see the Dell EMC SupportAssist Enterprise User's Guide.	Dell.com/serviceabilitytools
	For understanding the features of Dell Lifecycle Controller, see the Dell Lifecycle Controller User's Guide.	Dell.com/idracmanuals

Task	Document	Location
	For information about partner programs enterprise systems management, see the OpenManage Connections Enterprise Systems Management documents.	Dell.com/openmanagemanuals
Working with the Dell PowerEdge RAID controllers	For information about understanding the features of the Dell PowerEdge RAID controllers (PERC), Software RAID controllers, or BOSS card and deploying the cards, see the Storage controller documentation.	Dell.com/storagecontrollermanuals
Understanding event and error messages	For information about checking the event and error messages generated by the system firmware and agents that monitor system components, see the Dell Event and Error Messages Reference Guide.	Dell.com/openmanagemanuals > OpenManage software
Troubleshooting your system	For information about identifying and troubleshooting the PowerEdge server issues, see the Server Troubleshooting Guide.	Dell.com/poweredgemanuals

Getting help

Topics:

- [Contacting Dell](#)
- [Documentation feedback](#)
- [Accessing system information by using QRL](#)
- [Receiving automated support with SupportAssist](#)

Contacting Dell

Dell provides several online and telephone based support and service options. If you do not have an active internet connection, you can find contact information about your purchase invoice, packing slip, bill, or Dell product catalog. Availability varies by country and product, and some services may not be available in your area. To contact Dell for sales, technical assistance, or customer service issues:

- 1 Go to Dell.com/support.
- 2 Select your country from the drop-down menu on the lower right corner of the page.
- 3 For customized support:
 - a Enter your system Service Tag in the **Enter your Service Tag** field.
 - b Click **Submit**.The support page that lists the various support categories is displayed.
- 4 For general support:
 - a Select your product category.
 - b Select your product segment.
 - c Select your product.The support page that lists the various support categories is displayed.
- 5 For contact details of Dell Global Technical Support:
 - a Click [Global Technical Support](#).
 - b The **Contact Technical Support** page is displayed with details to call, chat, or e-mail the Dell Global Technical Support team.

Documentation feedback

You can rate the documentation or write your feedback on any of our Dell EMC documentation pages and click **Send Feedback** to send your feedback.

Accessing system information by using QRL

You can use the Quick Resource Locator (QRL) to get immediate access to the information about your system.

Prerequisites

Ensure that your smartphone or tablet has the QR code scanner installed.

The QRL includes the following information about your system:

- How-to videos
- Reference materials, including the Owner's Manual, LCD diagnostics, and mechanical overview

- Your system service tag to quickly access your specific hardware configuration and warranty information
- A direct link to Dell to contact technical assistance and sales teams

Steps

- 1 Go to **Dell.com/QRL** and navigate to your specific product or
- 2 Use your smartphone or tablet to scan the model-specific Quick Resource (QR) code on your Dell PowerEdge system or in the Quick Resource Locator section.

Quick Resource Locator for PowerEdge R7415



Figure 2. Quick Resource Locator for PowerEdge R7415

Receiving automated support with SupportAssist

Dell EMC SupportAssist is an optional Dell EMC EMC Services offering that automates technical support for your Dell EMC server, storage, and networking devices. By installing and setting up a SupportAssist application in your IT environment, you can receive the following benefits:

- **Automated issue detection** — SupportAssist monitors your Dell EMC devices and automatically detects hardware issues, both proactively and predictively.
- **Automated case creation** — When an issue is detected, SupportAssist automatically opens a support case with Dell EMC Technical Support.
- **Automated diagnostic collection** — SupportAssist automatically collects system state information from your devices and uploads it securely to Dell EMC. This information is used by Dell EMC Technical Support to troubleshoot the issue.
- **Proactive contact** — A Dell EMC Technical Support agent contacts you about the support case and helps you resolve the issue.

The available benefits vary depending on the Dell EMC Service entitlement purchased for your device. For more information about SupportAssist, go to Dell EMC.com/SupportAssist.