

System x3200 M3 Types 7327 and 7328

Installation and User's Guide

[Get Memory for M3 7327](#)

[Get Memory for M3 7328](#)

System x3200 M3 Types 7327 and 7328

Installation and User's Guide

Note:

Before using this information and the product it supports, read the general information in Appendix B, "Notices," on page 87 and the *IBM Safety Information*, and *IBM Environmental Notices and User's Guide* on the *IBM System x Documentation CD*, and the *Warranty Information* document that comes with the server.

30 Working inside the server with the power on	31
Handling static-sensitive devices	31
Removing the side cover	32
Removing the two-piece bezel	32
Installing a memory module	35
Unbuffered DIMMs (UDIMMs)	36
Registered DIMMs (RDIMMs)	37
Installing drives.	40
Installing a DVD drive	41
Installing an optional tape drive	43
Installing a hot-swap SAS or hot-swap SATA hard disk drive	44
IDs for hot-swap hard disk drives	47
Installing a simple-swap SATA hard disk drive	47
Power and signal cables for internal drives	49
Installing an adapter	50
Installing the ServeRAID-BR10il v2 SAS/SATA controller	52
Installing the IBM ServeRAID-MR10i SAS/SATA controller	53
Installing the IBM ServeRaid-MR-10is VAULT SAS/SATA controller	56
Installing the virtual media key	58
Installing a hot-swap power supply	58
Installing a security rope clip	61
Completing the installation.	62
Reinstalling the two-piece bezel.	62
Reinstalling the side cover.	62
Connecting the cables	64
Updating the server configuration	65
Updating the server configuration	65
Connecting external devices	66
Installing the server in a rack.	66
Chapter 3. Configuring the server	67
Using the Setup utility	68
Starting the Setup utility	68
Setup utility menu choices.	68
Passwords	72
Using the Boot Manager program	73
Starting the backup server firmware	74
Using the ServerGuide Setup and Installation CD	74
ServerGuide features	75

Avis de conformité à la réglementation d'Industrie Canada 90
Australia and New Zealand Class A statement 90
United Kingdom telecommunications safety requirement.
. 90
European Union EMC Directive conformance statement 91
Taiwanese Class A warning statement
. 91
Germany Electromagnetic Compatibility Directive
. 91
People's Republic of China Class A warning statement 92
Japanese Voluntary Control Council for Interference (VCCI) statement 92

iv	System x3200 M3 Types 7327 and 7328: Installation and User's Guide	
	Korean Class A warning statement 92
	Index 93

Safety

Before installing this product, read the Safety Information.

قبل تركيب هذا المنتج، يجب قراءة الملاحظات الأمنية

Antes de instalar este produto, leia as Informações de Segurança.

在安装本产品之前，请仔细阅读 **Safety Information**
(安全信息)。

安裝本產品之前，請先閱讀「安全資訊」。

Prije instalacije ovog produkta obavezno pročitajte Sigurnosne Upute.

Před instalací tohoto produktu si přečtete příručku bezpečnostních instrukcí.

Læs sikkerhedsforskrifterne, før du installerer dette produkt.

Lees voordat u dit product installeert eerst de veiligheidsvoorschriften.

Ennen kuin asennat tämän tuotteen, lue turvaohjeet kohdasta Safety Information.

Avant d'installer ce produit, lisez les consignes de sécurité.

Vor der Installation dieses Produkts die Sicherheitshinweise lesen.

Πριν εγκαταστήσετε το προϊόν αυτό, διαβάστε τις πληροφορίες ασφάλειας (safety information).

לפני שתתקינו מוצר זה, קראו את הוראות הבטיחות.

A termék telepítése előtt olvassa el a Biztonsági előírásokat!

Prima di installare questo prodotto, leggere le Informazioni sulla Sicurezza.

製品の設置の前に、安全情報をお読みください。

본 제품을 설치하기 전에 안전 정보를 읽으십시오.

Пред да се инсталира овој продукт, прочитајте информацијата за безбедност.

Les sikkerhetsinformasjonen (Safety Information) før du installerer dette produktet.

Przed zainstalowaniem tego produktu, należy zapoznać się z książką "Informacje dotyczące bezpieczeństwa" (Safety Information).

Antes de instalar este produto, leia as Informações sobre Segurança.

Перед установкой продукта прочтите инструкции по технике безопасности.

Pred inštaláciou tohto zariadenia si pečítajte Bezpečnostné predpisy.

Pred namestitvijo tega proizvoda preberite Varnostne informacije.

Antes de instalar este producto, lea la información de seguridad.

Läs säkerhetsinformationen innan du installerar den här produkten.

Important:

All caution and danger statements in this documentation begin with a number. This number is used to cross reference an English caution or danger statement with translated versions of the caution or danger statement in the *IBM Safety Information* book.

For example, if a caution statement begins with a number 1, translations for that caution statement appear in the *IBM Safety Information* book under statement 1.

Be sure to read all caution and danger statements in this documentation before performing the instructions. Read any additional safety information that comes with the blade server or optional device before you install the device.

Statement 1:



DANGER

Electrical current from power, telephone, and communication cables is hazardous.

To avoid a shock hazard:

- ∨ **Do not connect or disconnect any cables or perform installation, maintenance, or reconfiguration of this product during an electrical storm.**
- ∨ **Connect all power cords to a properly wired and grounded electrical outlet.**
- ∨ **Connect to properly wired outlets any equipment that will be attached to this product.**
- ∨ **When possible, use one hand only to connect or disconnect signal cables.**
- ∨ **Never turn on any equipment when there is evidence of fire, water, or structural damage.**
- ∨ **Disconnect the attached power cords, telecommunications systems, networks, and modems before you open the device covers, unless instructed otherwise in the installation and configuration procedures.**
- ∨ **Connect and disconnect cables as described in the following table when installing, moving, or opening covers on this product or attached devices.**

To Connect:

1. Turn everything OFF.
2. First, attach all cables to devices.
3. Attach signal cables to connectors.
4. Attach power cords to outlet.
5. Turn device ON.

To Disconnect:

1. Turn everything OFF.
2. First, remove power cords from outlet.
3. Remove signal cables from connectors.
4. Remove all cables from devices.

Safety

Statement 2:



CAUTION:

When replacing the lithium battery, use only IBM Part Number 33F8354 or an equivalent type battery recommended by the manufacturer. If your system has a module containing a lithium battery, replace it only with the same module type made by the same manufacturer. The battery contains lithium and can explode if not properly used, handled, or disposed of.

Do not:

- ∨ **Throw or immerse into water** ∨
- Heat to more than 100°C (212°F)** ∨
- Repair or disassemble**

Dispose of the battery as required by local ordinances or regulations.

Statement 3:



CAUTION:

When laser products (such as CD-ROMs, DVD drives, fiber optic devices, or transmitters) are installed, note the following:

- v Do not remove the covers. Removing the covers of the laser product could result in exposure to hazardous laser radiation. There are no serviceable parts inside the device.
- v Use of controls or adjustments or performance of procedures other than those specified herein might result in hazardous radiation exposure.



DANGER

Some laser products contain an embedded Class 3A or Class 3B laser diode. Note the following.

Laser radiation when open. Do not stare into the beam, do not view directly with optical instruments, and avoid direct exposure to the beam.



Class 1 Laser Product
Laser Klasse 1
Laser Klass 1
Luokan 1 Laserlaite
Appareil A Laser de Classe 1`

Statement 4:



≥ 18 kg (39.7 lb)



≥ 32 kg (70.5 lb)

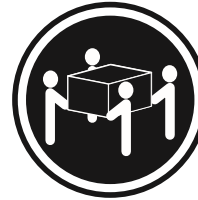

≥ 55 kg (121.2 lb)

CAUTION:

Use safe practices when lifting.

Statement 5:



CAUTION:

The power control button on the device and the power switch on the power supply do not turn off the electrical current supplied to the device. The device also might have more than one power cord. To remove all electrical current from the device, ensure that all power cords are disconnected from the power source.

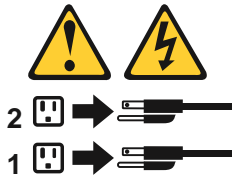

Statement 8:



CAUTION:

Never remove the cover on a power supply or any part that has the following label attached.



Hazardous voltage, current, and energy levels are present inside any component that has this label attached. There are no serviceable parts inside these components. If you suspect a problem with one of these parts, contact a service technician.

Statement 11:



CAUTION:

The following label indicates sharp edges, corners, or joints nearby.



Statement 12:



CAUTION:

The following label indicates a hot surface nearby.



Statement 13:



DANGER

Overloading a branch circuit is potentially a fire hazard and a shock hazard under certain conditions. To avoid these hazards, ensure that your system electrical requirements do not exceed branch circuit protection requirements. Refer to the information that is provided with your device for electrical specifications.

Statement 15:



CAUTION:

Make sure that the rack is secured properly to avoid tipping when the server unit is extended.

Statement 17:



CAUTION:

The following label indicates moving parts nearby.





CAUTION:

Do not place any object on top of rack-mounted devices.



This server is suitable for use on an IT power-distribution system whose maximum phase-to-phase voltage is 240 V under any distribution fault condition.

Statement 27:



CAUTION:

Hazardous moving parts are nearby.



Chapter 1. The System x3200 M3 server

This *Installation and User's Guide* contains information and instructions for setting up your IBM System x3200 M3 Types 7327 or 7328 server, instructions for installing optional devices, and instructions for cabling, and configuring the server. For removing and installing optional devices, diagnostics and troubleshooting information, see the *Problem Determination and Service Guide* on the IBM System x Documentation CD, which comes with the server.

The IBM® System x3200 M3 Types 7327 or 7328 server is a 5u-high-high, high-performance, self-contained server. It is ideally suited for networking environments that require superior microprocessor performance, improved systems management, and flexible memory and data management.

Performance, ease of use, reliability, and expansion capabilities were key considerations in the design of the server. These design features make it possible for you to customize the system hardware to meet your needs today and provide flexible expansion capabilities for the future.

The server comes with a limited warranty. For information about the terms of the warranty and getting service and assistance, see the *Warranty Information* document that comes with the server.

The server contains IBM Enterprise X-Architecture® technologies, which help increase performance, reliability, and availability. For more information, see “What your server offers” on page 10 and “Reliability, availability, and serviceability” on page 13.

You can obtain up-to-date information about the server and other IBM server products at <http://www.ibm.com/systems/x/>. At <http://www.ibm.com/support/mysupport/>, you can create a personalized support page by identifying IBM products that are of interest to you. From this personalized page, you can subscribe to weekly e-mail notifications about new technical documents, search for information and downloads, and access various administrative services.

If you participate in the IBM client reference program, you can share information about your use of technology, best practices, and innovative solutions; build a professional network; and gain visibility for your business. For more information about the IBM client reference program, see <http://www.ibm.com/ibm/clientreference/>.

Some server models support four 3.5-inch simple-swap SATA hard disk drives or four 3.5-inch hot-swap SAS or SATA hard disk drives. The illustrations in this document might differ slightly from your model.

The following illustration shows the simple-swap server model.

1. Racks are measured in vertical increments of 4.45 cm (1.75 inches) each. Each increment is called a "U." A 1u-high device is 1.75 inches tall.

© Copyright IBM Corp. 2010

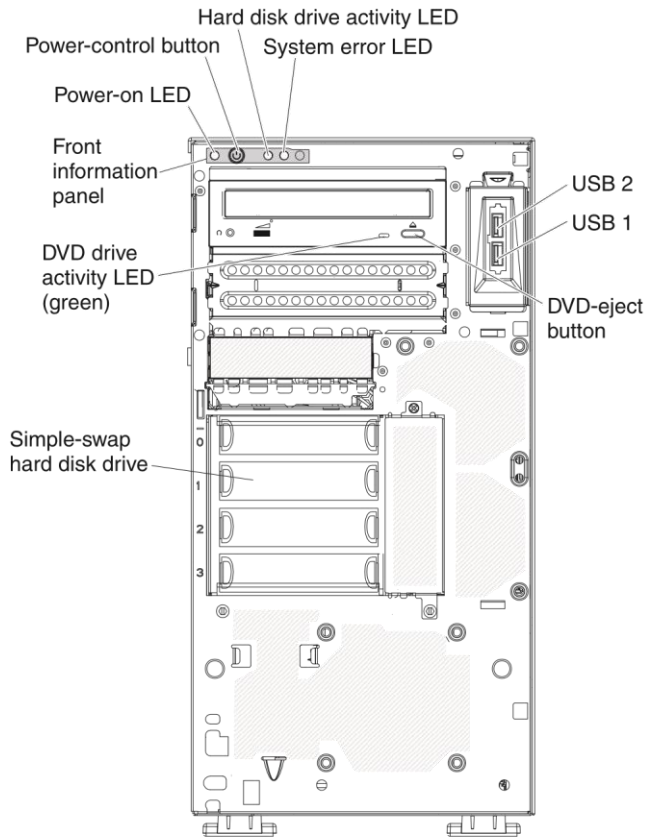

The following illustration shows the 3.5-inch hot-swap SAS or SATA server model.

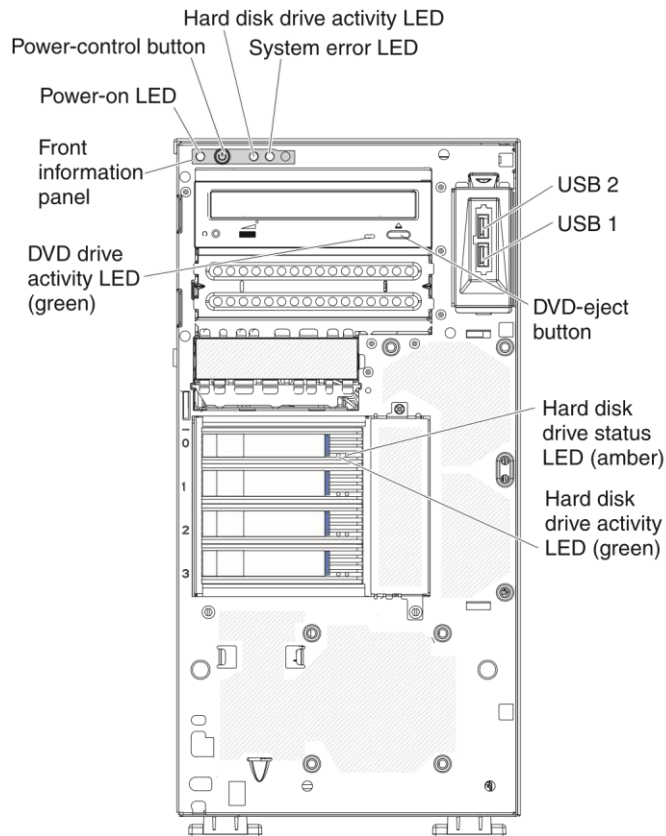

The following illustration shows the 2.5-inch hot-swap SAS or SATA server model.

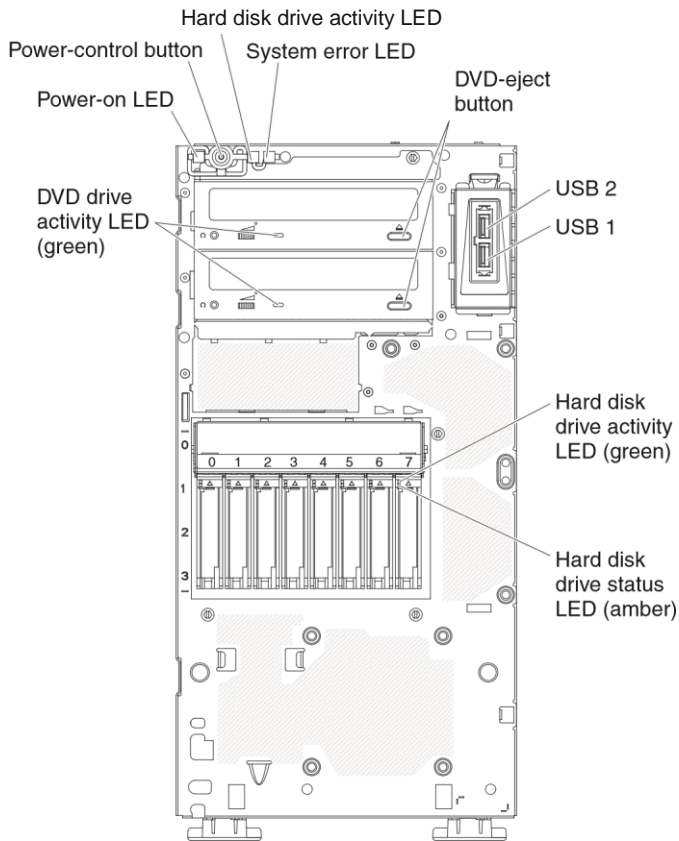

If firmware and documentation updates are available, you can download them from the IBM Web site. The server might have features that are not described in the documentation that comes with the server, and the documentation might be updated occasionally to include information about those features, or technical updates might be available to provide additional information that is not included in the server documentation. To check for updates, complete the following steps.

Note: Changes are made periodically to the IBM Web site. Procedures for locating firmware and documentation might vary slightly from what is described in this document.

1. Go to <http://www.ibm.com/systems/support/>.
2. Under **Product support**, click **System x**.
3. Under **Popular links**, click **Software and device drivers** for firmware updates, or click **Publications lookup** for documentation updates.

Record information about the server in the following table.

Product name	IBM System x3200 M3 server
Machine type	7327 or 7328
Model number	_____
Serial number	_____

The model number and serial number are on the lower-right side of the bezel, as shown in the following illustration.

Note: The illustrations in this document might differ slightly from your hardware.

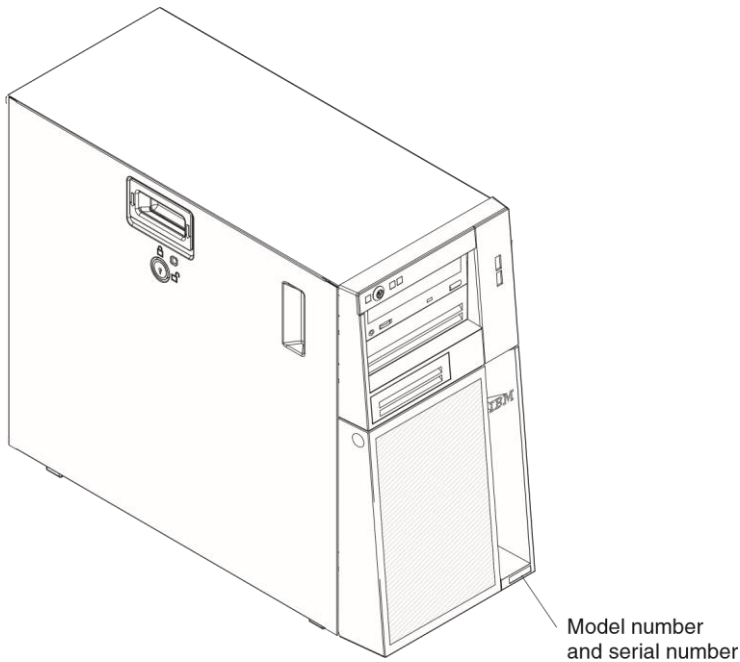

You can download an IBM *ServerGuide Setup and Installation* CD to help you configure the hardware, install device drivers, and install the operating system.

For a list of supported optional devices for the server, see <http://www.ibm.com/servers/eserver/serverproven/compat/us/>.

Important: The server keys cannot be duplicated by a locksmith. If you lose them, order replacement keys from the key manufacturer. The key serial number and the telephone number of the manufacturer are on a tag that is attached to the keys.

The server keys are in a plastic bag and attached to the front of the server chassis behind the lower-bezel door. To access the keys, remove the lower-bezel. The following illustration shows the location on the server where you can find the keys:

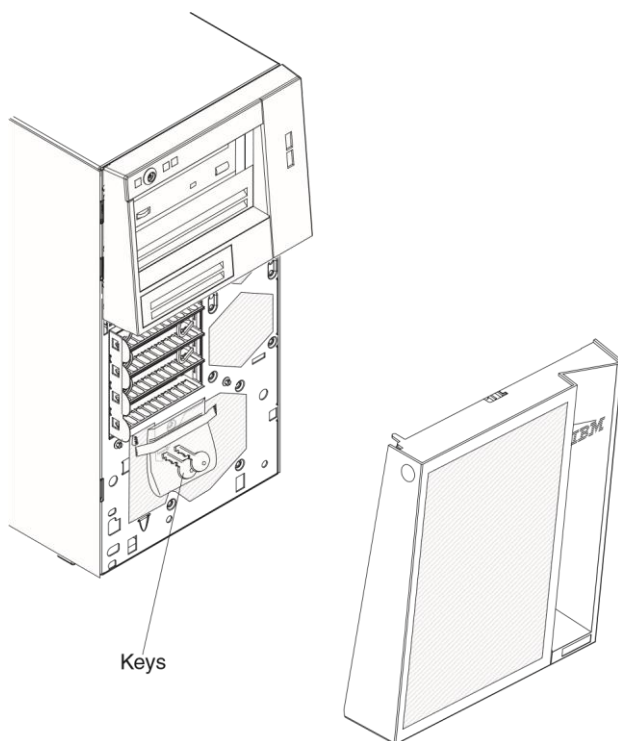

If you plan to install the server in a rack, you must purchase a Tower-to-Rack Kit. For a list of supported optional devices for the server, see <http://www-03.ibm.com/servers/eserver/serverproven/compat/us/>.

The IBM System x Documentation CD

The IBM *System x Documentation* CD contains documentation for the server in Portable Document Format (PDF) and includes the IBM Documentation Browser to help you find information quickly.

Hardware and software requirements

The IBM *System x Documentation* CD requires the following minimum hardware and software:

- √ Microsoft Windows XP, Windows 2000, or Red Hat Linux v
- 100 MHz microprocessor √ 32 MB of RAM
- √ Adobe Acrobat Reader 3.0 (or later) or xpdf, which comes with Linux operating systems

Using the Documentation Browser

Use the Documentation Browser to browse the contents of the CD, read brief descriptions of the documents, and view documents, using Adobe Acrobat Reader or xpdf. The Documentation Browser automatically detects the regional settings in use in your server and displays the documents in the language for that region (if available). If a document is not available in the language for that region, the English-language version is displayed.

Use one of the following procedures to start the Documentation Browser:

- v If Autostart is enabled, insert the CD into the CD or DVD drive. The Documentation Browser starts automatically.
- v If Autostart is disabled or is not enabled for all users, use one of the following procedures:
 - If you are using a Windows operating system, insert the CD into the CD or DVD drive and click **Start -> Run**. In the **Open** field, type
`e:\win32.bat`

where *e* is the drive letter of the CD or DVD drive, and click **OK**.
 - If you are using Red Hat Linux, insert the CD into the CD or DVD drive; then, run the following command from the `/mnt/cdrom` directory:
`sh runlinux.sh`

Select the server from the **Product** menu. The **Available Topics** list displays all the documents for the server. Some documents might be in folders. A plus sign (+) indicates each folder or document that has additional documents under it. Click the plus sign to display the additional documents.

When you select a document, a description of the document is displayed under **Topic Description**. To select more than one document, press and hold the Ctrl key while you select the documents. Click **View Book** to view the selected document or documents in Acrobat Reader or xpdf. If you selected more than one document, all the selected documents are opened in Acrobat Reader or xpdf.

To search all the documents, type a word or word string in the **Search** field and click **Search**. The documents in which the word or word string appears are listed in order of the most occurrences. Click a document to view it, and press Ctrl+F to use the Acrobat search function, or press Alt+F to use the xpdf search function within the document.

Click **Help** for detailed information about using the Documentation Browser.

Related documentation

This *Installation and User's Guide* contains general information about the server including how to set up and cabling the server, how to install supported optional devices, and how to configure the server. The following documentation also comes with the server:

- v *Warranty Information*

This printed document contains information about the terms of the warranty. v

- v *Environmental Notices and User Guide*

This document is in PDF format on the IBM *System x Documentation* CD. It contains translated environmental notices.

- v *Safety Information*

This document is in PDF on the IBM *System x Documentation* CD. It contains translated caution and danger statements. Each caution and danger statement that appears in the documentation has a number that you can use to locate the corresponding statement in your language in the *Safety Information* document. v
Problem Determination and Service Guide

This document is in PDF on the IBM *System x Documentation* CD. It contains information to help you solve problems yourself, and it contains information for service technicians.

Depending on the server model, additional documentation might be included on the IBM *System x Documentation* CD.

The xSeries and BladeCenter™ Tools Center is an online information center that contains information about tools for updating, managing, and deploying firmware, device drivers, and operating systems. The System x and xSeries Tools Center is at <http://publib.boulder.ibm.com/infocenter/toolsctr/v1r0/index.jsp>.

The server might have features that are not described in the documentation that you received with the server. The documentation might be updated occasionally to include information about those features, or technical updates might be available to provide additional information that is not included in the server documentation. These updates are available from the IBM Web site. To check for updated documentation and technical updates, complete the following steps.

Note: Changes are made periodically to the IBM Web site. The actual procedure might vary slightly from what is described in this document.

1. Go to <http://www.ibm.com/systems/support/>.
2. Under **Product support**, click **System x**.
3. Under **Popular links**, click **Publications lookup**.
4. From the **Product family** menu, select **System x3200 M3** and click **Continue**.

Notices and statements in this document

The caution and danger statements in this document are also in the multilingual *Safety Information* document, which is on the IBM *System x Documentation* CD. Each statement is numbered for reference to the corresponding statement in your language in the *Safety Information* document.

The following notices and statements are used in this document: v

Note: These notices provide important tips, guidance, or advice.

v **Important:** These notices provide information or advice that might help you avoid inconvenient or problem situations.

v **Attention:** These notices indicate potential damage to programs, devices, or data. An attention notice is placed just before the instruction or situation in which damage might occur.

v **Caution:** These statements indicate situations that can be potentially hazardous to you. A caution statement is placed just before the description of a potentially hazardous procedure step or situation.

v **Danger:** These statements indicate situations that can be potentially lethal or extremely hazardous to you. A danger statement is placed just before the description of a potentially lethal or extremely hazardous procedure step or situation.

Features and specifications

The following information is a summary of the features and specifications for Machine Type 7327 or 7328. Depending on the server model, some features might not be

available, or some specifications might not apply. See the *PDSG* on the *System x Documentation CD* for additional information about the server.

Table 1. Features and specifications

<p>Microprocessor:</p> <ul style="list-style-type: none"> √ Supports one Intel quad-core (Xeon 3400 series) or dual-core (Celeron G1101, Pentium G6950, or Core i3 series) processor the IbexPeak 3420 chip set and Multi-chip Package (MCP) processor architecture √ Designed for LGA 1156 socket √ Scalable up to four cores √ 32 KB instruction cache, 32 KB data cache, and up to 8 MB L3 cache that is shared among the cores √ Support for Intel Extended Memory 64 Technology (EM64T) <p>Note:</p> <ul style="list-style-type: none"> √ Use the Setup utility to determine the type and speed of the microprocessors. √ For a list of supported microprocessors, see http://www.ibm.com/servers/eserver/serverproven/compat/us/. <p>Memory:</p> <ul style="list-style-type: none"> √ Minimum: 1 GB √ Maximum: 32 GB <ul style="list-style-type: none"> – 16 GB using unbuffered DIMMs (UDIMMs) – 32 GB using registered DIMMs (RDIMMs) √ Types: PC3-8500 or PC3-10600 (single-rank or dual-rank), ECC unbuffered or registered double-data-rate 3 (DDR3) 1066 or 1333 MHz registered or unbuffered SDRAM DIMM √ Connectors: six dual inline memory module (DIMM) connectors, two-way interleaved √ Supports: <ul style="list-style-type: none"> – 1 GB, 2 GB, and 4 GB unbuffered DIMMs – 1 GB, 2 GB, 4 GB, and 8 GB registered DIMMs 	<p>Integrated functions:</p> <ul style="list-style-type: none"> √ Integrated management module (IMM), which provides service processor control and monitoring functions, video controller, and (when the optional virtual media key is installed) remote keyboard, video, mouse, and remote hard disk drive capabilities √ Intel 82574L Gb Ethernet controller √ Integrated Trusted Platform Module (TPM) support √ Integrated SATA controller (simple-swap and hot-swap models) √ Seven Universal Serial Bus (USB) 2.0 ports (two front and four rear of the chassis), one internal for the optional USB Hypervisor key. √ One serial port √ Two Ethernet ports √ One system-management RJ-45 on the rear to connect to a systems management network. This system management connector is shared to the IMM functions. This connector is active with or without the optional IBM Virtual Media Key installed. √ Six SATA II ports (four through the iPASS connector for simple-swap drives and two for the optical DVD and tape drives) 	<p>RAID controllers:</p> <ul style="list-style-type: none"> √ A ServeRAID-BR10i v2 SAS/SATA adapter that provides RAID levels 0, 1, and 1E (comes standard on some hot-swap SAS and hot-swap SATA models). √ An optional ServeRAID-MR10i SAS/SATA adapter that provides RAID levels 0, 1, 5, 6, and 10 can also be ordered. √ An optional ServeRAID-MR10is SAS/SATA adapter that provides RAID levels 0, 1, 5, 6, and 10 can also be ordered. <p>Environment:</p> <ul style="list-style-type: none"> √ Air temperature: <ul style="list-style-type: none"> – Server on: 10°C to 35°C (50°F to 95°F) – Altitude: 0 to 914.4 m (3000 ft) – Server on: 10°C to 32°C (50°F to 89.6°F) – Altitude: 914.4 m (3000 ft) to 2133.6 m (7000 ft) – Server off: 10°C to 43°C (50°F to 109.4°F) – Maximum altitude: 2133.6 m (7000.0 ft) – Shipping: -40°C to 60°C (-40°F to 140°F) √ Humidity (operating and storage): 8% to 80% √ Particulate contamination: <p>Attention: Airborne particulates and reactive gases acting alone or in combination with other environmental factors such as humidity or temperature might pose a risk to the server. For information about the limits for particulates and gases, see "Particulate contamination" on page 89.</p>
--	--	--

<p>Drives (depending on the model): v Diskette (optional): External or internal USB FDD drive and memory key v Hard disk drives: Hot-swap SAS, hot-swap SATA, or simple-swap SATA (support AHCI mode) v One of the following SATA attached optical drives: – DVD-ROM – Multiburner (optional)</p> <p>Drive bays (depending on the model): v Two 5.25 inch half-high bays (one optical drive installed). v One 3.5 inch slim-high removable-media drive bay (optional diskette drive) v Four 3.5 inch slim-high hard disk drive bays (some models) v Eight 2.5 inch slim-high hard disk drive bays (some models)</p>	<p>Fans: Three speed-controlled fixed fans</p> <p>Power supply: One of the following power supplies: v One or two redundant 430-watt (90-240 V ac) with Active Energy Manager v One non-redundant 401-watt (90-240 V ac) without Active Energy Manager</p> <p>Size: v Height: 438 mm (17.25 in.) v Depth: 540 mm (21.25 in.) v Width: 216 mm (8.5 in.) v Weight: 19.6 kg (43 lb) to 21.4 kg (47 lb) depending upon configuration</p>	<p>Heat output: Approximate heat output: v Minimum configuration: 188 Btu per hour (55 watts) v Maximum configuration: 1784 Btu per hour (523 watts)</p> <p>Electrical input: v Sine-wave input (50 or 60 Hz) required v Input voltage and frequency ranges automatically selected v Input voltage low range: – Minimum: 100 V ac – Maximum: 127 V ac v Input voltage high range: – Minimum: 200 V ac – Maximum: 240 V ac v Input kilovolt-amperes (kVA) approximately: – Minimum: 0.20 kVA (all models) – Maximum: 0.55 kVA</p>
--	---	---

Table 1. Features and specifications (continued)

<p>Up to six expansion slots (depending on the model): v Six expansion slots on the system board – Two PCI Express Gen2 x8 slots (x8 links) – One PCI Express Gen2 x4 slot (x4 link) – Two PCI 32-bit/33 MHz slots – One PCI Express Gen2 x4 slot (x4 electrical and mechanical) for the ServeRAID-BR10il v2 SAS/SATA adapter</p> <p>Video controller (integrated into IMM): v Matrox G200 video integrated on the system board – Compatible with SVGA and VGA</p> <p>Note: The maximum video resolution is 1280 x 1024 at 85 MHz</p>	<p>Acoustical noise emissions: v Sound power, idling: 5.0 bel v Sound power, operating: 5.3 bel</p>	<p>Notes:</p> <ol style="list-style-type: none"> 1. Power consumption and heat output vary depending on the number and type of optional features installed and the power-management optional features in use. 2. These levels were measured in controlled acoustical environments according to the procedures specified by the American National Standards Institute (ANSI) S12.10 and ISO 7779 and are reported in accordance with ISO 9296. Actual sound-pressure levels in a given location might exceed the average values stated because of room reflections and other nearby noise sources. The declared sound-power levels indicate an upper limit, below which a large number of computers will operate.
---	--	---

What your server offers

The server uses the following features and technologies:

v **Integrated management module**

The Integrated management module (IMM) combines service processor functions, video controller, and (when an optional virtual media key is installed) remote presence function in a single chip. The IMM provides advanced service-processor control, monitoring, and alerting function. If an environmental condition exceeds a threshold or if a system component fails, the IMM lights LEDs to help you diagnose the problem, records the error in the event log, and alerts you to the problem. Optionally, the IMM also provides a virtual presence capability for remote server management capabilities. The IMM provides remote server management through the following industry-standard interfaces:

- Intelligent Platform Management Interface (IPMI) version 2.0
- Simple Network Management Protocol (SNMP) version 3
- Common Information Model (CIM)
- Web browser

For additional information, see “Using the integrated management module” on page 76.

v **UEFI-compliant server firmware**

The IBM System x Server Firmware offers several features, including Unified Extensible Firmware Interface (UEFI) version 2.1 compliance, Active Energy Management (AEM) technology, enhanced reliability, availability, and serviceability (RAS) capabilities, and basic input/output system (BIOS) compatibility support. UEFI replaces the legacy BIOS. UEFI defines a standard interface between the operating system, platform firmware and external devices, and offers capabilities that far exceeds that of the legacy BIOS.

The server design combines the UEFI capabilities and features with legacy BIOS compatibility. The server is capable of booting UEFI-compliant operating systems, BIOS-based operating systems, and BIOS-based adapters as well as UEFI-compliant adapters.

Note: The server does not support DOS (Disk Operating System). v

IBM Dynamic System Analysis (DSA) Preboot Diagnostics CD

The IBM Dynamic System Analysis (DSA) Preboot Diagnostics CD contains the diagnostic program for testing the major components of the server. It collects and analyzes system information to aid in diagnosing server problems. The diagnostic programs collect the following information about the server:

- System configuration
- Network interfaces and settings
- Installed hardware
- Service processor status and configuration
- Vital product data, firmware, and UEFI configuration
- Hard disk drive health
- RAID controller configuration
- Event logs for ServeRAID controllers and service processors

The diagnostic programs create a merged log that includes events from all collected logs. The information is collected into a file that you can send to IBM service and

support. Additionally, you can view the information locally through a generated text report file. You can also copy the log to a removable media and view the log from a Web browser.

For additional information about DSA Preboot diagnostics, see the *Problem Determination and Service Guide* on the IBM System x Documentation CD v **Remote presence**

capability and blue-screen capture

The remote presence and blue-screen capture feature are integrated into the integrated management module (IMM). The virtual media key is required to enable the remote presence functions. When the optional virtual media key is installed in the server, it activates the remote presence functions. Without the virtual media key, you will not be able to access the network remotely to mount or unmount drives or images on the client system. However, you will still be able to access the Web interface without the virtual media key. You can order the optional IBM Virtual Media Key, if one did not come with your server. For more information about how to enable the remote presence function, see “Enabling the remote presence feature” on page 79.

v **High-performance graphics controller**

The server comes with an onboard high-performance graphics controller that supports high resolutions and includes many performance-enhancing features for the operating-system environment. v **IBM Systems Director CD**

IBM Systems Director is a workgroup-hardware-management tool that you can use to centrally manage System x and xSeries servers. For more information, see the IBM Systems Director documentation on the *IBM Systems Director CD* and “IBM Systems Director” on page 14.

v **IBM Enterprise X-Architecture technology**

IBM X-Architecture technology combines proven, innovative IBM designs to make your Intel-processor-based server powerful, scalable, and reliable. For more information, see <http://www.ibm.com/servers/eserver/xseries/xarchitecture/enterprise/index.html>.

v **IBM ServerGuide Setup and Installation CD**

The *ServerGuide Setup and Installation CD*, which you can download from the Web, provides programs to help you set up the server and install a Windows operating system. The ServerGuide program detects installed optional hardware devices and provides the correct configuration programs and device drivers. For more information about the *ServerGuide Setup and Installation CD*, see “Using the ServerGuide Setup and Installation CD” on page 74.

v **Active Energy Manager (AEM)**

The IBM Active Energy Manager solution is an IBM Systems Director plug-in that measures and reports server power consumption as it occurs. This enables you to monitor power consumption in correlation to specific software application programs and hardware configurations. You can obtain the measurement values through the systems-management interface and view them, using IBM Systems Director. For more information, including the required levels of IBM Systems Director and Active Energy Manager, see the IBM Systems Director documentation on the *IBM Systems Director CD*, or see <http://www.ibm.com/servers/systems/management/director/resources/>.

v **Integrated network support**

The server comes with an integrated dual-port Intel 82574L Gigabit Ethernet controller, which supports connection to a 10 Mbps, 100 Mbps, or 1000 Mbps network. For more information, see “Configuring the Gigabit Ethernet controller” on page 80.

v **Integrated Trusted Platform Module (TPM)**

This integrated security chip performs cryptographic functions and stores private and public secure keys. It provides the hardware support for the Trusted Computing Group (TCG) specification. You can download the software to support the TCG specification, when the software is available. See http://www.ibm.com/servers/eserver/xseries/scalable_family.html for details about the TPM implementation. You can enable TPM support through the Setup utility under the **System Security** menu choice. v **Large data-storage capacity and hot-swap capabilities**

Some hot-swap models support four 3.5-inch hot-swap SAS hard disk drives.

Some models support eight slim-high 2.5-inch hot-swap SAS hard disk drives. With the hot-swap feature, you can add, remove, or replace hard disk drives without turning off the server.

v **PCI adapter capabilities**

The server has two PCI interface slots on the riser card (one supports low-profile cards, and one supports full-height, three-quarter length cards). Both slots can support PCI Express or PCI-X adapters. See “Installing an adapter” on page 50 for detailed information.

v **Large system-memory capacity**

The server supports up to 32 GB of system memory when registered DIMMs are installed. The server supports up to 16 GB of memory when unbuffered DIMMs are installed. The memory controller supports error correcting code (ECC) and non-error correcting code for up to 6 industry-standard PC3-8500, or PC3-10600R-999 (single-rank or dual-rank), 1066 and 1333 MHz, DDR3 (third-generation double-data-rate), registered, and unbuffered synchronous dynamic random access memory (SDRAM) dual inline memory modules (DIMMs).

v **Redundant connection**

The addition of an optional network interface card (NIC) provides a failover capability to a redundant Ethernet connection. If a problem occurs with the primary Ethernet connection, all Ethernet traffic that is associated with the primary connection is automatically switched to the redundant NIC. If the applicable device drivers are installed, this switching occurs without data loss and without user intervention. v **ServeRAID support**

The ServeRAID adapter provides hardware redundant array of independent disks (RAID) support to create configurations. The standard RAID adapter provides RAID levels 0, 1, and 1E. The optional RAID adapters are available for purchase and provides RAID levels 0, 1, 5, 6, and 10. See “Installing an adapter” on page 50 and “Using LSI Configuration Utility program” on page 81 for more information about the adapters that are supported and creating RAID arrays.

v **Dual-core or quad-core processing**

The server supports one Intel Xeon dual-core or quad-core microprocessor. v **Systems-management**

capabilities

The server comes with an integrated management module (IMM). When the IMM is used with the systems-management software that comes with the server, you can manage the functions of the server locally and remotely. The IMM also provides system monitoring, event recording, and network alert capability. The system-management connector on the rear of the server is dedicated to the IMM. The dedicated system-management connector provides additional security by physically separating the management network traffic from the production network. You can use the Setup utility to configure the server to use a dedicated systems-management network or a shared network.

v **TCP/IP offload engine (TOE) support**

The Ethernet controller in the server support TOE, which is a technology that offloads the TCP/IP flow from the microprocessor and I/O subsystem to increase the speed of the TCP/IP flow. When an operating system that supports TOE is running on the server and TOE is enabled, the server supports TOE operation. See the operating-system documentation for information about enabling TOE. The Windows operating system requires that the Windows Scalable Network Pack (SNP) be installed for TOE support.

Note: As of the date of this document, the Linux operating system does not support TOE.

Reliability, availability, and serviceability

Three important server design features are reliability, availability, and serviceability (RAS). The RAS features help to ensure the integrity of the data that is stored in the

server, the availability of the server when you need it, and the ease with which you can diagnose and repair problems.

The server might have the following RAS features (the features vary depending on your model):

- √ 1-year parts and 1-year labor limited warranty (Machine Type 7327) and 3-year parts and 3-year labor limited warranty (Machine Type 7328)
- √ Advanced Configuration and Power Interface (ACPI) √ Advanced Desktop Management Interface (DMI) features √ Automatic BIOS recovery to a backup image √ Automatic error retry or recovery √ Automatic memory downsizing on error detection √ Automatic restart on nonmaskable interrupt (NMI) √ Automatic Server Restart (ASR) logic supporting a system restart when the operating system becomes unresponsive
- √ Automatic server restart after a power failure, based on the UEFI setting √ Availability of microcode level √ Boot-block recovery √ Built-in, menu-driven setup, system configuration, and redundant array of independent disks (RAID) configuration
- √ Built-in monitoring for fan, power, temperature, and voltage √ Cooling fans with speed-sensing capability √ Customer support center that is available 24 hours a day, 7 days a week¹ √ Diagnostic support of ServeRAID adapters √ Error codes and messages
- √ Error correcting code (ECC) double-data-rate 3 (DDR3) synchronous dynamic random-access memory (SDRAM) with serial presence detect (SPD)
- √ Error logging of POST failures
- √ Hot-swap Serial Attached SCSI (SAS) and hot-swap Serial ATA (SATA) hard disk drives
- √ Integrated Ethernet controller
- √ Intelligent Platform Management Interface (IPMI) √ Key-lock support for physical security
- √ Memory change messages posted to the error log √ Integrated management module (IMM) √ Power management √ Power-on self-test (POST) √ Read-only memory (ROM) checksums √ Redundant Ethernet capabilities (requires an optional Ethernet adapter) with failover support
- √ ROM-based diagnostic programs √ Simple-swap Serial Advanced Technology Attachment (SATA) hard disk drives √ Standby voltage for system-management features and monitoring √ System auto-configuring from the configuration menu √ System-error LED on the front bezel and diagnostic LEDs on the system board √ Upgradeable integrated management module (IMM) firmware
- √ Upgradeable microcode for POST, server firmware, and read-only memory (ROM) resident code, locally or over a LAN √ Vital product data (VPD); includes serial-number information and replacement

¹ . Service availability will vary by country. Response time varies; may exclude holidays.

part numbers, stored in nonvolatile memory, for easier remote maintenance v
Wake on LAN capability

IBM Systems Director

IBM Systems Director is a platform-management foundation that streamlines the way you manage physical and virtual systems supports multiple operating systems and virtualization technologies in IBM and non-IBM x86 platforms.

Through a single user interface, IBM Systems Director provides consistent views for viewing managed systems, determining how these systems relate to one other, and identifying their statuses, helping to correlate technical resources with business needs. A set of common tasks that are included with IBM Systems Director provides many of the core capabilities that are required for basic management, which means instant out-of-the-box business value. The following common tasks are included:

- v Discovery v
- Inventory v
- Configuration v
- System health v
- Monitoring v
- Updates
- v Event notification v Automation for managed systems

The IBM Systems Director Web and command-line interfaces provide a consistent interface that is focused on driving these common tasks and capabilities:

- v Discovering, navigating, and visualizing systems on the network with the detailed inventory and relationships to the other network resources
- v Notifying users of problems that occur on systems and the ability to isolate the sources of the problems
- v Notifying users when systems need updates and distributing and installing updates on a schedule
- v Analyzing real-time data for systems and setting critical thresholds that notify the administrator of emerging problems
- v Configuring settings of a single system and creating a configuration plan that can apply those settings to multiple systems
- v Updating installed plug-ins to add new features and functions to the base capabilities
- v Managing the life cycles of virtual resources

For more information about IBM Systems Director, see the documentation on the *IBM Systems Director* CD that comes with the server and the IBM xSeries Systems Management Web page at <http://www.ibm.com/systems/management/>, which presents an overview of IBM Systems Management and IBM Systems Director.

The UpdateXpress System Packs

The UpdateXpress System Packs provide an effective and simple way to update device drivers, server firmware, and firmware of supported options contained within the

server, for System x and IBM BladeCenter® servers. Each UpdateXpress System Pack contains all the online driver and firmware updates for a specific machine type and operating system combination. The UpdateXpress System Packs are released quarterly. Use the UpdateXpress System Pack Installer to install the current UpdateXpress System Pack for your server. You can download the installer and the latest UpdateXpress System Pack for your server from the Web at no additional cost. To download the installer or the latest UpdateXpress System Pack, go to <http://www.ibm.com/systems/support/supportsite.wss/docdisplay?Indocid=SERV-XPRESS&brandind=5000008> or complete the following steps.

Note: Changes are made periodically to the IBM Web site. The actual procedure might vary slightly from what is described in this document.

1. Go to <http://www.ibm.com/systems/support/>.
2. Under **Product support**, click **System x**.
3. Under **Popular links**, click **Software and device drivers**.
4. Under **Related downloads**, click **UpdateXpress**.

Server controls, LEDs, and power

This section describes the controls, light-emitting diodes (LEDs), and connectors on the front and rear of the server, and how to turn the server on and off. For the location of the LEDs on the system board, see “System-board LEDs” on page 29.

Note: The illustrations in this document might differ slightly from your model.

Front view

The following illustrations show the controls, LEDs, and connectors on the front of the server models.

The following is an illustration of the 3.5-inch SAS/SATA hot-swap hard disk drive model:

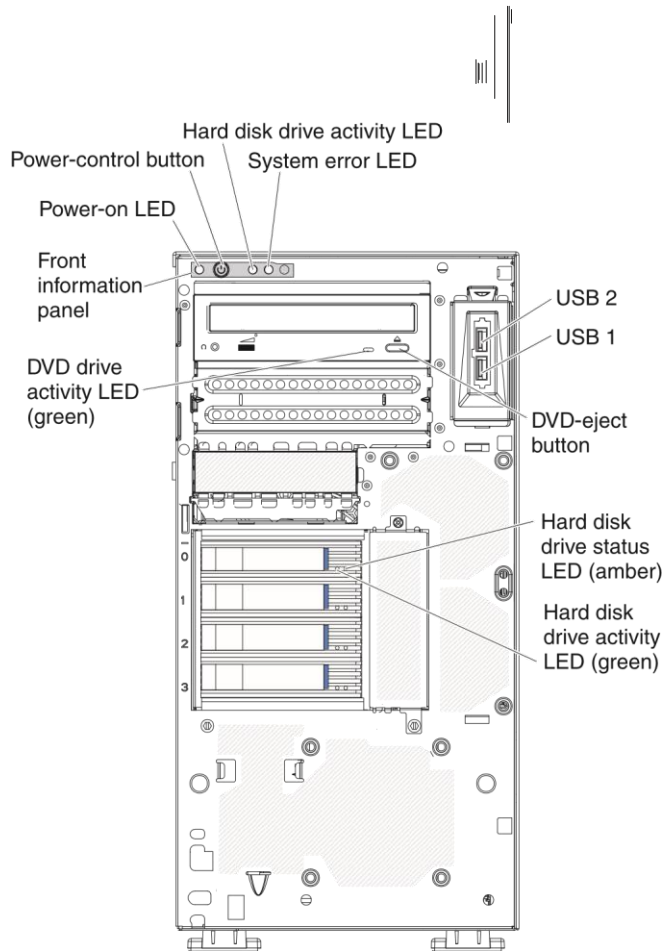

The following is an illustration of the 3.5-inch SATA simple-swap hard disk drive model:

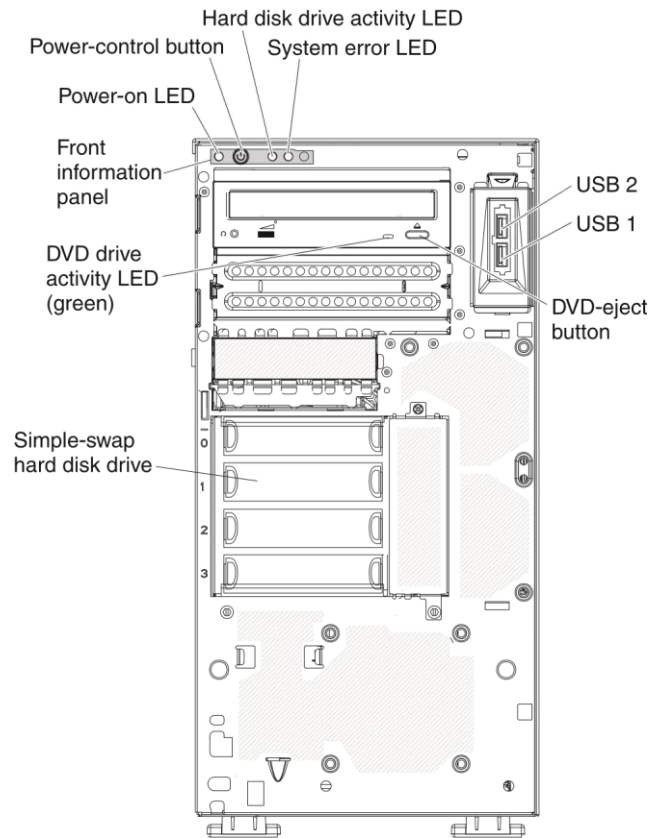

The following is an illustration of the 2.5-inch hot-swap SAS or SATA server model:

Hard disk drive activity LED

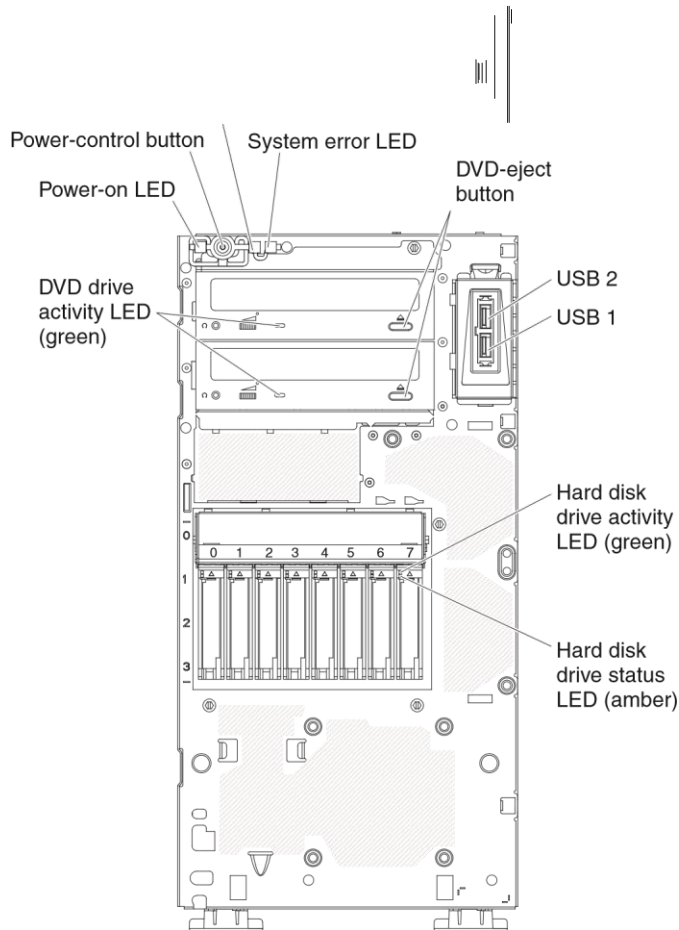

Power-control button and power-on LED

Press this button to turn the server on and off manually or to wake the server from a reduced-power state. The states of the power-on LED are as follows:

Off: AC power is not present, or the power supply or the LED itself has failed.

Flashing rapidly (4 times per second): The server is turned off and is not ready to be turned on. The power-control button is disabled. This will last approximately 1 to 3 minutes.

Flashing slowly (once per second): The server is turned off and is ready to be turned on. You can press the power-control button to turn on the server.

Lit: The server is turned on.

Fading on and off: The server is in a reduced-power state. To wake the server, press the power-control button or use the IMM Web interface. See “Logging on to the Web interface” on page 79 for information on logging on to the IMM Web interface.

Hard disk drive activity LED

When this LED is flashing rapidly, it indicates that
in use.



a hard disk drive is

System-error LED

When this amber LED is lit, it indicates that a system error has occurred. An
LED on the system board might also be lit to help isolate the error. Detailed
troubleshooting information is in the *Problem Determination and Service
Guide* on the IBM System x Documentation CD.

USB connectors

Connect USB devices to these connectors.

DVD-eject button

Press this button to release a CD or DVD from the DVD drive.

DVD drive activity LED

When this LED is lit, it indicates that the DVD drive is in use.

Hot-swap hard disk drive activity LED (some models)

On some server models, each hot-swap drive has a hard disk drive activity LED. When this green LED is flashing, it indicates that the associated hard disk drive is in use.

When the drive is removed, this LED also is visible on the SAS/SATA backplane, next to the drive connector. The backplane is the printed circuit board behind drive bays 4 through 7 (or bays 4 through 11 on some 2.5-inch hard disk drive SAS models).

Hot-swap hard disk drive status LED (some models)

On some server models, each hot-swap hard disk drive has an amber status LED. If this amber status LED is lit, it indicates that the associated hard disk drive has failed.

If an optional ServeRAID adapter is installed in the server and the LED flashes slowly (one flash per second), the drive is being rebuilt. If the LED flashes rapidly (three flashes per second), the adapter is identifying the drive.

When the drive is removed, this LED also is visible on the SAS/SATA backplane, below the hot-swap hard disk drive activity LED.

Rear view

The following illustration shows the LEDs and connectors on the rear of server models with hot-swap, redundant power supply.

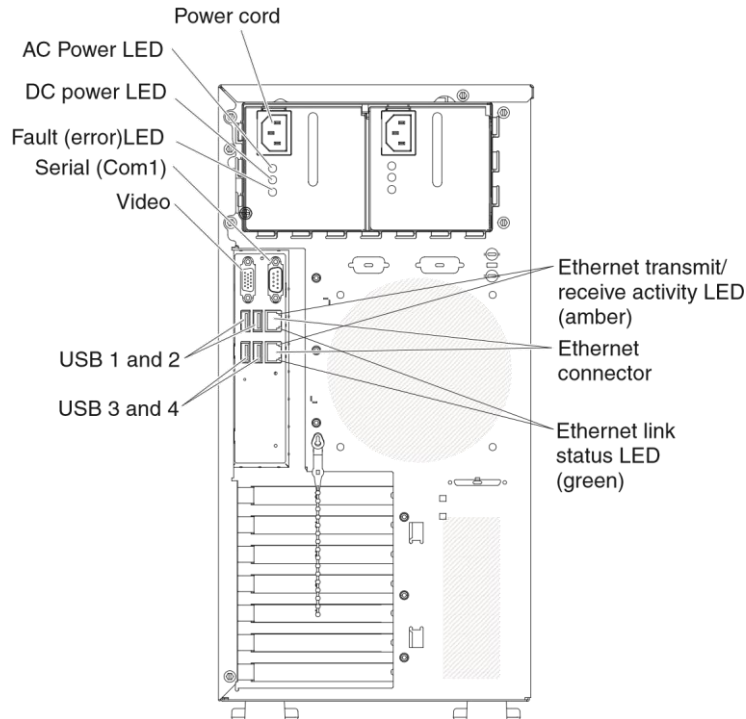

The following illustration shows the LEDs and connectors on the rear of server models with simple-swap, fixed power supply.

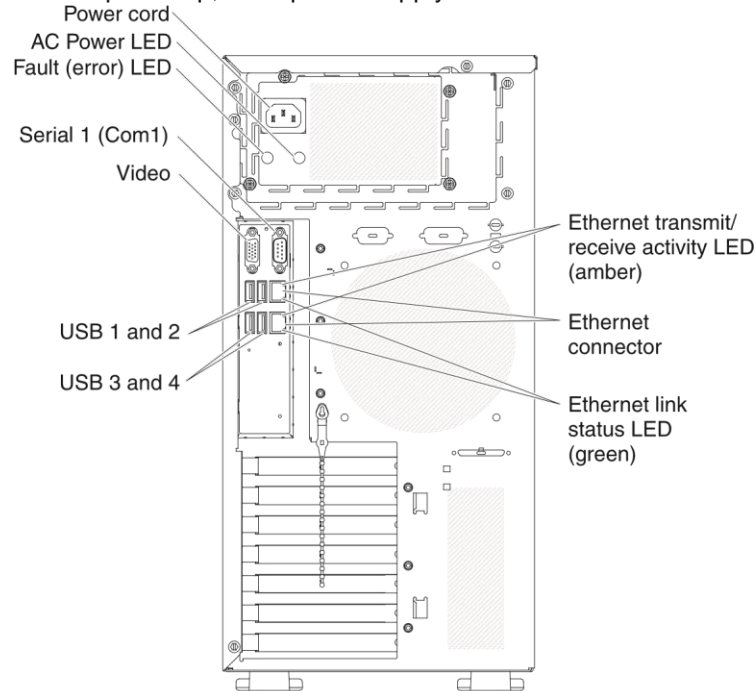

Power-cord connector

Connect the power cord to this connector.

AC power LED

This green LED provides status information about the power supply. During typical operation, both the ac and dc power LEDs are lit. For any other combination of LEDs, see the *Problem Determination and Service Guide* on the IBM System x Documentation CD.

DC power LED

This green LED provides status information about the power supply. During typical operation, both the ac and dc power LEDs are lit. For any other combination of LEDs, see the *Problem Determination and Service Guide* on the IBM System x Documentation CD.

Power-error (Fault) LED

When this amber LED is lit, it indicates that the power supply has failed. For any other combination of LEDs, see the *Problem Determination and Service Guide* on the IBM System x Documentation CD.

Video connector

Connect a monitor to this connector.

Note: The maximum video resolution is 1280 x 1024.

Serial connector

Connect a 9-pin serial device to this connector.

USB connectors

Connect USB devices to these connectors.

Ethernet connectors

Use either of these connectors to connect the server to a network. When you use the Ethernet 1 connector, the network can be shared with the IMM through a single network cable.

Ethernet transmit/receive activity LED

This LED is on the Ethernet connector on the rear of the server. When this LED is lit, it indicates that there is activity between the server and the network.

Ethernet link status LED

This LED is on the Ethernet connector on the rear of the server. When this LED is lit, it indicates that there is an active connection on the Ethernet port.

Server power features

When the server is connected to an ac power source but is not turned on, the operating system does not run, and all core logic except for the service processor (the integrated management module) is shut down; however, the server can respond to requests to the service processor, such as a remote request to turn on the server. The power-on LED flashes to indicate that the server is connected to ac power but is not turned on.

Turning on the server

Approximately 5 seconds after the server is connected to ac power, one or more fans might start running to provide cooling while the server is connected to power and the power-on button LED flashes quickly. Approximately 1 to 3 minutes after the server is connected to ac power, the power-control button becomes active (the power-on LED flashes slowly). You can turn on the server by pressing the power-control button.

The server can also be turned on in any of the following ways:

- √ If a power failure occurs while the server is turned on, the server will restart automatically when power is restored.
- √ If your operating system supports the Wake on LAN feature, the Wake on LAN feature can turn on the server.

Note: When 4 GB or more of memory (physical or logical) is installed, some memory is reserved for various system resources and is unavailable to the operating system. The amount of memory that is reserved for system resources depends on the operating system, the configuration of the server, and the configured peripheral component interconnect (PCI) devices.

Turning off the server

When you turn off the server and leave it connected to ac power, the server can respond to requests to the service processor, such as a remote request to turn on the server. While the server remains connected to ac power, one or more fans might continue to run. To remove all power from the server, you must disconnect it from the power source.

Some operating systems require an orderly shutdown before you turn off the server. See your operating-system documentation for information about shutting down the operating system.

Statement 5:



CAUTION:

The power control button on the device and the power switch on the power supply do not turn off the electrical current supplied to the device. The device also might have more than one power cord. To remove all electrical current from the device, ensure that all power cords are disconnected from the power source.



The server can be turned off in any of the following ways:

- √ You can turn off the server from the operating system, if your operating system supports this feature. After an orderly shutdown of the operating system, the server will be turned off automatically.
- √ You can press the power-control button to start an orderly shutdown of the operating system and turn off the server, if your operating system supports this feature.
- √ If the operating system stops functioning, you can press and hold the power-control button for more than 4 seconds to turn off the server. √ The server can be turned off by the Wake on LAN feature.
- √ The integrated management module (IMM) can turn off the server as an automatic response to a critical system failure.

Chapter 2. Installing optional devices

Important: Before you install optional hardware, make sure that the server is working correctly. Start the server, and make sure that the operating system starts, if an operating system is installed. If the server is not working correctly, see the *Problem Determination and Service Guide* for diagnostic information.

This chapter provides detailed instructions for installing optional hardware devices in the server.

Server components

The following illustration shows the major components in the server (depending on the server model). The illustrations in this document might differ slightly from your hardware.

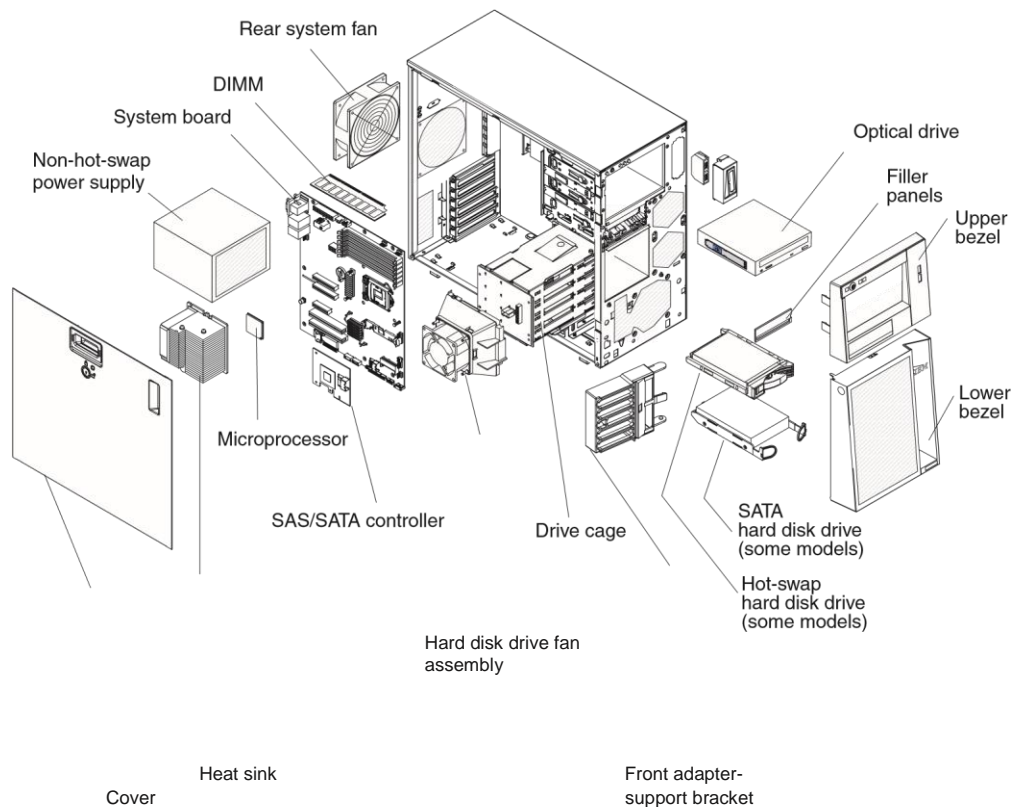

System-board internal connectors

The following illustration shows the internal connectors on the system board.

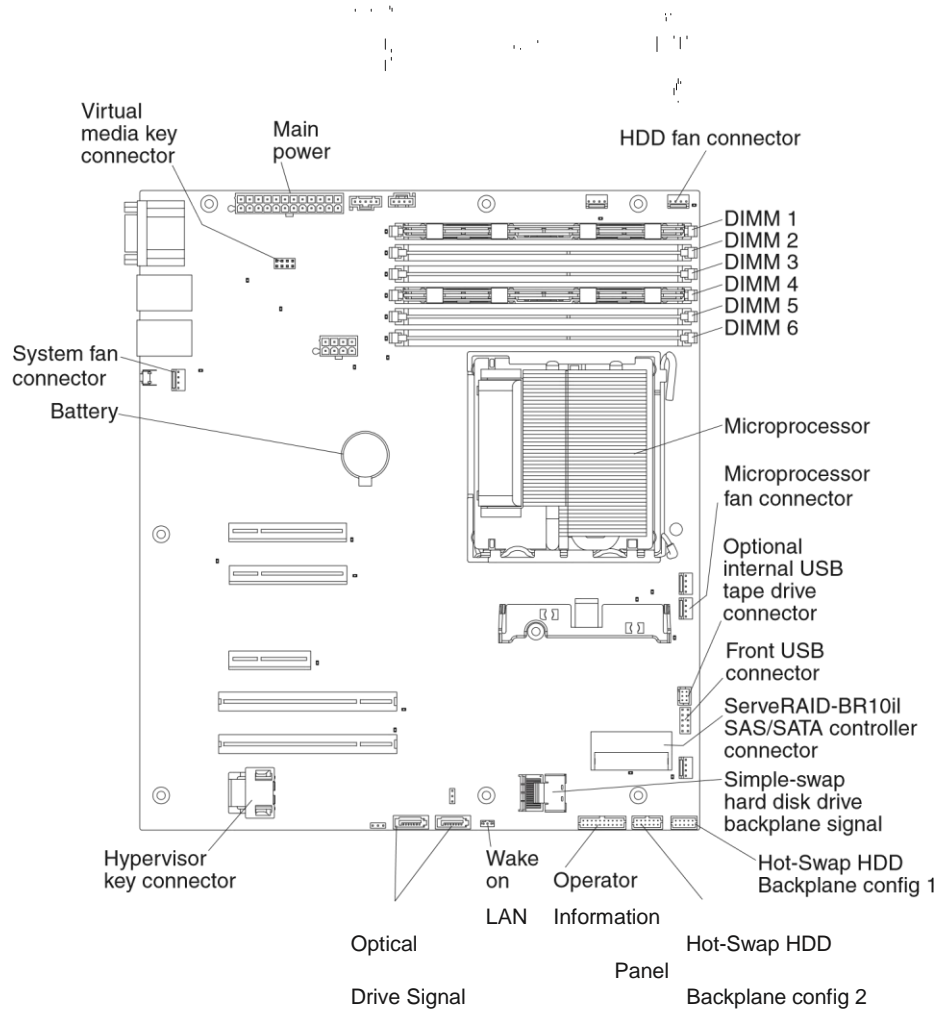

System-board optional-device connectors

The following illustration shows the system-board and connectors for user-installable optional devices.

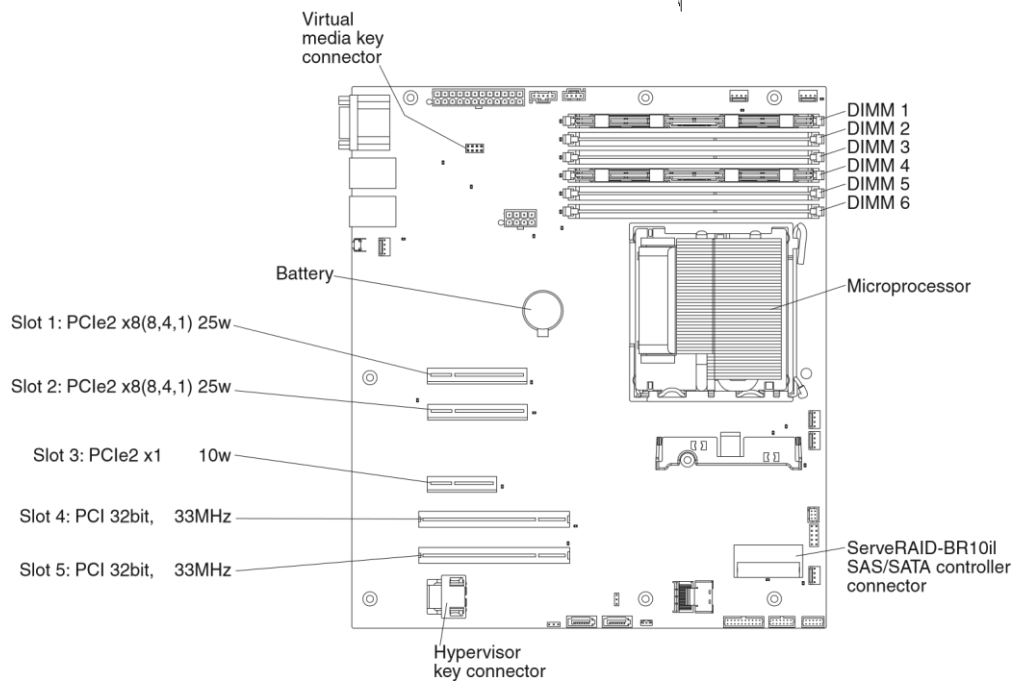

System-board switches and jumpers

The following illustration shows the switches and jumpers on the system board.

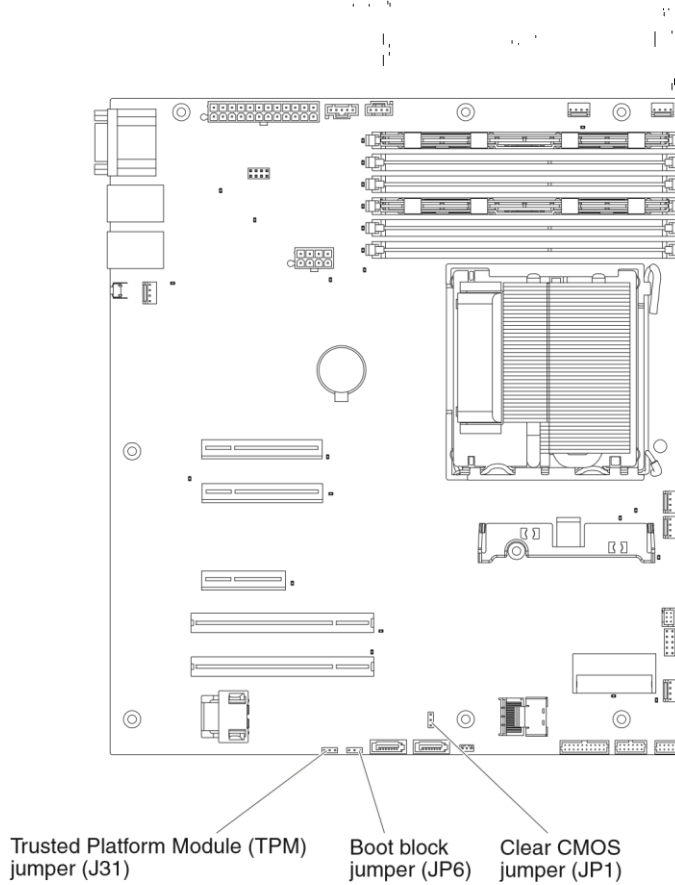

The following table describes the jumpers on the system board.

Table 2. System board jumpers

Jumper number	Jumper name	Jumper setting
JP1	Clear CMOS jumper	<ul style="list-style-type: none"> v Pins 1 and 2: Keep CMOS data (default). v Pins 2 and 3: Clear CMOS data (including power-on password).
JP6	Boot block jumper	<ul style="list-style-type: none"> v Pins 1 and 2: Boot from primary BIOS page (default). v Pins 2 and 3: Boot from backup BIOS page.

Table 2. System board jumpers (continued)

Jumper number	Jumper name	Jumper setting
J31	Trusted Platform Module (TPM) jumper	<p>Pins 1 and 2: Enable TPM physical presence. To enable TPM physical presence, complete the following steps:</p> <ol style="list-style-type: none"> 1. Turn off the server and remove all power cords and external cables. 2. Remove the jumper from JP6 and install it on J31 pins 1 and 2. Take note which pins the jumper is originally installed on JP6. 3. Turn on the server and access the Setup utility menu to verify that the TPM function has been activated (see "Using the Setup utility" on page 68). 4. Turn off the server and replace the jumper on JP6. 5. Turn on the server.
<p>Notes:</p> <ul style="list-style-type: none"> √ If no jumper is present, the server responds as if the pins are set to 1 and 2. √ Changing the position of the boot block jumper from pins 1 and 2 to pins 2 and 3 before the server is turned on alters which flash ROM page is loaded. Do not change the jumper pin position after the server is turned on. This can cause an unpredictable problem. 		

Important:

1. Before you change any switch settings or move any jumpers, turn off the server, then, disconnect all power cords and external cables. Review the information in "Installation guidelines" on page 29, "Handling static-sensitive devices" on page 31, and "Turning off the server" on page 22.
2. Any system-board switch blocks or jumpers that are not shown in the illustrations in this document are reserved.

System-board external connectors

The following illustration shows the external input/output (I/O) connectors on the system board.

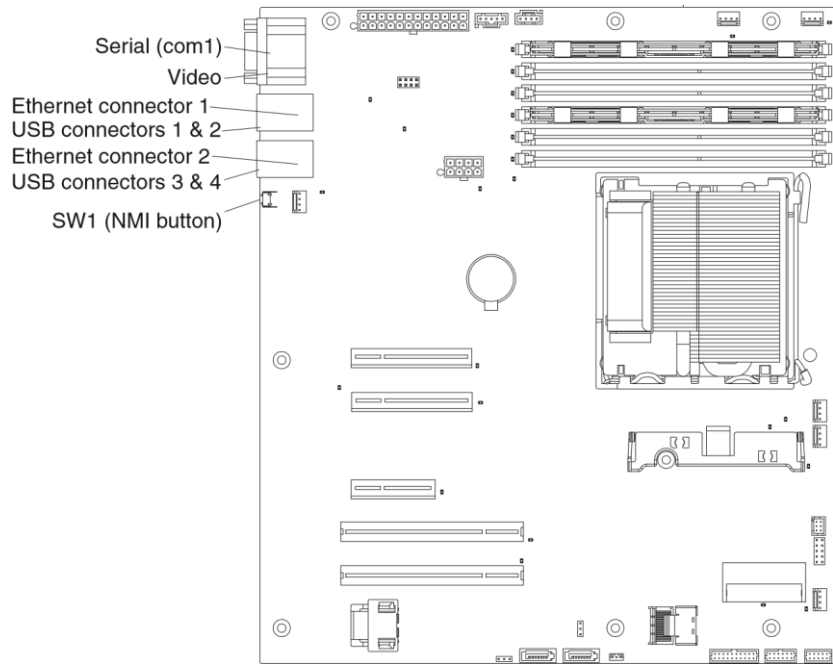

System-board LEDs

The following illustration shows the light-emitting diodes (LEDs) on the system board.

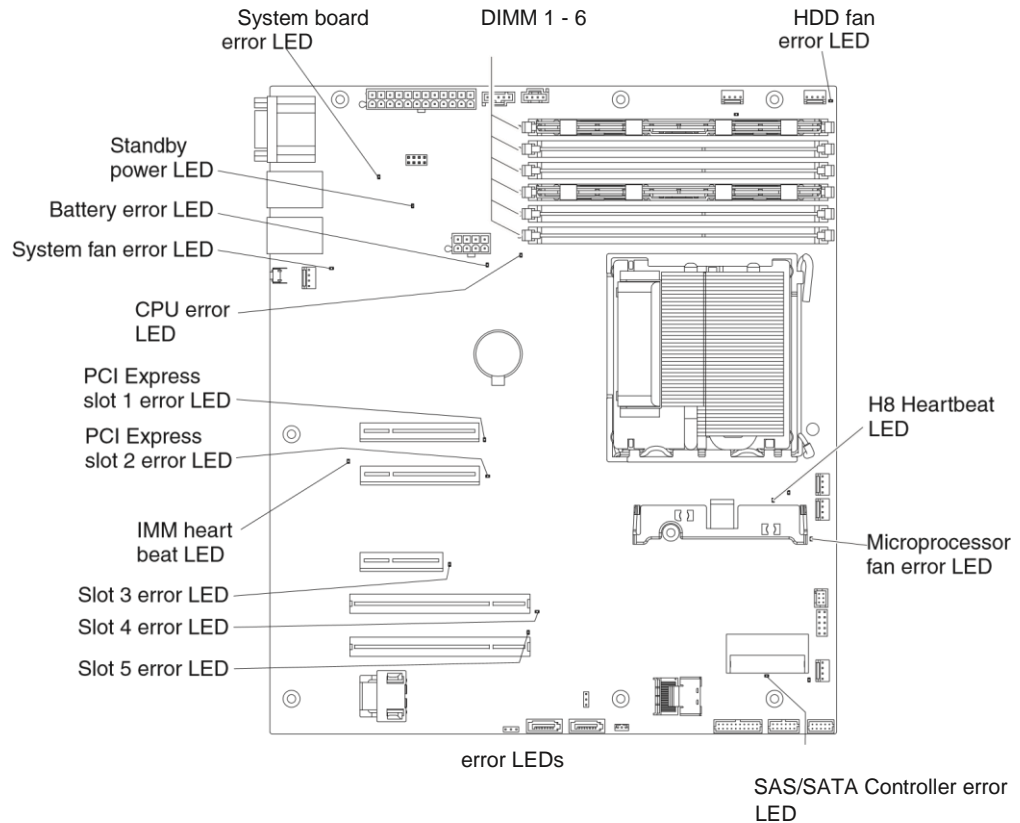

For more information about the system-board LEDs, see the *Problem Determination and Service Guide* on the IBM System x Documentation CD.

Installation guidelines

Before you install options, read the following information:

- v Read the safety information that begins on page vii, the guidelines in “Working inside the server with the power on” on page 31, and “Handling static-sensitive devices” on page 31. This information will help you work safely.
- v When you install your new server, take the opportunity to download and apply the most recent firmware updates. This step will help to ensure that any known issues are addressed and that your server is ready to function at maximum levels of performance. To download firmware updates for your server, complete the following steps:
 1. Go to <http://www.ibm.com/systems/support/>.
 2. Under **Product support**, click **System x**.
 3. Under **Popular links**, click **Software and device drivers**.
 4. Click **System x3200 M3** to display the matrix of downloadable files for the server.For additional information about tools for updating, managing, and deploying

firmware, see the System x and Blade Center Tools Center at <http://publib.boulder.ibm.com/infocenter/toolscctr/v1r0/index.jsp>.

- v Before you install optional hardware, make sure that the server is working correctly. Start the server, and make sure that the operating system starts, if an operating system is installed. If the server is not working correctly, see the *Problem Determination and Service Guide* for diagnostic information.
- v Observe good housekeeping in the area where you are working. Place removed covers and other parts in a safe place.
- v If you must start the server while the cover is removed, make sure that no one is near the server and that no tools or other objects have been left inside the server.
- v Do not attempt to lift an object that you think is too heavy for you. If you have to lift a heavy object, observe the following precautions:
 - Make sure that you can stand safely without slipping.
 - Distribute the weight of the object equally between your feet.
 - Use a slow lifting force. Never move suddenly or twist when you lift a heavy object.
 - To avoid straining the muscles in your back, lift by standing or by pushing up with your leg muscles.
- v Make sure that you have an adequate number of properly grounded electrical outlets for the server, monitor, and other devices. v Back up all important data before you make changes to disk drives.
- v Have a small flat-blade screwdriver, a small Phillips screwdriver, and a T8 torx screwdriver available.
- v You do not have to turn off the server to install or replace hot-swap fans and hot-swap drives.
- v Blue on a component indicates touch points, where you can grip the component to remove it from or install it in the server, open or close a latch, and so on.
- v Orange on a component or an orange label on or near a component indicates that the component can be hot-swapped, which means that if the server and operating system support hot-swap capability, you can remove or install the component while the server is running. (Orange can also indicate touch points on hot-swap components.) See the instructions for removing and installing a specific hot-swap component for any additional procedures that you might have to perform before you remove or install the component.
- v When you have to access the inside of the server, you might find it easier to lay the server on its side.
- v When you are finished working on the server, reinstall all safety shields, guards, labels, and ground wires.
- v For a list of supported options for the server, see <http://www.ibm.com/servers/eserver/serverproven/compat/us/>.

System reliability guidelines

To help ensure proper system cooling and system reliability, make sure that the following requirements are met:

- v Each of the drive bays has a drive or a filler panel and electromagnetic compatibility (EMC) shield installed in it.
- v There is adequate space around the server to allow the server cooling system to work properly. Leave approximately 50 mm (2.0 in.) of open space around the front and rear of the server. Do not place objects in front of the fans. For proper cooling and airflow, replace the server cover before turning on the server. Operating the server

for extended periods of time (more than 30 minutes) with the server cover removed might damage server components.

- √ You have followed the cabling instructions that come with optional adapters.
- √ You have replaced a failed fan within 48 hours.
- √ You have replaced a hot-swap fan within 30 seconds of removal.
- √ You have replaced a hot-swap drive within 2 minutes of removal.

Working inside the server with the power on

Attention: Static electricity that is released to internal server components when the server is powered on might cause the server to halt, which could result in the loss of data. To avoid this potential problem, always use an electrostatic-discharge wrist strap or other grounding system when working inside the server with the power on.

The server (some models) supports hot-swap devices and is designed to operate safely while it is turned on and the cover is removed. Follow these guidelines when you work inside a server that is turned on.

- √ Avoid wearing loose-fitting clothing on your forearms. Button long-sleeved shirts before working inside the server; do not wear cuff links while you are working inside the server.
- √ Do not allow your necktie or scarf to hang inside the server.
- √ Remove jewelry, such as bracelets, necklaces, rings, and loose-fitting wrist watches.
- √ Remove items from your shirt pocket, such as pens and pencils, that could fall into the server as you lean over it.
- √ Avoid dropping any metallic objects, such as paper clips, hairpins, and screws, into the server.

Handling static-sensitive devices

Attention: Static electricity can damage the server and other electronic devices. To avoid damage, keep static-sensitive devices in their static-protective packages until you are ready to install them.

To reduce the possibility of electrostatic discharge, observe the following precautions:

- √ Limit your movement. Movement can cause static electricity to build up around you.
- √ The use of a grounding system is recommended. For example, wear an electrostatic-discharge wrist strap, if one is available. Always use an electrostatic-discharge wrist strap or other grounding system when working inside the server with the power on.
- √ Handle the device carefully, holding it by its edges or its frame.
- √ Do not touch solder joints, pins, or exposed circuitry.
- √ Do not leave the device where others can handle and damage it.
- √ While the device is still in its static-protective package, touch it to an unpainted metal surface on the outside of the server for at least 2 seconds. This drains static electricity from the package and from your body.
- √ Remove the device from its package and install it directly into the server without setting down the device. If it is necessary to set down the device, put it back into its static-protective package. Do not place the device on the server cover or on a metal surface.
- √ Take additional care when handling devices during cold weather. Heating reduces indoor humidity and increases static electricity.

Removing the side cover

Important: Before you install optional hardware, make sure that the server is working correctly. Start the server, and make sure that the operating system starts, if an operating system is installed. If the server is not working correctly, see the *Problem Determination and Service Guide* for diagnostic information.

To remove the server side cover, complete the following steps.

Attention: Operating the server for more than 30 minutes with the side cover removed might damage server components. For proper cooling and airflow, replace the side cover before turning on the server.

1. Read the safety information that begins on page vii and “Installation guidelines” on page 29.
2. Turn off the server and all attached devices (see “Turning off the server” on page 22); then, disconnect all power cords and external cables.
3. Unlock the side cover; then, press the cover-release latch down (as shown in the illustration); then, remove the cover and set it aside.

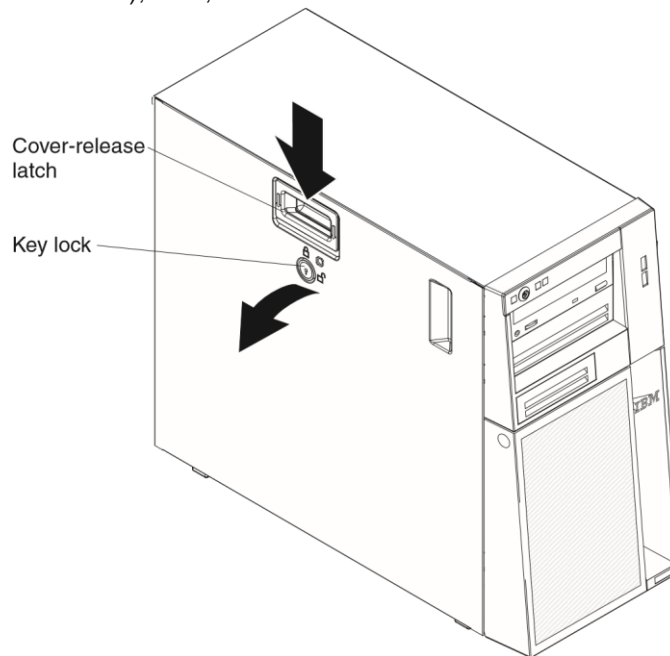

To replace the side cover, see “Reinstalling the side cover” on page 64.

Attention: For proper cooling and airflow, replace the cover before turning on the server. Operating the server for extended periods of time (more than 30 minutes) with the cover removed might damage server components.

Removing the two-piece bezel

When you work with some devices, such as drives in bays 1 through 7 (or bays 1 through 11 if you have the 2.5-inch eight-drive model, see page 40), you must first remove the two-piece bezel to access the devices.

Note:

- v Before you remove the upper bezel, you must unlock and remove the side cover and remove the lower bezel.
- v If you are removing only the lower bezel, you do not have to remove the side cover. However, the side cover must be unlocked.

To remove the two-piece bezel, complete the following steps:

1. Read the safety information that begins on page vii and “Installation guidelines” on page 29.
2. Unlock the side cover.
3. Remove the side cover (see “Removing the side cover” on page 32).
4. Press the round blue release button on the right side of the lower bezel and tilt the lower bezel forward to disengage it from the chassis.

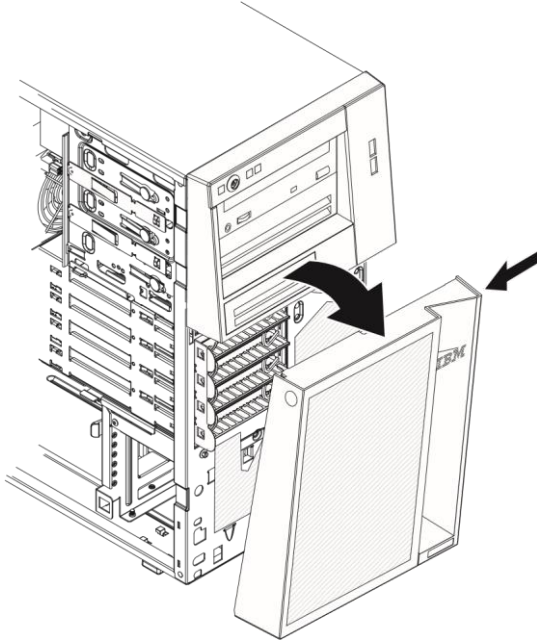

5. Lift the lower bezel to disengage the two bottom tabs from the chassis. Set the lower bezel aside.
6. Carefully pull the two bezel clips on the left side of the upper bezel away from the chassis; then, rotate the upper bezel to the right side of the server to disengage the two right-side tabs from the chassis. Set the upper bezel aside.

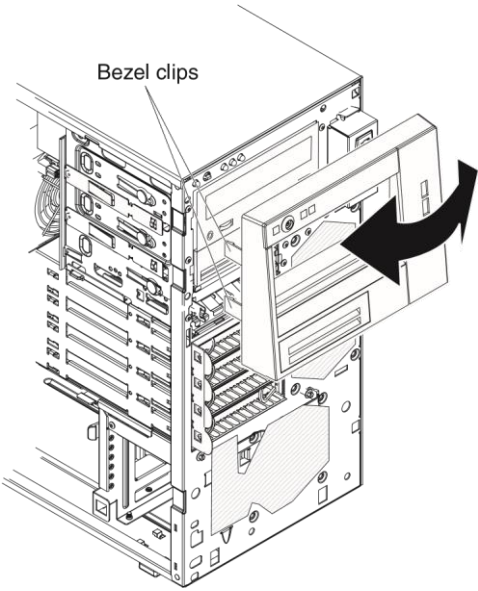

For instructions for replacing the two-piece bezel, see “Reinstalling the two-piece bezel” on page 62

Installing a memory module

The following notes describe the types of dual inline memory modules (DIMMs) that the server supports and other information that you must consider when you install DIMMs (see “System-board optional-device connectors” on page 25 for the location of the DIMM connectors):

- v The server supports only industry-standard double-data-rate 3 (DDR3), 1066 or 1333 MHz, PC3-8500 or PC3-10600 (single-rank, dual-rank, or quad-rank), registered or unbuffered, synchronous dynamic random-access memory (SDRAM) dual inline memory modules (DIMMs) with error correcting code (ECC). See <http://www.ibm.com/servers/eserver/serverproven/compat/us/> for a list of supported memory modules for the server.
- v The maximum amount of memory that the server supports is dependent on the type of memory that you install in the server. See “Unbuffered DIMMs (UDIMMs)” on page 36 and “Registered DIMMs (RDIMMs)” on page 37 for more information.
- v The amount of usable memory is reduced, depending on the system configuration. A certain amount of memory must be reserved for system resources. To view the total amount of installed memory and the amount of configured memory, run the Setup utility. For additional information, see “Using the Setup utility” on page 68.
- v The maximum operating speed of the server is determined by the slowest DIMM in the server.
- v If you install a pair of DIMMs in DIMM connectors 2 and 5, the size and speed of the DIMMs that you install in DIMM connectors 2 and 5 must match each other. However, they do not have to be the same size and speed as the DIMMs that are installed in DIMM connectors 1 and 4. v You can use compatible DIMMs from various manufacturers in the same pair.
- v When you install or remove DIMMs, the server configuration information changes. When you restart the server, the system displays a message that indicates that the memory configuration has changed.
- v The specifications of a DDR3 DIMM are on a label on the DIMM, in the following format. *ggg eRxff-PC3-wwwwwm-aa-bb-cc* where:
 - ggg* is the total capacity of the DIMM (for example, 1GB, 2GB, or 4GB) *e* is the number of ranks
 - 1 = single-rank
 - 2 = dual-rank
 - 4 = quad-rank
 - ff* is the device organization (bit width)
 - 4 = x4 organization (4 DQ lines per SDRAM)
 - 8 = x8 organization
 - 16 = x16 organization
 - wwwww* is the DIMM bandwidth, in MBps
 - 8500 = 8.53 GBps (PC3-1066 SDRAMs, 8-byte primary data bus)
 - 10600 = 10.66 GBps (PC3-1333 SDRAMs, 8-byte primary data bus)
 - m* is the DIMM type
 - E = Unbuffered DIMM (UDIMM) with ECC (x72-bit module data bus)
 - R = Registered DIMM (RDIMM)

U = Unbuffered DIMM with no ECC (x64-bit primary data bus) *aa* is the CAS latency, in clocks at maximum operating frequency *bb* is the JEDEC SPD Revision Encoding and Additions level *cc* is the reference design file for the design of the DIMM *d* is the revision number of the reference design of the DIMM

Note: To determine the type of a DIMM, see the label on the DIMM. The information on the label is in the format xxxxx nRxxx PC3-xxxxx-xx-xx-xxx. The numeral in the sixth numerical position indicates whether the DIMM is single-rank (n=1) or dual-rank (n=2).

The following sections provide additional information specific to unbuffered and registered DIMMs that you must consider.

Unbuffered DIMMs (UDIMMs)

The following notes provide information that you must consider when you install UDIMMs:

- √ The memory channels run at the fastest common frequency of the installed DIMMs.
- √ Do not use both UDIMMs and RDIMMs in the same server.
- √ Using ECC and non-ECC UDIMMs in the server will cause the server to run in non-ECC mode.
- √ The UDIMM options that are available for the server are 1 GB, 2 GB, and 4 GB (when available) memory DIMMs.
- √ You can install a maximum of 16 GB of memory in some server models when you use UDIMMs. √ The server supports up to two single-rank or dual-rank UDIMMs per channel.
- √ DIMM slots 3 and 6 are not supported when you install UDIMMs in the server. Do not install DIMMs in these connectors. √ The following table lists the DIMM support compatibility.

Table 3. Supported DIMM compatibility

DIMM configuration	Intel quad-core (Xeon 3400 series)	Intel dual-core (Core i3)	Intel dual-core (Xeon L3406)
UDIMM non-ECC only	Not supported	Not supported	Not supported
UDIMM ECC only	Supported	Supported	Supported
UDIMM mix ECC with non-ECC	Not supported	Not supported	Not supported
RDIMM ECC only	Supported	Not supported	Not supported

√ The following table lists the supported UDIMM population.

Table 4. Supported UDIMM population per channel

DIMMs slots per channel	DIMMs installed in each channel	DIMM type	DIMM speed	Ranks per DIMM (any combination)

2	1	Unbuffered DDR3 ECC	1066, 1333	single-rank, dual-rank
2	2	Unbuffered DDR3 ECC	1066, 1333	single-rank, dual-rank

√ The following table lists the maximum DIMM population using ranked UDIMM. *Table 5. Maximum memory population using ranked UDIMMs (depending on your model)*

Number of UDIMMs	DIMM type	DIMM size	Total memory
4	single-rank UDIMMs	1 GB	4 GB
4	single-rank UDIMMs	2 GB	8 GB
4	dual-rank UDIMMs	2 GB	8 GB
4	dual-rank UDIMMs	4 GB (when available)	16 GB

√ The following table lists the UDIMM memory population rule to optimize the system performance.

Table 6. UDIMMs population rule for dual-channel symmetric mode

DIMMs connector 1	DIMMs connector 2	DIMMs connector 3	DIMMs connector 4	DIMMs connector 5	DIMMs connector 6
populated	empty	empty	empty	empty	empty
populated	empty	empty	populated	empty	empty
populated	populated	empty	populated	populated	empty

Registered DIMMs (RDIMMs)

The following notes provide information that you must consider when you install RDIMMs:

- √ The memory channels run at the fastest common frequency of the installed DIMMs.
- √ Do not use both RDIMMs and UDIMMs in the same server.
- √ The server supports up to three single-rank, dual-rank, or quad-rank RDIMMs per channel.
- √ The RDIMM options that are available for the server are 1 GB, 2 GB, 4 GB, and 8 GB (when available) memory DIMMs.
- √ You can install a maximum of 32 GB of memory in the server when you use RDIMMs.
- √ The following table lists the supported RDIMM population.

Table 7. Supported RDIMM population per channel

DIMMs slots per channel	DIMMs installed in each channel	DIMM type	DIMM speed	Ranks per DIMM (any combination)
3	1	Registered DDR3 ECC	1066, 1333	single-rank, dual-rank
3	2	Registered DDR3 ECC	1066, 1333	single-rank, dual-rank
3	3	Registered DDR3 ECC	800	single-rank, dual-rank

3	1	Registered DDR3 ECC	1066	quad-rank
3	2	Registered DDR3 ECC	800	quad-rank

v The following table lists the maximum DIMM population using ranked RDIMM. *Table 8. Maximum memory population using ranked RDIMMs (depending on your model)*

Number of RDIMMs	DIMM type	DIMM size	Total memory
6	single-rank RDIMMs	1 GB	6 GB
6	single-rank RDIMMs	2 GB	12 GB
6	dual-rank RDIMMs	2 GB	12 GB
4	dual-rank RDIMMs	4 GB	16 GB
4	quad-rank RDIMMs	4 GB	16 GB
6	dual-rank RDIMMs	4 GB	24 GB
4	quad-rank RDIMMs	8 GB (when available)	32 GB

v The following table lists the RDIMM memory population rule to optimize the system performance.

Table 9. RDIMMs population rule for dual-channel symmetric mode

DIMMs connector 1	DIMMs connector 2	DIMMs connector 3	DIMMs connector 4	DIMMs connector 5	DIMMs connector 6
populated	empty	empty	empty	empty	empty
populated	empty	empty	populated	empty	empty
populated	populated	empty	populated	populated	empty
populated	populated	populated	populated	populated	populated

The following illustration shows the location of the DIMM connectors on the system board.

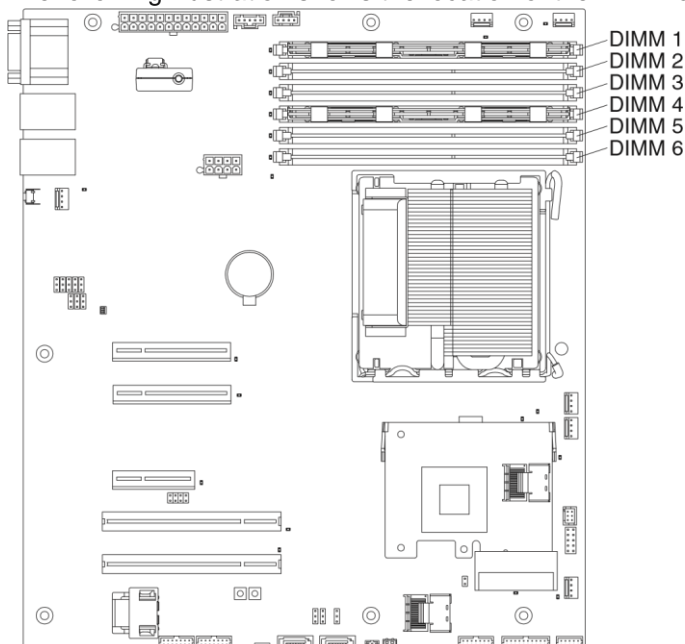

Attention: Static electricity that is released to internal server components when the server is powered-on might cause the server to stop, which could result in the loss of data. To avoid this potential problem, always use an electrostatic-discharge wrist strap or other grounding system when working inside the server with the power on.

To install a DIMM, complete the following steps:

1. Read the safety information that begins on page vii and “Installation guidelines” on page 29.
2. Turn off the server and peripheral devices and disconnect the power cords and all external cables, if necessary.
3. Remove the cover (see “Removing the side cover” on page 32).
4. Open the retaining clip on each end of the DIMM connector.

Attention: To avoid breaking the retaining clips or damaging the DIMM connectors, open and close the clips gently.

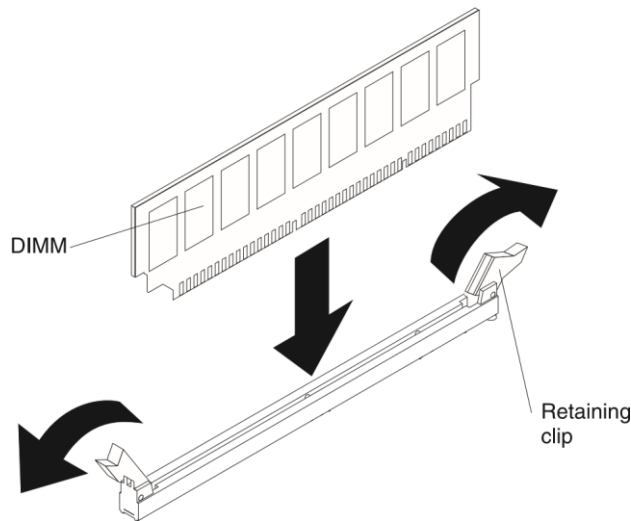

5. Touch the static-protective package that contains the DIMM to any unpainted metal surface on the outside of the server. Then, remove the DIMM from the package.
6. Turn the DIMM so that the DIMM keys align correctly with the connector.
7. Insert the DIMM into the connector by aligning the edges of the DIMM with the slots at the ends of the DIMM connector (see “System-board optional-device connectors” on page 25 for the location of the DIMM connectors).
8. Firmly press the DIMM straight down into the connector by applying pressure on both ends of the DIMM simultaneously. The retaining clips snap into the locked position when the DIMM is firmly seated in the connector.

Note: If there is a gap between the DIMM and the retaining clips, the DIMM has not been correctly inserted; open the retaining clips, remove the DIMM, and then reinsert it.

If you have other devices to install or remove, do so now; otherwise, go to “Completing the installation” on page 62.

Installing drives

Depending on the server model, a DVD-ROM or multiburner drive might be installed in the server. The server supports 2.5-inch or 3.5-inch hot-swap SAS, 3.5-inch hot-swap SATA, or 3.5-inch simple-swap SATA hard disk drives (depending on the model).

The following illustrations show the locations of the drive bays. Some models have seven drive bays, and some models have eleven drive bays.

Table 10. Drive bays on the server models

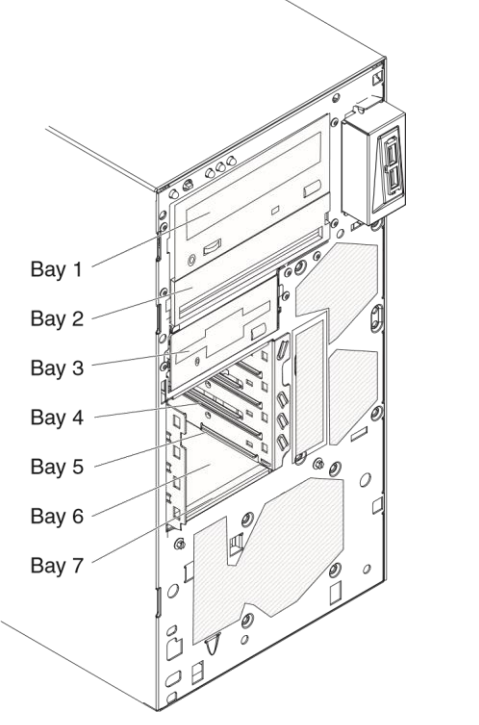
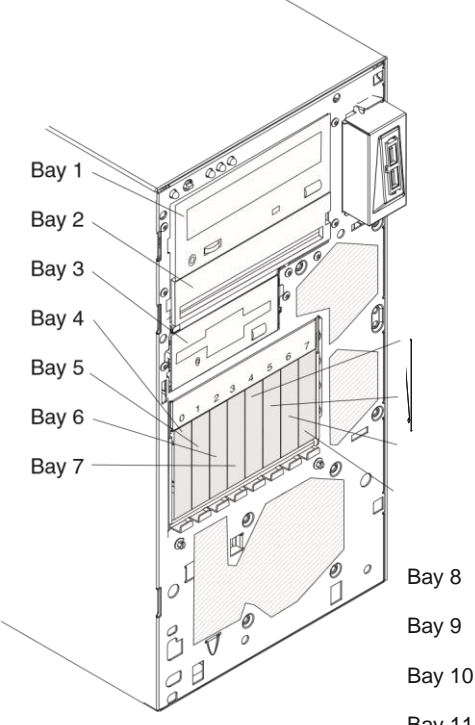
Seven drive bay model	Eleven drive bay model
	

The following notes describe the types of drives that the server supports and other information that you must consider when installing a drive:

- v Make sure that you have all the cables and other equipment that is specified in the documentation that comes with the drive.

v Select the bay in which you want to install the drive.
- v Check the instructions that come with the drive to see whether you have to set any switches or jumpers on the drive. If you are installing a SAS or SATA device, be sure to set the SAS or SATA ID for that device.
- v Optional internal or external USB diskette drives, tape drives, DVD-ROM, and multiburner drives are examples of removable-media drives. You can install removable-media drives in bays 1, 2, and 3 only.
- v The SATA removable-media drives that you install in bay 1 connects to the SATA 4 connector on the system board and the drive in bay 2 connects to the SATA 5 connector on the system board.
- v To install a 3.5-inch drive in a 5.25-inch bay, you must use the 5.25-inch conversion kit.

 - v The electromagnetic interference (EMI) integrity and cooling of the server are protected by having all bays and PCI and PCI Express slots covered or occupied. When you install a drive, PCI, or PCI Express adapter, save the EMC shield and filler panel from the bay or PCI or PCI Express adapter slot cover in the event that you later remove the device.
- v For a complete list of supported optional devices for the server, see <http://www.ibm.com/servers/eserver/serverproven/compat/us/>.

Installing a DVD drive

To install a DVD drive, complete the following steps:

1. Read the safety information that begins on page vii and “Installation guidelines” on page 29.
2. Turn off the server and peripheral devices, and disconnect the power cords and all external cables.
3. Unlock the side cover.
4. Remove the side cover (see “Removing the side cover” on page 32).
5. Remove the two-piece bezel (see “Removing the two-piece bezel” on page 32).
6. Use a screwdriver to pry the filler panel and EMC shield away from the server.

Note: If you are installing a drive that contains a laser, observe the following safety precaution. **Statement 3:**



CAUTION:

When laser products (such as CD-ROMs, DVD drives, fiber optic devices, or transmitters) are installed, note the following:

- v **Do not remove the covers. Removing the covers of the laser product could result in exposure to hazardous laser radiation. There are no serviceable parts inside the device.**
- v **Use of controls or adjustments or performance of procedures other than those specified herein might result in hazardous radiation exposure.**



DANGER

Some laser products contain an embedded Class 3A or Class 3B laser diode. Note the following.

Laser radiation when open. Do not stare into the beam, do not view directly with optical instruments, and avoid direct exposure to the beam.



Class 1 Laser Product
Laser Klasse 1
Laser Klass 1
Luokan 1 Laserlaite
Appareil A Laser de Classe 1`

7. Touch the static-protective package that contains the drive to any unpainted metal surface on the server; then, remove the drive from the package and place it on a static-protective surface.
8. Set any jumpers or switches on the drive according to the documentation that comes with the drive.

Note: You might find it easier to install the new drive from the front and then attach the cables.

9. Remove the drive retainer clip from the side of the drive cage of bay 1 or 2. Slide the drive retainer clip to the right to remove it from the drive cage; then, snap the drive retainer clip into the screw holes on the side of the drive.

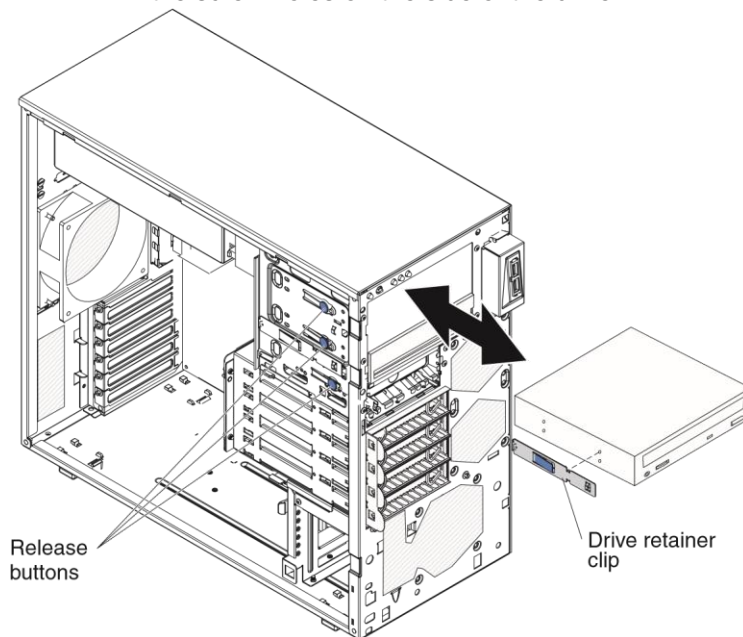

10. If you are installing a 5.2-inch drive in bay 2, slide the drive into the bay. If you are installing a 3.5-inch drive in bay 2, you must attach the 5.2-inch conversion kit to the 3.5-inch drive.

Note: An optional diskette drive can be installed in bay 3.

11. Connect one end of the applicable signal cable into the rear of the drive and make sure that the other end of this cable is connected into the applicable SATA connector on the system board.
12. Route the signal cable so that it does not block the airflow to the rear of the drives or over the microprocessor and dual inline memory modules (DIMMs).
13. If you have another drive to install or remove, do so now.
14. Connect the power cable to the rear of the drive. The connectors are keyed and can be inserted only one way.

If you have other devices to install or remove, do so now; otherwise, go to “Completing the installation” on page 62.

Installing an optional tape drive

To install an optional tape drive, complete the following steps.

1. Read the safety information that begins on page vii and “Installation guidelines” on page 29.
2. Turn off the server and peripheral devices, and disconnect the power cords and all external cables.
3. Unlock the side cover.
4. Remove the side cover (see “Removing the side cover” on page 32).
5. Remove the two-piece bezel (see “Removing the two-piece bezel” on page 32).

6. Use a screwdriver to pry the filler panel and EMC shield away from the server.
7. Touch the static-protective package that contains the drive to any unpainted metal surface on the server; then, remove the drive from the package and place it on a static-protective surface.
8. Set any jumpers or switches on the drive according to the documentation that comes with the drive.
9. Remove the drive retainer clip from the side of the drive cage of bay 1 or 2. Slide the drive retainer clip to the right to remove it from the drive cage; then, snap the drive retainer clip into the screw holes on the side of the drive.

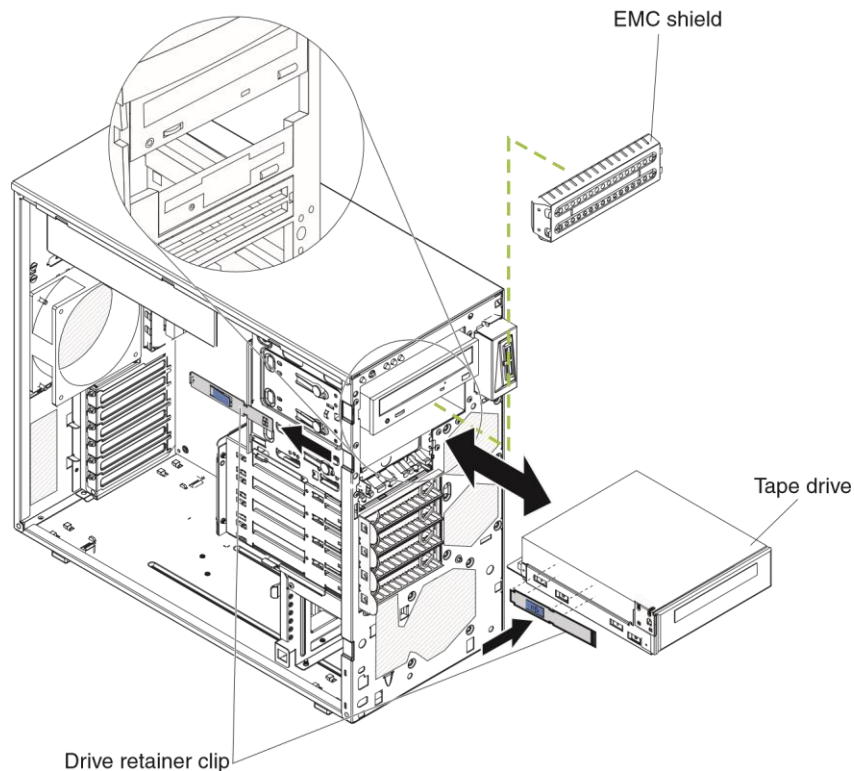

10. Slide the drive into the bay.

Note: A tape drive can be installed in bay 1 or 2.

11. Connect one end of the applicable signal cable into the rear of the drive and make sure that the other end of this cable is connected into the applicable connector on the system board.
12. Route the signal cable so that it does not block the airflow to the rear of the drives or over the microprocessor and dual inline memory modules (DIMMs).
13. If you have another drive to install or remove, do so now.
14. Connect the power cable to the rear of the drive. The connectors are keyed and can be inserted only one way.

If you have other devices to install or remove, do so now; otherwise go to “Completing the installation” on page 62.

Installing a hot-swap SAS or hot-swap SATA hard disk drive

Some hot-swap SAS models support 2.5-inch or 3.5-inch hot-swap SAS hard disk drives. The hot-swap SATA models support 3.5-inch hot-swap SATA hard disk drives. Before you install a hot-swap hard disk drive, read the following information:

- v The hot-swap drives must be either all SAS hard disk drives or all SATA hard disk drives; do not mix SAS and SATA drives in the server.
- v The hot-swap hard disk drive models come with the following drives (depending on your model):
 - Four 3.5-inch hot-swap SAS
 - Four 3.5-inch hot-swap SATA
 - Eight 2.5-inch hot-swap SAS
- v The sequence for installing the 3.5-inch hard disk drives in the four-bay models is to install the drives starting from the top bay (bay 4) and go to the bottom bay (bay 7) in that order. v Inspect the drive tray for signs of damage. v Make sure that the drive is correctly installed in the tray.
- v You do not have to turn off the server to install hot-swap drives in the hot-swap drive bays.
- v All hot-swap drives must have the same throughput speed rating; mixing speed ratings might cause all drives to operate at the lower throughput speed.
- v To maintain proper system cooling, do not operate the server for more than 10 minutes without either a drive or a filler panel installed in each drive bay.

The server hot-swap bays are connected to a SAS/SATA backplane. This backplane, also known as the hot-swap-drive backplane, is the printed circuit board behind these bays.

Attention: Static electricity that is released to internal server components when the server is powered-on might cause the server to stop, which could result in the loss of data. To avoid this potential problem, always use an electrostatic-discharge wrist strap or other grounding system when working inside the server with the power on.

To install a hot-swap hard disk drive, complete the following steps:

1. Read the safety information that begins on page vii and “Installation guidelines” on page 29.
2. Unlock the side cover (the bezel will not disengage from the server if the cover is locked).
3. Remove the lower bezel (see “Removing the two-piece bezel” on page 32).
4. Touch the static-protective package that contains the drive to any unpainted metal surface on the server; then, remove the drive from the package and place it on a static-protective surface.
5. Install the hard disk drive in the hot-swap bay:
 - a. Make sure that the drive tray handle is open.
 - b. Align the drive assembly with the guide rails in the bay as shown in the following illustrations based on your model.

Server model with four hot-swap drive bays	Server model with eight hot-swap drive bays
--	---

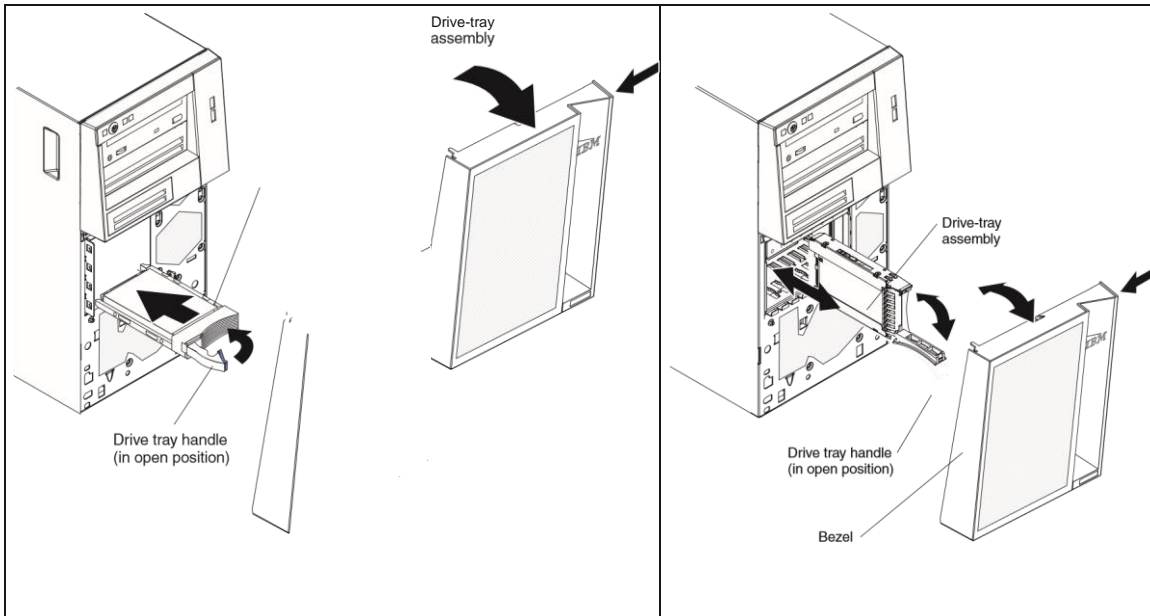

- c. Gently slide the drive assembly into the drive bay until the drive stops.
- d. Rotate the drive tray handle to the closed (locked) position.
- e. Check the hard disk drive status indicator to make sure that the hard disk drive is operating correctly. (You might have to restart the server before the drive is recognized.) If the amber hard disk drive status LED for a drive is lit continuously, it indicates that the drive is faulty and must be replaced. If the green hard disk drive activity LED is flashing, it indicates that the drive is being accessed.

Note: If the server is configured for RAID operation using an optional ServeRAID adapter, you might have to reconfigure your disk arrays after you install hard disk drives. See the ServeRAID documentation on the *IBM ServeRAID Support CD* for additional information about RAID operation and complete instructions for using ServeRAID Manager.

6. If you are installing additional hot-swap hard disk drives, do so now.

If you have other devices to install or remove, do so now; otherwise, go to “Completing the installation” on page 62.

IDs for hot-swap hard disk drives

On some models, the hot-swap-drive backplane controls the IDs of the internal hot-swap drive bays. The following table lists the IDs of the hard disk drives and backplane that are connected to one channel in the hot-swap models. In the typical configuration, the standard hard disk drives and backplane are connected to channel A. This table applies only to server models that support four hard disk drives.

Table 11. IDs of the hot-swap drives (models with four drive bays)

Drive bay	ID
4	0
5	1
6	2
7	3

If your server is the eight-bay, 2.5 inch hot-swap SAS model, the IDs of the hard disk drives are shown in the following table.

Table 12. IDs of the hot-swap drives (models with eight drive bays)

Drive bay	ID
4	0
5	1
6	2
7	3
8	4
9	5
10	6
11	7

Installing a simple-swap SATA hard disk drive

Some server models support 3.5-inch simple-swap SATA hard disk drives, which are accessible from the front of the server. You must disconnect all power from the server before you remove or install simple-swap drives. Before you install a simple-swap SATA hard disk drive, read the following information:

- v You can install four simple-swap SATA hard disk drives in the simple-swap models.
- v Install the drives starting from the top bay to the bottom bay (bay 4, 5, 6, and then 7).
- v The four simple-swap SATA hard disk drive connects to the SATA 0 through SATA 3 connectors on the system board as follows:
 - The drive in bay 4 connects to the SATA 0 connector on the system board.
 - The drive in bay 5 connects to the SATA 1 connector on the system board.
 - The drive in bay 6 connects to the SATA 2 connector on the system board.
 - The drive in bay 7 connects to the SATA 3 connector on the system board.

Attention: Simple-swap hard disk drives are not hot-swappable. Disconnect all power from the server before you remove or install a simple-swap hard disk drive.

To install a simple-swap hard disk drive, complete the following steps:

1. Read the safety information that begins on page vii and “Installation guidelines” on page 29.
2. Turn off the server and peripheral devices and disconnect all external cables and power cords.
3. Unlock the side cover (the bezel will not disengage from the server if the cover is locked).
4. Remove the lower bezel (see “Removing the two-piece bezel” on page 32).
5. Touch the static-protective package that contains the drive to any unpainted metal surface on the server; then, remove the drive from the package and place it on a static-protective surface.
6. Align the drive assembly with the guide rails in the bay (the connector end of the drive goes in first).

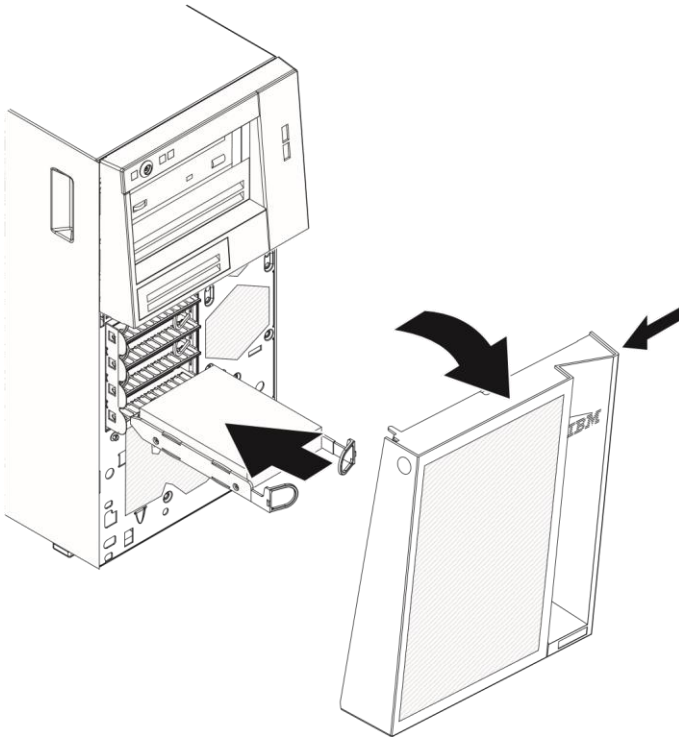

7. Pull the loops of the drive assembly toward each other; then, carefully slide the drive assembly into the drive bay until it stops, and release the loops.

Note: Do not release the loops on the drive assembly until it is completely seated.

If you have other devices to install or remove, do so now; otherwise, go to “Completing the installation” on page 62.

The simple-swap-drive backplate controls the IDs of the internal simple-swap drive bays. The following table lists the IDs of the hard disk drives and backplate in simple-swap models.

Table 13. IDs of simple-swap drives

Drive bay	ID
4	0

Table 13. IDs of simple-swap drives (continued)

Drive bay	ID
5	1
6	2
7	3

Power and signal cables for internal drives

The server uses cables to connect SATA attached, simple-swap SATA, hot-swap SATA and hot-swap SAS devices to the power supply and to the system board. (See “System-board internal connectors” on page 24 for the location of system-board connectors.)

Review the following information before connecting power and signal cables to internal drives:

- v The drives that are preinstalled in the server come with power and signal cables attached. If you replace any drives, remember which cable is attached to which drive.

- v When you install a drive, make sure that one of the signal cable drive connectors is connected to the drive and that the connector at the other end of the signal cable is connected to the system board or a compatible adapter or controller that you have installed.
- v When you route a cable, make sure that it does not block the airflow to the rear of the drives or over the microprocessor or DIMMs.

The following cables are provided:

- v **Power cables:** Four-wire power cables connect the drives to the power supply. At the ends of these cables are plastic connectors that can be attached to different drives; these connectors vary in size. Use either a four-wire power cable or SATA power cable with SATA drives, but do not use both at the same time (use one or the other).
- v **Signal cables:** Signal cables are typically flat cables, also called ribbon cables, that connect SATA attached, SATA and SAS to the system board. Two or three types of signal cables come with the server:
 - **SATA attached (for optical drives):** The flat SATA-attached signal cable has two connectors. One of these connectors is attached to the optical drive, and one is attached to one of the connectors on the system board.
 - **Simple-swap SATA:** Simple-swap SATA models come with four SATA cables that are already connected to the system board and the backplate at the rear of the simple-swap drive cage.
 - **Hot-swap SAS/SATA:** Hot-swap SAS/SATA models come with one or two (depending on the model) data cables that connect the SAS/SATA controller to the hot-swap backplane. The data cable provides inherent connectivity for the SAS or SATA drives that the server supports. Therefore, additional cabling is not required for these drives.

For more information about the requirements for SAS/SATA cables and connecting SAS/SATA devices, see the documentation that comes with these devices.

For a list of supported optional devices for the server, see <http://www.ibm.com/servers/eserver/serverproven/compat/us/>.

Installing an adapter

The following notes describe the types of adapters that the server supports and other information that you must consider when you install an adapter. Adapter that the server supports might vary, depending on your server model.

- v Locate the documentation that comes with the adapter and follow those instructions in addition to the instructions in this section. If you must change the switch setting or jumper settings on the adapter, follow the instructions that come with the adapter.
- v Read the documentation that comes with your operating system.
- v The server comes with the following adapter connectors or slots:
 - Slot 1, PCIe2 x8 (x8, x4, x1) 25W
 - Slot 2, PCIe2 x8 (x8, x4, x1) 25W
 - Slot 3, PCIe2 x1 10W
 - Slot 4, PCI 32bit, 33MHz
 - Slot 5, PCI 32bit, 33MHz

Note: If you are installing Intel Ethernet Quad Port Server Adapter I340-T4 (part number 49Y4240), you can only install the adaptor in slot 1 or slot 2.

-
- v Some server models come with a ServeRAID-BR10il v2 SAS/SATA RAID controller installed. The ServeRAID-BR10il v2 controller enables integrated RAID levels-0 and level-1.
 - v The optional ServeRAID-MR10i adapter can be purchased and supports RAID levels 0, 1, 5, 6, and 10. The optional ServeRAID-MR10is VAULT adapter with an encryption 1078 DE chip set can be purchased and supports RAID levels 0, 1, 5, 6, and 10. For configuration information, see the ServeRAID documentation at <http://www.ibm.com/systems/support/>.
 - v The optional ServeRAID-MR10i SAS/SATA controller and the optional ServeRAID-MR10is VAULT controller must be installed in slot 1 or slot 2 (PCI Express x8).
 - v You can install full-length adapters that are included in the ServerProven® list in slots 3 through 5 (depending on your model).
 - v The 32-bit slots 4 and 5 support 5.0 V keyed PCI adapters; they do not support 3.3 V keyed adapters. Universal adapters are supported in slots 4 and 5 if they are universally keyed.
 - v The server scans PCI Express Gen 2 x8 (x8) slot 1, PCI Express Gen 2 x8 (x8) slot 2, PCI Express Gen 2 x4 (x4) slot 3, and PCI slots 4 and 5 to assign system resources. Then, the server starts the PCI devices in the following order, if you have not changed the default startup sequence: PCI Express Gen 2 x8 (x8) slot 1, PCI Express Gen 2 x8 (x8) slot 2, PCI Express Gen 2 x4 (x4) slot 3, PCI slot 4, and PCI slot 5.
 - v For a list of supported options for the server, see <http://www.ibm.com/servers/eserver/serverproven/compat/us/>.

To install an adapter, complete the following steps.

Note: Static electricity that is released to internal server components when the server is powered-on might cause the server to stop, which might result in the loss of data. To avoid this potential problem, always use an electrostatic-discharge wrist strap or other grounding system when you work inside the server with the power on.

1. Read the safety information that begins on page vii and “Installation guidelines” on page 29.
2. Turn off the server and peripheral devices and disconnect all external cables and power cords; then, remove the side cover. See “Removing the side cover” on page 32.
3. Follow the cabling instructions, if any, that come with the adapter. Route the adapter cables before you install the adapter.
4. Follow the instructions that come with the adapter to set jumpers or switches, if any.
5. Rotate the rear adapter-retention bracket to the open position and remove it from the server.
6. Remove the screw that secures the expansion-slot cover to the chassis. Store the expansion-slot cover and screw in a safe place for future use.

Note: Expansion-slot covers must be installed on all vacant slots. This maintains the electronic emissions standards of the server and ensures proper ventilation of server components.

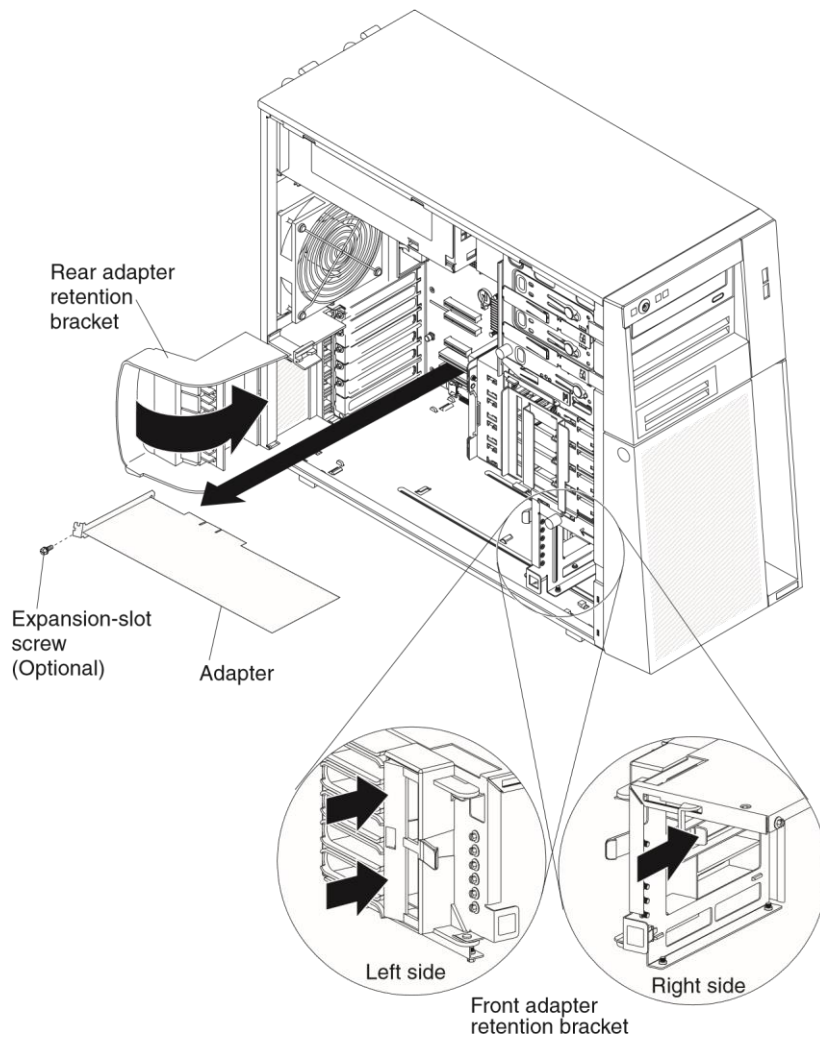

7. Touch the static-protective package that contains the adapter to any unpainted metal surface on the server. Then, remove the adapter from the static-protective package. Avoid touching the components and gold-edge connectors on the adapter.
8. If you are installing a full-length adapter, remove the blue adapter guide (if any) from the end of the adapter.

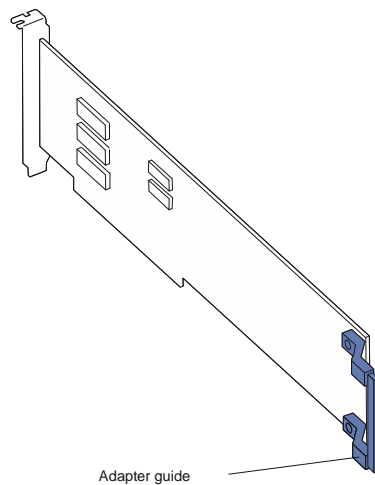

- Carefully grasp the adapter by the top edge or upper corners, and align it with the expansion slot guides; then, press the adapter *firmly* into the expansion slot. Move the adapter directly from the static-protective package to the expansion slot.

Attention: Make sure that the adapter is correctly seated in the expansion slot before you turn on the server. Incomplete installation of an adapter might damage the system board or the adapter.

- Install an expansion-slot screw at the rear of the adapter.
- If you are installing a full-length adapter, press on the release lever on the right side of the front adapter-retention bracket to release the retaining tab on the left side of the bracket.
- Connect required cables to the adapter. Route cables so that they do not block the flow of air from the fans.
- Reinstall the rear adapter-retention bracket; then, rotate the bracket to the closed position.

Note: If any adapters in the server are large or have heavy cables attached to them, you can remove the rear adapter-retention bracket and secure all of the adapters with expansion-slot screws.

If you have other devices to install or remove, do so now; otherwise, go to “Completing the installation” on page 62.

Installing the ServeRAID-BR10il v2 SAS/SATA controller

The IBM ServeRAID-BR10il v2 SAS/SATA controller must be installed in its dedicated connector, PCI slot 1, on the system board. The ServeRAID-BR10il v2 adapter is supported on hot-swap server models only. The IBM ServeRAID-BR10il v2 SAS/SATA adapter enables integrated RAID levels 0, 1, and 1E capability on hot-swap hard disk drives. For configuration information, see the ServeRAID documentation at <http://www.ibm.com/systems/support/>.

Attention: Some cluster solutions require specific code levels or coordinated code updates. If the device is part of a cluster solution, verify that the latest level of code is supported for the cluster solution before you update the code.

To install the ServeRAID-BR10il v2 adapter, complete the following steps:

- Read the safety information beginning on page vii, and “Installation guidelines” on page 29.
- Turn off the server and peripheral devices, and disconnect the power cords and all external cables. Remove the side cover (see “Removing the side cover” on page 32).

Attention: To avoid breaking the retaining clips or damaging the ServeRAID-BR10il v2 adapter connector, open and close the clips gently.

- Touch the static-protective package that contains the SAS/SATA controller to any unpainted surface on the outside of the server; then, remove the SAS/SATA controller from the package.
- Position the SAS/SATA controller over the connector and the plastic standoff; then, press the SAS/SATA controller firmly into the connector and onto the plastic standoff.

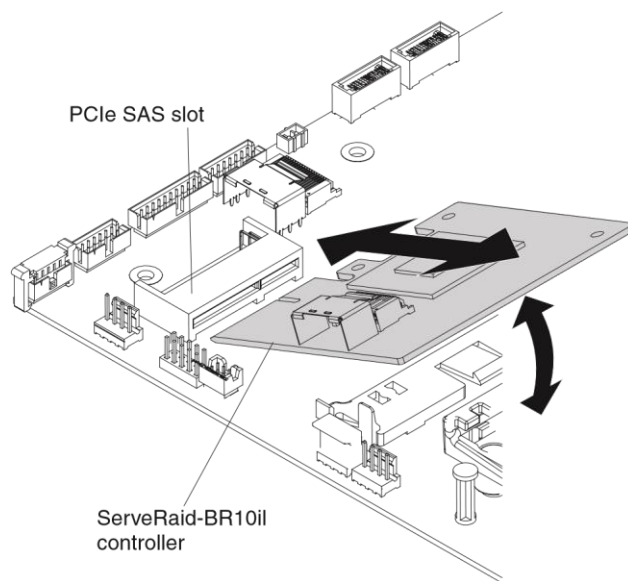

5. Connect the signal cable to the SAS/SATA controller.
6. Replace the side cover (see “Reinstalling the side cover” on page 64). Go to “Completing the installation” on page 62.
7. Lock the side cover.
8. Reconnect the external cables and power cords; then, turn on the attached devices and turn on the server.

If you have other devices to install or remove, do so now. Otherwise, go to “Completing the installation” on page 62.

Installing the IBM ServeRAID-MR10i SAS/SATA controller

The optional IBM ServeRAID-MR10i SAS/SATA controller can be installed in either PCI slot 1 or 2 on the system board. The ServeRAID-MR10i adapter is supported on hot-swap server models only. The IBM ServeRAID-MR10i SAS/SATA adapter enables integrated RAID levels 0, 1, 5, 6, and 10 support capability on hot-swap hard disk drives. For configuration information, see the documentation on the ServeRAID CD that comes with the adapter.

Important: To ensure that any of your ServeRAID-MR10i, ServeRAID-MR10is, or 10M adapters function properly on UEFI-based servers, make sure that the adapter firmware level is updated to at least 11.xx-XXX, and the supporting drivers.

Attention: Some cluster solutions require specific code levels or coordinated code updates. If the device is part of a cluster solution, verify that the latest level of code is supported for the cluster solution before you update the code.

To install the ServeRAID-MR10i adapter, complete the following steps:

1. Read the safety information that begins on page vii and “Installation guidelines” on page 29.
2. Turn off the server and peripheral devices, and disconnect the power cords and all external cables.

Attention: To avoid breaking the retaining clips or damaging the ServeRAID-MR10i adapter connector, open and close the clips gently.

3. Unlock and remove the side cover (see “Removing the side cover” on page 32).

4. Remove the hard disk drive fan assembly:
 - a. Rotate the hard disk drive fan assembly cable out of the system board.
 - b. Remove all hard disk drives.
 - c. Press and hold the drive cage release tab on the side of the drive cage; then, rotate the drive cage out of the chassis until the retaining tab on top of the cage locks into place.
 - d. Pull out on the hard disk drive fan assembly release tabs (at the blue dots); then, rotate the hard disk drive fan assembly away from the drive cage slightly.
5. Disconnect the signal and power cables and the existing SAS/SATA controller (if one is installed); then, remove the controller from the server.
6. Touch the static-protective package that contains the ServeRAID-MR10i SAS/SATA controller to any unpainted metal surface on the server. Then, remove the ServeRAID-MR10i SAS/SATA controller from the package.
7. Align the ServeRAID-MR10i SAS/SATA controller so that the keys align correctly with the connector on the system board.

Attention: Incomplete insertion might cause damage to the system board or the ServeRAID-MR10i controller.

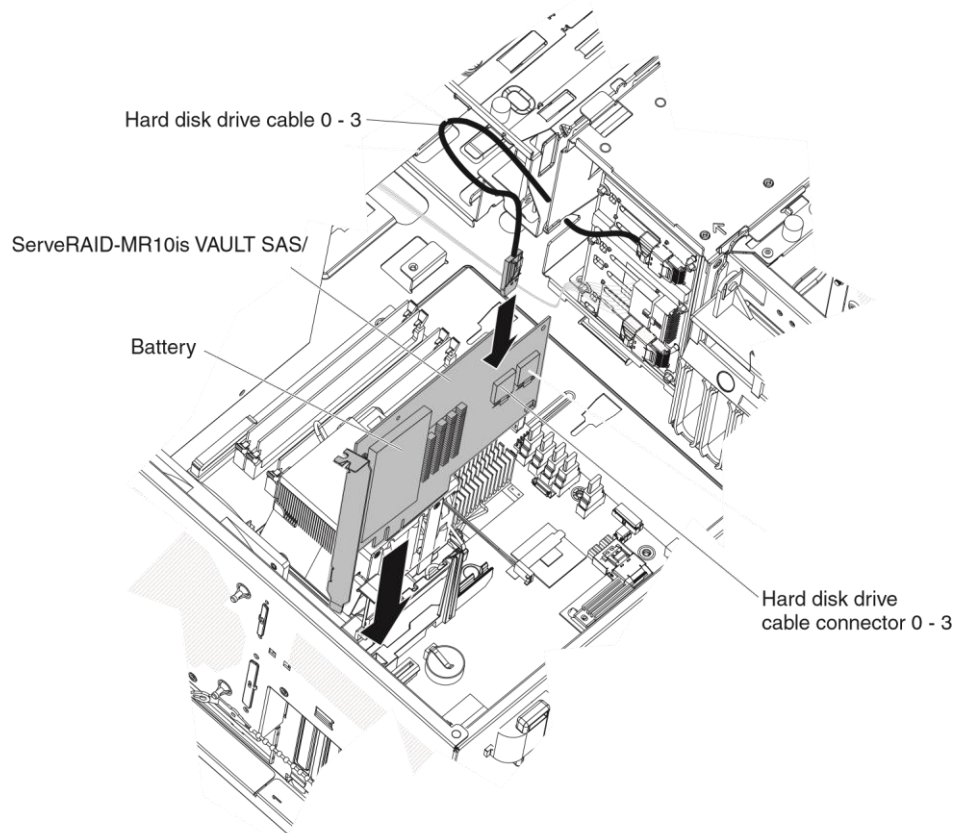

Note: The drive cage should be in the open position. This illustration shows it in the closed position.

8. Press the ServeRAID-MR10i SAS/SATA controller firmly into the connector on the system board.
9. Take the other end of the signal cable that is attached to the drive backplane section for drive bays 0 through 3 (as labeled on the front of the drive cage) and connect it to the connector that is closest to the battery on the ServeRAID-MR10i SAS/SATA controller.
10. Replace the hard disk drive fan assembly:

- a. Insert the hard disk drive fan assembly retaining tab over the right edge of the hard disk drive backplane; then, rotate the hard disk drive fan assembly toward the backplane. Do not fully close the hard disk drive fan assembly.
 - b. Route the signal cables and power cable through the slot on the edge of the hard disk drive fan assembly. Make sure that the cables will not be pinched between the hard disk drive fan assembly and the hard disk drive backplane when the assembly is installed.
 - c. Rotate the hard disk drive fan assembly toward the backplane until the release tabs are fully engaged and snap into place.
11. Reconnect the hard disk drive fan assembly cable to the system board.
 12. Rotate the drive cage back into the server until it stops; then, press and hold the retaining tab on top of the drive cage while you rotate the drive cage into the chassis until it is in the closed position.
 13. Reinstall the hard disk drives.

Note: Before you continue, check all internal power cables to make sure that they are connected to the system board and other optional devices.
 14. Replace the side cover (see “Reinstalling the side cover” on page 64). Go to “Completing the installation” on page 62.
 15. Lock the side cover.
 16. Reconnect the external cables and power cords; then, turn on the attached devices and turn on the server.

Installing the IBM ServeRaid-MR-10is VAULT SAS/SATA controller

The optional IBM ServeRAID-MR10is VAULT SAS/SATA controller can be installed in either PCI slot 1 or 2 on the system board. The ServeRAID-MR10is adapter is supported on hot-swap server models only. The IBM ServeRAID-MR10is VAULT SAS/SATA adapter enables integrated RAID levels 0, 1, 5, 6, and 10 support capability on hot-swap hard disk drives. For configuration information, see the documentation on the ServeRAID CD that comes with the adapter.

Important: To ensure that any of your ServeRAID-MR10i, ServeRAID-MR10is, or 10M adapters function properly on UEFI-based servers, make sure that the adapter firmware level is updated to at least 11.xx-XXX, and the supporting drivers.

Attention: Some cluster solutions require specific code levels or coordinated code updates. If the device is part of a cluster solution, verify that the latest level of code is supported for the cluster solution before you update the code.

To install the ServeRAID-MR10is adapter, complete the following steps:

1. Read the safety information that begins on page vii and “Installation guidelines” on page 29.
2. Turn off the server and peripheral devices, and disconnect the power cords and all external cables.

Attention: To avoid breaking the retaining clips or damaging the ServeRAID-MR10is adapter connector, open and close the clips gently.

3. Unlock and remove the side cover (see “Removing the side cover” on page 32).
4. Remove the hard disk drive fan assembly:
 - a. Rotate the hard disk drive fan assembly cable out of the system board.

- b. Remove all hard disk drives.
 - c. Press and hold the drive cage release tab on the side of the drive cage; then, rotate the drive cage out of the chassis until the retaining tab on top of the cage locks into place.
 - d. Pull out on the hard disk drive fan assembly release tabs (at the blue dots); then, rotate the hard disk drive fan assembly away from the drive cage slightly.
5. Disconnect the signal and power cables and the existing SAS/SATA controller (if one is installed); then, remove the controller from the server.
 6. Touch the static-protective package that contains the ServeRAID-MR10is SAS/SATA controller to any unpainted metal surface on the server. Then, remove the ServeRAID-MR10is SAS/SATA controller from the package.
 7. Align the ServeRAID-MR10is SAS/SATA controller so that the keys align correctly with the connector on the system board.

Attention: Incomplete insertion might cause damage to the system board or the ServeRAID-MR10is controller.

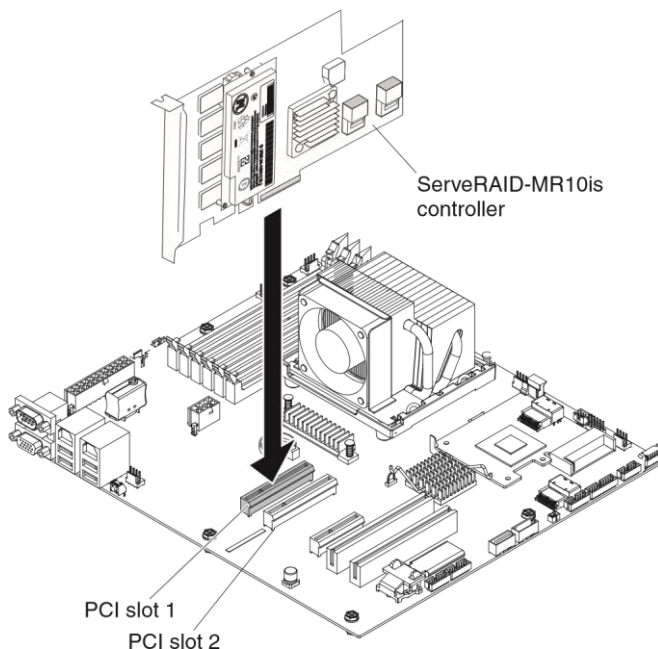

Note: The drive cage should be in the open position. This illustration shows it in the closed position.

8. Press the ServeRAID-MR10is SAS/SATA controller firmly into the connector on the system board.
9. Take the other end of the signal cable that is attached to the drive backplane section for drive bays 0 through 3 (as labeled on the front of the drive cage) and connect it to the connector that is closest to the battery on the ServeRAID-MR10is SAS/SATA controller.
10. Replace the hard disk drive fan assembly:
 - a. Insert the hard disk drive fan assembly retaining tab over the right edge of the hard disk drive backplane; then, rotate the hard disk drive fan assembly toward the backplane. Do not fully close the hard disk drive fan assembly.
 - b. Route the signal cables and power cable through the slot on the edge of the hard disk drive fan assembly. Make sure that the cables will not be pinched between the hard disk drive fan assembly and the hard disk drive backplane when the assembly is installed.

- c. Rotate the hard disk drive fan assembly toward the backplane until the release tabs are fully engaged and snap into place.
11. Reconnect the hard disk drive fan assembly cable to the system board.
12. Rotate the drive cage back into the server until it stops; then, press and hold the retaining tab on top of the drive cage while you rotate the drive cage into the chassis until it is in the closed position.
13. Reinstall the hard disk drives.

Note: Before you continue, check all internal power cables to make sure that they are connected to the system board and other optional devices.

14. Replace the side cover (see “Reinstalling the side cover” on page 64). Go to “Completing the installation” on page 62.
15. Lock the side cover.
16. Reconnect the external cables and power cords; then, turn on the attached devices and turn on the server.

Installing the virtual media key

To install the virtual media key, complete the following steps:

1. Read the safety information that begins on page vii and “Installation guidelines” on page 29.
2. Unlock and remove the side cover (see “Removing the side cover” on page 32).
3. Align the virtual media key with the mounting tab and slide it down the tab onto the connector on the system board. Press the virtual media key down into the connector until it is firmly seated on the system board.

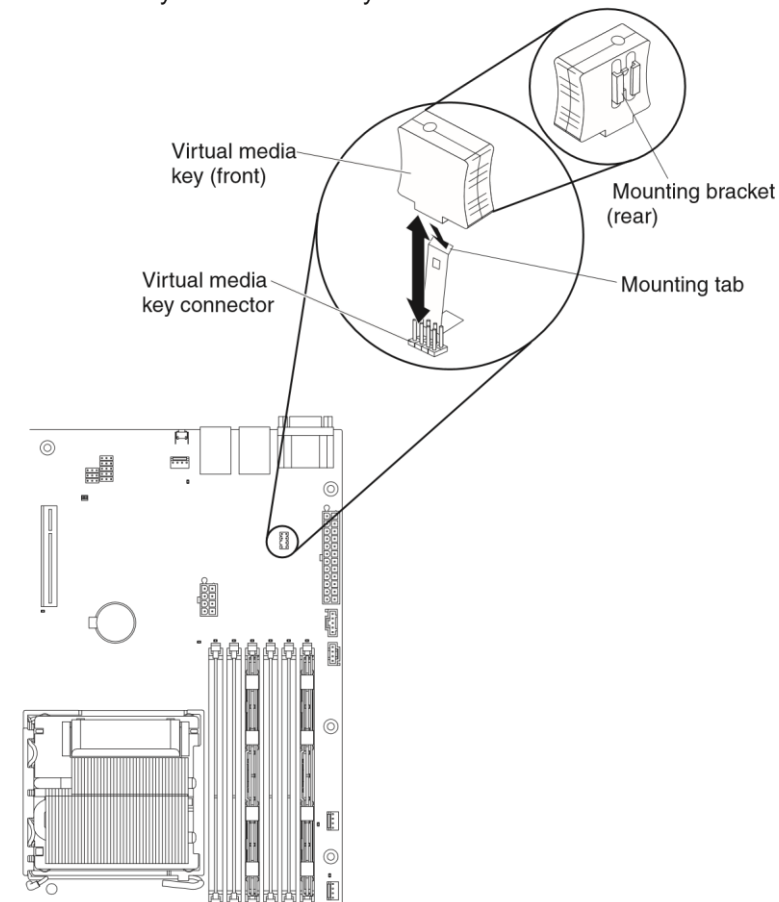

If you have other devices to install or remove, do so now. Otherwise, go to “Completing the installation” on page 62.

Installing a hot-swap power supply

The following notes describe the type of power supply that the server supports and other information that you must consider when you install a power supply:

- v The type and number of power supplies vary by server model. The server comes with at least one power supply.
- v Some servers come with a hot-swap power supply that supports redundant mode. The redundant mode requires two operational hot-swap power supplies in the server.

This procedure applies only to server models that have hot-swap power supplies. If the server contains a non-hot-swap power supply that requires replacement, the power supply must be replaced by a service technician.

When you remove or install a hot-swap power supply, observe the following precautions.

Statement 8:



CAUTION:

Never remove the cover on a power supply or any part that has the following label attached.



Hazardous voltage, current, and energy levels are present inside any component that has this label attached. There are no serviceable parts inside these components. If you suspect a problem with one of these parts, contact a service technician.

To replace a hot-swap power supply, complete the following steps:

1. Review the safety information that begins on page vii and “Installation guidelines” on page 29.
2. Disconnect the power cord from the power supply that is to be removed.
3. Press down on the orange release lever and pull the power supply out of the bay, using the handle.

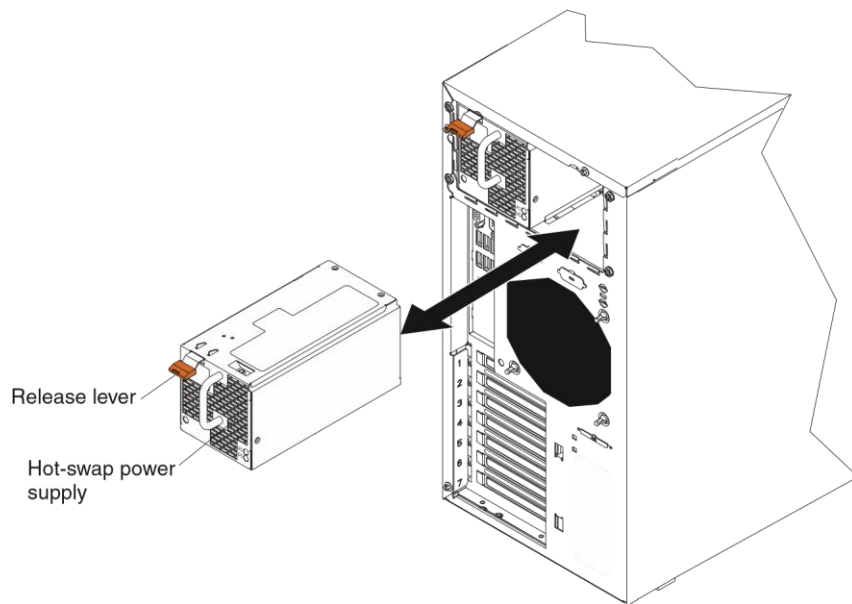

4. If you are instructed to return the hot-swap power supply, follow all packaging instructions, and use any packaging materials for shipping that are supplied to you.
5. Touch the static-protective package that contains the hot-swap power supply to any unpainted metal surface on the server; then, remove the power supply from the package and place it on a static-protective surface.
6. Place the power supply into the bay guides.
7. Press down on the orange release lever and push the power supply toward the front of the chassis until it locks into place.
8. Connect one end of the power cord into the connector on the back of the power supply and connect the other end of the power cord into a properly grounded electrical outlet.
9. Make sure that both the ac and dc power LEDs on the rear of the power supply are lit, indicating that the power supply is operating correctly.

Go to “Completing the installation” on page 62 for information about completing the installation.

Installing a security rope clip

To help prevent hardware theft, you can add a security rope clip and cable to the server. After you add the security cable, make sure that it does not interfere with other cables that are connected to the server.

Before you begin, obtain the following items:

- ✓ A flat-blade screwdriver
- ✓ An adjustable wrench
- ✓ A 19 mm (0.75 in.) rope clip or wire rope (similar to National Manufacturing number 3230, stock number 176-735)
- ✓ Threaded nuts that fit the rope clip
- ✓ A security cable
- ✓ A lock, such as a combination lock or padlock

To install a rope clip, complete the following steps:

1. Turn off the server and all attached devices. Disconnect all external cables and power cords.
2. Use a screwdriver to remove the two metal knockouts.
3. Insert the rope clip through the rear panel; then, attach and tighten the nuts.

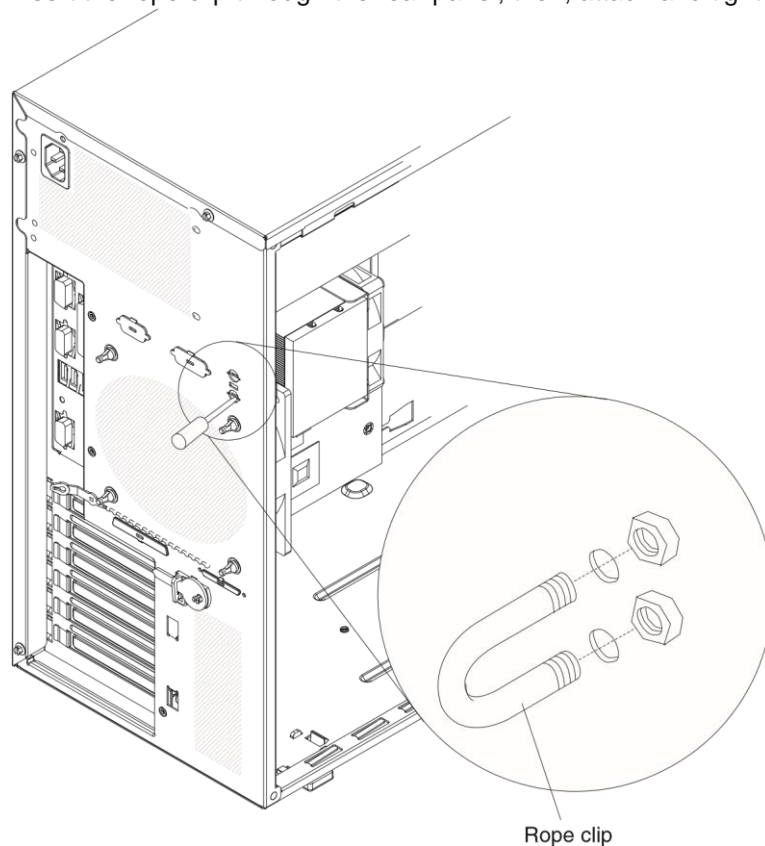

4. Thread the cable through the rope clip and around an object that is not part of or permanently secured to the building structure or foundation, and from which the cable cannot be removed. Fasten the cable ends together with a lock. After you add the security cable, make sure that it does not interfere with other cables that are connected to the server.

If you have other devices to install or remove, do so now; otherwise, go to “Completing the installation.”

Completing the installation

To complete the installation, you must reinstall the two-piece bezel, reinstall the side cover, connect all the cables and, for some devices, run the Setup utility. Follow the instructions in this section.

Reinstalling the two-piece bezel

To reinstall the two-piece bezel, complete the following steps:

1. Install the upper bezel on the front of the server chassis:
 - a. Insert the two right-side tabs on the upper bezel into the matching holes on the right side of the chassis.
 - b. Rotate the upper bezel to the left side of the chassis and press the bezel clips into the matching indentations on the left side of the chassis until the bezel clips snap into place.

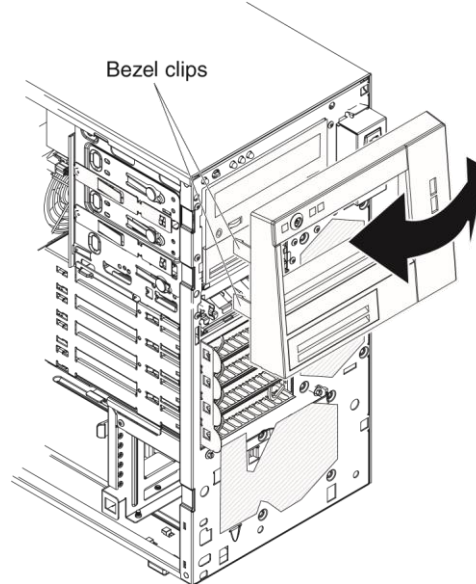

2. Install the lower bezel:
 - a. Insert the two bottom tabs on the lower bezel into the matching holes in the front of the chassis.

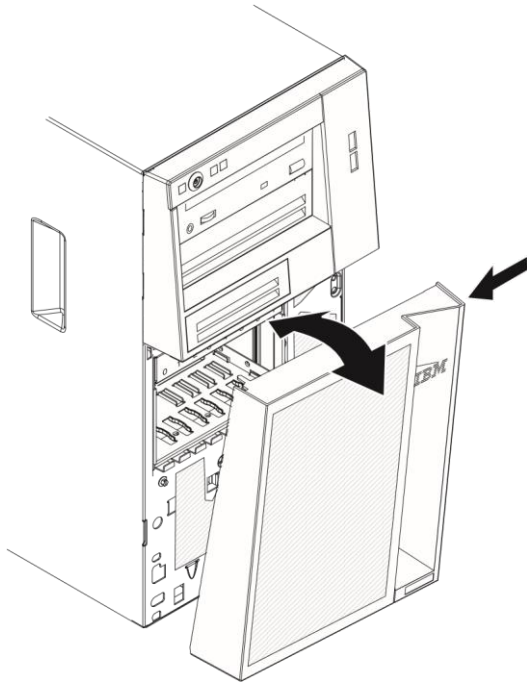

- b. Rotate the top of the lower bezel up to the chassis; then, press the blue release tab on the right side of the lower bezel and completely close the lower bezel until it locks securely into place.

Reinstalling the side cover

If you removed the side cover, reinstall it.

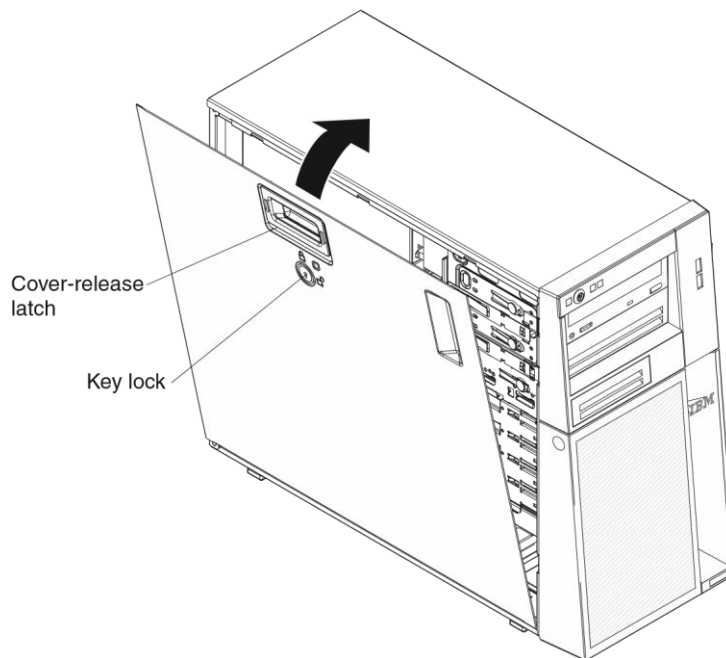

Note: The rear adapter-retention bracket rests against the server side cover. You might find it easier to lay the server on its side to replace the side cover.

To reinstall the side cover, complete the following steps:

1. Make sure that all cables, adapters, and other components are installed and seated correctly and that you have not left loose tools or parts inside the server. Also, make sure that all internal cables are correctly routed.

Note: The cover-release latch must be in the unlocked (opened) position before you install the side cover.

2. Position the lip on the bottom edge of the side cover on the ledge on the bottom of the chassis; then, rotate the cover up to the chassis, and then press down on the cover release latch and push the cover completely closed until it latches securely into place.
3. Press down on the cover-release latch and close the cover to secure it in place.
4. Lock the side cover.

Note: When you lock the server side cover, it locks both the cover and the bezel.

Connecting the cables

Attention: To prevent damage to equipment, connect the power cords last.

If the server cables and connector panel have color-coded connections, match the color of the cable end with the color of the connector. For example, match a blue cable end with a blue panel connector, a red cable end with a red connector, and so on.

The following illustration shows the input/output (I/O) connectors on the rear of the server.

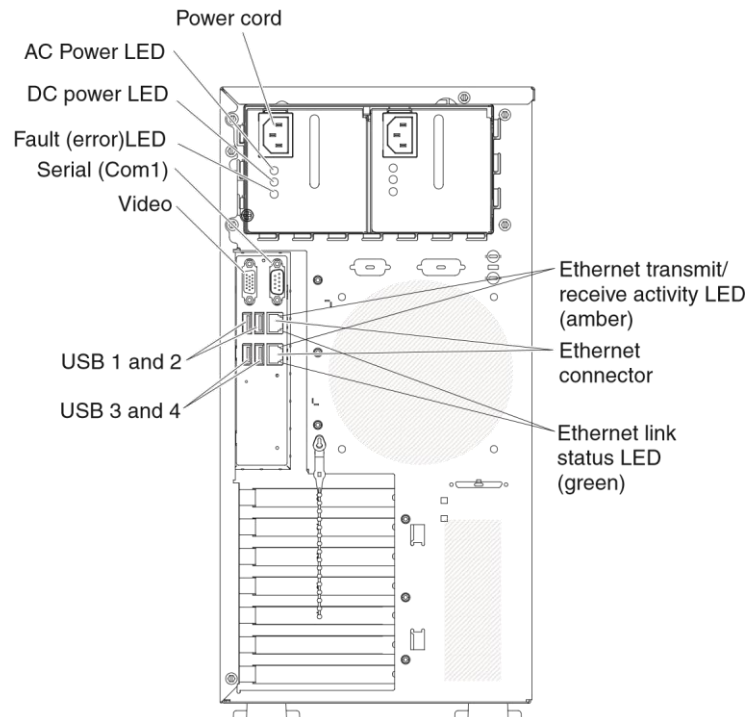

Updating the server configuration

When you start the server for the first time after you add or remove an internal option or an external device, you might receive a message that the configuration has changed. The Setup utility starts automatically so that you can save the new configuration settings. For additional information, see “Using the Setup utility” on page 68.

Some options have device drivers that you must install. For information about installing device drivers, see the documentation that comes with each option.

If the server has a ServeRAID adapter and you have installed or removed a hard disk drive, see the ServeRAID documentation for information about reconfiguring the disk arrays.

Connecting external devices

If you install a supported optional adapter, you can attach external devices to the server.

To attach an external device, complete the following steps:

1. Read the safety information that begins on page vii, “Installation guidelines” on page 29, and the documentation that comes with the device.
2. Turn off the server and all attached devices.
3. Follow the instructions that come with the device to prepare it for installation and to connect it to the server.

Note: If you are attaching an external device, see the documentation that comes with the device for information about cabling.

Installing the server in a rack

To convert the server from a tower model to a rack model, you must use a Tower-to-Rack Kit. You can then install the server in a rack cabinet. To order a Tower-to-Rack Kit for the server, contact your IBM marketing representative or authorized reseller.

Note: The Tower-to-Rack Kit does not support the server models that have eight 2.5-inch SAS hot-swap drive bays. You cannot install these models in a rack cabinet.

Chapter 3. Configuring the server

The following configuration programs and utilities come with the server: v

Setup utility

The UEFI (formerly BIOS) Setup Utility program is part of the basic input/output system firmware. Use it to change interrupt request (IRQ) settings, change the startup-device sequence, set the date and time, and set passwords. For information about using this program, see “Using the Setup utility” on page 68. v

Boot Manager program

The Boot Manager program is part of the server firmware. Use it to override the startup sequence that is set in the Setup utility and temporarily assign a device to be first in the startup sequence. For more information about using this program, see “Using the Boot Manager program” on page 73.

v **IBM ServerGuide Setup and Installation CD**

The ServerGuide program provides software-setup tools and installation tools that are designed for the server. Use this CD during the installation of the server to configure basic hardware features, such as an integrated SAS/SATA controller with RAID capabilities, and to simplify the installation of your operating system. For information about using this CD, see “Using the ServerGuide Setup and Installation CD” on page 74.

v **Integrated management module**

Use the integrated management module (IMM) for configuration, to update the firmware and sensor data record/field replaceable unit (SDR/FRU) data, and to remotely manage a network. For information about using the IMM, see “Using the integrated management module” on page 76.

v **VMware ESXi embedded hypervisor**

The VMware ESXi embedded hypervisor is available on the server models that come with an installed the USB embedded hypervisor flash device. The USB flash device is installed in the USB connector on the system board. Hypervisor is virtualization software that enables multiple operating systems to run on a host system at the same time. For more information about using the embedded hypervisor, see “Using the embedded hypervisor” on page 77.

v **Remote presence capability and blue-screen capture**

The remote presence and blue-screen capture feature are integrated into the integrated management module (IMM). The virtual media key is required to enable the remote presence functions. When the optional virtual media key is installed in the server, it activates the remote presence functions. Without the virtual media key, you will not be able to access the network remotely to mount or unmount drives or images on the client system. However, you will still be able to access the Web interface without the virtual media key. You can order the optional IBM Virtual Media Key, if one did not come with your server. For more information about how to enable the remote presence function, see “Enabling the remote presence feature” on page 79. v

Ethernet controller configuration

For information about configuring the Ethernet controller, see “Configuring the Gigabit Ethernet controller” on page 80. v

LSI Configuration Utility program

Use the LSI Configuration Utility program to configure the integrated SAS/SATA controller with RAID capabilities and the devices that are attached to it. For

information about using this program, see “Using LSI Configuration Utility program” on page 81

© Copyright IBM Corp. 2010

The following table lists the different server configurations and the applications that are available for configuring and managing RAID arrays.

Table 14. Server configuration and applications for configuring and managing RAID arrays

Server configuration	RAID array configuration (before operating system is installed)	RAID array management (after operating system is installed)
ServeRAID-BR10i v2 adapter installed	LSI Utility (Setup utility, press Ctrl+C), ServerGuide	MegaRAID Storage Manager (for monitoring storage only)
ServeRAID-MR10i adapter installed	MegaRAID Storage Manager (MSM), MegaRAID BIOS Configuration Utility (press C to start), ServerGuide	MegaRAID Storage Manager (MSM)
ServeRAID-MR10is VAULT adapter installed	MegaRAID Storage Manager (MSM), MegaRAID BIOS Configuration Utility (press C to start), ServerGuide	MegaRAID Storage Manager (MSM)

▼ **IBM Advanced Settings Utility (ASU) program**

Use this program as an alternative to the Setup utility for modifying UEFI settings and IMM settings. Use the ASU program online or out of band to modify UEFI settings from the command line without the need to restart the server to access the Setup utility. For more information about using this program, see “IBM Advanced Settings Utility program” on page 83.

Using the Setup utility

Use the setup utility program to perform the following tasks: ▼ View configuration information ▼ View and change assignments for devices and I/O ports ▼ Set the date and time ▼ Set the startup characteristics of the server and the order of startup devices ▼ Set and change settings for advanced hardware features ▼ View, set, and change settings for power-management features ▼ View and clear error logs ▼ Resolve configuration conflicts

Starting the Setup utility

To start the Setup utility, complete the following steps:

1. Turn on the server.

Note: Approximately 1 to 3 minutes after the server is connected to ac power, the power-control button becomes active.

2. When the prompt <F1>Setup is displayed, press F1. If you have set an administrator password, you must type the administrator password to access the full Setup utility menu. If you do not type the administrator password, a limited Setup utility menu is available.
3. Select settings to view or change.

Setup utility menu choices

The following choices are on the Setup utility main menu. Depending on the version of the firmware, some menu choices might differ slightly from these descriptions.

v System Information

Select this choice to view information about the server. When you make changes through other choices in the Setup utility, some of those changes are reflected in the system information; you cannot change settings directly in the system information. This choice is on the full Setup utility menu only.

– System Summary

Select this choice to view configuration information, including the ID, speed, and cache size of the microprocessor, machine type and model of the server, the serial number, the system UUID, and the amount of installed memory. When you make configuration changes through other options in the Setup utility, the changes are reflected in the system summary; you cannot change settings directly in the system summary.

– Product Data

Select this choice to view the system-board identifier, the revision level or issue date of the firmware, the integrated management module and diagnostics code, and the version and date.

This choice is on the full Setup utility menu only.

v System Settings

Select this choice to view or change the server component settings.

– Processors

Select this choice to view or change the processor settings.

– Memory

Select this choice to view or change the memory settings.

– Devices and I/O Ports

Select this choice to view or change assignments for devices and input/output (I/O) ports. You can configure the serial ports; configure remote console redirection; enable or disable integrated Ethernet controllers. If you disable a device, it cannot be configured, and the operating system will not be able to detect it (this is equivalent to disconnecting the device).

– Power

Select this choice to view or change power capping to control consumption, processors, and performance states.

– Legacy Support

Select this choice to view or set legacy support.

- Force Legacy Video on Boot

Select this choice to force INT video support, if the operating system does not support UEFI video output standards.

- Rehook INT 19h

Select this choice to enable or disable devices from taking control of the boot process. The default is **Disable**.

- Legacy Thunk Support

Select this choice to enable or disable UEFI to interact with PCI mass storage devices that are non-UEFI compliant.

– Integrated Management Module

Select this choice to view or change the settings for the integrated management module.

- POST Watchdog Timer

Select this choice to view or enable the POST watchdog timer.

- **POST Watchdog Timer Value**

Select this choice to view or set the POST loader watchdog timer value.

- **Reboot System on NMI**

Enable or disable restarting the system whenever a nonmaskable interrupt (NMI) occurs. **Enable** is the default.

- **Commands on USB Interface Preference**

Select this choice to enable or disable the Ethernet over USB interface on IMM.

- **Network Configuration**

Select this choice to view the system management network interface port, the IMM MAC address, the current IMM IP address, and the host name; define the static IMM IP address, subnet mask, and gateway address; specify whether to use the static IP address or have DHCP assign the IMM IP address; save the network changes; and reset the IMM.

- **Reset IMM to Defaults**

Select this choice to view or reset IMM to the default settings.

- **Reset IMM**

Select this choice to reset IMM.

- **System Security**

Select this choice to view or configure Trusted Platform Module (TPM) support.

- **Adapters and UEFI Drivers**

Select this choice to view information about the UEFI 1.10 and UEFI 2.0 compliant adapters and drivers installed in the server.

- **Network**

Select this choice to view or configure the network device options, such as iSCSI, PXE, and network devices.

- v **Date and Time**

Select this choice to set the date and time in the server, in 24-hour format (*hour:minute:second*).

This choice is on the full Setup utility menu only.

- v **Start Options**

Select this choice to view or boot to devices, including the startup sequence. The server starts from the first boot record that it finds.

The startup sequence specifies the order in which the server checks devices to find a boot record. The server starts from the first boot record that it finds. This choice is on the full Setup utility menu only. v **Boot Manager**

Select this choice to view, add, delete, or change the device boot priority, boot from a file, select a one-time boot, or reset the boot order to the default setting.

If the server has Wake on LAN hardware and software and the operating system supports Wake on LAN functions, you can specify a startup sequence for the Wake on LAN functions. For example, you can define a startup sequence that checks for a disc in the CD-RW/DVD drive, then checks the hard disk drive, and then checks a network adapter.

- v **System Event Logs**

Select this choice to enter the System Event Manager, where you can view the POST event log and system-event log.

The POST event log contains the three most recent error codes and messages that were generated during POST.

The system-event log contains POST and system management interrupt (SMI) events and all events that are generated by the baseboard management controller that is embedded in the integrated management module.

Important: If the system-error LED on the front of the server is lit but there are no other error indications, clear the system-event log. Also, after you complete a repair or correct an error, clear the system-event log to turn off the system-error LED on the front of the server.

– **POST Event Viewer**

Select this choice to enter the POST event viewer to view the POST event log.

– **System Event Log**

Select this choice to view the system event-log.

– **Clear System Event Log**

Select this choice to clear the system event-log.

v **User Security**

Select this choice to set or clear passwords. See “Passwords” on page 72 for more information.

This choice is on the full and limited Setup utility menu.

– **Power-on Password**

Select this choice to set a power-on password. See “Power-on password” on page 72 for more information.

– **Administrator Password**

Select this choice to set an administrator password. An administrator password is intended to be used by a system administrator; it limits access to the full Setup utility menu. If an administrator password is set, the full Setup utility menu is available only if you type the administrator password at the password prompt. For more information, see “Administrator password” on page 72.

v **Save Settings**

Select this choice to save the changes that you have made in the settings. v **Restore Settings**

Select this choice to cancel the changes that you have made in the settings and restore the previous settings. v **Load Default Settings**

Select this choice to cancel the changes that you have made in the settings and restore the factory settings.

v **Exit Setup**

Select this choice to exit from the Setup utility. If you have not saved the changes that you have made in the settings, you are asked whether you want to save the changes or exit without saving them.

Passwords

From the **User Security** menu choice, you can set, change, and delete a power-on password and an administrator password. The **User Security** choice is on the full Setup utility menu only.

If you set only a power-on password, you must type the power-on password to complete the system startup and to have access to the full Setup utility menu.

An administrator password is intended to be used by a system administrator; it limits access to the full Setup utility menu. If you set only an administrator password, you do not have to type a password to complete the system startup, but you must type the administrator password to access the Setup utility menu.

If you set a power-on password for a user and an administrator password for a system administrator, you must type the power-on password to complete the system startup. A system administrator who types the administrator password has access to the full Setup utility menu; the system administrator can give the user authority to set, change, and delete the power-on password. A user who types the power-on password has access to only the limited Setup utility menu; the user can set, change, and delete the power-on password, if the system administrator has given the user that authority.

Power-on password

If a power-on password is set, when you turn on the server, the system startup will not be completed until you type the power-on password. You can use any combination of between six and 20 printable ASCII characters for the password.

When a power-on password is set, you can enable the Unattended Start mode, in which the keyboard and mouse remain locked but the operating system can start. You can unlock the keyboard and mouse by typing the power-on password.

If you forget the power-on password, you can regain access to the server in any of the following ways:

- v If an administrator password is set, type the administrator password at the password prompt. Start the Setup utility and reset the power-on password.
- v Remove the battery from the server and then reinstall it. See the *Problem Determination and Service Guide* on the IBM System x Documentation CD for instructions for removing the battery.
- v Change the position of the clear CMOS jumper on the system board to bypass the power-on password check. See “Administrator password” for additional information.

Attention: Before you change any switch settings or move any jumpers, turn off the server; then, disconnect all power cords and external cables. See the safety information that begins on page vii. Do not change settings or move jumpers on any system-board switch or jumper blocks that are not shown in this document.

The power-on password override jumper does not affect the administrator password.

Administrator password

If an administrator password is set, you must type the administrator password for access to the full Setup utility menu. You can use any combination of between six and 20 printable ASCII characters for the password.

Attention: If you set an administrator password and then forget it, there is no way to change, override, or remove it. You must replace the system board.

Resetting passwords

If you forget the power-on password or administrator password, you can move the clear-CMOS jumper block on the system board to pins 2 and 3, to clear CMOS memory and bypass the power-on or administrator password check. The jumper location is shown in the following illustration.

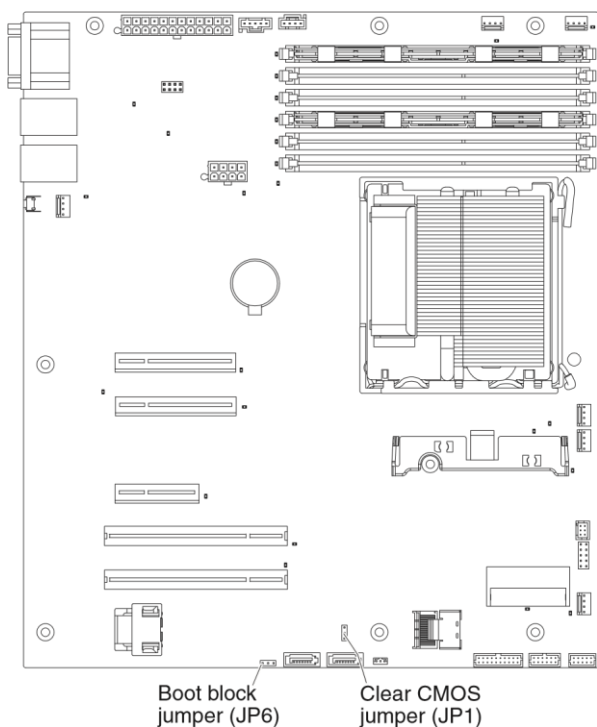

Using the Boot Manager program

The Boot Manager program is a built-in, menu-driven configuration utility program that you can use to temporarily redefine the first startup device without changing settings in the Setup utility.

To use the Boot Manager program, complete the following steps:

1. Turn off the server.
2. Restart the server.
3. When the prompt `<F12> Select Boot Device` is displayed, press F12. If a bootable USB mass storage device is installed, a submenu item (**USB Key/Disk**) is displayed.
4. Use the Up Arrow and Down Arrow keys to select an item from the **Boot Selection Menu** and press **Enter**.

The next time the server starts, it returns to the startup sequence that is set in the Setup utility.

Starting the backup server firmware

The system board contains a backup copy area for the server firmware. This is a secondary copy of the server firmware that you update only during the process of updating the server firmware. If the primary copy of the server firmware becomes damaged, use this backup copy.

To force the server to start from the backup copy, turn off the server; then, place the JP6 jumper in the backup position (pins 2 and 3).

Use the backup copy of the server firmware until the primary copy is restored. After the primary copy is restored, turn off the server; then, move the JP6 jumper back to the primary position (pins 1 and 2).

Using the ServerGuide Setup and Installation CD

The *ServerGuide Setup and Installation* CD provides software setup tools and installation tools that are designed for your server. The ServerGuide program detects the server model and hardware options that are installed and uses that information during setup to configure the hardware. Use this CD during the initial installation of the server to simplify the operating-system installations by providing updated device drivers and, in some cases, installing them automatically. To download the CD, go to <http://www.ibm.com/systems/management/serverguide/sub.html> and click **IBM Service and Support Site**.

Note: Changes are made periodically to the IBM Web site. The actual procedure might vary slightly from what is described in this document.

To start the *ServerGuide Setup and Installation* CD, complete the following steps:

1. Insert the CD, and restart the server. If the CD does not start, see “ServerGuide Problems” in the *Problem Determination and Service Guide* on the *System x Documentation* CD.
2. Follow the instructions on the screen to:
 - a. Select your language.
 - b. Select your keyboard layout and country.
 - c. View the overview to learn about ServerGuide features.
 - d. View the readme file to review installation tips for your operating system and adapter.
 - e. Start the operating-system installation. You will need your operating-system CD.

The ServerGuide program has the following features: v An easy-to-use interface v Diskette-free setup, and configuration programs that are based on detected hardware

v ServeRAID Manager program, which configures your ServeRAID adapter v Device drivers that are provided for your server model and detected hardware v Operating-system partition size and file-system type that are selectable during setup

ServerGuide features

Features and functions can vary slightly with different versions of the ServerGuide program. To learn more about the version that you have, start the *ServerGuide Setup and Installation* CD and view the online overview. Not all features are supported on all server models.

The ServerGuide program requires a supported IBM server with an enabled startable (bootable) CD drive. In addition to the *ServerGuide Setup and Installation* CD, you must have your operating-system CD to install the operating system.

The ServerGuide program performs the following tasks:

- v Sets system date and time
- v Detects the RAID adapter or controller and runs the SAS/SATA RAID configuration program

- v Checks the microcode (firmware) levels of a ServeRAID adapter and determines whether a later level is available from the CD
- v Detects installed hardware options and provides updated device drivers for most adapters and devices
- v Provides diskette-free installation for supported Windows operating systems
- v Includes an online readme file with links to tips for your hardware and operating-system installation

Important: Before you install a legacy operating system (such as VMware) on a server with an LSI SAS controller, you must first complete the following steps:

1. Update the device driver for the LSI SAS controller to the latest level.
2. In the Setup utility, set **Legacy Only** as the first option in the boot sequence in the **Boot Manager** menu.
3. Using the LSI Configuration Utility program, select a boot drive.

For detailed information and instructions, go to <https://www-947.ibm.com/systems/support/supportsite.wss/docdisplay?Indocid=MIGR-5083225>.

Setup and configuration overview

When you use the *ServerGuide Setup and Installation* CD, you do not need setup diskettes. You can use the CD to configure any supported IBM server model. The setup program provides a list of tasks that are required to set up your server model. On a server with a ServeRAID adapter or SAS/SATA controller with RAID capabilities, you can run the SAS/SATA RAID configuration program to create logical drives.

Note: Features and functions can vary slightly with different versions of the ServerGuide program.

Typical operating-system installation

The ServerGuide program can reduce the time it takes to install an operating system. It provides the device drivers that are required for your hardware and for the operating system that you are installing. This section describes a typical ServerGuide operating-system installation.

Note: Features and functions can vary slightly with different versions of the ServerGuide program.

1. After you have completed the setup process, the operating-system installation program starts. (You will need your operating-system CD to complete the installation.)
2. The ServerGuide program stores information about the server model, service processor, hard disk drive controllers, and network adapters. Then, the program checks the CD for newer device drivers. This information is stored and then passed to the operating-system installation program.
3. The ServerGuide program presents operating-system partition options that are based on your operating-system selection and the installed hard disk drives.
4. The ServerGuide program prompts you to insert your operating-system CD and restart the server. At this point, the installation program for the operating system takes control to complete the installation.

Installing your operating system without using ServerGuide

If you have already configured the server hardware and you are not using the ServerGuide program to install your operating system, complete the following steps to download the latest operating-system installation instructions from the IBM Web site.

Note: Changes are made periodically to the IBM Web site. The actual procedure might vary slightly from what is described in this document.

1. Go to <http://www.ibm.com/systems/support/>.
2. Under **Product support**, click **System x**.
3. From the menu on the left side of the page, click **System x support search**.
4. From the **Task** menu, select **Install**.
5. From the **Product family** menu, select **System x3200 M3**.
6. From the **Operating system** menu, select your operating system, and then click **Search** to display the available installation documents.

Using the integrated management module

The integrated management module (IMM) is a second generation of the functions that were formerly provided by the baseboard management controller hardware. It combines service processor functions, video controller, and (when an optional virtual media key is installed) remote presence function in a single chip.

For more information about IMM, see the *Integrated Management Module User's Guide* at <http://www.ibm.com/systems/support/supportsite.wss/docdisplay?Indocid=MIGR-5079770&brandind=5000008>

The IMM supports the following basic systems-management features:

- √ Environmental monitor with fan speed control for temperature, voltages, fan failure, and power supply failure.
- √ DIMM error assistance. The Unified Extensible Firmware Interface (UEFI) disables a failing DIMM that is detected during POST, and the IMM lights the associated system error LED and the failing DIMM error LED. √ System event-log (SEL).
- √ ROM-based IMM firmware flash updates. √ Auto Boot Failure Recovery (ABR).
- √ A virtual media key, which enables remote presence support (remote video, remote keyboard/mouse, and remote storage).
- √ Nonmaskable interrupt (NMI) detection and reporting.
- √ Automatic Server Restart (ASR) when POST is not complete or the operating system hangs and the operating system watchdog timer times-out. The IMM might be configured to watch for the operating system watchdog timer and reboot the system after a timeout, if the ASR feature is enabled. Otherwise, the IMM allows the administrator to generate a nonmaskable interrupt (NMI) by pressing an NMI button on the system board for an operating-system memory dump. ASR is supported by IPMI.
- √ Intelligent Platform Management Interface (IPMI) Specification V2.0 and Intelligent Platform Management Bus (IPMB) support. √ Invalid system configuration (CNFG) LED support. √ Serial port redirection over Telnet or

- SSH.
- v Serial over LAN (SOL).
- v Active Energy Manager.
- v Query power-supply input power.
- v PECI 2 support.
- v Power/reset control (power-on, hard and soft shutdown, hard and soft reset, schedule power control).
- v Alerts (in-band and out-of-band alerting, PET traps - IPMI style, SNMP, e-mail).
- v Operating-system failure blue screen capture.
- v Command-line interface.
- v Configuration save and restore.
- v PCI configuration data.
- v Boot sequence manipulation.

The IMM also provides the following remote server management capabilities through the OSA SMBridge management utility program:

v **Command-line interface (IPMI Shell)**

The command-line interface provides direct access to server management functions through the IPMI 2.0 protocol. Use the command-line interface to issue commands to control the server power, view system information, and identify the server. You can also save one or more commands as a text file and run the file as a script.

v **Serial over LAN**

Establish a Serial over LAN (SOL) connection to manage servers from a remote location. You can remotely view and change the UEFI settings, restart the server, identify the server, and perform other management functions. Any standard Telnet client application can access the SOL connection.

Using the embedded hypervisor

The VMware ESXi embedded hypervisor is available on server models that come with an installed USB embedded hypervisor flash device. The USB flash device installs in the USB connector on the system board (see the following illustration). Hypervisor is virtualization software that enables multiple operating systems to run on a host system at the same time. The USB flash device is required to activate the hypervisor functions.

To start using the embedded hypervisor functions, you must add the USB flash device to the boot order in the Setup utility.

To add the USB flash device to the boot order, complete the following steps:

1. Turn on the server.
 - Note:** Approximately 1 to 3 minutes after the server is connected to ac power, the power-control button becomes active.
2. When the prompt <F1> Setup is displayed, press F1.
3. From the Setup utility main menu, select **Boot Manager**.
4. Select **Add Boot Option**; then, select **Embedded Hypervisor**. Press Enter, and then select Esc.
5. Select **Change Boot Order** and then select **Commit Changes**; then, press Enter.
6. Select **Save Settings** and then select **Exit Setup**.

If the embedded hypervisor flash device image becomes corrupt, you can use the *VMware Recovery* CD that comes with the system to recover the flash device image. To recover the flash device image, complete the following steps:

1. Turn on the server.

Note: Approximately 1 to 3 minutes after the server is connected to ac power, the power-control button becomes active.

2. Insert the VMware Recovery CD into the CD or DVD drive.
3. Follow the instructions on the screen.

For additional information and instructions, see the *VMware ESXi Server 31 Embedded Setup Guide* at http://www.vmware.com/pdf/vi3_35/esx_3i_e/r35/vi3_35_25_3i_setup.pdf

Using the remote presence capability and blue-screen capture

The remote presence and blue-screen capture features are integrated functions of the integrated management module (IMM). When the optional IBM Virtual Media Key is installed in the server, it activates the remote presence functions. The virtual media key is required to enable the integrated remote presence and blue-screen capture features. Without the virtual media key, you will not be able to access the network remotely to mount or unmount drives or images on the client system. However, you can still access the Web interface without the key.

After the virtual media key is installed in the server, it is authenticated to determine whether it is valid. If the key is not valid, you receive a message from the Web interface (when you attempt to start the remote presence feature) indicating that the hardware key is required to use the remote presence feature.

The virtual media key has an LED. When this LED is lit and green, it indicates that the key is installed and functioning correctly. When the LED is not lit, it indicates that the key might not be installed correctly.

The remote presence feature provides the following functions:

- v Remotely viewing video with graphics resolutions up to 1280 x 1024 at 75 Hz, regardless of the system state
- v Remotely accessing the server, using the keyboard and mouse from a remote client
- v Mapping the CD or DVD drive, diskette drive, and USB flash drive on a remote client, and mapping ISO and diskette image files as virtual drives that are available for use by the server
- v Uploading a diskette image to the IMM memory and mapping it to the server as a virtual drive

The blue-screen capture feature captures the video display contents before the IMM restarts the server when the IMM detects an operating-system hang condition. A system administrator can use the blue-screen capture to assist in determining the cause of the hang condition.

Enabling the remote presence feature

To enable the remote presence feature, complete the following steps:

1. Install the virtual media key into the dedicated slot on the system board (see “System-board optional-device connectors” on page 25).
2. Turn on the server.

Note: Approximately 1 to 3 minutes after the server is connected to ac power, the power-control button becomes active.

Obtaining the IP address for the IMM

To access the Web interface, you need the IP address for the IMM. You can obtain the IMM IP address through the Setup utility. The server comes with a default IP address for the IMM of 192.168.70.125. To locate the IP address, complete the following steps:

1. Turn on the server.

Note: Approximately 1 to 3 minutes after the server is connected to ac power, the power-control button becomes active.

2. When the prompt <F1>Setup is displayed, press F1. (This prompt is displayed on the screen for only a few seconds. You must press F1 quickly.) If you have set both a power-on password and an administrator password, you must type the administrator password to access the full Setup utility menu.
3. From the Setup utility main menu, select **System Settings**.
4. On the next screen, select **Integrated Management Module**.
5. On the next screen, select **Network Configuration**.
6. Find the IP address and write it down.
7. Exit from the Setup utility.

Logging on to the Web interface

To log on to the Web interface to use the remote presence functions, complete the following steps:

1. Open a Web browser on a computer that connects to the server and in the **address** or **URL** field, type the IP address or host name of the IMM to which you want to connect.

Note: The IMM defaults to DHCP. If a DHCP host is not available, the IMM assigns a static IP address of 192.168.70.125.

2. On the Login page, type the user name and password. If you are using the IMM for the first time, you can obtain the user name and password from your system administrator. All login attempts are documented in the event log.

Note: The IMM is set initially with a user name of USERID and password of PASSWORD (passwd0rd with a zero, not a the letter O). You have read/write access. You must change the default password the first time you log on.

3. On the Welcome page, type a timeout value (in minutes) in the field that is provided. The IMM will log you off of the Web interface if your browser is inactive for the number of minutes that you entered for the timeout value.
4. Click **Continue** to start the session. The System Health page provides a quick view of the system status.

Enabling the Intel Gigabit Ethernet Utility program

The Intel Gigabit Ethernet Utility program is part of the server firmware. You can use it to configure the network as a startable device, and you can customize where the network startup option appears in the startup sequence. Enable and disable the Intel Gigabit Ethernet Utility program from the Setup utility.

Configuring the Gigabit Ethernet controller

The Ethernet controllers are integrated on the system board. They provides an interface for connecting to a 10 Mbps, 100 Mbps, or 1 Gbps network and provides full-duplex (FDX) capability, which enables simultaneous transmission and reception of data on the network. If the Ethernet ports in the server supports auto-negotiation, the controllers detect the data-transfer rate (10BASE-T, 100BASE-TX, or 1000BASE-T) and duplex mode (full-duplex or half-duplex) of the network and automatically operates at that rate and mode.

You do not have to set any jumpers or configure the controller. However, you must install a device driver to enable the operating system to address the controller. To find updated information about configuring the controllers, complete the following steps.

Note: Changes are made periodically to the IBM Web site. The actual procedure might vary slightly from what is described in this document.

1. Go to <http://www.ibm.com/systems/support/>.
2. Under **Product support**, click **System x**.
3. Under **Popular links**, click **Software and device drivers**.
4. From the **Product family** menu, select **System x3200 M3** and click **Go**.

Enabling and configuring Serial over LAN (SOL)

Establish a Serial over LAN (SOL) connection to manage servers from a remote location. You can remotely view and change the BIOS settings, restart the server, identify the server, and perform other management functions. Any standard Telnet client application can access the SOL connection.

To enable and configure the server for SOL, you must update and configure the UEFI code; update and configure the integrated management module (IMM) firmware; update and configure the Ethernet controller firmware; and enable the operating system for an SOL connection.

UEFI update and configuration

To update and configure the UEFI code to enable SOL, complete the following steps:

1. Update the UEFI code:
 - a. Download the latest version of the UEFI code from <http://www.ibm.com/systems/support/>.
 - b. Update the UEFI code, following the instructions that come with the update file that you downloaded.
2. Update the IMM firmware:
 - a. Download the latest version of the IMM firmware from <http://www.ibm.com/systems/support/>.
 - b. Update the IMM firmware, following the instructions that come with the update file that you downloaded.
3. Configure the UEFI settings:
 - a. When you are prompted to start the Configuration/Setup Utility program, restart the server and press F1.

- b. Select **System Settings** → **Devices and I/O Ports**.
- c. Select **Console Redirection Settings**; then, make sure that the values are set as follows:
 - √ **COM Port 1**: Enable √ **Remote Console**: Enable √ **Serial Port Sharing**: Enable √ **Serial Port Access Mode**: Dedicated COM1 Settings √ **Baud Rate**: 115200 √ **Data Bits**: 8 √ **Parity**: None Stop √ **Bits**: 1 √ **Thermal Emulation**: ANSI √ **Active After Boot**: Enable √ **Flow Control**: Hardware
- d. Press Esc twice to exit the **Devices and I/O Ports** section of the Configuration/Setup Utility program.
- e. Select **Save Settings**; then, press Enter.
- f. Press Enter to confirm.
- g. Select **Exit Setup**; then, press Enter.
- h. Make sure that Yes, exit the Setup Utility is selected; then, press Enter.

Using LSI Configuration Utility program

Use the LSI Configuration Utility program to configure and manage redundant array of independent disks (RAID) arrays. Be sure to use this program as described in this document.

- √ Use the LSI Configuration Utility program to perform the following tasks:
 - Perform a low-level format on a hard disk drive
 - Create an array of hard disk drives with or without a hot-spare drive
 - Set protocol parameters on hard disk drives

The integrated SAS/SATA controller with RAID capabilities supports RAID arrays. You can use the LSI Configuration Utility program to configure RAID 1 (IM), RAID 1E (IME), and RAID 0 (IS) for a single pair of attached devices. If you install the optional ServeRAID-MR10i SAS/SATA controller, it provides RAID levels 0, 1, 5, 6, and 10 support. If you install a different type of RAID adapter, follow the instructions in the documentation that comes with the adapter to view or change settings for attached devices.

In addition, you can download an LSI command-line configuration program from <http://www.ibm.com/systems/support/>.

When you are using the LSI Configuration Utility program to configure and manage arrays, consider the following information:

- √ The integrated SAS/SATA controller with RAID capabilities supports the following features:
 - Integrated Mirroring (IM) with hot-spare support (also known as RAID 1)
 - Use this option to create an integrated array of two disks plus up to two optional hot spares. All data on the primary disk can be migrated.
 - Integrated Mirroring Enhanced (IME) with hot-spare support (also known as RAID 1E)
 - Use this option to create an integrated mirror enhanced array of three to eight disks, including up to two optional hot spares. All data on the array disks will be deleted.

- Integrated Striping (IS) (also known as RAID 0)
Use this option to create an integrated striping array of two to eight disks. All data on the array disks will be deleted.
- v Hard disk drive capacities affect how you create arrays. The drives in an array can have different capacities, but the RAID controller treats them as if they all have the capacity of the smallest hard disk drive.
- v If you use an integrated SAS/SATA controller with RAID capabilities to configure a RAID 1 (mirrored) array after you have installed the operating system, you will lose access to any data or applications that were previously stored on the secondary drive of the mirrored pair.
- v If you install a different type of RAID controller, see the documentation that comes with the controller for information about viewing and changing settings for attached devices.

Starting the LSI Configuration Utility program

To start the LSI Configuration Utility program, complete the following steps:

1. Turn on the server.

Note: Approximately 1 to 3 minutes after the server is connected to ac power, the power-control button becomes active.

2. When the prompt <F1Setup> is displayed, press F1. If you have set an administrator password, you are prompted to type the password.
3. Select **System Settings** → **Adapters and UEFI drivers**.
4. Select **Please refresh this page on the first visit** and press Enter.
5. Select **LSI controller_driver_name Driver** and press Enter, where *controller_driver_name* is the name of the SAS/SATA controller driver. For the SAS/SATA controller driver name, see the documentation that comes with your controller.
6. To perform storage-management tasks, follow the procedures in the documentation that comes with the SAS/SATA controller.

When you have finished changing settings, press Esc to exit from the program; select **Save** to save the settings that you have changed.

Formatting a hard disk drive

Low-level formatting removes all data from the hard disk. If there is data on the disk that you want to save, back up the hard disk before you perform this procedure.

Note: Before you format a hard disk, make sure that the disk is not part of a mirrored pair.

To format a drive, complete the following steps:

1. From the list of adapters, select the controller (channel) for the drive that you want to format and press Enter.
2. Select **SAS Topology** and press Enter.
3. Select **Direct Attach Devices** and press Enter.
4. To highlight the drive that you want to format, use the Up Arrow and Down Arrow keys. To scroll left and right, use the Left Arrow and Right Arrow keys or the End key. Press Alt+D.

5. To start the low-level formatting operation, select **Format** and press Enter.

Creating a RAID array of hard disk drives

To create a RAID array of hard disk drives, complete the following steps:

1. From the list of adapters, select the controller (channel) for the drives that you want to mirror.
2. Select **RAID Properties**.
3. Select the type of array that you want to create.
4. Use the arrow keys to highlight the first drive in the pair; then, press the Minus (-) or Plus (+) key to change the mirror value to **Primary**.
5. Continue to select the next drive using the Minus (-) or Plus (+) key until you have selected all the drives for your array.
6. Press C to create the disk array.
7. Select **Apply changes and exit menu** to create the array.

IBM Advanced Settings Utility program

The IBM Advanced Settings Utility (ASU) program is an alternative to the Setup utility for modifying UEFI settings. Use the ASU program online or out of band to modify UEFI settings from the command line without the need to restart the system to access the Setup utility.

You can also use the ASU program to configure the optional remote presence features or other IMM settings. The remote presence features provide enhanced systems-management capabilities.

In addition, the ASU program provides limited settings for configuring the IPMI function in the IMM through the command-line interface.

Use the command-line interface to issue setup commands. You can save any of the settings as a file and run the file as a script. The ASU program supports scripting environments through a batch-processing mode.

For more information and to download the ASU program, go to <http://www.ibm.com/systems/support/>.

Updating IBM Systems Director

If you plan to use IBM Systems Director to manage the server, you must check for the latest applicable IBM Systems Director updates and interim fixes.

Note: Changes are made periodically to the IBM Web site. The actual procedure might vary slightly from what is described in this document.

To locate and install a newer version of IBM Systems Director, complete the following steps:

1. Check for the latest version of IBM Systems Director:
 - a. Go to <http://www.ibm.com/systems/management/director/downloads.html>.
 - b. If a newer version of IBM Systems Director than what comes with the server is shown in the drop-down list, follow the instructions on the Web page to download the latest version.

-
2. Install the IBM Systems Director program.

If your management server is connected to the Internet, to locate and install updates and interim fixes, complete the following steps:

1. Make sure that you have run the Discovery and Inventory collection tasks.
2. On the Welcome page of the IBM Systems Director Web interface, click **View updates**.
3. Click **Check for updates**. The available updates are displayed in a table.
4. Select the updates that you want to install, and click **Install** to start the installation wizard.

If your management server is not connected to the Internet, to locate and install updates and interim fixes, complete the following steps:

1. Make sure that you have run the Discovery and Inventory collection tasks.
2. On a system that is connected to the Internet, go to <http://www.ibm.com/eserver/support/fixes/fixcentral/>.
3. From the **Product family** list, select **IBM Systems Director**.
4. From the **Product** list, select **IBM Systems Director**.
5. From the **Installed version** list, select the latest version, and click **Continue**.
6. Download the available updates.
7. Copy the downloaded files to the management server.
8. On the management server, on the Welcome page of the IBM Systems Director Web interface, click the **Manage** tab, and click **Update Manager**.
9. Click **Import updates** and specify the location of the downloaded files that you copied to the management server.
10. Return to the Welcome page of the Web interface, and click **View updates**.
11. Select the updates that you want to install, and click **Install** to start the installation wizard.

Appendix A. Getting help and technical assistance

If you need help, service, or technical assistance or just want more information about IBM products, you will find a wide variety of sources available from IBM to assist you. This section contains information about where to go for additional information about IBM and IBM products, what to do if you experience a problem with your system, and whom to call for service, if it is necessary.

Before you call

Before you call, make sure that you have taken these steps to try to solve the problem yourself:

- ✓ Check all cables to make sure that they are connected.

- ✓ Check the power switches to make sure that the system and any optional devices are turned on.

- ✓ Use the troubleshooting information in your system documentation, and use the diagnostic tools that come with your system. Information about diagnostic tools is in the *Problem Determination and Service Guide* on the IBM Documentation CD that comes with your system.

- ✓ Go to the IBM support Web site at <http://www.ibm.com/systems/support/> to check for technical information, hints, tips, and new device drivers or to submit a request for information.

You can solve many problems without outside assistance by following the troubleshooting procedures that IBM provides in the online help or in the documentation that is provided with your IBM product. The documentation that comes with IBM systems also describes the diagnostic tests that you can perform. Most systems, operating systems, and programs come with documentation that contains troubleshooting procedures and explanations of error messages and error codes. If you suspect a software problem, see the documentation for the operating system or program.

Using the documentation

Information about your IBM system and preinstalled software, if any, or optional device is available in the documentation that comes with the product. That documentation can include printed documents, online documents, readme files, and help files. See the troubleshooting information in your system documentation for instructions for using the diagnostic programs. The troubleshooting information or the diagnostic programs might tell you that you need additional or updated device drivers or other software. IBM maintains pages on the World Wide Web where you can get the latest technical information and download device drivers and updates. To access these pages, go to <http://www.ibm.com/systems/support/> and follow the instructions. Also, some documents are available through the IBM Publications Center at <http://www.ibm.com/shop/publications/order/>.

Getting help and information from the World Wide Web

On the World Wide Web, the IBM Web site has up-to-date information about IBM systems, optional devices, services, and support. The address for IBM System x® and xSeries® information is <http://www.ibm.com/systems/x/>. The address for IBM

BladeCenter® information is <http://www.ibm.com/systems/bladecenter/>. The address for IBM IntelliStation® information is <http://www.ibm.com/intellistation/>.

© Copyright IBM Corp. 2010

You can find service information for IBM systems and optional devices at <http://www.ibm.com/systems/support/>.

Software service and support

Through IBM Support Line, you can get telephone assistance, for a fee, with usage, configuration, and software problems with System x and xSeries servers, BladeCenter products, IntelliStation workstations, and appliances. For information about which products are supported by Support Line in your country or region, see <http://www.ibm.com/services/sl/products/>.

For more information about Support Line and other IBM services, see <http://www.ibm.com/services/>, or see <http://www.ibm.com/planetwide/> for support telephone numbers. In the U.S. and Canada, call 1-800-IBM-SERV (1-800-426-7378).

Hardware service and support

You can receive hardware service through your IBM reseller or IBM Services. To locate a reseller authorized by IBM to provide warranty service, go to <http://www.ibm.com/partnerworld/> and click **Find a Business Partner** on the right side of the page. For IBM support telephone numbers, see <http://www.ibm.com/planetwide/>. In the U.S. and Canada, call 1-800-IBM-SERV (1-800-426-7378).

In the U.S. and Canada, hardware service and support is available 24 hours a day, 7 days a week. In the U.K., these services are available Monday through Friday, from 9 a.m. to 6 p.m.

IBM Taiwan product service

台灣 IBM 產品服務聯絡方式：
台灣國際商業機器股份有限公司
台北市松仁路 7 號 3 樓
電話：0800-016-888

IBM Taiwan product service contact information:

IBM Taiwan Corporation
3F, No 7, Song Ren Rd.
Taipei, Taiwan
Telephone: 0800-016-888

Appendix B. Notices

This information was developed for products and services offered in the U.S.A.

IBM may not offer the products, services, or features discussed in this document in other countries. Consult your local IBM representative for information on the products and services currently available in your area. Any reference to an IBM product, program, or service is not intended to state or imply that only that IBM product, program, or service may be used. Any functionally equivalent product, program, or service that does not infringe any IBM intellectual property right may be used instead. However, it is the user's responsibility to evaluate and verify the operation of any non-IBM product, program, or service.

IBM may have patents or pending patent applications covering subject matter described in this document. The furnishing of this document does not give you any license to these patents. You can send license inquiries, in writing, to:

*IBM Director of Licensing
IBM Corporation
North Castle Drive
Armonk, NY 10504-1785
U.S.A.*

INTERNATIONAL BUSINESS MACHINES CORPORATION PROVIDES THIS PUBLICATION "AS IS" WITHOUT WARRANTY OF ANY KIND, EITHER EXPRESS OR IMPLIED, INCLUDING, BUT NOT LIMITED TO, THE IMPLIED WARRANTIES OF NON-INFRINGEMENT, MERCHANTABILITY OR FITNESS FOR A PARTICULAR PURPOSE. Some states do not allow disclaimer of express or implied warranties in certain transactions, therefore, this statement may not apply to you.

This information could include technical inaccuracies or typographical errors. Changes are periodically made to the information herein; these changes will be incorporated in new editions of the publication. IBM may make improvements and/or changes in the product(s) and/or the program(s) described in this publication at any time without notice.

Any references in this information to non-IBM Web sites are provided for convenience only and do not in any manner serve as an endorsement of those Web sites. The materials at those Web sites are not part of the materials for this IBM product, and use of those Web sites is at your own risk.

IBM may use or distribute any of the information you supply in any way it believes appropriate without incurring any obligation to you.

Trademarks

IBM, the IBM logo, and [ibm.com](http://www.ibm.com) are trademarks or registered trademarks of International Business Machines Corporation in the United States, other countries, or both. If these and other IBM trademarked terms are marked on their first occurrence in this information with a trademark symbol (® or ™), these symbols indicate U.S. registered or common law trademarks owned by IBM at the time this information was published. Such trademarks may also be registered or common law trademarks in other countries. A current list of IBM trademarks is available on the Web at "Copyright and trademark information" at <http://www.ibm.com/legal/copytrade.shtml>.

© Copyright IBM Corp. 2010

Adobe and PostScript are either registered trademarks or trademarks of Adobe Systems Incorporated in the United States and/or other countries.

Cell Broadband Engine is a trademark of Sony Computer Entertainment, Inc., in the United States, other countries, or both and is used under license therefrom.

Intel, Intel Xeon, Itanium, and Pentium are trademarks or registered trademarks of Intel Corporation or its subsidiaries in the United States and other countries.

Java and all Java-based trademarks are trademarks of Sun Microsystems, Inc., in the United States, other countries, or both.

Linux is a registered trademark of Linus Torvalds in the United States, other countries, or both.

Microsoft, Windows, and Windows NT are trademarks of Microsoft Corporation in the United States, other countries, or both.

UNIX is a registered trademark of The Open Group in the United States and other countries.

Other company, product, or service names may be trademarks or service marks of others.

Important notes

Processor speed indicates the internal clock speed of the microprocessor; other factors also affect application performance.

CD or DVD drive speed is the variable read rate. Actual speeds vary and are often less than the possible maximum.

When referring to processor storage, real and virtual storage, or channel volume, KB stands for 1024 bytes, MB stands for 1 048 576 bytes, and GB stands for 1 073 741 824 bytes.

When referring to hard disk drive capacity or communications volume, MB stands for 1 000 000 bytes, and GB stands for 1 000 000 000 bytes. Total user-accessible capacity can vary depending on operating environments.

Maximum internal hard disk drive capacities assume the replacement of any standard hard disk drives and population of all hard disk drive bays with the largest currently supported drives that are available from IBM.

Maximum memory might require replacement of the standard memory with an optional memory module.

IBM makes no representation or warranties regarding non-IBM products and services that are ServerProven, including but not limited to the implied warranties of merchantability and fitness for a particular purpose. These products are offered and warranted solely by third parties.

IBM makes no representations or warranties with respect to non-IBM products. Support (if any) for the non-IBM products is provided by the third party, not IBM.

Some software might differ from its retail version (if available) and might not include user manuals or all program functionality.

Particulate contamination

Attention: Airborne particulates (including metal flakes or particles) and reactive gases acting alone or in combination with other environmental factors such as humidity or temperature might pose a risk to the server that is described in this document. Risks that are posed by the presence of excessive particulate levels or concentrations of harmful gases include damage that might cause the server to malfunction or cease functioning altogether. This specification sets forth limits for particulates and gases that are intended to avoid such damage. The limits must not be viewed or used as definitive limits, because numerous other factors, such as temperature or moisture content of the air, can influence the impact of particulates or environmental corrosives and gaseous contaminant transfer. In the absence of specific limits that are set forth in this document, you must implement practices that maintain particulate and gas levels that are consistent with the protection of human health and safety. If IBM determines that the levels of particulates or gases in your environment have caused damage to the server, IBM may condition provision of repair or replacement of servers or parts on implementation of appropriate remedial measures to mitigate such environmental contamination. Implementation of such remedial measures is a customer responsibility.

Table 15. Limits for particulates and gases

Contaminant	Limits
Particulate	<ul style="list-style-type: none"> ∨ The room air must be continuously filtered with 40% atmospheric dust spot efficiency (MERV 9) according to ASHRAE Standard 52.2¹. ∨ Air that enters a data center must be filtered to 99.97% efficiency or greater, using high-efficiency particulate air (HEPA) filters that meet MIL-STD-282. ∨ The deliquescent relative humidity of the particulate contamination must be more than 60%². ∨ The room must be free of conductive contamination such as zinc whiskers.
Gaseous	<ul style="list-style-type: none"> ∨ Copper: Class G1 as per ANSI/ISA 71.04-1985³ ∨ Silver: Corrosion rate of less than 300 Å in 30 days
<p>¹ ASHRAE 52.2-2008 - <i>Method of Testing General Ventilation Air-Cleaning Devices for Removal Efficiency by Particle Size</i>. Atlanta: American Society of Heating, Refrigerating and Air-Conditioning Engineers, Inc. ²</p> <p>The deliquescent relative humidity of particulate contamination is the relative humidity at which the dust absorbs enough water to become wet and promote ionic conduction. ³</p> <p>ANSI/ISA-71.04-1985. <i>Environmental conditions for process measurement and control systems: Airborne contaminants</i>. Instrument Society of America, Research Triangle Park, North Carolina, U.S.A.</p>	

Documentation format

The publications for this product are in Adobe Portable Document Format (PDF) and should be compliant with accessibility standards. If you experience difficulties when you use the PDF files and want to request a Web-based format or accessible PDF document for a publication, direct your mail to the following address:

Information Development
IBM Corporation
 205/A015

3039 E. Cornwallis Road
P.O. Box 12195
Research Triangle Park, North Carolina 27709-2195
U.S.A.

In the request, be sure to include the publication part number and title.

When you send information to IBM, you grant IBM a nonexclusive right to use or distribute the information in any way it believes appropriate without incurring any obligation to you.

Electronic emission notices

Federal Communications Commission (FCC) statement

Note: This equipment has been tested and found to comply with the limits for a Class A digital device, pursuant to Part 15 of the FCC Rules. These limits are designed to provide reasonable protection against harmful interference when the equipment is operated in a commercial environment. This equipment generates, uses, and can radiate radio frequency energy and, if not installed and used in accordance with the instruction manual, may cause harmful interference to radio communications. Operation of this equipment in a residential area is likely to cause harmful interference, in which case the user will be required to correct the interference at his own expense.

Properly shielded and grounded cables and connectors must be used in order to meet FCC emission limits. IBM is not responsible for any radio or television interference caused by using other than recommended cables and connectors or by unauthorized changes or modifications to this equipment. Unauthorized changes or modifications could void the user's authority to operate the equipment.

This device complies with Part 15 of the FCC Rules. Operation is subject to the following two conditions: (1) this device may not cause harmful interference, and (2) this device must accept any interference received, including interference that may cause undesired operation.

Industry Canada Class A emission compliance statement

This Class A digital apparatus complies with Canadian ICES-003.

Avis de conformité à la réglementation d'Industrie Canada

Cet appareil numérique de la classe A est conforme à la norme NMB-003 du Canada.

Australia and New Zealand Class A statement

Attention: This is a Class A product. In a domestic environment this product may cause radio interference in which case the user may be required to take adequate measures.

United Kingdom telecommunications safety requirement Notice to Customers

This apparatus is approved under approval number NS/G/1234/J/100003 for indirect connection to public telecommunication systems in the United Kingdom.

European Union EMC Directive conformance statement

This product is in conformity with the protection requirements of EU Council Directive 2004/108/EC on the approximation of the laws of the Member States relating to electromagnetic compatibility. IBM cannot accept responsibility for any failure to satisfy the protection requirements resulting from a nonrecommended modification of the product, including the fitting of non-IBM option cards.

This product has been tested and found to comply with the limits for Class A Information Technology Equipment according to CISPR 22/European Standard EN 55022. The limits for Class A equipment were derived for commercial and industrial environments to provide reasonable protection against interference with licensed communication equipment.

Attention: This is a Class A product. In a domestic environment this product may cause radio interference in which case the user may be required to take adequate measures.

European Community contact:
IBM Technical Regulations
Pascalstr. 100, Stuttgart, Germany 70569
Telephone: 0049 (0)711 785 1176
Fax: 0049 (0)711 785 1283
E-mail: tjahn@de.ibm.com

Taiwanese Class A warning statement

警告使用者：
這是甲類的資訊產品，在
居住的環境中使用時，可
能會造成射頻干擾，在這種
情況下，使用者會被要求
採取某些適當的對策。

Germany Electromagnetic Compatibility Directive

Deutschsprachiger EU Hinweis:

Hinweis für Geräte der Klasse A EU-Richtlinie zur Elektromagnetischen Verträglichkeit

Dieses Produkt entspricht den Schutzanforderungen der EU-Richtlinie 2004/108/EG zur Angleichung der Rechtsvorschriften über die elektromagnetische Verträglichkeit in den EU-Mitgliedsstaaten und hält die Grenzwerte der EN 55022 Klasse A ein.

Um dieses sicherzustellen, sind die Geräte wie in den Handbüchern beschrieben zu installieren und zu betreiben. Des Weiteren dürfen auch nur von der IBM empfohlene

Kabel angeschlossen werden. IBM übernimmt keine Verantwortung für die Einhaltung der Schutzanforderungen, wenn das Produkt ohne Zustimmung der

Appendix B. Notices

IBM verändert bzw. wenn Erweiterungskomponenten von Fremdherstellern ohne Empfehlung der IBM gesteckt/eingebaut werden.

EN 55022 Klasse A Geräte müssen mit folgendem Warnhinweis versehen werden: "Warnung: Dieses ist eine Einrichtung der Klasse A. Diese Einrichtung kann im Wohnbereich Funk-Störungen verursachen; in diesem Fall kann vom Betreiber verlangt werden, angemessene Maßnahmen zu ergreifen und dafür aufzukommen."

Deutschland: Einhaltung des Gesetzes über die elektromagnetische Verträglichkeit von Geräten

Dieses Produkt entspricht dem "Gesetz über die elektromagnetische Verträglichkeit von Geräten (EMVG)". Dies ist die Umsetzung der EU-Richtlinie 2004/108/EG in der Bundesrepublik Deutschland.

Zulassungsbescheinigung laut dem Deutschen Gesetz über die elektromagnetische Verträglichkeit von Geräten (EMVG) (bzw. der EMC EG Richtlinie 2004/108/EG) für Geräte der Klasse A

Dieses Gerät ist berechtigt, in Übereinstimmung mit dem Deutschen EMVG das EG-Konformitätszeichen - CE - zu führen. Verantwortlich für die Konformitätserklärung des EMVG ist die IBM Deutschland GmbH, 70548 Stuttgart.

Generelle Informationen:

Das Gerät erfüllt die Schutzanforderungen nach EN 55024 und EN 55022 Klasse A.

People's Republic of China Class A warning statement

声 明

此为 A 级产品。在生活环境中，该产品可能会造成无线电干扰。在这种情况下，可能需要用户对其干扰采取切实可行的措施。

Japanese Voluntary Control Council for Interference (VCCI) statement

この装置は、クラス A 情報技術装置です。この装置を家庭環境で使用する
と電波妨害を引き起こすことがあります。この場合には使用者が適切な対策
を講ずるよう要求されることがあります。

VCCI-A

Korean Class A warning statement

이 기기는 업무용으로 전자파 적합등록을 받은 기기 이오니, 판매자 또는 사용자는 이점을 주의하시기 바라며, 만약 잘못 구입하셨을 때에는 구입한 곳에서 비업무용으로 교환하시기 바랍니다.

Index

A

accessible documentation 89
acoustical noise emissions 7, 9
Active Energy Manager plug-in 11
adapter
 hot-plug devices
 installing 52
 hot-plug 50
 52
 requirements 50
 scanning order 50
 ServeRAID-BR10il v2 52
 ServeRAID-MR10i
 installing 53
 ServeRAID-MR10is
 installing 56
 specifications 7
administrator password 71
assistance, getting 85
attention notices 7
availability features 13
B
backplane 45, 47
backup firmware
 starting 74
battery
 connector 24
 safety x
bay identification 40
 bays
 hot-swap drives 44, 45
bays, filler panel 41, 43
before you install a legacy operating system 75
bezel
 installing 62
blue-screen capture feature
 overview 79
boot manager program
 using 73

C

cables
 internal drives 49
 power 49

 rear connectors 65
 signal 49
cabling
 hot-swap SAS drives 49
 hot-swap SATA drives 49
 Simple-swap SATA drives 49
 the ServeRAID-MR10i adapter 53
 the ServeRAID-MR10is adapter 56
caution statements 7
CD drive installing 40

© Copyright IBM Corp. 2010
Class A electronic emission notice 90
components installing in the server 23
 major 23
 system board 25
configuration
 Ethernet controller 80
 updating 65
configuration programs
 LSI Configuration Utility 67
configuring
 with ServerGuide 75
connector adapter 25
 battery 24
 cable 65
 Ethernet
 21 external
 19, 28 internal
 24 memory
 25
 microprocessor 25
 power cord 20
 serial 21
 system board 25
 Universal Serial Bus (USB) 19, 21
 video 21
connectors
 on the rear of the server 20
contamination, particulate and gaseous 8, 89
controller
 Ethernet, configuring 80
controls and indicators 15
cooling 8, 30
cover
 installing 64
 removing 32
creating
 RAID array 83

D

- danger statements 7
- data rate, Ethernet 80
- device drivers, updates 15
- diagnostics program
 - DSA Preboot 10
- DIMMs
 - installing 35
- DIMMs, registered 37
- DIMMs, unbuffered 36
- diskette drive installing
 - 40
- documentation
 - Documentation Browser 5
 - Documentation CD 5
 - documentation format 89
 - documentation, updated
 - finding 7
- drive
 - bay filler panel 41, 43
 - bay
 - identification 40
 - cables 49
 - hot-swap
 - installation 44
 - support 40
 - installing 40
 - removable-media 41
 - simple-swap 47
- drives
 - hot-swap SAS
 - cabling 49
 - hot-swap SATA
 - cabling 49
 - Simple-swap SATA
 - cabling 49
 - specifications 7
- DVD drive
 - activity LED 19
 - eject button 19
 - installing 41
- Dynamic System Analysis (DSA) Preboot
 - diagnostics program 10

E

- eject button
 - DVD 19
- electrical input 7, 8
- electromagnetic compatibility (EMC) shield 41, 42, 43
- electronic emission Class A notice 90
- embedded hypervisor
 - using 77
- environment 7, 8

- Ethernet
 - activity LED 21
 - connector 21
 - controller
 - configuring 80
 - high performance modes
 - 80 integrated on system board80
 - link status LED21
 - modes 80
- expansion card connectors 25
- expansion slots 9, 25, 51
- external connectors 28
- external connectors, rear of server 20

F

- FCC Class A notice 90
- features
 - reliability, availability, and serviceability 13
 - server 10
 - ServerGuide 75
- features and specifications 7
- features, server 7
- filler panel
 - removable-media drive bay
 - 42 removing 41, 43
- finding
 - updated documentation 7
- firmware updates 3
- formatting
 - hard disk drive 83
- front, controls and indicators 15

G

- gaseous contamination 8, 89
- getting help 85
- guidelines, system reliability 30

H

- handling static-sensitive devices 31
- hard disk drive
 - activity LED 18, 19
 - formatting 83
 - hot-swap 45
 - installing 40
 - order of installation 47
 - simple-swap 47
 - status LED 19
- hardware service and support 86
- heat output 7, 8
- help, getting 85
- hot-plug adapter.
 - See adapter hot-plug devices
- adapters 52
- hot-swap drive

- backplane activity LED 19
 - SAS IDs 47 status LED 19
- installation 44 specifications 7
- hot-swap power supply installing 60
 - removing 59 replacing 59 safety 59
- hot-swap SAS drives cabling 49
- hot-swap SATA drives cabling 49

I

- IBM Advanced Settings Utility program overview 83
- IBM Support Line 86
- IBM Systems Director 11 systems management tool 14 updating 84
- IDs for SAS hot-swap drives 47
- IMM IP address obtaining 79
- important notices 7 indicators 15 installation guidelines 29
- installation order
 - hard disk drives 47
- installing
 - adapters 50 an adapter 52 cover 64 DVD drive 41 hot-swap drives 44, 45 hot-swap power supply 59 internal drives 40 lower bezel 63 memory modules 35 options 29 power supply 60 removable-media drives 40 security rope clip 61 simple-swap drives 47 the ServeRAID-MR10i adapter 53 the ServeRAID-MR10is adapter 56 the virtual media key 58 upper bezel 62
- installing options in server 23
- installing the server
 - in a Tower-to-Rack Kit 66
- integrated baseboard management controller 22
- integrated functions 8 integrated management module overview 10
- integrated network support 11
- internal drives, installing 40
- IP address obtaining for the IMM 79

J

- jumpers

- on the system board 26
- jumpers on the system board 26

K

- key, virtual media installing 58

L

- LED
 - power-error (fault) 21
- LEDs
 - DVD drive activity 19
 - Ethernet link status 21 Ethernet transmit/receive activity 21 hard disk drive activity 18 hot-swap hard disk drive activity 19 hot-swap hard disk drive status 19 power-on 18 system board 29 system-error 18
- LEDs and controls on the front of the server 15 LEDs, on the rear of the server 20 legacy operating system requirement 75
- lower bezel installing 63 removing 33
- LSI Configuration program 81

M

- major components 23
- management, system 10
- memory
 - specifications 7
- memory module installing 35 specifications 8
- menu choices for the Setup utility 68
- microprocessor
 - specifications 7, 8
- modes, Ethernet 80

N

- NOS installation with ServerGuide 75 without ServerGuide 76
- notes 7
- notes, important 88 notices 87
 - electronic emission 90

FCC, Class A 90 notices
and statements 7

O

obtaining
the IP address for the IMM 79
online documentation 3
online publications 7 optional
device installation guidelines
29 static-sensitive 31
options
adapters 50
connectors 25
connectors, rear of server 20
drives40 installing
29
order of installation
hard disk drives 47
overview11, 12

P

particulate contamination 8, 89

password
administrator 72 forgotten
power-on 72 power-on
72
passwords 72
ports
Ethernet 21 serial 21 Universal Serial
Bus (USB) 19, 21 video 21
power control-button 18 power on and
working inside the server 31
power supply installing
59, 60 removing 59
replacing 59 safety 59
specifications 8
power switch 18 power-cord
connector 20
power-error (fault) LED 21
power-on LED 18, 21 power-on
password 71, 72

R

RAID adapter slot 50 RAID array creating 83
RAS features 13 RAS. *See also* features
reliability, availability, and serviceability 13
redundant array of independent disks (RAID)
adapter 46
support 12
redundant connection 12
related documentation 6

reliability features 13 reliability,
system 30
remote presence feature
using 78
removable-media drives, installing 40, 41
removing
cover 32
hot-swap power supply 59
lower bezel 33 upper bezel
34
replacing a hot-swap power supply 59
rope clip, installing for security
61

S

safety information
handling static-sensitive devices 31
introduction viii multilingual
pointer vii
Statement 1 ix
Statement 12 xiii
Statement 13 xiv
safety information (*continued*)
Statement 15 xiv
Statement 2 x
Statement 3 xi
Statement 4 xii
Statement 5 xii
Statement 8 xiii
system reliability considerations 30 when
the server is on 31
Safety Information 7
SATA hot-swap drives
44
SATA backplane activity LEDs for hot-swap
drives 19
scanning order for adapters
50 security rope clip 61
Serial Advanced Technology Attachment (SATA)
hot-swap drives 44, 45 simple-swap
drives47 status LEDs for hot-swap drives 19
Serial Attached SCSI (SAS)
backplane
description 45
IDs for hot-swap drives 47 hot-
swap drives 44, 45
Serial Attached SCSI (SAS)/SATA activity
LEDs for hot-swap drives 19
backplane
activity LEDs for hot-swap drives 19
status LEDs for hot-swap drives 19
status LEDs for hot-swap drives 19
serial connector 21 serial
number 3
server

Index

configuration 67 installing options 23
 power features 21 specifications 7
 turning it off 22 working inside with the
 power on 31
 server , backup firmware starting
 74
 server components 23
 server controls and indicator on
 the front 15
 server shutdown 22 ServeRAID
 support 12

 Setup utility (*continued*)
 using 68
 shutting down the server 22 LSI Configuration program 81
 the boot manager program 73 simple-swap drives 47
 Simple-swap SATA drives the remote presence feature 78 cabling 49 the Setup utility 68 size 8
 Utility program
 software service and support 86 IBM Advanced Settings 83 specifications, server
 7 utility, Setup
 starting menu choices 68 the backup firmware 74 starting 68
 the Setup utility 68 using 68 statements and notices 7 static electricity
 31

static-sensitive devices, handling 31
 status LEDs 15
 support, web site 85
 switches specifications 7 on the system board 26
 system board installing 58 external connectors 28
 internal connectors 24
 LEDs 29
 option connectors 25 Wake on LAN feature
 web site

system board jumpers 26 publication ordering 85 system reliability guidelines 30 support 85 system
 specifications 7 support line, telephone numbers 86
 system-error LED 18
 systems management 10, 12 compatible options 30, 35 systems management tool
 IBM support 7
 IBM Systems Director 14

T

with the power on 31 tape drive, installing 40 telephone numbers 86
 temperature 7
 TOE 8
 trademarks 87 turning off the server 22
 integrated baseboard management controller 22
 two-piece bezel 62

ServeRAID-MR10i adapter
 installing 53
 ServeRAID-MR10is adapter
 installing 56
 ServerGuide features 75
 NOS installation 75 setup
 75 using 74 ServerGuide
 CD 4, 11
 serviceability features 13
 Setup utility
 menu choices 68 starting
 68
 using
 embedded hypervisor 77
 simple-swap drives 47
 the Setup utility 68 size 8

V

video
 connector 21
 virtual media key

W

22 switches and jumpers 26

 Web site
 30, 35 systems management tool
 ServerProven list 30, 35, 49
 weight 7, 8
 working inside the server

U

- United States electronic emission Class A notice 90
- United States FCC Class A notice 90
- Universal Serial Bus (USB)
 - connectors front 19 rear 21
- UpdateXpress System Packs 15
- updating
 - IBM Systems Director 84
 - Systems Director, IBM 84
- upper bezel installing 62
- removing 34 user password 72

Index

Part Number: 81Y5703

Printed in USA

(1P) P/N: 81Y5703

