

System x iDataPlex dx360 M2
Types 6313, 6380, 6385, 6386,
7321, 7323, 7831, and 7834



User's Guide

System x iDataPlex dx360 M2
Types 6313, 6380, 6385, 6386,
7321, 7323, 7831, and 7834



User's Guide

Note: Before using this information and the product it supports, read the general information in Appendix B, "Notices," on page 71, the *Environmental Notices and User's Guide*, and the *Warranty and Support Information* document on the IBM *Documentation CD*.

Third Edition (January 2010)

© Copyright International Business Machines Corporation 2010.

US Government Users Restricted Rights – Use, duplication or disclosure restricted by GSA ADP Schedule Contract with IBM Corp.

Contents

Safety	vii
Chapter 1. Introduction	1
Related documentation	2
The IBM Documentation CD	3
Hardware and software requirements	3
Using the Documentation Browser	3
Notices and statements in this document	4
Features and specifications	5
What your dx360 M2 system-board tray offers	6
Reliability, availability, and serviceability	8
IBM Systems Director	8
The UpdateXpress System Packs	9
Chapter 2. Components, features, and controls	11
System-board tray components	12
System-board connectors	13
System-board jumpers	14
Flexible chassis features	15
Hardware configuration examples	17
2U compute server	17
2U input/output server	18
2U storage server	18
3U storage server	19
Operator panel controls, connectors, LEDs, and power	19
Front view	19
Rear view	21
Turning on the system-board tray	21
Turning off the system-board tray	21
Chapter 3. Installing optional devices	23
Installation guidelines	23
System reliability guidelines	23
Handling static-sensitive devices	24
Removing a 3U chassis from an iDataPlex rack	24
Removing a system-board tray from a 2U chassis	25
Removing a system-board tray from a 3U chassis	27
Removing the system-board tray cover	28
Removing an expansion enclosure	29
Removing a hard disk drive	30
Removing a 3.5-inch hot-swap hard disk drive	30
Removing a 3.5-inch simple-swap hard disk drive	30
Removing a 2.5-inch hot-swap hard disk drive	31
Removing a 2.5-inch simple-swap hard disk drive or solid-state drive	32
Installing an adapter	32
Installing an adapter in a one-slot riser card	33
Installing an adapter in a two-slot riser card	35
Installing a hard disk drive	36
Installing a 3.5-inch hot-swap hard disk drive	36
Installing a 3.5-inch simple-swap hard disk drive	37
Installing a 2.5-inch hot-swap hard disk drive	38
Installing a 2.5-inch simple-swap hard disk drive or solid-state drive	39
Installing a memory module	40

Installing an IBM virtual media key	44
Completing the installation	45
Reinstalling the system-board tray cover	45
Reinstalling an expansion enclosure	46
Reinstalling a system-board tray in a 2U chassis	47
Reinstalling a system-board tray in a 3U chassis	48
Reinstalling a 3U chassis in an iDataPlex rack	50
Connecting the cables	51
Updating the server configuration	51
Chapter 4. Configuring the dx360 M2 server	53
Using the Setup utility	54
Starting the Setup utility	55
Setup utility menu choices	55
Passwords	58
Using the Boot Menu program	59
Starting the backup UEFI firmware	59
Using the integrated management module	59
Using the remote presence capability and blue-screen capture	60
Enabling the remote presence feature	61
Obtaining the IP address for the Web interface access	61
Logging on to the Web interface	62
IBM Advanced Settings Utility program	62
Configuring the Gigabit Ethernet controller	63
Using the LSI Logic Configuration Utility program	63
Starting the LSI Logic Configuration Utility program	64
Formatting a SCSI hard disk drive	65
Creating a mirrored pair of SCSI hard disk drives	65
Configuring a ServeRAID controller	65
Firmware updates	66
Updating IBM Systems Director	67
Appendix A. Getting help and technical assistance	69
Before you call	69
Using the documentation	69
Getting help and information from the World Wide Web	70
Software service and support	70
Hardware service and support	70
IBM Taiwan product service	70
Appendix B. Notices	71
Trademarks	71
Important notes	72
German Ordinance for Work gloss statement	73
Electronic emission notices	73
Federal Communications Commission (FCC) statement	73
Industry Canada Class A emission compliance statement	73
Avis de conformité à la réglementation d'Industrie Canada	73
Australia and New Zealand Class A statement	73
United Kingdom telecommunications safety requirement	73
European Union EMC Directive conformance statement	74
Taiwanese Class A warning statement	74
Chinese Class A warning statement	74
Japanese Voluntary Control Council for Interference (VCCI) statement	75
Korean Class A warning statement	75

Index 77

Safety

Before installing this product, read the Safety Information.

قبل تركيب هذا المنتج، يجب قراءة الملاحظات الأمنية

Antes de instalar este produto, leia as Informações de Segurança.

在安装本产品之前，请仔细阅读 **Safety Information** (安全信息)。

安裝本產品之前，請先閱讀「安全資訊」。

Prije instalacije ovog produkta obavezno pročitajte Sigurnosne Upute.

Před instalací tohoto produktu si přečtěte příručku bezpečnostních instrukcí.

Læs sikkerhedsforskrifterne, før du installerer dette produkt.

Lees voordat u dit product installeert eerst de veiligheidsvoorschriften.

Ennen kuin asennat tämän tuotteen, lue turvaohjeet kohdasta Safety Information.

Avant d'installer ce produit, lisez les consignes de sécurité.

Vor der Installation dieses Produkts die Sicherheitshinweise lesen.

Πριν εγκαταστήσετε το προϊόν αυτό, διαβάστε τις πληροφορίες ασφάλειας (safety information).

לפני שתתקינו מוצר זה, קראו את הוראות הבטיחות.

A termék telepítése előtt olvassa el a Biztonsági előírásokat!

Prima di installare questo prodotto, leggere le Informazioni sulla Sicurezza.

製品の設置の前に、安全情報をお読みください。

본 제품을 설치하기 전에 안전 정보를 읽으십시오.

Пред да се инсталира овој продукт, прочитајте информацијата за безбедност.

Les sikkerhetsinformasjonen (Safety Information) før du installerer dette produktet.

Przed zainstalowaniem tego produktu, należy zapoznać się z książką "Informacje dotyczące bezpieczeństwa" (Safety Information).

Antes de instalar este produto, leia as Informações sobre Segurança.

Перед установкой продукта прочтите инструкции по технике безопасности.

Pred inštaláciou tohto zariadenia si pečítajte Bezpečnostné predpisy.

Pred namestitvijo tega proizvoda preberite Varnostne informacije.

Antes de instalar este producto, lea la información de seguridad.

Läs säkerhetsinformationen innan du installerar den här produkten.

Statement 1:



DANGER

Electrical current from power, telephone, and communication cables is hazardous.

To avoid a shock hazard:

- **Do not connect or disconnect any cables or perform installation, maintenance, or reconfiguration of this product during an electrical storm.**
- **Connect all power cords to a properly wired and grounded electrical outlet.**
- **Connect to properly wired outlets any equipment that will be attached to this product.**
- **When possible, use one hand only to connect or disconnect signal cables.**
- **Never turn on any equipment when there is evidence of fire, water, or structural damage.**
- **Disconnect the attached power cords, telecommunications systems, networks, and modems before you open the device covers, unless instructed otherwise in the installation and configuration procedures.**
- **Connect and disconnect cables as described in the following table when installing, moving, or opening covers on this product or attached devices.**

To Connect:

1. Turn everything OFF.
2. First, attach all cables to devices.
3. Attach signal cables to connectors.
4. Attach power cords to outlet.
5. Turn device ON.

To Disconnect:

1. Turn everything OFF.
2. First, remove power cords from outlet.
3. Remove signal cables from connectors.
4. Remove all cables from devices.

Statement 2:



CAUTION:

When replacing the lithium battery, use only IBM Part Number 33F8354 or an equivalent type battery recommended by the manufacturer. If your system has a module containing a lithium battery, replace it only with the same module type made by the same manufacturer. The battery contains lithium and can explode if not properly used, handled, or disposed of.

Do not:

- Throw or immerse into water
- Heat to more than 100°C (212°F)
- Repair or disassemble

Dispose of the battery as required by local ordinances or regulations.

Statement 3:



CAUTION:

When laser products (such as CD-ROMs, DVD drives, fiber optic devices, or transmitters) are installed, note the following:

- Do not remove the covers. Removing the covers of the laser product could result in exposure to hazardous laser radiation. There are no serviceable parts inside the device.
- Use of controls or adjustments or performance of procedures other than those specified herein might result in hazardous radiation exposure.



DANGER

Some laser products contain an embedded Class 3A or Class 3B laser diode. Note the following.

Laser radiation when open. Do not stare into the beam, do not view directly with optical instruments, and avoid direct exposure to the beam.

Statement 4:

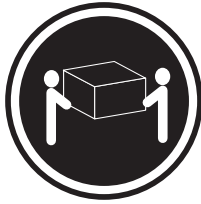

≥ 18 kg (39.7 lb)



≥ 32 kg (70.5 lb)

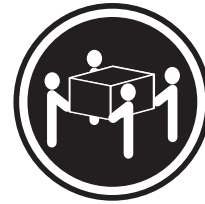

≥ 55 kg (121.2 lb)

CAUTION:

Use safe practices when lifting.

Statement 5:



CAUTION:

The power control button on the device and the power switch on the power supply do not turn off the electrical current supplied to the device. The device also might have more than one power cord. To remove all electrical current from the device, ensure that all power cords are disconnected from the power source.

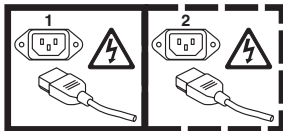

Statement 8:



CAUTION:

Never remove the cover on a power supply or any part that has the following label attached.



Hazardous voltage, current, and energy levels are present inside any component that has this label attached. There are no serviceable parts inside these components. If you suspect a problem with one of these parts, contact a service technician.

Statement 10:



CAUTION:

Do not place any object on top of rack-mounted devices.



Chapter 1. Introduction

IBM® System x™ iDataPlex™ products are ideally suited for data-center environments that require high-performance, energy-efficient, cost-effective hardware. The modular design of the iDataPlex components makes it possible for you to order customized server solutions that meet the specific needs of your current environment.

This *User's Guide* contains general information about how to use, upgrade, and configure the components in your customized server solution. These components consist of the IBM System x iDataPlex dx360 M2 system-board tray (dx360 M2 Type 6380, 7321, and 7323 system-board tray), an IBM System x iDataPlex 2U Flex Chassis (Type 6313, 6385, and 7831 2U chassis) or an IBM System x iDataPlex 3U Chassis (Type 6386 and 7834 3U chassis), the IBM System x iDataPlex Storage enclosure (storage enclosure), and the IBM System x iDataPlex I/O enclosure (I/O enclosure).

Depending on what you ordered, you received one or more of the following server solutions:

- Two dx360 M2 system-board trays installed in a 2U chassis
- One dx360 M2 system-board tray and one storage enclosure installed in a 2U chassis
- One dx360 M2 system-board tray and one I/O enclosure installed in a 2U chassis
- One dx360 M2 system-board tray installed in a 3U chassis

See Chapter 2, “Components, features, and controls,” on page 11 for detailed information about the components in the customized server solutions.

The iDataPlex products come with a limited warranty. For information about the terms of the warranty and getting service and assistance, see the *Warranty and Support Information* document.

You can obtain up-to-date information about the IBM iDataPlex products and other IBM server products at <http://www.ibm.com/systems/x/>.

If you participate in the IBM client reference program, you can share information about your use of technology, best practices, and innovative solutions; build a professional network; and gain visibility for your business. For more information about the IBM client reference program, see <http://www.ibm.com/ibm/clientreference/>.

At <http://www.ibm.com/support/mysupport/>, you can create a personalized support page by identifying IBM products that are of interest to you. From this personalized page, you can subscribe to weekly e-mail notifications about new technical documents, search for information and downloads, and access various administrative services.

The system-board tray serial number is on a label at the front of the system-board tray. The system-board tray integrated management module (IMM) media access control (MAC) address is on a tab at the right side of the system-board tray. The chassis machine type and serial number are on a label on the front of the chassis at the right side.

Label locations are shown in the illustration following the table. This illustration might differ slightly from your hardware.

Record information about the server in the following table.

Product name	IBM System x iDataPlex dx360 M2
Machine type (system-board tray)	Type 6380, 7321, or 7323
Serial number (system-board tray)	_____
IMM MAC address (system-board tray)	_____
Machine type (chassis)	Type 6313, 6385, or 7831 (2U chassis) or Type 6386 or 7834 (3U chassis)
Serial number (chassis)	_____

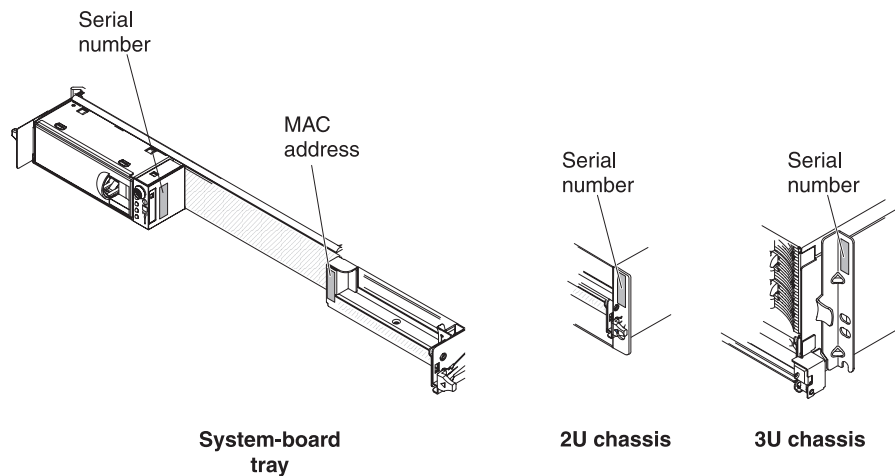

Related documentation

In addition to the printed *Important Notices* document and this *User's Guide*, the following documentation for the dx360 M2 system-board tray, 2U chassis, and 3U chassis is provided in Portable Document Format (PDF) on the IBM *Documentation CD*:

- *Environmental Notices and User's Guide*
This document is in PDF on the IBM *Documentation CD*. It contains translated environmental notices.
- *Problem Determination and Service Guide*
This document contains information to help you solve problems yourself, and it contains information for service technicians.
- *Safety Information*
This document contains translated caution and danger statements. Each caution and danger statement that appears in the documentation has a number that you can use to locate the corresponding statement in your language in the *Safety Information* document.
- *Warranty and Support Information*
This document contains information about the terms of the warranty and getting service and assistance.

Depending on the hardware configuration, additional documentation might be included on the IBM *Documentation CD*.

The iDataPlex documentation might be updated occasionally, or technical updates might be available to provide additional information that is not included in the documentation. These updates are available from the IBM Systems Information Center. To check for updated iDataPlex information and technical updates, go to <http://publib.boulder.ibm.com/infocenter/idadaplx/documentation/index.jsp>.

The updated iDataPlex documentation also is available from the IBM Support Web site. To check for updated documentation and technical updates, complete the following steps.

Note: Changes are made periodically to the IBM Web site. The actual procedure might vary slightly from what is described in this document.

1. Go to <http://www.ibm.com/systems/support/>.
2. Under **Product support**, click **System x**.
3. Under **Popular links**, click **Publications lookup**.
4. From the **Product family** menu, select **System x iDataPlex dx360 M2 server** and click **Go**.

The IBM Documentation CD

The IBM *Documentation CD* contains documentation in Portable Document Format (PDF) and includes the IBM Documentation Browser to help you find information quickly.

Hardware and software requirements

The IBM *Documentation CD* requires the following minimum hardware and software:

- Microsoft® Windows® XP, Windows 2000, or Red Hat Linux®
- 100 MHz microprocessor
- 32 MB of RAM
- Adobe® Acrobat Reader 3.0 (or later) or xpdf, which comes with Linux operating systems

Using the Documentation Browser

Use the Documentation Browser to browse the contents of the CD, read brief descriptions of the documents, and view documents, using Adobe Acrobat Reader or xpdf. The Documentation Browser automatically detects the regional settings in your server and displays the documents in the language for that region (if available). If a document is not available in the language for that region, the English-language version is displayed.

Use one of the following procedures to start the Documentation Browser:

- If Autostart is enabled, insert the CD into the CD or DVD drive. The Documentation Browser starts automatically.
- If Autostart is disabled or is not enabled for all users, use one of the following procedures:
 - If you are using a Windows operating system, insert the CD into the CD or DVD drive and click **Start --> Run**. In the **Open** field, type
`e:\win32.bat`

- where *e* is the drive letter of the CD or DVD drive, and click **OK**.
- If you are using Red Hat Linux, insert the CD into the CD or DVD drive; then, run the following command from the `/mnt/cdrom` directory:

```
sh runlinux.sh
```

Select the device from the **Product** menu. The **Available Topics** list displays all the documents for the devices. Some documents might be in folders. A plus sign (+) indicates each folder or document that has additional documents under it. Click the plus sign to display the additional documents.

When you select a document, a description of the document is displayed under **Topic Description**. To select more than one document, press and hold the Ctrl key while you select the documents. Click **View Book** to view the selected document or documents in Acrobat Reader or xpdf. If you selected more than one document, all the selected documents are opened in Acrobat Reader or xpdf.

To search all the documents, type a word or word string in the **Search** field and click **Search**. The documents in which the word or word string appears are listed in order of the most occurrences. Click a document to view it, and press Ctrl+F to use the Acrobat search function, or press Alt+F to use the xpdf search function within the document.

Click **Help** for detailed information about using the Documentation Browser.

Notices and statements in this document

The caution and danger statements in this document are also in the multilingual *Safety Information* document, which is on the IBM *Documentation* CD. Each statement is numbered for reference to the corresponding statement in your language in the *Safety Information* document.

The following notices and statements are used in this document:

- **Note:** These notices provide important tips, guidance, or advice.
- **Important:** These notices provide information or advice that might help you avoid inconvenient or problem situations.
- **Attention:** These notices indicate potential damage to programs, devices, or data. An attention notice is placed just before the instruction or situation in which damage might occur.
- **Caution:** These statements indicate situations that can be potentially hazardous to you. A caution statement is placed just before the description of a potentially hazardous procedure step or situation.
- **Danger:** These statements indicate situations that can be potentially lethal or extremely hazardous to you. A danger statement is placed just before the description of a potentially lethal or extremely hazardous procedure step or situation.

Features and specifications

The following information is a summary of the features and specifications of the hardware. Depending on the hardware configuration, some features might not be available, or some specifications might not apply.

Racks are marked in vertical increments of 4.45 cm (1.75 inches). Each increment is referred to as a unit, or “U.” A 1U-high device is 1.75 inches tall.

<p>Microprocessor: One or two quad-core Intel® Xeon® microprocessors with integrated memory controllers in each system-board tray</p> <p>Note: Use the Setup utility to determine the type and speed of the microprocessor.</p> <p>Hard disk drives: The system-board tray supports one 3.5-inch simple-swap SAS (with the optional SAS controller), one 3.5-inch simple-swap SATA, or two 2.5-inch simple-swap SATA hard disk drives or solid-state drives. The system-board tray with an attached enclosure can support the following drive configurations:</p> <ul style="list-style-type: none"> Up to four 3.5-inch simple-swap SAS or SATA hard disk drives with the storage enclosure and optional SAS controller Up to five 3.5-inch simple-swap SATA hard disk drives with the storage enclosure Up to two 3.5-inch simple-swap SATA hard disk drives with the I/O enclosure Up to two 2.5-inch simple-swap SAS hard disk drives and four 3.5-inch simple-swap SAS hard disk drives with the I/O enclosure Up to two 3.5-inch simple-swap SAS hard disk drives with the I/O enclosure and optional SAS controller Up to eight 2.5-inch hot-swap SAS hard disk drives with the I/O enclosure and optional SAS controller Up to twelve 3.5-inch hot-swap SAS or SATA (with the optional SAS controller) hard disk drives in a 3U chassis 	<p>Memory:</p> <ul style="list-style-type: none"> Sixteen DIMM connectors (eight per microprocessor) Minimum: Two DIMMs per microprocessor Maximum: 64 GB (as of the date of this publication) Type: Registered ECC double-data-rate 3 (DDR3) -800, -1066, and -1333 MHz DIMMs only Sizes: 1 GB single-rank, 2 GB dual-rank, and 4 GB dual-rank Chipkill supported with selected DIMMs <p>Integrated functions:</p> <ul style="list-style-type: none"> Integrated management module (IMM), which provides service processor control and monitoring functions, video controller, and (when the optional virtual media key is installed) remote keyboard, video, mouse, and remote hard disk drive capabilities Dedicated or shared management network connections Six Serial ATA (SATA) ports Serial over LAN (SOL) and serial redirection over Telnet or Secure Shell (SSH) Dual-port Gigabit Ethernet controller Front connectors for USB 2.0 (2 ports), serial, video, and RJ-45 (3 ports) <ul style="list-style-type: none"> One systems-management RJ-45 port for connection to a dedicated systems-management network Two RJ-45 LAN ports <p>Predictive Failure Analysis (PFA) alerts:</p> <ul style="list-style-type: none"> Memory Hard disk drives 	<p>Expansion slots: Up to two PCI Express slots total. Support for the following riser cards:</p> <ul style="list-style-type: none"> One PCI Express x16 slot (x16) Two PCI Express x16 slots (x8) One PCI Express x8 slot (x8) supports an optional RAID controller only (some configurations) <p>Environment:</p> <ul style="list-style-type: none"> Air temperature: <ul style="list-style-type: none"> Server on: 10°C to 35°C (50°F to 95°F); altitude: 0 to 914.4 m (0 to 3000 ft). Derate maximum temperature by 1°C for every 304.8 m (1000 ft) increase in elevation to a maximum of 3048.0 m (10000 ft) at an ambient temperature of 28°C Server off: 10°C to 43°C (59°F to 109.4°F); maximum altitude: 2133 m (7000 ft) Humidity: <ul style="list-style-type: none"> Server on: 10% to 80% Server off: 8% to 80% <p>Size:</p> <ul style="list-style-type: none"> Height: <ul style="list-style-type: none"> 2U chassis: 8.6 cm (3.39 inches) 3U chassis: 13.0 cm (5.1 inches) Depth: 51.3 cm (20.2 inches) Width: 44.6 cm (17.6 inches) Weight: <ul style="list-style-type: none"> 2U chassis: <ul style="list-style-type: none"> Fully loaded: 22.7 kg (46.1 lb) Without system-board trays: 7.1 kg (15.6 lb) 3U chassis: <ul style="list-style-type: none"> Fully loaded: 28.1 kg (62.0 lb) Without hard disk drives: 15.4 kg (34.0 lb) <p>Electrical Input:</p> <ul style="list-style-type: none"> Input voltage low range: 100 V ac (minimum) to 127 V ac (maximum), sine-wave input (50 - 60 Hz) Input voltage high range: 200 V ac (minimum) to 240 V ac (maximum), sine-wave input (50 - 60 Hz)
---	--	--

What your dx360 M2 system-board tray offers

The dx360 M2 system-board tray uses the following features and technologies:

- **Active PCI Express x16 Generation 2 adapter capabilities**

The dx360 M2 system-board tray has up to three connectors for PCI Express adapters on up to two riser cards. These connectors accept x16 adapters.

- **Dynamic System Analysis (DSA) programs**

The DSA programs collect and analyze system information to aid in diagnosing problems. The diagnostic programs collect the following information:

- System configuration
- Network interfaces and settings
- Installed hardware
- Service processor status and configuration
- Vital product data, firmware, and Unified Extensible Firmware Interface (UEFI) configuration
- Hard disk drive health
- RAID controller configuration
- Event logs for ServeRAID controllers and service processors

The diagnostic programs create a merged log that includes events from all collected logs. The information is collected into a file that you can send to IBM service and support. Additionally, you can view the information locally through a generated text report file. You can also copy the log to removable media and view the log from a Web browser.

- **Integrated management module**

The integrated management module (IMM) combines service processor functions, video controller, and (when an optional virtual media key is installed) remote presence function in a single chip. The IMM provides advanced service-processor control, monitoring, and alerting function. If an environmental condition exceeds a threshold or if a system component fails, the IMM lights LEDs to help you diagnose the problem, records the error in the event log, and alerts you to the problem. Optionally, the IMM also provides a virtual presence capability for remote server management capabilities. The IMM provides remote server management through industry-standard interfaces:

- Intelligent Platform Management Interface (IPMI) version 2.0
- Simple Network Management Protocol (SNMP) version 3
- Common Information Model (CIM)
- Web browser

- **Integrated network support**

The dx360 M2 system-board tray comes with an integrated Intel dual-port Gigabit Ethernet controller, which supports connection to a 10 Mbps, 100 Mbps, or 1000 Mbps network. For more information, see “Configuring the Gigabit Ethernet controller” on page 63.

- **Large data-storage capacity and hot-swap capability**

The dx360 M2 system-board tray supports one 3.5-inch simple-swap SAS, one 3.5-inch simple-swap SATA, or two 2.5-inch simple-swap SATA hard disk drives or solid-state drives. An optional SAS controller must be installed when you use SAS hard disk drives.

With the storage enclosure attached, the system-board tray can support up to four 3.5-inch simple-swap SAS (with optional SAS controller) hard disk drives or five simple-swap SATA hard disk drives.

With the I/O enclosure attached, the system-board tray can support up to two 3.5-inch simple-swap SATA hard disk drives, up to two 3.5-inch simple-swap SAS hard disk drives (with optional SAS controller), or up to eight 2.5-inch hot-swap SAS hard disk drives (with optional SAS controller).

When it is installed in a 3U chassis, the system-board tray can support up to twelve 3.5-inch hot-swap SAS (with optional SAS controller) or SATA hard disk drives. With the hot-swap feature, you can remove or replace hard disk drives without turning off the dx360 M2 server.

- **Large system-memory capacity**

The dx360 M2 system-board tray supports up to 64 GB of system memory (as of the date of this publication). The memory controller supports up to 16 industry-standard, registered ECC double-data-rate 3 (DDR3) -800, -1066, and -1333 MHz DIMMs.

- **Redundant connection**

The addition of an optional network interface card (NIC) provides a failover capability to a redundant Ethernet connection. If a problem occurs with the primary Ethernet connection, all Ethernet traffic that is associated with the primary connection is automatically switched to the redundant NIC. If the applicable device drivers are installed, this switching occurs without data loss and without user intervention.

- **Remote presence capability and blue-screen capture**

The optional virtual media key is required to enable the remote presence and blue-screen capture features. The remote presence feature provides the following functions:

- Remotely viewing video with graphics resolutions up to 1280 x 1024 at 75 Hz, regardless of the system state
- Remotely accessing the server, using the keyboard and mouse from a remote client
- Mapping the CD or DVD drive, diskette drive, and USB flash drive on a remote client, and mapping ISO and diskette image files as virtual drives that are available for use by the server
- Uploading a diskette image to the IMM memory and mapping it to the server as a virtual drive

The blue-screen capture feature captures the video display contents before the IMM restarts the server when the IMM detects an operating-system hang condition. A system administrator can use the blue-screen capture to assist in determining the cause of the hang condition.

- **ServeRAID support**

The dx360 M2 system-board tray supports ServeRAID adapters to create redundant array of independent disks (RAID) configurations.

- **Symmetric multiprocessing (SMP)**

The dx360 M2 system-board tray comes with one or two Intel microprocessors. If the system-board tray comes with only one microprocessor, a trained service technician can add a second microprocessor.

- **Systems-management capabilities**

The dx360 M2 system-board tray supports IPMI version 2.0 over LAN systems-management protocol. It supports an optional rack-level management controller that uses industry-standard management tools.

Reliability, availability, and serviceability

Three important hardware and software design features are reliability, availability, and serviceability (RAS). The RAS features help to ensure the integrity of the data that is stored in the hardware, the availability of the hardware and software when you need it, and the ease with which you can diagnose and correct problems.

The dx360 M2 has the following RAS features:

- Advanced Configuration and Power Interface (ACPI)
- Advanced Desktop Management Interface (DMI) features
- Automatic error retry or recovery
- Automatic restart after a power failure, based on the UEFI setting
- Built in, menu-driven setup, system configuration, and redundant array of independent disks (RAID) configuration (depending on server configuration)
- Built-in monitoring of fan, power, temperature, and voltage
- CD-based diagnostic programs
- Customer support center that is available 24 hours a day, 7 days a week¹
- Diagnostic support of ServeRAID adapters
- Error codes and messages
- Hot-swap Serial Attached SCSI (SAS) hard disk drives (some configurations)
- Integrated Ethernet controller
- Integrated management module (IMM)
- Power-on self-test (POST) with error logging of POST failures
- Power management
- Read-only memory (ROM) checksums
- Redundant Ethernet capabilities with failover support
- Remote system problem-determination support
- Simple-swap Serial Advanced Technology Attachment (SATA) hard disk drives (some configurations)
- Simple-swap Serial Attached SCSI (SAS) hard disk drives (some configurations)
- Standby voltage for systems-management features and monitoring
- Startup from backup UEFI page
- System-error LED on the front bezel
- System-error logging
- Upgradeable IMM firmware
- Upgradeable microcode for POST, UEFI code, and ROM resident code, locally or over a LAN
- Vital product data (VPD); includes firmware revision numbers, stored in nonvolatile memory, for easier remote maintenance

IBM Systems Director

IBM Systems Director is a platform-management foundation that streamlines the way you manage physical and virtual systems in a heterogeneous environment. By using industry standards, IBM Systems Director supports multiple operating systems and virtualization technologies in IBM and non-IBM x86 platforms.

1. Service availability will vary by country. Response time varies; may exclude holidays.

Through a single user interface, IBM Systems Director provides consistent views for viewing managed systems, determining how these systems relate to one another, and identifying their statuses, helping to correlate technical resources with business needs. A set of common tasks that are included with IBM Systems Director provides many of the core capabilities that are required for basic management, which means instant out-of-the-box business value. These common tasks include discovery, inventory, configuration, system health, monitoring, updates, event notification, and automation for managed systems.

The IBM Systems Director Web and command-line interfaces provide a consistent interface that is focused on driving these common tasks and capabilities:

- Discovering, navigating, and visualizing systems on the network with the detailed inventory and relationships to the other network resources
- Notifying users of problems that occur on systems and the ability to isolate the sources of the problems
- Notifying users when systems need updates and distributing and installing updates on a schedule
- Analyzing real-time data for systems and setting critical thresholds that notify the administrator of emerging problems
- Configuring settings of a single system and creating a configuration plan that can apply those settings to multiple systems
- Updating installed plug-ins to add new features and functions to the base capabilities
- Managing the life cycles of virtual resources

For more information about IBM Systems Director, see the documentation on the *IBM Systems Director* CD that comes with the server and the IBM xSeries® Systems Management Web page at <http://www.ibm.com/systems/management/>, which presents an overview of IBM Systems Management and IBM Systems Director.

The UpdateXpress System Packs

The UpdateXpress System Packs provide an effective and simple way to update device drivers, server firmware, and firmware of supported options contained within the server, for System x® and IBM BladeCenter® servers. Each UpdateXpress System Pack contains all the online driver and firmware updates for a specific machine type and operating system combination. The UpdateXpress System Packs are released quarterly. Use the UpdateXpress System Pack Installer to install the current UpdateXpress System Pack for your server.

Important: Some cluster solutions require specific code levels or coordinated code updates. If the device is part of a cluster solution, verify that the latest level of code is supported for the cluster solution before you update the code.

You can download the installer and the latest UpdateXpress System Pack for your server from the Web at no additional cost. To download the installer or the latest UpdateXpress System Pack, go to <http://www.ibm.com/systems/support/supportsite.wss/docdisplay?Indocid=SERV-XPRESS&brandind=5000008> or complete the following steps.

Note: Changes are made periodically to the IBM Web site. The actual procedure might vary slightly from what is described in this document.

1. Got to <http://www.ibm.com/systems/support/>.

2. Under **Product support**, click **System x**.
3. Under **Popular links**, click **Software and device drivers**.
4. Under **Related downloads**, click **UpdateXpress**.

Note: To install the *UpdateXpress* program, you might have to use an external USB CD-RW/DVD drive such as the IBM and Lenovo part number 73P4515 or 73P4516. See “Firmware updates” on page 66 for additional instructions about using an external USB CD-RW/DVD drive.

Chapter 2. Components, features, and controls

This section describes the server components and configurations, the server controls and light-emitting diodes (LEDs), and how to turn the system-board tray on and off.

System-board tray components

The following illustration shows the major components in the dx360 M2 system-board tray.

Note: The illustrations in this document might differ slightly from your hardware.

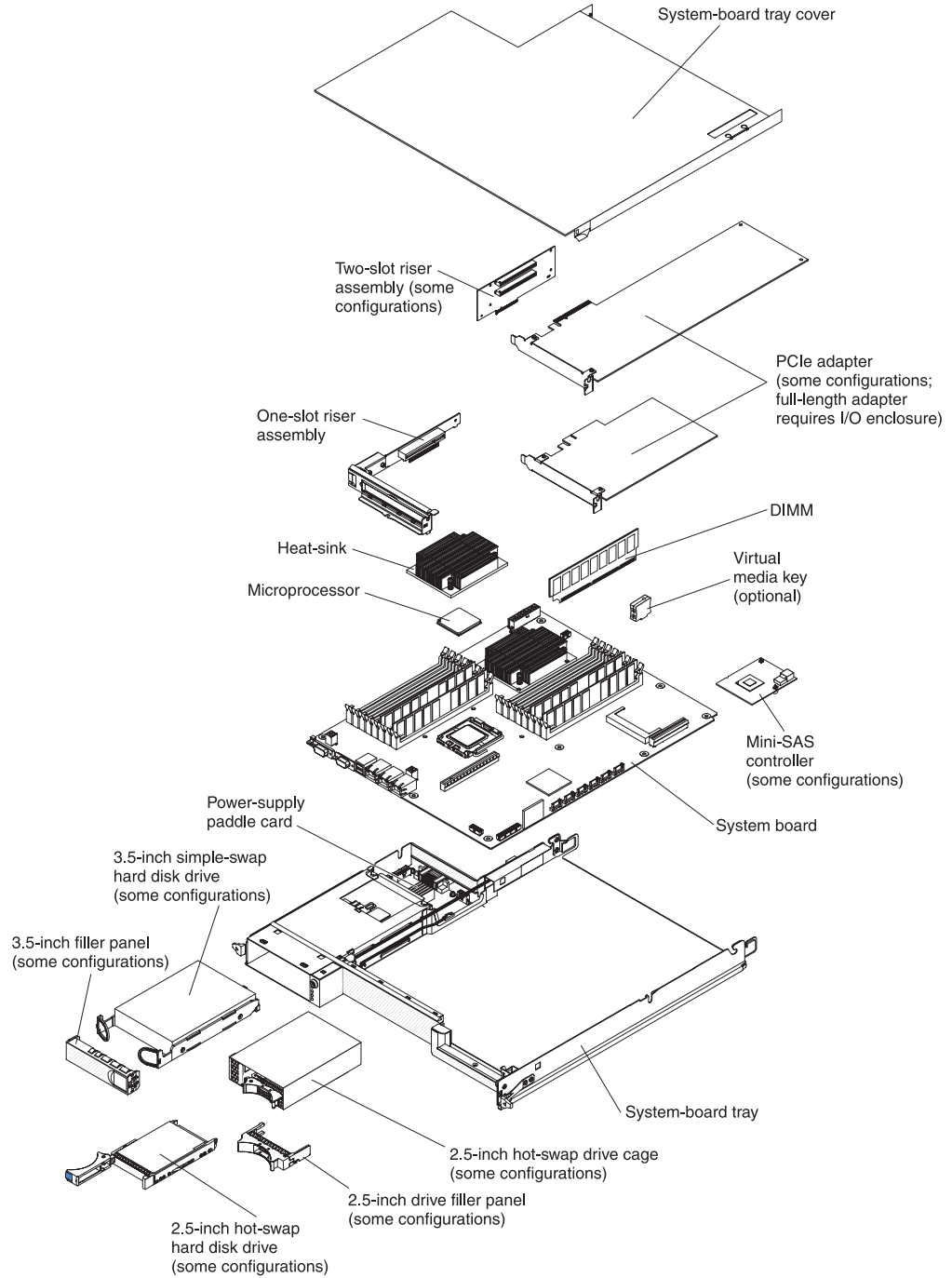

System-board connectors

The following illustration shows the locations of internal connectors on the system board that are used for installing optional devices. See “Operator panel controls, connectors, LEDs, and power” on page 19 for information about the external connectors. See the *Problem Determination and Service Guide* for information about the other system-board connectors.

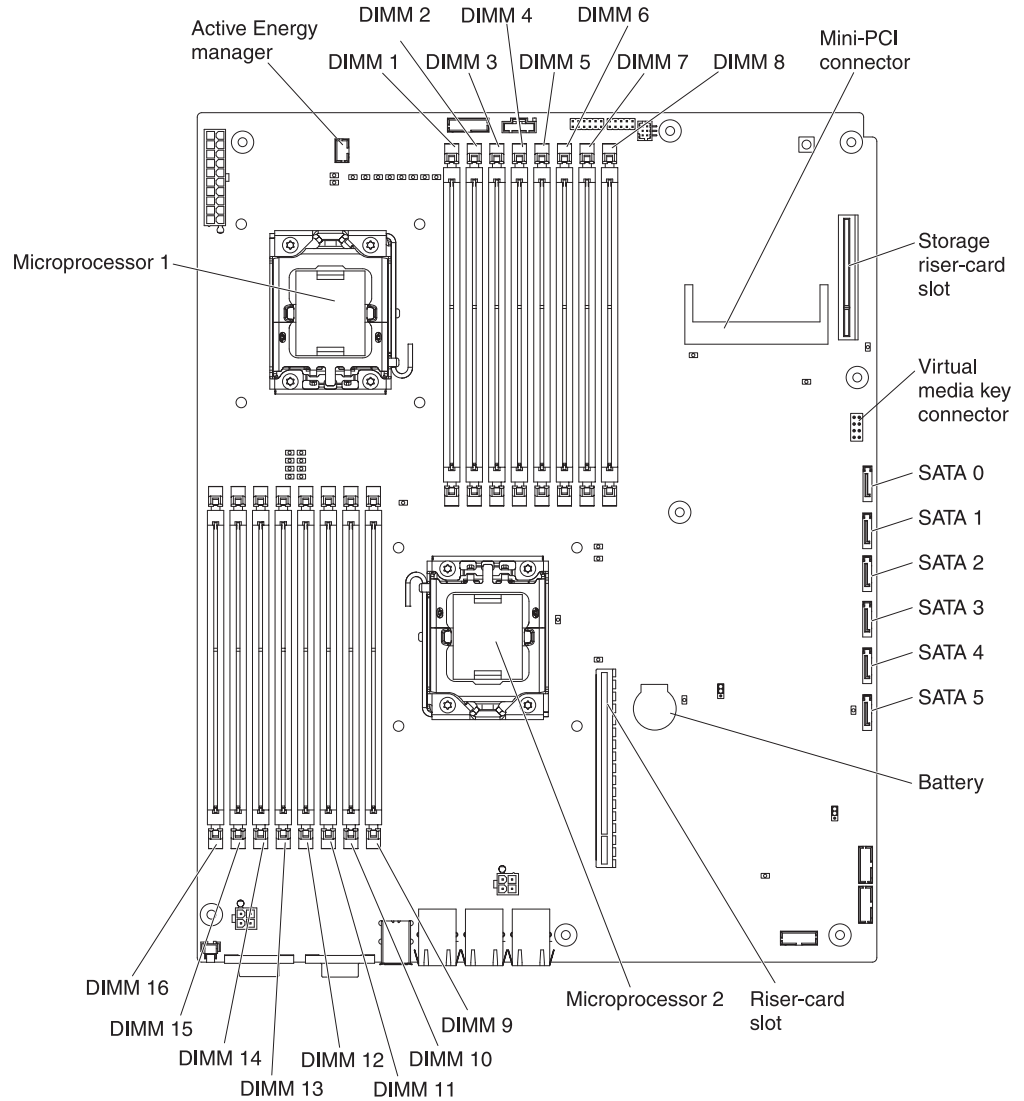

System-board jumpers

The following illustration shows the locations of the jumpers on the system board that relate to selected system functions. See the *Problem Determination and Service Guide* for more information about using jumpers on the system board.

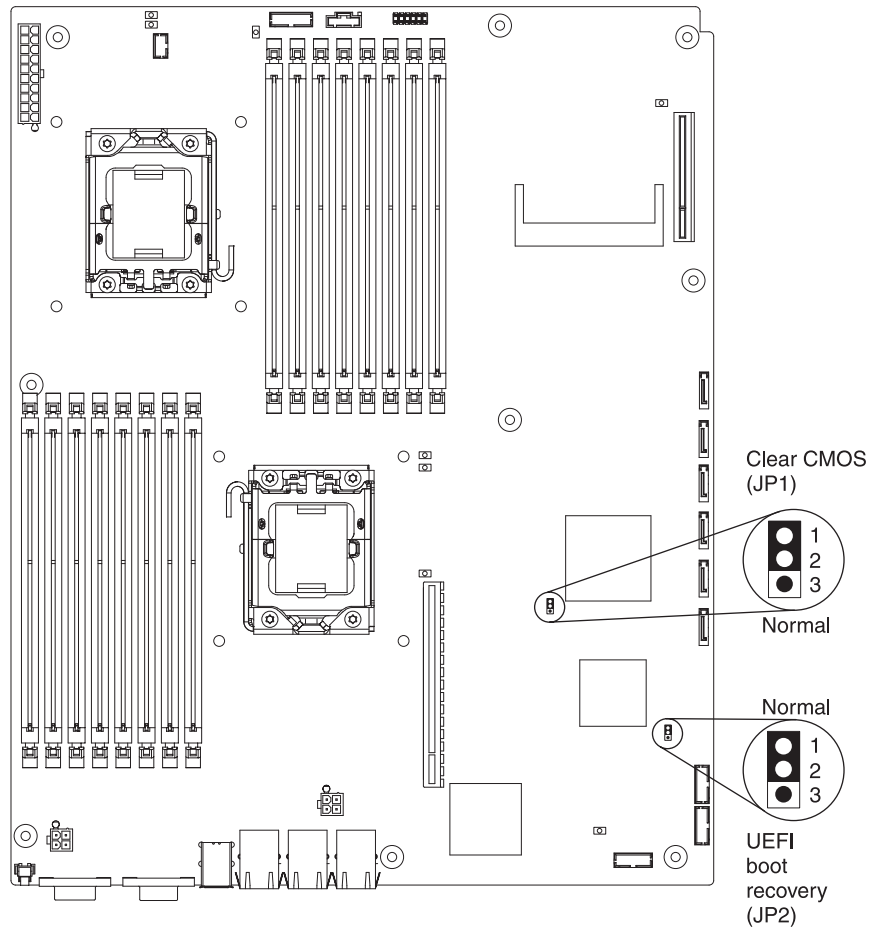

Flexible chassis features

Note: The illustrations in this document might differ slightly from your hardware.

The following illustration shows a 2U chassis. The 2U chassis contains a power supply and a fan assembly that provide operating power and cooling for all components in the chassis. The 2U chassis can support two system-board trays or one system-board tray with an expansion enclosure.

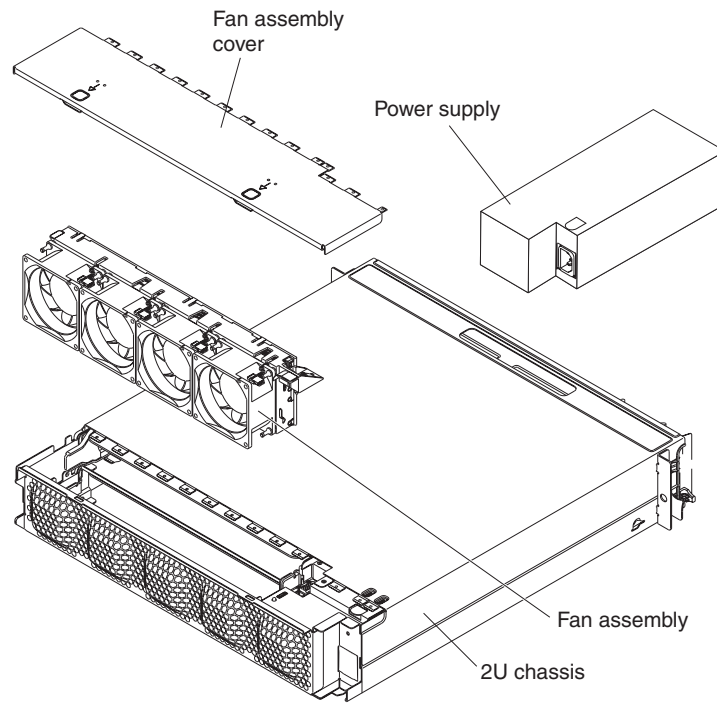

The following illustration shows a 3U chassis. The 3U chassis contains a power supply and a fan assembly that provide operating power and cooling for all components in the chassis. Depending on your server configuration, it also provides support for the installation of up to twelve 3.5-inch hot-swap SAS or SATA hard disk drives (SAS and SATA hard disk drives cannot be used within the same server). The 3U chassis supports one system-board tray that must contain a RAID adapter to control operation of these hard disk drives.

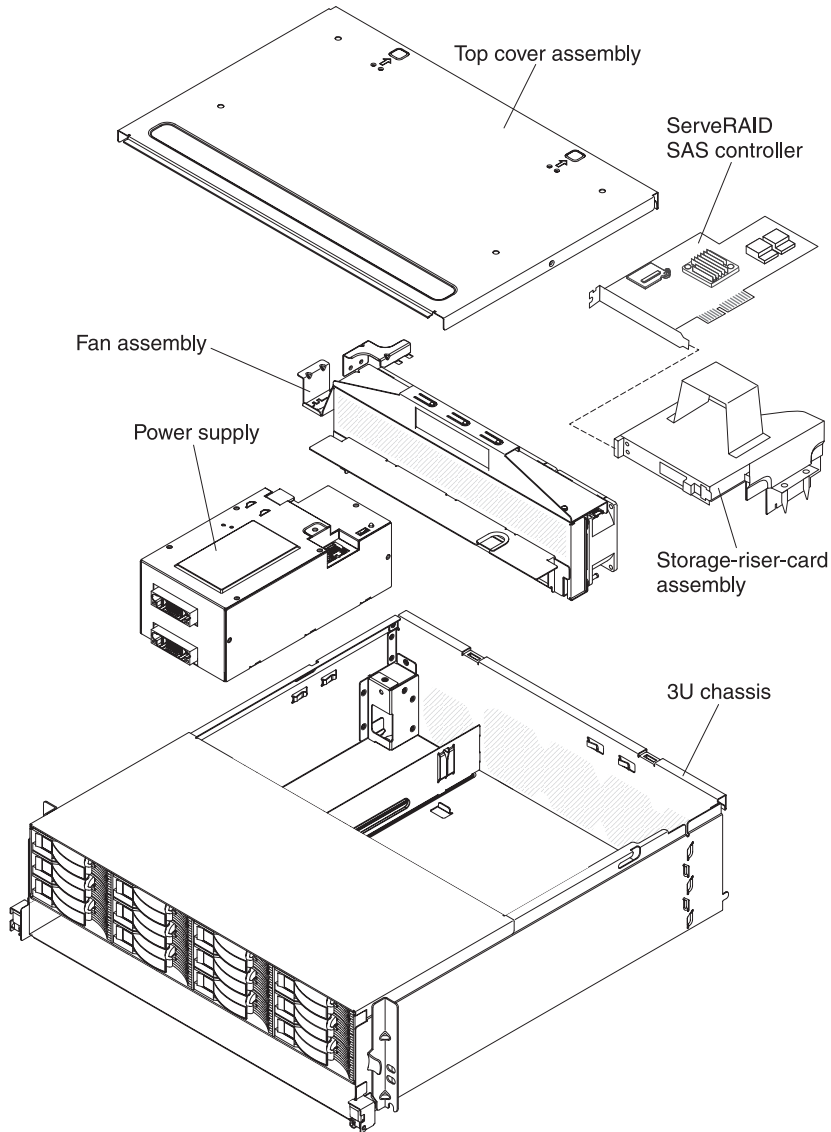

Hardware configuration examples

The 2U chassis and 3U chassis support the following iDataPlex dx360 M2 configurations:

- 2U compute server: a 2U chassis that contains two dx360 M2 system-board trays
- 2U input/output server: a 2U chassis that contains one dx360 M2 system-board tray and an optional I/O enclosure
- 2U storage server: a 2U chassis that contains one dx360 M2 system-board tray and an optional storage enclosure
- 3U storage server: a 3U chassis that contains one dx360 M2 system-board tray and integrated storage

Note: The illustrations in this document might differ slightly from your hardware.

2U compute server

The 2U compute server consists of two identical dx360 M2 system-board trays that are installed in a 2U chassis. Each system-board tray has one PCI adapter connector and one 3.5-inch hard disk drive bay that might be configured to hold two 2.5-inch hard disk drives or solid-state drives. The following illustration shows an installed 3.5-inch simple-swap SATA hard disk drive.

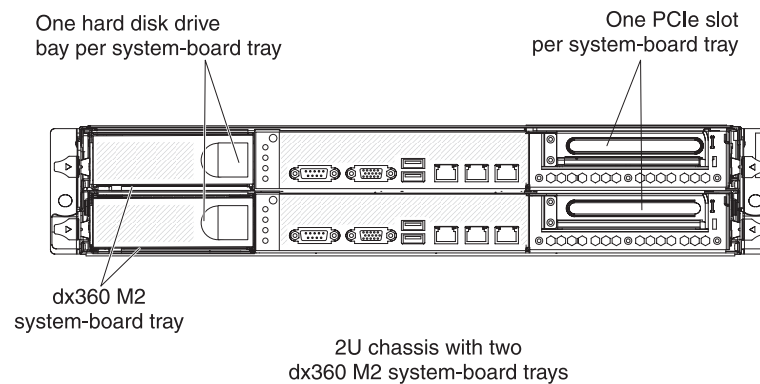

2U input/output server

The 2U input/output server consists of one dx360 M2 system-board tray with the I/O enclosure that is installed in a 2U chassis. The I/O enclosure provides one additional 3.5-inch hard disk bay or six additional 2.5-inch drive bays, and two PCIe slots for the system-board tray. You can configure the 2U input/output server with up to two 3.5-inch hard disk drives or up to eight 2.5-inch hard disk drives. The following illustration shows two installed 3.5-inch simple-swap SATA hard disk drives.

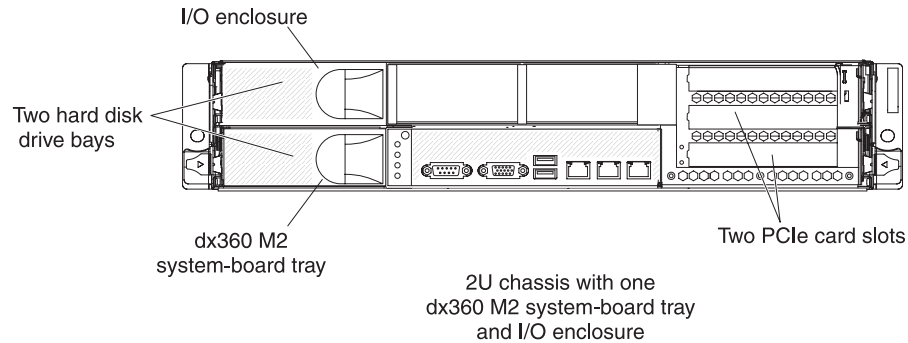

2U storage server

The 2U storage server consists of one dx360 M2 system-board tray with the storage enclosure that is installed in a 2U chassis. The storage enclosure provides four additional 3.5-inch hard disk drive bays for the system-board tray, for a total of five. Depending on the server configuration, you can configure the 2U storage server with up to four SAS 3.5-inch hard disk drives, up to five SATA 3.5-inch hard disk drives, or up to two 2.5-inch simple-swap SATA hard disk drives. The following illustration shows five installed 3.5-inch simple-swap SATA hard disk drives.

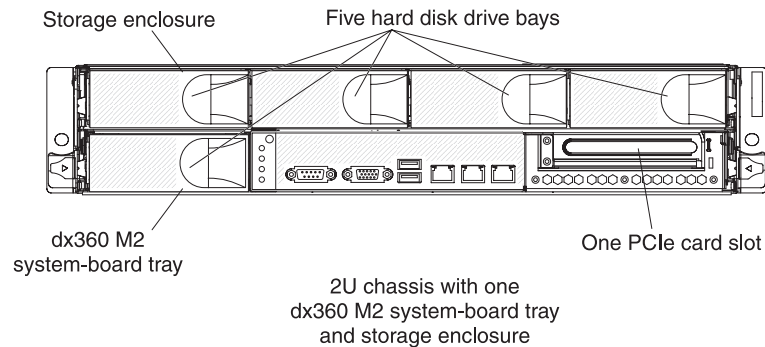

3U storage server

The 3U storage server consists of one dx360 M2 system-board tray that is installed in a 3U chassis. Depending on the server configuration, the 3U chassis supports up to twelve 3.5-inch hot-swap SAS or SATA hard disk drives. The following illustration shows twelve installed 3.5-inch hot-swap SAS hard disk drives.

Note: The hard disk drive bays in the system-board tray are not used in the 3U storage server configuration.

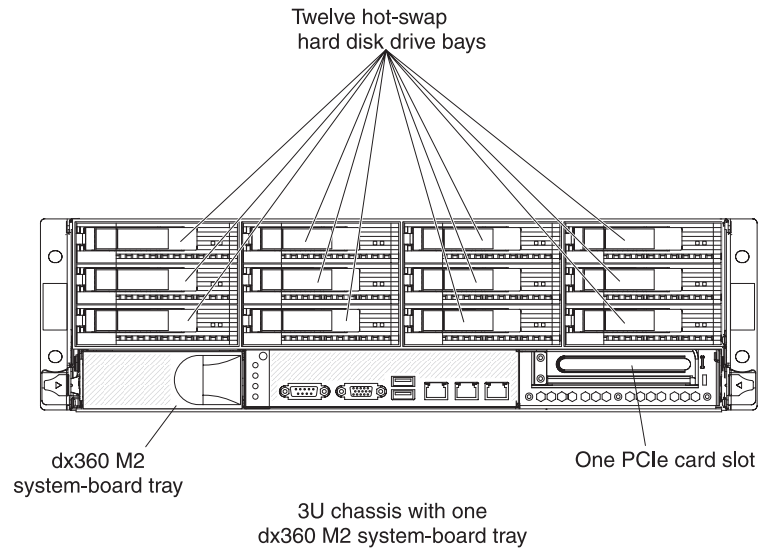

Operator panel controls, connectors, LEDs, and power

This section describes the controls, connectors, and light-emitting diodes (LEDs) and how to turn the system-board tray on and off.

Front view

The following illustration shows the controls, connectors, and LEDs on the front of the server. The operator panel on the system-board tray is the same for all server configurations.

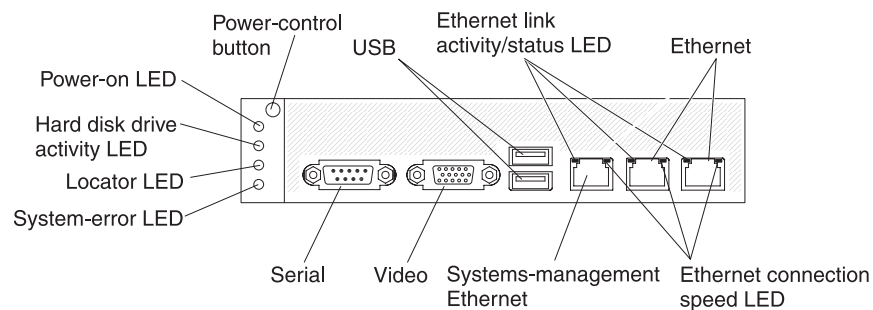

Power-control button: Press this button to turn the system-board tray on and off manually or to wake the system-board tray from a reduced-power state. Note that the power-control button is recessed to prevent the system-board tray from being turned on or off accidentally. There is a power-control button cover that can be removed for easier access to the power-control button.

USB connectors: Connect USB 2.0 devices to these connectors.

Ethernet link activity/status LED: This LED is on each Ethernet connector. When this LED is lit, it indicates that there is an active connection on the Ethernet port. When this LED is flashing, it indicates that there is activity between the server and the network.

Ethernet connectors: Use these connectors to connect the server to a network.

Ethernet connection speed LED: This LED is on each Ethernet connector. The status of this LED indicates the connection speed, in megabits-per-second (Mbps), between the server and the network as follows:

- LED off: 10 Mbps connection
- LED lit amber: 100 Mbps connection
- LED lit green: 1000 Mbps connection

Systems-management Ethernet connector: Use this connector to connect the server to a network for systems-management information control.

Video connector: Connect a monitor to this connector.

Serial connector: Connect a 9-pin serial device to this connector. The serial port is shared with the integrated management module (IMM). The IMM can take control of the shared serial port to perform text console redirection and to redirect serial traffic, using Serial over LAN (SOL).

System-error LED: When this LED is lit, it indicates that a system error has occurred. The source of the error is logged in the system-event log that is accessed in the Setup utility.

Locator LED: This LED can be lit remotely by the system administrator to aid in visually locating the system-board tray. In an IPMI environment, the system administrator can light the LED by using the IPMI **chassis identify** command.

Hard disk drive activity LED: When this LED is lit or flashing, it indicates that an associated hard disk drive is in use.

In configurations that contain hot-swap hard disk drives, each hot-swap hard disk drive has the following LEDs.

- **Hot-swap hard disk drive activity LED:** When this LED is flashing, it indicates that the drive is in use.
- **Hot-swap hard disk drive status LED:** When this LED is lit, it indicates that the drive has failed.

Power-on LED: The states of the power-on LED are as follows:

- **Off:** AC power is not present, or the power supply or the LED itself has failed.
- **Flashing rapidly (4 times per second):** The system-board tray is turned off and is not ready to be turned on. The power-control button is disabled.
- **Flashing slowly (once per second):** The system-board tray is turned off and is ready to be turned on. You can press the power-control button to turn on the system-board tray.
- **Lit:** The system-board tray is turned on.
- **Fading on and off:** The system-board tray is in a reduced-power state. To wake the system-board tray, press the power-control button or use the IMM Web interface.

Note: If this LED is off, it does not mean that no electrical power is present. The LED might be burned out. To remove all electrical power, you must remove the system-board tray from the chassis, remove the chassis from the rack, or disconnect the power cord from the power source.

Rear view

The following illustration shows the connector on the rear of the 2U chassis, the 3U chassis is similar.

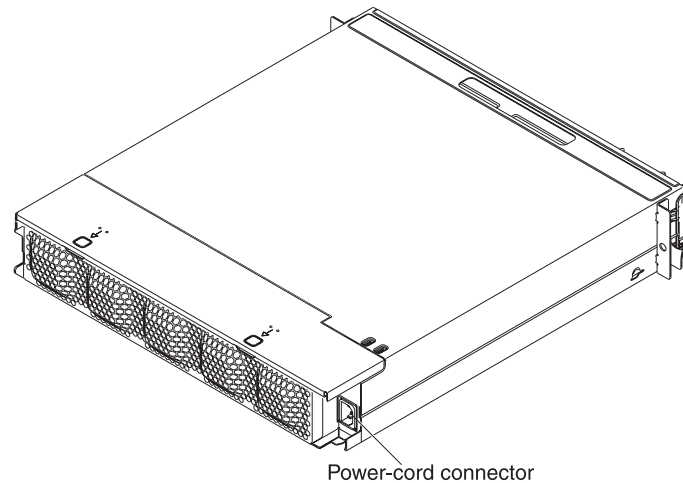

Power-cord connector: Connect the power cord to this connector. When the chassis is installed in an iDataPlex rack, it is automatically connected to power through a power cord that is mounted to the rack rail.

Turning on the system-board tray

After you install the system-board tray in a chassis, the system-board tray can start in any of the following ways.

Important: To avoid potential problems during startup, disconnect any USB flash drives from the system that contain the Smart Launch Utility before you turn on the system-board tray.

- You can press the power-control button on the front of the system-board tray (see “Operator panel controls, connectors, LEDs, and power” on page 19) to start the system-board tray.
- In an IPMI environment, the system administrator can turn on the system-board tray by using the IPMI **chassis control** command.
- If a power failure occurs, the system-board tray can start automatically when power is restored, if it is configured to do so.

Turning off the system-board tray

When you turn off the system-board tray, it is still connected to ac power through the chassis power supply. The system-board tray still can respond to requests from the IMM, such as a remote request to turn on the system-board tray. To remove all power from the system-board tray, you must remove the tray from the chassis.

Shut down the operating system before you turn off the system-board tray. See the operating-system documentation for information about shutting down the operating system.

The system-board tray can be turned off in any of the following ways:

- You can press the power-control button on the front of the system-board tray (see “Operator panel controls, connectors, LEDs, and power” on page 19). This starts an orderly shutdown of the operating system, if this feature is supported by the operating system.
- You can turn off the system-board tray from the operating system, if the operating system supports this feature. After an orderly shutdown of the operating system, the system-board tray will be turned off automatically.
- In an IPMI environment, the system administrator can turn off the system-board tray by using the IPMI **chassis control** command.
- If the operating system stops functioning, you can press and hold the power-control button for more than 4 seconds to turn off the system-board tray.
- You might be able to turn off the system-board tray by using an optional management appliance.
 - If the system is not operating correctly, the management appliance might automatically turn off the system-board tray.
 - Through the management appliance control interface, you might also be able to configure the management appliance to turn off the system-board tray. For additional information, see the documentation for your management appliance.

Chapter 3. Installing optional devices

This section provides detailed instructions for installing optional hardware devices.

Installation guidelines

Before you install optional devices, read the following information:

- Read the safety information that begins on page vii and “Handling static-sensitive devices” on page 24. This information will help you work safely.
- Before you install optional hardware devices, make sure that the server is working correctly. Start the server, and make sure that the operating system starts, if an operating system is installed, or that an error message is displayed, indicating that an operating system was not found but the server is otherwise working correctly. If the server is not working correctly, see the *Problem Determination and Service Guide* for diagnostic information.
- Observe good housekeeping in the area where you are working. Place removed covers and other parts in a safe place.
- Do not attempt to lift an object that you think is too heavy for you. If you have to lift a heavy object, observe the following precautions:
 - Make sure that you can stand safely without slipping.
 - Distribute the weight of the object equally between your feet.
 - Use a slow lifting force. Never move suddenly or twist when you lift a heavy object.
 - To avoid straining the muscles in your back, lift by standing or by pushing up with your leg muscles.
- Back up all important data before you make changes to disk drives.
- Have a small flat-blade screwdriver and a small Phillips screwdriver available.
- You do not have to turn off the system-board tray to install or replace hot-swap drives or hot-plug Universal Serial Bus (USB) devices. However, you must shut down the operating system and turn off the system-board tray before you remove the system-board tray from a chassis or before you install simple-swap hard disk drives.
- Blue on a component indicates touch points, where you can grip the component to remove or install it, open or close a latch, and so on.
- Orange on a component or an orange label on or near a component indicates that the component can be hot-swapped, which means that if the server and operating system support hot-swap capability, you can remove or install the component while the server is running. (Orange can also indicate touch points on hot-swap components.) See the instructions for removing or installing a specific hot-swap component for any additional procedures that you might have to perform before you remove or install the component.

System reliability guidelines

To help ensure proper cooling and system reliability, make sure that the following requirements are met:

- Each of the drive bays has a drive or a filler panel and electromagnetic compatibility (EMC) shield installed in it.
- You have followed the cabling instructions that come with optional adapters.
- You have replaced a hot-swap drive within 2 minutes of removal.

- The system-board tray battery is operational. If the battery becomes defective, replace it immediately.
- Microprocessor socket 2 always contains either a microprocessor baffle or a microprocessor and heat sink.
- You have replaced one or both system-board trays within 2 minutes of removal.
- For a 2U compute server, do not operate the upper system-board tray with the lower system-board tray removed or powered off, except for servicing.

Handling static-sensitive devices

Attention: Static electricity can damage the server and other electronic devices. To avoid damage, keep static-sensitive devices in their static-protective packages until you are ready to install them.

To reduce the possibility of damage from electrostatic discharge, observe the following precautions:

- Limit your movement. Movement can cause static electricity to build up around you.
- The use of a grounding system is recommended. For example, wear an electrostatic-discharge wrist strap, if one is available.
- Handle the device carefully, holding it by its edges or its frame.
- Do not touch solder joints, pins, or exposed circuitry.
- Do not leave the device where others can handle and damage it.
- While the device is still in its static-protective package, touch it to an *unpainted* metal surface on the outside of the rack, chassis, or system-board tray for at least 2 seconds. This drains static electricity from the package and from your body.
- Remove the device from its package and install it directly into the system-board tray or enclosure without setting down the device. If it is necessary to set down the device, put it back into its static-protective package. Do not place the device on the system-board tray cover or on a metal surface.
- Take additional care when you handle devices during cold weather. Heating reduces indoor humidity and increases static electricity.

Removing a 3U chassis from an iDataPlex rack

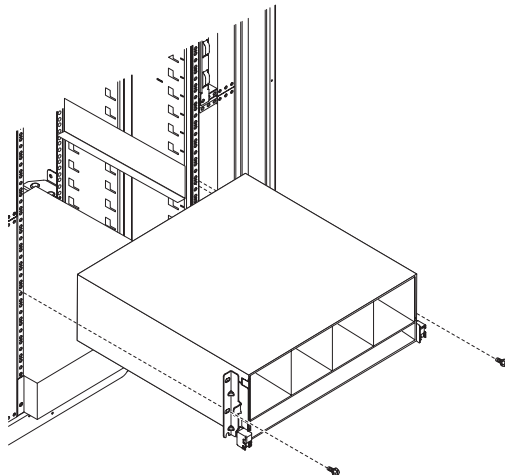

To remove a 3U chassis from an iDataPlex rack, complete the following steps:

1. Read the safety information that begins on page vii and “Installation guidelines” on page 23.
2. Turn off the server and all attached devices (see “Turning off the system-board tray” on page 21).
3. If external cables are connected to the front of the system-board tray, note where they are connected; then, remove them.
Attention: When you use RAID arrays, hard disk drives must be installed in the same location from which they were removed.
4. Note where the hard disk drives are installed; then, remove them (see “Removing a hard disk drive” on page 30).

Statement 4:

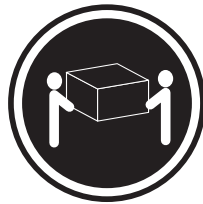

≥ 18 kg (39.7 lb)



≥ 32 kg (70.5 lb)

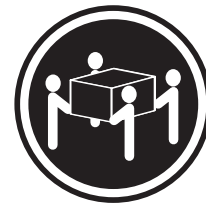

≥ 55 kg (121.2 lb)

CAUTION:

Use safe practices when lifting.

5. Remove the 2 screws and slide the 3U chassis from the iDataPlex rack.
6. Set the 3U chassis on a flat, static-protective surface.

Removing a system-board tray from a 2U chassis

Notes:

1. If two system-board trays are installed in the chassis, they can be removed independently of each other.
2. If an expansion enclosure is installed on the system-board tray, you will remove the expansion enclosure and the system-board tray from the chassis as one assembly.

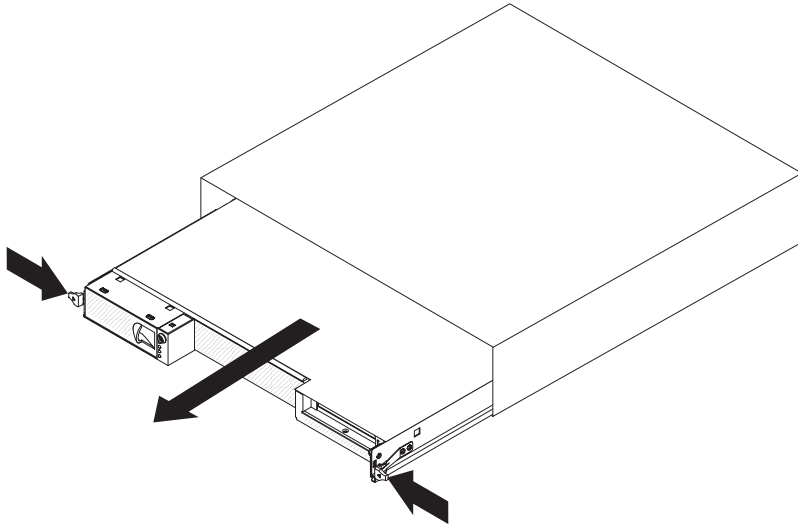

To remove a system-board tray from a 2U chassis, complete the following steps:

1. Read the safety information that begins on page vii and “Installation guidelines” on page 23.
2. Turn off the system-board tray and all attached devices (see “Turning off the system-board tray” on page 21).
3. If external cables are connected to the front of the system-board tray or expansion enclosure, note where they are connected; then, remove them.
4. Press in on the two release handles, pull the system-board tray and expansion enclosure, if one is attached, out of the 2U chassis, and set it on a flat, static-protective surface.

Removing a system-board tray from a 3U chassis

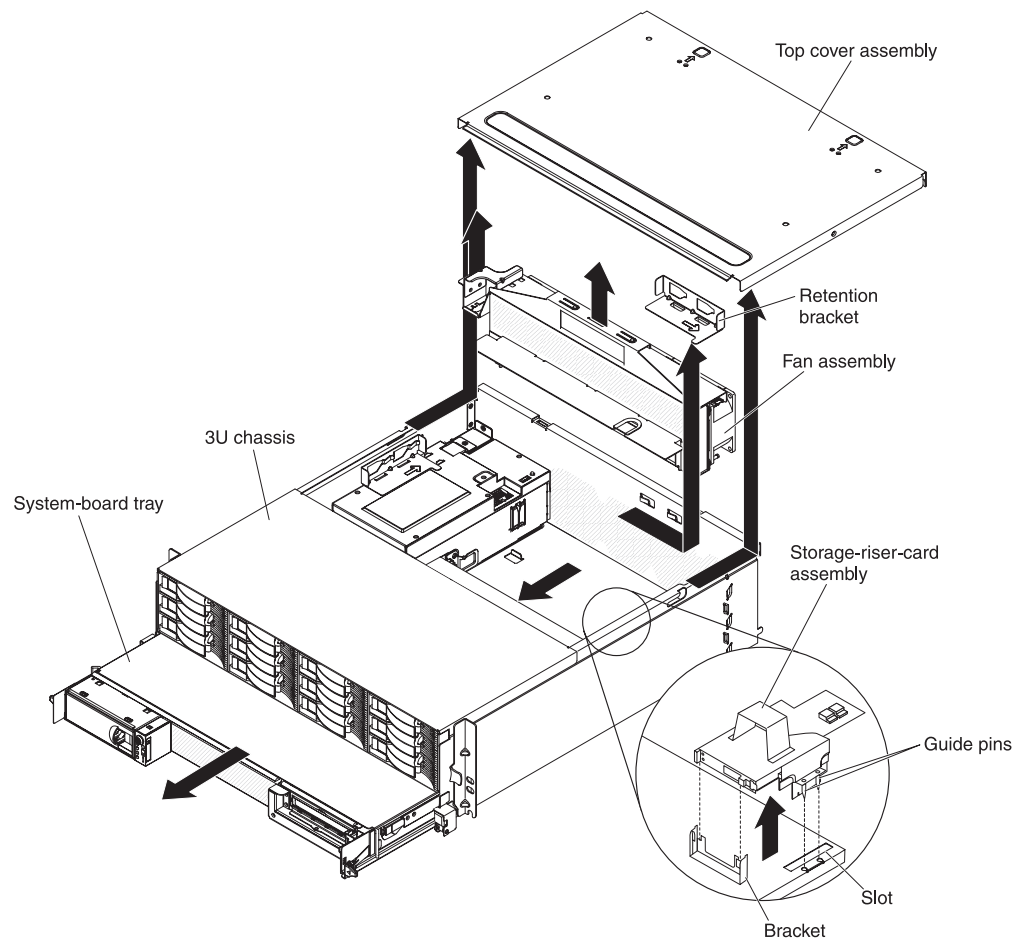

To remove a system-board tray from a 3U chassis, complete the following steps:

1. Read the safety information that begins on page vii and “Installation guidelines” on page 23.
2. Turn off the server and all attached devices (see “Turning off the system-board tray” on page 21).
3. If external cables are connected to the front of the system-board tray, note where they are connected; then, remove them.
4. Remove the 3U chassis from the iDataPlex rack (see “Removing a 3U chassis from an iDataPlex rack” on page 24).
5. Press on the two release latches at the top-rear edge of the top-cover assembly; then, slide the top-cover assembly toward the rear of the 3U chassis and remove it.
6. Note the signal cable routing and connection locations; then, disconnect the signal cables from the assembly.
Attention: When you move the storage-riser-card assembly, do not allow it to touch any components or structures inside the 3U chassis.
7. Lift up on the storage-riser-card assembly.

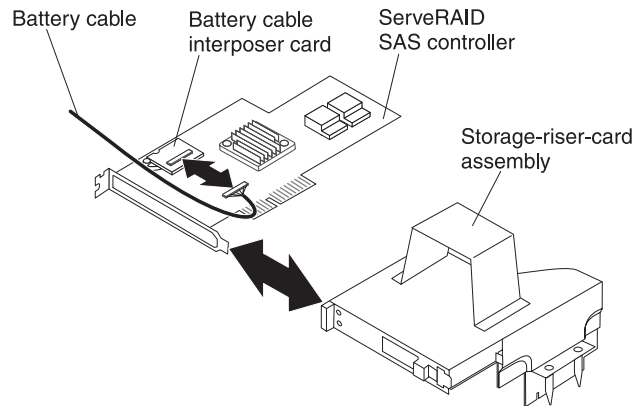

8. Turn the storage-riser-card assembly to access the ServeRAID SAS controller.
9. Pull the controller from the connector on the storage-riser-card assembly.
10. Disconnect the battery cable from the battery cable interposer card.
11. Remove the storage-riser-card assembly and ServeRAID SAS controller from the 3U chassis.
12. Slide and release the retention bracket that secures the fan assembly, and remove the bracket from the chassis.
13. Lift up on both fan-assembly handles and remove the fans from the 3U chassis.
14. Note the cable routing and connection locations; then, disconnect the cables that connect the system-board tray to the 3U chassis.
15. Push on the back edge of the system-board tray from inside the 3U chassis and slide the system-board tray forward.
16. Pull the system-board tray out of the 3U chassis and set it on a flat, static-protective surface.

Removing the system-board tray cover

Note: If an expansion enclosure is installed on the system-board tray, remove it instead (see “Removing an expansion enclosure” on page 29).

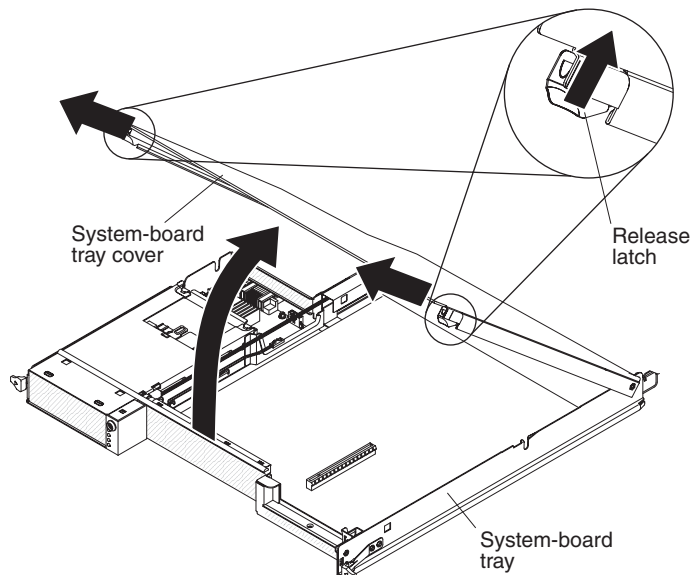

To remove the system-board tray cover, complete the following steps:

1. Read the safety information that begins on page vii and “Installation guidelines” on page 23.
2. Turn off the system-board tray and all attached devices (see “Turning off the system-board tray” on page 21).
3. If the system-board tray is installed in a chassis, remove it (see “Removing a system-board tray from a 2U chassis” on page 25 or “Removing a system-board tray from a 3U chassis” on page 27).
4. Carefully set the system-board tray on a flat, static-protective surface, with the cover side up.
5. Pull the cover release on each side of the system-board tray outward; then, lift the cover open.
6. Lift the cover off the system-board tray and store it for future use.

Note: If two system-board trays are installed in a 2U chassis, covers must be installed on both of them.

Removing an expansion enclosure

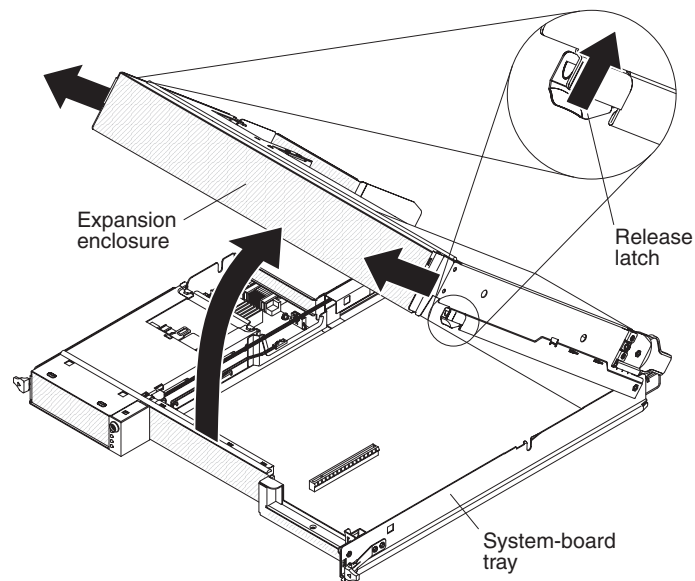

To remove an expansion enclosure, complete the following steps:

1. Read the safety information that begins on page vii and “Installation guidelines” on page 23.
2. Turn off the system-board tray and all attached devices (see “Turning off the system-board tray” on page 21).
3. If the system-board tray is installed in a chassis, remove it (see “Removing a system-board tray from a 2U chassis” on page 25).
4. Carefully set the system-board tray on a flat, static-protective surface.
5. If you are removing the enclosure, note the cable routing and connection locations; then, disconnect the cables that connect the expansion enclosure to the system-board tray.
6. Pull the expansion-unit release on each side of the system-board tray outward; then, rotate the expansion enclosure open.

- Using care not to pull on the cables, lift the expansion enclosure from the system-board tray and carefully set it upside down behind the system-board tray on a flat, static-protective surface.

Removing a hard disk drive

The dx360 M2 server configurations support installation of four hard disk drive types. The following sections describe the removal of each type of hard disk drive.

Removing a 3.5-inch hot-swap hard disk drive

Note: The following illustration shows how to remove a 3.5-inch hot-swap hard disk drive from a 3U chassis.

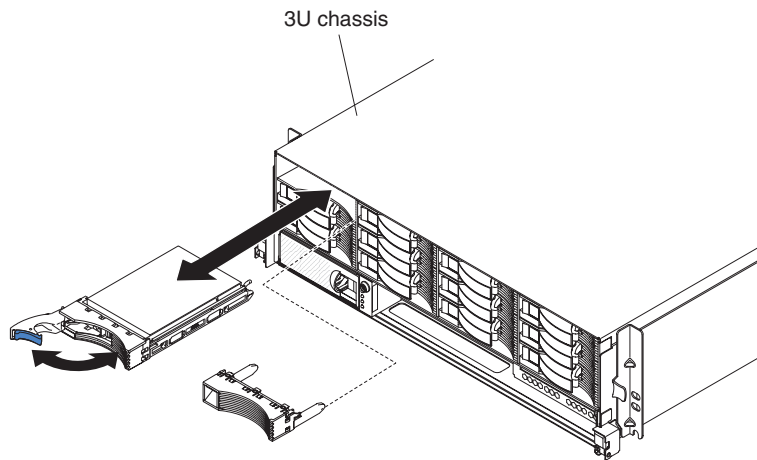

Note: You do not have to turn off the server to remove a hot-swap drive.

To remove a hot-swap hard disk drive, complete the following steps:

- Read the safety information that begins on page vii and “Installation guidelines” on page 23.
- Rotate the drive tray handle to the open position.
- Grasp the handle; then, pull the drive out of the drive bay.

Note: A hard disk drive or filler panel must always be installed in each drive bay when the server is turned on.

- Store the drive for later use.

Note: If you install or remove a hard disk drive, see the documentation that comes with your RAID adapter for information about reconfiguring the disk arrays.

Removing a 3.5-inch simple-swap hard disk drive

Note: The following illustration shows how to remove a 3.5-inch simple-swap hard disk drive from a 2U chassis.

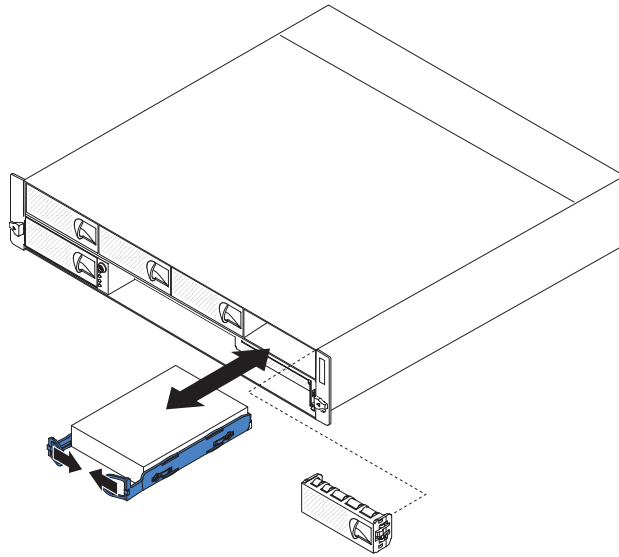

To remove a simple-swap hard disk drive, complete the following steps:

1. Read the safety information that begins on page vii and “Installation guidelines” on page 23.
2. Turn off the system-board tray and all attached devices (see “Turning off the system-board tray” on page 21).
3. Remove the filler panel from the bay that contains the simple-swap hard disk drive.
4. Pull the loops of the drive toward each other; then, pull the drive out of the drive bay.

Note: A hard disk drive or filler panel must always be installed in each drive bay when the server is turned on. In each drive bay that contains a simple-swap hard disk drive, a filler panel must always be installed in addition to the drive.

5. Store the drive and filler panel for later use.

Removing a 2.5-inch hot-swap hard disk drive

Note: The following illustration shows how to remove a 2.5-inch hot-swap hard disk drive from a 2U chassis.

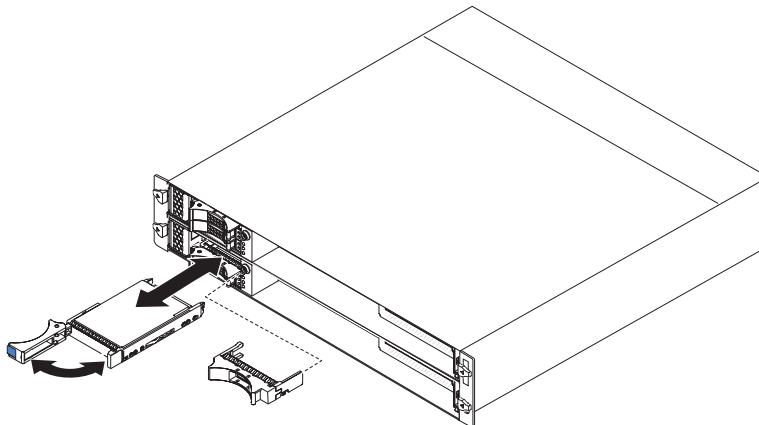

Note: You do not have to turn off the server to remove a hot-swap drive.

To remove a 2.5-inch hot-swap hard disk drive, complete the following steps:

1. Read the safety information that begins on page vii and “Installation guidelines” on page 23.
2. Rotate the drive tray handle to the open position.
3. Grasp the handle; then, pull the drive out of the drive bay.

Note: A hard disk drive or filler panel must always be installed in each drive bay when the server is turned on.

4. Store the drive for later use.

Note: If you install or remove a hard disk drive, see the documentation that comes with your RAID adapter for information about reconfiguring the disk arrays.

Removing a 2.5-inch simple-swap hard disk drive or solid-state drive

Note: The following illustration shows how to remove a 2.5-inch simple-swap hard disk drive or solid-state drive from a 2U chassis.

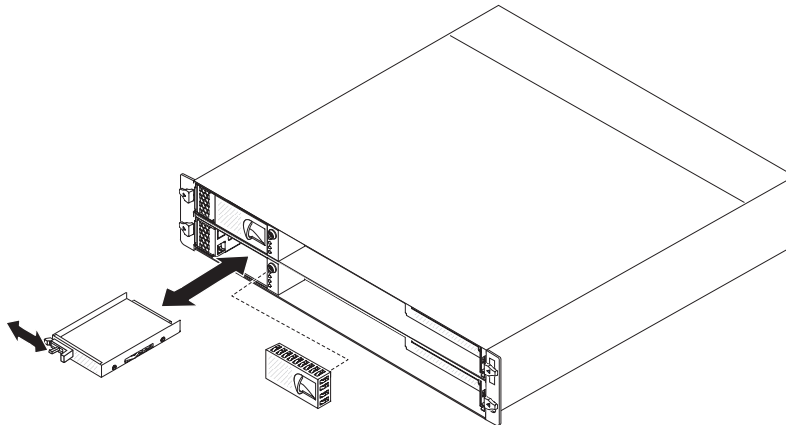

To remove a 2.5-inch simple-swap hard disk drive or solid-state drive, complete the following steps:

1. Read the safety information that begins on page vii and “Installation guidelines” on page 23.
2. Turn off the system-board tray and all attached devices (see “Turning off the system-board tray” on page 21).
3. Remove the filler panel from the bay that contains the simple-swap hard disk drive.
4. Slide the retention tab; then, pull the drive out of the drive bay.

Note: A drive or filler panel must always be installed in each drive bay when the server is turned on. In each drive bay that contains a simple-swap hard disk drive or solid-state drive, a filler panel must always be installed in addition to the drive.

5. Store the drive for later use.

Installing an adapter

The following notes describe the types of adapters that the server supports and other information that you must consider when you install an adapter:

- To ensure that a ServeRAID-MR10i adapter or ServeRAID-BR10i adapter works correctly in your UEFI-based server, make sure that the adapter firmware is at the latest level.

Important: Some cluster solutions require specific code levels or coordinated code updates. If the device is part of a cluster solution, verify that the latest level of code is supported for the cluster solution before you update the code.

- Locate the documentation that comes with the adapter and follow those instructions in addition to the instructions in this section. If you have to change switch settings or jumper settings on the adapter, follow the instructions that come with the adapter.
- Read the documentation that comes with your operating system.
- The server supports the following riser cards for optional adapters:
 - One-slot riser card: PCIe x16 (x16) adapters
 - Two-slot riser card: PCIe x16 (x8) adapters

Important: The (x8) designation identifies an x16 connector that supports x8 adapters and x16 adapters that can downshift to operate at the x8 bandwidth. For example, if you install an x16 adapter that can downshift to the x8 bandwidth in the connector, the adapter will run at the x8 bandwidth. See the documentation that comes with the adapter for compatibility information.

- In configurations that have a two-slot riser card, the server scans the PCIe adapters to assign system resources, following the boot sequence that is set in the Setup utility.

Important: The maximum power consumption from all supply voltages for a single PCIe slot is the same as specified in PCI Local Bus Specification Revision 2.3 for conventional slots (25 W).

Installing an adapter in a one-slot riser card

Note: The one-slot riser card supports installation of only half-length, full-height adapters.

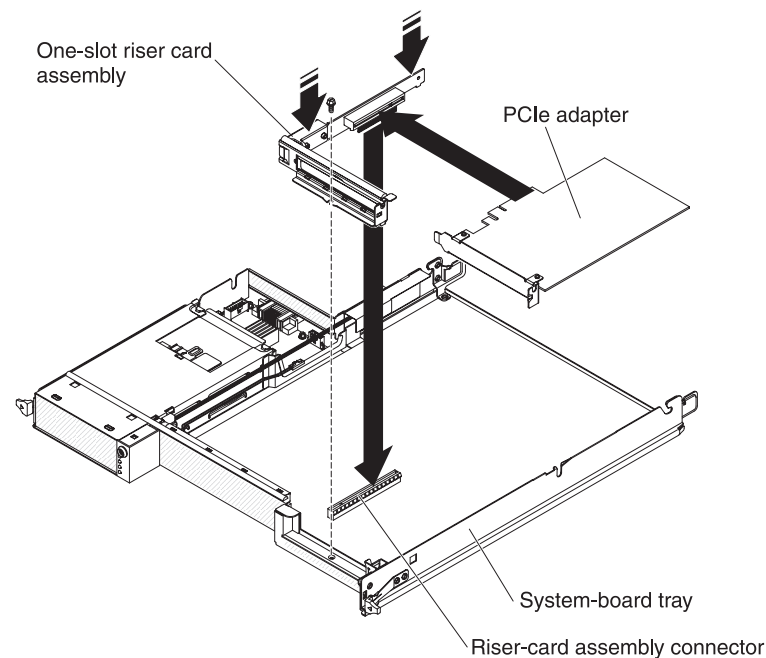

To install an adapter in a one-slot riser card, complete the following steps:

1. Read the safety information that begins on page vii and “Installation guidelines” on page 23.
2. Turn off the system-board tray and all attached devices (see “Turning off the system-board tray” on page 21).
3. If the system-board tray is installed in a chassis, remove it (see “Removing a system-board tray from a 2U chassis” on page 25 or “Removing a system-board tray from a 3U chassis” on page 27).
4. If an expansion enclosure is installed on the system-board tray, remove it (see “Removing an expansion enclosure” on page 29); otherwise, remove the system-board tray cover (see “Removing the system-board tray cover” on page 28).
5. Remove the riser-card retaining screw on the front of the chassis. Store the screw for future use.

Note: If an adapter is already installed in the riser card, the riser card and adapter are removed together.

6. Carefully grasp the one-slot riser card by its top edge or upper corners, and pull the riser card straight up and out of the system board.
7. Carefully set the riser card on a flat, static-protective surface. If an adapter is installed in the riser card, remove it.
8. Touch the static-protective package that contains the adapter that you are installing to any *unpainted* metal surface on the chassis or rack; then, remove the adapter from the static-protective package. Avoid touching the components and gold-edge connectors on the adapter.
9. Follow the instructions that come with the adapter to set any jumpers or switches.
10. Carefully grasp the adapter by the top edge or upper corner and insert it in the one-slot riser card. Align the adapter with the connector on the riser card; then, press the adapter firmly into the connector.

Note: Make sure that the adapter is inserted correctly. Improper installation of an adapter might damage the PCIe riser-card assembly or the adapter.

11. Follow the cabling instructions, if any, that come with the adapter. If possible, route the adapter cables before you install the adapter.
12. Pinch the two sides of the one-slot riser card, and align the riser card with the riser-card connector on the system board; then, press the riser card firmly, evenly with both hands, into the connector.
13. Install the riser-card retaining screw at the front of the chassis.

If you have other devices to install or remove, do so now. Otherwise, go to “Completing the installation” on page 45.

Installing an adapter in a two-slot riser card

Note: The two-slot riser card is part of an optional expansion enclosure; the riser card and adapters are attached to the expansion enclosure. This procedure assumes that an expansion enclosure is already installed on the system-board tray.

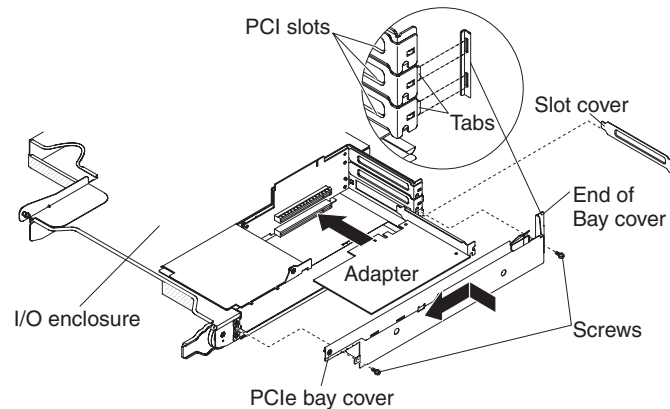

To install an adapter in a two-slot riser card, complete the following steps:

1. Read the safety information that begins on page vii and “Installation guidelines” on page 23.
2. Turn off the system-board tray and all attached devices (see “Turning off the system-board tray” on page 21).
3. If the system-board tray is installed in a chassis, remove it (see “Removing a system-board tray from a 2U chassis” on page 25).
4. Remove the expansion enclosure (see “Removing an expansion enclosure” on page 29) and set it upside down on a flat, static-protective surface.

Note: If an adapter is already installed in the riser card, the riser card and adapter are removed together.

5. Remove the screws, slide the PCIe adapter bay cover toward the front of the expansion enclosure, and remove it. Save the screws and the PCIe adapter bay cover for later use.
6. If an adapter is installed in the connector on the riser card where you are installing the new adapter, remove it.
7. Touch the static-protective package that contains the adapter that you are installing to any *unpainted* metal surface on the chassis or rack; then, remove the adapter from the static-protective package. Avoid touching the components and gold-edge connectors on the adapter.
8. If you are installing a full-length adapter, remove the blue adapter guide (if any) from the end of the adapter.

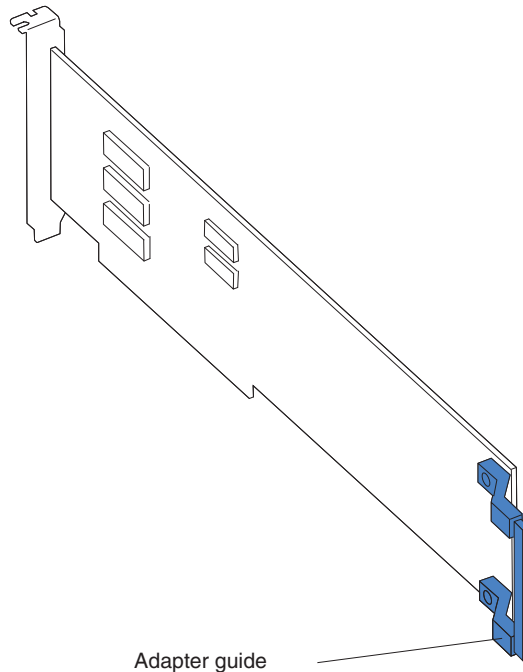

9. Follow the instructions that come with the adapter to set any jumpers or switches.
10. Carefully grasp the adapter by the top edge or upper corner, and insert it in the two-slot riser card. Align the adapter with the connector on the riser card; then, press the adapter firmly into the connector.
11. If you have another adapter to install, do so now. Otherwise, continue with step 12.
12. If any cables must be connected to an adapter, connect them. Route these cables through the hole at the side of the expansion enclosure.
13. Align the tabs on the PCIe adapter bay cover with the holes on the expansion enclosure; then, slide the PCIe adapter bay cover toward the rear of the expansion enclosure until it stops.
14. Install the PCIe adapter bay cover screws.

If you have other devices to install or remove, do so now. Otherwise, go to “Completing the installation” on page 45.

Installing a hard disk drive

The dx360 M2 server configurations support installation of four hard disk drive types. The following sections describe the installation of each type of hard disk drive.

Installing a 3.5-inch hot-swap hard disk drive

Note: The following illustration shows how to install a 3.5-inch hot-swap hard disk drive in a 3U chassis.

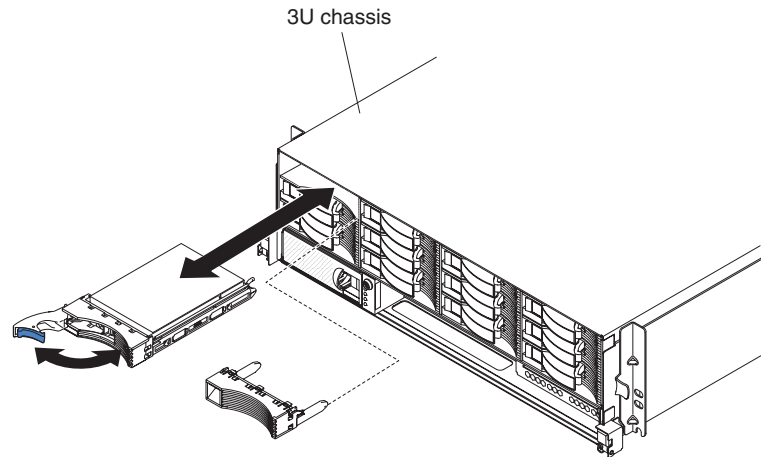

To install a hot-swappable hard disk drive, complete the following steps:

1. Read the safety information that begins on page vii and “Installation guidelines” on page 23.
2. Touch the static-protective package that contains the hard disk drive to any *unpainted* metal surface on the chassis or rack; then, remove the hard disk drive from the package.
Attention: Do not press on the top of the drive. Pressing the top might damage the drive.
3. Make sure that the drive tray handle is in the open position.
4. Align the drive with the guide rails in the drive bay; then, carefully slide the drive into the bay until the drive stops.
5. Rotate the drive tray handle to the closed position.

Note: If you install or remove a hard disk drive, see the documentation that comes with your RAID adapter for information about reconfiguring the disk arrays.

Installing a 3.5-inch simple-swap hard disk drive

Notes:

1. Depending on your server configuration, you can install either 3.5-inch SAS simple-swap hard disk drives or 3.5-inch SATA simple-swap hard disk drives. You cannot use SAS simple-swap hard disk drives and SATA simple-swap hard disk drives in the same server.
2. The following illustration shows how to install a 3.5-inch simple-swap hard disk drive in a 2U chassis.

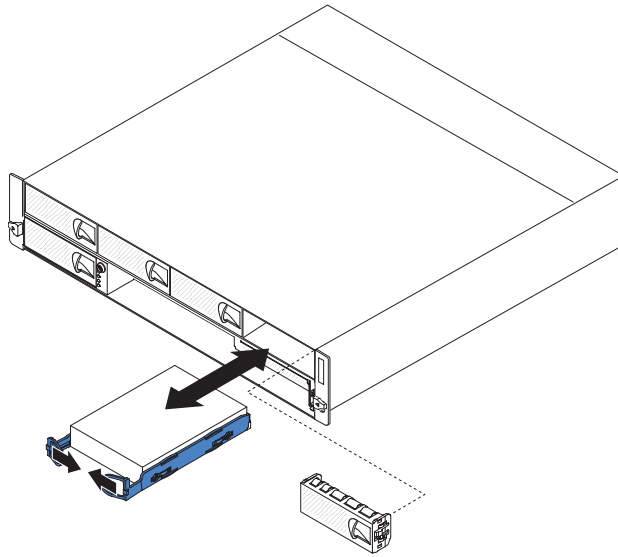

To install a simple-swap hard disk drive, complete the following steps:

1. Read the safety information that begins on page vii and “Installation guidelines” on page 23.
2. Turn off the server and all attached devices (see “Turning off the system-board tray” on page 21).
3. Remove the filler panel from the simple-swap hard disk drive bay.
4. Touch the static-protective package that contains the hard disk drive to any *unpainted* metal surface on the chassis or rack; then, remove the hard disk drive from the package.

Attention: Do not press on the top of the drive. Pressing the top might damage the drive.

5. Align the drive with the guide rails in the drive bay.
6. Pull the loops of the drive toward each other; then, carefully slide the drive into the bay until it stops, and release the loops.

Note: Do not release the loops on the drive until it is completely seated.

7. Install the filler panel in the simple-swap hard disk drive bay.

If you have other devices to install or remove, do so now. Otherwise, turn on the system-board tray (see “Turning on the system-board tray” on page 21).

Note: If the server has a PCIe RAID adapter and you install or remove a hard disk drive, see the documentation that comes with your RAID adapter for information about reconfiguring the disk arrays.

Installing a 2.5-inch hot-swap hard disk drive

Notes:

1. The 2.5-inch hot-swap hard disk drives can be installed only in system configurations that support this drive type.
2. The following illustration shows how to install a 2.5-inch hot-swap hard disk drive in a 2U chassis.

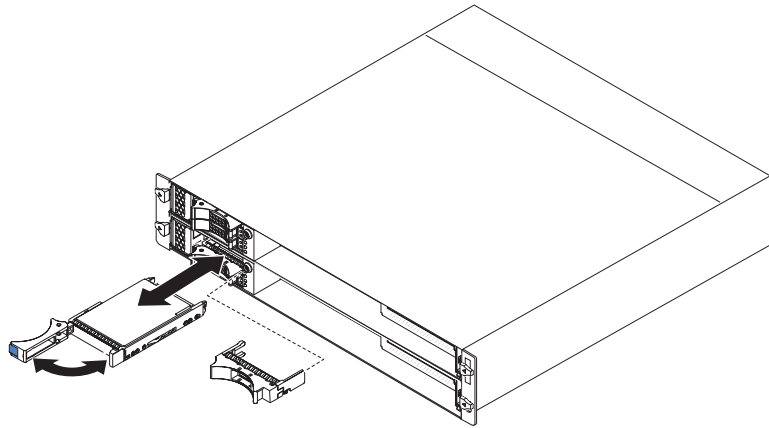

To install a 2.5-inch hot swap hard disk drive, complete the following steps:

1. Read the safety information that begins on page vii and “Installation guidelines” on page 23.
2. Touch the static-protective package that contains the hard disk drive to any *unpainted* metal surface on the chassis or rack; then, remove the hard disk drive from the package.
Attention: Do not press on the top of the drive. Pressing the top might damage the drive.
3. Make sure that the drive tray handle is in the open position.
4. Align the drive with the guide rails in the drive bay; then, carefully slide the drive into the bay until the drive stops.
5. Rotate the drive tray handle to the closed position.

Note: If you install or remove a hard disk drive, see the documentation that comes with your RAID adapter for information about reconfiguring the disk arrays.

Installing a 2.5-inch simple-swap hard disk drive or solid-state drive

Notes:

1. The 2.5-inch simple-swap hard disk drives or solid-state drives can be installed only in system configurations that support this drive type.
2. The following illustration shows how to install a 2.5-inch simple-swap hard disk drive or solid-state drive in a 2U chassis.

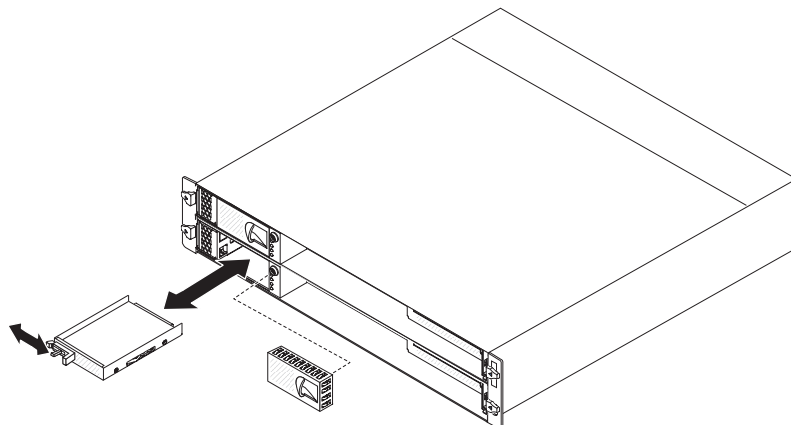

To install a 2.5-inch simple-swap hard disk drive or solid-state drive, complete the following steps:

1. Read the safety information that begins on page vii and “Installation guidelines” on page 23.
2. Turn off the server and all attached devices (see “Turning off the system-board tray” on page 21).
3. Remove the filler panel from the simple-swap hard disk drive bay.
4. Touch the static-protective package that contains the hard disk drive or solid-state drive to any *unpainted* metal surface on the chassis or rack; then, remove the drive from the package.

Attention: Do not press on the top of the drive. Pressing the top might damage the drive.

5. Align the drive with the guide rails in the drive bay.
6. Slide the retention tab; then, carefully slide the drive into the bay until it stops, and release the retention tab.
7. Install the filler panel in the simple-swap hard disk drive bay.

If you have other devices to install or remove, do so now. Otherwise, turn on the system-board tray (see “Turning on the system-board tray” on page 21).

Note: If the server has a PCIe RAID adapter and you install or remove a hard disk drive, see the documentation that comes with your RAID adapter for information about reconfiguring the disk arrays.

Installing a memory module

The following notes describe the types of dual inline memory modules (DIMMs) that the system-board tray supports and other information that you must consider when you install DIMMs:

- The system-board tray supports only industry-standard double-data-rate 3 (DDR3), -800, -1066, or -1333 MHz, PC3-10600R-999, registered, synchronous dynamic random-access memory (SDRAM) dual inline memory modules (DIMMs) with error correcting code (ECC).
- The system-board tray supports up to 16 DIMMs.
- The system-board tray supports three single-rank or dual-rank DIMMs per channel. Table 1 shows an example of the maximum amount of memory that you can install.

Table 1. Maximum memory installation

DIMM type	Maximum number of DIMMs	DIMM size	Total memory
Single-rank	16	1 GB	16 GB
Dual-rank	16	2 GB	32 GB
Dual-rank	16	4 GB	64 GB

- Table 2 lists the DIMM connectors on each memory channel.

Table 2. Connectors on each memory channel

Memory channel	Microprocessor 1 DIMM connectors	Microprocessor 2 DIMM connectors
Channel 0	1, 2, and 3	9, 10, and 11

Table 2. Connectors on each memory channel (continued)

Memory channel	Microprocessor 1 DIMM connectors	Microprocessor 2 DIMM connectors
Channel 1	4, 5, and 6	12, 13, and 14
Channel 2	7 and 8	15 and 16

- The DIMM options that are available are 1 GB, 2 GB, and 4 GB. The system-board tray supports a minimum of 1 GB and a maximum of 64 GB of system memory.

Note: The amount of usable memory will be reduced depending on the system configuration. A certain amount of memory must be reserved for system resources. To view the total amount of installed memory and the amount of configured memory, run the Setup utility. For additional information, see “Using the Setup utility” on page 54.

- A minimum of two DIMMs must be installed for each microprocessor. However, to improve system performance, install a minimum of three DIMMs for each installed microprocessor.
- The maximum operating speed of the system-board tray is determined by the slowest DIMM, the number of DIMMs on each channel, and the combination of DIMM rank and speed.
- The system-board tray comes with a minimum of two 1 GB DIMMs, installed in slots 3 and 6. When you install additional DIMMs, install the DIMMs in the order shown in Table 3 to optimize system performance. All three channels on the memory interface for each microprocessor can be populated in any order and have no matching requirements.

Table 3. Non-mirroring (normal) mode DIMM installation sequence

Microprocessors installed	DIMM connector
1	3, 6, 8, 2, 5, 7, 1, then 4
2	3, 11, 6, 14, 8, 16, 2, 10, 5, 13, 7, 15, 1, 9, 4, then 12

- The following illustration shows the DIMM connectors on the system board.

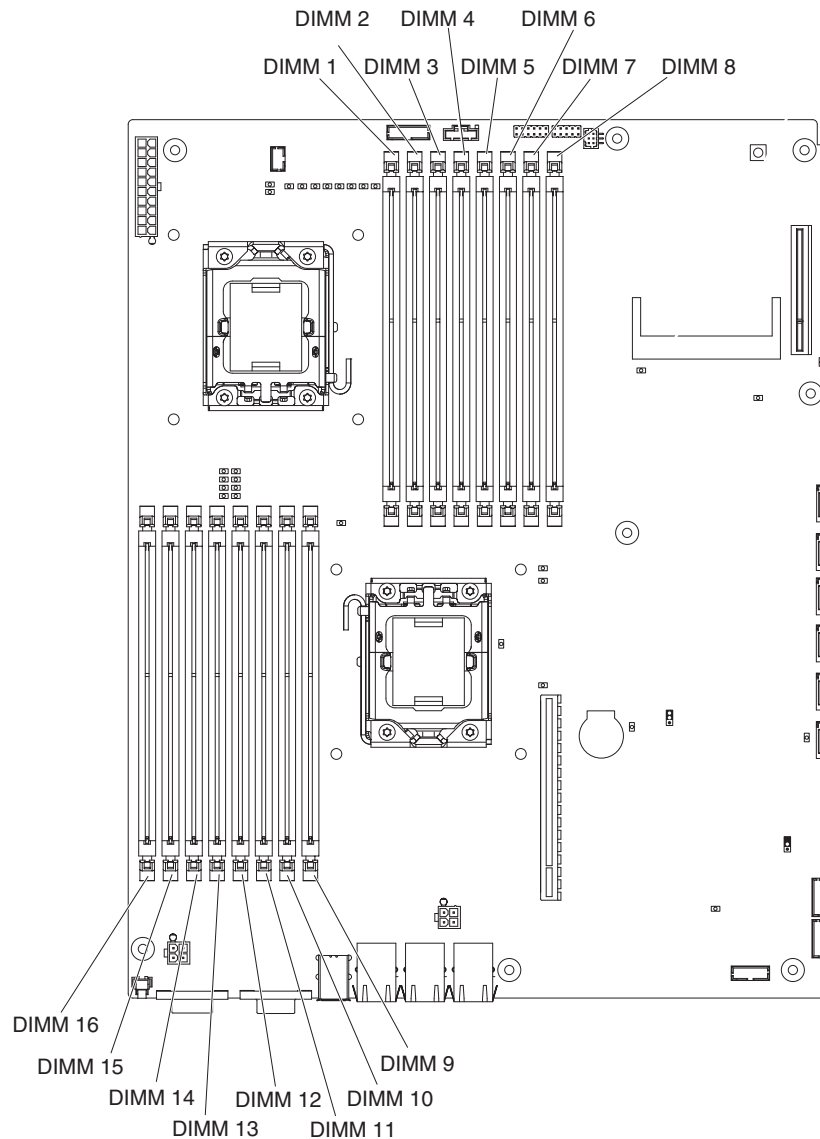

- Memory-mirroring mode replicates and stores data on two pairs of DIMMs within two channels simultaneously. If a failure occurs, the memory controller switches from the primary pair of DIMMs to the backup pair of DIMMs. You must enable memory mirroring through the Setup utility. See “Using the Setup utility” on page 54. When you use the memory-mirroring mode, you must consider the following information:
 - Table 4 and Table 5 on page 43 show the installation sequence for installing DIMMs in memory-mirroring mode.

Table 4. Microprocessor 1 memory-mirroring DIMM installation sequence

Microprocessor number	Pair	DIMM connectors
1	1	3, 6
1	2	2, 5
1	3	1, 4

Table 5. Microprocessor 2 memory-mirroring DIMM installation sequence

Microprocessor number	Pair	DIMM connectors
2	1	11, 14
2	2	10, 13
2	3	9, 12

- To support memory mirroring, the DIMMs in each pair must match but the pairs can be different from each other. For example, the first pair of DIMMs must match and the second pair of DIMMs must match; however, the first and second pair of DIMMs can be different from each other.
- Channel 2 DIMM connectors are not used in memory-mirroring mode.
- The maximum available memory is reduced by half when memory mirroring is enabled. For example, if you install 64 GB of memory, only 32 GB of addressable memory is available when you use memory mirroring.
- When you install or remove DIMMs, the system-board tray configuration information changes. When you restart the system-board tray, the system displays a message that indicates that the memory configuration has changed.

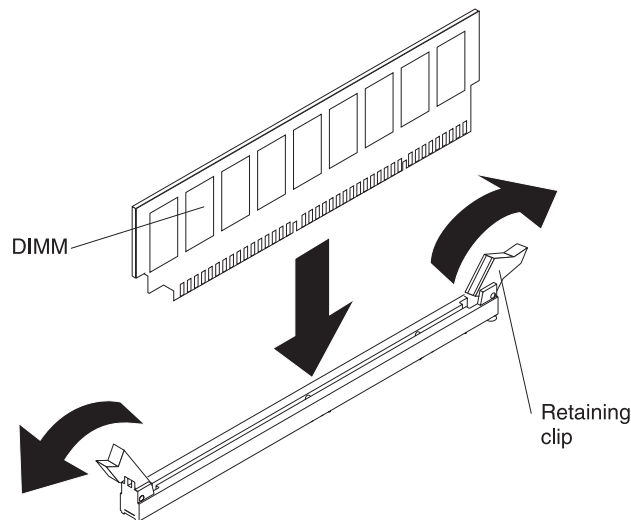

To install a DIMM, complete the following steps:

1. Read the safety information that begins on page vii and “Installation guidelines” on page 23.
2. Read the documentation that comes with the DIMM.
3. Turn off the system-board tray and all attached devices (see “Turning off the system-board tray” on page 21).
4. If the system-board tray is installed in a chassis, remove it (see “Removing a system-board tray from a 2U chassis” on page 25 or “Removing a system-board tray from a 3U chassis” on page 27).
5. If an expansion enclosure is installed on the system-board tray, remove it (see “Removing an expansion enclosure” on page 29); otherwise, remove the system-board tray cover (see “Removing the system-board tray cover” on page 28).
6. Locate the DIMM connectors (see “System-board connectors” on page 13). Determine the connectors into which you will install the DIMMs.

Attention: To avoid breaking the DIMM retaining clips or damaging the DIMM connectors, open and close the clips gently.

7. Open the retaining clips and, if necessary, remove any existing DIMM.
8. Touch the static-protective package that contains the DIMM to any *unpainted* metal surface on the system-board tray; then, remove the DIMM from the package.
9. Turn the DIMM so that the DIMM keys align correctly with the connector on the system board.
10. Insert the DIMM into the connector by aligning the edges of the DIMM with the slots at the ends of the DIMM connector. Firmly press the DIMM straight down into the connector by applying pressure on both ends of the DIMM simultaneously. The retaining clips snap into the locked position when the DIMM is firmly seated in the connector.

Attention: If there is a gap between the DIMM and the retaining clips, the DIMM has not been correctly installed. Open the retaining clips, remove the DIMM, and then reinsert it.

If you have other devices to install or remove, do so now. Otherwise, go to “Completing the installation” on page 45.

Installing an IBM virtual media key

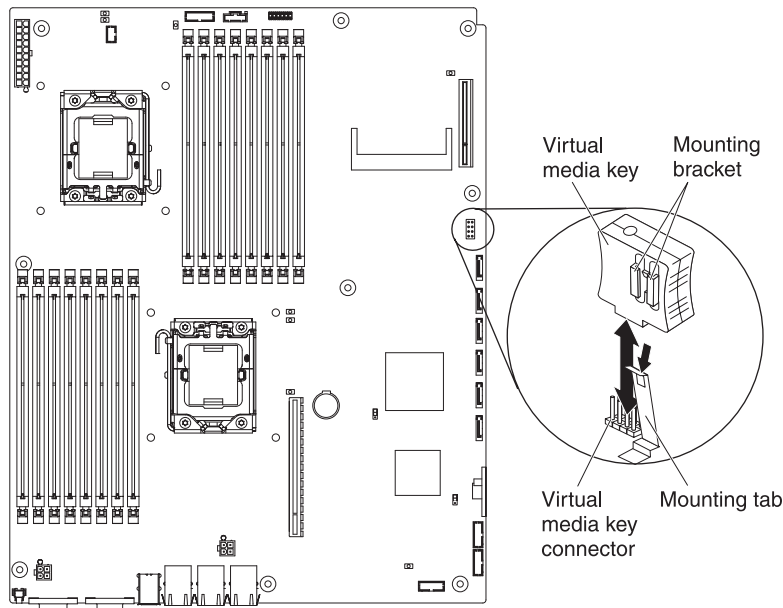

To install an IBM virtual media key, complete the following steps:

1. Read the safety information that begins on page vii and “Installation guidelines” on page 23.
2. Turn off the system-board tray and all attached devices (see “Turning off the system-board tray” on page 21).
3. If the system-board tray is installed in a chassis, remove it (see “Removing a system-board tray from a 2U chassis” on page 25 or “Removing a system-board tray from a 3U chassis” on page 27).

4. If an expansion enclosure is installed on the system-board tray, remove it (see “Removing an expansion enclosure” on page 29); otherwise, remove the system-board tray cover (see “Removing the system-board tray cover” on page 28).
5. Align the virtual media key with the connector.
6. Press on the virtual media key until it is firmly seated in the connector and make sure that the retention clip engages the virtual media key.

If you have other devices to install or remove, do so now. Otherwise, go to “Completing the installation”.

Completing the installation

To complete the installation, complete the following tasks. Instructions for each task are in one of the following sections.

1. Install the system-board tray cover (see “Reinstalling the system-board tray cover”) or expansion enclosure (see “Reinstalling an expansion enclosure” on page 46).
2. Install the system-board tray in the chassis (see “Reinstalling a system-board tray in a 2U chassis” on page 47 or “Reinstalling a system-board tray in a 3U chassis” on page 48).
3. Connect the cables. For more information, see “Connecting the cables” on page 51.
4. For some devices, run the server Setup utility. For more information, see “Updating the server configuration” on page 51.

Reinstalling the system-board tray cover

Attention: You cannot install the system-board tray into the chassis until the cover is installed and closed or an expansion enclosure is installed. Do not attempt to override this protection.

Note: If an expansion enclosure is installed on the system-board tray, the system-board tray cover is not used.

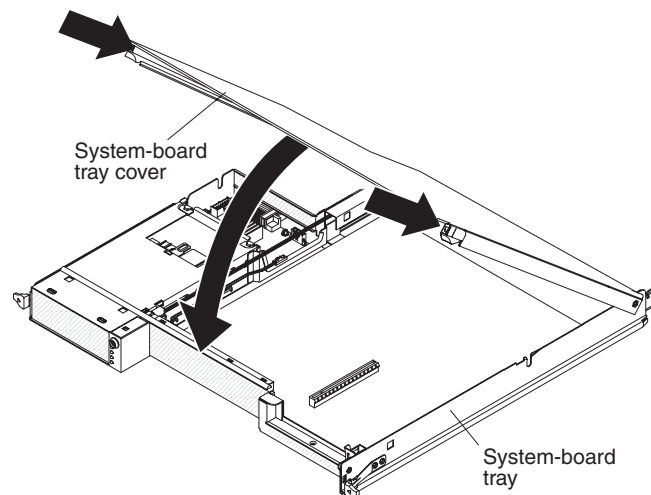

To reinstall the system-board tray cover, complete the following steps:

1. Lower the cover so that the pins at the rear slide down into the slots at the rear of the system-board tray. Before you close the cover, make sure that all

- components are installed and seated correctly, all internal cables are correctly routed, and you have not left loose tools or parts inside the system-board tray.
2. Pivot the cover to the closed position until it clicks into place.
 3. Install the system-board tray in the chassis (see “Reinstalling a system-board tray in a 2U chassis” on page 47 or “Reinstalling a system-board tray in a 3U chassis” on page 48).

Reinstalling an expansion enclosure

Attention: You cannot install the system-board tray into the chassis until the cover is installed and closed or an expansion enclosure is installed. Do not attempt to override this protection.

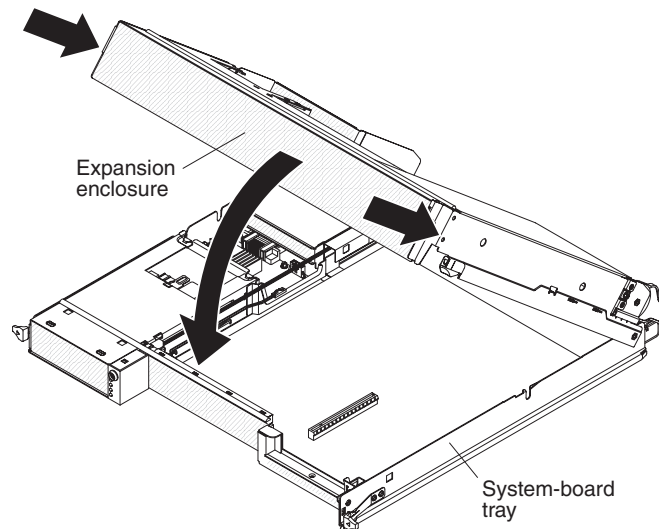

To reinstall an expansion enclosure, complete the following steps:

1. Orient the expansion enclosure above the system-board tray.
2. Lower the expansion enclosure so that the pins at the rear slide down into the slots at the rear of the system-board tray. Before you close the cover, make sure that all components are installed and seated correctly, all internal cables are correctly routed, and you have not left loose tools or parts inside the system-board tray.
3. If you disconnected cables when you removed the enclosure, reconnect them.
4. Pivot the expansion enclosure down onto the system-board tray until it clicks into place.
5. Install the system-board tray in the chassis (see “Reinstalling a system-board tray in a 2U chassis” on page 47).

Reinstalling a system-board tray in a 2U chassis

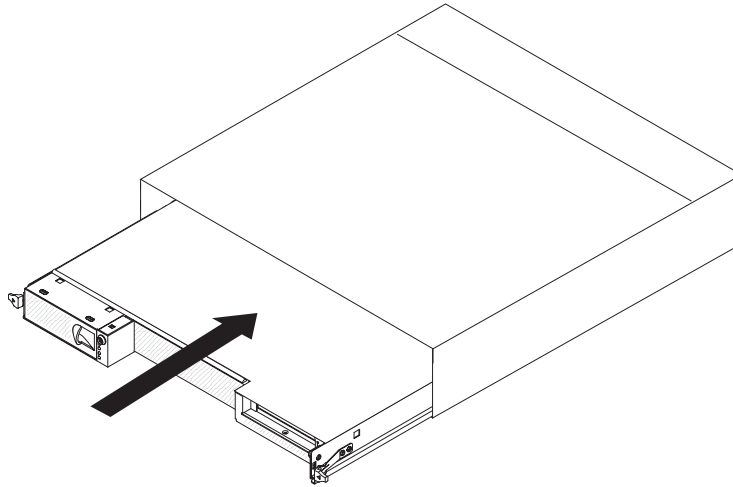

To reinstall a system-board tray in a 2U chassis, complete the following steps:

1. If an expansion enclosure is installed on the system-board tray, make sure that the blue air damper actuator is parallel to the system-board tray before you slide the assembly into the chassis.
2. Slide the system-board tray into the chassis until it stops and the release handles click into place.
3. Reconnect the cables on the front of the system-board tray.
4. Turn on the system-board tray (see “Turning on the system-board tray” on page 21).
5. Make sure that the power-on LED on the system-board tray operator panel is lit continuously, indicating that the system-board tray is receiving power and is turned on.

If you have changed the configuration of the system-board tray, you might have to update the server configuration through the Setup utility (see “Updating the server configuration” on page 51).

Reinstalling a system-board tray in a 3U chassis

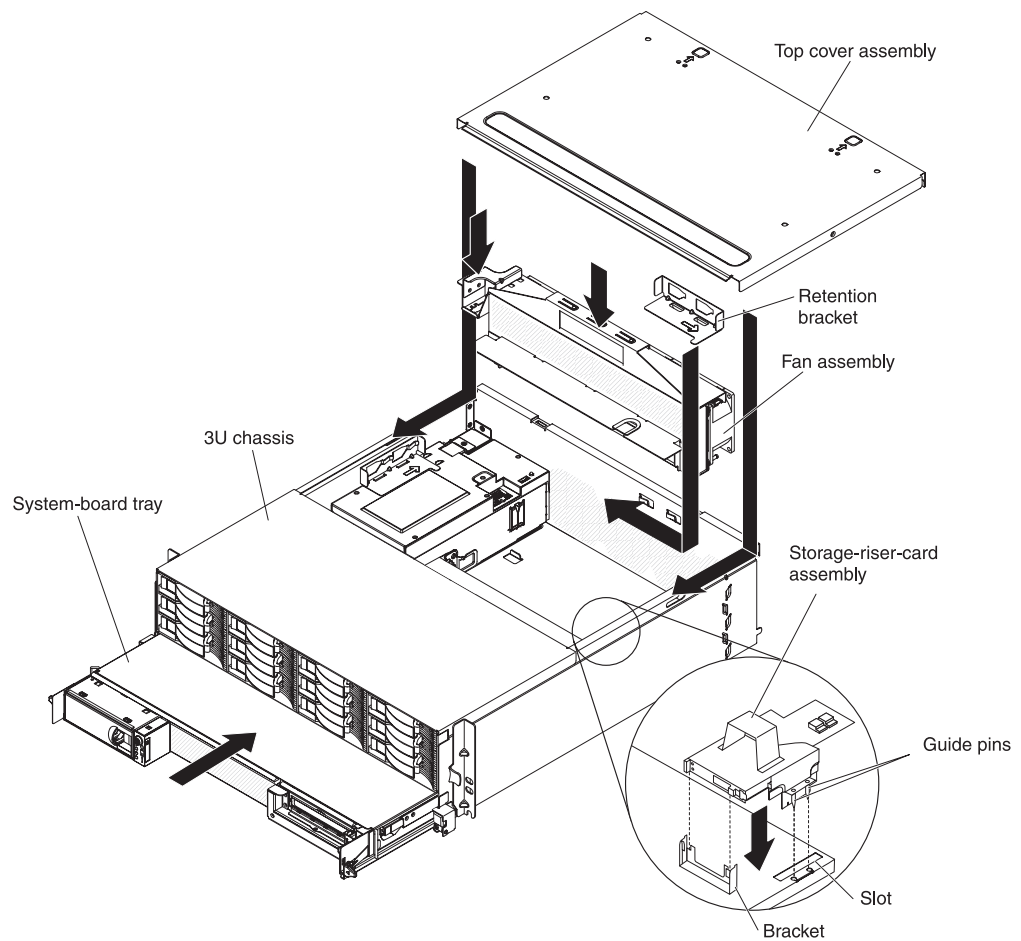

Note: You must remove the 3U chassis from the iDataPlex rack before you install the system-board tray (see “Removing a 3U chassis from an iDataPlex rack” on page 24).

To reinstall a system-board tray in a 3U chassis, complete the following steps:

1. Slide the system-board tray into the 3U chassis until it stops.
2. Reconnect the cables that connect the system-board tray and optional adapter to the 3U chassis.
3. Turn the fan assembly so that the connector aligns correctly with the connector in the power supply.
4. Insert the fan assembly into the 3U chassis. Firmly press the fan assembly straight down into the chassis by applying pressure on both fan-assembly handles simultaneously.
5. Reinstall the retention bracket that secures the fan assembly.

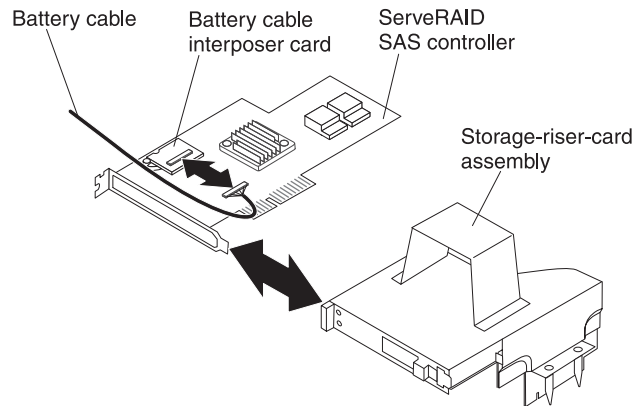

6. Connect the battery cable to the battery cable interposer card.
7. Align the ServeRAID SAS controller with the connector and the bracket on the storage-riser-card assembly and press the controller into place.

Attention: When you move the storage-riser-card assembly, do not allow it to touch any components or structures inside the 3U chassis.

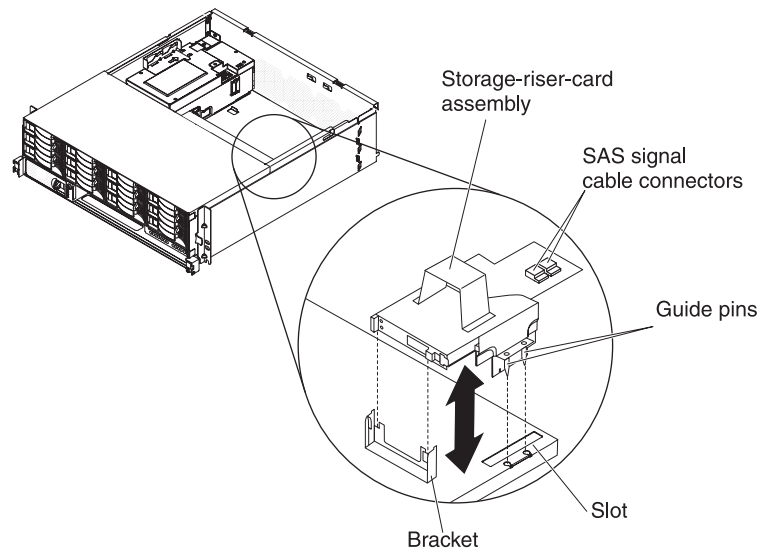

8. Align the storage-riser-card assembly with the guide pins and the slot in the system-board tray cover.
9. Press the assembly into place on the bracket.
10. Reconnect the signal cables to the ServeRAID SAS controller.
11. Align the top-cover assembly with the rear of the 3U chassis; then, slide it forward until it clicks into place.
12. Reinstall the 3U chassis in the iDataPlex rack (see “Reinstalling a 3U chassis in an iDataPlex rack” on page 50).
13. Install the hard disk drives (see “Installing a hard disk drive” on page 36).
14. Reconnect the cables on the front of the system-board tray.
15. Turn on the system-board tray (see “Turning on the system-board tray” on page 21).
16. Make sure that the power-on LED on the system-board tray operator panel is lit continuously, indicating that the system-board tray is receiving power and is turned on.

If you have changed the configuration of the system-board tray, you might have to update the server configuration through the Setup utility (see “Updating the server configuration” on page 51).

Reinstalling a 3U chassis in an iDataPlex rack

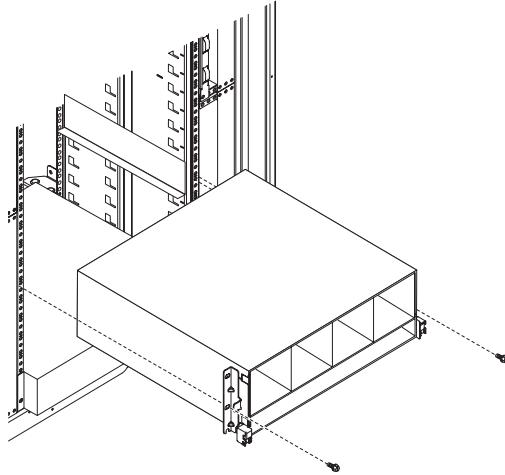

Statement 4:

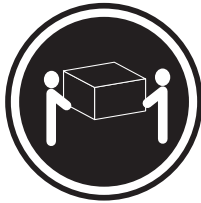

≥ 18 kg (39.7 lb)



≥ 32 kg (70.5 lb)

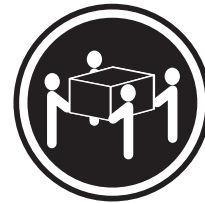

≥ 55 kg (121.2 lb)

CAUTION: Use safe practices when lifting.

To reinstall a 3U chassis in an iDataPlex rack, complete the following steps:

1. Align the 3U chassis with the rails on the iDataPlex rack; then, slide the 3U chassis into the rack until it is fully seated.
2. Install the M6 screws that secure the chassis to the rack.
3. Install the hard disk drives (see “Installing a hard disk drive” on page 36).
4. Reconnect the cables on the front of the system-board tray.
5. Turn on the system-board tray (see “Turning on the system-board tray” on page 21).
6. Make sure that the power-on LED on the system-board tray operator panel is lit continuously, indicating that the system-board tray is receiving power and is turned on.

If you have changed the configuration of the system-board tray, you might have to update the server configuration through the Setup utility (see “Updating the server configuration”).

Connecting the cables

Attention: To prevent damage to equipment, connect cables before you turn on the system-board tray.

All cable connections, other than power, are on the front of the server. See “Operator panel controls, connectors, LEDs, and power” on page 19 for connector locations.

Updating the server configuration

When you start the server for the first time after you add or remove a device, you might receive a message that the configuration has changed. The Setup utility starts automatically so that you can save the new configuration settings. For more information, see Chapter 4, “Configuring the dx360 M2 server,” on page 53.

Some optional devices have device drivers that you must install. For information about installing device drivers, see the documentation that comes with each device.

If the server has an optional RAID adapter and you have installed or removed a hard disk drive, see the documentation that comes with the RAID adapter for information about reconfiguring the disk arrays. For more information about the RAID controller, go to <http://www-304.ibm.com/jct01004c/systems/support/supportsite.wss/docdisplay?Indocid=MIGR-65723&brandind=5000008> or complete the following steps.

Important: Some cluster solutions require specific code levels or coordinated code updates. If the device is part of a cluster solution, verify that the latest level of code is supported for the cluster solution before you update the code.

Note: Changes are made periodically to the IBM Web site. The actual procedure might vary slightly from what is described in this document.

1. Go to <http://www.ibm.com/systems/support/>.
2. Under **Product support**, click **Hardware upgrades**.
3. Under **Product family**, click **RAID**.
4. Under **Type**, click the type of RAID controller that is installed in your server.

For information about configuring the integrated Gigabit Ethernet controller, see “Configuring the Gigabit Ethernet controller” on page 63.

Chapter 4. Configuring the dx360 M2 server

To update the firmware, you might have to use an external USB CD-RW/DVD drive such as the IBM and Lenovo part number 73P4515 or 73P4516. To run the Setup utility or the Dynamic System Analysis (DSA) Preboot diagnostic program, you must have the following additional hardware:

- Monitor
- Combination USB keyboard and pointing device such as IBM part number 40K5372

Optionally, to run the DSA Preboot diagnostic program, you can use a USB flash drive (memory key). A USB flash drive is provided in the accessory carton that comes with the configured rack solution.

The following configuration programs come with the dx360 M2 server:

- **Setup utility**

Use the Setup utility to configure low-level system settings, such as the startup-device sequence, date and time, and passwords. For information about using this program, see “Using the Setup utility” on page 54.
- **Boot Menu program**

The Boot Menu program is part of the UEFI firmware. Use it to override the startup sequence that is set in the Setup utility and temporarily assign a device to be first in the startup sequence. For information about using this program, see “Using the Boot Menu program” on page 59.
- **Integrated management module**

Use the integrated management module (IMM) for configuration, to update the firmware and sensor data record/field replaceable unit (SDR/FRU) data, and to remotely manage a network. For information about using the IMM, see “Using the integrated management module” on page 59.
- **Remote presence capability and blue-screen capture**

The remote presence and blue-screen capture feature are integrated into the integrated management module (IMM). The virtual media key is required to enable these features. When the optional virtual media key is installed in the server, it activates the remote presence functions. Without the virtual media key, you will not be able to access the network remotely to mount or unmount drives or images on the client system. However, you will still be able to access the host graphical user interface through the web interface without the virtual media key. You can order the optional IBM Virtual Media Key, if one did not come with your server. For more information about how to enable the remote presence function, see “Using the remote presence capability and blue-screen capture” on page 60.
- **IBM Advanced Settings Utility (ASU)**

Use ASU to modify firmware settings from the command line without the need to restart the system to access the Setup utility. You can also use ASU to issue selected IMM setup commands. The ASU supports scripting environments through its batch-processing mode. For information about using this program, see “IBM Advanced Settings Utility program” on page 62.
- **Ethernet controller configuration**

For information about configuring the Ethernet controller, see “Configuring the Gigabit Ethernet controller” on page 63.
- **LSI Logic Configuration Utility program**

Some server configurations use the LSI Logic Configuration Utility program to configure an optional LSI RAID controller and the devices that are attached to it. For information about using this program, see “Using the LSI Logic Configuration Utility program” on page 63.

- **ServeRAID configuration program**

Some server configurations use the ServeRAID configuration program to configure an optional ServeRAID controller and the devices that are attached to it. For information about using this program, see “Configuring a ServeRAID controller” on page 65.

- **IBM Electronic Service Agent™**

IBM Electronic Service Agent is a software tool that monitors the server for hardware error events and automatically submits electronic service requests to IBM service and support. Also, it can collect and transmit system configuration information on a scheduled basis so that the information is available to you and your support representative. It uses minimal system resources, is available free of charge, and can be downloaded from the Web. For more information and to download Electronic Service Agent, go to <http://www.ibm.com/support/electronic/>.

- **IBM Dynamic System Analysis (DSA) Preboot Diagnostic Programs**

The IBM Dynamic System Analysis (DSA) Preboot diagnostic programs are the primary method of testing the major components of an IBM System x iDataPlex server. You can use the USB flash drive that comes with the iDataPlex rack when you run the DSA Preboot diagnostic programs on an iDataPlex server.

To download the most current USB or ISO image of the DSA Preboot diagnostic programs go to <http://www.ibm.com/support/docview.wss?uid=psg1SERV-DSA>.

For additional information about the DSA diagnostic programs, see the *Problem Determination and Service Guide* for the iDataPlex server on the IBM *Documentation CD* that comes with the iDataPlex rack solution.

- **IBM Storage Configuration Manager (SCM)**

Use SCM to manage the storage configuration of your virtual environment from a single console. SCM is part of the Virtualization Manager plug-in to IBM Systems Director. For more information and to download the Storage Configuration Manager, go to <http://www.ibm.com/systems/support/>.

- **IBM Systems Director**

IBM Systems Director is a platform-management foundation that streamlines the way you manage physical and virtual systems in a heterogeneous environment. For information about updating IBM Systems Director, see “Updating IBM Systems Director” on page 67.

Using the Setup utility

Use the Setup utility to perform the following tasks:

- View configuration information
- View and change assignments for devices and I/O ports
- Set the date and time
- Set the startup characteristics of the server and the order of startup devices
- Set and change settings for advanced hardware features
- View, set, and change settings for power-management features
- View and clear error logs
- Resolve configuration conflicts

Starting the Setup utility

To start the Setup utility, complete the following steps:

1. Turn on the server.
2. When the prompt <F1> Setup is displayed, press F1. If you have set both a power-on password and an administrator password, you must type the administrator password to access the full Setup utility menu. If you do not type the administrator password, a limited Setup utility menu is available.
3. Select settings to view or change.

Setup utility menu choices

The following choices are on the Setup utility main menu. Depending on the version of the firmware, some menu choices might differ slightly from these descriptions.

- **System Information**

Select this choice to view information about the server. When you make changes through other choices in the Setup utility, some of those changes are reflected in the system information; you cannot change settings directly in the system information.

- **System Summary**

Select this choice to view configuration information, including the ID, speed, and cache size of the microprocessors, machine type and model of the server, the serial number, the system UUID, and the amount of installed memory. When you make configuration changes through other options in the Setup utility, the changes are reflected in the system summary; you cannot change settings directly in the system summary.

- **Product Data**

Select this choice to view the system-board identifier, the revision level or issue date of the firmware, the integrated management module and diagnostics code, and the version and date.

- **System Settings**

Select this choice to view or change the server component settings.

- **Processors**

Select this choice to view or change the processor settings.

- **Memory**

Select this choice to view or change the memory settings. To configure memory mirroring, select **System Settings** → **Memory** , and then select **Memory Channel Mode** → **Mirroring**.

- **Devices and I/O Ports**

Select this choice to view or change assignments for devices and input/output (I/O) ports. You can configure the serial ports; configure remote console redirection; enable or disable integrated Ethernet controllers, the SAS/SATA controller, SATA optical drive channels, and PCI slots; and view the system Ethernet MAC addresses. If you disable a device, it cannot be configured, and the operating system will not be able to detect it (this is equivalent to disconnecting the device).

- **Power**

Select this choice to view or change power capping to control consumption, processors, and performance states.

- **Legacy Support**

Select this choice to view or set legacy support.

- **Force Legacy Video on Boot**
Select this choice to force INT video support, if the operating system does not support UEFI Video Output Standards.
- **Rehook INT**
Select this choice to enable or disable devices from taking control of the boot process. The default is **Disable**.
- **Legacy Thunk Support**
Select this choice to enable or disable legacy thunk support.
- **Integrated Management Module**
Select this choice to view or change the settings for the integrated management module.
 - **POST Watchdog Timer**
Select this choice to view or enable the POST watchdog timer.
 - **POST Watchdog Timer Value**
Select this choice to view or set the POST loader watchdog timer value.
 - **Reboot System on NMI**
Enable or disable restarting the system whenever a nonmaskable interrupt (NMI) occurs. **Disabled** is the default.
 - **Network Configuration**
Select this choice to view the system management network interface port, the IMM MAC address, the current IMM IP address, and host name; define the static IMM IP address, subnet mask, and gateway address; specify whether to use the static IP address or have DHCP assign the IMM IP address; save the network changes; and reset the IMM.
 - **Reset IMM to Defaults**
Select this choice to view or reset IMM to the default settings.
- **Adapters and UEFI Drivers**
Select this choice to view information about the adapters and UEFI drivers in the server.
- **Network**
Select this choice to see all of the device options, such as the iSCSI, PXE, and Ethernet parameters.
- **Storage**
Select this choice to see the Trusted Platform Module (TPM) options.
- **Date and Time**
Select this choice to set the date and time in the server, in 24-hour format (*hour:minute:second*).
- **Start Options**
Select this choice to view or change the start options, including the startup sequence, keyboard NumLock state, PXE boot option, and PCI device boot priority. Changes in the startup options take effect when you start the server.
The startup sequence specifies the order in which the server checks devices to find a boot record. The server starts from the first boot record that it finds. If the server has Wake on LAN hardware and software and the operating system supports Wake on LAN functions, you can specify a startup sequence for the Wake on LAN functions. For example, you can define a startup sequence that checks for a disc in the CD-RW/DVD drive, then checks the hard disk drive, and then checks a network adapter.
This choice is on the full Setup utility menu only.

- **Boot Manager**

Select this choice to view, add, or change the device boot priority, boot from a file, select a one-time boot, or reset the boot order to the default setting.

- **System Event Logs**

Select this choice to enter the System Event Manager, where you can view the error messages in the system event logs. You can use the arrow keys to move between pages in the error log.

The system event logs contain all event and error messages that have been generated during POST, by the systems-management interface handler, and by the system service processor. Run the diagnostic programs to get more information about error codes that occur. See the *Problem Determination and Service Guide* on the IBM *Documentation* CD for instructions for running the diagnostic programs.

Important: If the system-error LED on the front of the server is lit but there are no other error indications, clear the system-event log. Also, after you complete a repair or correct an error, clear the system-event log to turn off the system-error LED on the front of the server.

- **POST Event Viewer**

Select this choice to view the error messages in the POST event viewer.

- **System Event Log**

Select this choice to view the error messages in the system-event log.

- **Clear System Event Log**

Select this choice to clear the system-event log.

- **User Security**

Select this choice to set, change, or clear passwords. See “Passwords” on page 58 for more information.

This choice is on the full and limited Setup utility menu.

- **Set Power-on Password**

Select this choice to set or change a power-on password. For more information, see “Power-on password” on page 58.

- **Clear Power-on Password**

Select this choice to clear a power-on password. For more information, see “Power-on password” on page 58.

- **Set Administrator Password**

Select this choice to set or change an administrator password. An administrator password is intended to be used by a system administrator; it limits access to the full Setup utility menu. If an administrator password is set, the full Setup utility menu is available only if you type the administrator password at the password prompt. For more information, see “Administrator password” on page 58.

- **Clear Administrator Password**

Select this choice to clear an administrator password. For more information, see “Administrator password” on page 58.

- **Save Settings**

Select this choice to save the changes that you have made in the settings.

- **Restore Settings**

Select this choice to cancel the changes that you have made in the settings and restore the previous settings.

- **Load Default Settings**

Select this choice to cancel the changes that you have made in the settings and restore the factory settings.

- **Exit Setup**

Select this choice to exit from the Setup utility. If you have not saved the changes that you have made in the settings, you are asked whether you want to save the changes or exit without saving them.

Passwords

From the **User Security** choice, you can set, change, and delete a power-on password and an administrator password. The **User Security** choice is on the full Setup utility menu only.

If you set only a power-on password, you must type the power-on password to complete the system startup and to have access to the full Setup utility menu.

An administrator password is intended to be used by a system administrator; it limits access to the full Setup utility menu. If you set only an administrator password, you do not have to type a password to complete the system startup, but you must type the administrator password to access the Setup utility menu.

If you set a power-on password for a user and an administrator password for a system administrator, you can type either password to complete the system startup. A system administrator who types the administrator password has access to the full Setup utility menu; the system administrator can give the user authority to set, change, and delete the power-on password. A user who types the power-on password has access to only the limited Setup utility menu; the user can set, change, and delete the power-on password, if the system administrator has given the user that authority.

Power-on password

If a power-on password is set, when you turn on the server, the system startup will not be completed until you type the power-on password. You can use any combination of up to seven characters (A – Z, a – z, and 0 – 9) for the password.

If you forget the power-on password, you can regain access to the server in any of the following ways:

- If an administrator password is set, type the administrator password at the password prompt. Start the Setup utility and reset the power-on password.
- Clear the password by clearing CMOS memory (see the *Problem Determination and Service Guide* for instructions).

Administrator password

An administrator password is intended to be used by a system administrator; it limits access to the full Setup utility menu.

If an administrator password is set, you must type the administrator password for access to the full Setup utility menu. You can use any combination of up to seven characters (A – Z, a – z, and 0 – 9) for the password.

Attention: If you set an administrator password and then forget it, there is no way to change, override, or remove it. You must replace the system board.

Using the Boot Menu program

The Boot Menu program is a built-in, menu-driven configuration utility program that you can use to temporarily redefine the first startup device without changing settings in the Setup utility.

To use the Boot Menu program, complete the following steps:

1. Turn off the server.
2. Restart the server.
3. Press F12 (**Select Boot Device**). If a bootable USB mass storage device is installed, a submenu item (**USB Key/Disk**) is displayed.
4. Use the Up Arrow and Down Arrow keys to select an item from the **Boot Selection Menu** and press Enter.

The next time the server starts, it returns to the startup sequence that is set in the Setup utility.

Starting the backup UEFI firmware

The system board contains a backup copy area for the UEFI (formerly called BIOS) firmware. This is a secondary copy of UEFI firmware that you update only during the process of updating UEFI firmware. If the primary copy of the UEFI firmware becomes damaged, use this backup copy.

To force the server to start from the backup copy, turn off the server; then, place the JP2 jumper in the backup position (pins 2 and 3). See “System-board jumpers” on page 14 for the location of the JP2 jumper.

Use the backup copy of the UEFI firmware until the primary copy is restored. After the primary copy is restored, turn off the server; then, move the JP2 jumper back to the primary position (pins 1 and 2).

Using the integrated management module

The integrated management module (IMM) is a second generation of the functions that were formerly provided by the baseboard management controller hardware. It combines service processor functions, video controller, and (when an optional virtual media key is installed) remote presence function in a single chip.

The IMM supports the following basic systems-management features:

- Environmental monitor with fan speed control for temperature, voltages, fan failure, and power supply failure.
- Diagnostic LEDs to report errors that occur with power supplies, microprocessor, hard disk drives, and system errors.
- DIMM error assistance. The Unified Extensible Firmware Interface (UEFI) disables a failing DIMM that is detected during POST, and the IMM lights the associated system error LED and the failing DIMM error LED.
- System-event log.
- ROM-based IMM firmware flash updates.
- Auto Boot Failure Recovery.
- A virtual media key, which enables full systems-management support (remote video, remote keyboard/mouse, and remote storage).

- When one of the two microprocessors reports an internal error, the server disables the defective microprocessor and restarts with the one good microprocessor.
- NMI detection and reporting.
- SMI handling.
- Automatic Server Restart (ASR) when POST is not complete or the operating system hangs and the OS watchdog timer times out. The IMM might be configured to watch for the OS watchdog timer and reboot the system after a timeout, if the ASR feature is enabled. Otherwise, the IMM allows the administrator to generate an NMI by pressing an NMI button on the system board for an operating-system memory dump. ASR is supported by IPMI.
- Intelligent Platform Management Interface (IPMI) Specification V2.0 and Intelligent Platform Management Bus (IPMB) support.
- Invalid system configuration (CNFG) LED support.
- Serial redirect.
- Serial over LAN (SOL).
- Active Energy Manager.
- Query power-supply input power.
- PECI 2 support.
- Power/reset control (power-on, hard and soft shutdown, hard and soft reset, schedule power control).
- Alerts (in-band and out-of-band alerting, PET traps - IPMI style, SNMP, e-mail).
- Operating-system failure blue screen capture.
- Command-line interface.
- Configuration save and restore.
- PCI configuration data.
- Boot sequence manipulation.

The IMM also provides the following remote server management capabilities through the OSA SMBridge management utility program:

- **Command-line interface (IPMI Shell)**

The command-line interface provides direct access to server management functions through the IPMI 2.0 protocol. Use the command-line interface to issue commands to control the server power, view system information, and identify the server. You can also save one or more commands as a text file and run the file as a script.

- **Serial over LAN**

Establish a Serial over LAN (SOL) connection to manage servers from a remote location. You can remotely view and change the UEFI settings, restart the server, identify the server, and perform other management functions. Any standard Telnet client application can access the SOL connection.

Using the remote presence capability and blue-screen capture

The remote presence and blue-screen capture features are integrated functions of the integrated management module (IMM). When the optional IBM Virtual Media Key is installed in the server, it activates full systems-management functions. The virtual media key is required to enable the integrated remote presence and blue-screen capture features. Without the virtual media key, you cannot remotely mount or unmount drives or images on the client system. However, you still can access the Web interface without the key.

After the virtual media key is installed in the server, it is authenticated to determine whether it is valid. If the key is not valid, you receive a message from the Web interface (when you attempt to start the remote presence feature) indicating that the hardware key is required to use the remote presence feature.

The virtual media key has an LED. When this LED is lit and green, it indicates that the key is installed and functioning correctly.

The remote presence feature provides the following functions:

- Remotely viewing video with graphics resolutions up to 1280 x 1024 at 75 Hz, regardless of the system state
- Remotely accessing the server, using the keyboard and mouse from a remote client
- Mapping the CD or DVD drive, diskette drive, and USB flash drive on a remote client, and mapping ISO and diskette image files as virtual drives that are available for use by the server
- Uploading a diskette image to the IMM memory and mapping it to the server as a virtual drive

The blue-screen capture feature captures the video display contents before the IMM restarts the server when the IMM detects an operating-system hang condition. A system administrator can use the blue-screen capture to assist in determining the cause of the hang condition.

Enabling the remote presence feature

To enable the remote presence feature, complete the following steps:

1. Install the virtual media key into the dedicated slot on the system board (see “Installing an IBM virtual media key” on page 44).
2. Turn on the server.

Note: Approximately 1 to 2 minutes after the server is connected to ac power, the power-control button becomes active.

Obtaining the IP address for the Web interface access

To access the Web interface and use the remote presence feature, you need the IP address for the IMM. You can obtain the IMM IP address through the Setup utility. To locate the IP address, complete the following steps:

1. Turn on the server.

Note: Approximately 1 to 2 minutes after the server is connected to ac power, the power-control button becomes active.

2. When the prompt <F1> Setup is displayed, press F1. (This prompt is displayed on the screen for only a few seconds. You must press F1 quickly.) If you have set both a power-on password and an administrator password, you must type the administrator password to access the full Setup utility menu.
3. From the Setup utility main menu, select **System Settings**.
4. On the next screen, select **Integrated Management Module**.
5. On the next screen, select **Network Configuration**.
6. Find the IP address and write it down.
7. Exit from the Setup utility.

Logging on to the Web interface

To log on to the Web interface to use the remote presence functions, complete the following steps:

1. Open a Web browser and in the **address** or **URL** field, type the IP address or host name of the IMM to which you want to connect.

Notes:

- a. If you are logging in to the IMM for the first time after installation, the IMM defaults to DHCP. If a DHCP host is not available, the IMM uses the default static IP address 192.168.70.125.
- b. You can obtain the DHCP-assigned IP address or the static IP address from the server UEFI or from your network administrator.

The Login page is displayed.

2. Type the user name and password. If you are using the IMM for the first time, you can obtain the user name and password from your system administrator. All login attempts are documented in the event log. A welcome page opens in your browser.

Note: The IMM is set initially with a user name of USERID and password of PASSWORD (passw0rd with a zero, not a the letter O). You have read/write access. For enhanced security, change this default password during your initial configuration.

3. On the Welcome page, type a timeout value (in minutes) in the field that is provided. The IMM will log you off of the Web interface if your browser is inactive for the number of minutes that you entered for the timeout value.
4. Click **Continue** to start the session. The browser opens the System Status page, which gives you a quick view of the server status and the server health summary.

IBM Advanced Settings Utility program

The Advanced Settings Utility (ASU) program is an alternative to the Setup utility for modifying UEFI settings. Use the ASU program online or out of band to modify UEFI settings from the command line without the need to restart the system to access the Setup utility.

You can also use the ASU program to configure the optional remote presence features or other IMM settings. The remote presence features provide enhanced systems-management capabilities.

In addition, the ASU program provides limited settings for configuring the IPMI function in the IMM through the command-line interface.

Use the command-line interface to issue setup commands. You can save any of the settings as a file and run the file as a script. The ASU program supports scripting environments through a batch-processing mode.

For more information and to download the ASU program, go to <http://www.ibm.com/systems/support/>.

Configuring the Gigabit Ethernet controller

The Ethernet controller is integrated on the system board. It provides an interface for connecting to a 10 Mbps, 100 Mbps, or 1 Gbps network and provides full-duplex (FDX) capability, which enables simultaneous transmission and reception of data on the network. If the Ethernet ports in the server support auto-negotiation, the controller detects the data-transfer rate (10BASE-T, 100BASE-TX, or 1000BASE-T) and duplex mode (full-duplex or half-duplex) of the network and automatically operates at that rate and mode.

You do not have to set any jumpers or configure the controller. However, you must install a device driver to enable the operating system to address the controller. For device drivers and information about configuring the Ethernet controller, see the *Intel Ethernet Software CD* that comes with the server. To find updated information about configuring the controller, complete the following steps.

Important: Some cluster solutions require specific code levels or coordinated code updates. If the device is part of a cluster solution, verify that the latest level of code is supported for the cluster solution before you update the code.

Notes:

- Changes are made periodically to the IBM Web site. The actual procedure might vary slightly from what is described in this document.
 - To install the device driver for the Ethernet controller, you might have to use an external USB CD-RW/DVD drive such as the IBM and Lenovo part number 73P4515 or 73P4516. See “Firmware updates” on page 66 for additional instructions about using an external USB CD-RW/DVD drive.
1. Go to <http://www.ibm.com/systems/support/>.
 2. Under **Product support**, click **System x**.
 3. Under **Popular links**, click **Software and device drivers**.
 4. From the **Product family** menu, select **System x iDataPlex dx360 M2 server** and click **Go**.

Using the LSI Logic Configuration Utility program

Use the information in this section to configure an optional LSI RAID controller. If you need to configure an optional ServeRAID controller, see “Configuring a ServeRAID controller” on page 65.

Use the LSI Logic Configuration Utility program to configure and manage redundant array of independent disks (RAID) arrays. Be sure to use the program as described in this document. Use the LSI Logic Configuration Utility program to perform the following tasks:

- Perform a low-level format of a SCSI hard disk drive
- View or change SCSI IDs for attached devices
- Set a SCSI device scan order
- Set SCSI protocol parameters on SCSI hard disk drives
- Configure arrays
- View your RAID configuration and associated devices
- Monitor operation of your RAID controllers
- Create a mirrored pair of SCSI hard disk drives with or without a hot-spare drive

The integrated SCSI controller with RAID capabilities supports redundant array of independent disks (RAID) arrays. You can use the LSI Logic Configuration Utility program to configure RAID level-1 for a single pair of attached devices. If you install a different type of RAID adapter, follow the instructions in the documentation that comes with the adapter to view or change SCSI settings for attached devices.

You can download an LSI command-line configuration program (CFG1030) from <http://www.ibm.com/systems/support/>. For more information about the RAID controller, go to <http://www-304.ibm.com/jct01004c/systems/support/supportsite.wss/docdisplay?Indocid=MIGR-65723&brandind=5000008> or complete the following steps.

Note: Changes are made periodically to the IBM Web site. The actual procedure might vary slightly from what is described in this document.

1. Go to <http://www.ibm.com/systems/support/>.
2. Under **Product support**, click **Hardware upgrades**.
3. Under **Product family**, click **RAID**.
4. Under **Type**, click on the type of RAID controller that is installed in your server.

When you use the LSI Logic Configuration Utility program to configure and manage arrays, review the following information:

- The integrated SCSI controller with RAID capabilities in the server supports only RAID level-1 with a hot-spare drive installed. Installing an optional ServerRAID controller provides additional RAID levels.
- When you create a RAID level-1 (mirrored) pair, all drives must be on the same channel.
- Hard disk drive capacities affect how you create arrays. The drives in an array can have different capacities, but the RAID controller treats them as if they all have the capacity of the smallest hard disk drive.
- You can set up a mirror after the operating system is installed on the primary drive only if you are using an integrated SCSI controller with RAID capabilities. You must make sure that the primary drive has the lower SCSI ID (for example, 0).

Important: If you use an integrated SCSI controller with RAID capabilities to configure a RAID level-1 (mirrored) array after you have installed the operating system, you will lose access to any data or applications that were previously stored on the secondary drive of the mirrored pair.

- If you install a different type of RAID controller, follow the instructions in the documentation that comes with the controller to view or change SCSI settings for attached devices.

The following sections provide instructions for starting the LSI Logic Configuration Utility program and performing selected functions.

Starting the LSI Logic Configuration Utility program

To start the LSI Logic Configuration Utility program, complete the following steps:

1. Turn on the server.
2. When the prompt <<< Press <CTRL><C> to start LSI Logic Configuration Utility >>> is displayed, press Ctrl+C. If you have set an administrator password, you are prompted to type the password.

3. To select a controller (channel) from the list of adapters, use the arrow keys and press Enter.
4. To change the settings of the selected items, follow the instructions on the screen. If you select **Device Properties** or **Mirroring Properties**, additional screens are displayed.

When you have finished changing settings, press Esc to exit from the program; select **Save** to save the settings that you have changed.

Formatting a SCSI hard disk drive

Low-level formatting removes all data from the hard disk. If there is data on the disk that you want to save, back up the hard disk before you perform this procedure.

Note: Before you format a SCSI hard disk, make sure that the disk is not part of a mirrored pair. From the list of adapters, select the controller (channel) for the drive that you want to format. Select **Mirroring Properties** and make sure that the mirroring value for the drive is **None**.

To format a drive, complete the following steps:

1. From the list of adapters, select the controller (channel) for the drive that you want to format.
2. Select **Device Properties**.
3. To highlight the drive that you want to format, use the Up Arrow and Down Arrow keys. To scroll left and right, use the Left Arrow and Right Arrow keys or the End key.
4. To start the low-level formatting operation, select **Format** and press Enter.

Creating a mirrored pair of SCSI hard disk drives

To create a mirrored pair of SCSI hard disk drives, complete the following steps:

1. From the list of adapters, select the controller (channel) for the drives that you want to mirror.
2. Select **Mirroring Properties**.
3. Use the arrow keys to highlight the first drive in the pair; then, press the Minus key to change the mirroring value to **Primary**.
4. Use the arrow keys to highlight the second drive in the pair; then, press the Minus key to change the mirroring value to **Secondary**.
5. To establish a third drive that will take over the function of either mirrored drive in the event of a failure, use the arrow keys to highlight the drive that you want to use for that purpose; then, press the Minus key to change the mirroring value to **Hot Spare**.

Configuring a ServeRAID controller

Use the information in this section to configure an optional ServeRAID controller. If you need to configure an optional LSI RAID controller, see “Using the LSI Logic Configuration Utility program” on page 63.

Important: Some cluster solutions require specific code levels or coordinated code updates. If the device is part of a cluster solution, verify that the latest level of code is supported for the cluster solution before you update the code.

To update the firmware and UEFI code for an optional ServeRAID controller, you must use the IBM *ServeRAID Support* CD that comes with the controller.

Note: To update the firmware and UEFI code for an optional ServeRAID controller, you might have to use an external USB CD-RW/DVD drive such as the IBM and Lenovo part number 73P4515 or 73P4516. See “Firmware updates” for additional instructions about using an external USB CD-RW/DVD drive.

For more information about the ServeRAID controller, go to <http://www-304.ibm.com/jct01004c/systems/support/supportsite.www/docdisplay?Indocid=MIGR-4JTS2T&brandind=5000008> or complete the following steps.

Note: Changes are made periodically to the IBM Web site. The actual procedure might vary slightly from what is described in this document.

1. Go to <http://www.ibm.com/systems/support/>.
2. Under **Product support**, click **Hardware upgrades**.
3. Under **Product family**, click **RAID**.
4. Under **Type**, click on the type of RAID controller that is installed in your server.

Firmware updates

Important: Some cluster solutions require specific code levels or coordinated code updates. If the device is part of a cluster solution, verify that the latest level of code is supported for the cluster solution before you update the code.

The firmware for the server is periodically updated and is available for download from the Web. To check for the latest level of firmware, such as BIOS code, vital product data (VPD) code, device drivers, and service processor firmware complete the following steps.

Note: Changes are made periodically to the IBM Web site. The actual procedure might vary slightly from what is described in this document.

1. Go to <http://www.ibm.com/systems/support/>.
2. Under **Product support**, click **System x**.
3. Under **Popular links**, click **Software and device drivers**.
4. Click **System x iDataPlex dx360 M2 server** to display the matrix of downloadable files.

Download the latest firmware for the server; then, install the firmware, using the instructions that are included with the downloaded files.

When you replace a device in the server, you might have to either update the server with the latest version of the firmware that is stored in memory on the device or restore the pre-existing firmware from a diskette or CD image.

- UEFI code is stored in ROM on the system board.
- IMM firmware is stored in ROM on the integrated management controller on the system board.
- Ethernet firmware is stored in ROM on the Ethernet controller.
- ServeRAID firmware is stored in ROM on the ServeRAID SAS controller.
- SAS firmware is stored in ROM on the ServeRAID SAS controller.
- Major components contain vital product data (VPD) code. You can select to update the VPD code during the UEFI code update procedure.

The following items are downloadable at <http://www.ibm.com/systems/support/>:

- Diagnostics programs
- IMM firmware
- Ethernet firmware

Important: To avoid problems and to maintain proper system performance, always make sure that the UEFI code, service processor, and other firmware levels are consistent for all iDataPlex servers.

To update the firmware, you might have to use an external USB CD-RW/DVD drive such as the IBM and Lenovo part number 73P4515 or 73P4516. To use an external USB CD-RW/DVD drive to update the firmware, complete the following steps:

1. If the system-board tray is running, turn off the system-board tray and all attached devices.
2. Connect a USB CD or DVD drive to a USB connector on the front of the system-board tray.
3. Turn on all attached devices; then, turn on the system-board tray.
4. When the prompt <F1> Setup is displayed, press F1.
5. From the Setup utility menu, select **Startup Options**.
6. Note the device that is selected as the first startup device. Later, you must restore this setting.
7. Select **CD/DVD-ROM** as the first startup device.
8. Press Esc to return to the Setup utility menu.
9. Insert the CD or DVD containing the firmware update into the CD or DVD drive.
10. Select **Save Changes and Exit** and follow the prompts.

Updating IBM Systems Director

If you plan to use IBM Systems Director to manage the server, you must check for the latest applicable IBM Systems Director updates and interim fixes.

To locate and install a newer version of IBM Systems Director, complete the following steps:

Notes:

- Changes are made periodically to the IBM Web site. The actual procedure might vary slightly from what is described in this document.
 - To update IBM Systems Director software, you might have to use an external USB CD-RW/DVD drive such as the IBM and Lenovo part number 73P4515 or 73P4516. See “Firmware updates” on page 66 for additional instructions about using an external USB CD-RW/DVD drive.
1. Check for the latest version of IBM Systems Director:
 - a. Go to <http://www.ibm.com/systems/management/director/downloads.html>.
 - b. If a newer version of IBM Systems Director than what comes with the server is shown in the drop-down list, follow the instructions on the Web page to download the latest version.
 2. Install the IBM Systems Director program.

If your management server is connected to the Internet, to locate and install updates and interim fixes, complete the following steps:

1. Make sure that you have run the Discovery and Inventory collection tasks.
2. On the Welcome page of the IBM Systems Director Web interface, click **View updates**.
3. Click **Check for updates**. The available updates are displayed in a table.
4. Select the updates that you want to install, and click **Install** to start the installation wizard.

If your management server is not connected to the Internet, to locate and install updates and interim fixes, complete the following steps:

1. Make sure that you have run the Discovery and Inventory collection tasks.
2. On a system that is connected to the Internet, go to <http://www.ibm.com/eserver/support/fixes/fixcentral/>.
3. From the **Product family** list, select **IBM Systems Director**.
4. From the **Product** list, select **IBM Systems Director**.
5. From the **Installed version** list, select the latest version, and click **Continue**.
6. Download the available updates.
7. Copy the downloaded files to the management server.
8. On the management server, on the Welcome page of the IBM Systems Director Web interface, click the **Manage** tab, and click **Update Manager**.
9. Click **Import updates** and specify the location of the downloaded files that you copied to the management server.
10. Return to the Welcome page of the Web interface, and click **View updates**.
11. Select the updates that you want to install, and click **Install** to start the installation wizard.

Appendix A. Getting help and technical assistance

If you need help, service, or technical assistance or just want more information about IBM products, you will find a wide variety of sources available from IBM to assist you. This section contains information about where to go for additional information about IBM and IBM products, what to do if you experience a problem with your system, and whom to call for service, if it is necessary.

Before you call

Before you call, make sure that you have taken these steps to try to solve the problem yourself:

- Check all cables to make sure that they are connected.
- Check the power switches to make sure that the system and any optional devices are turned on.
- Use the troubleshooting information in your system documentation, and use the diagnostic tools that come with your system. Information about diagnostic tools is in the *Problem Determination and Service Guide* on the *IBM Documentation CD* that comes with your system.
- Go to the IBM support Web site at <http://www.ibm.com/systems/support/> to check for technical information, hints, tips, and new device drivers or to submit a request for information.

You can solve many problems without outside assistance by following the troubleshooting procedures that IBM provides in the online help or in the documentation that is provided with your IBM product. The documentation that comes with IBM systems also describes the diagnostic tests that you can perform. Most systems, operating systems, and programs come with documentation that contains troubleshooting procedures and explanations of error messages and error codes. If you suspect a software problem, see the documentation for the operating system or program.

Using the documentation

Information about your IBM system and preinstalled software, if any, or optional device is available in the documentation that comes with the product. That documentation can include printed documents, online documents, readme files, and help files. See the troubleshooting information in your system documentation for instructions for using the diagnostic programs. The troubleshooting information or the diagnostic programs might tell you that you need additional or updated device drivers or other software. IBM maintains pages on the World Wide Web where you can get the latest technical information and download device drivers and updates. To access these pages, go to <http://www.ibm.com/systems/support/> and follow the instructions. Also, some documents are available through the IBM Publications Center at <http://www.ibm.com/shop/publications/order/>.

Getting help and information from the World Wide Web

On the World Wide Web, the IBM Web site has up-to-date information about IBM systems, optional devices, services, and support. The address for IBM System x and xSeries information is <http://www.ibm.com/systems/x/>. The address for IBM iDataPlex information is <http://www.ibm.com/systems/x/hardware/idadaplex/index.html>. The address for IBM BladeCenter information is <http://www.ibm.com/systems/bladecenter/>.

You can find service information for IBM systems and optional devices at <http://www.ibm.com/systems/support/>.

Software service and support

Through IBM Support Line, you can get telephone assistance, for a fee, with usage, configuration, and software problems with System x and xSeries servers, BladeCenter products, IntelliStation® workstations, and appliances. For information about which products are supported by Support Line in your country or region, see <http://www.ibm.com/services/sl/products/>.

For more information about Support Line and other IBM services, see <http://www.ibm.com/services/>, or see <http://www.ibm.com/planetwide/> for support telephone numbers. In the U.S. and Canada, call 1-800-IBM-SERV (1-800-426-7378).

Hardware service and support

You can receive hardware service through your IBM reseller or IBM Services. To locate a reseller authorized by IBM to provide warranty service, go to <http://www.ibm.com/partnerworld/> and click **Find a Business Partner** on the right side of the page. For IBM support telephone numbers, see <http://www.ibm.com/planetwide/>. In the U.S. and Canada, call 1-800-IBM-SERV (1-800-426-7378).

In the U.S. and Canada, hardware service and support is available 24 hours a day, 7 days a week. In the U.K., these services are available Monday through Friday, from 9 a.m. to 6 p.m.

IBM Taiwan product service

台灣 IBM 產品服務聯絡方式：
台灣國際商業機器股份有限公司
台北市松仁路 7 號 3 樓
電話：0800-016-888

IBM Taiwan product service contact information:
IBM Taiwan Corporation
3F, No 7, Song Ren Rd.
Taipei, Taiwan
Telephone: 0800-016-888

Appendix B. Notices

This information was developed for products and services offered in the U.S.A.

IBM may not offer the products, services, or features discussed in this document in other countries. Consult your local IBM representative for information on the products and services currently available in your area. Any reference to an IBM product, program, or service is not intended to state or imply that only that IBM product, program, or service may be used. Any functionally equivalent product, program, or service that does not infringe any IBM intellectual property right may be used instead. However, it is the user's responsibility to evaluate and verify the operation of any non-IBM product, program, or service.

IBM may have patents or pending patent applications covering subject matter described in this document. The furnishing of this document does not give you any license to these patents. You can send license inquiries, in writing, to:

*IBM Director of Licensing
IBM Corporation
North Castle Drive
Armonk, NY 10504-1785
U.S.A.*

INTERNATIONAL BUSINESS MACHINES CORPORATION PROVIDES THIS PUBLICATION "AS IS" WITHOUT WARRANTY OF ANY KIND, EITHER EXPRESS OR IMPLIED, INCLUDING, BUT NOT LIMITED TO, THE IMPLIED WARRANTIES OF NON-INFRINGEMENT, MERCHANTABILITY OR FITNESS FOR A PARTICULAR PURPOSE. Some states do not allow disclaimer of express or implied warranties in certain transactions, therefore, this statement may not apply to you.

This information could include technical inaccuracies or typographical errors. Changes are periodically made to the information herein; these changes will be incorporated in new editions of the publication. IBM may make improvements and/or changes in the product(s) and/or the program(s) described in this publication at any time without notice.

Any references in this information to non-IBM Web sites are provided for convenience only and do not in any manner serve as an endorsement of those Web sites. The materials at those Web sites are not part of the materials for this IBM product, and use of those Web sites is at your own risk.

IBM may use or distribute any of the information you supply in any way it believes appropriate without incurring any obligation to you.

Trademarks

IBM, the IBM logo, and [ibm.com](http://www.ibm.com)[®] are trademarks or registered trademarks of International Business Machines Corporation in the United States, other countries, or both. If these and other IBM trademarked terms are marked on their first occurrence in this information with a trademark symbol ([®] or [™]), these symbols indicate U.S. registered or common law trademarks owned by IBM at the time this information was published. Such trademarks may also be registered or common law trademarks in other countries. A current list of IBM trademarks is available on the Web at "Copyright and trademark information" at <http://www.ibm.com/legal/copytrade.shtml>.

Adobe and PostScript are either registered trademarks or trademarks of Adobe Systems Incorporated in the United States and/or other countries.

Cell Broadband Engine is a trademark of Sony Computer Entertainment, Inc., in the United States, other countries, or both and is used under license therefrom.

Intel, Intel Xeon, Itanium, and Pentium are trademarks or registered trademarks of Intel Corporation or its subsidiaries in the United States and other countries.

Java and all Java-based trademarks are trademarks of Sun Microsystems, Inc., in the United States, other countries, or both.

Linux is a registered trademark of Linus Torvalds in the United States, other countries, or both.

Microsoft, Windows, and Windows NT are trademarks of Microsoft Corporation in the United States, other countries, or both.

UNIX is a registered trademark of The Open Group in the United States and other countries.

Other company, product, or service names may be trademarks or service marks of others.

Important notes

Processor speed indicates the internal clock speed of the microprocessor; other factors also affect application performance.

CD or DVD drive speed is the variable read rate. Actual speeds vary and are often less than the possible maximum.

When referring to processor storage, real and virtual storage, or channel volume, KB stands for 1024 bytes, MB stands for 1 048 576 bytes, and GB stands for 1 073 741 824 bytes.

When referring to hard disk drive capacity or communications volume, MB stands for 1 000 000 bytes, and GB stands for 1 000 000 000 bytes. Total user-accessible capacity can vary depending on operating environments.

Maximum internal hard disk drive capacities assume the replacement of any standard hard disk drives and population of all hard disk drive bays with the largest currently supported drives that are available from IBM.

Maximum memory might require replacement of the standard memory with an optional memory module.

IBM makes no representation or warranties regarding non-IBM products and services that are ServerProven[®], including but not limited to the implied warranties of merchantability and fitness for a particular purpose. These products are offered and warranted solely by third parties.

IBM makes no representations or warranties with respect to non-IBM products. Support (if any) for the non-IBM products is provided by the third party, not IBM.

Some software might differ from its retail version (if available) and might not include user manuals or all program functionality.

German Ordinance for Work gloss statement

The product is not suitable for use with visual display work place devices according to clause 2 of the German Ordinance for Work with Visual Display Units.

Das Produkt ist nicht für den Einsatz an Bildschirmarbeitsplätzen im Sinne § 2 der Bildschirmarbeitsverordnung geeignet.

Electronic emission notices

Federal Communications Commission (FCC) statement

Note: This equipment has been tested and found to comply with the limits for a Class A digital device, pursuant to Part 15 of the FCC Rules. These limits are designed to provide reasonable protection against harmful interference when the equipment is operated in a commercial environment. This equipment generates, uses, and can radiate radio frequency energy and, if not installed and used in accordance with the instruction manual, may cause harmful interference to radio communications. Operation of this equipment in a residential area is likely to cause harmful interference, in which case the user will be required to correct the interference at his own expense.

Properly shielded and grounded cables and connectors must be used in order to meet FCC emission limits. IBM is not responsible for any radio or television interference caused by using other than recommended cables and connectors or by unauthorized changes or modifications to this equipment. Unauthorized changes or modifications could void the user's authority to operate the equipment.

This device complies with Part 15 of the FCC Rules. Operation is subject to the following two conditions: (1) this device may not cause harmful interference, and (2) this device must accept any interference received, including interference that may cause undesired operation.

Industry Canada Class A emission compliance statement

This Class A digital apparatus complies with Canadian ICES-003.

Avis de conformité à la réglementation d'Industrie Canada

Cet appareil numérique de la classe A est conforme à la norme NMB-003 du Canada.

Australia and New Zealand Class A statement

Attention: This is a Class A product. In a domestic environment this product may cause radio interference in which case the user may be required to take adequate measures.

United Kingdom telecommunications safety requirement

Notice to Customers

This apparatus is approved under approval number NS/G/1234/J/100003 for indirect connection to public telecommunication systems in the United Kingdom.

European Union EMC Directive conformance statement

This product is in conformity with the protection requirements of EU Council Directive 2004/108/EC on the approximation of the laws of the Member States relating to electromagnetic compatibility. IBM cannot accept responsibility for any failure to satisfy the protection requirements resulting from a nonrecommended modification of the product, including the fitting of non-IBM option cards.

This product has been tested and found to comply with the limits for Class A Information Technology Equipment according to CISPR 22/European Standard EN 55022. The limits for Class A equipment were derived for commercial and industrial environments to provide reasonable protection against interference with licensed communication equipment.

Attention: This is a Class A product. In a domestic environment this product may cause radio interference in which case the user may be required to take adequate measures.

European Community contact:
IBM Technical Regulations
Pascalstr. 100, Stuttgart, Germany 70569
Telephone: 0049 (0)711 785 1176
Fax: 0049 (0)711 785 1283
E-mail: tjahn@de.ibm.com

Taiwanese Class A warning statement

警告使用者：
這是甲類的資訊產品，在
居住的環境中使用時，可
能會造成射頻干擾，在這
種情況下，使用者會被要
求採取某些適當的對策。

Chinese Class A warning statement

声 明
此为 A 级产品。在生活环境中，
该产品可能会造成无线电干扰。
在这种情况下，可能需要用户对其
干扰采取切实可行的措施。

Japanese Voluntary Control Council for Interference (VCCI) statement

この装置は、クラス A 情報技術装置です。この装置を家庭環境で使用すると電波妨害を引き起こすことがあります。この場合には使用者が適切な対策を講ずるよう要求されることがあります。

VCCI-A

Korean Class A warning statement

이 기기는 업무용으로 전자파 적합등록을 받은 기기
이오니, 판매자 또는 사용자는 이점을 주의하시기
바라며, 만약 잘못 구입하셨을 때에는 구입한 곳에
서 비업무용으로 교환하시기 바랍니다.

Index

Numerics

- 2U chassis
 - removing expansion enclosure 25
 - removing system-board tray 25
- 3U chassis
 - installing 50
 - removing 24
 - removing system-board tray 27

A

- adapter
 - connector locations 32
 - features 6
 - installing 32
- administrator password 57
- assistance, getting 69
- attention notices 4
- availability 8

B

- blue-screen capture 7
- blue-screen capture feature
 - overview 61
- boot manager 59

C

- cable connection 51
- caution statements 4
- chassis features 15
- Class A electronic emission notice 73
- components
 - chassis 15
 - system board 13
 - system-board tray 12
- configuration programs 53
- configuring
 - Ethernet controller 63
 - integrated management module settings 62
 - RAID 63
- connecting cables 51
- connectors 19, 21
 - memory 13
 - microprocessor 13
 - SATA hard disk drives 13
 - system board 13
- controls 19
- creating a mirrored pair of hard disk drives 65

D

- danger statements 4
- device drivers 9

- DIMMs
 - connector locations 41
 - installing 40
 - memory mirroring 41
 - order of installation 41
- documentation CD 3
- drive
 - connectors 13
 - specifications 6

E

- electronic emission Class A notice 73
- Ethernet 6, 7
- Ethernet connector 20
- Ethernet controller, configuring 63
- Ethernet transmit/receive activity LED 20
- expansion enclosure
 - installing 46
 - removing 25, 29

F

- FCC Class A notice 73
- features and specifications
 - electrical input 5
 - environment 5
 - expansion slots 5
 - hard disk drives 5
 - integrated management module 5
 - memory 5
 - microprocessor 5
 - server 5
 - size 5
- firmware update 66
- formatting a hard disk drive 65

G

- getting help 69
- gloss statement (Germany) 73

H

- hard disk drive
 - activity LED 20
 - installing
 - 2.5-inch hot-swap 38
 - 2.5-inch simple-swap 39
 - 3.5-inch hot-swap 36
 - 3.5-inch simple-swap 37
 - removing
 - 2.5-inch hot-swap 31
 - 2.5-inch simple-swap 32
 - 3.5-inch hot-swap 30
 - 3.5-inch simple-swap 30
 - specifications 5

hardware service and support 70
help, getting 69

I

IBM Support Line 70
IBM Systems Director 8, 67
iDataPlex rack
 installing 3U chassis 50
 removing 3U chassis 24
important notices 4
installation guidelines 23
installing
 2.5-inch simple-swap solid-state drive 39
 3U chassis 50
 adapter 32
 expansion enclosure 46
 hard disk drive
 2.5-inch hot-swap 38
 2.5-inch simple-swap 39
 3.5-inch hot-swap 36
 3.5-inch simple-swap 37
 memory module 40
 system-board tray 47, 48
 system-board tray cover 45
 virtual media key 44
integrated functions 5
integrated management module
 configuration 62
 description 6
introduction 1
IP address
 obtaining for web-based interface access 61

J

jumpers
 system board 14

L

LEDs 19
link LED 20
local area network (LAN) 6
Locator (location) LED 20
LSI Logic Configuration Utility program 63
 starting 64

M

memory module
 connector locations 41
 installing 40
 memory mirroring 40
 online-spare memory 40
 specifications 5
microprocessor
 connector location 13
 specifications 5

N

notes 4
notes, important 72
notices 71
 electronic emission 73
 FCC, Class A 73
notices and statements 4

O

obtaining
 the IP address for web-based interface access 61
overview 6

P

password 58
 administrator 58
 power-on 58
PCI
 connector locations 32
 expansion slots 5
 installing 32
power LED 20
power-control button 19
power-cord connector 21
power-on password 57
publications 2

R

RAID configuration 63
RAS features 8
reliability 8
remote presence capability 7
remote presence feature
 using 60
removing
 2.5-inch simple-swap solid-state drive 32
 3U chassis 24
 expansion enclosure 25, 29
 hard disk drive
 2.5-inch hot-swap 31
 2.5-inch simple-swap 32
 3.5-inch hot-swap 30
 3.5-inch simple-swap 30
 system-board tray 25, 27
 system-board tray cover 28

S

serial connector 20
serial number, location 1
server configuration update 51
server features and specifications 5
server hardware configurations 17
ServeRAID 7
serviceability 8
Setup utility 54
SMP 7

- software service and support 70
- solid-state drive
 - installing 2.5-inch simple-swap 39
 - removing 2.5-inch simple-swap 32
- specifications 5
- statements and notices 4
- static-sensitive device handling 24
- stopping the system-board tray 21
- support, web site 69
- symmetric multiprocessing 7
- system board
 - jumpers 14
- system board layouts 12
- system reliability guidelines 23
- system-board connectors 12, 13
- system-board tray
 - installing 47, 48
 - removing 25, 27
- system-board tray cover
 - installing 45
 - removing 28
- system-error LED 20
- systems management 7, 8

T

- telephone numbers 70
- trademarks 71
- turning off the system-board tray 21
- turning on the system-board tray 21
- TÜV gloss statement 73

U

- UEFI , backup firmware 59
- United States electronic emission Class A notice 73
- United States FCC Class A notice 73
- update server configuration 51
- UpdateXpress System Packs 9
- updating firmware 66
- USB connector 19
- using
 - the remote presence feature 60
- utility program
 - Advanced Settings Utility program 62
 - Setup utility 54

V

- video connector 20
- virtual media key
 - description 7
 - installing 44

W

- web site
 - publication ordering 69
 - support 69
 - support line, telephone numbers 70



Part Number: 69Y3928

Printed in USA

(1P) P/N: 69Y3928

