



# Lenovo Flex System x440 Compute Node Installation and Service Guide



**Machine Types:** 7167, 2590

## **Note**

Before using this information and the product it supports, read the general information in Appendix B “Notices” on page 897, the *Warranty Information* document, and the *Safety Information* and the *Environmental Notices and User Guide* documents on the *Lenovo Documentation CD*.

**Fourth Edition (December 2018)**

© Copyright Lenovo 2014, 2018.

**LIMITED AND RESTRICTED RIGHTS NOTICE:** If data or software is delivered pursuant a General Services Administration “GSA” contract, use, reproduction, or disclosure is subject to restrictions set forth in Contract No. GS-35F-05925

---

# Contents

|   |             |
|---|-------------|
| <b>Safety</b> . . . . .   | <b>.iii</b> |
| Safety statements . . . . .   | iv          |
| <b>Chapter 1. Introduction</b> . . . . .  | <b>1</b>    |
| Related documentation . . . . .   | 2           |
| Brocade documentation . . . . .   | 3           |
| The Lenovo Documentation CD . . . . .   | 3           |
| Hardware and software requirements . . . . .  | 3           |
| Using the Documentation Browser . . . . .   | 3           |
| Notices and statements in this document . . . . .                                       | 4           |
| Features and specifications . . . . .   | 5           |
| What your compute node offers . . . . .   | 7           |
| Lenovo XClarity Administrator . . . . .   | 11          |
| Reliability, availability, and serviceability features . . . . .                        | 12          |
| Major components of the compute node . . . . .  | 13          |
| Power, controls, and indicators . . . . .   | 13          |
| Compute node controls, connectors, and LEDs . . . . .                                   | 13          |
| Console breakout cable . . . . .  | 16          |
| Turning on the compute node . . . . .   | 16          |
| Turning off the compute node . . . . .  | 17          |
| System-board layouts . . . . .  | 18          |
| System-board connectors . . . . .   | 18          |
| System-board jumpers . . . . .  | 18          |
| System-board LEDs . . . . .   | 19          |
| System-board switches . . . . .   | 20          |
| <b>Chapter 2. Configuring</b> . . . . .   | <b>23</b>   |
| Updating firmware and device drivers . . . . .  | 23          |
| Recovering a UEFI image . . . . .   | 24          |
| Configuring the compute node . . . . .  | 25          |
| Using the Setup utility . . . . .   | 26          |
| Setting the boot protocol to boot from legacy devices using the Setup utility . . . . . | 31          |
| Using the Boot Selection Menu program . . . . .   | 32          |
| Updating the Universally Unique Identifier and DMI/SMBIOS data . . . . .                | 32          |
| Configuring a RAID array . . . . .  | 35          |
| Using the LSI Logic Configuration Utility . . . . .                                     | 36          |
| Setting up the LAN-on-motherboard (LOM) feature . . . . .                               | 36          |
| <b>Chapter 3. Installing the operating system</b> . . . . .                             | <b>39</b>   |
| Using the ServerGuide Setup and Installation CD . . . . .                               | 40          |
| ServerGuide features . . . . .  | 40          |

|   |           |
|---|-----------|
| Typical operating-system installation . . . . .                     | 41        |
| Installing the operating system without using ServerGuide . . . . . | 41        |
| Using Lenovo ServerGuide Scripting Toolkit. . . . .                 | 41        |
| <b>Chapter 4. Accessing the IMM2.</b> . . . .                       | <b>43</b> |
| Accessing the IMM2 remotely . . . . .                               | 43        |
| Viewing the network access tag. . . . .                             | 43        |
| Logging in to the web interface . . . . .                           | 44        |
| IMM2 action descriptions . . . . .                                  | 45        |
| Accessing the IMM2 using the LAN over USB interface. . . . .        | 48        |
| Potential conflicts with the LAN over USB interface . . . . .       | 48        |
| Resolving conflicts with the IMM2 LAN over USB interface . . . . .  | 48        |
| Configuring the LAN over USB interface . . . . .                    | 49        |
| <b>Chapter 5. Parts listing, Types 7167 and 2590</b> . . . . .      | <b>51</b> |
| <b>Chapter 6. Troubleshooting</b> . . . . .                         | <b>57</b> |
| Service bulletins . . . . .   | 57        |
| Diagnostic tools. . . . .   | 57        |
| Light path diagnostics . . . . .                                    | 57        |
| IMM event log. . . . .  | 63        |
| Viewing event logs through the Setup utility . . . . .              | 63        |
| Viewing event logs without restarting the compute node . . . . .    | 63        |
| Lenovo Dynamic System Analysis Preboot diagnostic program . . . . . | 65        |
| DSA diagnostic test results . . . . .                               | 66        |
| Event messages . . . . .  | 202       |
| IMM messages . . . . .  | 202       |
| UEFI diagnostic codes . . . . .                                     | 775       |
| Troubleshooting by symptom . . . . .                                | 799       |
| Compute node start problems . . . . .                               | 799       |
| Connectivity problems . . . . .                                     | 800       |
| Hard disk drive problems . . . . .                                  | 814       |
| Intermittent problems. . . . .                                      | 814       |
| Intermittent connectivity problems. . . . .                         | 815       |
| Memory problems . . . . .   | 816       |
| Observable problems. . . . .  | 817       |
| Optional device and FRU installation problems . . . . .             | 819       |
| Performance problems . . . . .                                      | 820       |
| Power-on problems . . . . .   | 821       |
| Software problems. . . . .  | 824       |

|   |     |
|---|-----|
| Solving undetermined problems . . . . . | 824 |
| Collecting service data . . . . .       | 825 |

**Chapter 7. Installing, removing, and replacing compute node components . . . . .827**

|   |     |
|---|-----|
| Installing an optional device . . . . .                                   | 827 |
| Installation guidelines . . . . .   | 827 |
| System reliability guidelines . . . . .                                   | 827 |
| Handling static-sensitive devices . . . . .                               | 828 |
| Returning a device or component . . . . .                                 | 828 |
| Updating the compute node configuration . . . . .                         | 828 |
| Removing a compute node from a chassis . . . . .                          | 828 |
| Installing a compute node in a chassis . . . . .                          | 829 |
| Removing and replacing Tier 1 customer replaceable units (CRUs) . . . . . | 831 |
| Removing the adapter-retention assembly . . . . .                         | 831 |
| Installing the adapter-retention assembly . . . . .                       | 832 |
| Removing the bezel . . . . .  | 833 |
| Installing the bezel . . . . .  | 834 |
| Removing the CMOS battery . . . . .                                       | 834 |
| Installing the CMOS battery . . . . .                                     | 835 |
| Removing the compute node cover . . . . .                                 | 836 |
| Installing the compute node cover . . . . .                               | 838 |
| Removing a DIMM . . . . .   | 839 |
| Installing a DIMM . . . . .   | 840 |
| Removing the front handle . . . . .                                       | 852 |
| Installing the front handles . . . . .                                    | 852 |
| Removing the hard disk drive backplane . . . . .                          | 853 |
| Installing the hard disk drive backplane . . . . .                        | 855 |
| Removing a hot-swap hard disk drive . . . . .                             | 856 |
| Installing a hot-swap hard disk drive . . . . .                           | 856 |
| Removing an I/O expansion adapter . . . . .                               | 857 |
| Installing an I/O expansion adapter . . . . .                             | 858 |
| Removing the light path diagnostics panel . . . . .                       | 859 |
| Installing the light path diagnostics panel . . . . .                     | 860 |
| Removing the USB flash drive . . . . .                                    | 861 |
| Installing the USB flash drive . . . . .                                  | 862 |
| Removing and replacing Tier 2 customer replaceable units (CRUs) . . . . . | 863 |
| Removing and replacing the base assembly . . . . .                        | 863 |
| Removing the chassis bulkhead. . . . .                                    | 871 |
| Installing the chassis bulkhead . . . . .                                 | 872 |
| Removing the hard disk drive cage . . . . .                               | 873 |
| Installing the hard disk drive cage . . . . .                             | 873 |
| Removing a fabric connector . . . . .                                     | 874 |
| Installing a fabric connector . . . . .                                   | 875 |

|  |     |
|--|-----|
| Removing a microprocessor and heat sink . . . . .        | 876 |
| Installing a microprocessor and heat sink . . . . .      | 880 |
| Thermal grease . . . . .                                 | 888 |
| Removing a microprocessor-retention assembly . . . . .   | 889 |
| Installing a microprocessor-retention assembly . . . . . | 890 |

**Appendix A. Getting help and technical assistance . . . . .893**

|  |     |
|--|-----|
| Before you call . . . . .                                      | 893 |
| Using the documentation . . . . .                              | 894 |
| Getting help and information from the World Wide Web . . . . . | 894 |
| How to send DSA data . . . . .                                 | 894 |
| Creating a personalized support web page . . . . .             | 894 |
| Software service and support . . . . .                         | 894 |
| Hardware service and support . . . . .                         | 895 |
| Taiwan product service . . . . .                               | 895 |

**Appendix B. Notices . . . . .897**

|  |     |
|--|-----|
| Trademarks . . . . .   | 898 |
| Important notes . . . . .  | 898 |
| Recycling information . . . . .  | 898 |
| Particulate contamination . . . . .  | 899 |
| Telecommunication regulatory statement . . . . .                           | 899 |
| Electronic emission notices . . . . .                                      | 900 |
| Federal Communications Commission (FCC) statement . . . . .                | 900 |
| Industry Canada Class A emission compliance statement . . . . .            | 900 |
| Avis de conformité à la réglementation d'Industrie Canada. . . . .         | 900 |
| Australia and New Zealand Class A statement . . . . .                      | 900 |
| European Union EMC Directive conformance statement . . . . .               | 900 |
| Germany Class A statement . . . . .  | 901 |
| Japanese electromagnetic compatibility statements . . . . .                | 902 |
| Korea Communications Commission (KCC) statement . . . . .                  | 902 |
| Russia Electromagnetic Interference (EMI) Class A statement . . . . .      | 902 |
| People's Republic of China Class A electronic emission statement . . . . . | 902 |
| Taiwan Class A compliance statement . . . . .                              | 902 |
| Taiwan BSMI RoHS declaration . . . . .                                     | 903 |

**Index . . . . .905**



---

## Safety

Before installing this product, read the Safety Information.

قبل تركيب هذا المنتج، يجب قراءة الملاحظات الأمنية

Antes de instalar este produto, leia as Informações de Segurança.

**在安装本产品之前，请仔细阅读 Safety Information (安全信息)。**

安裝本產品之前，請先閱讀「安全資訊」。

Prije instalacije ovog produkta obavezno pročitajte Sigurnosne Upute.

Před instalací tohoto produktu si přečtěte příručku bezpečnostních instrukcí.

Læs sikkerhedsforskrifterne, før du installerer dette produkt.

Lees voordat u dit product installeert eerst de veiligheidsvoorschriften.

Ennen kuin asennat tämän tuotteen, lue turvaohjeet kohdasta Safety Information.

Avant d'installer ce produit, lisez les consignes de sécurité.

Vor der Installation dieses Produkts die Sicherheitshinweise lesen.

Πριν εγκαταστήσετε το προϊόν αυτό, διαβάστε τις πληροφορίες ασφάλειας (safety information).

לפני שתתקינו מוצר זה, קראו את הוראות הבטיחות.

A termék telepítése előtt olvassa el a Biztonsági előírásokat!

Prima di installare questo prodotto, leggere le Informazioni sulla Sicurezza.

製品の設置の前に、安全情報をお読みください。

본 제품을 설치하기 전에 안전 정보를 읽으십시오.

Пред да се инсталира овој продукт, прочитајте информацијата за безбедност.

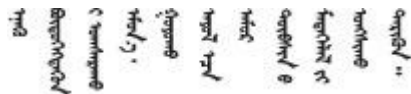

Les sikkerhetsinformasjonen (Safety Information) før du installerer dette produktet.

Przed zainstalowaniem tego produktu, należy zapoznać się z książką "Informacje dotyczące bezpieczeństwa" (Safety Information).

Antes de instalar este producto, leia as Informações sobre Segurança.

Перед установкой продукта прочтите инструкции по технике безопасности.

Pred inštaláciou tohto zariadenia si pečítajte Bezpečnostné predpisy.

Pred namestitvijo tega proizvoda preberite Varnostne informacije.

Antes de instalar este producto, lea la información de seguridad.

Läs säkerhetsinformationen innan du installerar den här produkten.

ཐོན་ཇུས་འདི་བདེ་སྤྱོད་མ་བྱས་གོང་། སྐྱོར་གྱི་ཡིད་གཟབ་  
བྱ་འདྲ་མིན་ཡིད་པའི་འོད་ཟེར་བལྟ་དགོས།

Bu ürünü kurmadan önce güvenlik bilgilerini okuyun.

مەزكۇر مەھسۇلاتنى ئورنىتىشتىن بۇرۇن بىخەتەرلىك ئۇچۇرلىرىنى ئوقۇپ چىقىڭ.

Youq mwngz yungh canjbinj neix gaxgonq, itdingh aeu doeg aen  
canjbinj soengq cungj vahgangj ancien siusik.

---

## Safety statements

These statements provide the caution and danger information that is used in this documentation.

**Important:** Each caution and danger statement in this documentation is labeled with a number. This number is used to cross reference an English-language caution or danger statement with translated versions of the caution or danger statement in the *Safety Information* document.

For example, if a caution statement is labeled Statement 1, translations for that caution statement are in the *Safety Information* document under Statement 1.

Be sure to read all caution and danger statements in this documentation before you perform the procedures. Read any additional safety information that comes with your system or optional device before you install the device.

### Statement 1





**DANGER**

Electrical current from power, telephone, and communication cables is hazardous.

To avoid a shock hazard:

- Do not connect or disconnect any cables or perform installation, maintenance, or reconfiguration of this product during an electrical storm.
- Connect all power cords to a properly wired and grounded electrical outlet.
- Connect to properly wired outlets any equipment that will be attached to this product.
- When possible, use one hand only to connect or disconnect signal cables.
- Never turn on any equipment when there is evidence of fire, water, or structural damage.
- Disconnect the attached power cords, telecommunications systems, networks, and modems before you open the device covers, unless instructed otherwise in the installation and configuration procedures.
- Connect and disconnect cables as described in the following table when installing, moving, or opening covers on this product or attached devices.

**To Connect:**

1. Turn everything OFF.
2. First, attach all cables to devices.
3. Attach signal cables to connectors.
4. Attach power cords to outlet.
5. Turn device ON.

**To Disconnect:**

1. Turn everything OFF.
2. First, remove power cords from outlet.
3. Remove signal cables from connectors.
4. Remove all cables from devices.

## Statement 2



### CAUTION:

When replacing the lithium battery, use only Part Number 33F8354 or an equivalent type battery recommended by the manufacturer. If your system has a module containing a lithium battery, replace it only with the same module type made by the same manufacturer. The battery contains lithium and can explode if not properly used, handled, or disposed of. *Do not:*

- Throw or immerse into water
- Heat to more than 100°C (212°F)
- Repair or disassemble

Dispose of the battery as required by local ordinances or regulations.

## Statement 12



### CAUTION:

The following label indicates a hot surface nearby.



Statement 21



**CAUTION:**

**Hazardous energy is present when the blade is connected to the power source. Always replace the blade cover before installing the blade.**

**UL regulatory information**

This device is for use only with Listed chassis.

---

## Chapter 1. Introduction

The Lenovo Flex System x440 Compute Node Types 7167 and 2590 is a high-availability, scalable compute node that is optimized to support the next-generation microprocessor technology and is ideally suited for medium and large businesses.

The x440 Compute Node Types 7167 and 2590 is supported in the Flex System Enterprise Chassis only.

This documentation provides the following information about setting up and troubleshooting the compute node:

- Starting and configuring the compute node
- Installing the operating system
- Diagnosing problems
- Installing, removing, and replacing components

Packaged with the compute node are software CDs that help you configure hardware, install device drivers, and install the operating system.

To download the latest firmware and device drivers, go to <http://www.ibm.com/support/fixcentral> and select **PureSystems, PureFlex System, Compute Node** and **x440 Compute Node**.

The compute node comes with a limited warranty. For information about the terms of the warranty and getting service and assistance, see the *Lenovo Warranty Information* document for your compute node. This document is available on the Lenovo *Documentation CD*.

You can obtain up-to-date information about the compute node at <http://www.ibm.com/systems>.

The compute node might have features that are not described in the documentation that comes with the compute node. The documentation might be updated occasionally to include information about those features. Technical updates might also be available to provide additional information that is not included in the compute node documentation. To obtain the most up-to-date documentation for this product, go to <http://pic.dhe.ibm.com/infocenter/flexsys/information/index.jsp>.

You can subscribe to information updates that are specific to your compute node at <http://www.ibm.com/support/mynotifications>.

The model number and serial number are on the ID label on the bezel on the front of the compute node, and on a label on the bottom of the compute node that is visible when the compute node is not in the Flex System chassis. If the compute node comes with an RFID tag, the RFID tag covers the ID label on the bezel on the front of the compute node but you can open the RFID tag to see the ID label behind it.

**Note:** The illustrations in this document might differ slightly from your hardware.

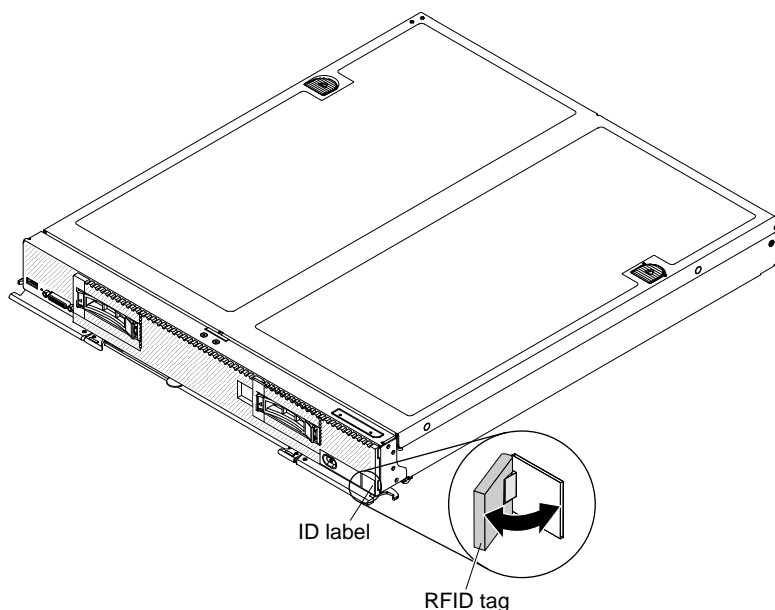

---

## Related documentation

Use this information to identify and locate related compute node documentation.

This *Installation and Service Guide* contains general information about the compute node, including how to install supported optional devices and how to configure the compute node. It also contains information to help you solve problems yourself and instructions for removing and installing components, and it contains information for service technicians. Documents that are in Portable Document Format (PDF) are on the documentation CD that comes with your product. The following documentation is also available.

- *Safety Information*

This document is in PDF. It contains translated caution and danger statements. Each caution and danger statement that appears in the documentation has a number that you can use to locate the corresponding statement in your language in the *Safety Information* document.

- *Lenovo Warranty Information*

This printed document contains the warranty terms and a pointer to the Lenovo Statement of Limited Warranty.

- *Environmental Notices and User Guide*

This document is in PDF. It contains translated environmental notices.

- *License Agreement for Machine Code*

This document is in PDF. It provides translated versions of the License Agreement for Machine code for your compute node.

- *Licenses and Attributions Document*

This document is in PDF. It provides information about the open-source notices.

In addition to the documentation in this library, be sure to review the *Installation and Service Guide* for your Flex System chassis for information to help you prepare for system installation and configuration.

To check for updated documentation, go to <http://www.lenovo.com/support>.

You can also find documentation that is related to Flex System products at <http://pic.dhe.ibm.com/infocenter/flexsys/information/index.jsp>.

---

## Brocade documentation

Use this information to identify and locate related Brocade documentation.

The following section introduces Brocade documents that you might find useful for the installation and administration.

- **EN4023 User Guide**

- *Network OS Layer 2 Switching Configuration Guide* - <http://www.brocade.com/content/html/en/configuration-guide/nos-601a-l2guide/>
- *Network OS Command Reference Guide* - <http://www.brocade.com/content/html/en/command-reference-guide/nos-601a-commandref/index.html>
- *Network OS Message Reference* - <http://www.brocade.com/content/html/en/message-reference-guides/nos-601a-messageref/wwhelp/wwhimpl/js/html/wwhelp.htm>

- **FC5022 User Guide**

- *Fabric OS Administrator's Guide* - <http://www.brocade.com/content/html/en/administration-guide/fos-740-adminguide/>
- *Fabric OS Command Reference* - <http://www.brocade.com/content/html/en/command-reference-guide/fos-741-commandref/wwhelp/wwhimpl/js/html/wwhelp.htm>
- *Fabric OS Message Reference* - [http://www.brocade.com/content/html/en/message-reference-guides/FOS\\_740\\_MESSAGES/wwhelp/wwhimpl/js/html/wwhelp.htm#href=Title.1.2.html](http://www.brocade.com/content/html/en/message-reference-guides/FOS_740_MESSAGES/wwhelp/wwhimpl/js/html/wwhelp.htm#href=Title.1.2.html)
- *Access Gateway Administrator's Guide* - <http://www.brocade.com/content/html/en/administration-guide/fos-740-accessgateway/index.html>

---

## The Lenovo Documentation CD

The documentation CD contains documentation for the compute node in Portable Document Format (PDF). It includes a documentation browser to help you find information quickly.

You can run the documentation CD on any computer that meets the hardware and software requirements.

### Hardware and software requirements

Use this information to determine the minimum hardware and software requirements.

The Lenovo *Documentation* CD requires the following minimum hardware and software:

- Microsoft Windows
- 100 MHz microprocessor
- 32 MB of RAM
- Adobe Acrobat Reader 3.0 (or later) or xpdf, which comes with Linux operating systems

### Using the Documentation Browser

Use this information to start the Documentation Browser.

Use the Documentation Browser to browse the contents of the CD, read brief descriptions of the documents, and view documents, using Adobe Acrobat Reader or xpdf. The Documentation Browser automatically detects the regional settings in use in your system and displays the documents in the language for that region (if available). If a document is not available in the language for that region, the English-language version is displayed.

Use one of the following procedures to start the Documentation Browser:

- If Autostart is enabled, insert the CD into the CD or DVD drive. The Documentation Browser starts automatically.
- If Autostart is disabled or is not enabled for all users, use one of the following procedures:
  - If you are using a Windows operating system, insert the CD into the CD or DVD drive and click **Start** → **Run**. In the **Open** field, type  
`e:\win32.bat`  
 where *e* is the drive letter of the CD or DVD drive, and click **OK**.
  - If you are using Red Hat Linux, insert the CD into the CD or DVD drive; then, run the following command from the `/mnt/cdrom` directory:  
`sh runlinux.sh`

Select the compute node from the **Product** menu. The **Available Topics** list displays all the documents for the compute node. Some documents might be in folders. A plus sign (+) indicates each folder or document that has additional documents under it. Click the plus sign to display the additional documents.

When you select a document, a description of the document is displayed under **Topic Description**. To select more than one document, press and hold the Ctrl key while you select the documents. Click **View Book** to view the selected document or documents in Acrobat Reader or xpdf. If you selected more than one document, all the selected documents are opened in Acrobat Reader or xpdf.

To search all the documents, type a word or word string in the **Search** field and click **Search**. The documents in which the word or word string appears are listed in order of the most occurrences. Click a document to view it. Press Ctrl+F to use the Acrobat search function, or press Alt+F to use the xpdf search function within the document.

Click **Help** for detailed information about using the Documentation Browser.

---

## Notices and statements in this document

Use this information to understand the most common documentation notices and statements and how they are used.

The caution and danger statements in this document are also in the multilingual *Safety Information* document, which is on the documentation CD. Each statement is numbered for reference to the corresponding statement in the *Safety Information* document.

The following notices and statements are used in this document:

- **Note:** These notices provide important tips, guidance, or advice.
- **Important:** These notices provide information or advice that might help you avoid inconvenient or problem situations.
- **Attention:** These notices indicate possible damage to programs, devices, or data. An attention notice is placed just before the instruction or situation in which damage might occur.
- **Caution:** These statements indicate situations that can be potentially hazardous to you. A caution statement is placed just before the description of a potentially hazardous procedure step or situation.
- **Danger:** These statements indicate situations that can be potentially lethal or hazardous to you. A danger statement is placed just before the description of a potentially lethal or hazardous procedure step or situation.



---

## Features and specifications

Use this information to view specific information about the compute node, such as compute node hardware features and the dimensions of the compute node.

### Notes:

1. Power, cooling, and chassis systems management are provided by the Flex System chassis.
2. The operating system in the compute node must provide USB support for the compute node to recognize and use USB media drives and devices.

The following table is a summary of the features and specifications of the x440 Compute Node Types 7167 and 2590.

Table 1. Features and specifications

| Features and specifications   |   |  |
|---|---|--|
| <p><b>Microprocessor:</b> One, two or four multi-core IntelXeon microprocessors.</p> <p><b>Notes:</b></p> <ol style="list-style-type: none"> <li>1. Use the Setup utility to determine the type and speed of the microprocessors in the compute node.</li> <li>2. Configurations with three installed microprocessors are not supported.</li> </ol> <p><b>Note:</b></p> <p><b>Integrated functions:</b></p> <ul style="list-style-type: none"> <li>• Renesas SH7757 (IMM2) baseboard management controller (BMC) with integrated VGA controller</li> <li>• (Models with LAN-on-motherboard (LOM) only) Two LOM Periscope connectors</li> <li>• (Models with LOM only) Two Emulex BE3 dual-port 10 Gigabit Ethernet controller</li> <li>• Support for up to two internal USB ports</li> <li>• One external USB port</li> <li>• One LSI 2004 SAS controller with support for RAID level-0 or RAID level-1</li> <li>• Light path diagnostics</li> <li>• Automatic server restart (ASR)</li> <li>• One Resesas H8S2117 Real Time Management Module (RTMM)</li> <li>• One Xilinx Spartan 6 Field Programmable Gate Array (FPGA)</li> <li>• Four Fabric Mezzanine connectors</li> <li>• Concurrent keyboard/video/mouse (cKVM)</li> <li>• Serial over LAN (SOL)</li> <li>• Wake on LAN (WOL)</li> </ul> | <p><b>Upgradeable firmware:</b> All firmware is field upgradeable.</p> <p><b>Security:</b> Fully compliant with NIST 800-131A. The security cryptography mode set by the managing device (CMM, Lenovo XClarity Administrator or Flex System Manager management node) determines the security mode in which the compute node operates.</p> <p><b>Memory:</b></p> <ul style="list-style-type: none"> <li>• 48 dual inline memory module (DIMM) connectors</li> <li>• Type: Low-profile (LP) double-data rate (DDR3) DRAM</li> <li>• Supports 4 GB, 8 GB, 16 GB and 32 GB DIMMs with up to 1536 GB of total memory on the system board</li> <li>• Support for RDIMMs, LRDIMMs, and UDIMMS (combining is not supported)</li> </ul> <p><b>Predictive Failure Analysis (PFA) alerts:</b></p> <ul style="list-style-type: none"> <li>• Microprocessors</li> <li>• Memory</li> <li>• Hard disk drives</li> </ul> <p><b>Drives:</b> Supports up to two hot-swap, small form factor (SFF) Serial Attached SCSI (SAS) or Serial ATA (SATA) hard disk drives.</p> <p><b>Size:</b></p> <ul style="list-style-type: none"> <li>• Height: 55.5 mm (2.19 in)</li> <li>• Depth: 492.7 mm (19.4 in)</li> <li>• Width: 435.3 mm (17.14 in)</li> <li>• Maximum weight: 12.25 kg (27 lbs)</li> </ul> | <p><b>Environment:</b> The x440 Compute Node Types 7167 and 2590 complies with ASHRAE class A3 specifications.</p> <ul style="list-style-type: none"> <li>• Power on<sup>1</sup>: <ul style="list-style-type: none"> <li>– Temperature: 5°C - 40°C (41°F - 104°F) up to 950m (3,117ft)<sup>3</sup></li> <li>– Humidity, non-condensing: -12° C dew point (10.4°F) and 8% - 85% relative humidity<sup>5,6</sup></li> <li>– Maximum dew point: 24°C (75°F)</li> <li>– Maximum altitude: 3048 m (10,000 ft)</li> <li>– Maximum rate of temperature change: 5°C/hr (41°F/hr)<sup>4</sup></li> </ul> </li> <li>• Power off<sup>2</sup>: <ul style="list-style-type: none"> <li>– Temperature: 5°C to 45°C (41°F - 113°F)</li> <li>– Relative humidity: 8% - 85%</li> <li>– Maximum dew point: 27°C (80.6° F)</li> </ul> </li> <li>• Storage (non-operating): <ul style="list-style-type: none"> <li>– Temperature: 1°C to 60°C (33.8° F - 140°F)</li> <li>– Altitude: 3050 m (10,006 ft)</li> <li>– Relative humidity: 5% - 80%</li> <li>– Maximum dew point: 29°C (84.2° F)</li> </ul> </li> <li>• Shipment (non-operating)<sup>7</sup>: <ul style="list-style-type: none"> <li>– Temperature: -40°C to 60°C (-40°F - 140°F)</li> <li>– Altitude: 10,700 m (35,105 ft)</li> <li>– Relative humidity: 5% - 100%</li> <li>– Maximum dew point: 29°C (84.2° F)<sup>8</sup></li> </ul> </li> <li>• Particulate contamination</li> </ul> <p><b>Attention:</b> Airborne particulates and reactive gases acting alone or in combination with other environmental factors such as humidity or temperature might pose a risk to the compute node. For information about the limits for particulates and gases, see “Particulate contamination” on page 899.</p> |
| <p>1. Compute Node powered on.</p>  |   |  |

Table 1. Features and specifications (continued)

| Features and specifications   |
|---|
| 2. Compute Node is removed from original shipping container and is installed but not in use, for example, during repair, maintenance, or upgrade.   |
| 3. A3 - Derate maximum allowable temperature 1°C/175 m above 950 m. At maximum altitude of 3,050m (10kft) maximum air temperature is 28°C (82°F)  |
| 4. 5°C/hr for data centers employing tape drives and 20°C/hr for data centers employing disk drives.  |
| 5. The minimum humidity level for class A3 is the higher (more moisture) of the -12°C dew point and the 8% relative humidity. These intersect at approximately 25°C. Below this intersection (~25°C), the dew point (-12°C) represents the minimum moisture level; above the intersection, relative humidity (8%) is the minimum.   |
| 6. Moisture levels lower than 0.5°C DP, but not lower -10°C DP or 8% relative humidity, can be accepted if appropriate control measures are implemented to limit the generation of static electricity on personnel and equipment in the data center. All personnel and mobile furnishings and equipment must be connected to ground via an appropriate static control system. The following items are considered the minimum requirements: <ol style="list-style-type: none"> <li>a. Conductive materials (conductive flooring, conductive footwear on all personnel who go into the datacenter; all mobile furnishings and equipment will be made of conductive or static dissipative materials).</li> <li>b. During maintenance on any hardware, a properly functioning wrist strap must be used by any personnel who contacts IT equipment.</li> </ol> |
| 7. The equipment acclimation period is 1 hour per 20°C of temperature change from the shipping environment to the operating environment.  |
| 8. Condensation is acceptable, but not rain.  |
| 9. The fully configured chassis weight is based on all nodes and I/O modules being at their maximum design limit.   |

## What your compute node offers

Your compute node offers features such as the integrated management module 2, hard disk drive support, systems-management support, microprocessor technology, integrated network support, I/O expansion, large system-memory capacity, light path diagnostics LEDs, PCI Express, and power throttling.

- **Features on Demand**

If a Features on Demand feature is integrated in the compute node or in an optional device that is installed in the compute node, you can purchase an activation key to activate the feature. For information about Features on Demand, see <https://fod.lenovo.com/lkms>.

- **Dynamic System Analysis (DSA)**

Dynamic System Analysis (DSA) collects and analyzes system information to aid in diagnosing compute node problems. DSA collects the following information about the compute node:

- Drive health information
- Event logs for ServeRAID controllers and service processors
- Hardware inventory, including PCI and USB information
- Installed applications and hot fixes
- Kernel modules
- Light path diagnostics status
- Network interfaces and settings
- Performance data and details about processes that are running
- RAID and controller configuration
- Integrated management module 2 status and configuration
- System configuration

- Vital product data and firmware information

DSA creates a DSA log, which is a chronologically ordered merge of the system-event log (as the IPMI event log), the IMM event log (as the ASM event log), and the operating-system event logs. You can send the DSA log as a file to a support representative or view the information as a text file or HTML file.

For more information, see “Lenovo Dynamic System Analysis Preboot diagnostic program ” on page 65.

- **Flexible network support**

The compute node provides flexible network capabilities:

- **Models without embedded virtual fabric:** The compute node has connectors on the system board for optional expansion adapters for adding network communication capabilities to the compute node. You can install up to two I/O expansion adapters for network support. This provides the flexibility to install expansion adapters that support a variety of network communication technologies.

- **Hard disk drive support**

The compute node supports up to two hot-swap hard disk drives. You can implement RAID 0 or RAID 1 for the drives.

- **LenovoServerGuide Setup and InstallationCD**

The *ServerGuide Setup and Installation* CD, which you can download from the web, provides programs to help you set up the compute node and install a Windows operating system. The ServerGuide program detects installed optional hardware devices and provides the correct configuration programs and device drivers. For more information, see “Using the ServerGuide Setup and Installation CD” on page 40.

- **Integrated management module II (IMM2)**

The integrated management module II (IMM2) combines systems-management functions, video controller, the remote presence, and blue-screen capture features in a single chip. The IMM2 provides advanced systems-management control, monitoring, and alerting function. If an environmental condition exceeds a threshold or if a system component fails, the IMM2 lights LEDs to help you diagnose the problem, records the error in the IMM event log, and alerts you to the problem.

Optionally, the IMM2 also provides a virtual presence capability for remote systems management capabilities. The IMM2 provides remote systems management through industry-standard interfaces:

- Common Information Model (CIM)
- Intelligent Platform Management Interface (IPMI) version 2.0
- Simple Network Management Protocol (SNMP) version 3.0
- Web browser

For more information, see Chapter 4 “Accessing the IMM2” on page 43.

- **Large system-memory capacity**

The compute node supports up to 1536 GB of system memory. The memory controller provides support for up to 48 industry-standard registered ECC DDR3 on low-profile (LP) DIMMs on the system board. For the most current list of supported DIMMs, see <http://www.lenovo.com/serverproven/>.

- **Light path diagnostics**

Light path diagnostics provides light-emitting diodes (LEDs) to help you diagnose problems. For more information, see “Light path diagnostics” on page 57.

- **Microprocessor technology**

The compute node supports up to four multi-core IntelXeon microprocessors. For more information about supported microprocessors and their part numbers, see Chapter 5 “Parts listing, Types 7167 and 2590” on page 51.

**Note:** The optional microprocessors are limited by the capacity and capability of the compute node. Any microprocessor that you install must have the same specifications as the microprocessor that came with the compute node.

- **PCI Express**

PCI Express is a serial interface that is used for chip-to-chip interconnect and expansion adapter interconnect. You can add optional I/O and storage devices.

- **Power throttling**

By enforcing a power policy known as power-domain oversubscription, the Flex System chassis can share the power load between two or more power supply modules to ensure sufficient power for each device in the Flex System chassis. This policy is enforced when the initial power is applied to the Flex System chassis or when a compute node is inserted into the Flex System chassis.

The following settings for this policy are available:

- Basic power management
- Power module redundancy
- Power module redundancy with compute node throttling allowed

You can configure and monitor the power environment by using the Chassis Management Module. For more information, see the Flex System Chassis Management Module: Command-Line Interface Reference Guide at [http://pic.dhe.ibm.com/infocenter/flexsys/information/topic/com.lenovo.acc.cmm.doc/dw1kt\\_cmm\\_cli\\_book.pdf](http://pic.dhe.ibm.com/infocenter/flexsys/information/topic/com.lenovo.acc.cmm.doc/dw1kt_cmm_cli_book.pdf).

- **Systems-management support**

The compute node IMM2 provides a Web interface for remote systems-management support. You can use the interface to view system status, and control server management functions and IMM management settings.

The IMM2 communicates with the Flex System Chassis Management Module (CMM) and the Lenovo XClarity Administrator or Flex System Manager management software (if available).

- CMM is a hot-swap module that provides system-management functions for all components in an Flex System chassis. It controls a serial port for remote connection and a 1 Gbps Ethernet remote-management connection. For more information, see the the Flex System Chassis Management Module: Command-Line Interface Reference Guide at [http://pic.dhe.ibm.com/infocenter/flexsys/information/topic/com.lenovo.acc.cmm.doc/dw1kt\\_cmm\\_cli\\_book.pdf](http://pic.dhe.ibm.com/infocenter/flexsys/information/topic/com.lenovo.acc.cmm.doc/dw1kt_cmm_cli_book.pdf).
- The Lenovo XClarity Administrator is a virtual appliance that you can use to manage Flex System chassis in a secure environment. The Lenovo XClarity Administrator provides a central interface to perform the following functions for all managed endpoints:
  - User management
  - Hardware monitoring and management
  - Configuration management
  - Operating system deployment
  - Firmware management

For more information, see <https://support.lenovo.com/us/en/documents/LNVO-XCLARIT>.

- Flex System Manager management software is a platform-management foundation that streamlines the way you manage physical and virtual systems in a heterogeneous environment. By using industry standards, Flex System Manager management software supports multiple operating systems and virtualization technologies. For more information, see .

- **Lenovo XClarity Administrator**

Lenovo XClarity Administrator is a centralized resource-management solution that enables administrators to deploy infrastructure faster and with less effort. The solution seamlessly integrates into System x, ThinkServer, and NeXtScale servers, as well as the Flex System converged infrastructure platform.

Lenovo XClarity Administrator provides:

- Automated discovery

- Agent-free hardware management
- Monitoring
- Firmware updates and compliance
- Pattern-based configuration management
- Deployment of operating systems and hypervisors

Administrators are able to find the right information and accomplish critical tasks faster through an uncluttered, dashboard-driven graphical user interface (GUI). Centralizing and automating foundational infrastructure deployment and lifecycle management tasks across large pools of systems frees up administrator time, and makes resources available to end-users faster.

Lenovo XClarity is easily extended into the leading virtualization management platforms from Microsoft and VMware using software plug-ins, called Lenovo XClarity Integrators. The solution improves workload uptime and service-level assurance by dynamically relocating workloads from affected hosts in the cluster during rolling server reboots or firmware updates, or during predicted hardware failures.

For more information about Lenovo XClarity Administrator, see the <http://shop.lenovo.com/us/en/systems/software/systems-management/xclarity/> and the [http://pic.dhe.ibm.com/infocenter/flexsys/information/topic/com.lenovo.lxca.doc/aug\\_product\\_page.html](http://pic.dhe.ibm.com/infocenter/flexsys/information/topic/com.lenovo.lxca.doc/aug_product_page.html).

- **Installing Lenovo XClarity Administrator**

- **Installing Lenovo XClarity Administrator for the first time**

The initial setup of Lenovo XClarity Administrator involves preparing the network, installing and configuring the Lenovo XClarity Administrator virtual appliance, managing systems, and optionally setting up automatic problem notification.

There are a number of different ways to connect manageable systems to the network and to set up the Lenovo XClarity Administrator to manage those systems based on the network topology that is implemented in your environment. For guidance for installing the Lenovo XClarity Administrator in VMware ESXi-based and Hyper-V environments, see <http://pic.dhe.ibm.com/infocenter/flexsys/information/index.jsp?topic=%2Fcom.lenovo.lxca.doc%2Fsetup.html>.

- **Free 90-day trial**

Lenovo XClarity Administrator offers a free, 90-day trial license that enables you to use all available features (including operating-system deployment, firmware maintenance, and configuration management) for a limited time.

After 90 days, you can continue to use Lenovo XClarity Administrator to manage and monitor your hardware for free; however, you must purchase a full-function-enablement license to continue using Lenovo XClarity Administrator to configure your hardware using Configuration Patterns and to deploy operating systems. You can purchase Lenovo XClarity Administrator licenses from your Lenovo seller or business partner.

For information about installing the license, see [http://pic.dhe.ibm.com/infocenter/flexsys/information/index.jsp?topic=%2Fcom.lenovo.lxca.doc%2Fupdate\\_lxcasw.html](http://pic.dhe.ibm.com/infocenter/flexsys/information/index.jsp?topic=%2Fcom.lenovo.lxca.doc%2Fupdate_lxcasw.html).

- **Updating Lenovo XClarity Administrator**

You can download or import Lenovo XClarity Administrator updates and install the updates from the Lenovo XClarity Administrator web interface. For information about updating a Lenovo XClarity Administrator, see [http://pic.dhe.ibm.com/infocenter/flexsys/information/index.jsp?topic=%2Fcom.lenovo.lxca.doc%2Fupdate\\_lxcasw.html](http://pic.dhe.ibm.com/infocenter/flexsys/information/index.jsp?topic=%2Fcom.lenovo.lxca.doc%2Fupdate_lxcasw.html). Ensure that you carefully read the Installation and Setup Instructions in the `Invgy_sw_lxca_***_anyos_noarch.txt` file that is provided in the update package .zip file.

---

## Lenovo XClarity Administrator

Lenovo XClarity Administrator is a centralized, resource-management solution that simplifies infrastructure management, speeds responses, and enhances the availability of Lenovo® server systems and solutions. It runs as a virtual appliance that automates discovery, inventory, tracking, monitoring, and provisioning for Lenovo servers, Flex System servers, and RackSwitch switches in a secure environment.

Lenovo XClarity Administrator provides a central interface to perform the following functions for all managed endpoints.

- **Hardware management**

Lenovo XClarity Administrator provides agent-free hardware management. It can automatically discover manageable endpoints, including Flex System chassis and components, System x, NeXtScale, and ThinkServer servers, and RackSwitch switches. Inventory of the discovered endpoints is also gathered, so an at-a-glance view of the managed hardware inventory and status is possible.

- **Hardware monitoring**

Lenovo XClarity Administrator provides a centralized view of all events and alerts that are generated from the managed endpoints. When a CMM or IMM detects an issue, an alert or event is passed to the Lenovo XClarity Administrator and is displayed in the events or alerts log. A summary of all alerts and events is visible from the Dashboard and the Status bar. Events and alerts for a specific endpoint are available from the Alerts and Events detail page for that endpoint.

- **Operating-system deployment**

You can use Lenovo XClarity Administrator to manage the repository of operating-system images and deploy operating-system images to managed servers.

- **Configuration management**

You can quickly provision and pre-provision all of your servers using a consistent configuration. Configuration settings (such as local storage, I/O adapters, boot settings, firmware, ports, and IMM and UEFI settings) are saved as a server pattern that can be applied to one or more managed servers. When the server patterns are updated, the changes are automatically deployed to the applied servers.

- **Firmware compliance and updates**

Firmware management is simplified by assigning firmware-compliance policies to managed endpoints. When you create and assign a compliance policy to managed endpoints, Lenovo XClarity Administrator monitors changes to the inventory for those endpoints and flags any endpoints that are out of compliance.

- **User management**

Lenovo XClarity Administrator provides a centralized authentication server to create and manage user accounts and to manage and authenticate user credentials. The authentication server is created automatically when you start the management server for the first time. The user accounts that you create for Lenovo XClarity Administrator are also used to log in to managed chassis and servers.

- **Security**

If your environment must comply with either NIST SP 800-131A or FIPS 140-2 standards, Lenovo XClarity Administrator can help you achieve a fully compliant environment. It supports self-signed SSL certificates (which are issued by an internal certificate authority) and external SSL certificates (which are issued by a private or commercial CA). Firewalls on chassis and servers can be configured to accept incoming requests from only Lenovo XClarity Administrator.

- **Service and support**

Lenovo XClarity Administrator can be set up to collect and send diagnostic files automatically to your preferred service provider when certain serviceable events occur in Lenovo XClarity Administrator and the managed endpoints. You can choose to send diagnostic files to Lenovo Support using call home or to

another service provider using SFTP. You can also manually collect diagnostic files, open a problem record, and send diagnostic files to the Lenovo Support Center.

- **Task automation using scripts**

Lenovo XClarity Administrator can be integrated into external, higher-level management and automation platforms through open REST application programming interfaces (APIs). Using the REST APIs, Lenovo XClarity Administrator can easily integrate with your existing management infrastructure. You can also run Lenovo XClarity *cmdlets* in a Microsoft PowerShell session to automate certain management functions. The cmdlets use Lenovo XClarity Administrator REST APIs and can automate functions

- **Integration with other management software**

Lenovo XClarity Administrator is available stand-alone or as a bundled offering that is known as Lenovo XClarity Pro. Lenovo XClarity Pro is composed of the base Administrator product plus two Lenovo XClarity Integrator modules that provide integration into Microsoft Systems Center or VMware vCenter. Together, these tools provide discovery, monitoring, configuration, and management functions to reduce the cost and complexity of routine system administration for System x, NeXtScale, and Flex System endpoints.

More information about Lenovo XClarity Administrator is available at <http://shop.lenovo.com/us/en/systems/software/systems-management/xclarity/>.

---

## Reliability, availability, and serviceability features

Three of the most important features in compute node design are reliability, availability, and serviceability (RAS). These RAS features help to ensure the integrity of the data that is stored in the compute node, the availability of the compute node when you need it, and the ease with which you can diagnose and correct problems.

The compute node has the following RAS features:

- 24-hour support center
- Advanced Configuration and Power Interface (ACPI)
- Automatic server restart (ASR)
- Built-in diagnostics using DSA Preboot
- Built in monitoring for temperature, voltage, and hard disk drives
- Customer support center 24 hours per day, 7 days a week<sup>1</sup>
- Customer upgrade of flash ROM-resident code and diagnostics
- Customer-upgradeable Unified Extensible Firmware Interface (UEFI) code and diagnostics
- ECC protected DDR3 DIMMs
- ECC protection on the L2 cache
- Error codes and messages
- Integrated management module II (IMM2) that communicates with the Chassis Management Module to enable remote systems management
- Light path diagnostics
- Memory mirroring mode support
- Microprocessor built-in self-test (BIST) during power-on self-test (POST)
- Microprocessor Intel QuickPath Interconnect bus and CRC checking
- Microprocessor serial number access
- PCI bus even parity checking
- POST
- Power policy
- Processor presence detection
- Rank-sparing mode support
- ROM-resident diagnostics

---

1. Service availability varies by country. Response time varies depending on the number and nature of incoming calls.



- System-error logging
- Vital product data (VPD) on memory
- Wake on LAN capability
- Wake on PCI (PCIe Expansion Node) capability

---

## Major components of the compute node

Use this information to locate the major components on the compute node. The major components of the compute node include field replaceable units (FRUs), customer replaceable units (CRUs), and optional devices.

The following illustration shows the major components of the compute node.

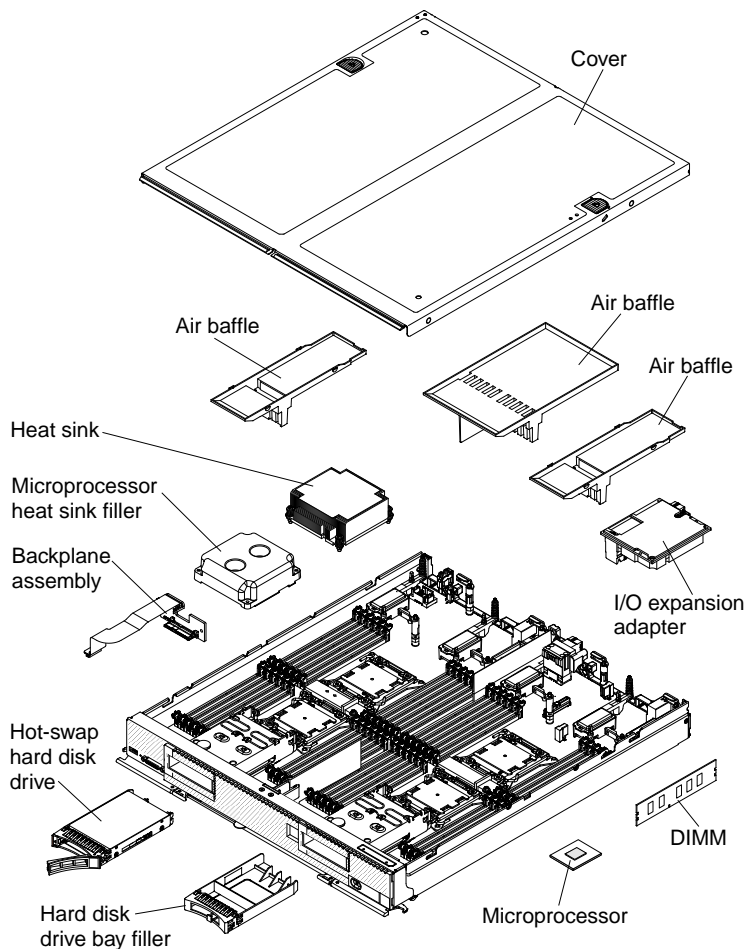

---

## Power, controls, and indicators

Use this information to view power features, turn on and turn off the compute node, and view the functions of the controls and indicators.

### Compute node controls, connectors, and LEDs

Use this information for details about the controls, connectors, and LEDs.

The following illustration identifies the buttons, connectors, and LEDs on the control panel.

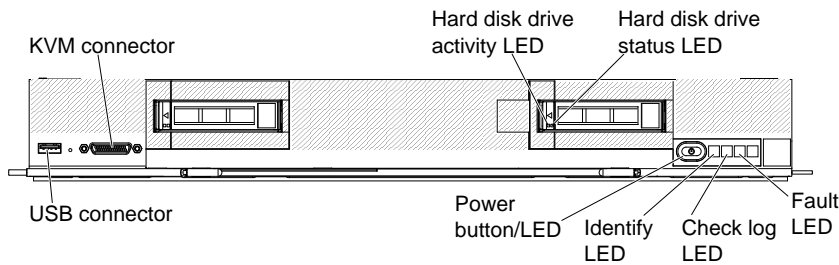

### Fault LED

When this yellow LED is lit, it indicates that a system error has occurred in the compute node. In addition, the fault LED on the chassis system LED panel is lit. You can check the CMM event log to determine the source of the condition. For more information, see “Viewing event logs without restarting the compute node” on page 63. See also “Light path diagnostics LEDs” on page 59 for more information about the LEDs on the compute node.

The fault LED turns off only after the error is corrected.

**Note:** When the fault LED turns off, you should also clear the IMM event log. Use the Setup utility to clear the IMM event log.

### Check log LED

When this yellow LED is lit, it indicates that a condition that causes an event to be logged in the event log has occurred. To view the IMM2 event log see “IMM event log” on page 63

The check log LED can be turned off through the CMM **led** command, the CMM web interface, the Lenovo XClarity Administrator (if available), or the Flex System Manager management software (if available).

- For more information about the CMM **led** command, see the .
- From the CMM web interface, select **Compute Nodes** from the **Chassis Management** menu. All fields and options are described in the CMM web interface online help. For more information, see [http://pic.dhe.ibm.com/infocenter/flexsys/information/index.jsp?topic=%2Fcom.lenovo.acc.cmm.doc%2F cmm\\_product\\_page.html](http://pic.dhe.ibm.com/infocenter/flexsys/information/index.jsp?topic=%2Fcom.lenovo.acc.cmm.doc%2F cmm_product_page.html).
- For more information about the Lenovo XClarity Administrator, see <https://support.lenovo.com/us/en/documents/LNVO-XCLARIT>.
- For more information about the Flex System Manager management software, see .

### Notes:

1. Alternatively, you can use the **CMM\_INDICATES\_ITE\_ERROR\_N** command to light the check log LED. See the the Flex System Chassis Management Module: Command-Line Interface Reference Guide at [http://pic.dhe.ibm.com/infocenter/flexsys/information/topic/com.lenovo.acc.cmm.doc/dw1kt\\_cmm\\_cli\\_book.pdf](http://pic.dhe.ibm.com/infocenter/flexsys/information/topic/com.lenovo.acc.cmm.doc/dw1kt_cmm_cli_book.pdf) for more information.
2. You can check the CMM event log to determine the source of the condition. For more information, see “Viewing event logs without restarting the compute node” on page 63.

### Identify LED

The system administrator can remotely light this blue LED to aid in visually locating the compute node. When this LED is lit, the identify LED on the Flex System chassis is also lit. The identify LED can be lit and turned off through the CMM **led** command, the CMM web interface, the Lenovo XClarity Administrator (if available), or the Flex System Manager management software (if available).

- For more information about the CMM **led** command, see the .

- From the CMM web interface, select **Compute Nodes** from the **Chassis Management** menu. All fields and options are described in the CMM web interface online help. For more information, see [http://pic.dhe.ibm.com/infocenter/flexsys/information/index.jsp?topic=%2Fcom.lenovo.acc.cmm.doc%2F\\_cmm\\_product\\_page.html](http://pic.dhe.ibm.com/infocenter/flexsys/information/index.jsp?topic=%2Fcom.lenovo.acc.cmm.doc%2F_cmm_product_page.html).
- For more information about the Lenovo XClarity Administrator, see <https://support.lenovo.com/us/en/documents/LNVO-XCLARIT>.
- For more information about the Flex System Manager management software, see .

### Power button/LED

When the compute node is connected to power through the Flex System chassis, press this button to turn on or turn off the compute node.

**Notes:** The power button works only if local power control is enabled for the compute node. Local power control is enabled and disabled through the CMM **power** command and the CMM web interface.

- For more information about the CMM **power** command, see the .
- From the CMM web interface, select **Compute Nodes** from the **Chassis Management** menu. For more information, see the . All fields and options are described in the CMM web interface online help.

After the compute node is removed from the chassis, press and hold this button to activate the system-board LEDs (light path diagnostics). See “Compute node controls, connectors, and LEDs” on page 13 for more information.

This button is also the power LED. This green LED indicates the power status of the compute node:

- **Flashing rapidly:** The LED flashes rapidly for one of the following reasons:
  - The compute node has been installed in a chassis. When you install the compute node, the LED flashes rapidly for up to 90 seconds while the integrated management module II (IMM2) in the compute node is initializing and synchronizing with the chassis management module.
  - Power permissions have not been assigned to the compute node through the Chassis Management Module.
  - The Flex System chassis does not have enough power to turn on the compute node.
  - The IMM2 in the compute node is not communicating with the Chassis Management Module.
- **Flashing slowly:** The compute node is connected to power through the Flex System chassis and is ready to be turned on.
- **Lit continuously:** The compute node is connected to power through the Flex System chassis and is turned on.

When the compute node is on, pressing this button causes an orderly shutdown of the compute node so that it can be removed safely from the chassis. This includes shutting down the operating system (if possible) and removing power from the compute node.

If an operating system is running, you might have to press the button for approximately 4 seconds to initiate the shutdown.

**Attention:** Pressing the button for 4 seconds forces the operating system to shut down immediately. Data loss is possible.

### NMI button

The NMI button is recessed and can be accessed only by using a small pointed device. Pressing this button causes a nonmaskable interrupt for debugging purposes.

### KVM connector

Connect the console breakout cable to this connector (see “Console breakout cable” on page 16 for more information).

### USB connector

Connect a USB device to this connector.

## Console breakout cable

Use this information for details about the console breakout cable.

Use the console breakout cable to connect external I/O devices to the compute node. The console breakout cable connects through the KVM connector (see “Compute node controls, connectors, and LEDs” on page 13). The console breakout cable has connectors for a display device (video), two USB connectors for a USB keyboard and mouse, and a serial interface connector.

The following illustration identifies the connectors and components on the console breakout cable.

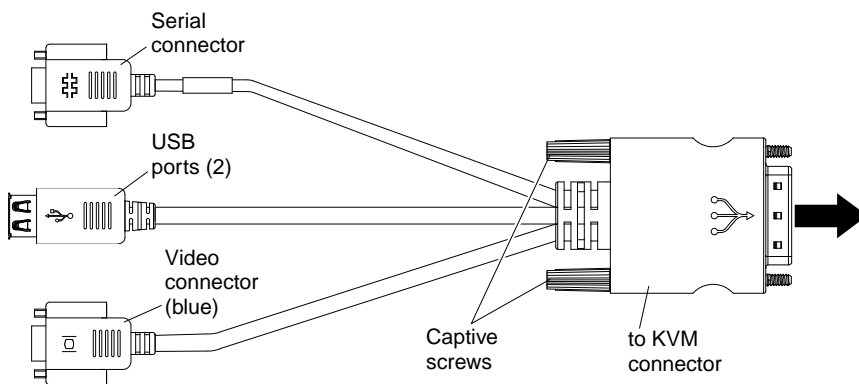

## Turning on the compute node

Use this information for details about turning on the compute node.

After you connect the compute node to power through the Flex System chassis, the compute node can be started in any of the following ways:

- You can press the power button on the front of the compute node (see “Compute node controls, connectors, and LEDs” on page 13) to start the compute node. The power button works only if local power control is enabled for the compute node. Local power control is enabled and disabled through the CMM **power** command and the CMM web interface.
  - For more information about the CMM **power** command, see the .
  - From the CMM web interface, select **Compute Nodes** from the Chassis Management menu. All fields and options are described in the CMM web interface online help. For more information, see the ["Flex System Chassis Management Module: User's Guide" at http://pic.dhe.ibm.com/infocenter/flexsys/information/topic/com.lenovo.acc.cmm.doc/cmm\\_user\\_guide.html](http://pic.dhe.ibm.com/infocenter/flexsys/information/topic/com.lenovo.acc.cmm.doc/cmm_user_guide.html).
- 1. Wait until the power LED on the compute node flashes slowly before you press the power button. While the IMM2 in the compute node is initializing and synchronizing with the Chassis Management Module, the power LED flashes rapidly, and the power button on the compute node does not respond. This process can take approximately 90 seconds after the compute node has been installed.
- 2. While the compute node is starting, the power LED on the front of the compute node is lit and does not flash. See “Compute node controls, connectors, and LEDs” on page 13 for the power LED states.

- If a power failure occurs, the Flex System chassis and the compute node can be configured through the CMM **power** command and the CMM web interface to start automatically when power is restored.
  - For more information about the CMM **power** command, see the .
  - From the CMM web interface, select **Compute Nodes** from the **Chassis Management** menu. For more information, see the "[Flex System Chassis Management Module: User's Guide](http://pic.dhe.ibm.com/infocenter/flexsys/information/topic/com.lenovo.acc.cmm.doc/cmm_user_guide.html)" at [http://pic.dhe.ibm.com/infocenter/flexsys/information/topic/com.lenovo.acc.cmm.doc/cmm\\_user\\_guide.html](http://pic.dhe.ibm.com/infocenter/flexsys/information/topic/com.lenovo.acc.cmm.doc/cmm_user_guide.html). All fields and options are described in the CMM web interface online help.
- You can turn on the compute node through the CMM **power** command, the CMM web interface, the Lenovo XClarity Administrator (if available), or the Flex System Manager management software (if available).
  - For more information about the CMM **power** command, see the .
  - From the CMM web interface, select **Compute Nodes** from the **Chassis Management** menu. All fields and options are described in the CMM web interface online help. For more information, see the "[Flex System Chassis Management Module: User's Guide](http://pic.dhe.ibm.com/infocenter/flexsys/information/topic/com.lenovo.acc.cmm.doc/cmm_user_guide.html)" at [http://pic.dhe.ibm.com/infocenter/flexsys/information/topic/com.lenovo.acc.cmm.doc/cmm\\_user\\_guide.html](http://pic.dhe.ibm.com/infocenter/flexsys/information/topic/com.lenovo.acc.cmm.doc/cmm_user_guide.html).
  - For more information about the Lenovo XClarity Administrator, see <https://support.lenovo.com/us/en/documents/LNVO-XCLARIT>.
  - For more information about the Flex System Manager management software, see .
- You can turn on the computer node through the Wake on LAN feature. The computer node must be connected to power (the power LED is flashing slowly) and must be communicating with the Chassis Management Module. The operating system must support the Wake on LAN feature, and the Wake on LAN feature must be enabled through the Chassis Management Module interface.

## Turning off the compute node

Use this information for details about turning off the compute node.

When you turn off the compute node, it is still connected to power through the Flex System chassis. The compute node can respond to requests from the IMM2, such as a remote request to turn on the compute node. To remove all power from the compute node, you must remove it from the Flex System chassis.

Before you turn off the compute node, shut down the operating system. See the operating-system documentation for information about shutting down the operating system.

The compute node can be turned off in any of the following ways:

- The compute node can turn off automatically as part of the operating system shutdown process (if this feature is supported by the operating system). See your operating-system documentation for more information.
- You can press the power button on the compute node (see "Compute node controls, connectors, and LEDs" on page 13). This starts an orderly shutdown of the operating system, if this feature is supported by the operating system.
- If the operating system stops functioning, you can press and hold the power button for more than 4 seconds to turn off the compute node.

**Attention:** Pressing the power button for 4 seconds forces the operating system to shut down immediately. Data loss is possible.

- You can turn off the compute node through the CMM **power** command, the CMM web interface, the Lenovo XClarity Administrator (if available), or the Flex System Manager management software (if available).
  - For more information about the CMM **power** command, see the .

- From the CMM web interface, select **Compute Nodes** from the **Chassis Management** menu. All fields and options are described in the CMM web interface online help. For more information, see the "[Flex System Chassis Management Module: User's Guide](http://pic.dhe.ibm.com/infocenter/flexsys/information/topic/com.lenovo.acc.cmm.doc/cmm_user_guide.html)" at [http://pic.dhe.ibm.com/infocenter/flexsys/information/topic/com.lenovo.acc.cmm.doc/cmm\\_user\\_guide.html](http://pic.dhe.ibm.com/infocenter/flexsys/information/topic/com.lenovo.acc.cmm.doc/cmm_user_guide.html).
- For more information about the Lenovo XClarity Administrator, see <https://support.lenovo.com/us/en/documents/LNVO-XCLARIT>.
- For more information about the Flex System Manager management software, see .

## System-board layouts

Use this information to locate the connectors, LEDs, jumpers, and switches on the system board.

## System-board connectors

Use this information to locate compute node system-board components and connectors for optional devices.

The following illustration shows the system-board components, including connectors for user-installable optional devices, in the compute node.

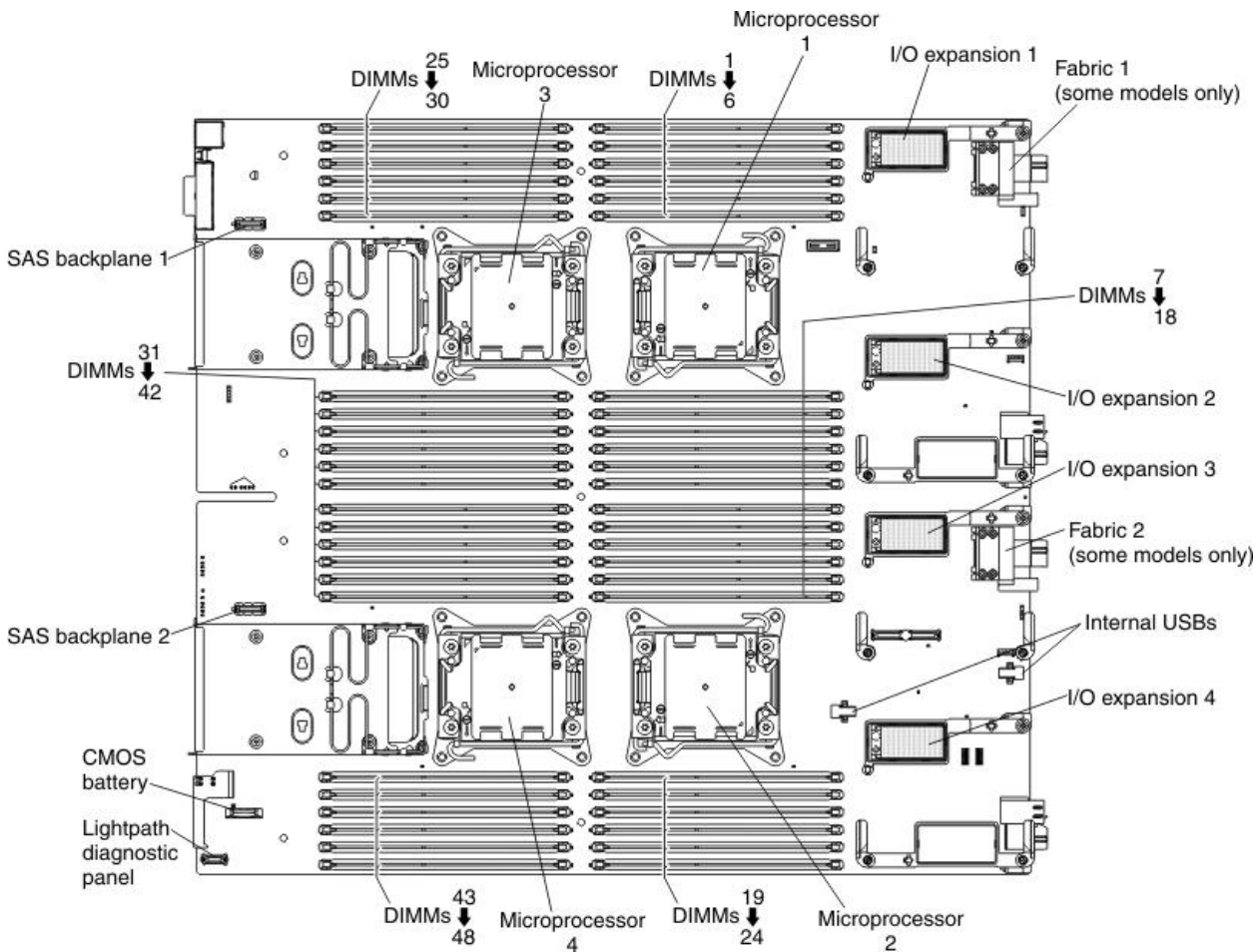

## System-board jumpers

Use this information to locate the system-board jumpers.

The following illustration shows the locations of the jumpers on the system board.

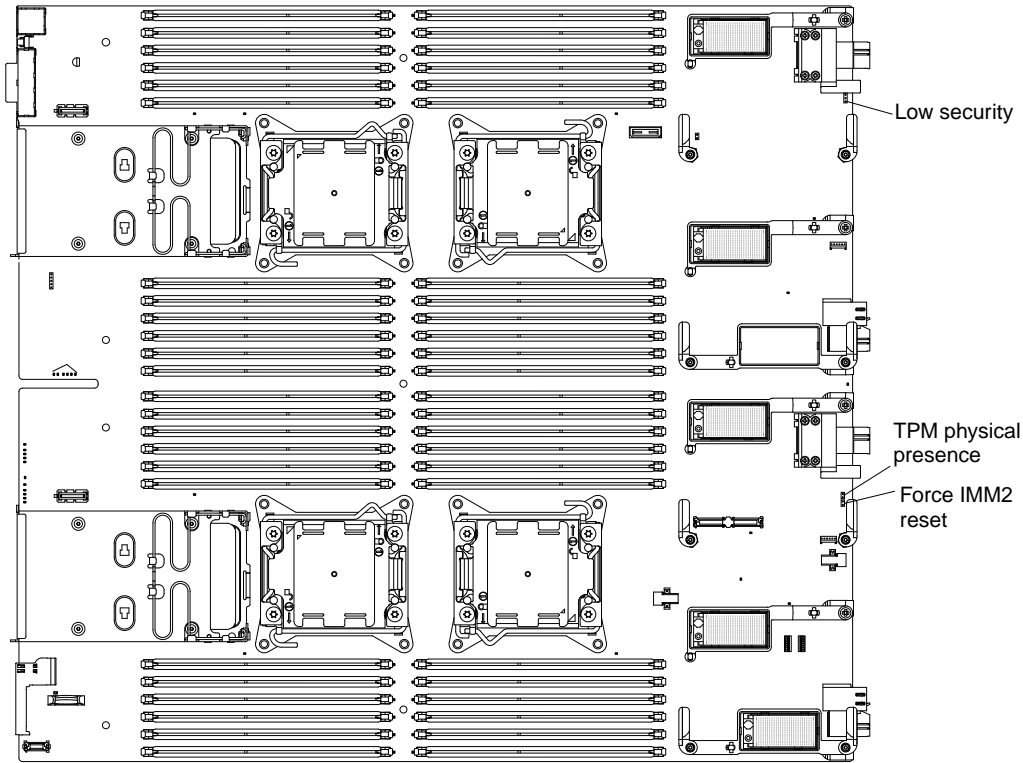

The following table describes the function of each jumper on the system board.

| Jumper number  | Description  |
|--|--|
| Force IMM Reset (J12)                                | For debug purposes only.   |
| Low Security (J9101)                                 | Three-pin jumper block. The default position are pins 2 and 3.   |
| Trusted Platform Module (TPM) physical presence (J6) | Two-pin jumper. The default is no jumper. Place a jumper on pins 1 and 2 to indicate a physical presence to the IMM2 TPM chip. |

## System-board LEDs

The following illustration shows the location of the LEDs on the system board.

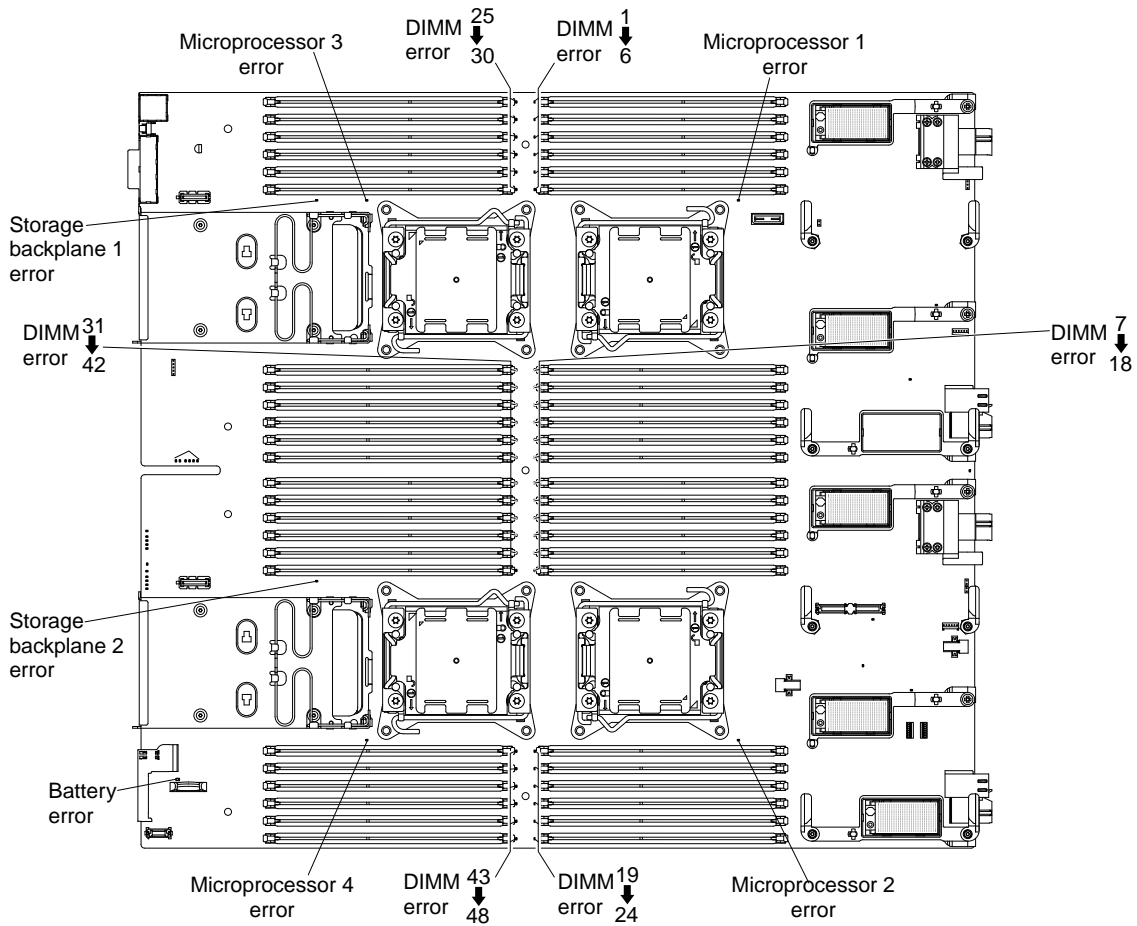

## System-board switches

Use this information to locate the system-board switches.

The following illustration shows the location of the switch block on the system board.



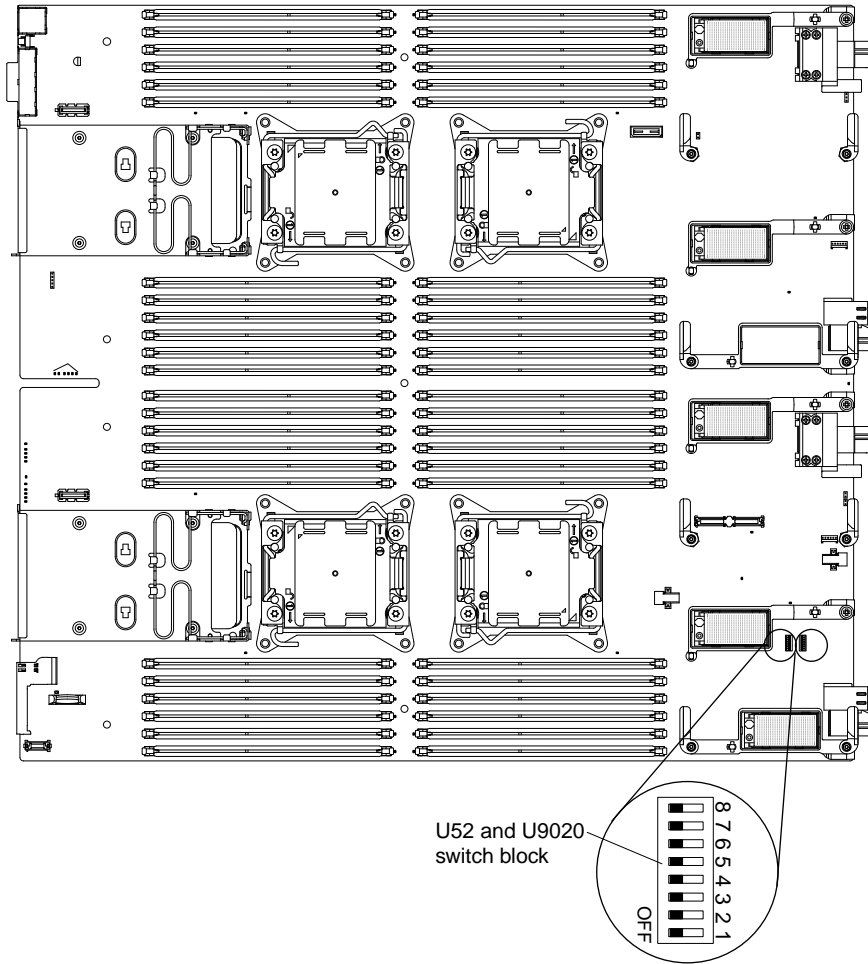

The following table describes the functions of the switches on switch block SW3.

| Switch number | Description                                     | Switch setting                | Definition  |
|---------------|---|-------------------------------|---|
| U52-1         | Password override                               | The default position Open.    | Changing this switch to the Closed position overrides the power-on password.  |
| U52-2         | Trusted Platform Module (TPM) physical presence | The default position is Open. | Changing this switch to the Closed position indicates a physical presence to the TPM.   |
| U52-3         | Real time clock (RTC) reset                     | The default position is Open. | Changing this switch to the Closed position resets the RTC. A momentary toggle is all that is required. To avoid excessive CMOS battery drain, do not leave this switch in the Closed position. |

| Switch number    | Description                                       | Switch setting                                      | Definition   |
|------------------|---|---|--|
| U52-4            | Boot backup IMM2                                  | The default position is Open.                       | When the switch is in the default Open position, the compute node will boot by using the primary IMM2 firmware. When the switch is in the Closed position, the compute node will boot by using a backup of the IMM2 firmware.  |
| U52-5            | Boot backup UEFI                                  | The default position is Open.                       | Changing this switch to the Closed position forces the compute node to boot from the backup UEFI image.  |
| U52-6            | IMM force update                                  | The default position is Open.                       | Changing this switch to the Closed position bypasses the operational firmware image and performs a IMM firmware update, if the normal firmware update procedure results in an inoperative IMM.<br><b>Note:</b> Use this jumper only if the normal firmware update procedure fails and the operational firmware image is corrupted. Use of this jumper disables normal baseboard management controller operation. |
| U52-7            | Wake on LAN (WOL) disable                         | The default position is Open.                       | Changing this switch to the Closed position disables WOL.  |
| U52-8            | Real time management module (RTMM) flash bypass   | The default position is Open.                       | Changing this switch to the Closed position forces the compute node to use RTMM ROM instead of flash.  |
| U9020-1          | Asynchronous reset to configuration logic of FPGA | The default position is Open.                       | Changing this switch to the Closed position resets FPGA Configuration Logic  |
| U9020-2          | Power permission                                  | The default position is Open.                       | Changing this switch to the closed position enables WOL and the front panel button.  |
| U9020-3          | FPGA mux enable                                   | The default position is Open.                       | Changing this switch to the closed position to enable the FPGA MUX keyboard controls   |
| U9020-4          | Future use only                                   |   |  |
| U9020-5, U9020-6 | Selecting dongle serial port MUX (U9812)          | Closed, Closed Open, Closed Closed, Open Open, Open | BE3-1 TX/RXRTMM TX/RXIMM TX/RX SIO TX/RX   |
| U9020-7, U9020-8 | Selecting dongle serial port MUX (U9811)          | Closed, Closed Open, Closed Closed, Open Open, Open | BE3-2 TX/RX FPGA TX/RX IMM TX/RX SIO RTS/CTS   |

---

## Chapter 2. Configuring

Use this information to update the firmware and use the configuration utilities.

---

### Updating firmware and device drivers

Lenovo periodically makes UEFI code, IMM2 firmware, diagnostic firmware updates, and device driver updates available for the compute node. Provisioning is the set of actions that you take to update the firmware and device drivers and install the operating system. Several tools are available to help you update the firmware and device drivers in the provisioning process.

**Attention:** Installing the wrong firmware or device-driver update might cause the compute node to malfunction. Before you install a firmware or device-driver update, read any readme and change history files that are provided with the downloaded update. These files contain important information about the update and the procedure for installing the update, including any special procedure for updating from an early firmware or device-driver version to the latest version.

**Note:** Follow the instructions in the readme file that comes with the firmware update.

- **Lenovo XClarity Administrator**

If a Lenovo XClarity Administrator is available, you can download, install, and manage firmware updates for managed endpoints, including chassis, compute nodes, and I/O modules. You can assign compliance policies to the managed endpoints to ensure that firmware on those endpoints remains compliant.

**Note:** Firmware updates can be applied to the hardware only. You cannot update device drivers using the Lenovo XClarity Administrator.

For more information about using the Lenovo XClarity Administrator, see <https://support.lenovo.com/us/en/documents/LNVO-XCLARIT>.

- **Flex System Manager Update Manager**

Flex System Manager Update Manager (if available) acquires, installs, and manages firmware and device driver updates and monitors your compute nodes to ensure that they remain current. For more information about Flex System Manager Update Manager, see [http://pic.dhe.ibm.com/infocenter/flexsys/information/topic/com.ibm.acc.8731.doc/updating\\_firmware\\_and\\_software.html](http://pic.dhe.ibm.com/infocenter/flexsys/information/topic/com.ibm.acc.8731.doc/updating_firmware_and_software.html).

- **UpdateXpress System Packs**

UpdateXpress System Packs (UXSP) contain an integration-tested bundle of online, updateable firmware and device drivers for your compute node. The Lenovo ToolsCenter Bootable Media Creator uses UpdateXpress System Packs to update the firmware and device drivers.

Typically, use UpdateXpress System Packs to update firmware and devices drivers for a compute node that has previously been provisioned. For more information about UpdateXpress System Packs, see <http://www.ibm.com/support/entry/portal/docdisplay?Indocid=SERV-XPRESS>.

- **Lenovo ToolsCenter Bootable Media Creator**

You can use Lenovo ToolsCenter Bootable Media Creator to create bootable media that is suitable for applying firmware updates and running preboot diagnostics. Using Lenovo ToolsCenter Bootable Media Creator, you can create a single bootable image on supported media (such as CD, DVD, ISO image, USB flash drive, or set of PXE files) that bundles multiple Flex System tools and updates from UpdateXpress System Packs, which contain Windows and Linux® firmware updates.

Typically, use Lenovo ToolsCenter Bootable Media Creator for the initial setup of a compute node. For more information about the Lenovo Bootable Media Creator, see .

To provision a compute node with updated firmware and device drivers by using Lenovo ToolsCenter Bootable Media Creator and the Flex System Manager management software, complete the following steps:

1. Download Lenovo ToolsCenter Bootable Media Creator to a computer that is connected over the management network to the Flex System Manager management software that is managing the compute node.
2. Create the bootable media of firmware and device driver updates.
3. Connect to the Flex System Manager management software that is managing the Flex System chassis in which the compute node is installed.
4. From Flex System Manager Chassis Manager, select the compute node. In the Actions column, select **Remote Control**.

**Note:** The user ID that you use to log in to Flex System Manager management software must have sufficient user permissions to manage the compute node.

5. From the Remote Control session, mount the bootable media (using Remote Media).
6. Start the compute node to boot the media and install the updates.

**Important:** To avoid problems and to maintain system performance, always make sure that the UEFI code, IMM2 firmware, and diagnostic firmware levels are consistent in all compute nodes in the Flex System chassis.

For additional information about updating firmware and device drivers, see [UEFI Compliant Firmware on System x® and BladeCenter® Servers](#) and the [Flex System Quick start guides](#), and the *Firmware Update Guides* at <http://www.ibm.com/support/entry/portal/docdisplay?Indocid=MIGR-5091991> (you might need to register to access this content).

---

## Recovering a UEFI image

Use this information to recover a UEFI image.

The compute node has an advanced recovery feature that automatically switches to a backup UEFI page if the UEFI code in the compute node has become damaged, such as from a power failure during an update. The flash memory of the compute node consists of a primary page and a backup page. If the UEFI code in the primary page is damaged, the integrated management module detects the error and automatically switches to the backup page to start the compute node. If this happens, a POST message *Booted from backup UEFI image* is displayed, the check log LED is lit, and an automatic BIOS recovery (ABR) condition occurs. The backup page version might not be the same as the primary page version.

You can then recover or restore the original primary page UEFI.

**Note:** Changes are made periodically to the Lenovo website. The actual procedure might vary slightly from what is described in this document.

To recover the UEFI code and restore the compute node operation to the primary page, complete the following steps:

- Step 1. Update the UEFI code (see “Updating firmware and device drivers” on page 23).
- Step 2. Restart the compute node.
- Step 3. At the firmware splash screen, press F3 when prompted to restore to the primary bank. The compute node boots from the primary bank.

**Note:** The prompt to press F3 displays only if the compute node boots from the backup page due to an ABR condition.

If the attempt to flash the primary page results in the compute node not booting and the check log LED is not lit, you can manually restore the UEFI code. To manually restore the UEFI code, complete the following steps.

**Note:** If the check log LED is lit, the compute node is booting from the backup image and moving the switch to backup changes nothing.

1. Before you begin, read “Safety” on page iii and “Installation guidelines” on page 827.
2. Turn off the compute node (see “Turning off the compute node” on page 17).
3. Remove the compute node from the Flex System chassis (see “Removing a compute node from a chassis” on page 828).
4. Remove the cover (see “Removing the compute node cover” on page 836).
5. Locate the boot backup UEFI switch on the switch block and move the switch to the On position (see “System-board switches” on page 20).
6. Replace the cover and reinstall the compute node in the Flex System chassis (see “Installing the compute node cover” on page 838 and “Installing a compute node in a chassis” on page 829).
7. Update the UEFI code (see “Updating firmware and device drivers” on page 23).
8. Turn off the compute node and remove it from the Flex System chassis (see “Turning off the compute node” on page 17 and “Removing a compute node from a chassis” on page 828).
9. Remove the cover of the compute node (see “Removing the compute node cover” on page 836).
10. Locate the boot backup UEFI switch on the switch block and move the switch to the Off position (see “System-board switches” on page 20).
11. Replace the cover and reinstall the compute node in the Flex System chassis (see “Installing the compute node cover” on page 838 and “Installing a compute node in a chassis” on page 829).
12. Restart the compute node (see “Turning on the compute node” on page 16).

**Important:** If you are unable to manually restore the UEFI code after several attempts, replace the system board (see “Removing and replacing the base assembly” on page 863).

---

## Configuring the compute node

Use this information to configure the compute node.

To perform a typical initial configuration, complete the following steps:

**Note:** To configure a compute node, you configure the IP address of the IMM through the CMM Web interface. For more information, see the .

- Step 1. Configure the Unified Extensible Firmware Interface (UEFI) firmware for the compute node by using the Setup utility (see “Using the Setup utility” on page 26 or the Advanced Setup Utility (ASU) (see ).

For more information about firmware configuration options, see <http://www.ibm.com/support/entry/portal/docdisplay?Indocid=MIGR-5083207>.

- Step 2. Set the boot protocol by using the Setup utility (see “Setting the boot protocol to boot from legacy devices using the Setup utility” on page 31).

You can temporarily redefine the boot order by using the Boot Selection menu program (see “Using the Boot Selection Menu program” on page 32).

- Step 3. Configure the RAID array.

You can install up to two hard disk drives in the compute node and implement RAID level-0 (striping) or RAID level-1 (mirror) arrays in operating systems that are listed on the ServerProven list

at <http://www.lenovo.com/serverproven/>. For the compute node, you must configure the RAID by using the LSI Configuration Utility program (see “Using the LSI Logic Configuration Utility” on page 36).

If an optional RAID expansion adapter is installed, you can use it to control all the hard disk drives that are installed in the compute node. See the documentation that comes with the expansion adapter for information about how to configure the RAID array.

**Important:** You must create the RAID array *before* you install the operating system on the compute node.

- Step 4. Configure the integrated management module II (IMM2) using either the Setup utility or the Advanced Settings Utility (ASU).
- Step 5. Update the compute node firmware (see “Updating firmware and device drivers” on page 23).

**Note:** If the Chassis Management Module (CMM) and the compute nodes are set up to use DHCP, and the CMM loses connectivity to the network, the CMM attempts to acquire a new IP address when network connectivity is restored. The compute nodes will not attempt to acquire an IP address again; they will continue to use their original IP addresses. Therefore, if you experience network problems on compute nodes after connectivity between the CMM and the network is restored, you might have to reset the service processor on each of the compute nodes in the chassis (including the management node). See “Connectivity problems” on page 800 for more information.

After you configure the compute node, you can install the operating system and update device drivers (see Chapter 3 “Installing the operating system” on page 39 for more information).

## Using the Setup utility

Use these instructions to start the Setup utility.

You can access the Setup utility remotely through the CMM web interface. From the CMM web interface, select **Launch Compute Node Console**. For more information, see the . All fields and options are described in the CMM web interface online help.

**Note:** The integrated management module II (IMM2) must have a valid IP address.

To start the Setup utility locally, complete the following steps:

- Step 1. If the compute node is turned on, turn off the compute node (see “Turning off the compute node” on page 17).
- Step 2. If necessary, connect a keyboard, monitor, and mouse to the console breakout cable and connect the console breakout cable to the compute node).
- Step 3. Turn on the compute node (see “Turning on the compute node” on page 16).
- Step 4. When the prompt Press <F1> Setup is displayed, press F1. If you have set an administrator password, you must type the administrator password to access the full Setup utility menu. If you do not type the administrator password, a limited Setup utility menu is available.
- Step 5. Follow the instructions on the screen.

The following menu items are on the Setup utility main menu. Depending on the version of the Unified Extensible Firmware Interface (UEFI), some menu items might differ slightly from these descriptions.

- **System Information**

Select this choice to view information about the compute node. When you make changes through other choices in the Setup utility, some of those changes are reflected in the system information; you cannot change settings directly in the system information. This choice is on the full Setup utility menu only.

- **System Summary**

Select this choice to view configuration information, including the ID, speed, and cache size of the microprocessors, machine type and model of the compute node, the serial number, the system Universally Unique Identifier (UUID), and the amount of installed memory.

- **Product Data**

Select this choice to view the system-board identifier, the revision level or issue date of the firmware, the integrated management module II and diagnostics code, and the version and date.

This choice is on the full UEFI Setup utility menu only.

- **System Settings**

Select this choice to view or change the compute node component settings.

- **Adapters and UEFI Drivers**

Select this choice to view information about the adapters and UEFI device drivers in the compute node.

**Note:** Before you configure a UEFI-compatible device, update the firmware for your compute node. See “Updating firmware and device drivers” on page 23 for information about how to update the firmware for your compute node.

To configure a UEFI-compatible expansion adapter, complete the following steps:

1. Select **Please refresh this page first** and press Enter.
2. Select the device driver that you want to configure, and press Enter.
3. When you have finished changing settings, press Esc to exit from the program; select **Save** to save the settings that you have changed.

- **Processors**

Select this choice to view or change the microprocessor settings.

- **Memory**

Select this choice to view or change the memory settings.

If a memory error is detected during POST or memory configuration, the compute node automatically disables the failing pair of memory connectors and continues operating with reduced memory. After the problem is corrected, you must manually enable the memory connectors. Select **System Memory Details** and use the arrow keys to highlight the pair of memory connectors that you want to enable; then, set the connectors to **Enable**.

- **Devices and I/O Ports**

Select this choice to view or change assignments for devices and input/output (I/O) ports. You can configure the remote console redirection and enable or disable integrated Ethernet controllers. If you disable a device, it cannot be configured, and the operating system cannot detect it (disabling a device is equivalent to disconnecting the device).

You can also choose to enable or disable adapter option ROM support. Disabling support can potentially improve the time it takes the compute node to start.

- **Power**

Select this choice to view or change Active Energy Manager (AEM) power capping to control power consumption and microprocessor performance states.

- **Boot Modes**

Select this choice to view or change the boot settings. You can set the boot mode and choose UEFI operating system support only, legacy (BIOS) operating system support only, or UEFI and legacy operating system support.

**Note:** If you select the legacy only boot mode (which makes boot time much faster), you will not be able to activate any feature on demand (FoD) keys.

– **Operating Modes**

Select this choice to determine operational settings, such as operating mode (acoustic, efficiency, or performance) and memory speed.

– **Legacy Support**

Select this choice to view or set legacy support.

**Notes:** In the legacy mode, the system has limited ROM space for installed options. Legacy PXE boot supports up to four network interface card (NIC) ports. If more than four NIC ports are occupied, legacy PXE boot will not be attempted on the fifth NIC port and following ports. There are two ways to enable legacy PXE boot on the desired NIC ports:

1. Prioritize the desired NIC connectors by changing the **ROM execution Order**.
  - The path to **ROM execution Order: Main menu>System Settings>Devices and I/O Ports>Set Option ROM Execution Order>ROM execution Order**
2. Disable the NIC connector's legacy option ROM that you do not use from the **Enable/Disable Adapter Option ROM Support** menu to prioritize the desired NIC port to be 4 functional ports.
  - The path to **Enable/Disable Adapter Option ROM Support: Main menu>System Settings>Devices and I/O Ports>Enable/Disable Adapter Option ROM support**

– **Force Legacy Video on Boot**

Select this choice to enable or disable force INT video support, if the operating system does not support UEFI video output standards. The default is **Enable**.

– **Rehook INT**

Select this choice to enable or disable devices from taking control of the boot process. The default is **Disable**.

– **Legacy Thunk Support**

Select this choice to enable or disable UEFI to interact with PCI mass storage devices that are non-UEFI compliant. The default is **Enable**.

– **Infinite Boot Retry**

Select this choice to enable or disable UEFI to infinitely retry the legacy boot order.

– **Non-Planar PXE**

Select this choice to enable or disable non-system-board PXE for legacy mode.

– **System Security**

Select this option to view or change the following system security configuration.

– **Physical Presence Policy Configuration**

Select this choice to choose from the following Physical Presence Policy options.

- **Enable/Disable:** select this option to enable/disable Physical Presence Policy. Default is **Enable**.
- **Asserted:** select this option to set Physical Presence for a duration (in minutes) or turn it off. Default is **De-asserted**.
- **Input minutes for assertion:** select this option to input a number from 0~100 which stands for the number of minutes Remote Physical Presence is asserted. Physical Presence Policy has to be enabled before this option is available.
- **Refresh assert status:** select this option to view the current status of asserting.

– **Rollback Configuration**



Select this choice to allow (enable)/forbid(disable) rolling back to an older version of UEFI. Default is **Enable**.

#### – **Secure Boot Configuration**

Select this choice to choose from the following Secure Boot options.

- **Enable/Disable:** select this option to enable/disable Secure Boot. Default is **Disable**.
- **Secure Boot Mode:** select this option to choose a mode of Secure Boot. Default is **Standard Mode**.
  - **Standard Mode:** standard mode of Secure Boot.
  - **Custom Secured Boot Mode:** the following options are available in this mode:
    - **Display Secure Boot Option ROM error:** to show a list of devices in the server that are not signed for Secure Boot.
    - **PK (platform key) options:** to enroll/delete PK
    - **KEK (Key Enrollment Key) options:** to enroll/delete KEK
    - **DB (Signatures Database) options:** to enroll/delete DB
    - **DBX (Revoked Signatures Database) options:** to enroll/delete DBX

#### – **Trusted Platform Module (TPM 1.2)**

Select this choice to view or change the settings of TPM 1.2.

- **TPM firmware version:** to view current TPM firmware version.
- **TPM device/state :** to view current state of TPM or activate/deactivate TPM.
- **Refresh TPM Status:** to get the current status of TPM.
- **TPM force clear:** to force clearing TPM data.

#### – **Integrated Management Module**

Select this choice to view or change the settings for the integrated management module II (IMM2).

##### – **Commands on USB Interface**

Select this choice to specify whether the Ethernet over USB interface is enabled or disabled.

**Notes:** This option is primarily for older operating systems that have problems with USB communications device class (CDC) Ethernet interfaces. Disabling this option will cause the following issues:

- Online update packages will not work.
- Updates that use Bootable Media Creator (BoMC) will not work because BoMC uses the LAN over USB interface.
- You must install the IPMI device driver to use the Advanced Settings Utility (ASU) to change the IMM2 or UEFI configuration.
- You cannot set the IMM2 OS loader watchdog.

##### – **Network Configuration**

Select this choice to view the system-management network interface port, IMM2 MAC address, current IMM2 IP address, and host name; define the static IMM2 IP address, subnet mask, and gateway address; specify whether to use the static IP address or have DHCP assign the IMM2 IP address; save the network changes; and reset the IMM2.

##### – **Reset IMM to Defaults**

Select this choice to restore the IMM2 to the manufacturing default settings. The IMM2 controller restarts after you restore the settings.

##### – **Reset IMM**

Select this choice to restart the IMM2 controller.

– **Recovery**

Select this choice to view or change the system recovery parameters.

– **POST Attempts**

Select this choice to define the number of times to attempt POST before invoking the recovery procedures.

– **System Recovery**

Select this choice to configure the recovery settings.

• **POST Watchdog Timer**

Select this choice to view or enable the POST watchdog timer.

• **POST Watchdog Timer Value**

Select this choice to view or set the POST loader watchdog timer value.

• **Reboot System on NMI**

Select this choice to enable or disable restarting the system whenever a nonmaskable interrupt (NMI) occurs. The default is **Disable**.

– **Storage**

Select this choice to view or change the storage device settings.

– **Network**

Select this choice to view or change the network device options, such as iSCSI.

– **Driver Health**

Select this choice to view the health status of the controllers as reported by the device drivers. You can select to perform a repair action on a device driver.

• **Date and Time**

Select this choice to set the date and time for the compute node. The date is set in *month/day/year* format. The time is set in 24-hour format (*hour:minute:second*).

This choice is on the full UEFI Setup utility menu only.

• **Start Options**

Select this choice to view or change the startup sequence. The startup sequence specifies the order in which the compute node checks devices to find a boot record. The compute node starts from the first boot record that it finds. If the compute node has Wake on LAN hardware and software and the operating system supports Wake on LAN functions, you can specify a startup sequence for the Wake on LAN functions. For example, you can define a startup sequence that checks for a disc in the CD or DVD drive, then checks the hard disk drive, and then checks a network adapter.

This choice is on the full UEFI Setup utility menu only.

• **Boot Manager**

Select this choice to view, add, delete, or change the device boot priority, boot from a file, select a one-time boot, or reset the boot order to the default setting.

• **System Event Logs**

Select this choice to access the System Event Manager, where you can view the POST event log and the system-event log.

The POST event log contains the three most recent error codes and messages that were generated during POST.

The system-event log contains POST and system management interrupt (SMI) events and all events that are generated by the baseboard management controller that is embedded in the integrated management module II.

**Important:** If the system-error LED on the front of the compute node is lit but there are no other error indications, clear the system-event log. Also, after you complete a repair or correct an error, clear the system-event log to turn off the system-error LED on the front of the compute node.

- **POST Event Viewer**

Select this choice to enter the POST event viewer to view the UEFI diagnostic codes.

- **System Event Log**

Select this choice to view the system-event log.

- **Clear System Event Log**

Select this choice to clear the system-event log.

- **User Security**

Select this choice to set, change, or clear passwords.

You can set, change, and delete a power-on password and an administrator password through this selection. If you set a power-on password, you must type the power-on password to complete the system startup and to have access to the Setup utility menu.

You can use any combination of up to from 6 to 20 characters (A - Z, a - z, and 0 - 9) for passwords. Keep a record of your password in a secure place.

If you forget the power-on password, you can regain access to the compute node either by removing the CMOS battery and then reinstalling it (see “Removing the CMOS battery” on page 834 and “Installing the CMOS battery” on page 835) or by using the power-on password override switch (see “System-board switches” on page 20).

**Attention:** If you set an administrator password and then forget it, there is no way to change, override, or remove it. You must replace the system board.

- **Save Settings**

Select this choice to save the changes that you have made in the settings.

- **Restore Settings**

Select this choice to cancel the changes that you have made in the settings and restore the previous settings.

- **Load Default Settings**

Select this choice to cancel the changes that you have made in the settings and restore the manufacturing settings.

- **Exit Setup**

Select this choice to exit from the Setup utility. If you have not saved the changes that you have made in the settings, you are asked whether you want to save the changes or exit without saving them.

## Setting the boot protocol to boot from legacy devices using the Setup utility

This option disables UEFI ROMs from loading. The compute node will boot legacy mode only. Use the Setup utility to configure the boot protocol to boot from a non-UEFI legacy network device for all PXE boot attempts.

To use the Setup utility to configure the boot protocol to boot from a non-UEFI legacy network device for all PXE boot attempts, complete the following steps:

1. Connect a keyboard, monitor, and mouse to the console breakout cable and connect the console breakout cable to the compute node.
2. Turn on the compute node (see “Turning on the compute node” on page 16).
3. When the prompt Press <F1> Setup is displayed, press F1. If you have set an administrator password, you must type the administrator password to access the full Setup utility menu. If you do not type the administrator password, a limited Setup utility menu is available.
4. From the Setup utility main menu, select **Boot Manager Settings**.
5. Select **Boot Modes**; then, select **Legacy Only**.
6. Press Esc twice to return to the Setup utility main menu.
7. Select **Save Settings** and then select **Exit Setup**.

To use the Setup utility to configure the boot protocol to boot from a non-UEFI legacy network device, complete the following steps:

1. Connect a keyboard, monitor, and mouse to the console breakout cable and connect the console breakout cable to the compute node.
2. Turn on the compute node (see “Turning on the compute node” on page 16).
3. When the prompt Press <F1> Setup is displayed, press F1. If you have set an administrator password, you must type the administrator password to access the full Setup utility menu. If you do not type the administrator password, a limited Setup utility menu is available.
4. From the Setup utility main menu, select **Boot Manager**.
5. Select **Add Boot Option**; then, select **Generic Boot Option**.
6. Select **Legacy Only**.
7. Move the non-UEFI legacy network device to the top of the boot order.
8. Press Esc three times to return to the Setup utility main menu.
9. Select **Save Settings** and then, select **Exit Setup**.

## Using the Boot Selection Menu program

The Boot Selection Menu program is a built-in, menu-driven configuration utility program that you can use to temporarily redefine the first startup device without changing settings in the Setup utility.

To use the Boot Selection Menu program, complete the following steps:

- Step 1. Connect a keyboard, monitor, and mouse to the console breakout cable, and connect the console breakout cable to the compute node.
- Step 2. Turn on the compute node (see “Turning on the compute node” on page 16).
- Step 3. Press F12 (**Select Boot Device**). If a bootable USB mass storage device is installed, a submenu item (**USB Key/Disk**) is displayed.
- Step 4. Use the Up Arrow and Down Arrow keys to select an item from the Boot Selection Menu and press **Enter**.

The next time the compute node starts, it returns to the startup sequence that is set in the Setup utility.

## Updating the Universally Unique Identifier and DMI/SMBIOS data

After the system board is replaced, you must update the Universally Unique Identifier (UUID) and DMI/SMBIOS data in the integrated management module II (IMM2) on the new system board.

You can use the Advanced Settings Utility (ASU) and any of the following access methods:

- Locally (in-band)

- Through the Keyboard Controller Style (KCS) interface
- Through the LAN over USB interface
- Remotely over a LAN

You can use the ASU under any supported operating system, or you can use the Bootable Media Creator or a Windows- or Linux-based toolkit to create bootable media that contains the ASU. For information about the ASU and instructions for downloading and unpacking the ASU code, see and the *Advanced Settings Utility User's Guide*.

The following sections provide instructions for updating the UUID and DMI/SMBIOS data, using the different methods for accessing the IMM2. The following conventions apply to the command syntax:

- Variables are shown in *italics*.
- Optional parameters are enclosed in brackets ([ ]). Do not type the brackets in the commands. If you omit an optional parameter, the default is used.
- Although the command syntax is shown in mixed case, the commands are not case sensitive.

### Locally: Keyboard Controller Style (KCS)

This access method uses the IPMI/KCS interface. The IPMI driver must be installed; with some operating systems, the IPMI driver is installed by default. The ASU provides the corresponding mapping layer.

To update the UUID, in the ASU command-line interface, enter the following command:

```
asu set SYSTEM_PROD_DATA.SysInfoUUID uuid
```

where *uuid* is the user-assigned hexadecimal value, up to 16 bytes, that identifies the compute node.

To update the DMI/SMBIOS data, complete the following steps:

Step 1. In the ASU command-line interface, enter the following command:

```
asu set SYSTEM_PROD_DATA.SysInfoProdName xxxxyyy
```

where:

*xxxx*

is the 4-digit machine type of the compute node.

*yyy*

is the 3-digit model number of the compute node.

Step 2. Enter the following command:

```
asu set SYSTEM_PROD_DATA.SysInfoSerialNum zzzzzzz
```

where *zzzzzzz* is the 7-character serial number of the compute node.

Step 3. Enter the following command:

```
asu set SYSTEM_PROD_DATA.SysEncloseAssetTag  
aaaaaaaaaaaaaaaaaaaaaaaaaaaaaaaaaaaa
```

where *aaaaaaaaaaaaaaaaaaaaaaaaaaaaaaaaaaaa* is the 33-character asset tag number of the compute node.

Step 4. Restart the IMM.

Step 5. Restart the server.

### Locally: LAN over USB

If you omit any optional parameter, the default value is used. If one or more default values are used and the ASU cannot access the IMM2 by using the LAN over USB access method, the ASU automatically uses the KCS access method.

To update the UUID, in the ASU command-line interface, enter the following command:

```
asu set SYSTEM_PROD_DATA.SysInfoUUID uuid [--user userid][--password password]
```

where:

*uuid*

is the user-assigned hexadecimal value, up to 16 bytes, that identifies the compute node.

*userid*

is the IMM2 account name (1 of 12 accounts). The default is USERID.

*password*

is the IMM2 account password (1 of 12 accounts). The default is PASSWORD (with a zero, not the letter O).

To update the DMI/SMBIOS data, complete the following steps:

Step 1. In the ASU command-line interface, enter the following command:

```
asu set SYSTEM_PROD_DATA.SysInfoProdName xxxxyyy [--host ipaddress] [--user userid][--password password]
```

where:

*xxxx*

is the 4-digit machine type of the compute node.

*yyy*

is the 3-digit model number of the compute node.

*ipaddress*

is the internal LAN/USB IP address of the IMM2. The default is 169.254.95.118.

*userid*

is the IMM2 account name (1 of 12 accounts). The default is USERID.

*password*

is the IMM2 account password (1 of 12 accounts). The default is PASSWORD (with a zero, not the letter O).

Step 2. Enter the following command:

```
asu set SYSTEM_PROD_DATA.SysInfoSerialNum zzzzzzz [--host ipaddress] [--user userid][--password password]
```

where *zzzzzzz* is the 7-character serial number of the compute node.

Step 3. Enter the following command:

```
asu set SYSTEM_PROD_DATA.SysEncloseAssetTag aaaaaaaaaaaaaaaaaaaaaaaaaaaaaaaaaaaa [--host ipaddress] [--us
```

where *aaaaaaaaaaaaaaaaaaaaaaaaaaaaaaaaaaaa* is the 33-character asset tag number of the compute node.

Step 4. Restart the IMM.

Step 5. Restart the server.

## Remotely over a LAN

If you omit any optional parameter, the default value is used.

To update the UUID, in the ASU command-line interface, enter the following command:

```
asu set SYSTEM_PROD_DATA.SysInfoUUID uuid --host ipaddress [--user userid][--password password]
```

where:

*uuid*

is the user-assigned hexadecimal value, up to 16 bytes, that identifies the compute node.

*ipaddress*

is the external LAN IP address of the IMM2.

*userid*

is the IMM2 account name (1 of 12 accounts). The default is USERID.

*password*

is the IMM2 account password (1 of 12 accounts). The default is PASSWORD (with a zero, not the letter O).

To update the DMI/SMBIOS data, complete the following steps:

Step 1. In the ASU command-line interface, enter the following command:

```
asu set SYSTEM_PROD_DATA.SysInfoProdName xxxxyyy --host ipaddress [--user userid][--password password]
```

where:

*xxxx*

is the 4-digit machine type of the compute node.

*yyy*

is the 3-digit model number of the compute node.

*ipaddress*

is the external LAN IP address of the IMM2.

*userid*

is the IMM2 account name (1 of 12 accounts). The default is USERID.

*password*

is the IMM2 account password (1 or 12 accounts). The default is PASSWORD (with a zero, not the letter O).

Step 2. Enter the following command:

```
asu set SYSTEM_PROD_DATA.SysInfoSerialNum zzzzzzz --host ipaddress [--user userid][--password password]
```

where *zzzzzzz* is the 7-character serial number of the compute node.

Step 3. Enter the following command:

```
asu set SYSTEM_PROD_DATA.SysEncloseAssetTagaaaaaaaaaaaaaaaaaaaaaaaaaaaaaaaaaaaa --host ipaddress [--us
```

where *aaaaaaaaaaaaaaaaaaaaaaaaaaaaaaaaaaaa* is the 33-character asset tag number of the compute node.

Step 4. Restart the IMM.

Step 5. Restart the server.

## Configuring a RAID array

Use this information to configure a RAID array.

Configuring a RAID array applies only to a compute node in which two or more hard disk drives are installed.

**Note:** When you configure a RAID array, the hard disk drives must use the same type of interface. For example, a RAID array can be configured with two SAS hard disk drives or two SATA hard disk drives.

You can use two hard disk drives in the compute node to implement and manage RAID level-0 (striping) or RAID level-1 (mirror) arrays in operating systems that are listed on the ServerProven list at <http://www.lenovo.com/serverproven/>. For the compute node, you must configure the RAID by using the LSI Configuration Utility program.

If an optional RAID expansion adapter is installed, you can use it to control all of the hard disk drives that are installed in the compute node. See the documentation that comes with the expansion adapter for information about how to configure the RAID array.

**Important:** You must create the RAID array *before* you install the operating system on the compute node.

You can use the LSI Logic Configuration Utility program to configure the hard disk drives and the SAS controller. To start the LSI Logic Configuration Utility, see “Using the LSI Logic Configuration Utility” on page 36.

## Using the LSI Logic Configuration Utility

Use these instructions to start the LSI Logic Configuration Utility.

You can use the LSI Logic Configuration Utility to perform the following tasks:

- Set the device boot order
- Add or remove devices from the boot list
- Manage the RAID configuration

**Note:** The hard disk drive in the RAID configuration must use the same type of interface and must have identical capacity and speed.

To start the LSI Logic Configuration Utility program, complete the following steps:

- Step 1. Connect a keyboard, monitor, and mouse to the console breakout cable and connect the console breakout cable to the compute node.
- Step 2. Turn on the compute node (see “Turning on the compute node” on page 16).
- Step 3. When the prompt Press <F1> Setup is displayed, press F1. If you have set an administrator password, you must type the administrator password to access the full Setup utility menu. If you do not type the administrator password, a limited Setup utility menu is available.
- Step 4. From the Setup utility main menu, select **System Settings**; then select **Storage**.
- Step 5. Use the arrow keys to select the controller from the list of adapters; then, press Enter.
- Step 6. Follow the instructions on the screen to change the settings of the selected items; then, press Enter. If you select **SAS Topology** or **Advanced Adapter Properties**, additional screens are displayed.

## Setting up the LAN-on-motherboard (LOM) feature

This topic provides information about setting up the LAN-on-motherboard (LOM) feature.

Some models of the x440 Compute Node Types 7167 and 2590 have an Ethernet LAN-on-motherboard (LOM) controller integrated on the system board. The LOM provides the following features:

- Two operational mode choices:
  - One-port physical NIC mode (pNIC), multichannel disabled, which is the default.
  - Virtual NIC mode (vNIC), multichannel enabled. vNIC mode enables up to 4 virtual NIC interfaces per 10 Gb physical port (8 total for the LOM).



For more information about how LOM ports are mapped to switch modules in the chassis, see .

- Two options for vNIC linking:
  - VNIC1, Virtual Fabric mode.
  - VNIC2, Switch Independent mode.

You can select these options using the Setup utility (F1).

- Link auto negotiation 10 Gb/1 Gb full duplex.
- Bus-mastering support.
- Direct memory access (DMA) support.
- Interoperability with existing FC SAN infrastructures, such as switches, arrays, SRM tools (including Emulex utilities), SAN practices, and other infrastructures.
- Unified Ethernet-to-FC SAN connectivity provided by an FCoE switch.
- 10 Gb MAC features such as MSI-X support, jumbo frames (8 KB) support, VLAN tagging (802.1Q, PER priority pause/priority flow control), and advanced packet filtering.
- NIC failover support.
- Support for IBM Fabric Manager (IFM).
- Preboot Execution Environment, UEFI, and Legacy PXE.
- Wake on LAN (WOL).
- SRIOV support.
- iSCSI or FCoE capabilities, which can be enabled through Features on Demand. When enabled, the iSCSI or FCoE operations are supported on the second vNIC of the physical port.

Separate NIC, iSCSI, and FCoE drivers are provided to support all configurations. To obtain the device drivers, go to <http://www.emulex.com/downloads/oemqualified/ibm/vfafc-software-kits/>.

No host operating system changes are required for you to use the LOM features. NIC and HBA functionality (including device management, utilities, and other functions) are transparent to the host operating system.

For more information about using the LOM feature, go to <http://www.emulex.com/support/>.



---

## Chapter 3. Installing the operating system

Use these instructions to install the operating system on the compute node.

To determine which operating systems are supported, go to <http://www.lenovo.com/serverproven/>.

Provisioning is the set of actions that you take to install the operating system. To install the operating system on a compute node, you can use any of the following methods:

- **Lenovo ServerGuide Setup and Installation CD**

Use the *ServerGuide Setup and Installation* CD to install a supported Microsoft Windows operating system only. To provision a compute node with an operating system by using the *ServerGuide Setup and Installation* CD, complete the following steps.

1. Download the *ServerGuide Setup and Installation* CD ISO image to a computer that is connected over the management network to the Flex System Manager management software (if installed) that is managing the compute node.
2. Connect to the Flex System Manager management software that is managing the Flex System chassis in which the compute node is installed.
3. From Flex System Manager Chassis Manager, select the compute node. In the Actions column, select **Remote Control**.

**Note:** The user ID that you use to log in to Flex System Manager management software must have sufficient user permissions to manage the compute node.

4. From the Remote Control session, mount the *ServerGuide Setup and Installation* CD bootable media (using Remote Media). When the ServerGuide program prompts you to mount the operating-system image, unmount the *ServerGuide Setup and Installation* CD and mount the operating-system image. You can also install an ISO image of the operating system from an external or portable storage device, such as a USB device, by using Remote Media. For more information, see .
5. Start the compute node to boot the media and install the operating system.

- **Lenovo ToolsCenter Bootable Media Creator**

Use Lenovo ToolsCenter Bootable Media Creator to create an Lenovo *ServerGuide Setup and Installation* CD for deploying Windows operating systems and updates from UpdateXpress System Packs. For more information about the Lenovo Bootable Media Creator, see .

To provision a compute node with an operating system by using Lenovo ToolsCenter Bootable Media Creator, complete the following steps:

1. Download Lenovo ToolsCenter Bootable Media Creator to a computer that is connected over the management network to the Flex System Manager management software that is managing the compute node.
2. Connect to the Flex System Manager management software (if installed) that is managing the Flex System chassis in which the compute node is installed.
3. From Flex System Manager Chassis Manager, select the compute node. In the Actions column, select **Remote Control**.

**Note:** The user ID that you use to log in to Flex System Manager management software must have sufficient user permissions to manage the compute node.

4. From the Remote Control session, mount the *ServerGuide Setup and Installation* CD bootable media (using Remote Media). When the ServerGuide program prompts you to mount the operating-system image, unmount the *ServerGuide Setup and Installation* CD and mount the operating-system image.

You can also install an ISO image of the operating system from an external or portable storage device, such as a USB device, by using Remote Media. For more information, see .

5. Start the compute node to boot the media and install the operating system.

- **Lenovo XClarity Administrator**

You can use the Lenovo XClarity Administrator (if available) to deploy operating systems and virtual images to multiple compute nodes that do not already have an operating system installed. This function allows you to deploy Red Hat Enterprise Linux (RHEL) including Kernel-based Virtual Machine (KVM), VMware vSphere Hypervisor (ESXi) with Lenovo Customization, and Microsoft Windows 2012. For more information, see <https://support.lenovo.com/us/en/documents/LNVO-XCLARIT>.

- **Flex System Manager management software**

You can also use Flex System Manager management software (if available) to deploy operating system and virtual images to multiple compute nodes that do not already have an operating system installed. This function is limited to deploying VMware ESXi and RHEL KVM hypervisors. For more information, see .

- **Lenovo ServerGuide Scripting Toolkit**

The ServerGuide Scripting Toolkit is a collection of system-configuration tools and installation scripts that you can use to deploy software to your compute node in a repeatable, predictable manner (see “Using Lenovo ServerGuide Scripting Toolkit” on page 41).

- **Operating-system installation instructions**

Download the latest operating-system installation instructions and install the operating system.

**Important:** The operating system in the compute node must provide USB support for the compute node to recognize and use the keyboard, mouse, and removable-media drives.

---

## Using the ServerGuide Setup and Installation CD

The *ServerGuide Setup and Installation CD* provides software setup tools and installation tools that are designed for your compute node. The ServerGuide program detects the compute node model and optional hardware devices that are installed and uses that information during setup to configure the hardware. The ServerGuide program simplifies operating-system installations by providing updated device drivers and, in some cases, installing them automatically.

You can download a free image of the *ServerGuide Setup and Installation CD* from <http://www.ibm.com/support/entry/portal/docdisplay?Indocid=SERV-GUIDE>.

In addition to the *ServerGuide Setup and Installation CD*, you must have your operating-system CD to install the operating system.

## ServerGuide features

This information provides an overview of the ServerGuide features.

Features and functions can vary slightly with different versions of the ServerGuide program. To learn more about the version that you have, start the *ServerGuide Setup and Installation CD* and view the online overview. Not all features are supported on all compute node models.

The ServerGuide program has the following features:

- An easy-to-use interface
- Diskette-free setup, and configuration programs that are based on detected hardware
- Device drivers that are provided for the compute node model and detected hardware
- Operating-system partition size and file-system type that are selectable during setup

The ServerGuide program performs the following tasks:

- Sets system date and time
- Detects installed optional hardware devices and provides updated device drivers for most adapters and devices
- Provides diskette-free installation for supported Windows operating systems
- Includes an online readme file with links to tips for hardware and operating-system installation

## Typical operating-system installation

The ServerGuide program can reduce the time it takes to install an operating system. It provides the device drivers that are required for your hardware and for the operating system that you are installing. This section describes a typical ServerGuide operating-system installation.

**Note:** Features and functions can vary slightly with different versions of the ServerGuide program.

1. After you have completed the setup process, the operating-system installation program starts. (You will need your operating-system CD to complete the installation.)
2. The ServerGuide program stores information about the compute node model, IMM2, hard disk drive controllers, and network adapters. Then, the program checks the CD for newer device drivers. This information is stored and then passed to the operating-system installation program.
3. The ServerGuide program presents operating-system partition options that are based on your operating-system selection and the installed hard disk drives.
4. The ServerGuide program prompts you to insert your operating-system CD and restart the compute node. At this point, the installation program for the operating system takes control to complete the installation.

## Installing the operating system without using ServerGuide

Use this information to install the operating system on the compute node without using ServerGuide.

If you have already configured the compute node hardware and you are not using the ServerGuide program to install your operating system, you can download operating-system installation instructions for the compute node from <http://www.lenovo.com/support>.

---

## Using Lenovo ServerGuide Scripting Toolkit

The ServerGuide Scripting Toolkit is a collection of system-configuration tools and installation scripts that you can use to deploy software to your Flex System compute node in a repeatable, predictable manner. When the ServerGuide Scripting Toolkit is used with ServerGuide, it provides a total solution for deploying Flex System compute nodes in an unattended mode.

For more information about using the ServerGuide Scripting Toolkit, see .



---

## Chapter 4. Accessing the IMM2

Use this information to access the integrated management module II (IMM2) remotely by using the command-line interface (IPMI shell) or serial over LAN, or locally through the LAN over USB interface.

The IMM2 is a second generation of the functions that were formerly provided by the baseboard management controller hardware. It combines service processor functions, video controller, and remote presence function in a single chip.

For more information about the IMM2, see [http://publib.boulder.ibm.com/infocenter/systemx/documentation/topic/com.lenovo.sysx.imm2.doc/printable\\_doc.html](http://publib.boulder.ibm.com/infocenter/systemx/documentation/topic/com.lenovo.sysx.imm2.doc/printable_doc.html)

---

### Accessing the IMM2 remotely

The integrated management module II (IMM2) provides remote systems-management capabilities.

- **Command-line interface**

The command-line interface provides direct access to systems-management functions through the IPMI 2.0 protocol. Use the command-line interface to issue commands to control the compute node power, view system information, and identify the compute node. You can also save one or more commands as a text file and run the file as a script.

For more information about the command-line interface, see [http://publib.boulder.ibm.com/infocenter/systemx/documentation/topic/com.lenovo.sysx.imm2.doc/printable\\_doc.html](http://publib.boulder.ibm.com/infocenter/systemx/documentation/topic/com.lenovo.sysx.imm2.doc/printable_doc.html).

- **Serial over LAN**

Establish a Serial over LAN (SOL) connection to manage compute nodes from a remote location. You can remotely view and change the UEFI settings, restart the compute node, identify the compute node, and perform other management functions. Any standard Telnet client application can access the SOL connection.

See your operating-system documentation for information about SOL commands that you can enter by using the command-line interface.

- **Web interface**

Use the secure IMM2 web interface to perform systems-management activities within a web browser. For information about accessing the web interface, see “Logging in to the web interface” on page 44.

### Viewing the network access tag

Use this information to locate the IP address by viewing the network access tag, or by using the Setup utility or systems-management software.

To access the web interface, you need the IP address of the IMM2. You can locate the IP address by viewing the network access tag. The network access tag is attached to the front of the compute node. The front of the network access tag lists the first four IMM MAC addresses in the lower-right corner, as shown in the following illustration.

## Front

**IMM Network Access**

**IPv4:** The default IMM hostname is "IMM2-" + the last 12 characters of the MAC address.

Secure connection required.  
(e.g., SSH, https://, etc.)

Place IMM MAC1  
Label Here

The rear of the network access tag lists the IPv6 link local address (LLA), as shown in the following illustration.

## Rear

Place LLA Label Here

**IPv6:** Link Local Address (LLA).



\* P 8 1 Y 4 3 8 4 \*

*Remove this tag prior to turning the system on.  
Save for future use.*

The MAC address is also available through the Setup utility, the CMM **cinstatus** command, and the CMM web interface.

- For more information about the Setup utility, see “Using the Setup utility” on page 26.
- For more information about the CMM **cinstatus** command, see the .
- From the CMM web interface, select **Compute Nodes** from the Chassis Management menu. For more information, see the . All fields and options are described in the CMM web interface online help.

**Note:** If the network access tag is missing from the front of the compute node, you can also locate the MAC address on a label located on the bottom of the compute node.

## Logging in to the web interface

Use these instruction to log in to the IMM2 web interface.

### Notes:

- If you are logging on to the IMM2 for the first time after installation, the IMM2 defaults to Dynamic Host Configuration Protocol (DHCP). If a DHCP host is not available, the IMM2 assigns a static IP address between 192.168.70.101 and 192.168.70.114, depending on the bay in which the compute node is installed.
- You can also assign IP addresses through the CMM **ifconfig** command. For more information about the CMM **ifconfig** command, see the .
- To assign IP addresses from the CMM web interface, click **Mgt Module Management → Network → Ethernet**.
- If the CMM and compute nodes are set to use DHCP, and the CMM loses connectivity to the network, the CMM attempts to acquire a new IP address when network connectivity is restored. The compute nodes will not attempt to acquire an IP address again and the compute node continues to use their existing IP addresses. Therefore, if you experience network problems on compute nodes after connectivity between the CMM and the network has been restored, you might need to reset the system-management processor on each of the compute nodes in the chassis (including Flex System Manager management software, if it is installed).



- The IMM2 user name and password are provisioned through the CMM. To use tools such as Advanced Settings Utility (ASU) for out-of-band communications, you must define local user accounts from the IMM web interface. To define local user accounts from the IMM web interface, click **IMM Management → Users**. The local user accounts are valid only for accessing the IMM web interface on this compute node. However, if you back up the IMM configuration, that backup will not contain the local user accounts that were created from the IMM user interface.
- The IMM2 logs you out of the web interface if your browser is inactive for the number of minutes that you have specified for the timeout period. To modify the timeout period, from the IMM web interface, click **IMM Management > User > Global Login Settings > General**.
  1. Open a web browser and in the **Address** or **URL** field, type the IP address or host name of the IMM2 to which you want to connect.
  2. On the Login page, type the CMM user name and CMM password. You are then directed to the main page of the IMM2 web interface. If you are using the IMM2 for the first time, you can obtain the user name and password from your system administrator. All login attempts are documented in the IMM event log.

## IMM2 action descriptions

Navigate to activities you perform with the IMM at the top of the IMM window. The title bar identifies the user name that is logged in, allows you to configure **Settings** for the status screen refresh rate and a custom trespass message, and **Log out** of the IMM web interface. Beneath the title bar are tabs that allow you to access various IMM2 functions, as listed in Table 2 “IMM2 actions” on page 45.

For more information about the IMM2 actions, see [http://publib.boulder.ibm.com/infocenter/systemx/documentation/topic/com.lenovo.sysx.imm2.doc/printable\\_doc.html](http://publib.boulder.ibm.com/infocenter/systemx/documentation/topic/com.lenovo.sysx.imm2.doc/printable_doc.html)

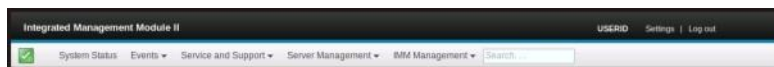

Table 2. IMM2 actions

| Tab                 | Selection             | Description   |
|---------------------|-----------------------|---|
| System Status       |                       | The System Status page allows you to view system status, active system events, and hardware health information. It provides quick links to the Server Power Actions, and Remote Control functions of the Server Management tab, and allows you to view an image of the last operating-system-failure screen capture.  |
| Events              | Event Log             | The Event Log page displays entries that are currently stored in the IMM event log. The log includes a text description of system events that are reported, including information about all remote access attempts and configuration changes. All events in the log are time stamped, using the IMM2 date and time settings. Some events also generate alerts, if they are configured to do so. You can sort and filter events in the event log and export them to a text file. |
|                     | Event Recipients      | The Event Recipients page allows you to manage who will be notified of system events. It allows you to configure each recipient, and manage settings that apply to all event recipients. You can also generate a test event to verify notification feature operation.   |
| Service and Support | Download Service Data | The Download Service Data page creates a compressed file of information that can be used by Support to assist you.  |
| Server Management   | Server Firmware       | The Server Firmware page displays firmware levels and allows you to update the IMM2 firmware, compute node firmware, and DSA firmware.  |

Table 2. IMM2 actions (continued)

| Tab               | Selection                | Description   |
|-------------------|--------------------------|---|
|                   | Remote Control           | The Remote Control page allows you to control the compute node at the operating system level. It provides access to both Remote Disk and Remote Console functionality. You can view and operate the compute node console from your computer, and you can mount one of your computer disk drives, such as the CD-ROM drive or the diskette drive, on the compute node. When you have mounted a disk, you can use it to restart the compute node and to update firmware on the compute node. The mounted disk appears as a USB disk drive that is attached to the compute node.   |
|                   | Server Properties        | The Server Properties page provides access to various properties, status, and settings for your compute node: <ul style="list-style-type: none"> <li>• The General Settings tab displays information that identifies the system to operations and support personnel.</li> <li>• The LEDs tab displays the status of all system LEDs. It also allows you to change the state of the location LED.</li> <li>• The Hardware Information tab displays compute node vital product data (VPD). The IMM2 collects compute node information, compute node component information, and network hardware information.</li> <li>• The Environmentals tab displays voltage and temperature information for the compute node and its components.</li> <li>• The Hardware Activity tab displays a history of Field Replacable Unit (FRU) components that have been added to or removed from the system.</li> </ul> |
|                   | Server Power Actions     | The Server Power Actions page provides full remote power control over your compute node with power-on, power-off, and restart actions.  |
|                   | Disks                    | The Disks page displays the status of hard disk drives in the system. You can click on a drive name to display active events for the hard disk drive.   |
| Server Management | Processors               | The Processors page displays the microprocessors in the system, along with their status and rated speed. You can click on a microprocessor name to display events and additional hardware information for the microprocessor.   |
|                   | Server Timeouts          | The Server Timeouts page allows you to manage compute node start timeouts to detect and recover from compute node hang occurrences.   |
|                   | PXE Network Boot         | The PXE Network Boot page allows you to change the host compute node startup (boot) sequence for the next restart to attempt a Preboot Execution Environment (PXE)/Dynamic Host Configuration Protocol (DHCP) network startup. The host startup sequence will be altered only if the host is not under Privileged Access Protection (PAP).  |
|                   | Latest OS Failure Screen | The Latest OS Failure Screen page displays a screen image, when available, of the most recent operating system failure on the compute node. For your IMM to capture operating system failure screens, the operating system watchdog must be enabled.  |

Table 2. IMM2 actions (continued)

| Tab            | Selection      | Description  |
|----------------|----------------|--|
| IMM Management | IMM Properties | <p>The IMM Properties page provides access to various properties, status, and settings for your IMM2:</p> <ul style="list-style-type: none"> <li>• The Firmware tab provides a link to the Server Firmware section of Server Management.</li> <li>• The IMM Date and Time Settings tab allows you to view and configure date and time settings for the IMM2.</li> <li>• The Serial Port tab configures the IMM2 serial port settings. These settings include the serial port baud rate used by the serial port redirection function and the key sequence to switch between the serial redirection and command-line interface (CLI) modes.</li> </ul>   |
|                | Users          | <p>The Users page allows you to configure the IMM2 login profiles and global login settings, and to view users that are currently logged in to the IMM2. Global login settings include enabling Lightweight Directory Access Protocol (LDAP) compute node authentication, setting the web inactivity timeout, and customizing the account security settings.</p> <p><b>Note:</b> Some things cannot be done (e.g. cannot create users) if the CMM is managing IPMI/SNMPv3 user account.</p>  |
|                | Network        | <p>The Network Protocol Properties page provides access to networking properties, status, and settings for your IMM2:</p> <ul style="list-style-type: none"> <li>• The Ethernet tab manages how the IMM2 communicates using Ethernet.</li> <li>• The SNMP tab configures the SNMPv1 and SNMPv3 agents.</li> <li>• The DNS tab displays the DNS servers that the IMM2 interacts with.</li> <li>• The DDNS tab enables or disables and configures Dynamic DNS for the IMM2.</li> <li>• The SMTP tab configures SMTP compute node information used for alerts sent via email.</li> <li>• The LDAP tab configures user authentication for use with one or more LDAP compute nodes.</li> <li>• The Telnet tab manages Telnet access to the IMM2.</li> <li>• The USB tab controls the USB interface used for in-band communication between the compute node and the IMM2. These settings do not affect the USB remote control functions (keyboard, mouse, and mass storage).</li> <li>• The Port Assignments tab allows you to change the port numbers used by some services on the IMM2.</li> </ul> |
| IMM Management | Security       | <p>The IMM Security page provides access to security properties, status, and settings for your IMM2:</p> <ul style="list-style-type: none"> <li>• The HTTPS Server tab allows you to enable or disable the HTTPS compute node and manage its certificates.</li> <li>• The CIM Over HTTPS tab allows you to enable or disable CIM over HTTPS and manage its certificates.</li> <li>• The LDAP Client tab allows you to enable or disable LDAP security and manage its certificates.</li> <li>• The SSH Server tab allows you to enable or disable the SSH compute node and manage its certificates.</li> </ul>  |

Table 2. IMM2 actions (continued)

| Tab | Selection                        | Description   |
|-----|----------------------------------|---|
|     | IMM Configuration                | <p>The IMM Configuration page displays a summary of the current IMM2 configuration settings. It also provides the following functions:</p> <ul style="list-style-type: none"> <li>• Backup the current IMM2 configuration</li> <li>• Restore a saved IMM2 configuration</li> <li>• Display backup and restoration status</li> <li>• Reset the configuration of the IMM2 to the factory defaults.</li> <li>• Access the IMM2 initial setup wizard</li> </ul> <p><b>Note:</b> Backups that you make from the IMM user interface will not contain any local user accounts that were created from the IMM user interface.</p> |
|     | Restart IMM                      | The Restart IMM page allows you to reset the IMM.   |
|     | Reset IMM to factory defaults... | <p>The Reset IMM to factory defaults... page allows you to reset the configuration of the IMM2 to the factory defaults.</p> <p><b>Attention:</b> When you click <b>Reset IMM to factory defaults...</b>, all of the modifications that you made to the IMM2 are lost.</p>   |
|     | Activation Key Management        | The Activation Key Management page allows you to manage activation keys for optional IMM2 or compute node Features on Demand (FoD) features.  |

## Accessing the IMM2 using the LAN over USB interface

Unlike a baseboard management controller, the IMM2 does not require IPMI device drivers or USB daemons for in-band IMM2 communication. Instead, a LAN over USB interface enables in-band communication to the IMM2; the IMM2 hardware on the system board presents an internal Ethernet interface from the IMM2 to the operating system. LAN over USB is also called the *USB in-band interface* in the IMM2 web interface.

The following table shows the IP addresses for the IMM2 and the host.

Table 3. LAN over USB addresses

| IMM2 IP address | IMM2 IP subnet mask | Host address   | Host subnet     | Host subnet mask | Keyboard Controller Style (KCS) address |
|-----------------|---------------------|----------------|-----------------|------------------|---|
| 169.254.95.118  | 255.255.255.0       | 169.254.95.120 | 169.254.95.0/24 | 255.255.255.0    | 0x8C80                                  |

## Potential conflicts with the LAN over USB interface

In some situations, the LAN over USB interface can conflict with certain network configurations, applications, or both. For example, Open MPI attempts to use all the available network interfaces on a server or compute node. Open MPI detects the IMM2 LAN over USB interface and attempts to use it to communicate with other systems in a clustered environment. The LAN over USB interface is an internal interface, so this interface does not work for external communication with other systems in the cluster.

## Resolving conflicts with the IMM2 LAN over USB interface

Use any of the following actions to resolve LAN over USB conflicts with network configurations and applications.

Use one of the following methods to resolve LAN over USB conflicts.

**Note:** For conflicts with Open MPI, configure the application so that it does not attempt to use this interface.

- Take down the interface (run **ifdown** under Linux).
- Remove the device driver (run **rmmod** under Linux).
- Disable the LAN over USB interface from the CMM web interface.

**Note:** You cannot update the firmware for a compute node while the LAN over USB interface is disabled. Before updating the firmware, you must re-enable the interface. After updating the firmware, you can disable the interface again.

To disable the LAN over USB interface from the CMM web interface, complete the following steps.

1. Log in to the CMM web interface.
2. From the CMM web interface homepage click **Chassis Management → Compute Nodes**.
3. Click the compute node ID.
4. Click the **General** tab.
5. Uncheck **Enable Ethernet Over USB** to disable the LAN over USB interface.

## Configuring the LAN over USB interface

An IMM2 must be configured to use the LAN over USB interface. The firmware update package or Advanced Settings Utility attempts to perform the setup automatically, if needed. If the automatic setup fails or if you prefer to set up the LAN over USB manually, use one of the following processes.

For more information about LAN over USB configuration on different operating systems, see <http://www.ibm.com/support/entry/portal/docdisplay?Indocid=MIGR-5083207>.

### Installing the LAN over USB Windows device driver

When you install a Windows operating system, there will be an unknown RNDIS device in the Device Manager. Lenovo provides a Windows INF file that identifies this device. The signed version of the INF file is included in all of the Windows versions of the IMM2, UEFI, and DSA update packages. Complete the following steps to install `ibm_rndis_server_os.inf`.

To install the LAN over USB device driver for Windows, complete the following steps.

**Note:** You only have to perform these steps if the compute node is running a Windows operating system and the `ibm_rndis_server_os.inf` file has not been previously installed. The file only has to be installed once. It is required by Windows operating systems to detect and use the LAN over USB functionality.

Step 1. Obtain a Windows version of the server or compute node UEFI code package (see “Updating firmware and device drivers” on page 23 for more information).

Step 2. Extract the `ibm_rndis_server_os.inf` and `device.cat` files from the firmware update package and copy them to the `\WINDOWS\inf` subdirectory.

**Note:** You can use the `-x path` command-line interface option to extract the files. For more information about this option, see the readme file that comes with the update package.

Step 3. (Windows 2003) Install the `ibm_rndis_server_os.inf` file by right-clicking the file and clicking **Install**. This generates a PNF file of the same name in `\WINDOWS\inf`.

(Windows 2008) Click **Computer Management → Device Manager** and find the RNDIS Device. Click **Properties → Driver → Reinstall driver**. Point the server or compute node to the `\Windows\inf` directory where it can find the `ibm_rndis_server_os.inf` file and install the device.

Step 4. Click **Computer Management → Device Manager**. Right-click **Network adapters** and select **Scan for hardware changes**. A small pop-up confirms that the Ethernet device is found and installed. The New Hardware Wizard starts automatically.

- Step 5. When you are prompted Can Windows connect to Windows Update to search for software?, select **No, not this time**. Click **Next** to continue.
- Step 6. When you are prompted What do you want the wizard to do?, select **Install from a list or specific location (Advanced)**. Click **Next** to continue.
- Step 7. When you are prompted Please choose your search and installation options, select **Don't search. I will choose the driver to install**. Click **Next** to continue.
- Step 8. When you are prompted Select a hardware type, and then click Next, select **Network adapters**. Click **Next** to continue.
- Step 9. When you are prompted with the statement Completing the Found New Hardware Wizard, click **Finish**. A new local area connection appears. If the message This connection has limited or no connectivity is displayed, ignore this message.
- Step 10. Return to the Device Manager. **IBM USB Remote NDIS Network Device** or **Lenovo USB Remote NDIS Network Device** appears under **Network Adapters**.
- Step 11. Use the Setup utility to view or set the IP address. See Table 3 “LAN over USB addresses” on page 48 for information about the IP addresses.
  - a. Connect a keyboard, monitor, and mouse to the console breakout cable and connect the console breakout cable to the compute node.
  - b. Turn on the compute node (see “Turning on the compute node” on page 16).
  - c. When the prompt Press <F1> Setup is displayed, press F1. If you have set an administrator password, you must type the administrator password to access the full Setup utility menu. If you do not type the administrator password, a limited Setup utility menu is available.
  - d. Select **System Settings** → **Integrated Management Module** → **Network Configuration**.
  - e. Locate the IP address.
  - f. Exit from the Setup utility.

## Installing the LAN over USB Linux device driver

Versions of Linux since RHEL5 Update 3 and SLES10 Service Pack 2 support the LAN over USB interface by default. This interface is detected and displayed during the installation of these operating systems.

See Table 3 “LAN over USB addresses” on page 48 for information about the IP addresses.

**Note:** Older Linux distributions might not detect the LAN over USB interface and might require manual configuration. For information about configuring LAN over USB on specific Linux distributions, see <http://www.ibm.com/support/entry/portal/docdisplay?Indocid=MIGR-5083207>.

The IMM2 LAN over USB interface requires that the `usbnet` and `cdc_ether` device drivers be loaded. If the drivers have not been installed, use `modprobe` to install them. When these drivers are installed, the IMM2 USB network interface is shown as a network device in the operating system. To discover the name that the operating system has assigned to the IMM2 USB network interface, type

```
dmesg | grep -i cdc ether
```

---

## Chapter 5. Parts listing, Types 7167 and 2590

The following replaceable components are available for the Lenovo Flex System x440 Compute Node Types 7167 and 2590.

For an updated parts listing on the web, go to <http://www.lenovo.com/support>.

**Note:** The illustrations in this document might differ slightly from your hardware.

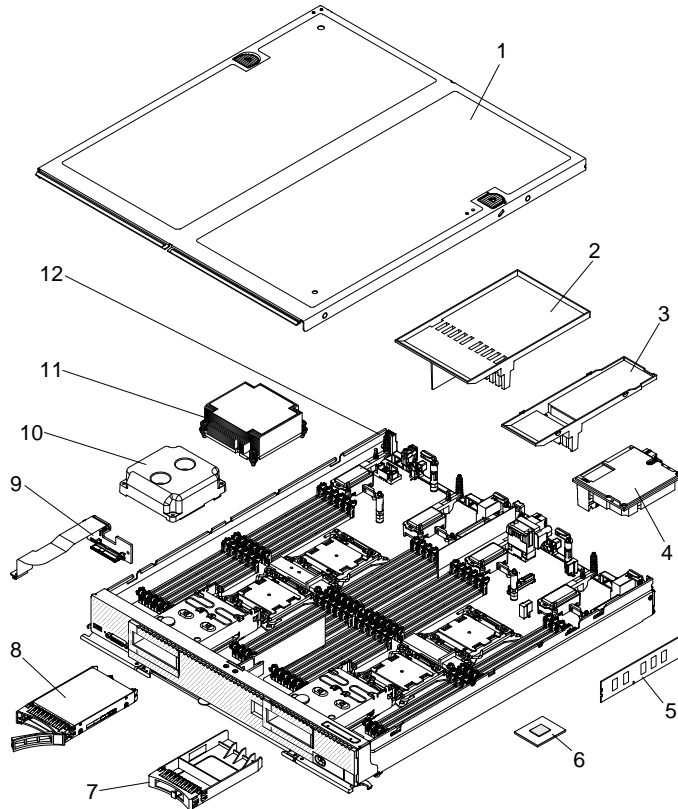

Replaceable components consist of consumable parts, structural parts, and customer replaceable units (CRUs):

- **Consumable parts:** Purchase and replacement of consumable parts (components, such as batteries and printer cartridges, that have depletable life) is your responsibility. If Lenovo acquires or installs a consumable part at your request, you will be charged for the installation.
- **Structural parts:** Purchase and replacement of structural parts (components such as the top cover and bezel) is your responsibility. If Lenovo acquires or installs a structural part at your request, you will be charged for the installation.
- **Tier 1 customer replaceable unit (CRU):** Replacement of Tier 1 CRUs is your responsibility. If Lenovo installs a Tier 1 CRU at your request without a service contract, you will be charged for the installation.
- **Tier 2 customer replaceable unit:** You may install a Tier 2 CRU yourself or request Lenovo to install it, at no additional charge, under the type of warranty service that is designated for your compute node. Tier 2 CRUs should be installed only by trained service technicians.

For information about the terms of the warranty and getting service and assistance, see the *Warranty Information* document.

Table 4. Parts listing, Types 7167 and 2590

| Index | Description   | CRU part number (Tier 1) | CRU part number (Tier 2) |
|-------|---|--------------------------|--------------------------|
| 1     | Top cover (see "Consumable parts")  |                          |                          |
| 2     | Center Air baffle   | 00D6314                  |                          |
| 3     | Air baffle above DIMMs (see "Consumable parts")   |                          |                          |
| 4     | Flex System CN4054R 4 port 10 Gb Virtual Fabric Adapter   | 00MN789                  |                          |
| 4     | Flex System EN2024 4-Port 1 Gb Ethernet Adapter   | 49Y7902                  |                          |
| 4     | Flex System EN4172 2-Port 16 Gb Ethernet Adapter  | 00AG532                  |                          |
| 4     | Flex System FC3052 2-Port 8 Gb FC Adapter   | 00MN779                  |                          |
| 4     | Flex System FC3172 2-Port 8 Gb FC Adapter   | 69Y1941                  |                          |
| 4     | Flex System FC5054 4-Port 16 Gb FC Adapter  | 95Y2394                  |                          |
| 4     | Flex System FC5172 2-Port 16 Gb FC Adapter  | 69Y1945                  |                          |
| 4     | Flex System CN4052 2-Port 10Gb Virtual Fabric Adapter   | 00JY803                  |                          |
| 4     | Flex System CN4052S 2-Port 10Gb Virtual Fabric Adapter  | 00AG543                  |                          |
| 4     | Flex System CN4054S 4-Port 10Gb Virtual Fabric Adapter  | 00AG593                  |                          |
| 4     | Flex System CN4052S 2-Port 10Gb Virtual Fabric Adapter w/FCoE   | 01CV783                  |                          |
| 4     | Flex System CN4054S 4port10Gb VirtualFabricAdapter w/FCoE   | 01CV793                  |                          |
| 4     | ServeRAID-M5115 SAS/SATA RAID Controller  | 00D5073                  |                          |
| 5     | Memory, 8 GB 1R x 4 4 Gbit DDR-3 1600 MHz 1.35V LP RDIMM  | 00D5038                  |                          |
| 5     | Memory, 32 GB 4R x 4 4 Gbit DDR-3 1866 MHz 1.5V LP LR-DIMM  | 46W0763                  |                          |
| 6     | Intel Xeon Processor E5-4607V2 6C 2.6 GHz 15 MB Cache 1333 MHz 95W (Type 7167, models G2A, G2B, G2C, G2G, G2J, G2K, G2M, G2U, G2V and Type 2590 model G2X)                      |                          | 00D1954                  |
| 6     | Intel Xeon Processor E5-4610V2 8C 2.3 GHz 16 MB Cache 1600 MHz 95W (Type 7167, models H2A, H2B, H2C, H2G, H2J, H2K, H2M, H2U, H2V)  |                          | 00D1959                  |
| 6     | Intel Xeon Processor E5-4620V2 8C 2.2 GHz 20 MB Cache 1600 MHz 95W (Type 7167, models J2A, J2B, J2C, J2G, J2J, J2K, J2M, J2U, J2V, J4A, J4B, J4C, J4G, J4J, J4K, J4M, J4U, J4V) |                          | 00D1964                  |
| 6     | Intel Xeon Processor E5-4627V2 8C 3.3 GHz 16 MB Cache 1866 MHz 130W (Type 7167 configure-to-order models)   |                          | 00D1979                  |
| 6     | Intel Xeon Processor E5-4650V2 10C 2.4 GHz 25 MB Cache 1866 MHz 95W (Type 7167, models L2A, L2B, L2C, L2G, L2J, L2K, L2M, L2U, L2V)   |                          | 00D1974                  |
| 6     | Intel Xeon Processor E5-4657LV2 12C 2.4 GHz 30 MB Cache 1866 MHz 115W (Type 7167, models M2A, M2B, M2C, M2G, M2J, M2K, M2M, M2U, M2V)   |                          | 00D1989                  |
| 7     | Filler, 2.5 inch hard disk drive bay (see "Consumable parts")   |                          |                          |
| 8     | Hard disk drive, SAS 2.5 inch 300 GB 15K 6 Gbps slim hot-swap   | 81Y9671                  |                          |
| 8     | Hard disk drive, SAS 2.5 inch 300 GB 10K 6 Gbps SFF G2 hot-swap   | 90Y8878                  |                          |



Table 4. Parts listing, Types 7167 and 2590 (continued)

| Index | Description   | CRU part number (Tier 1) | CRU part number (Tier 2) |
|-------|---|--------------------------|--------------------------|
| 8     | Hard disk drive, SAS 2.5 inch 500 GB 7.2K NL 6 Gbps G2 hot-swap       | 90Y8954                  |                          |
| 8     | Hard disk drive, SAS 2.5 inch 600 GB 10K 6 Gbps SFF G2 hot-swap       | 90Y8873                  |                          |
| 8     | Hard disk drive, SAS 2.5 inch 600 GB, 15K, 6 Gbps G2HS hot-swap       | 00AJ301                  |                          |
| 8     | Hard disk drive, SAS 2.5 inch 900 GB 10K 6 Gbps slim hot-swap         | 81Y9651                  |                          |
| 8     | Hard disk drive, SAS 2.5 inch 1.2 TB, 10K, 6 Gbps G2HS hot-swap       | 00AD076                  |                          |
| 8     | Self encrypting drive, SAS 2.5 inch 300 GB 10K 6 Gbps SFF G2HS        | 90Y8914                  |                          |
| 8     | Self encrypting drive, SAS 2.5 inch 600 GB 10K 6 Gbps SFF G2HS        | 90Y8909                  |                          |
| 8     | Self encrypting drive, SAS 2.5 inch 900 GB 10K 6 Gbps SFF G2HS        | 81Y9663                  |                          |
| 8     | Self encrypting drive, SAS 2.5 inch 1.2 TB 10K 6 Gbps G2HS            | 00AD087                  |                          |
| 8     | Solid state drive, SATA 1.8 inch 120 GB hot-swap MLC Enterprise Value | 00AJ336                  |                          |
| 8     | Solid state drive, SATA 1.8 inch 240 GB hot-swap MLC Enterprise Value | 00AJ341                  |                          |
| 8     | Solid state drive, SATA 1.8 inch 480 GB hot-swap MLC Enterprise Value | 00AJ346                  |                          |
| 8     | Solid state drive, SATA 1.8 inch 800 GB hot-swap MLC Enterprise Value | 00AJ351                  |                          |
| 8     | Solid state drive, SAS 2.5 inch 200 GB MLC HS Enterprise              | 49Y6130                  |                          |
| 8     | Solid state drive, SAS 2.5 inch 400 GB MLC HS Enterprise              | 49Y6135                  |                          |
| 8     | Solid state drive, SAS 2.5 inch 800 GB MLC HS Enterprise              | 49Y6140                  |                          |
| 8     | Solid state drive, SAS 2.5 inch 1.6 TB MLC HS Enterprise              | 49Y6196                  |                          |
| 8     | Solid state drive, SATA 2.5 inch 120 GB MLC Enterprise Value          | 00AJ356                  |                          |
| 8     | Solid state drive, SATA 2.5 inch 240 GB hot-swap MLC Enterprise Value | 00AJ361                  |                          |
| 8     | Solid state drive, SATA 2.5 inch 480 GB hot-swap MLC Enterprise Value | 00AJ366                  |                          |
| 8     | Solid state drive, SATA 2.5 inch 800 GB hot-swap MLC Enterprise Value | 00AJ371                  |                          |
| 8     | Solid state drive, S3500 SATA 2.5 inch 80 GB MLC Enterprise Value     | 00AJ041                  |                          |
| 8     | Solid state drive, S3500 SATA 2.5 inch 120 GB MLC HS Enterprise Value | 00AJ001                  |                          |
| 8     | Solid state drive, S3500 SATA 2.5 inch 240 GB MLC HS Enterprise Value | 00AJ006                  |                          |
| 8     | Solid state drive, S3500 SATA 2.5 inch 240 GB MLC Enterprise Value    | 00AJ046                  |                          |
| 8     | Solid state drive, S3500 SATA 2.5 inch 400 GB MLC Enterprise Value    | 00AJ051                  |                          |
| 8     | Solid state drive, S3500 SATA 2.5 inch 480 GB MLC HS Enterprise Value | 00AJ011                  |                          |
| 8     | Solid state drive, S3500 SATA 2.5 inch 800 GB MLC Enterprise Value    | 00AJ456                  |                          |
| 8     | Solid state drive, S3500 SATA 2.5 inch 800 GB MLC HS Enterprise Value | 00AJ016                  |                          |
| 8     | Solid state drive, S3500 SATA 2.5 inch 1.6 TB MLC HS Enterprise Value | 00FM269                  |                          |
| 8     | Solid state drive, S3700 1.8 inch 200 GB MLC Enterprise               | 41Y8367                  |                          |
| 8     | Solid state drive, S3700 1.8 inch 400 GB MLC Enterprise               | 41Y8372                  |                          |

Table 4. Parts listing, Types 7167 and 2590 (continued)

| Index | Description   | CRU part number (Tier 1) | CRU part number (Tier 2) |
|-------|---|--------------------------|--------------------------|
| 8     | Solid state drive, S3700 SATA 2.5 inch 200 GB MLC HS Enterprise                                 | 41Y8332                  |                          |
| 8     | Solid state drive, S3700 SATA 2.5 inch 400 GB MLC HS Enterprise                                 | 41Y8337                  |                          |
| 8     | Solid state drive, S3700 SATA 2.5 inch 800 GB MLC HS Enterprise                                 | 41Y8342                  |                          |
| 9     | Cable assembly, SAS   | 00D6327                  |                          |
| 10    | Filler, microprocessor socket (see "Consumable parts")  |                          |                          |
| 11    | Heat sink, front microprocessor   |                          | 00D6315                  |
| 11    | Heat sink, rear microprocessor  |                          | 00D6316                  |
| 12    | Base assembly (includes chassis and system board) without LOM (Types 7167 and 2590, all models) |                          | 00MN618                  |
|       | 2 GB USB Memory Key   | 42D0545                  |                          |
|       | Adapter connector retention kit   | 46M2827                  |                          |
|       | Alcohol wipes   |                          | 00MP352                  |
|       | Alcohol wipes   |                          | 59P4739                  |
|       | Bezel, front assembly   | 00D6383                  |                          |
|       | Hard disk drive backplane, SAS single 2.5 inch  | 00MN645                  |                          |
|       | Flex System console breakout cable (models AC1, MC1, CTO)                                       | 81Y5287                  |                          |
|       | Label kit   | 00D6313                  |                          |
|       | Light path LED card   | 81Y5290                  |                          |
|       | Microprocessor installation tool  |                          | 94Y9960                  |
|       | Miscellaneous parts kit   |                          | 46M2832                  |
|       | RFID label tag assembly - EMEA  | 00E6323                  |                          |
|       | RFID label tag assembly - US  | 74Y8800                  |                          |
|       | ServeRAID-M5100 Series 1 x 2.5 inch SAS backplane   | 44E4763                  |                          |
|       | ServeRAID-M5100 Series flex cable assembly  | 00D5089                  |                          |
|       | ServeRAID-M5100 Series solid state drive flex expansion cable                                   | 00D5078                  |                          |
|       | ServeRAID-M5100 Series super capacitor  | 81Y4579                  |                          |
|       | ServeRAID-M5100 Series super capacitor power cable  | 44E4767                  |                          |
|       | ServeRAID-M5100 Series 2 x 1.8 inch SAS backplane   | 44E4765                  |                          |
|       | Flex System Flash Kit V2 backplane card assembly  | 47C8844                  |                          |
|       | Flex System Flash Kit V2 flex cable   | 00FE024                  |                          |
|       | Thermal grease kit  |                          | 41Y9292                  |

## Consumable parts

Consumable parts are not covered by the Statement of Limited Warranty. The following consumable parts are available for purchase from the retail store.

Table 5. Consumable parts

| Index | Description  | Consumable part number |
|-------|--|------------------------|
| 1     | Top cover (when ordering this part, order the Label kit (part number 00D6313)) | 46M2830                |
| 3     | Air baffle above DIMMs   | 81Y5177                |
| 7     | SSD filler bezel, 2.5 inch hard disk drive bay                                 | 44T2248                |
| 10    | Filler, microprocessor socket  | 00D6325                |
|       | CMOS battery, 3.0 volt (all models)  | 33F8354                |
|       | Cam handle kit   | 46M2828                |
|       | Hard disk drive cage, SAS  | 46M2829                |
|       | Rear bulkhead assembly full wide   | 46M2833                |
|       | ServeRAID-M5100 Series left-side air baffle                                    | 00D5080                |
|       | ServeRAID-M5100 Series center air baffle                                       | 46C9933                |
|       | ServeRAID-M5100 Series bezel assembly  | 46C9935                |

To order a consumable part, complete the following steps:

1. Go to <http://www.ibm.com>.
2. From the **Products** menu, select **Upgrades, accessories & parts**.
3. Click **Obtain maintenance parts**; then, follow the instructions to order the part from the retail store.

If you need help with your order, call the toll-free number that is listed on the retail parts page, or contact your local representative for assistance.



---

## Chapter 6. Troubleshooting

Use this information to diagnose and correct problems that might occur in your x440 Compute Node Types 7167 and 2590.

The information in this section describes tools and procedures for solving hardware and software problems. If you cannot diagnose and correct a problem by using the information, see Appendix A “Getting help and technical assistance” on page 893 for more information.

---

### Service bulletins

IBM continually updates the support website with tips and techniques that you can use to solve problems that you might have with the x440 Compute Node Types 7167 and 2590.

To find service bulletins that are available for the x440 Compute Node Types 7167 and 2590, go to <http://www.lenovo.com/support> and search for the terms 7167 or 2590 and retain.

---

### Diagnostic tools

Use this information to review the diagnostic tools to diagnose and solve hardware-related problems.

### Light path diagnostics

Use this information as an overview of light path diagnostics.

Light path diagnostics is a system of LEDs above the control panel and on various internal components of the compute node. When an error occurs, LEDs can be lit throughout the compute node to help identify the source of the error.

### Viewing the light path diagnostics LEDs

Use this information to locate and identify the light path diagnostics LEDs.

Before you work inside the compute node to view light path diagnostics LEDs, read “Safety” on page iii and “Installation guidelines” on page 827.

If an error occurs, view the light path diagnostics LEDs in the following order:

1. Look at the control panel on the front of the compute node.

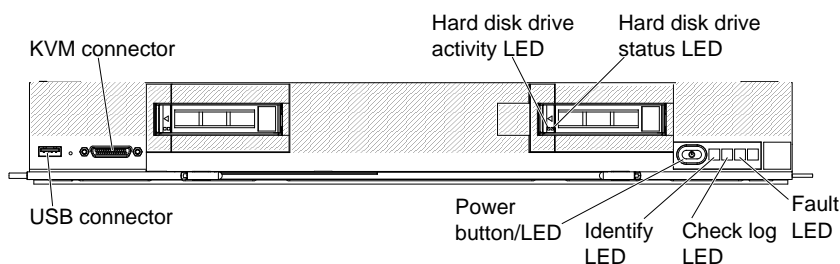

- If the check log LED is lit, it indicates that an Automatic BIOS Recovery has occurred. The compute node will start by using the backup UEFI image.
- If the fault LED is lit, it indicates that an error has occurred; view the light path diagnostics panel and LEDs to isolate the failing component.

2. To view the light path diagnostics LEDs, select one of the following procedures:

- You can view the LEDs through the CMM **led** command, the CMM web interface, the Lenovo XClarity Administrator (if available), or the Flex System Manager management software (if available).
  - For more information about the CMM **led** command, see the .
  - From the CMM web interface, select **Blade Servers** from the **Chassis Management** menu. All fields and options are described in the CMM web interface online help.
  - For more information about the Lenovo XClarity Administrator, see <https://support.lenovo.com/us/en/documents/LNVO-XCLARIT>.
  - For more information about the Flex System Manager management software, see .
- If you are in the same location as the compute node, you can complete the following steps:
  - a. Remove the compute node from the Flex System chassis, (see “Removing a compute node from a chassis” on page 828 for instructions).
  - b. Carefully lay the compute node on a flat, static-protective surface.
  - c. Open the compute node cover (see “Removing the compute node cover” on page 836 for instructions).
  - d. Remove the air baffles that are installed over the DIMM connectors.
  - e. Press the power button. When you press the power button, LEDs on the light path diagnostics panel and the system board will be lit if there are any hardware-related issues.

**Note:** The power source for light path diagnostics is designed to last only a short time. If you press the power button and the light path diagnostics LED lights, light path diagnostics is charged to light the LEDs.

The following illustration shows the LEDs on the light path diagnostics panel.

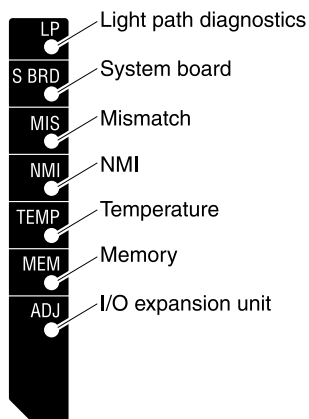

The following illustration shows the locations of the light path diagnostics LEDs on the system board.

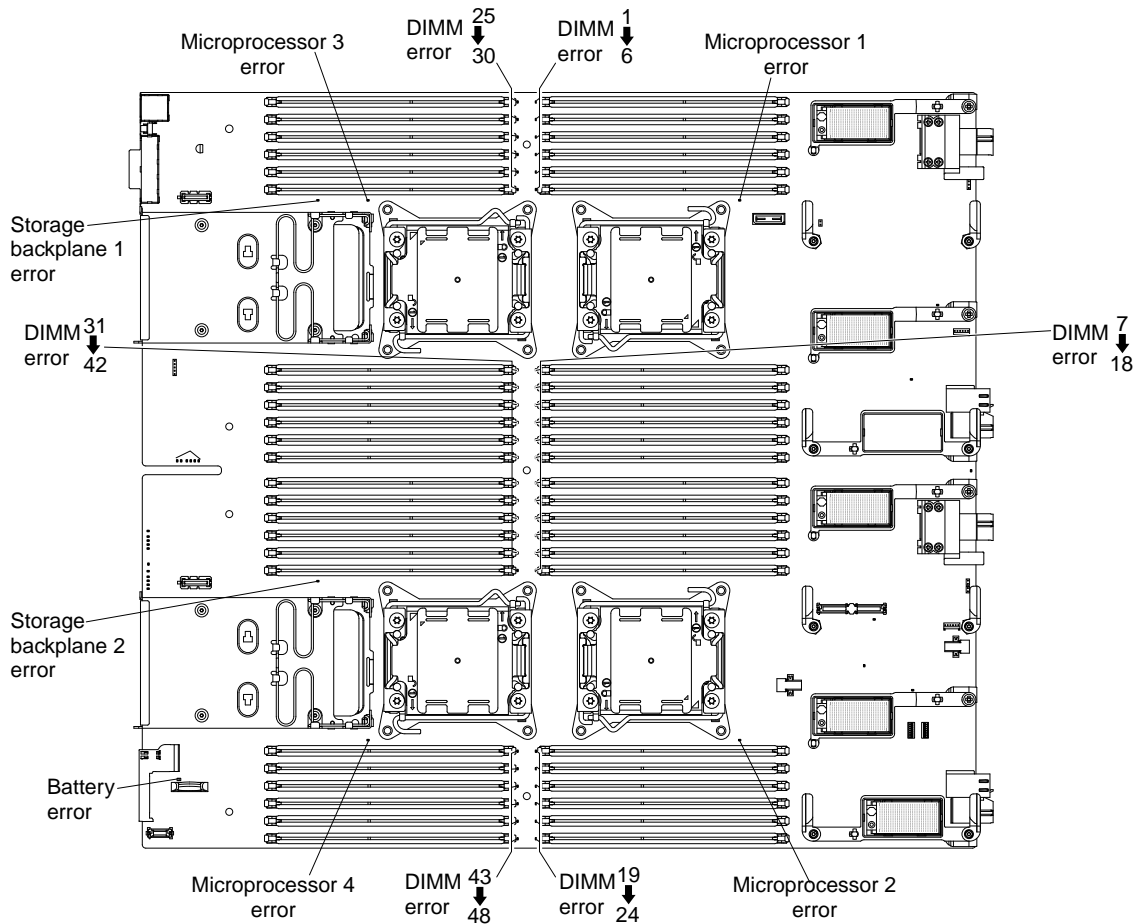

## Light path diagnostics LEDs

Use this information to diagnose possible errors that are indicated by the light path diagnostics LEDs.

The following table describes the LEDs on the light path diagnostics panel and the light path diagnostics LEDs on the system board. LEDs on the light path card are visible from the top of the compute node. See “Viewing the light path diagnostics LEDs” on page 57 for information about lighting the LEDs.

| Lit light path diagnostics LED | Description  |
|--------------------------------|--|
| Light path diagnostics         | This LED lights when the light path LED card is installed  |
| Memory                         | The IMM2 lights this LED, the corresponding DIMM error LEDs on the system board and the fault LED when a memory fault has occurred.                                      |
| Mismatch                       | The IMM2 lights this LED and the fault LED when a mismatch has occurred between the processors, DIMMs, or hard disk drives within the configuration as reported by POST. |
| NMI                            | The IMM2 lights this LED and the fault LED when a nonmaskable interrupt (NMI) occurs.  |
| Spare                          | Reserved for future use  |
| System board                   | The IMM2 lights this LED and the fault LED when a system board error has been detected.  |
| Temperature                    | The IMM lights this LED and the fault LED when an over-temperature condition has occurred that was critical enough to shut down the compute node.                        |

Table 6. Light path LED errors

| Light path diagnostics LED | Description  | Action   |
|----------------------------|--|--|
| None                       | An error has occurred and cannot be isolated, or the IMM2 has failed.                | Make sure that the light path diagnostics LED is lit to ensure that there is enough power in the compute node to light the rest of the LEDs.   |
| Battery error              | The battery failed.  | <ol style="list-style-type: none"> <li>1. Reseat the battery.</li> <li>2. Replace the battery.</li> <li>3. (Trained service technician only) Replace the base assembly.</li> </ol>   |
| DIMM x error               | A memory error occurred.   | <ol style="list-style-type: none"> <li>1. Make sure that the DIMM that is indicated by the lit LED is supported.</li> <li>2. Reseat the DIMM that is indicated by the lit LED.</li> <li>3. Replace the DIMM that is indicated by the lit LED (see "Removing a DIMM" on page 839, and "Installing a DIMM " on page 840)</li> </ol> <p><b>Note:</b> Multiple DIMM LEDs do not necessarily indicate multiple DIMM failures. If more than one DIMM LED is lit, reseat or replace one DIMM at a time until the error is corrected (see "Removing a DIMM" on page 839, and "Installing a DIMM " on page 840)</p> |
| Light path diagnostics LED | System board light path diagnostics LEDs have power.                                 | Check for error LEDs that are lit on the system board.   |
| Microprocessor x error     | The microprocessor has failed, or overheated, or the boot microprocessor is missing. | <ol style="list-style-type: none"> <li>1. Check the CMM log for more information. Perform the appropriate action.</li> <li>2. If the log shows that a microprocessor is disabled or that a microprocessor IERR has occurred, perform the appropriate action.</li> <li>3. (Trained service technician only) Reset the microprocessor that is indicated by the lit LED.</li> <li>4. (Trained service technician only) Replace the microprocessor that is indicated by the lit LED.</li> </ol>  |
| Microprocessor mismatch    | The microprocessors do not match.  | Make sure that all installed microprocessors are identical (number of cores, cache size, type, clock speed, and internal / external clock frequencies).  |



Table 6. Light path LED errors (continued)

| Light path diagnostics LED | Description   | Action  |
|----------------------------|---|---|
| NMI                        | The system board failed.                                | <ol style="list-style-type: none"> <li>1. Reinsert the compute node, and then restart the compute node. Check the IMM event log for information about the error.</li> <li>2. (Trained service technician only) Replace the base assembly.</li> </ol>            |
| System board               | The system board failed.                                | (Trained service technician only)<br>Replace the base assembly.   |
| Temperature                | The system temperature has exceeded the threshold level | <ol style="list-style-type: none"> <li>1. Check the function of the shared compute node and chassis unit resources.</li> <li>2. Make sure that the room temperature is not too high.</li> </ol>   |
| Hard disk drive            | A hard disk drive failed.                               | Run the fixed disk or attached disk diagnostic test. If the drive passes the test but continues to have a problem replace the hard disk drive (see “Removing a hot-swap hard disk drive” on page 856 and “Installing a hot-swap hard disk drive” on page 856).. |
| Adapter fault              | An adapter failed.                                      | Run the adapter card diagnostics test. If adapter passes the test but continues to have a problem, replace the adapter.   |

Table 7. System board diagnostic LED information

| LED         | Color  | LED name              | Description   |
|-------------|--------|-----------------------|---|
| D9001 D9004 | Green  | Checkpoint LEDs (MSD) | These LEDs represent checkpoint display codes in binary.  |
| D9005 D9008 | Green  | Checkpoint LEDs (LSD) | These LEDs represent checkpoint display codes in binary.  |
| D9009       | Green  | FPGA heartbeat        | This LED will light when there is activity on the FPGA.   |
| DVL01       | Yellow | Battery error         | The IMM2 lights this LED and the fault LED when the battery is defective.   |
| DBL01       | Yellow | IMM fault             | The IMM2 lights this LED and the fault LED when a problem has been detected with the IMM2.  |
| DPL00       | Yellow | CPU 1 error           | The IMM2 lights this LED and the fault LED when microprocessor 1 is defective or when no processor is installed in the microprocessor 1 socket. |
| DPL01       | Yellow | CPU 2 error           | The IMM2 lights this LED and the fault LED when microprocessor 2 is defective.  |
| DPL02       | Yellow | CPU 3 error           | The IMM2 lights this LED and the fault LED when microprocessor 3 is defective.  |

Table 7. System board diagnostic LED information (continued)

| LED         | Color  | LED name               | Description   |
|-------------|--------|------------------------|---|
| DPL03       | Yellow | CPU 4 error            | The IMM2 lights this LED and the fault LED when microprocessor 4 is defective.  |
| DVL02       | Yellow | DC fault               | The IMM2 lights this LED and the fault LED when there is a power fault on one of the power rails.   |
| DML01 DML48 | Yellow | DIMM x error           | The IMM2 lights any of these LEDs and the fault LED when any DIMMs 1 – 48 are defective.  |
| DLLACT10    | Green  | Ethernet 1-0 activity  | This LED lights when there is Ethernet activity on port 0 of LOM controller 1.  |
| DLLACT11    | Green  | Ethernet 1-1 activity  | This LED lights when there is Ethernet activity on port 1 of LOM controller 1.  |
| DLLACT20    | Green  | Ethernet 2-0 activity  | This LED lights when there is Ethernet activity on port 0 of LOM controller 2.  |
| DLLACT21    | Green  | Ethernet 2-1 activity  | This LED lights when there is Ethernet activity on port 1 of LOM controller 2.  |
| DLLUP10     | Green  | Ethernet 1-0 link      | This LED lights when port 0 on LOM controller 1 is connected to the network.  |
| DLLUP11     | Green  | Ethernet 1-1 link      | This LED lights when port 1 on LOM controller 1 is connected to the network.  |
| DLLUP20     | Green  | Ethernet 2-0 link      | This LED lights when port 0 on LOM controller 2 is connected to the network.  |
| DLLUP21     | Green  | Ethernet 2-1 link      | This LED lights when port 1 on LOM controller 2 is connected to the network.  |
| DLPWROK1    | Green  | Ethernet 1 power OK    | This LED lights when power to LOM controller 1 is on and working properly.  |
| DLPWROK2    | Green  | Ethernet 2 power OK    | This LED lights when power to LOM controller 2 is on and working properly.  |
| DPWRFAULT   | Yellow | Power fault            | This LED lights when there is an overcurrent fault on one of the 12 V power rails.  |
| DS862       | Green  | RTMM heartbeat         | This LED lights when there is activity on the RTMM.   |
| DS913       | Green  | IMM heartbeat          | This LED lights when there is activity on the IMM2.   |
| DSL01       | Yellow | SAS back plane 1 error | The IMM lights this LED and the fault LED when there is a problem with SAS backplane 1.   |
| DSL02       | Yellow | SAS Back Plane 2 error | The IMM2 light this LED and the fault LED when there is a problem with SAS backplane 2.   |
| DSAS_LF10   | Yellow | SAS 1-0 link failure   | The IMM lights this LED and the fault LED when there is a fault with the link between the SAS controller and SAS Port 0 on SAS backplane 1. |
| DSAS_LF11   | Yellow | SAS 1-1 link failure   | The IMM lights this LED and the fault LED when there is a fault with the link between the SAS controller and SAS Port 1 on SAS backplane 1. |
| DSAS_LF20   | Yellow | SAS 2-0 link failure   | The IMM2 lights this LED when there is a fault with the link between the SAS controller and SAS port 0 on SAS backplane 2.                  |

Table 7. System board diagnostic LED information (continued)

| LED       | Color  | LED name             | Description  |
|-----------|--------|----------------------|--|
| DSAS_LF21 | Yellow | SAS 2-1 link failure | The IMM2 lights this LED when there is a fault with the link between the SAS controller and SAS port 1 on SAS backplane 2. |
| DSERROR   | Yellow | SAS error            | This LED lights when there is a problem with the LSI2004 SAS controller.   |
| DSHB      | Green  | SAS heartbeat        | This LED lights when there is activity on the LSI2004 SAS controller.  |

## IMM event log

Use this information as an overview of the IMM event log.

The integrated management module II (IMM2) consolidates the system-management processor functionality, video controller, and remote presence capabilities in a single chip on the system board. The IMM2 monitors all components of the compute node and posts events in the IMM event log. In addition, most events are also sent to the Chassis Management Module event log. You can view the IMM event log through the Dynamic System Analysis (DSA) program (as the ASM event log).

To diagnose and resolve IMM error codes, see “IMM messages” on page 202.

## Viewing event logs through the Setup utility

You can view the IMM and POST events through the Setup utility.

To view the POST event log or system-event log, complete the following steps:

- Step 1. Connect a keyboard, monitor, and mouse to the console breakout cable and connect the console breakout cable to the compute node.
- Step 2. Turn on the compute node.
- Step 3. When the prompt <F1> Set up is displayed, press F1. If you have set both a power-on password and an administrator password, you must type the administrator password to view the event logs.
- Step 4. Select **System Event Logs** and use one of the following procedures:
  - To view the POST event log, select **POST Event Viewer**.
  - To view the system-event log, select **System Event Log**.

## Viewing event logs without restarting the compute node

Methods are available for you to view one or more event logs without having to restart the compute node.

You can view the Chassis Management Module event log using the Lenovo XClarity Administrator, in the Flex System Manager Chassis Manager, or through the **Event Log** link in Flex System Manager management software. For more information about the Lenovo XClarity Administrator, see <https://support.lenovo.com/us/en/documents/LNVO-XCLARIT>. For more information about Flex System Manager management software, see .

You can also view the Chassis Management Module event log through the **Event Log** link by using the CMM **displaylog** command or the CMM web interface.

**Note:** If event IDs are not currently displayed in the Event Log page, you can enable them. To do so, click **Filter Events** and select the **Event ID** check box under **Visible columns**.

- For more information about the CMM **displaylog** command, see the .
- From the CMM web interface, select **Event Log** from the **Events** menu. For more information, see the . All fields and options are described in the CMM web interface online help.

If you have installed DSA Portable Edition, you can use it to view the system-event log (as the IPMI event log), the operating-system event logs, or the merged DSA log. You can also use DSA Preboot to view these logs, although you must restart the compute node to use DSA Preboot. To install Portable DSA or DSA Preboot or to download a DSA Preboot CD image, go to <https://support.lenovo.com/us/en/documents/LNVO-DSA>.

If IPMItool is installed in the compute node, you can use it to view the system-event log. Most recent versions of the Linux operating system come with a current version of IPMItool. For information about IPMItool, complete the following steps.

**Note:** Changes are made periodically to the Lenovo website. The actual procedure might vary slightly from what is described in this document.

1. Go to <http://www.ibm.com/developerworks>.
2. Click **Linux**.
3. Click the **Linux blueprints** tab.
4. Click **Blueprints for Linux on IBM systems** or **Blueprints for Linux on Lenovo systems**, and then click **Using Intelligent Platform Management Interface (IPMI) on IBM Linux platforms** or **Using Intelligent Platform Management Interface (IPMI) on Lenovo Linux platforms**.

The following table describes the methods that you can use to view the event logs, depending on the condition of the compute node. The first two conditions generally do not require that you restart the compute node.

Table 8. Methods for viewing event logs

| Condition   | Action   |
|---|--|
| The compute node is not hung and is connected to a network.     | Use any of the following methods: <ul style="list-style-type: none"> <li>• In a web browser, type the IP address of the Chassis Management Module and go to the Event Log page.</li> <li>• Run Portable or Installable DSA to view the event logs or create an output file that you can send to Support.</li> <li>• Use IPMItool to view the system-event log.</li> </ul>  |
| The compute node is not hung and is not connected to a network. | Use IPMItool locally to view the system-event log.   |
| The compute node is hung.                                       | Use any of the following methods: <ul style="list-style-type: none"> <li>• If DSA Preboot is installed, restart the compute node and press F2 to start DSA Preboot and view the event logs.</li> <li>• If DSA Preboot is not installed, insert the DSA Preboot CD and restart the compute node to start DSA Preboot and view the event logs.</li> <li>• Alternatively, you can restart the compute node and press F1 to start the Setup utility and view the POST event log or system-event log. For more information, see “Viewing event logs through the Setup utility” on page 63.</li> </ul> |

## Lenovo Dynamic System Analysis Preboot diagnostic program

Lenovo Dynamic System Analysis (DSA) Preboot diagnostic program collects and analyzes system information to aid in diagnosing compute node problems.

DSA Preboot performs the following tasks:

- Collects system information into a compressed XML file that you can send to Support
- Provides a bootable image that you can use to run extended hardware tests independent of the operating system or applications
- Collects the version and license information from local VMware ESXi hypervisor software

DSA Preboot might appear to be unresponsive when you start the program. This is normal operation while the program loads.

To obtain DSA code and the *Dynamic System Analysis Installation and User's Guide*, go to <https://support.lenovo.com/us/en/documents/LNVO-DSA>.

To diagnose and resolve DSA messages, see “DSA diagnostic test results” on page 66.

### Running DSA Preboot

Use this information to run DSA Preboot.

To run the DSA Preboot diagnostic programs, complete the following steps:

1. If the compute node is running, turn off the compute node and all attached devices.
2. Turn on all attached devices; then, turn on the compute node.
3. When the prompt <F2> Diagnostics is displayed, press F2.

**Note:** DSA Preboot might appear to be unresponsive for an unusual length of time when you start the program. This is normal operation while the program loads.

4. Select **Quit to DSA** to exit from the stand-alone memory diagnostic program.

**Note:** After you exit from the stand-alone memory diagnostic environment, you must restart the compute node to access the stand-alone memory diagnostic environment again.

5. Enter **gui** to start the DSA graphical user interface, or select **cmd** to display the DSA interactive menu.
6. From the diagnostic programs screen, select the test that you want to run, and follow the instructions on the screen. For additional information, see the *Dynamic System Analysis Installation and User's Guide*, which is available at <https://support.lenovo.com/us/en/documents/LNVO-DSA>.

Help for DSA is available. For help about the DSA CLI, enter **help** in the command line. For help with the DSA user interface, press F1. Pressing F1 within a help panel displays additional online documentation.

### Diagnostic text messages

Use this information to understand the diagnostic text messages that are displayed while the tests are running.

A diagnostic text message contains one of the following results:

- **Passed:** The test was completed without any errors.
- **Failed:** The test detected an error.
- **User Aborted:** You stopped the test before it was completed.
- **Not Applicable:** You attempted to test a device that is not present in the compute node.

- **Aborted:** The test could not proceed because of the compute node configuration.
- **Warning:** The test could not be run. There was no failure of the hardware that was being tested, but there might be a hardware failure elsewhere, or another problem prevented the test from running; for example, there might be a configuration problem, or the hardware might be missing or is not being recognized.

The result is followed by an error code or other additional information about the error.

## Viewing the test results

Use this information to view the test results.

You can use one of the following methods to access the test log when the tests are completed:

- From the DSA command line, issue the DSA CLI View command or select the **Diagnostic Event Log** option from the DSA graphical user interface (GUI).
- From the DSA interactive menu, select the **getextendedresults** option.
- From the DSA interactive menu, select the **View** option to view all of the collected results and error log data.
- In the DSA GUI, select **DSA Error Log** from the System Information page.

You can send the DSA error log file to Support to aid in diagnosing the compute node problems, or you can use the DSA CLI copy command to copy the log to an external USB device.

## DSA diagnostic test results

After running the DSA diagnostic tests, use this information to resolve any issues that were found.

### DSA CPU stress test results

The following messages can result when you run the CPU stress test.

#### Test results for the DSA CPU stress test

The following messages can result when you run the DSA CPU stress test.

- **089-000-000 : CPU Stress Test Passed**

CPU Stress Test Passed.

#### Recoverable

No

#### Severity

Event

#### Serviceable

No

#### Automatically notify support

No

#### Related links

- [IBM Support website](#)
- [Latest level of DSA](#)
- [Latest level of BMC/IMM](#)

- **089-801-000 : CPU Stress Test Aborted**

CPU Stress Test Aborted. Internal Program Error.

#### Recoverable

No

**Severity**

Warning

**Serviceable**

Yes

**Automatically notify support**

No

**User Response**

Complete the following steps:

1. Turn off and restart the system.
2. Make sure that the DSA Diagnostic code is at the latest level.
3. Run the test again.
4. Check system firmware level and upgrade if necessary. The installed firmware level can be found in the DSA Diagnostic Event Log within the Firmware/VPD section for this component. The latest level firmware for this component can be found in reference to this system type at the IBM Support website: <http://www.ibm.com/support/docview.wss?uid=psg1MIGR-4JTS2T>.
5. Run the test again.
6. If the system has stopped responding, turn off and restart the system and then run the test again.
7. If failure remains, refer to "Troubleshooting by symptom" in the system "Installation and Service Guide" for the next corrective action.

**Related links**

- [IBM Support website](#)
  - [Latest level of DSA](#)
  - [Latest level of BMC/IMM](#)
- **089-802-000 : CPU Stress Test Aborted**  
CPU Stress Test Aborted. System resource unavailability error.

**Recoverable**

No

**Severity**

Warning

**Serviceable**

Yes

**Automatically notify support**

No

**User Response**

Complete the following steps:

1. Turn off and restart the system.
2. Make sure that the DSA Diagnostic code is at the latest level.
3. Run the test again.
4. Check system firmware level and upgrade if necessary. The installed firmware level can be found in the DSA Diagnostic Event Log within the Firmware/VPD section for this component.
5. Run the test again.
6. If the system has stopped responding, turn off and restart the system and then run the test again.

7. If failure remains, refer to "Troubleshooting by symptom" in the system "Installation and Service Guide" for the next corrective action.

**Related links**

- [IBM Support website](#)
- [Latest level of DSA](#)
- [Latest level of BMC/IMM](#)

- **089-803-000 : CPU Stress Test Aborted**

CPU Stress Test Aborted. Memory size is insufficient to run the test. At least 1GB is required.

**Recoverable**

No

**Severity**

Warning

**Serviceable**

Yes

**Automatically notify support**

No

**Related links**

- [IBM Support website](#)
- [Latest level of DSA](#)
- [Latest level of BMC/IMM](#)

- **089-804-000 : CPU Stress Test Aborted**

CPU Stress Test Aborted. User pressed Ctrl-C.

**Recoverable**

No

**Severity**

Warning

**Serviceable**

Yes

**Automatically notify support**

No

**Related links**

- [IBM Support website](#)
- [Latest level of DSA](#)
- [Latest level of BMC/IMM](#)

- **089-901-000 : CPU Stress Test Failed**

CPU Stress Test Failed.

**Recoverable**

No

**Severity**

Error

**Serviceable**

Yes

**Automatically notify support**

No



## User Response

Complete the following steps:

1. If the system has stopped responding, turn off and restart the system and then run the test again.
2. Make sure that the DSA Diagnostic code is at the latest level.
3. Run the test again.
4. Check system firmware level and upgrade if necessary. The installed firmware level can be found in the DSA Diagnostic Event Log within the Firmware/VPD section for this component.
5. Run the test again.
6. If the system has stopped responding, turn off and restart the system and then run the test again.
7. If failure remains, refer to "Troubleshooting by symptom" in the system "Installation and Service Guide" for the next corrective action.

## Related links

- [IBM Support website](#)
- [Latest level of DSA](#)
- [Latest level of BMC/IMM](#)

## DSA memory stress test results

The following messages can result when you run the memory stress test.

### Test results for the DSA memory stress test

The following messages can result when you run the DSA memory stress test.

- **202-000-000 : MemStr Test Passed**

Test Passed.

**Recoverable**

No

**Severity**

Event

**Serviceable**

No

**Automatically notify support**

No

**Related links**

- [IBM Support website](#)
- [Latest level of DSA](#)
- [Latest level of BMC/IMM](#)

- **202-801-000 : MemStr Test Aborted**

Internal program error.

**Recoverable**

No

**Severity**

Warning

**Serviceable**

Yes

**Automatically notify support**

No

### User Response

Complete the following steps:

1. Turn off and restart the system.
2. Make sure that the DSA Diagnostic code is at the latest level.
3. Run the test again.
4. If the system has stopped responding, turn off and restart the system.
5. Check the system firmware level and upgrade if necessary.
6. Run the memory diagnostic to identify the specific failing DIMM.
7. If the failure remains, refer to "Troubleshooting by symptom" in the system "Installation and Service Guide" for the next corrective action.

### Related links

- [IBM Support website](#)
- [Latest level of DSA](#)
- [Latest level of BMC/IMM](#)

#### • 202-802-000 : MemStr Test Aborted

Memory size is insufficient to run the test. At least 1 GB is required.

### Recoverable

No

### Severity

Warning

### Serviceable

Yes

### Automatically notify support

No

### Related links

- [IBM Support website](#)
- [Latest level of DSA](#)
- [Latest level of BMC/IMM](#)

#### • 202-803-000 : MemStr Test Aborted

User pressed Ctrl-C.

### Recoverable

No

### Severity

Warning

### Serviceable

Yes

### Automatically notify support

No

### Related links

- [IBM Support website](#)
- [Latest level of DSA](#)
- [Latest level of BMC/IMM](#)

#### • 202-901-000 : MemStr Test Failed

Test Failed.

**Recoverable**

No

**Severity**

Error

**Serviceable**

Yes

**Automatically notify support**

No

**User Response**

Complete the following steps:

1. Execute the standard DSA memory diagnostics to validate all memory.
2. Make sure that the DSA Diagnostic code is at the latest level.
3. Turn off the system and disconnect it from power.
4. Reseat the memory cards and DIMMs.
5. Reconnect the system to power and turn the system on.
6. Run the test again.
7. Execute the standard DSA memory diagnostics to validate all memory.
8. If the failure remains, refer to "Troubleshooting by symptom" in the system "Installation and Service Guide" for the next corrective action.

**Related links**

- [IBM Support website](#)
- [Latest level of DSA](#)
- [Latest level of BMC/IMM](#)

• **202-902-000 : MemStr Test Failed**

Memory size is insufficient to run the test.

**Recoverable**

No

**Severity**

Error

**Serviceable**

Yes

**Automatically notify support**

No

**User Response**

Complete the following steps:

1. Ensure that all memory is enabled by checking the "Available System Memory" in the "Resource Utilization" section of the DSA Diagnostic Event log.
2. If necessary, access the Configuration/Setup Utility program by pressing F1 during system boot and enable all memory.
3. Make sure that the DSA Diagnostic code is at the latest level.
4. Run the test again.
5. Execute the standard DSA memory diagnostics to validate all memory.

6. If the failure remains, refer to "Troubleshooting by symptom" in the system "Installation and Service Guide" for the next corrective action.

**Related links**

- [IBM Support website](#)
- [Latest level of DSA](#)
- [Latest level of BMC/IMM](#)

**DSA memory isolation test results**

The following messages can result when you run the memory isolation test.

**Test results for the DSA memory isolation test**

The following messages can result when you run the DSA memory isolation test.

- **201-000-000 : Standalone Memory Test Passed**

Quick/Full Memory Test All CPUs Passed.

**Recoverable**

No

**Severity**

Event

**Serviceable**

No

**Automatically notify support**

No

**Related links**

- [IBM Support website](#)
- [Latest level of DSA](#)
- [Latest level of BMC/IMM](#)

- **201-000-001 : Standalone Memory Test Passed**

Quick/Full Memory Test CPU 1 Passed.

**Recoverable**

No

**Severity**

Event

**Serviceable**

No

**Automatically notify support**

No

**Related links**

- [IBM Support website](#)
- [Latest level of DSA](#)
- [Latest level of BMC/IMM](#)

- **201-000-002 : Standalone Memory Test Passed**

Quick/Full Memory Test CPU 2 Passed.

**Recoverable**

No

**Severity**

Event

**Serviceable**

No

**Automatically notify support**

No

**Related links**

- [IBM Support website](#)
- [Latest level of DSA](#)
- [Latest level of BMC/IMM](#)

- **201-000-003 : Standalone Memory Test Passed**

Quick/Full Memory Test CPU 3 Passed.

**Recoverable**

No

**Severity**

Event

**Serviceable**

No

**Automatically notify support**

No

**Related links**

- [IBM Support website](#)
- [Latest level of DSA](#)
- [Latest level of BMC/IMM](#)

- **201-000-004 : Standalone Memory Test Passed**

Quick/Full Memory Test CPU 4 Passed.

**Recoverable**

No

**Severity**

Event

**Serviceable**

No

**Automatically notify support**

No

**Related links**

- [IBM Support website](#)
- [Latest level of DSA](#)
- [Latest level of BMC/IMM](#)

- **201-811-000 : Standalone Memory Test Aborted**

Unable to Locate SMBIOS key "\_SM\_".

**Recoverable**

No

**Severity**

Warning

**Serviceable**

No

**Automatically notify support**

No

**User Response**

Complete the following steps:

1. Perform the actions mentioned one at a time and try the test after each action.
2. If the problem remains, contact your technical-service representative.
3. Turn off the system and disconnect it from power. Wait for 45 seconds. Reseat DIMM(s). Reconnect it to power.
4. Make sure that DSA and BIOS/uEFI are at the latest level.

**Related links**

- [IBM Support website](#)
- [Latest level of DSA](#)
- [Latest level of BMC/IMM](#)

- **201-811-001 : Standalone Memory Test Aborted**

Unable to Locate SMBIOS key "\_SM\_".

**Recoverable**

No

**Severity**

Warning

**Serviceable**

No

**Automatically notify support**

No

**User Response**

Complete the following steps:

1. Perform the actions mentioned one at a time and try the test after each action.
2. If the problem remains, contact your technical-service representative.
3. Turn off the system and disconnect it from power. Wait for 45 seconds. Reseat DIMM(s). Reconnect it to power.
4. Make sure that DSA and BIOS/uEFI are at the latest level.

**Related links**

- [IBM Support website](#)
- [Latest level of DSA](#)
- [Latest level of BMC/IMM](#)

- **201-811-002 : Standalone Memory Test Aborted**

Unable to Locate SMBIOS key "\_SM\_".

**Recoverable**

No

**Severity**

Warning

**Serviceable**

No

**Automatically notify support**

No

**User Response**

Complete the following steps:

1. Perform the actions mentioned one at a time and try the test after each action.
2. If the problem remains, contact your technical-service representative.
3. Turn off the system and disconnect it from power. Wait for 45 seconds. Reseat DIMM(s). Reconnect it to power.
4. Make sure that DSA and BIOS/uEFI are at the latest level.

**Related links**

- [IBM Support website](#)
- [Latest level of DSA](#)
- [Latest level of BMC/IMM](#)

- **201-811-003 : Standalone Memory Test Aborted**

Unable to Locate SMBIOS key "\_SM\_".

**Recoverable**

No

**Severity**

Warning

**Serviceable**

No

**Automatically notify support**

No

**User Response**

Complete the following steps:

1. Perform the actions mentioned one at a time and try the test after each action.
2. If the problem remains, contact your technical-service representative.
3. Turn off the system and disconnect it from power. Wait for 45 seconds. Reseat DIMM(s). Reconnect it to power.
4. Make sure that DSA and BIOS/uEFI are at the latest level.

**Related links**

- [IBM Support website](#)
- [Latest level of DSA](#)
- [Latest level of BMC/IMM](#)

- **201-812-000 : Standalone Memory Test Aborted**

Memory test is not supported for this system.

**Recoverable**

No

**Severity**

Warning

**Serviceable**

No

**Automatically notify support**

No

**User Response**

Complete the following steps:

1. Perform the actions mentioned one at a time and try the test after each action.
2. If the problem remains, contact your technical-service representative.
3. Turn off the system and disconnect it from power. Wait for 45 seconds. Reseat DIMM(s). Reconnect it to power.
4. Make sure that DSA and BIOS/uEFI are at the latest level.

**Related links**

- [IBM Support website](#)
- [Latest level of DSA](#)
- [Latest level of BMC/IMM](#)

- **201-812-001 : Standalone Memory Test Aborted**

Memory test is not supported for this system.

**Recoverable**

No

**Severity**

Warning

**Serviceable**

No

**Automatically notify support**

No

**User Response**

Complete the following steps:

1. Perform the actions mentioned one at a time and try the test after each action.
2. If the problem remains, contact your technical-service representative.
3. Turn off the system and disconnect it from power. Wait for 45 seconds. Reseat DIMM(s). Reconnect it to power.
4. Make sure that DSA and BIOS/uEFI are at the latest level.

**Related links**

- [IBM Support website](#)
- [Latest level of DSA](#)
- [Latest level of BMC/IMM](#)

- **201-812-002 : Standalone Memory Test Aborted**

Memory test is not supported for this system.

**Recoverable**

No

**Severity**

Warning

**Serviceable**

No

**Automatically notify support**

No

**User Response**

Complete the following steps:



1. Perform the actions mentioned one at a time and try the test after each action.
2. If the problem remains, contact your technical-service representative.
3. Turn off the system and disconnect it from power. Wait for 45 seconds. Reseat DIMM(s). Reconnect it to power.
4. Make sure that DSA and BIOS/uEFI are at the latest level.

**Related links**

- [IBM Support website](#)
- [Latest level of DSA](#)
- [Latest level of BMC/IMM](#)

- **201-812-003 : Standalone Memory Test Aborted**

Memory test is not supported for this system.

**Recoverable**

No

**Severity**

Warning

**Serviceable**

No

**Automatically notify support**

No

**User Response**

Complete the following steps:

1. Perform the actions mentioned one at a time and try the test after each action.
2. If the problem remains, contact your technical-service representative.
3. Turn off the system and disconnect it from power. Wait for 45 seconds. Reseat DIMM(s). Reconnect it to power.
4. Make sure that DSA and BIOS/uEFI are at the latest level.

**Related links**

- [IBM Support website](#)
- [Latest level of DSA](#)
- [Latest level of BMC/IMM](#)

- **201-813-000 : Standalone Memory Test Aborted**

Chipset Error: Can not turn OFF ECC error reporting in CPU.

**Recoverable**

No

**Severity**

Warning

**Serviceable**

No

**Automatically notify support**

No

**User Response**

Complete the following steps:

1. Perform the actions mentioned one at a time and try the test after each action.
2. If the problem remains, contact your technical-service representative.

3. Turn off the system and disconnect it from power. Wait for 45 seconds. Reseat DIMM(s). Reconnect it to power.
4. Make sure that DSA and BIOS/uEFI are at the latest level.

**Related links**

- [IBM Support website](#)
- [Latest level of DSA](#)
- [Latest level of BMC/IMM](#)

- **201-813-001 : Standalone Memory Test Aborted**

Chipset Error: Can not turn OFF ECC error reporting in CPU.

**Recoverable**

No

**Severity**

Warning

**Serviceable**

No

**Automatically notify support**

No

**User Response**

Complete the following steps:

1. Perform the actions mentioned one at a time and try the test after each action.
2. If the problem remains, contact your technical-service representative.
3. Turn off the system and disconnect it from power. Wait for 45 seconds. Reseat DIMM(s). Reconnect it to power.
4. Make sure that DSA and BIOS/uEFI are at the latest level.

**Related links**

- [IBM Support website](#)
- [Latest level of DSA](#)
- [Latest level of BMC/IMM](#)

- **201-813-002 : Standalone Memory Test Aborted**

Chipset Error: Can not turn OFF ECC error reporting in CPU.

**Recoverable**

No

**Severity**

Warning

**Serviceable**

No

**Automatically notify support**

No

**User Response**

Complete the following steps:

1. Perform the actions mentioned one at a time and try the test after each action.
2. If the problem remains, contact your technical-service representative.
3. Turn off the system and disconnect it from power. Wait for 45 seconds. Reseat DIMM(s). Reconnect it to power.

4. Make sure that DSA and BIOS/uEFI are at the latest level.

**Related links**

- [IBM Support website](#)
- [Latest level of DSA](#)
- [Latest level of BMC/IMM](#)

- **201-813-003 : Standalone Memory Test Aborted**

Chipset Error: Can not turn OFF ECC error reporting in CPU.

**Recoverable**

No

**Severity**

Warning

**Serviceable**

No

**Automatically notify support**

No

**User Response**

Complete the following steps:

1. Perform the actions mentioned one at a time and try the test after each action.
2. If the problem remains, contact your technical-service representative.
3. Turn off the system and disconnect it from power. Wait for 45 seconds. Reseat DIMM(s). Reconnect it to power.
4. Make sure that DSA and BIOS/uEFI are at the latest level.

**Related links**

- [IBM Support website](#)
- [Latest level of DSA](#)
- [Latest level of BMC/IMM](#)

- **201-814-000 : Standalone Memory Test Aborted**

Chipset Error: Can not disable Scubbing feature for CPU.

**Recoverable**

No

**Severity**

Warning

**Serviceable**

No

**Automatically notify support**

No

**User Response**

Complete the following steps:

1. Perform the actions mentioned one at a time and try the test after each action.
2. If the problem remains, contact your technical-service representative.
3. Turn off the system and disconnect it from power. Wait for 45 seconds. Reseat DIMM(s). Reconnect it to power.
4. Make sure that DSA and BIOS/uEFI are at the latest level.

**Related links**

- [IBM Support website](#)
- [Latest level of DSA](#)
- [Latest level of BMC/IMM](#)

- **201-814-001 : Standalone Memory Test Aborted**

Chipset Error: Can not disable Scubbing feature for CPU.

**Recoverable**

No

**Severity**

Warning

**Serviceable**

No

**Automatically notify support**

No

**User Response**

Complete the following steps:

1. Perform the actions mentioned one at a time and try the test after each action.
2. If the problem remains, contact your technical-service representative.
3. Turn off the system and disconnect it from power. Wait for 45 seconds. Reseat DIMM(s). Reconnect it to power.
4. Make sure that DSA and BIOS/uEFI are at the latest level.

**Related links**

- [IBM Support website](#)
- [Latest level of DSA](#)
- [Latest level of BMC/IMM](#)

- **201-814-002 : Standalone Memory Test Aborted**

Chipset Error: Can not disable Scubbing feature for CPU.

**Recoverable**

No

**Severity**

Warning

**Serviceable**

No

**Automatically notify support**

No

**User Response**

Complete the following steps:

1. Perform the actions mentioned one at a time and try the test after each action.
2. If the problem remains, contact your technical-service representative.
3. Turn off the system and disconnect it from power. Wait for 45 seconds. Reseat DIMM(s). Reconnect it to power.
4. Make sure that DSA and BIOS/uEFI are at the latest level.

**Related links**

- [IBM Support website](#)
- [Latest level of DSA](#)

- [Latest level of BMC/IMM](#)
- **201-814-003 : Standalone Memory Test Aborted**  
Chipset Error: Can not disable Scubbing feature for CPU.

**Recoverable**

No

**Severity**

Warning

**Serviceable**

No

**Automatically notify support**

No

**User Response**

Complete the following steps:

1. Perform the actions mentioned one at a time and try the test after each action.
2. If the problem remains, contact your technical-service representative.
3. Turn off the system and disconnect it from power. Wait for 45 seconds. Reseat DIMM(s). Reconnect it to power.
4. Make sure that DSA and BIOS/uEFI are at the latest level.

**Related links**

- [IBM Support website](#)
- [Latest level of DSA](#)
- [Latest level of BMC/IMM](#)
- **201-815-000 : Standalone Memory Test Aborted**  
Program Error with Quick Memory Menu Option Selection.

**Recoverable**

No

**Severity**

Warning

**Serviceable**

No

**Automatically notify support**

No

**User Response**

Complete the following steps:

1. Perform the actions mentioned one at a time and try the test after each action.
2. If the problem remains, contact your technical-service representative.
3. Turn off the system and disconnect it from power. Wait for 45 seconds. Reseat DIMM(s). Reconnect it to power.
4. Make sure that DSA and BIOS/uEFI are at the latest level.

**Related links**

- [IBM Support website](#)
- [Latest level of DSA](#)
- [Latest level of BMC/IMM](#)
- **201-815-001 : Standalone Memory Test Aborted**

Program Error with Quick Memory Menu Option Selection.

**Recoverable**

No

**Severity**

Warning

**Serviceable**

No

**Automatically notify support**

No

**User Response**

Complete the following steps:

1. Perform the actions mentioned one at a time and try the test after each action.
2. If the problem remains, contact your technical-service representative.
3. Turn off the system and disconnect it from power. Wait for 45 seconds. Reseat DIMM(s). Reconnect it to power.
4. Make sure that DSA and BIOS/uEFI are at the latest level.

**Related links**

- [IBM Support website](#)
- [Latest level of DSA](#)
- [Latest level of BMC/IMM](#)

• **201-815-002 : Standalone Memory Test Aborted**

Program Error with Quick Memory Menu Option Selection.

**Recoverable**

No

**Severity**

Warning

**Serviceable**

No

**Automatically notify support**

No

**User Response**

Complete the following steps:

1. Perform the actions mentioned one at a time and try the test after each action.
2. If the problem remains, contact your technical-service representative.
3. Turn off the system and disconnect it from power. Wait for 45 seconds. Reseat DIMM(s). Reconnect it to power.
4. Make sure that DSA and BIOS/uEFI are at the latest level.

**Related links**

- [IBM Support website](#)
- [Latest level of DSA](#)
- [Latest level of BMC/IMM](#)

• **201-815-003 : Standalone Memory Test Aborted**

Program Error with Quick Memory Menu Option Selection.

**Recoverable**

No

**Severity**

Warning

**Serviceable**

No

**Automatically notify support**

No

**User Response**

Complete the following steps:

1. Perform the actions mentioned one at a time and try the test after each action.
2. If the problem remains, contact your technical-service representative.
3. Turn off the system and disconnect it from power. Wait for 45 seconds. Reseat DIMM(s). Reconnect it to power.
4. Make sure that DSA and BIOS/uEFI are at the latest level.

**Related links**

- [IBM Support website](#)
- [Latest level of DSA](#)
- [Latest level of BMC/IMM](#)

- **201-816-000 : Standalone Memory Test Aborted**

Program Error with Full Memory Menu Option Selection.

**Recoverable**

No

**Severity**

Warning

**Serviceable**

No

**Automatically notify support**

No

**User Response**

Complete the following steps:

1. Perform the actions mentioned one at a time and try the test after each action.
2. If the problem remains, contact your technical-service representative.
3. Turn off the system and disconnect it from power. Wait for 45 seconds. Reseat DIMM(s). Reconnect it to power.
4. Make sure that DSA and BIOS/uEFI are at the latest level.

**Related links**

- [IBM Support website](#)
- [Latest level of DSA](#)
- [Latest level of BMC/IMM](#)

- **201-816-001 : Standalone Memory Test Aborted**

Program Error with Full Memory Menu Option Selection.

**Recoverable**

No

**Severity**

Warning

**Serviceable**

No

**Automatically notify support**

No

**User Response**

Complete the following steps:

1. Perform the actions mentioned one at a time and try the test after each action.
2. If the problem remains, contact your technical-service representative.
3. Turn off the system and disconnect it from power. Wait for 45 seconds. Reseat DIMM(s). Reconnect it to power.
4. Make sure that DSA and BIOS/uEFI are at the latest level.

**Related links**

- [IBM Support website](#)
- [Latest level of DSA](#)
- [Latest level of BMC/IMM](#)

- **201-816-002 : Standalone Memory Test Aborted**

Program Error with Full Memory Menu Option Selection.

**Recoverable**

No

**Severity**

Warning

**Serviceable**

No

**Automatically notify support**

No

**User Response**

Complete the following steps:

1. Perform the actions mentioned one at a time and try the test after each action.
2. If the problem remains, contact your technical-service representative.
3. Turn off the system and disconnect it from power. Wait for 45 seconds. Reseat DIMM(s). Reconnect it to power.
4. Make sure that DSA and BIOS/uEFI are at the latest level.

**Related links**

- [IBM Support website](#)
- [Latest level of DSA](#)
- [Latest level of BMC/IMM](#)

- **201-816-003 : Standalone Memory Test Aborted**

Program Error with Full Memory Menu Option Selection.

**Recoverable**

No

**Severity**

Warning



**Serviceable**

No

**Automatically notify support**

No

**User Response**

Complete the following steps:

1. Perform the actions mentioned one at a time and try the test after each action.
2. If the problem remains, contact your technical-service representative.
3. Turn off the system and disconnect it from power. Wait for 45 seconds. Reseat DIMM(s). Reconnect it to power.
4. Make sure that DSA and BIOS/uEFI are at the latest level.

**Related links**

- [IBM Support website](#)
- [Latest level of DSA](#)
- [Latest level of BMC/IMM](#)

- **201-818-000 : Standalone Memory Test Aborted**

Unable to Locate SMBIOS key "\_SM\_".

**Recoverable**

No

**Severity**

Warning

**Serviceable**

No

**Automatically notify support**

No

**User Response**

Complete the following steps:

1. Perform the actions mentioned one at a time and try the test after each action.
2. If the problem remains, contact your technical-service representative.
3. Turn off the system and disconnect it from power. Wait for 45 seconds. Reseat DIMM(s). Reconnect it to power.
4. Make sure that DSA and BIOS/uEFI are at the latest level.

**Related links**

- [IBM Support website](#)
- [Latest level of DSA](#)
- [Latest level of BMC/IMM](#)

- **201-818-001 : Standalone Memory Test Aborted**

Unable to Locate SMBIOS key "\_SM\_".

**Recoverable**

No

**Severity**

Warning

**Serviceable**

No

**Automatically notify support**

No

**User Response**

Complete the following steps:

1. Perform the actions mentioned one at a time and try the test after each action.
2. If the problem remains, contact your technical-service representative.
3. Turn off the system and disconnect it from power. Wait for 45 seconds. Reseat DIMM(s). Reconnect it to power.
4. Make sure that DSA and BIOS/uEFI are at the latest level.

**Related links**

- [IBM Support website](#)
- [Latest level of DSA](#)
- [Latest level of BMC/IMM](#)

**• 201-818-002 : Standalone Memory Test Aborted**

Unable to Locate SMBIOS key "\_SM\_".

**Recoverable**

No

**Severity**

Warning

**Serviceable**

No

**Automatically notify support**

No

**User Response**

Complete the following steps:

1. Perform the actions mentioned one at a time and try the test after each action.
2. If the problem remains, contact your technical-service representative.
3. Turn off the system and disconnect it from power. Wait for 45 seconds. Reseat DIMM(s). Reconnect it to power.
4. Make sure that DSA and BIOS/uEFI are at the latest level.

**Related links**

- [IBM Support website](#)
- [Latest level of DSA](#)
- [Latest level of BMC/IMM](#)

**• 201-818-003 : Standalone Memory Test Aborted**

Unable to Locate SMBIOS key "\_SM\_".

**Recoverable**

No

**Severity**

Warning

**Serviceable**

No

**Automatically notify support**

No

**User Response**

Complete the following steps:

1. Perform the actions mentioned one at a time and try the test after each action.
2. If the problem remains, contact your technical-service representative.
3. Turn off the system and disconnect it from power. Wait for 45 seconds. Reseat DIMM(s). Reconnect it to power.
4. Make sure that DSA and BIOS/uEFI are at the latest level.

**Related links**

- [IBM Support website](#)
- [Latest level of DSA](#)
- [Latest level of BMC/IMM](#)

- **201-819-000 : Standalone Memory Test Aborted**

The start-end address ranges in the restricted area of the memory.

**Recoverable**

No

**Severity**

Warning

**Serviceable**

No

**Automatically notify support**

No

**User Response**

Complete the following steps:

1. Perform the actions mentioned one at a time and try the test after each action.
2. If the problem remains, contact your technical-service representative.
3. Turn off the system and disconnect it from power. Wait for 45 seconds. Reseat DIMM(s). Reconnect it to power.
4. Make sure that DSA and BIOS/uEFI are at the latest level.

**Related links**

- [IBM Support website](#)
- [Latest level of DSA](#)
- [Latest level of BMC/IMM](#)

- **201-819-001 : Standalone Memory Test Aborted**

The start-end address ranges in the restricted area of the memory.

**Recoverable**

No

**Severity**

Warning

**Serviceable**

No

**Automatically notify support**

No

**User Response**

Complete the following steps:

1. Perform the actions mentioned one at a time and try the test after each action.
2. If the problem remains, contact your technical-service representative.
3. Turn off the system and disconnect it from power. Wait for 45 seconds. Reseat DIMM(s). Reconnect it to power.
4. Make sure that DSA and BIOS/uEFI are at the latest level.

**Related links**

- [IBM Support website](#)
- [Latest level of DSA](#)
- [Latest level of BMC/IMM](#)

**• 201-819-002 : Standalone Memory Test Aborted**

The start-end address ranges in the restricted area of the memory.

**Recoverable**

No

**Severity**

Warning

**Serviceable**

No

**Automatically notify support**

No

**User Response**

Complete the following steps:

1. Perform the actions mentioned one at a time and try the test after each action.
2. If the problem remains, contact your technical-service representative.
3. Turn off the system and disconnect it from power. Wait for 45 seconds. Reseat DIMM(s). Reconnect it to power.
4. Make sure that DSA and BIOS/uEFI are at the latest level.

**Related links**

- [IBM Support website](#)
- [Latest level of DSA](#)
- [Latest level of BMC/IMM](#)

**• 201-819-003 : Standalone Memory Test Aborted**

The start-end address ranges in the restricted area of the memory.

**Recoverable**

No

**Severity**

Warning

**Serviceable**

No

**Automatically notify support**

No

**User Response**

Complete the following steps:

1. Perform the actions mentioned one at a time and try the test after each action.
2. If the problem remains, contact your technical-service representative.

3. Turn off the system and disconnect it from power. Wait for 45 seconds. Reseat DIMM(s). Reconnect it to power.
4. Make sure that DSA and BIOS/uEFI are at the latest level.

**Related links**

- [IBM Support website](#)
- [Latest level of DSA](#)
- [Latest level of BMC/IMM](#)

- **201-820-000 : Standalone Memory Test Aborted**

Memory Upper limit is less than 16 Mbytes.

**Recoverable**

No

**Severity**

Warning

**Serviceable**

No

**Automatically notify support**

No

**User Response**

Complete the following steps:

1. Perform the actions mentioned one at a time and try the test after each action.
2. If the problem remains, contact your technical-service representative.
3. Turn off the system and disconnect it from power. Wait for 45 seconds. Reseat DIMM(s). Reconnect it to power.
4. Make sure that DSA and BIOS/uEFI are at the latest level.

**Related links**

- [IBM Support website](#)
- [Latest level of DSA](#)
- [Latest level of BMC/IMM](#)

- **201-820-001 : Standalone Memory Test Aborted**

Memory Upper limit is less than 16 Mbytes.

**Recoverable**

No

**Severity**

Warning

**Serviceable**

No

**Automatically notify support**

No

**User Response**

Complete the following steps:

1. Perform the actions mentioned one at a time and try the test after each action.
2. If the problem remains, contact your technical-service representative.
3. Turn off the system and disconnect it from power. Wait for 45 seconds. Reseat DIMM(s). Reconnect it to power.

4. Make sure that DSA and BIOS/uEFI are at the latest level.

**Related links**

- [IBM Support website](#)
- [Latest level of DSA](#)
- [Latest level of BMC/IMM](#)

- **201-820-002 : Standalone Memory Test Aborted**

Memory Upper limit is less than 16 Mbytes.

**Recoverable**

No

**Severity**

Warning

**Serviceable**

No

**Automatically notify support**

No

**User Response**

Complete the following steps:

1. Perform the actions mentioned one at a time and try the test after each action.
2. If the problem remains, contact your technical-service representative.
3. Turn off the system and disconnect it from power. Wait for 45 seconds. Reseat DIMM(s).  
Reconnect it to power.
4. Make sure that DSA and BIOS/uEFI are at the latest level.

**Related links**

- [IBM Support website](#)
- [Latest level of DSA](#)
- [Latest level of BMC/IMM](#)

- **201-820-003 : Standalone Memory Test Aborted**

Memory Upper limit is less than 16 Mbytes.

**Recoverable**

No

**Severity**

Warning

**Serviceable**

No

**Automatically notify support**

No

**User Response**

Complete the following steps:

1. Perform the actions mentioned one at a time and try the test after each action.
2. If the problem remains, contact your technical-service representative.
3. Turn off the system and disconnect it from power. Wait for 45 seconds. Reseat DIMM(s).  
Reconnect it to power.
4. Make sure that DSA and BIOS/uEFI are at the latest level.

**Related links**

- [IBM Support website](#)
- [Latest level of DSA](#)
- [Latest level of BMC/IMM](#)

- **201-821-000 : Standalone Memory Test Aborted**

Variable range MTRR registers are larger than fixed range MTRR registers.

**Recoverable**

No

**Severity**

Warning

**Serviceable**

No

**Automatically notify support**

No

**User Response**

Complete the following steps:

1. Perform the actions mentioned one at a time and try the test after each action.
2. If the problem remains, contact your technical-service representative.
3. Turn off the system and disconnect it from power. Wait for 45 seconds. Reseat DIMM(s). Reconnect it to power.
4. Make sure that DSA and BIOS/uEFI are at the latest level.

**Related links**

- [IBM Support website](#)
- [Latest level of DSA](#)
- [Latest level of BMC/IMM](#)

- **201-821-001 : Standalone Memory Test Aborted**

Variable range MTRR registers are larger than fixed range MTRR registers.

**Recoverable**

No

**Severity**

Warning

**Serviceable**

No

**Automatically notify support**

No

**User Response**

Complete the following steps:

1. Perform the actions mentioned one at a time and try the test after each action.
2. If the problem remains, contact your technical-service representative.
3. Turn off the system and disconnect it from power. Wait for 45 seconds. Reseat DIMM(s). Reconnect it to power.
4. Make sure that DSA and BIOS/uEFI are at the latest level.

**Related links**

- [IBM Support website](#)
- [Latest level of DSA](#)

- [Latest level of BMC/IMM](#)

- **201-821-002 : Standalone Memory Test Aborted**

Variable range MTRR registers are larger than fixed range MTRR registers.

**Recoverable**

No

**Severity**

Warning

**Serviceable**

No

**Automatically notify support**

No

**User Response**

Complete the following steps:

1. Perform the actions mentioned one at a time and try the test after each action.
2. If the problem remains, contact your technical-service representative.
3. Turn off the system and disconnect it from power. Wait for 45 seconds. Reseat DIMM(s). Reconnect it to power.
4. Make sure that DSA and BIOS/uEFI are at the latest level.

**Related links**

- [IBM Support website](#)
- [Latest level of DSA](#)
- [Latest level of BMC/IMM](#)

- **201-821-003 : Standalone Memory Test Aborted**

Variable range MTRR registers are larger than fixed range MTRR registers.

**Recoverable**

No

**Severity**

Warning

**Serviceable**

No

**Automatically notify support**

No

**User Response**

Complete the following steps:

1. Perform the actions mentioned one at a time and try the test after each action.
2. If the problem remains, contact your technical-service representative.
3. Turn off the system and disconnect it from power. Wait for 45 seconds. Reseat DIMM(s). Reconnect it to power.
4. Make sure that DSA and BIOS/uEFI are at the latest level.

**Related links**

- [IBM Support website](#)
- [Latest level of DSA](#)
- [Latest level of BMC/IMM](#)

- **201-822-000 : Standalone Memory Test Aborted**



Invalid MTRR service request.

**Recoverable**

No

**Severity**

Warning

**Serviceable**

No

**Automatically notify support**

No

**User Response**

Complete the following steps:

1. Perform the actions mentioned one at a time and try the test after each action.
2. If the problem remains, contact your technical-service representative.
3. Turn off the system and disconnect it from power. Wait for 45 seconds. Reseat DIMM(s). Reconnect it to power.
4. Make sure that DSA and BIOS/uEFI are at the latest level.

**Related links**

- [IBM Support website](#)
- [Latest level of DSA](#)
- [Latest level of BMC/IMM](#)

• **201-822-001 : Standalone Memory Test Aborted**

Invalid MTRR service request.

**Recoverable**

No

**Severity**

Warning

**Serviceable**

No

**Automatically notify support**

No

**User Response**

Complete the following steps:

1. Perform the actions mentioned one at a time and try the test after each action.
2. If the problem remains, contact your technical-service representative.
3. Turn off the system and disconnect it from power. Wait for 45 seconds. Reseat DIMM(s). Reconnect it to power.
4. Make sure that DSA and BIOS/uEFI are at the latest level.

**Related links**

- [IBM Support website](#)
- [Latest level of DSA](#)
- [Latest level of BMC/IMM](#)

• **201-822-002 : Standalone Memory Test Aborted**

Invalid MTRR service request.

**Recoverable**

No

**Severity**

Warning

**Serviceable**

No

**Automatically notify support**

No

**User Response**

Complete the following steps:

1. Perform the actions mentioned one at a time and try the test after each action.
2. If the problem remains, contact your technical-service representative.
3. Turn off the system and disconnect it from power. Wait for 45 seconds. Reseat DIMM(s). Reconnect it to power.
4. Make sure that DSA and BIOS/uEFI are at the latest level.

**Related links**

- [IBM Support website](#)
- [Latest level of DSA](#)
- [Latest level of BMC/IMM](#)

- **201-822-003 : Standalone Memory Test Aborted**

Invalid MTRR service request.

**Recoverable**

No

**Severity**

Warning

**Serviceable**

No

**Automatically notify support**

No

**User Response**

Complete the following steps:

1. Perform the actions mentioned one at a time and try the test after each action.
2. If the problem remains, contact your technical-service representative.
3. Turn off the system and disconnect it from power. Wait for 45 seconds. Reseat DIMM(s). Reconnect it to power.
4. Make sure that DSA and BIOS/uEFI are at the latest level.

**Related links**

- [IBM Support website](#)
- [Latest level of DSA](#)
- [Latest level of BMC/IMM](#)

- **201-824-000 : Standalone Memory Test Aborted**

Node Interleave feature must be OFF. Go to Setup and disable Node Interleave option and then re-run the test.

**Recoverable**

No

**Severity**

Warning

**Serviceable**

No

**Automatically notify support**

No

**User Response**

Complete the following steps:

1. Perform the actions mentioned one at a time and try the test after each action.
2. If the problem remains, contact your technical-service representative.
3. Turn off the system and disconnect it from power. Wait for 45 seconds. Reseat DIMM(s). Reconnect it to power.
4. Make sure that DSA and BIOS/uEFI are at the latest level.

**Related links**

- [IBM Support website](#)
- [Latest level of DSA](#)
- [Latest level of BMC/IMM](#)

• **201-824-001 : Standalone Memory Test Aborted**

Node Interleave feature must be OFF. Go to Setup and disable Node Interleave option and then re-run the test.

**Recoverable**

No

**Severity**

Warning

**Serviceable**

No

**Automatically notify support**

No

**User Response**

Complete the following steps:

1. Perform the actions mentioned one at a time and try the test after each action.
2. If the problem remains, contact your technical-service representative.
3. Turn off the system and disconnect it from power. Wait for 45 seconds. Reseat DIMM(s). Reconnect it to power.
4. Make sure that DSA and BIOS/uEFI are at the latest level.

**Related links**

- [IBM Support website](#)
- [Latest level of DSA](#)
- [Latest level of BMC/IMM](#)

• **201-824-002 : Standalone Memory Test Aborted**

Node Interleave feature must be OFF. Go to Setup and disable Node Interleave option and then re-run the test.

**Recoverable**

No

**Severity**

Warning

**Serviceable**

No

**Automatically notify support**

No

**User Response**

Complete the following steps:

1. Perform the actions mentioned one at a time and try the test after each action.
2. If the problem remains, contact your technical-service representative.
3. Turn off the system and disconnect it from power. Wait for 45 seconds. Reseat DIMM(s). Reconnect it to power.
4. Make sure that DSA and BIOS/uEFI are at the latest level.

**Related links**

- [IBM Support website](#)
- [Latest level of DSA](#)
- [Latest level of BMC/IMM](#)

• **201-824-003 : Standalone Memory Test Aborted**

Node Interleave feature must be OFF. Go to Setup and disable Node Interleave option and then re-run the test.

**Recoverable**

No

**Severity**

Warning

**Serviceable**

No

**Automatically notify support**

No

**User Response**

Complete the following steps:

1. Perform the actions mentioned one at a time and try the test after each action.
2. If the problem remains, contact your technical-service representative.
3. Turn off the system and disconnect it from power. Wait for 45 seconds. Reseat DIMM(s). Reconnect it to power.
4. Make sure that DSA and BIOS/uEFI are at the latest level.

**Related links**

- [IBM Support website](#)
- [Latest level of DSA](#)
- [Latest level of BMC/IMM](#)

• **201-826-000 : Standalone Memory Test Aborted**

BIOS: Memory Controller has been disabled. Go to Setup and Enable Memory Controller.

**Recoverable**

No

**Severity**

Warning

**Serviceable**

No

**Automatically notify support**

No

**User Response**

Complete the following steps:

1. Perform the actions mentioned one at a time and try the test after each action.
2. If the problem remains, contact your technical-service representative.
3. Turn off the system and disconnect it from power. Wait for 45 seconds. Reseat DIMM(s). Reconnect it to power.
4. Make sure that DSA and BIOS/uEFI are at the latest level.

**Related links**

- [IBM Support website](#)
- [Latest level of DSA](#)
- [Latest level of BMC/IMM](#)

- **201-826-001 : Standalone Memory Test Aborted**

BIOS: Memory Controller has been disabled. Go to Setup and Enable Memory Controller.

**Recoverable**

No

**Severity**

Warning

**Serviceable**

No

**Automatically notify support**

No

**User Response**

Complete the following steps:

1. Perform the actions mentioned one at a time and try the test after each action.
2. If the problem remains, contact your technical-service representative.
3. Turn off the system and disconnect it from power. Wait for 45 seconds. Reseat DIMM(s). Reconnect it to power.
4. Make sure that DSA and BIOS/uEFI are at the latest level.

**Related links**

- [IBM Support website](#)
- [Latest level of DSA](#)
- [Latest level of BMC/IMM](#)

- **201-826-002 : Standalone Memory Test Aborted**

BIOS: Memory Controller has been disabled. Go to Setup and Enable Memory Controller.

**Recoverable**

No

**Severity**

Warning

**Serviceable**

No

**Automatically notify support**

No

**User Response**

Complete the following steps:

1. Perform the actions mentioned one at a time and try the test after each action.
2. If the problem remains, contact your technical-service representative.
3. Turn off the system and disconnect it from power. Wait for 45 seconds. Reseat DIMM(s). Reconnect it to power.
4. Make sure that DSA and BIOS/uEFI are at the latest level.

**Related links**

- [IBM Support website](#)
- [Latest level of DSA](#)
- [Latest level of BMC/IMM](#)

- **201-826-003 : Standalone Memory Test Aborted**

BIOS: Memory Controller has been disabled. Go to Setup and Enable Memory Controller.

**Recoverable**

No

**Severity**

Warning

**Serviceable**

No

**Automatically notify support**

No

**User Response**

Complete the following steps:

1. Perform the actions mentioned one at a time and try the test after each action.
2. If the problem remains, contact your technical-service representative.
3. Turn off the system and disconnect it from power. Wait for 45 seconds. Reseat DIMM(s). Reconnect it to power.
4. Make sure that DSA and BIOS/uEFI are at the latest level.

**Related links**

- [IBM Support website](#)
- [Latest level of DSA](#)
- [Latest level of BMC/IMM](#)

- **201-827-000 : Standalone Memory Test Aborted**

BIOS: ECC function has been disabled by BIOS. Go to Setup and enable ECC generation.

**Recoverable**

No

**Severity**

Warning

**Serviceable**

No

**Automatically notify support**

No

**User Response**

Complete the following steps:

1. Perform the actions mentioned one at a time and try the test after each action.
2. If the problem remains, contact your technical-service representative.
3. Turn off the system and disconnect it from power. Wait for 45 seconds. Reseat DIMM(s). Reconnect it to power.
4. Make sure that DSA and BIOS/uEFI are at the latest level.

**Related links**

- [IBM Support website](#)
- [Latest level of DSA](#)
- [Latest level of BMC/IMM](#)

- **201-827-001 : Standalone Memory Test Aborted**

BIOS: ECC function has been disabled by BIOS. Go to Setup and enable ECC generation.

**Recoverable**

No

**Severity**

Warning

**Serviceable**

No

**Automatically notify support**

No

**User Response**

Complete the following steps:

1. Perform the actions mentioned one at a time and try the test after each action.
2. If the problem remains, contact your technical-service representative.
3. Turn off the system and disconnect it from power. Wait for 45 seconds. Reseat DIMM(s). Reconnect it to power.
4. Make sure that DSA and BIOS/uEFI are at the latest level.

**Related links**

- [IBM Support website](#)
- [Latest level of DSA](#)
- [Latest level of BMC/IMM](#)

- **201-827-002 : Standalone Memory Test Aborted**

BIOS: ECC function has been disabled by BIOS. Go to Setup and enable ECC generation.

**Recoverable**

No

**Severity**

Warning

**Serviceable**

No

**Automatically notify support**

No

**User Response**

Complete the following steps:

1. Perform the actions mentioned one at a time and try the test after each action.
2. If the problem remains, contact your technical-service representative.
3. Turn off the system and disconnect it from power. Wait for 45 seconds. Reseat DIMM(s). Reconnect it to power.
4. Make sure that DSA and BIOS/uEFI are at the latest level.

**Related links**

- [IBM Support website](#)
- [Latest level of DSA](#)
- [Latest level of BMC/IMM](#)

- **201-827-003 : Standalone Memory Test Aborted**

BIOS: ECC function has been disabled by BIOS. Go to Setup and enable ECC generation.

**Recoverable**

No

**Severity**

Warning

**Serviceable**

No

**Automatically notify support**

No

**User Response**

Complete the following steps:

1. Perform the actions mentioned one at a time and try the test after each action.
2. If the problem remains, contact your technical-service representative.
3. Turn off the system and disconnect it from power. Wait for 45 seconds. Reseat DIMM(s). Reconnect it to power.
4. Make sure that DSA and BIOS/uEFI are at the latest level.

**Related links**

- [IBM Support website](#)
- [Latest level of DSA](#)
- [Latest level of BMC/IMM](#)

- **201-844-000 : Standalone Memory Test Aborted**

Chipset Error: Problem in masking MSR machine check control MASK registers.

**Recoverable**

No

**Severity**

Warning

**Serviceable**

No

**Automatically notify support**

No

**User Response**

Complete the following steps:



1. Perform the actions mentioned one at a time and try the test after each action.
2. If the problem remains, contact your technical-service representative.
3. Turn off the system and disconnect it from power. Wait for 45 seconds. Reseat DIMM(s). Reconnect it to power.
4. Make sure that DSA and BIOS/uEFI are at the latest level.

**Related links**

- [IBM Support website](#)
- [Latest level of DSA](#)
- [Latest level of BMC/IMM](#)

- **201-844-001 : Standalone Memory Test Aborted**

Chipset Error: Problem in masking MSR machine check control MASK registers.

**Recoverable**

No

**Severity**

Warning

**Serviceable**

No

**Automatically notify support**

No

**User Response**

Complete the following steps:

1. Perform the actions mentioned one at a time and try the test after each action.
2. If the problem remains, contact your technical-service representative.
3. Turn off the system and disconnect it from power. Wait for 45 seconds. Reseat DIMM(s). Reconnect it to power.
4. Make sure that DSA and BIOS/uEFI are at the latest level.

**Related links**

- [IBM Support website](#)
- [Latest level of DSA](#)
- [Latest level of BMC/IMM](#)

- **201-844-002 : Standalone Memory Test Aborted**

Chipset Error: Problem in masking MSR machine check control MASK registers.

**Recoverable**

No

**Severity**

Warning

**Serviceable**

No

**Automatically notify support**

No

**User Response**

Complete the following steps:

1. Perform the actions mentioned one at a time and try the test after each action.
2. If the problem remains, contact your technical-service representative.

3. Turn off the system and disconnect it from power. Wait for 45 seconds. Reseat DIMM(s). Reconnect it to power.
4. Make sure that DSA and BIOS/uEFI are at the latest level.

**Related links**

- [IBM Support website](#)
- [Latest level of DSA](#)
- [Latest level of BMC/IMM](#)

- **201-844-003 : Standalone Memory Test Aborted**

Chipset Error: Problem in masking MSR machine check control MASK registers.

**Recoverable**

No

**Severity**

Warning

**Serviceable**

No

**Automatically notify support**

No

**User Response**

Complete the following steps:

1. Perform the actions mentioned one at a time and try the test after each action.
2. If the problem remains, contact your technical-service representative.
3. Turn off the system and disconnect it from power. Wait for 45 seconds. Reseat DIMM(s). Reconnect it to power.
4. Make sure that DSA and BIOS/uEFI are at the latest level.

**Related links**

- [IBM Support website](#)
- [Latest level of DSA](#)
- [Latest level of BMC/IMM](#)

- **201-845-000 : Standalone Memory Test Aborted**

Chipset Error: Problem clearing MSR machine check control registers.

**Recoverable**

No

**Severity**

Warning

**Serviceable**

No

**Automatically notify support**

No

**User Response**

Complete the following steps:

1. Perform the actions mentioned one at a time and try the test after each action.
2. If the problem remains, contact your technical-service representative.
3. Turn off the system and disconnect it from power. Wait for 45 seconds. Reseat DIMM(s). Reconnect it to power.

4. Make sure that DSA and BIOS/uEFI are at the latest level.

**Related links**

- [IBM Support website](#)
- [Latest level of DSA](#)
- [Latest level of BMC/IMM](#)

- **201-845-001 : Standalone Memory Test Aborted**

Chipset Error: Problem clearing MSR machine check control registers.

**Recoverable**

No

**Severity**

Warning

**Serviceable**

No

**Automatically notify support**

No

**User Response**

Complete the following steps:

1. Perform the actions mentioned one at a time and try the test after each action.
2. If the problem remains, contact your technical-service representative.
3. Turn off the system and disconnect it from power. Wait for 45 seconds. Reseat DIMM(s). Reconnect it to power.
4. Make sure that DSA and BIOS/uEFI are at the latest level.

**Related links**

- [IBM Support website](#)
- [Latest level of DSA](#)
- [Latest level of BMC/IMM](#)

- **201-845-002 : Standalone Memory Test Aborted**

Chipset Error: Problem clearing MSR machine check control registers.

**Recoverable**

No

**Severity**

Warning

**Serviceable**

No

**Automatically notify support**

No

**User Response**

Complete the following steps:

1. Perform the actions mentioned one at a time and try the test after each action.
2. If the problem remains, contact your technical-service representative.
3. Turn off the system and disconnect it from power. Wait for 45 seconds. Reseat DIMM(s). Reconnect it to power.
4. Make sure that DSA and BIOS/uEFI are at the latest level.

**Related links**

- [IBM Support website](#)
- [Latest level of DSA](#)
- [Latest level of BMC/IMM](#)

- **201-845-003 : Standalone Memory Test Aborted**

Chipset Error: Problem clearing MSR machine check control registers.

**Recoverable**

No

**Severity**

Warning

**Serviceable**

No

**Automatically notify support**

No

**User Response**

Complete the following steps:

1. Perform the actions mentioned one at a time and try the test after each action.
2. If the problem remains, contact your technical-service representative.
3. Turn off the system and disconnect it from power. Wait for 45 seconds. Reseat DIMM(s). Reconnect it to power.
4. Make sure that DSA and BIOS/uEFI are at the latest level.

**Related links**

- [IBM Support website](#)
- [Latest level of DSA](#)
- [Latest level of BMC/IMM](#)

- **201-859-000 : Standalone Memory Test Aborted**

INVALID XSECSRAT type.

**Recoverable**

No

**Severity**

Warning

**Serviceable**

No

**Automatically notify support**

No

**User Response**

Complete the following steps:

1. Perform the actions mentioned one at a time and try the test after each action.
2. If the problem remains, contact your technical-service representative.
3. Turn off the system and disconnect it from power. Wait for 45 seconds. Reseat DIMM(s). Reconnect it to power.
4. Make sure that DSA and BIOS/uEFI are at the latest level.

**Related links**

- [IBM Support website](#)
- [Latest level of DSA](#)

- [Latest level of BMC/IMM](#)
- **201-859-001 : Standalone Memory Test Aborted**  
INVALID XSECSRAT type.

**Recoverable**

No

**Severity**

Warning

**Serviceable**

No

**Automatically notify support**

No

**User Response**

Complete the following steps:

1. Perform the actions mentioned one at a time and try the test after each action.
2. If the problem remains, contact your technical-service representative.
3. Turn off the system and disconnect it from power. Wait for 45 seconds. Reseat DIMM(s). Reconnect it to power.
4. Make sure that DSA and BIOS/uEFI are at the latest level.

**Related links**

- [IBM Support website](#)
- [Latest level of DSA](#)
- [Latest level of BMC/IMM](#)
- **201-859-002 : Standalone Memory Test Aborted**  
INVALID XSECSRAT type.

**Recoverable**

No

**Severity**

Warning

**Serviceable**

No

**Automatically notify support**

No

**User Response**

Complete the following steps:

1. Perform the actions mentioned one at a time and try the test after each action.
2. If the problem remains, contact your technical-service representative.
3. Turn off the system and disconnect it from power. Wait for 45 seconds. Reseat DIMM(s). Reconnect it to power.
4. Make sure that DSA and BIOS/uEFI are at the latest level.

**Related links**

- [IBM Support website](#)
- [Latest level of DSA](#)
- [Latest level of BMC/IMM](#)
- **201-859-003 : Standalone Memory Test Aborted**

INVALID XSECSRAT type.

**Recoverable**

No

**Severity**

Warning

**Serviceable**

No

**Automatically notify support**

No

**User Response**

Complete the following steps:

1. Perform the actions mentioned one at a time and try the test after each action.
2. If the problem remains, contact your technical-service representative.
3. Turn off the system and disconnect it from power. Wait for 45 seconds. Reseat DIMM(s). Reconnect it to power.
4. Make sure that DSA and BIOS/uEFI are at the latest level.

**Related links**

- [IBM Support website](#)
- [Latest level of DSA](#)
- [Latest level of BMC/IMM](#)

• **201-860-000 : Standalone Memory Test Aborted**

No OEM0 type 1 found.

**Recoverable**

No

**Severity**

Warning

**Serviceable**

No

**Automatically notify support**

No

**User Response**

Complete the following steps:

1. Perform the actions mentioned one at a time and try the test after each action.
2. If the problem remains, contact your technical-service representative.
3. Turn off the system and disconnect it from power. Wait for 45 seconds. Reseat DIMM(s). Reconnect it to power.
4. Make sure that DSA and BIOS/uEFI are at the latest level.

**Related links**

- [IBM Support website](#)
- [Latest level of DSA](#)
- [Latest level of BMC/IMM](#)

• **201-860-001 : Standalone Memory Test Aborted**

No OEM0 type 1 found.

**Recoverable**

No

**Severity**

Warning

**Serviceable**

No

**Automatically notify support**

No

**User Response**

Complete the following steps:

1. Perform the actions mentioned one at a time and try the test after each action.
2. If the problem remains, contact your technical-service representative.
3. Turn off the system and disconnect it from power. Wait for 45 seconds. Reseat DIMM(s). Reconnect it to power.
4. Make sure that DSA and BIOS/uEFI are at the latest level.

**Related links**

- [IBM Support website](#)
- [Latest level of DSA](#)
- [Latest level of BMC/IMM](#)

- **201-860-002 : Standalone Memory Test Aborted**

No OEM0 type 1 found.

**Recoverable**

No

**Severity**

Warning

**Serviceable**

No

**Automatically notify support**

No

**User Response**

Complete the following steps:

1. Perform the actions mentioned one at a time and try the test after each action.
2. If the problem remains, contact your technical-service representative.
3. Turn off the system and disconnect it from power. Wait for 45 seconds. Reseat DIMM(s). Reconnect it to power.
4. Make sure that DSA and BIOS/uEFI are at the latest level.

**Related links**

- [IBM Support website](#)
- [Latest level of DSA](#)
- [Latest level of BMC/IMM](#)

- **201-860-003 : Standalone Memory Test Aborted**

No OEM0 type 1 found.

**Recoverable**

No

**Severity**

Warning

**Serviceable**

No

**Automatically notify support**

No

**User Response**

Complete the following steps:

1. Perform the actions mentioned one at a time and try the test after each action.
2. If the problem remains, contact your technical-service representative.
3. Turn off the system and disconnect it from power. Wait for 45 seconds. Reseat DIMM(s). Reconnect it to power.
4. Make sure that DSA and BIOS/uEFI are at the latest level.

**Related links**

- [IBM Support website](#)
- [Latest level of DSA](#)
- [Latest level of BMC/IMM](#)

- **201-861-000 : Standalone Memory Test Aborted**

No SRAT type 1 found.

**Recoverable**

No

**Severity**

Warning

**Serviceable**

No

**Automatically notify support**

No

**User Response**

Complete the following steps:

1. Perform the actions mentioned one at a time and try the test after each action.
2. If the problem remains, contact your technical-service representative.
3. Turn off the system and disconnect it from power. Wait for 45 seconds. Reseat DIMM(s). Reconnect it to power.
4. Make sure that DSA and BIOS/uEFI are at the latest level.

**Related links**

- [IBM Support website](#)
- [Latest level of DSA](#)
- [Latest level of BMC/IMM](#)

- **201-861-001 : Standalone Memory Test Aborted**

No SRAT type 1 found.

**Recoverable**

No

**Severity**

Warning



**Serviceable**

No

**Automatically notify support**

No

**User Response**

Complete the following steps:

1. Perform the actions mentioned one at a time and try the test after each action.
2. If the problem remains, contact your technical-service representative.
3. Turn off the system and disconnect it from power. Wait for 45 seconds. Reseat DIMM(s). Reconnect it to power.
4. Make sure that DSA and BIOS/uEFI are at the latest level.

**Related links**

- [IBM Support website](#)
- [Latest level of DSA](#)
- [Latest level of BMC/IMM](#)

- **201-861-002 : Standalone Memory Test Aborted**

No SRAT type 1 found.

**Recoverable**

No

**Severity**

Warning

**Serviceable**

No

**Automatically notify support**

No

**User Response**

Complete the following steps:

1. Perform the actions mentioned one at a time and try the test after each action.
2. If the problem remains, contact your technical-service representative.
3. Turn off the system and disconnect it from power. Wait for 45 seconds. Reseat DIMM(s). Reconnect it to power.
4. Make sure that DSA and BIOS/uEFI are at the latest level.

**Related links**

- [IBM Support website](#)
- [Latest level of DSA](#)
- [Latest level of BMC/IMM](#)

- **201-861-003 : Standalone Memory Test Aborted**

No SRAT type 1 found.

**Recoverable**

No

**Severity**

Warning

**Serviceable**

No

**Automatically notify support**

No

**User Response**

Complete the following steps:

1. Perform the actions mentioned one at a time and try the test after each action.
2. If the problem remains, contact your technical-service representative.
3. Turn off the system and disconnect it from power. Wait for 45 seconds. Reseat DIMM(s). Reconnect it to power.
4. Make sure that DSA and BIOS/uEFI are at the latest level.

**Related links**

- [IBM Support website](#)
- [Latest level of DSA](#)
- [Latest level of BMC/IMM](#)

- **201-862-000 : Standalone Memory Test Aborted**

No OEM1 structure found.

**Recoverable**

No

**Severity**

Warning

**Serviceable**

No

**Automatically notify support**

No

**User Response**

Complete the following steps:

1. Perform the actions mentioned one at a time and try the test after each action.
2. If the problem remains, contact your technical-service representative.
3. Turn off the system and disconnect it from power. Wait for 45 seconds. Reseat DIMM(s). Reconnect it to power.
4. Make sure that DSA and BIOS/uEFI are at the latest level.

**Related links**

- [IBM Support website](#)
- [Latest level of DSA](#)
- [Latest level of BMC/IMM](#)

- **201-862-001 : Standalone Memory Test Aborted**

No OEM1 structure found.

**Recoverable**

No

**Severity**

Warning

**Serviceable**

No

**Automatically notify support**

No

**User Response**

Complete the following steps:

1. Perform the actions mentioned one at a time and try the test after each action.
2. If the problem remains, contact your technical-service representative.
3. Turn off the system and disconnect it from power. Wait for 45 seconds. Reseat DIMM(s). Reconnect it to power.
4. Make sure that DSA and BIOS/uEFI are at the latest level.

**Related links**

- [IBM Support website](#)
- [Latest level of DSA](#)
- [Latest level of BMC/IMM](#)

- **201-862-002 : Standalone Memory Test Aborted**

No OEM1 structure found.

**Recoverable**

No

**Severity**

Warning

**Serviceable**

No

**Automatically notify support**

No

**User Response**

Complete the following steps:

1. Perform the actions mentioned one at a time and try the test after each action.
2. If the problem remains, contact your technical-service representative.
3. Turn off the system and disconnect it from power. Wait for 45 seconds. Reseat DIMM(s). Reconnect it to power.
4. Make sure that DSA and BIOS/uEFI are at the latest level.

**Related links**

- [IBM Support website](#)
- [Latest level of DSA](#)
- [Latest level of BMC/IMM](#)

- **201-862-003 : Standalone Memory Test Aborted**

No OEM1 structure found.

**Recoverable**

No

**Severity**

Warning

**Serviceable**

No

**Automatically notify support**

No

**User Response**

Complete the following steps:

1. Perform the actions mentioned one at a time and try the test after each action.
2. If the problem remains, contact your technical-service representative.
3. Turn off the system and disconnect it from power. Wait for 45 seconds. Reseat DIMM(s). Reconnect it to power.
4. Make sure that DSA and BIOS/uEFI are at the latest level.

**Related links**

- [IBM Support website](#)
- [Latest level of DSA](#)
- [Latest level of BMC/IMM](#)

- **201-863-000 : Standalone Memory Test Aborted**

No IBMERROR key in OEM1 structure.

**Recoverable**

No

**Severity**

Warning

**Serviceable**

No

**Automatically notify support**

No

**User Response**

Complete the following steps:

1. Perform the actions mentioned one at a time and try the test after each action.
2. If the problem remains, contact your technical-service representative.
3. Turn off the system and disconnect it from power. Wait for 45 seconds. Reseat DIMM(s). Reconnect it to power.
4. Make sure that DSA and BIOS/uEFI are at the latest level.

**Related links**

- [IBM Support website](#)
- [Latest level of DSA](#)
- [Latest level of BMC/IMM](#)

- **201-863-001 : Standalone Memory Test Aborted**

No IBMERROR key in OEM1 structure.

**Recoverable**

No

**Severity**

Warning

**Serviceable**

No

**Automatically notify support**

No

**User Response**

Complete the following steps:

1. Perform the actions mentioned one at a time and try the test after each action.
2. If the problem remains, contact your technical-service representative.

3. Turn off the system and disconnect it from power. Wait for 45 seconds. Reseat DIMM(s). Reconnect it to power.
4. Make sure that DSA and BIOS/uEFI are at the latest level.

**Related links**

- [IBM Support website](#)
- [Latest level of DSA](#)
- [Latest level of BMC/IMM](#)

- **201-863-002 : Standalone Memory Test Aborted**

No IBMERROR key in OEM1 structure.

**Recoverable**

No

**Severity**

Warning

**Serviceable**

No

**Automatically notify support**

No

**User Response**

Complete the following steps:

1. Perform the actions mentioned one at a time and try the test after each action.
2. If the problem remains, contact your technical-service representative.
3. Turn off the system and disconnect it from power. Wait for 45 seconds. Reseat DIMM(s). Reconnect it to power.
4. Make sure that DSA and BIOS/uEFI are at the latest level.

**Related links**

- [IBM Support website](#)
- [Latest level of DSA](#)
- [Latest level of BMC/IMM](#)

- **201-863-003 : Standalone Memory Test Aborted**

No IBMERROR key in OEM1 structure.

**Recoverable**

No

**Severity**

Warning

**Serviceable**

No

**Automatically notify support**

No

**User Response**

Complete the following steps:

1. Perform the actions mentioned one at a time and try the test after each action.
2. If the problem remains, contact your technical-service representative.
3. Turn off the system and disconnect it from power. Wait for 45 seconds. Reseat DIMM(s). Reconnect it to power.

4. Make sure that DSA and BIOS/uEFI are at the latest level.

**Related links**

- [IBM Support website](#)
- [Latest level of DSA](#)
- [Latest level of BMC/IMM](#)

**• 201-864-000 : Standalone Memory Test Aborted**

No GAS located in OEM1.

**Recoverable**

No

**Severity**

Warning

**Serviceable**

No

**Automatically notify support**

No

**User Response**

Complete the following steps:

1. Perform the actions mentioned one at a time and try the test after each action.
2. If the problem remains, contact your technical-service representative.
3. Turn off the system and disconnect it from power. Wait for 45 seconds. Reseat DIMM(s). Reconnect it to power.
4. Make sure that DSA and BIOS/uEFI are at the latest level.

**Related links**

- [IBM Support website](#)
- [Latest level of DSA](#)
- [Latest level of BMC/IMM](#)

**• 201-864-001 : Standalone Memory Test Aborted**

No GAS located in OEM1.

**Recoverable**

No

**Severity**

Warning

**Serviceable**

No

**Automatically notify support**

No

**User Response**

Complete the following steps:

1. Perform the actions mentioned one at a time and try the test after each action.
2. If the problem remains, contact your technical-service representative.
3. Turn off the system and disconnect it from power. Wait for 45 seconds. Reseat DIMM(s). Reconnect it to power.
4. Make sure that DSA and BIOS/uEFI are at the latest level.

**Related links**

- [IBM Support website](#)
- [Latest level of DSA](#)
- [Latest level of BMC/IMM](#)

- **201-864-002 : Standalone Memory Test Aborted**

No GAS located in OEM1.

**Recoverable**

No

**Severity**

Warning

**Serviceable**

No

**Automatically notify support**

No

**User Response**

Complete the following steps:

1. Perform the actions mentioned one at a time and try the test after each action.
2. If the problem remains, contact your technical-service representative.
3. Turn off the system and disconnect it from power. Wait for 45 seconds. Reseat DIMM(s). Reconnect it to power.
4. Make sure that DSA and BIOS/uEFI are at the latest level.

**Related links**

- [IBM Support website](#)
- [Latest level of DSA](#)
- [Latest level of BMC/IMM](#)

- **201-864-003 : Standalone Memory Test Aborted**

No GAS located in OEM1.

**Recoverable**

No

**Severity**

Warning

**Serviceable**

No

**Automatically notify support**

No

**User Response**

Complete the following steps:

1. Perform the actions mentioned one at a time and try the test after each action.
2. If the problem remains, contact your technical-service representative.
3. Turn off the system and disconnect it from power. Wait for 45 seconds. Reseat DIMM(s). Reconnect it to power.
4. Make sure that DSA and BIOS/uEFI are at the latest level.

**Related links**

- [IBM Support website](#)
- [Latest level of DSA](#)

- [Latest level of BMC/IMM](#)
- **201-865-000 : Standalone Memory Test Aborted**

No XSECSRAT key in OEM0 structure.

**Recoverable**

No

**Severity**

Warning

**Serviceable**

No

**Automatically notify support**

No

**User Response**

Complete the following steps:

1. Perform the actions mentioned one at a time and try the test after each action.
2. If the problem remains, contact your technical-service representative.
3. Turn off the system and disconnect it from power. Wait for 45 seconds. Reseat DIMM(s). Reconnect it to power.
4. Make sure that DSA and BIOS/uEFI are at the latest level.

**Related links**

- [IBM Support website](#)
- [Latest level of DSA](#)
- [Latest level of BMC/IMM](#)

- **201-865-001 : Standalone Memory Test Aborted**

No XSECSRAT key in OEM0 structure.

**Recoverable**

No

**Severity**

Warning

**Serviceable**

No

**Automatically notify support**

No

**User Response**

Complete the following steps:

1. Perform the actions mentioned one at a time and try the test after each action.
2. If the problem remains, contact your technical-service representative.
3. Turn off the system and disconnect it from power. Wait for 45 seconds. Reseat DIMM(s). Reconnect it to power.
4. Make sure that DSA and BIOS/uEFI are at the latest level.

**Related links**

- [IBM Support website](#)
- [Latest level of DSA](#)
- [Latest level of BMC/IMM](#)

- **201-865-002 : Standalone Memory Test Aborted**



No XSECSRAT key in OEM0 structure.

**Recoverable**

No

**Severity**

Warning

**Serviceable**

No

**Automatically notify support**

No

**User Response**

Complete the following steps:

1. Perform the actions mentioned one at a time and try the test after each action.
2. If the problem remains, contact your technical-service representative.
3. Turn off the system and disconnect it from power. Wait for 45 seconds. Reseat DIMM(s). Reconnect it to power.
4. Make sure that DSA and BIOS/uEFI are at the latest level.

**Related links**

- [IBM Support website](#)
- [Latest level of DSA](#)
- [Latest level of BMC/IMM](#)

• **201-865-003 : Standalone Memory Test Aborted**

No XSECSRAT key in OEM0 structure.

**Recoverable**

No

**Severity**

Warning

**Serviceable**

No

**Automatically notify support**

No

**User Response**

Complete the following steps:

1. Perform the actions mentioned one at a time and try the test after each action.
2. If the problem remains, contact your technical-service representative.
3. Turn off the system and disconnect it from power. Wait for 45 seconds. Reseat DIMM(s). Reconnect it to power.
4. Make sure that DSA and BIOS/uEFI are at the latest level.

**Related links**

- [IBM Support website](#)
- [Latest level of DSA](#)
- [Latest level of BMC/IMM](#)

• **201-866-000 : Standalone Memory Test Aborted**

EFI-SAL Invalid parameter from GetMemoryMap function.

**Recoverable**

No

**Severity**

Warning

**Serviceable**

No

**Automatically notify support**

No

**User Response**

Complete the following steps:

1. Perform the actions mentioned one at a time and try the test after each action.
2. If the problem remains, contact your technical-service representative.
3. Turn off the system and disconnect it from power. Wait for 45 seconds. Reseat DIMM(s). Reconnect it to power.
4. Make sure that DSA and BIOS/uEFI are at the latest level.

**Related links**

- [IBM Support website](#)
- [Latest level of DSA](#)
- [Latest level of BMC/IMM](#)

- **201-866-001 : Standalone Memory Test Aborted**

EFI-SAL Invalid parameter from GetMemoryMap function.

**Recoverable**

No

**Severity**

Warning

**Serviceable**

No

**Automatically notify support**

No

**User Response**

Complete the following steps:

1. Perform the actions mentioned one at a time and try the test after each action.
2. If the problem remains, contact your technical-service representative.
3. Turn off the system and disconnect it from power. Wait for 45 seconds. Reseat DIMM(s). Reconnect it to power.
4. Make sure that DSA and BIOS/uEFI are at the latest level.

**Related links**

- [IBM Support website](#)
- [Latest level of DSA](#)
- [Latest level of BMC/IMM](#)

- **201-866-002 : Standalone Memory Test Aborted**

EFI-SAL Invalid parameter from GetMemoryMap function.

**Recoverable**

No

**Severity**

Warning

**Serviceable**

No

**Automatically notify support**

No

**User Response**

Complete the following steps:

1. Perform the actions mentioned one at a time and try the test after each action.
2. If the problem remains, contact your technical-service representative.
3. Turn off the system and disconnect it from power. Wait for 45 seconds. Reseat DIMM(s). Reconnect it to power.
4. Make sure that DSA and BIOS/uEFI are at the latest level.

**Related links**

- [IBM Support website](#)
- [Latest level of DSA](#)
- [Latest level of BMC/IMM](#)

- **201-866-003 : Standalone Memory Test Aborted**

EFI-SAL Invalid parameter from GetMemoryMap function.

**Recoverable**

No

**Severity**

Warning

**Serviceable**

No

**Automatically notify support**

No

**User Response**

Complete the following steps:

1. Perform the actions mentioned one at a time and try the test after each action.
2. If the problem remains, contact your technical-service representative.
3. Turn off the system and disconnect it from power. Wait for 45 seconds. Reseat DIMM(s). Reconnect it to power.
4. Make sure that DSA and BIOS/uEFI are at the latest level.

**Related links**

- [IBM Support website](#)
- [Latest level of DSA](#)
- [Latest level of BMC/IMM](#)

- **201-867-000 : Standalone Memory Test Aborted**

EFI/SAL: Buffer not allocated.

**Recoverable**

No

**Severity**

Warning

**Serviceable**

No

**Automatically notify support**

No

**User Response**

Complete the following steps:

1. Perform the actions mentioned one at a time and try the test after each action.
2. If the problem remains, contact your technical-service representative.
3. Turn off the system and disconnect it from power. Wait for 45 seconds. Reseat DIMM(s). Reconnect it to power.
4. Make sure that DSA and BIOS/uEFI are at the latest level.

**Related links**

- [IBM Support website](#)
- [Latest level of DSA](#)
- [Latest level of BMC/IMM](#)

- **201-867-001 : Standalone Memory Test Aborted**

EFI/SAL: Buffer not allocated.

**Recoverable**

No

**Severity**

Warning

**Serviceable**

No

**Automatically notify support**

No

**User Response**

Complete the following steps:

1. Perform the actions mentioned one at a time and try the test after each action.
2. If the problem remains, contact your technical-service representative.
3. Turn off the system and disconnect it from power. Wait for 45 seconds. Reseat DIMM(s). Reconnect it to power.
4. Make sure that DSA and BIOS/uEFI are at the latest level.

**Related links**

- [IBM Support website](#)
- [Latest level of DSA](#)
- [Latest level of BMC/IMM](#)

- **201-867-002 : Standalone Memory Test Aborted**

EFI/SAL: Buffer not allocated.

**Recoverable**

No

**Severity**

Warning

**Serviceable**

No

**Automatically notify support**

No

**User Response**

Complete the following steps:

1. Perform the actions mentioned one at a time and try the test after each action.
2. If the problem remains, contact your technical-service representative.
3. Turn off the system and disconnect it from power. Wait for 45 seconds. Reseat DIMM(s). Reconnect it to power.
4. Make sure that DSA and BIOS/uEFI are at the latest level.

**Related links**

- [IBM Support website](#)
- [Latest level of DSA](#)
- [Latest level of BMC/IMM](#)

- **201-867-003 : Standalone Memory Test Aborted**

EFI/SAL: Buffer not allocated.

**Recoverable**

No

**Severity**

Warning

**Serviceable**

No

**Automatically notify support**

No

**User Response**

Complete the following steps:

1. Perform the actions mentioned one at a time and try the test after each action.
2. If the problem remains, contact your technical-service representative.
3. Turn off the system and disconnect it from power. Wait for 45 seconds. Reseat DIMM(s). Reconnect it to power.
4. Make sure that DSA and BIOS/uEFI are at the latest level.

**Related links**

- [IBM Support website](#)
- [Latest level of DSA](#)
- [Latest level of BMC/IMM](#)

- **201-868-000 : Standalone Memory Test Aborted**

EFI/SAL: Buffer allocated in GetMemoryMap too small.

**Recoverable**

No

**Severity**

Warning

**Serviceable**

No

**Automatically notify support**

No

### User Response

Complete the following steps:

1. Perform the actions mentioned one at a time and try the test after each action.
2. If the problem remains, contact your technical-service representative.
3. Turn off the system and disconnect it from power. Wait for 45 seconds. Reseat DIMM(s). Reconnect it to power.
4. Make sure that DSA and BIOS/uEFI are at the latest level.

### Related links

- [IBM Support website](#)
- [Latest level of DSA](#)
- [Latest level of BMC/IMM](#)

- **201-868-001 : Standalone Memory Test Aborted**

EFI/SAL: Buffer allocated in GetMemoryMap too small.

### Recoverable

No

### Severity

Warning

### Serviceable

No

### Automatically notify support

No

### User Response

Complete the following steps:

1. Perform the actions mentioned one at a time and try the test after each action.
2. If the problem remains, contact your technical-service representative.
3. Turn off the system and disconnect it from power. Wait for 45 seconds. Reseat DIMM(s). Reconnect it to power.
4. Make sure that DSA and BIOS/uEFI are at the latest level.

### Related links

- [IBM Support website](#)
- [Latest level of DSA](#)
- [Latest level of BMC/IMM](#)

- **201-868-002 : Standalone Memory Test Aborted**

EFI/SAL: Buffer allocated in GetMemoryMap too small.

### Recoverable

No

### Severity

Warning

### Serviceable

No

### Automatically notify support

No

### User Response

Complete the following steps:

1. Perform the actions mentioned one at a time and try the test after each action.
2. If the problem remains, contact your technical-service representative.
3. Turn off the system and disconnect it from power. Wait for 45 seconds. Reseat DIMM(s). Reconnect it to power.
4. Make sure that DSA and BIOS/uEFI are at the latest level.

**Related links**

- [IBM Support website](#)
- [Latest level of DSA](#)
- [Latest level of BMC/IMM](#)

- **201-868-003 : Standalone Memory Test Aborted**

EFI/SAL: Buffer allocated in GetMemoryMap too small.

**Recoverable**

No

**Severity**

Warning

**Serviceable**

No

**Automatically notify support**

No

**User Response**

Complete the following steps:

1. Perform the actions mentioned one at a time and try the test after each action.
2. If the problem remains, contact your technical-service representative.
3. Turn off the system and disconnect it from power. Wait for 45 seconds. Reseat DIMM(s). Reconnect it to power.
4. Make sure that DSA and BIOS/uEFI are at the latest level.

**Related links**

- [IBM Support website](#)
- [Latest level of DSA](#)
- [Latest level of BMC/IMM](#)

- **201-869-000 : Standalone Memory Test Aborted**

EFI/SAL Invalid parameter from GetMemoryMap function.

**Recoverable**

No

**Severity**

Warning

**Serviceable**

No

**Automatically notify support**

No

**User Response**

Complete the following steps:

1. Perform the actions mentioned one at a time and try the test after each action.
2. If the problem remains, contact your technical-service representative.

3. Turn off the system and disconnect it from power. Wait for 45 seconds. Reseat DIMM(s). Reconnect it to power.
4. Make sure that DSA and BIOS/uEFI are at the latest level.

**Related links**

- [IBM Support website](#)
- [Latest level of DSA](#)
- [Latest level of BMC/IMM](#)

- **201-869-001 : Standalone Memory Test Aborted**

EFI/SAL Invalid parameter from GetMemoryMap function.

**Recoverable**

No

**Severity**

Warning

**Serviceable**

No

**Automatically notify support**

No

**User Response**

Complete the following steps:

1. Perform the actions mentioned one at a time and try the test after each action.
2. If the problem remains, contact your technical-service representative.
3. Turn off the system and disconnect it from power. Wait for 45 seconds. Reseat DIMM(s). Reconnect it to power.
4. Make sure that DSA and BIOS/uEFI are at the latest level.

**Related links**

- [IBM Support website](#)
- [Latest level of DSA](#)
- [Latest level of BMC/IMM](#)

- **201-869-002 : Standalone Memory Test Aborted**

EFI/SAL Invalid parameter from GetMemoryMap function.

**Recoverable**

No

**Severity**

Warning

**Serviceable**

No

**Automatically notify support**

No

**User Response**

Complete the following steps:

1. Perform the actions mentioned one at a time and try the test after each action.
2. If the problem remains, contact your technical-service representative.
3. Turn off the system and disconnect it from power. Wait for 45 seconds. Reseat DIMM(s). Reconnect it to power.



4. Make sure that DSA and BIOS/uEFI are at the latest level.

**Related links**

- [IBM Support website](#)
- [Latest level of DSA](#)
- [Latest level of BMC/IMM](#)

- **201-869-003 : Standalone Memory Test Aborted**

EFI/SAL Invalid parameter from GetMemoryMap function.

**Recoverable**

No

**Severity**

Warning

**Serviceable**

No

**Automatically notify support**

No

**User Response**

Complete the following steps:

1. Perform the actions mentioned one at a time and try the test after each action.
2. If the problem remains, contact your technical-service representative.
3. Turn off the system and disconnect it from power. Wait for 45 seconds. Reseat DIMM(s). Reconnect it to power.
4. Make sure that DSA and BIOS/uEFI are at the latest level.

**Related links**

- [IBM Support website](#)
- [Latest level of DSA](#)
- [Latest level of BMC/IMM](#)

- **201-870-000 : Standalone Memory Test Aborted**

CPU Doamin in ACPI not valid.

**Recoverable**

No

**Severity**

Warning

**Serviceable**

No

**Automatically notify support**

No

**User Response**

Complete the following steps:

1. Perform the actions mentioned one at a time and try the test after each action.
2. If the problem remains, contact your technical-service representative.
3. Turn off the system and disconnect it from power. Wait for 45 seconds. Reseat DIMM(s). Reconnect it to power.
4. Make sure that DSA and BIOS/uEFI are at the latest level.

**Related links**

- [IBM Support website](#)
- [Latest level of DSA](#)
- [Latest level of BMC/IMM](#)

- **201-870-001 : Standalone Memory Test Aborted**

CPU Doamin in ACPI not valid.

**Recoverable**

No

**Severity**

Warning

**Serviceable**

No

**Automatically notify support**

No

**User Response**

Complete the following steps:

1. Perform the actions mentioned one at a time and try the test after each action.
2. If the problem remains, contact your technical-service representative.
3. Turn off the system and disconnect it from power. Wait for 45 seconds. Reseat DIMM(s). Reconnect it to power.
4. Make sure that DSA and BIOS/uEFI are at the latest level.

**Related links**

- [IBM Support website](#)
- [Latest level of DSA](#)
- [Latest level of BMC/IMM](#)

- **201-870-002 : Standalone Memory Test Aborted**

CPU Doamin in ACPI not valid.

**Recoverable**

No

**Severity**

Warning

**Serviceable**

No

**Automatically notify support**

No

**User Response**

Complete the following steps:

1. Perform the actions mentioned one at a time and try the test after each action.
2. If the problem remains, contact your technical-service representative.
3. Turn off the system and disconnect it from power. Wait for 45 seconds. Reseat DIMM(s). Reconnect it to power.
4. Make sure that DSA and BIOS/uEFI are at the latest level.

**Related links**

- [IBM Support website](#)
- [Latest level of DSA](#)

- [Latest level of BMC/IMM](#)
- **201-870-003 : Standalone Memory Test Aborted**  
CPU Doamin in ACPI not valid.

**Recoverable**

No

**Severity**

Warning

**Serviceable**

No

**Automatically notify support**

No

**User Response**

Complete the following steps:

1. Perform the actions mentioned one at a time and try the test after each action.
2. If the problem remains, contact your technical-service representative.
3. Turn off the system and disconnect it from power. Wait for 45 seconds. Reseat DIMM(s). Reconnect it to power.
4. Make sure that DSA and BIOS/uEFI are at the latest level.

**Related links**

- [IBM Support website](#)
- [Latest level of DSA](#)
- [Latest level of BMC/IMM](#)
- **201-871-000 : Standalone Memory Test Aborted**  
Data Mis-compare encountered.

**Recoverable**

No

**Severity**

Warning

**Serviceable**

No

**Automatically notify support**

No

**User Response**

Complete the following steps:

1. Perform the actions mentioned one at a time and try the test after each action.
2. If the problem remains, contact your technical-service representative.
3. Turn off the system and disconnect it from power. Wait for 45 seconds. Reseat DIMM(s). Reconnect it to power.
4. Make sure that DSA and BIOS/uEFI are at the latest level.

**Related links**

- [IBM Support website](#)
- [Latest level of DSA](#)
- [Latest level of BMC/IMM](#)
- **201-871-001 : Standalone Memory Test Aborted**

Data Mis-compare encountered.

**Recoverable**

No

**Severity**

Warning

**Serviceable**

No

**Automatically notify support**

No

**User Response**

Complete the following steps:

1. Perform the actions mentioned one at a time and try the test after each action.
2. If the problem remains, contact your technical-service representative.
3. Turn off the system and disconnect it from power. Wait for 45 seconds. Reseat DIMM(s). Reconnect it to power.
4. Make sure that DSA and BIOS/uEFI are at the latest level.

**Related links**

- [IBM Support website](#)
- [Latest level of DSA](#)
- [Latest level of BMC/IMM](#)

• **201-871-002 : Standalone Memory Test Aborted**

Data Mis-compare encountered.

**Recoverable**

No

**Severity**

Warning

**Serviceable**

No

**Automatically notify support**

No

**User Response**

Complete the following steps:

1. Perform the actions mentioned one at a time and try the test after each action.
2. If the problem remains, contact your technical-service representative.
3. Turn off the system and disconnect it from power. Wait for 45 seconds. Reseat DIMM(s). Reconnect it to power.
4. Make sure that DSA and BIOS/uEFI are at the latest level.

**Related links**

- [IBM Support website](#)
- [Latest level of DSA](#)
- [Latest level of BMC/IMM](#)

• **201-871-003 : Standalone Memory Test Aborted**

Data Mis-compare encountered.

**Recoverable**

No

**Severity**

Warning

**Serviceable**

No

**Automatically notify support**

No

**User Response**

Complete the following steps:

1. Perform the actions mentioned one at a time and try the test after each action.
2. If the problem remains, contact your technical-service representative.
3. Turn off the system and disconnect it from power. Wait for 45 seconds. Reseat DIMM(s). Reconnect it to power.
4. Make sure that DSA and BIOS/uEFI are at the latest level.

**Related links**

- [IBM Support website](#)
- [Latest level of DSA](#)
- [Latest level of BMC/IMM](#)

- **201-877-000 : Standalone Memory Test Aborted**

BIOS: Sparing in Extended PCI reg. must be OFF. Go to setup and disable sparing.

**Recoverable**

No

**Severity**

Warning

**Serviceable**

No

**Automatically notify support**

No

**User Response**

Complete the following steps:

1. Perform the actions mentioned one at a time and try the test after each action.
2. If the problem remains, contact your technical-service representative.
3. Turn off the system and disconnect it from power. Wait for 45 seconds. Reseat DIMM(s). Reconnect it to power.
4. Make sure that DSA and BIOS/uEFI are at the latest level.

**Related links**

- [IBM Support website](#)
- [Latest level of DSA](#)
- [Latest level of BMC/IMM](#)

- **201-877-001 : Standalone Memory Test Aborted**

BIOS: Sparing in Extended PCI reg. must be OFF. Go to setup and disable sparing.

**Recoverable**

No

**Severity**

Warning

**Serviceable**

No

**Automatically notify support**

No

**User Response**

Complete the following steps:

1. Perform the actions mentioned one at a time and try the test after each action.
2. If the problem remains, contact your technical-service representative.
3. Turn off the system and disconnect it from power. Wait for 45 seconds. Reseat DIMM(s). Reconnect it to power.
4. Make sure that DSA and BIOS/uEFI are at the latest level.

**Related links**

- [IBM Support website](#)
- [Latest level of DSA](#)
- [Latest level of BMC/IMM](#)

- **201-877-002 : Standalone Memory Test Aborted**

BIOS: Sparing in Extended PCI reg. must be OFF. Go to setup and disable sparing.

**Recoverable**

No

**Severity**

Warning

**Serviceable**

No

**Automatically notify support**

No

**User Response**

Complete the following steps:

1. Perform the actions mentioned one at a time and try the test after each action.
2. If the problem remains, contact your technical-service representative.
3. Turn off the system and disconnect it from power. Wait for 45 seconds. Reseat DIMM(s). Reconnect it to power.
4. Make sure that DSA and BIOS/uEFI are at the latest level.

**Related links**

- [IBM Support website](#)
- [Latest level of DSA](#)
- [Latest level of BMC/IMM](#)

- **201-877-003 : Standalone Memory Test Aborted**

BIOS: Sparing in Extended PCI reg. must be OFF. Go to setup and disable sparing.

**Recoverable**

No

**Severity**

Warning

**Serviceable**

No

**Automatically notify support**

No

**User Response**

Complete the following steps:

1. Perform the actions mentioned one at a time and try the test after each action.
2. If the problem remains, contact your technical-service representative.
3. Turn off the system and disconnect it from power. Wait for 45 seconds. Reseat DIMM(s). Reconnect it to power.
4. Make sure that DSA and BIOS/uEFI are at the latest level.

**Related links**

- [IBM Support website](#)
- [Latest level of DSA](#)
- [Latest level of BMC/IMM](#)

- **201-878-000 : Standalone Memory Test Aborted**

Sparing feature must be turned OFF. Go to setup and turn the sparing feature OFF.

**Recoverable**

No

**Severity**

Warning

**Serviceable**

No

**Automatically notify support**

No

**User Response**

Complete the following steps:

1. Perform the actions mentioned one at a time and try the test after each action.
2. If the problem remains, contact your technical-service representative.
3. Turn off the system and disconnect it from power. Wait for 45 seconds. Reseat DIMM(s). Reconnect it to power.
4. Make sure that DSA and BIOS/uEFI are at the latest level.

**Related links**

- [IBM Support website](#)
- [Latest level of DSA](#)
- [Latest level of BMC/IMM](#)

- **201-878-001 : Standalone Memory Test Aborted**

Sparing feature must be turned OFF. Go to setup and turn the sparing feature OFF.

**Recoverable**

No

**Severity**

Warning

**Serviceable**

No

**Automatically notify support**

No

**User Response**

Complete the following steps:

1. Perform the actions mentioned one at a time and try the test after each action.
2. If the problem remains, contact your technical-service representative.
3. Turn off the system and disconnect it from power. Wait for 45 seconds. Reseat DIMM(s). Reconnect it to power.
4. Make sure that DSA and BIOS/uEFI are at the latest level.

**Related links**

- [IBM Support website](#)
- [Latest level of DSA](#)
- [Latest level of BMC/IMM](#)

- **201-878-002 : Standalone Memory Test Aborted**

Sparing feature must be turned OFF. Go to setup and turn the sparing feature OFF.

**Recoverable**

No

**Severity**

Warning

**Serviceable**

No

**Automatically notify support**

No

**User Response**

Complete the following steps:

1. Perform the actions mentioned one at a time and try the test after each action.
2. If the problem remains, contact your technical-service representative.
3. Turn off the system and disconnect it from power. Wait for 45 seconds. Reseat DIMM(s). Reconnect it to power.
4. Make sure that DSA and BIOS/uEFI are at the latest level.

**Related links**

- [IBM Support website](#)
- [Latest level of DSA](#)
- [Latest level of BMC/IMM](#)

- **201-878-003 : Standalone Memory Test Aborted**

Sparing feature must be turned OFF. Go to setup and turn the sparing feature OFF.

**Recoverable**

No

**Severity**

Warning

**Serviceable**

No

**Automatically notify support**

No



**User Response**

Complete the following steps:

1. Perform the actions mentioned one at a time and try the test after each action.
2. If the problem remains, contact your technical-service representative.
3. Turn off the system and disconnect it from power. Wait for 45 seconds. Reseat DIMM(s). Reconnect it to power.
4. Make sure that DSA and BIOS/uEFI are at the latest level.

**Related links**

- [IBM Support website](#)
- [Latest level of DSA](#)
- [Latest level of BMC/IMM](#)

- **201-885-000 : Standalone Memory Test Aborted**

Processor does not support MTRR register manipulation. Can not write to memory without cache.

**Recoverable**

No

**Severity**

Warning

**Serviceable**

No

**Automatically notify support**

No

**User Response**

Complete the following steps:

1. Perform the actions mentioned one at a time and try the test after each action.
2. If the problem remains, contact your technical-service representative.
3. Turn off the system and disconnect it from power. Wait for 45 seconds. Reseat DIMM(s). Reconnect it to power.
4. Make sure that DSA and BIOS/uEFI are at the latest level.

**Related links**

- [IBM Support website](#)
- [Latest level of DSA](#)
- [Latest level of BMC/IMM](#)

- **201-885-001 : Standalone Memory Test Aborted**

Processor does not support MTRR register manipulation. Can not write to memory without cache.

**Recoverable**

No

**Severity**

Warning

**Serviceable**

No

**Automatically notify support**

No

**User Response**

Complete the following steps:

1. Perform the actions mentioned one at a time and try the test after each action.
2. If the problem remains, contact your technical-service representative.
3. Turn off the system and disconnect it from power. Wait for 45 seconds. Reseat DIMM(s). Reconnect it to power.
4. Make sure that DSA and BIOS/uEFI are at the latest level.

**Related links**

- [IBM Support website](#)
- [Latest level of DSA](#)
- [Latest level of BMC/IMM](#)

**• 201-885-002 : Standalone Memory Test Aborted**

Processor does not support MTRR register manipulation. Can not write to memory without cache.

**Recoverable**

No

**Severity**

Warning

**Serviceable**

No

**Automatically notify support**

No

**User Response**

Complete the following steps:

1. Perform the actions mentioned one at a time and try the test after each action.
2. If the problem remains, contact your technical-service representative.
3. Turn off the system and disconnect it from power. Wait for 45 seconds. Reseat DIMM(s). Reconnect it to power.
4. Make sure that DSA and BIOS/uEFI are at the latest level.

**Related links**

- [IBM Support website](#)
- [Latest level of DSA](#)
- [Latest level of BMC/IMM](#)

**• 201-885-003 : Standalone Memory Test Aborted**

Processor does not support MTRR register manipulation. Can not write to memory without cache.

**Recoverable**

No

**Severity**

Warning

**Serviceable**

No

**Automatically notify support**

No

**User Response**

Complete the following steps:

1. Perform the actions mentioned one at a time and try the test after each action.
2. If the problem remains, contact your technical-service representative.

3. Turn off the system and disconnect it from power. Wait for 45 seconds. Reseat DIMM(s). Reconnect it to power.
4. Make sure that DSA and BIOS/uEFI are at the latest level.

**Related links**

- [IBM Support website](#)
- [Latest level of DSA](#)
- [Latest level of BMC/IMM](#)

- **201-886-000 : Standalone Memory Test Aborted**

Memory Upper limit is less than 16 Mbytes.

**Recoverable**

No

**Severity**

Warning

**Serviceable**

No

**Automatically notify support**

No

**User Response**

Complete the following steps:

1. Perform the actions mentioned one at a time and try the test after each action.
2. If the problem remains, contact your technical-service representative.
3. Turn off the system and disconnect it from power. Wait for 45 seconds. Reseat DIMM(s). Reconnect it to power.
4. Make sure that DSA and BIOS/uEFI are at the latest level.

**Related links**

- [IBM Support website](#)
- [Latest level of DSA](#)
- [Latest level of BMC/IMM](#)

- **201-886-001 : Standalone Memory Test Aborted**

Memory Upper limit is less than 16 Mbytes.

**Recoverable**

No

**Severity**

Warning

**Serviceable**

No

**Automatically notify support**

No

**User Response**

Complete the following steps:

1. Perform the actions mentioned one at a time and try the test after each action.
2. If the problem remains, contact your technical-service representative.
3. Turn off the system and disconnect it from power. Wait for 45 seconds. Reseat DIMM(s). Reconnect it to power.

4. Make sure that DSA and BIOS/uEFI are at the latest level.

**Related links**

- [IBM Support website](#)
- [Latest level of DSA](#)
- [Latest level of BMC/IMM](#)

- **201-886-002 : Standalone Memory Test Aborted**

Memory Upper limit is less than 16 Mbytes.

**Recoverable**

No

**Severity**

Warning

**Serviceable**

No

**Automatically notify support**

No

**User Response**

Complete the following steps:

1. Perform the actions mentioned one at a time and try the test after each action.
2. If the problem remains, contact your technical-service representative.
3. Turn off the system and disconnect it from power. Wait for 45 seconds. Reseat DIMM(s).  
Reconnect it to power.
4. Make sure that DSA and BIOS/uEFI are at the latest level.

**Related links**

- [IBM Support website](#)
- [Latest level of DSA](#)
- [Latest level of BMC/IMM](#)

- **201-886-003 : Standalone Memory Test Aborted**

Memory Upper limit is less than 16 Mbytes.

**Recoverable**

No

**Severity**

Warning

**Serviceable**

No

**Automatically notify support**

No

**User Response**

Complete the following steps:

1. Perform the actions mentioned one at a time and try the test after each action.
2. If the problem remains, contact your technical-service representative.
3. Turn off the system and disconnect it from power. Wait for 45 seconds. Reseat DIMM(s).  
Reconnect it to power.
4. Make sure that DSA and BIOS/uEFI are at the latest level.

**Related links**

- [IBM Support website](#)
- [Latest level of DSA](#)
- [Latest level of BMC/IMM](#)

- **201-899-000 : Standalone Memory Test Aborted**

Memory Diagnostics Test Aborted by user.

**Recoverable**

No

**Severity**

Warning

**Serviceable**

No

**Automatically notify support**

No

**Related links**

- [IBM Support website](#)
- [Latest level of DSA](#)
- [Latest level of BMC/IMM](#)

- **201-899-001 : Standalone Memory Test Aborted**

Memory Diagnostics Test Aborted by user.

**Recoverable**

No

**Severity**

Warning

**Serviceable**

No

**Automatically notify support**

No

**Related links**

- [IBM Support website](#)
- [Latest level of DSA](#)
- [Latest level of BMC/IMM](#)

- **201-899-002 : Standalone Memory Test Aborted**

Memory Diagnostics Test Aborted by user.

**Recoverable**

No

**Severity**

Warning

**Serviceable**

No

**Automatically notify support**

No

**Related links**

- [IBM Support website](#)
- [Latest level of DSA](#)
- [Latest level of BMC/IMM](#)

- **201-899-003 : Standalone Memory Test Aborted**

Memory Diagnostics Test Aborted by user.

**Recoverable**

No

**Severity**

Warning

**Serviceable**

No

**Automatically notify support**

No

**Related links**

- [IBM Support website](#)
- [Latest level of DSA](#)
- [Latest level of BMC/IMM](#)

- **201-901-000 : Standalone Memory Test Failed**

Memory Diagnostics Test Failed.

**Recoverable**

No

**Severity**

Error

**Serviceable**

Yes

**Automatically notify support**

No

**User Response**

Complete the following steps:

1. Perform the actions mentioned one at a time and try the test after each action.
2. If the problem remains, contact your technical-service representative.
3. Turn off the system and disconnect it from power. Wait for 45 seconds. Reseat DIMM(s). Reconnect it to power.
4. Make sure that DSA and BIOS/uEFI are at the latest level.
5. Replace any DIMMS(s) mentioned in error, one by one.
6. Make sure that all DIMMs are enabled in the Configuration/Setup Utility program.
7. If failure remains, refer to "Troubleshooting by symptom" in the system "Installation and Service Guide" for the next corrective action.

**Related links**

- [IBM Support website](#)
- [Latest level of DSA](#)
- [Latest level of BMC/IMM](#)

- **201-901-001 : Standalone Memory Test Failed**

Memory Diagnostics Test Failed.

**Recoverable**

No

**Severity**

Error

**Serviceable**

Yes

**Automatically notify support**

No

**User Response**

Complete the following steps:

1. Perform the actions mentioned one at a time and try the test after each action.
2. If the problem remains, contact your technical-service representative.
3. Turn off the system and disconnect it from power. Wait for 45 seconds. Reseat DIMM(s). Reconnect it to power.
4. Make sure that DSA and BIOS/uEFI are at the latest level.
5. Replace any DIMMS(s) mentioned in error, one by one.
6. Make sure that all DIMMs are enabled in the Configuration/Setup Utility program.
7. If failure remains, refer to "Troubleshooting by symptom" in the system "Installation and Service Guide" for the next corrective action.

**Related links**

- [IBM Support website](#)
- [Latest level of DSA](#)
- [Latest level of BMC/IMM](#)

- **201-901-002 : Standalone Memory Test Failed**

Memory Diagnostics Test Failed.

**Recoverable**

No

**Severity**

Error

**Serviceable**

Yes

**Automatically notify support**

No

**User Response**

Complete the following steps:

1. Perform the actions mentioned one at a time and try the test after each action.
2. If the problem remains, contact your technical-service representative.
3. Turn off the system and disconnect it from power. Wait for 45 seconds. Reseat DIMM(s). Reconnect it to power.
4. Make sure that DSA and BIOS/uEFI are at the latest level.
5. Replace any DIMMS(s) mentioned in error, one by one.
6. Make sure that all DIMMs are enabled in the Configuration/Setup Utility program.
7. If failure remains, refer to "Troubleshooting by symptom" in the system "Installation and Service Guide" for the next corrective action.

**Related links**

- [IBM Support website](#)

- [Latest level of DSA](#)
- [Latest level of BMC/IMM](#)
- **201-901-003 : Standalone Memory Test Failed**

Memory Diagnostics Test Failed.

**Recoverable**

No

**Severity**

Error

**Serviceable**

Yes

**Automatically notify support**

No

**User Response**

Complete the following steps:

1. Perform the actions mentioned one at a time and try the test after each action.
2. If the problem remains, contact your technical-service representative.
3. Turn off the system and disconnect it from power. Wait for 45 seconds. Reseat DIMM(s). Reconnect it to power.
4. Make sure that DSA and BIOS/uEFI are at the latest level.
5. Replace any DIMMS(s) mentioned in error, one by one.
6. Make sure that all DIMMs are enabled in the Configuration/Setup Utility program.
7. If failure remains, refer to "Troubleshooting by symptom" in the system "Installation and Service Guide" for the next corrective action.

**Related links**

- [IBM Support website](#)
- [Latest level of DSA](#)
- [Latest level of BMC/IMM](#)

## **DSA optical drive test results**

The following messages can result when you run the optical drive test.

### **Test results for the DSA optical drive test**

The following messages can result when you run the DSA optical drive test.

- **215-000-000 : Optical Drive Test Passed**

Optical Drive Test Passed.

**Recoverable**

No

**Severity**

Event

**Serviceable**

No

**Automatically notify support**

No

**Related links**



- [IBM Support website](#)
- [Latest level of DSA](#)
- [Latest level of BMC/IMM](#)

- **215-801-000 : Optical Drive Test Aborted**

Optical Drive Test Aborted. Unable to communicate with driver.

**Recoverable**

No

**Severity**

Warning

**Serviceable**

Yes

**Automatically notify support**

No

**User Response**

Complete the following steps:

1. Make sure that the DSA Diagnostic code is at the latest level.
2. Run the test again.
3. Check the drive cabling for loose or broken connections at both ends or damage to the cable. Replace the cable if damage is present.
4. Run the test again.
5. Check system firmware level and upgrade if necessary. The installed firmware level can be found in the DSA Diagnostic Event Log within the Firmware/VPD section for this component.
6. Run the test again.

**Related links**

- [IBM Support website](#)
- [Latest level of DSA](#)
- [Latest level of BMC/IMM](#)

- **215-802-000 : Optical Drive Test Aborted**

Optical Drive Test Aborted. A read error was encountered.

**Recoverable**

No

**Severity**

Warning

**Serviceable**

Yes

**Automatically notify support**

No

**User Response**

Complete the following steps:

1. Insert a new CD or DVD into the drive and wait for 15 seconds for the media to be recognized. Rerun the test.
2. Check the drive cabling for loose or broken connections at both ends or damage to the cable. Replace the cable if damage is present.
3. Run the test again.

4. If failure remains, refer to "Troubleshooting by symptom" in the system "Installation and Service Guide" for the next corrective action.

**Related links**

- [IBM Support website](#)
- [Latest level of DSA](#)
- [Latest level of BMC/IMM](#)

- **215-803-000 : Optical Drive Test Failed**

Optical Drive Test Failed. Disk may be in use by the operating system.

**Recoverable**

No

**Severity**

Error

**Serviceable**

Yes

**Automatically notify support**

No

**User Response**

Complete the following steps:

1. Wait for the system activity to cease
2. Run the test again
3. Turn off and restart the system.
4. Run the test again.

**Related links**

- [IBM Support website](#)
- [Latest level of DSA](#)
- [Latest level of BMC/IMM](#)

- **215-804-000 : Optical Drive Test Aborted**

Optical Drive Test Aborted. The media tray is open.

**Recoverable**

No

**Severity**

Warning

**Serviceable**

Yes

**Automatically notify support**

No

**User Response**

Complete the following steps:

1. Close the media tray and wait for 15 seconds for the media to be recognized. Run the test again.
2. Insert a new CD or DVD into the drive and wait for 15 seconds for the media to be recognized. Rerun the test.
3. Check the drive cabling for loose or broken connections at both ends or damage to the cable. Replace the cable if damage is present.
4. Run the test again.

5. If failure remains, refer to "Troubleshooting by symptom" in the system "Installation and Service Guide" for the next corrective action.

**Related links**

- [IBM Support website](#)
- [Latest level of DSA](#)
- [Latest level of BMC/IMM](#)

- **215-901-000 : Optical Drive Test Aborted**

Optical Drive Test Aborted. Drive media is not detected.

**Recoverable**

No

**Severity**

Warning

**Serviceable**

Yes

**Automatically notify support**

No

**User Response**

Complete the following steps:

1. Insert a new CD or DVD into the drive and wait for 15 seconds for the media to be recognized. Rerun the test.
2. Check the drive cabling for loose or broken connections at both ends or damage to the cable. Replace the cable if damage is present.
3. Run the test again.
4. If failure remains, refer to "Troubleshooting by symptom" in the system "Installation and Service Guide" for the next corrective action.

**Related links**

- [IBM Support website](#)
- [Latest level of DSA](#)
- [Latest level of BMC/IMM](#)

- **215-902-000 : Optical Drive Test Failed**

Optical Drive Test Failed. Read miscompare.

**Recoverable**

No

**Severity**

Error

**Serviceable**

Yes

**Automatically notify support**

No

**User Response**

Complete the following steps:

1. Insert a new CD or DVD into the drive and wait for 15 seconds for the media to be recognized. Rerun the test.
2. Check the drive cabling for loose or broken connections at both ends or damage to the cable. Replace the cable if damage is present.

3. Run the test again.
4. If failure remains, refer to "Troubleshooting by symptom" in the system "Installation and Service Guide" for the next corrective action.

**Related links**

- [IBM Support website](#)
- [Latest level of DSA](#)
- [Latest level of BMC/IMM](#)

**• 215-903-000 : Optical Drive Test Aborted**

Optical Drive Test Aborted. Could not access the device.

**Recoverable**

No

**Severity**

Warning

**Serviceable**

Yes

**Automatically notify support**

No

**User Response**

Complete the following steps:

1. Insert a new CD or DVD into the drive and wait for 15 seconds for the media to be recognized. Rerun the test.
2. Check the drive cabling for loose or broken connections at both ends or damage to the cable. Replace the cable if damage is present.
3. Run the test again.
4. Check system firmware level and upgrade if necessary. The installed firmware level can be found in the DSA Diagnostic Event Log within the Firmware/VPD section for this component.
5. Run the test again.
6. If failure remains, refer to "Troubleshooting by symptom" in the system "Installation and Service Guide" for the next corrective action.

**Related links**

- [IBM Support website](#)
- [Latest level of DSA](#)
- [Latest level of BMC/IMM](#)

**DSA tape drive test results**

The following messages can result when you run the tape drive test.

**Test results for the DSA tape drive test**

The following messages can result when you run the DSA tape drive test.

**• 264-000-000 : Tape Test Passed**

Tape Test Passed.

**Recoverable**

No

**Severity**

Event

**Serviceable**

No

**Automatically notify support**

No

**Related links**

- [IBM Support website](#)
- [Latest level of DSA](#)
- [Latest level of BMC/IMM](#)

- **264-901-000 : Tape Test Failed**

An error was found in the tape alert log.

**Recoverable**

No

**Severity**

Error

**Serviceable**

Yes

**Automatically notify support**

No

**User Response**

Complete the following steps:

1. Clean the tape drive using the appropriate cleaning media and install new media.
2. Run the test again.
3. Clear the error log.
4. Run the test again.
5. Make sure that the drive firmware is at the latest level.
6. Rerun the test after upgrading to the latest firmware level.
7. If the failure remains, refer to "Troubleshooting by symptom" in the system "Installation and Service Guide" for the next corrective action.

**Related links**

- [IBM Support website](#)
- [Latest level of DSA](#)
- [Latest level of BMC/IMM](#)

- **264-902-000 : Tape Test Failed**

Tape Test Failed. Media is not detected.

**Recoverable**

No

**Severity**

Error

**Serviceable**

Yes

**Automatically notify support**

No

**User Response**

Complete the following steps:

1. Clean the tape drive using the appropriate cleaning media and install new media.
2. Run the test again.
3. Make sure that the drive firmware is at the latest level.
4. Rerun the test after upgrading to the latest firmware level.
5. If the failure remains, refer to "Troubleshooting by symptom" in the system "Installation and Service Guide" for the next corrective action.

**Related links**

- [IBM Support website](#)
- [Latest level of DSA](#)
- [Latest level of BMC/IMM](#)

- **264-903-000 : Tape Test Failed**

Tape Test Failed. Media is not detected.

**Recoverable**

No

**Severity**

Error

**Serviceable**

Yes

**Automatically notify support**

No

**User Response**

Complete the following steps:

1. Clean the tape drive using the appropriate cleaning media and install new media.
2. Run the test again.
3. Make sure that the drive firmware is at the latest level.
4. Rerun the test after upgrading to the latest firmware level.
5. If the failure remains, refer to "Troubleshooting by symptom" in the system "Installation and Service Guide" for the next corrective action.

**Related links**

- [IBM Support website](#)
- [Latest level of DSA](#)
- [Latest level of BMC/IMM](#)

- **264-904-000 : Tape Test Failed**

Tape Test Failed. Drive hardware error.

**Recoverable**

No

**Severity**

Error

**Serviceable**

Yes

**Automatically notify support**

No

**User Response**

Complete the following steps:

1. Check the tape drive cabling for loose or broken connections or damage to the cable. Replace the cable if damage is present.
2. Clean the tape drive using the appropriate cleaning media and install new media.
3. Run the test again.
4. Make sure that the drive firmware is at the latest level.
5. Rerun the test after upgrading to the latest firmware level.
6. If the failure remains, refer to "Troubleshooting by symptom" in the system "Installation and Service Guide" for the next corrective action.

**Related links**

- [IBM Support website](#)
- [Latest level of DSA](#)
- [Latest level of BMC/IMM](#)

**• 264-905-000 : Tape Test Failed**

Tape Test Failed. Software error: invalid request.

**Recoverable**

No

**Severity**

Error

**Serviceable**

Yes

**Automatically notify support**

No

**User Response**

Complete the following steps:

1. If the system has stopped responding, turn off and restart the system.
2. Check the system firmware level and upgrade if necessary. The installed firmware level can be found in the DSA Diagnostic Event Log within the Firmware/VPD section for this component.
3. Run the test again.
4. If the system has stopped responding, turn off and restart the system.
5. Make sure that the drive firmware is at the latest level.
6. Run the test again.
7. If the failure remains, refer to "Troubleshooting by symptom" in the system "Installation and Service Guide" for the next corrective action.

**Related links**

- [IBM Support website](#)
- [Latest level of DSA](#)
- [Latest level of BMC/IMM](#)

**• 264-906-000 : Tape Test Failed**

Tape Test Failed. Unrecognized error.

**Recoverable**

No

**Severity**

Error

**Serviceable**

Yes

**Automatically notify support**

No

**User Response**

Complete the following steps:

1. Clean the tape drive using the appropriate cleaning media and install new media.
2. Run the test again.
3. Make sure that the drive firmware is at the latest level.
4. Rerun the test after upgrading to the latest firmware level.
5. Make sure that the DSA Diagnostic code is at the latest level.
6. Run the test again.
7. Check the system firmware level and upgrade if necessary.
8. Run the test again.
9. If the failure remains, refer to "Troubleshooting by symptom" in the system "Installation and Service Guide" for the next corrective action.

**Related links**

- [IBM Support website](#)
- [Latest level of DSA](#)
- [Latest level of BMC/IMM](#)

• **264-907-000 : Tape Test Failed**

An error was found in the block address somewhere.

**Recoverable**

No

**Severity**

Error

**Serviceable**

Yes

**Automatically notify support**

No

**User Response**

Complete the following steps:

1. Clean the tape drive using the appropriate cleaning media and install new media.

**Related links**

- [IBM Support website](#)
- [Latest level of DSA](#)
- [Latest level of BMC/IMM](#)

• **264-908-000 : Tape Test Failed**

An error was found in getting tape capacity.

**Recoverable**

No

**Severity**

Error

**Serviceable**

Yes



**Automatically notify support**

No

**User Response**

Complete the following steps:

1. Make sure that medium is present.
2. Clean the tape drive using the appropriate cleaning media and install new media.

**Related links**

- [IBM Support website](#)
- [Latest level of DSA](#)
- [Latest level of BMC/IMM](#)

**DSA hard drive test results**

The following messages can result when you run the hard drive test.

**Test results for the DSA hard drive test**

The following messages can result when you run the DSA hard drive test.

- **217-000-000 : HDD Test Passed**

HDD Stress Test Passed.

**Recoverable**

No

**Severity**

Event

**Serviceable**

No

**Automatically notify support**

No

**Related links**

- [IBM Support website](#)
- [Latest level of DSA](#)
- [Latest level of BMC/IMM](#)

- **217-800-000 : HDD Test Aborted**

HDD Test Aborted. The test was canceled.

**Recoverable**

No

**Severity**

Warning

**Serviceable**

Yes

**Automatically notify support**

No

**User Response**

Complete the following steps:

1. Check cable connections.
2. Rerun the test.

3. Verify that Hard drive supports self test and self test logging.
4. If the problem remains, contact your technical-support representative.

**Related links**

- [IBM Support website](#)
- [Latest level of DSA](#)
- [Latest level of BMC/IMM](#)

**• 217-900-000 : HDD Test Failed**

HDD Test Failed. The hard drive self-test detected a failure.

**Recoverable**

No

**Severity**

Error

**Serviceable**

Yes

**Automatically notify support**

No

**User Response**

Complete the following steps:

1. Check cable connections.
2. Rerun the test.
3. Verify the firmware is at the latest level.
4. Rerun the test.
5. If the problem remains, contact your technical-support representative.

**Related links**

- [IBM Support website](#)
- [Latest level of DSA](#)
- [Latest level of BMC/IMM](#)

**DSA LSI hard drive test results**

The following messages can result when you run the LSI hard drive test.

**Test results for the DSA LSI hard driveoutputfilename=DSA\_LSI\_hard\_drive test**

The following messages can result when you run the DSA LSI hard driveoutputfilename=DSA\_LSI\_hard\_drive test.

**• 407-000-000 : LSIESG:DiskDefaultDiagnostic Test Passed**

The test passed.

**Recoverable**

No

**Severity**

Event

**Serviceable**

No

**Automatically notify support**

No

**Related links**

- [IBM Support website](#)
- [Latest level of DSA](#)
- [Latest level of BMC/IMM](#)

- **407-800-000 : LSIESG:DiskDefaultDiagnostic Test Aborted**

The test was canceled.

**Recoverable**

No

**Severity**

Warning

**Serviceable**

No

**Automatically notify support**

No

**Related links**

- [IBM Support website](#)
- [Latest level of DSA](#)
- [Latest level of BMC/IMM](#)

- **407-900-000 : LSIESG:DiskDefaultDiagnostic Test Failed**

The hard drive self-test detected a failure.

**Recoverable**

No

**Severity**

Error

**Serviceable**

Yes

**Automatically notify support**

No

**User Response**

Complete the following steps:

1. Check cable connections.
2. Rerun the test.
3. Verify whether the firmware is at the latest level.
4. Rerun the test.
5. If the problem remains, contact your IBM technical-support representative.

**Related links**

- [IBM Support website](#)
- [Latest level of DSA](#)
- [Latest level of BMC/IMM](#)

**DSA Nvidia GPU test results**

The following messages can result when you run the Nvidia GPU test.

**Test results for the DSA Nvidia GPU test**

The following messages can result when you run the DSA Nvidia GPU test.

- **409-000-000 : NVIDIA User Diagnostic Test Passed**

NVIDIA User Diagnostic test passed.

**Recoverable**

No

**Severity**

Event

**Serviceable**

No

**Automatically notify support**

No

**Related links**

- [IBM Support website](#)
- [Latest level of DSA](#)
- [Latest level of BMC/IMM](#)

- **409-003-000 : Nvidia::DiagnosticServiceProvider::Bandwidth Test Passed**

Nvidia GPU Bandwidth test passed.

**Recoverable**

No

**Severity**

Event

**Serviceable**

No

**Automatically notify support**

No

**Related links**

- [IBM Support website](#)
- [Latest level of DSA](#)
- [Latest level of BMC/IMM](#)

- **409-004-000 : Nvidia::DiagnosticServiceProvider::Query Test Passed**

Nvidia GPU Query test passed.

**Recoverable**

No

**Severity**

Event

**Serviceable**

No

**Automatically notify support**

No

**Related links**

- [IBM Support website](#)
- [Latest level of DSA](#)
- [Latest level of BMC/IMM](#)

- **409-005-000 : Nvidia::DiagnosticServiceProvider::Matrix Test Passed**

Nvidia GPU Matrix test passed.

**Recoverable**

No

**Severity**

Event

**Serviceable**

No

**Automatically notify support**

No

**Related links**

- [IBM Support website](#)
- [Latest level of DSA](#)
- [Latest level of BMC/IMM](#)

- **409-006-000 : Nvidia::DiagnosticServiceProvider::Binomial Test Passed**

Nvidia GPU Binomial test passed.

**Recoverable**

No

**Severity**

Event

**Serviceable**

No

**Automatically notify support**

No

**Related links**

- [IBM Support website](#)
- [Latest level of DSA](#)
- [Latest level of BMC/IMM](#)

- **409-800-000 : NVIDIA User Diagnostic Test Aborted**

NVIDIA User Diagnostic test was canceled.

**Recoverable**

No

**Severity**

Event

**Serviceable**

No

**Automatically notify support**

No

**Related links**

- [IBM Support website](#)
- [Latest level of DSA](#)
- [Latest level of BMC/IMM](#)

- **409-803-000 : Nvidia::DiagnosticServiceProvider::Bandwidth Test Aborted**

Nvidia GPU Bandwidth test was canceled.

**Recoverable**

No

**Severity**

Warning

**Serviceable**

No

**Automatically notify support**

No

**Related links**

- [IBM Support website](#)
- [Latest level of DSA](#)
- [Latest level of BMC/IMM](#)

- **409-804-000 : Nvidia::DiagnosticServiceProvider::Query Test Aborted**

Nvidia GPU Query test was canceled.

**Recoverable**

No

**Severity**

Warning

**Serviceable**

No

**Automatically notify support**

No

**Related links**

- [IBM Support website](#)
- [Latest level of DSA](#)
- [Latest level of BMC/IMM](#)

- **409-805-000 : Nvidia::DiagnosticServiceProvider::Matrix Test Aborted**

Nvidia GPU Matrix test was canceled.

**Recoverable**

No

**Severity**

Warning

**Serviceable**

No

**Automatically notify support**

No

**Related links**

- [IBM Support website](#)
- [Latest level of DSA](#)
- [Latest level of BMC/IMM](#)

- **409-806-000 : Nvidia::DiagnosticServiceProvider::Binomial Test Aborted**

Nvidia GPU Binomial test was canceled.

**Recoverable**

No

**Severity**

Warning

**Serviceable**

No

**Automatically notify support**

No

**Related links**

- [IBM Support website](#)
- [Latest level of DSA](#)
- [Latest level of BMC/IMM](#)

- **409-900-000 : NVIDIA User Diagnostic Test Failed**

NVIDIA User Diagnostic Test Failed.

**Recoverable**

No

**Severity**

Event

**Serviceable**

Yes

**Automatically notify support**

No

**User Response**

Complete the following steps:

1. Verify that the GPU is seated in the PCIe slot correctly by reseating the GPU. Then power cycle the system.
2. Verify that the power connectors to the GPU are connected firmly. Then power cycle the system.
3. Run nvidia-smi -q In some cases this will report a poorly connected power cable.
4. Rerun the diagnostics, using the same GPU, on system that is known to be working. A variety of system issues can cause diagnostic failure.
5. If the problem remains, contact your IBM technical-support representative.

**Related links**

- [IBM Support website](#)
- [Latest level of DSA](#)
- [Latest level of BMC/IMM](#)

- **409-903-000 : Nvidia::DiagnosticServiceProvider::Bandwidth Test Failed**

Nvidia GPU Bandwidth Test Failed.

**Recoverable**

No

**Severity**

Error

**Serviceable**

Yes

**Automatically notify support**

No

**User Response**

Complete the following steps:

1. Verify that the GPU is seated in the PCIe slot correctly by reseating the GPU. Then power cycle the system.
2. Verify that the power connectors to the GPU are connected firmly. Then power cycle the system.
3. Run `nvidia-smi -q` In some cases this will report a poorly connected power cable.
4. Rerun the diagnostics, using the same GPU, on system that is known to be working. A variety of system issues can cause diagnostic failure.
5. If the problem remains, contact your IBM technical-support representative.

**Related links**

- [IBM Support website](#)
- [Latest level of DSA](#)
- [Latest level of BMC/IMM](#)

- **409-904-000 : Nvidia::DiagnosticServiceProvider::Query Test Failed**

Nvidia GPU Query Test Failed.

**Recoverable**

No

**Severity**

Error

**Serviceable**

Yes

**Automatically notify support**

No

**User Response**

Complete the following steps:

1. Verify that the GPU is seated in the PCIe slot correctly by reseating the GPU. Then power cycle the system.
2. Verify that the power connectors to the GPU are connected firmly. Then power cycle the system.
3. Run `nvidia-smi -q` In some cases this will report a poorly connected power cable.
4. Rerun the diagnostics, using the same GPU, on system that is known to be working. A variety of system issues can cause diagnostic failure.
5. If the problem remains, contact your IBM technical-support representative.

**Related links**

- [IBM Support website](#)
- [Latest level of DSA](#)
- [Latest level of BMC/IMM](#)

- **409-905-000 : Nvidia::DiagnosticServiceProvider::Matrix Test Failed**

Nvidia GPU Matrix Test Failed.

**Recoverable**

No

**Severity**

Error

**Serviceable**

Yes

**Automatically notify support**

No



### User Response

Complete the following steps:

1. Verify that the GPU is seated in the PCIe slot correctly by reseating the GPU. Then power cycle the system.
2. Verify that the power connectors to the GPU are connected firmly. Then power cycle the system.
3. Run `nvidia-smi -q` In some cases this will report a poorly connected power cable.
4. Rerun the diagnostics, using the same GPU, on system that is known to be working. A variety of system issues can cause diagnostic failure.
5. If the problem remains, contact your IBM technical-support representative.

### Related links

- [IBM Support website](#)
  - [Latest level of DSA](#)
  - [Latest level of BMC/IMM](#)
- **409-906-000 : Nvidia::DiagnosticServiceProvider::Binomial Test Failed**

Nvidia GPU Binomial Test Failed.

### Recoverable

No

### Severity

Error

### Serviceable

Yes

### Automatically notify support

No

### User Response

Complete the following steps:

1. Verify that the GPU is seated in the PCIe slot correctly by reseating the GPU. Then power cycle the system.
2. Verify that the power connectors to the GPU are connected firmly. Then power cycle the system.
3. Run `nvidia-smi -q` In some cases this will report a poorly connected power cable.
4. Rerun the diagnostics, using the same GPU, on system that is known to be working. A variety of system issues can cause diagnostic failure.
5. If the problem remains, contact your IBM technical-support representative.

### Related links

- [IBM Support website](#)
- [Latest level of DSA](#)
- [Latest level of BMC/IMM](#)

## DSA system management test results

The following messages can result when you run the system management test.

### Test results for the DSA system management test

The following messages can result when you run the DSA system management test.

- **166-000-001 : IMM I2C Test Passed**

IMM I2C Test Passed.

**Recoverable**

No

**Severity**

Event

**Serviceable**

No

**Automatically notify support**

No

**Related links**

- [IBM Support website](#)
- [Latest level of DSA](#)
- [Latest level of BMC/IMM](#)

- **166-801-001 : IMM I2C Test Aborted**

IMM returned incorrect response length.

**Recoverable**

No

**Severity**

Warning

**Serviceable**

Yes

**Automatically notify support**

No

**User Response**

Perform the actions mentioned one at a time and try the test after each action:

1. Turn off the system and disconnect it from power. Wait for 45 seconds. Reconnect it to power.
2. Make sure that DSA and BMC/IMM are at the latest level.

**Related links**

- [IBM Support website](#)
- [Latest level of DSA](#)
- [Latest level of BMC/IMM](#)

- **166-802-001 : IMM I2C Test Aborted**

Test cannot be completed for unknown reason.

**Recoverable**

No

**Severity**

Warning

**Serviceable**

Yes

**Automatically notify support**

No

**User Response**

Perform the actions mentioned one at a time and try the test after each action:

1. Turn off the system and disconnect it from power. Wait for 45 seconds. Reconnect it to power.
2. Make sure that DSA and BMC/IMM are at the latest level.

**Related links**

- [IBM Support website](#)
- [Latest level of DSA](#)
- [Latest level of BMC/IMM](#)

- **166-803-001 : IMM I2C Test Aborted**

Node Busy. Try later.

**Recoverable**

No

**Severity**

Warning

**Serviceable**

Yes

**Automatically notify support**

No

**User Response**

Perform the actions mentioned one at a time and try the test after each action:

1. Turn off the system and disconnect it from power. Wait for 45 seconds. Reconnect it to power.
2. Make sure that DSA and BMC/IMM are at the latest level.

**Related links**

- [IBM Support website](#)
- [Latest level of DSA](#)
- [Latest level of BMC/IMM](#)

- **166-804-001 : IMM I2C Test Aborted**

Invalid Command.

**Recoverable**

No

**Severity**

Warning

**Serviceable**

Yes

**Automatically notify support**

No

**User Response**

Perform the actions mentioned one at a time and try the test after each action:

1. Turn off the system and disconnect it from power. Wait for 45 seconds. Reconnect it to power.
2. Make sure that DSA and BMC/IMM are at the latest level.

**Related links**

- [IBM Support website](#)
- [Latest level of DSA](#)
- [Latest level of BMC/IMM](#)

- **166-805-001 : IMM I2C Test Aborted**

Invalid Command for given LUN.

**Recoverable**

No

**Severity**

Warning

**Serviceable**

Yes

**Automatically notify support**

No

**User Response**

Perform the actions mentioned one at a time and try the test after each action:

1. Turn off the system and disconnect it from power. Wait for 45 seconds. Reconnect it to power.
2. Make sure that DSA and BMC/IMM are at the latest level.

**Related links**

- [IBM Support website](#)
- [Latest level of DSA](#)
- [Latest level of BMC/IMM](#)

- **166-806-001 : IMM I2C Test Aborted**

Timeout while processing command.

**Recoverable**

No

**Severity**

Warning

**Serviceable**

Yes

**Automatically notify support**

No

**User Response**

Perform the actions mentioned one at a time and try the test after each action:

1. Turn off the system and disconnect it from power. Wait for 45 seconds. Reconnect it to power.
2. Make sure that DSA and BMC/IMM are at the latest level.

**Related links**

- [IBM Support website](#)
- [Latest level of DSA](#)
- [Latest level of BMC/IMM](#)

- **166-807-001 : IMM I2C Test Aborted**

Out of space.

**Recoverable**

No

**Severity**

Warning

**Serviceable**

Yes

**Automatically notify support**

No

**User Response**

Perform the actions mentioned one at a time and try the test after each action:

1. Turn off the system and disconnect it from power. Wait for 45 seconds. Reconnect it to power.
2. Make sure that DSA and BMC/IMM are at the latest level.

**Related links**

- [IBM Support website](#)
- [Latest level of DSA](#)
- [Latest level of BMC/IMM](#)

- **166-808-001 : IMM I2C Test Aborted**

Reservation Canceled or Invalid Reservation ID.

**Recoverable**

No

**Severity**

Warning

**Serviceable**

Yes

**Automatically notify support**

No

**User Response**

Perform the actions mentioned one at a time and try the test after each action:

1. Turn off the system and disconnect it from power. Wait for 45 seconds. Reconnect it to power.
2. Make sure that DSA and BMC/IMM are at the latest level.

**Related links**

- [IBM Support website](#)
- [Latest level of DSA](#)
- [Latest level of BMC/IMM](#)

- **166-809-001 : IMM I2C Test Aborted**

Request data truncated.

**Recoverable**

No

**Severity**

Warning

**Serviceable**

Yes

**Automatically notify support**

No

**User Response**

Perform the actions mentioned one at a time and try the test after each action:

1. Turn off the system and disconnect it from power. Wait for 45 seconds. Reconnect it to power.
2. Make sure that DSA and BMC/IMM are at the latest level.

**Related links**

- [IBM Support website](#)
- [Latest level of DSA](#)
- [Latest level of BMC/IMM](#)

- **166-810-001 : IMM I2C Test Aborted**

Request data length invalid.

**Recoverable**

No

**Severity**

Warning

**Serviceable**

Yes

**Automatically notify support**

No

**User Response**

Perform the actions mentioned one at a time and try the test after each action:

1. Turn off the system and disconnect it from power. Wait for 45 seconds. Reconnect it to power.
2. Make sure that DSA and BMC/IMM are at the latest level.

**Related links**

- [IBM Support website](#)
- [Latest level of DSA](#)
- [Latest level of BMC/IMM](#)

- **166-811-001 : IMM I2C Test Aborted**

Request data field length limit exceeded.

**Recoverable**

No

**Severity**

Warning

**Serviceable**

Yes

**Automatically notify support**

No

**User Response**

Perform the actions mentioned one at a time and try the test after each action:

1. Turn off the system and disconnect it from power. Wait for 45 seconds. Reconnect it to power.
2. Make sure that DSA and BMC/IMM are at the latest level.

**Related links**

- [IBM Support website](#)
- [Latest level of DSA](#)
- [Latest level of BMC/IMM](#)

- **166-812-001 : IMM I2C Test Aborted**

Parameter out of range.

**Recoverable**

No

**Severity**

Warning

**Serviceable**

Yes

**Automatically notify support**

No

**User Response**

Perform the actions mentioned one at a time and try the test after each action:

1. Turn off the system and disconnect it from power. Wait for 45 seconds. Reconnect it to power.
2. Make sure that DSA and BMC/IMM are at the latest level.

**Related links**

- [IBM Support website](#)
- [Latest level of DSA](#)
- [Latest level of BMC/IMM](#)

- **166-813-001 : IMM I2C Test Aborted**

Cannot return number of requested data bytes.

**Recoverable**

No

**Severity**

Warning

**Serviceable**

Yes

**Automatically notify support**

No

**User Response**

Perform the actions mentioned one at a time and try the test after each action:

1. Turn off the system and disconnect it from power. Wait for 45 seconds. Reconnect it to power.
2. Make sure that DSA and BMC/IMM are at the latest level.

**Related links**

- [IBM Support website](#)
- [Latest level of DSA](#)
- [Latest level of BMC/IMM](#)

- **166-814-001 : IMM I2C Test Aborted**

Requested Sensor, data, or record not present.

**Recoverable**

No

**Severity**

Warning

**Serviceable**

Yes

**Automatically notify support**

No

**User Response**

Perform the actions mentioned one at a time and try the test after each action:

1. Turn off the system and disconnect it from power. Wait for 45 seconds. Reconnect it to power.
2. Make sure that DSA and BMC/IMM are at the latest level.

**Related links**

- [IBM Support website](#)
- [Latest level of DSA](#)
- [Latest level of BMC/IMM](#)

- **166-815-001 : IMM I2C Test Aborted**

Invalid data field in Request.

**Recoverable**

No

**Severity**

Warning

**Serviceable**

Yes

**Automatically notify support**

No

**User Response**

Perform the actions mentioned one at a time and try the test after each action:

1. Turn off the system and disconnect it from power. Wait for 45 seconds. Reconnect it to power.
2. Make sure that DSA and BMC/IMM are at the latest level.

**Related links**

- [IBM Support website](#)
- [Latest level of DSA](#)
- [Latest level of BMC/IMM](#)

• **166-816-001 : IMM I2C Test Aborted**

Command illegal for specified sensor or record type.

**Recoverable**

No

**Severity**

Warning

**Serviceable**

Yes

**Automatically notify support**

No

**User Response**

Perform the actions mentioned one at a time and try the test after each action:

1. Turn off the system and disconnect it from power. Wait for 45 seconds. Reconnect it to power.
2. Make sure that DSA and BMC/IMM are at the latest level.

**Related links**

- [IBM Support website](#)
- [Latest level of DSA](#)
- [Latest level of BMC/IMM](#)

• **166-817-001 : IMM I2C Test Aborted**

Command response could not be provided.

**Recoverable**

No

**Severity**

Warning

**Serviceable**

Yes



**Automatically notify support**

No

**User Response**

Perform the actions mentioned one at a time and try the test after each action:

1. Turn off the system and disconnect it from power. Wait for 45 seconds. Reconnect it to power.
2. Make sure that DSA and BMC/IMM are at the latest level.

**Related links**

- [IBM Support website](#)
- [Latest level of DSA](#)
- [Latest level of BMC/IMM](#)

- **166-818-001 : IMM I2C Test Aborted**

Cannot execute duplicated request.

**Recoverable**

No

**Severity**

Warning

**Serviceable**

Yes

**Automatically notify support**

No

**User Response**

Perform the actions mentioned one at a time and try the test after each action:

1. Turn off the system and disconnect it from power. Wait for 45 seconds. Reconnect it to power.
2. Make sure that DSA and BMC/IMM are at the latest level.

**Related links**

- [IBM Support website](#)
- [Latest level of DSA](#)
- [Latest level of BMC/IMM](#)

- **166-819-001 : IMM I2C Test Aborted**

Command response could not be provided. SDR Repository in?update mode.

**Recoverable**

No

**Severity**

Warning

**Serviceable**

Yes

**Automatically notify support**

No

**User Response**

Perform the actions mentioned one at a time and try the test after each action:

1. Turn off the system and disconnect it from power. Wait for 45 seconds. Reconnect it to power.
2. Make sure that DSA and BMC/IMM are at the latest level.

**Related links**

- [IBM Support website](#)

- [Latest level of DSA](#)
- [Latest level of BMC/IMM](#)

- **166-820-001 : IMM I2C Test Aborted**

Command response could not be provided. Device in firmware update mode.

**Recoverable**

No

**Severity**

Warning

**Serviceable**

Yes

**Automatically notify support**

No

**User Response**

Perform the actions mentioned one at a time and try the test after each action:

1. Turn off the system and disconnect it from power. Wait for 45 seconds. Reconnect it to power.
2. Make sure that DSA and BMC/IMM are at the latest level.

**Related links**

- [IBM Support website](#)
- [Latest level of DSA](#)
- [Latest level of BMC/IMM](#)

- **166-821-001 : IMM I2C Test Aborted**

Command response could not be provided. BMC initialization in progress.

**Recoverable**

No

**Severity**

Warning

**Serviceable**

Yes

**Automatically notify support**

No

**User Response**

Perform the actions mentioned one at a time and try the test after each action:

1. Turn off the system and disconnect it from power. Wait for 45 seconds. Reconnect it to power.
2. Make sure that DSA and BMC/IMM are at the latest level.

**Related links**

- [IBM Support website](#)
- [Latest level of DSA](#)
- [Latest level of BMC/IMM](#)

- **166-822-001 : IMM I2C Test Aborted**

Destination unavailable.

**Recoverable**

No

**Severity**

Warning

**Serviceable**

Yes

**Automatically notify support**

No

**User Response**

Perform the actions mentioned one at a time and try the test after each action:

1. Turn off the system and disconnect it from power. Wait for 45 seconds. Reconnect it to power.
2. Make sure that DSA and BMC/IMM are at the latest level.

**Related links**

- [IBM Support website](#)
- [Latest level of DSA](#)
- [Latest level of BMC/IMM](#)

- **166-823-001 : IMM I2C Test Aborted**

Cannot execute command. Insufficient privilege level.

**Recoverable**

No

**Severity**

Warning

**Serviceable**

Yes

**Automatically notify support**

No

**User Response**

Perform the actions mentioned one at a time and try the test after each action:

1. Turn off the system and disconnect it from power. Wait for 45 seconds. Reconnect it to power.
2. Make sure that DSA and BMC/IMM are at the latest level.

**Related links**

- [IBM Support website](#)
- [Latest level of DSA](#)
- [Latest level of BMC/IMM](#)

- **166-824-001 : IMM I2C Test Aborted**

Cannot execute command.

**Recoverable**

No

**Severity**

Warning

**Serviceable**

Yes

**Automatically notify support**

No

**User Response**

Perform the actions mentioned one at a time and try the test after each action:

1. Turn off the system and disconnect it from power. Wait for 45 seconds. Reconnect it to power.
2. Make sure that DSA and BMC/IMM are at the latest level.

**Related links**

- [IBM Support website](#)
- [Latest level of DSA](#)
- [Latest level of BMC/IMM](#)

- **166-901-001 : IMM I2C Test Failed**

IMM Indicates failure in RTMM bus (BUS 0).

**Recoverable**

No

**Severity**

Error

**Serviceable**

Yes

**Automatically notify support**

No

**User Response**

Perform the actions mentioned one at a time and try the test after each action:

1. Turn off the system and disconnect it from power. Wait for 45 seconds. Reconnect it to power.
2. Make sure that DSA and BMC/IMM are at the latest level.
3. Run the test again.
4. If failure remains, refer to "Troubleshooting by symptom" in the system "Installation and Service Guide" for the next corrective action.

**Related links**

- [IBM Support website](#)
- [Latest level of DSA](#)
- [Latest level of BMC/IMM](#)

- **166-902-001 : IMM I2C Test Failed**

IMM Indicates failure in TPM bus (BUS 1).

**Recoverable**

No

**Severity**

Error

**Serviceable**

Yes

**Automatically notify support**

No

**User Response**

Perform the actions mentioned one at a time and try the test after each action:

1. Turn off the system and disconnect it from power. Wait for 45 seconds. Reconnect it to power.
2. Make sure that DSA and BMC/IMM are at the latest level.
3. Run the test again.
4. If failure remains, refer to "Troubleshooting by symptom" in the system "Installation and Service Guide" for the next corrective action.

**Related links**

- [IBM Support website](#)

- [Latest level of DSA](#)
- [Latest level of BMC/IMM](#)

- **166-904-001 : IMM I2C Test Failed**

IMM Indicates failure in DS2482 bus (BUS 3).

**Recoverable**

No

**Severity**

Error

**Serviceable**

Yes

**Automatically notify support**

No

**User Response**

Perform the actions mentioned one at a time and try the test after each action:

1. Turn off the system and disconnect it from power. Wait for 45 seconds. Reconnect it to power.
2. Make sure that DSA and BMC/IMM are at the latest level.
3. Run the test again.
4. If failure remains, refer to "Troubleshooting by symptom" in the system "Installation and Service Guide" for the next corrective action.

**Related links**

- [IBM Support website](#)
- [Latest level of DSA](#)
- [Latest level of BMC/IMM](#)

- **166-905-001 : IMM I2C Test Failed**

IMM Indicates failure in SAS Backplane bus (BUS 4).

**Recoverable**

No

**Severity**

Error

**Serviceable**

Yes

**Automatically notify support**

No

**User Response**

Perform the actions mentioned one at a time and try the test after each action:

1. Turn off the system and disconnect it from power. Wait for 45 seconds. Reconnect it to power.
2. Make sure that DSA and BMC/IMM are at the latest level.
3. Run the test again.
4. If failure remains, refer to "Troubleshooting by symptom" in the system "Installation and Service Guide" for the next corrective action.

**Related links**

- [IBM Support website](#)
- [Latest level of DSA](#)
- [Latest level of BMC/IMM](#)

- **166-906-001 : IMM I2C Test Failed**

IMM Indicates failure in Patsburg bus (BUS 5).

**Recoverable**

No

**Severity**

Error

**Serviceable**

Yes

**Automatically notify support**

No

**User Response**

Perform the actions mentioned one at a time and try the test after each action:

1. Turn off the system and disconnect it from power. Wait for 45 seconds. Reconnect it to power.
2. Make sure that DSA and BMC/IMM are at the latest level.
3. Run the test again.
4. If failure remains, refer to "Troubleshooting by symptom" in the system "Installation and Service Guide" for the next corrective action.

**Related links**

- [IBM Support website](#)
- [Latest level of DSA](#)
- [Latest level of BMC/IMM](#)

- **166-907-001 : IMM I2C Test Failed**

IMM Indicates failure in the I2C Mux bus (BUS 6).

**Recoverable**

No

**Severity**

Error

**Serviceable**

Yes

**Automatically notify support**

No

**User Response**

Perform the actions mentioned one at a time and try the test after each action:

1. Turn off the system and disconnect it from power. Wait for 45 seconds. Reconnect it to power.
2. Make sure that DSA and BMC/IMM are at the latest level.
3. Run the test again.
4. If failure remains, refer to "Troubleshooting by symptom" in the system "Installation and Service Guide" for the next corrective action.

**Related links**

- [IBM Support website](#)
- [Latest level of DSA](#)
- [Latest level of BMC/IMM](#)

## DSA checkpoint panel test results

The following messages can result when you run the checkpoint panel test.

### Test results for the DSA checkpoint panel test

The following messages can result when you run the DSA checkpoint panel test.

- **180-000-000 : Check-point Panel Test Passed**

Check-point Panel Test Passed.

**Recoverable**

No

**Severity**

Event

**Serviceable**

No

**Automatically notify support**

No

**Related links**

- [IBM Support website](#)
- [Latest level of DSA](#)
- [Latest level of BMC/IMM](#)

- **180-801-000 : Check-point Panel Test Aborted**

Check-point Panel Test Aborted. BMC is unable to verify that the operator information panel cable is connected.

**Recoverable**

No

**Severity**

Warning

**Serviceable**

Yes

**Automatically notify support**

No

**User Response**

Complete the following steps:

1. Inspect and reseal operator information panel cable at both ends.
2. Verify that the Baseboard Management Controller (BMC) is working.
3. Run the test again.
4. If failure remains, refer to "Troubleshooting by symptom" in the system "Installation and Service Guide" for the next corrective action.

**Related links**

- [IBM Support website](#)
- [Latest level of DSA](#)
- [Latest level of BMC/IMM](#)

- **180-901-000 : Check-point Panel Test Failed**

Check-point Panel Test Failed. Operator reported incorrect display.

**Recoverable**

No

**Severity**

Error

**Serviceable**

Yes

**Automatically notify support**

No

**User Response**

Complete the following steps:

1. Check the operator information panel cabling for loose or broken connections at both ends or damage to the cable.
2. Replace the information panel cable if damage is present.
3. Run the test again.
4. Replace the operator information panel assembly.
5. Run the test again.
6. If failure remains, refer to "Troubleshooting by symptom" in the system "Installation and Service Guide" for the next corrective action.

**Related links**

- [IBM Support website](#)
- [Latest level of DSA](#)
- [Latest level of BMC/IMM](#)

## DSA Broadcom network test results

The following messages can result when you run the Broadcom network test.

### Test results for the DSA Broadcom network test

The following messages can result when you run the DSA Broadcom network test.

- **405-000-000 : BRCM:TestControlRegisters Test Passed**

The test passed.

**Recoverable**

No

**Severity**

Event

**Serviceable**

No

**Automatically notify support**

No

**Related links**

- [IBM Support website](#)
- [Latest level of DSA](#)
- [Latest level of BMC/IMM](#)

- **405-001-000 : BRCM:TestMIRegisters Test Passed**

The test passed.

**Recoverable**



No

**Severity**

Event

**Serviceable**

No

**Automatically notify support**

No

**Related links**

- [IBM Support website](#)
- [Latest level of DSA](#)
- [Latest level of BMC/IMM](#)

• **405-002-000 : BRCM:TestEEPROM Test Passed**

The test passed.

**Recoverable**

No

**Severity**

Event

**Serviceable**

No

**Automatically notify support**

No

**Related links**

- [IBM Support website](#)
- [Latest level of DSA](#)
- [Latest level of BMC/IMM](#)

• **405-003-000 : BRCM:TestInternalMemory Test Passed**

The test passed.

**Recoverable**

No

**Severity**

Event

**Serviceable**

No

**Automatically notify support**

No

**Related links**

- [IBM Support website](#)
- [Latest level of DSA](#)
- [Latest level of BMC/IMM](#)

• **405-004-000 : BRCM:TestInterrupt Test Passed**

The test passed.

**Recoverable**

No

**Severity**

Event

**Serviceable**

No

**Automatically notify support**

No

**Related links**

- [IBM Support website](#)
- [Latest level of DSA](#)
- [Latest level of BMC/IMM](#)

• **405-005-000 : BRCM:TestLoopbackMAC Test Passed**

The test passed.

**Recoverable**

No

**Severity**

Event

**Serviceable**

No

**Automatically notify support**

No

**Related links**

- [IBM Support website](#)
- [Latest level of DSA](#)
- [Latest level of BMC/IMM](#)

• **405-006-000 : BRCM:TestLoopbackPhysical Test Passed**

The test passed.

**Recoverable**

No

**Severity**

Event

**Serviceable**

No

**Automatically notify support**

No

**Related links**

- [IBM Support website](#)
- [Latest level of DSA](#)
- [Latest level of BMC/IMM](#)

• **405-007-000 : BRCM:TestLEDs Test Passed**

The test passed.

**Recoverable**

No

**Severity**

Event

**Serviceable**

No

**Automatically notify support**

No

**Related links**

- [IBM Support website](#)
- [Latest level of DSA](#)
- [Latest level of BMC/IMM](#)

• **405-800-000 : BRCM:TestControlRegisters Test Aborted**

The control registers test was canceled.

**Recoverable**

No

**Severity**

Warning

**Serviceable**

No

**Automatically notify support**

No

**Related links**

- [IBM Support website](#)
- [Latest level of DSA](#)
- [Latest level of BMC/IMM](#)

• **405-801-000 : BRCM:TestMIIRegisters Test Aborted**

The MII register test was canceled.

**Recoverable**

No

**Severity**

Warning

**Serviceable**

No

**Automatically notify support**

No

**Related links**

- [IBM Support website](#)
- [Latest level of DSA](#)
- [Latest level of BMC/IMM](#)

• **405-802-000 : BRCM:TestEEPROM Test Aborted**

The EEPROM test was canceled.

**Recoverable**

No

**Severity**

Warning

**Serviceable**

No

**Automatically notify support**

No

**Related links**

- [IBM Support website](#)
- [Latest level of DSA](#)
- [Latest level of BMC/IMM](#)

• **405-803-000 : BRCM:TestInternalMemory Test Aborted**

The internal memory test was canceled.

**Recoverable**

No

**Severity**

Warning

**Serviceable**

No

**Automatically notify support**

No

**Related links**

- [IBM Support website](#)
- [Latest level of DSA](#)
- [Latest level of BMC/IMM](#)

• **405-804-000 : BRCM:TestInterrupt Test Aborted**

The interrupt test was canceled.

**Recoverable**

No

**Severity**

Warning

**Serviceable**

No

**Automatically notify support**

No

**Related links**

- [IBM Support website](#)
- [Latest level of DSA](#)
- [Latest level of BMC/IMM](#)

• **405-805-000 : BRCM:TestLoopbackMAC Test Aborted**

Loopback testing at the MAC layer was canceled.

**Recoverable**

No

**Severity**

Warning

**Serviceable**

No

**Automatically notify support**

No

**Related links**

- [IBM Support website](#)
- [Latest level of DSA](#)
- [Latest level of BMC/IMM](#)

- **405-806-000 : BRCM:TestLoopbackPhysical Test Aborted**

Loopback testing at the physical layer was canceled.

**Recoverable**

No

**Severity**

Warning

**Serviceable**

No

**Automatically notify support**

No

**Related links**

- [IBM Support website](#)
- [Latest level of DSA](#)
- [Latest level of BMC/IMM](#)

- **405-807-000 : BRCM:TestLEDs Test Aborted**

Verification of status LEDs was canceled.

**Recoverable**

No

**Severity**

Warning

**Serviceable**

No

**Automatically notify support**

No

**Related links**

- [IBM Support website](#)
- [Latest level of DSA](#)
- [Latest level of BMC/IMM](#)

- **405-900-000 : BRCM:TestControlRegisters Test Failed**

A failure was detected while testing internal MAC registers

**Recoverable**

No

**Severity**

Error

**Serviceable**

Yes

**Automatically notify support**

No

**User Response**

Complete the following steps:

1. Check component firmware level and upgrade if necessary. The installed firmware level can be found in the DSA Diagnostic Event Log within the Firmware/VPD section for this component.
2. Rerun the test.
3. If failure remains, refer to "Troubleshooting by symptom" in the system "Installation and Service Guide" for the next corrective action.

**Related links**

- [IBM Support website](#)
- [Latest level of DSA](#)
- [Latest level of BMC/IMM](#)

- **405-901-000 : BRCM:TestMIRegisters Test Failed**

A failure was detected while testing internal PHY registers.

**Recoverable**

No

**Severity**

Error

**Serviceable**

Yes

**Automatically notify support**

No

**User Response**

Complete the following steps:

1. Check component firmware level and upgrade if necessary. The installed firmware level can be found in the DSA Diagnostic Event Log within the Firmware/VPD section for this component.
2. Rerun the test.
3. If failure remains, refer to "Troubleshooting by symptom" in the system "Installation and Service Guide" for the next corrective action.

**Related links**

- [IBM Support website](#)
- [Latest level of DSA](#)
- [Latest level of BMC/IMM](#)

- **405-902-000 : BRCM:TestEEPROM Test Failed**

A failure was detected while testing non-volatile RAM.

**Recoverable**

No

**Severity**

Error

**Serviceable**

Yes

**Automatically notify support**

No

**User Response**

Complete the following steps:

1. Check component firmware level and upgrade if necessary. The installed firmware level can be found in the DSA Diagnostic Event Log within the Firmware/VPD section for this component.
2. Rerun the test.

3. If failure remains, refer to "Troubleshooting by symptom" in the system "Installation and Service Guide" for the next corrective action.

**Related links**

- [IBM Support website](#)
- [Latest level of DSA](#)
- [Latest level of BMC/IMM](#)

- **405-903-000 : BRCM:TestInternalMemory Test Failed**

A failure was detected while testing internal memory.

**Recoverable**

No

**Severity**

Error

**Serviceable**

Yes

**Automatically notify support**

No

**User Response**

Complete the following steps:

1. Check component firmware level and upgrade if necessary. The installed firmware level can be found in the DSA Diagnostic Event Log within the Firmware/VPD section for this component.
2. Rerun the test.
3. If failure remains, refer to "Troubleshooting by symptom" in the system "Installation and Service Guide" for the next corrective action.

**Related links**

- [IBM Support website](#)
- [Latest level of DSA](#)
- [Latest level of BMC/IMM](#)

- **405-904-000 : BRCM:TestInterrupt Test Failed**

A failure was detected while testing interrupts.

**Recoverable**

No

**Severity**

Error

**Serviceable**

Yes

**Automatically notify support**

No

**User Response**

Complete the following steps:

1. Check component firmware level and upgrade if necessary. The installed firmware level can be found in the DSA Diagnostic Event Log within the Firmware/VPD section for this component.
2. Rerun the test.
3. If failure remains, refer to "Troubleshooting by symptom" in the system "Installation and Service Guide" for the next corrective action.

**Related links**

- [IBM Support website](#)
- [Latest level of DSA](#)
- [Latest level of BMC/IMM](#)

- **405-905-000 : BRCM:TestLoopbackMAC Test Failed**

BRCM:TestLoopbackMAC Test Failed.

**Recoverable**

No

**Severity**

Error

**Serviceable**

Yes

**Automatically notify support**

No

**User Response**

Complete the following steps:

1. Check component firmware level and upgrade if necessary. The installed firmware level can be found in the DSA Diagnostic Event Log within the Firmware/VPD section for this component.
2. Rerun the test.
3. If failure remains, refer to "Troubleshooting by symptom" in the system "Installation and Service Guide" for the next corrective action.

**Related links**

- [IBM Support website](#)
- [Latest level of DSA](#)
- [Latest level of BMC/IMM](#)

- **405-906-000 : BRCM:TestLoopbackPhysical Test Failed**

A failure was detected during the loopback test at the physical layer.

**Recoverable**

No

**Severity**

Error

**Serviceable**

Yes

**Automatically notify support**

No

**User Response**

Complete the following steps:

1. Check component firmware level and upgrade if necessary. The installed firmware level can be found in the DSA Diagnostic Event Log within the Firmware/VPD section for this component.
2. Rerun the test.
3. If failure remains, refer to "Troubleshooting by symptom" in the system "Installation and Service Guide" for the next corrective action.

**Related links**

- [IBM Support website](#)
- [Latest level of DSA](#)
- [Latest level of BMC/IMM](#)



- **405-907-000 : BRCM:TestLEDs Test Failed**

A failure was detected while verifying operation of the status LEDs.

**Recoverable**

No

**Severity**

Error

**Serviceable**

Yes

**Automatically notify support**

No

**User Response**

Complete the following steps:

1. Check component firmware level and upgrade if necessary. The installed firmware level can be found in the DSA Diagnostic Event Log within the Firmware/VPD section for this component.
2. Rerun the test.
3. If failure remains, refer to "Troubleshooting by symptom" in the system "Installation and Service Guide" for the next corrective action.

**Related links**

- [IBM Support website](#)
- [Latest level of DSA](#)
- [Latest level of BMC/IMM](#)

## **DSA Brocade test results**

The following messages can result when you run the Brocade test.

### **Test results for the DSA Brocade test**

The following messages can result when you run the DSA Brocade test.

- **218-000-000 : Brocade:MemoryTest Passed**

The test passed.

**Recoverable**

No

**Severity**

Event

**Serviceable**

No

**Automatically notify support**

No

**Related links**

- [IBM Support website](#)
- [Latest level of DSA](#)
- [Latest level of BMC/IMM](#)

- **218-001-000 : Brocade:ExternalLoopbackTest Passed**

The test passed.

**Recoverable**

No

**Severity**

Event

**Serviceable**

No

**Automatically notify support**

No

**Related links**

- [IBM Support website](#)
- [Latest level of DSA](#)
- [Latest level of BMC/IMM](#)

• **218-002-000 : Brocade:SerdesLoopbackTest Passed**

The test passed.

**Recoverable**

No

**Severity**

Event

**Serviceable**

No

**Automatically notify support**

No

**Related links**

- [IBM Support website](#)
- [Latest level of DSA](#)
- [Latest level of BMC/IMM](#)

• **218-003-000 : Brocade:PCILoopbackTest Passed**

The test passed.

**Recoverable**

No

**Severity**

Event

**Serviceable**

No

**Automatically notify support**

No

**Related links**

- [IBM Support website](#)
- [Latest level of DSA](#)
- [Latest level of BMC/IMM](#)

• **218-004-000 : Brocade:ExternalEthLoopbackTest Passed**

The test passed.

**Recoverable**

No

**Severity**

Event

**Serviceable**

No

**Automatically notify support**

No

**Related links**

- [IBM Support website](#)
- [Latest level of DSA](#)
- [Latest level of BMC/IMM](#)

• **218-005-000 : Brocade:SerdesEthLoopbackTest Passed**

The test passed.

**Recoverable**

No

**Severity**

Event

**Serviceable**

No

**Automatically notify support**

No

**Related links**

- [IBM Support website](#)
- [Latest level of DSA](#)
- [Latest level of BMC/IMM](#)

• **218-006-000 : Brocade:InternalLoopbackTest Passed**

The test passed.

**Recoverable**

No

**Severity**

Event

**Serviceable**

No

**Automatically notify support**

No

**Related links**

- [IBM Support website](#)
- [Latest level of DSA](#)
- [Latest level of BMC/IMM](#)

• **218-800-000 : Brocade:MemoryTest Aborted**

The test was canceled.

**Recoverable**

No

**Severity**

Warning

**Serviceable**

No

**Automatically notify support**

No

**Related links**

- [IBM Support website](#)
- [Latest level of DSA](#)
- [Latest level of BMC/IMM](#)

• **218-801-000 : Brocade:ExternalLoopbackTest Aborted**

The test was canceled.

**Recoverable**

No

**Severity**

Warning

**Serviceable**

No

**Automatically notify support**

No

**Related links**

- [IBM Support website](#)
- [Latest level of DSA](#)
- [Latest level of BMC/IMM](#)

• **218-802-000 : Brocade:SerdesLoopbackTest Aborted**

The test was canceled.

**Recoverable**

No

**Severity**

Warning

**Serviceable**

No

**Automatically notify support**

No

**Related links**

- [IBM Support website](#)
- [Latest level of DSA](#)
- [Latest level of BMC/IMM](#)

• **218-803-000 : Brocade:PCILoopbackTest Aborted**

The test was canceled.

**Recoverable**

No

**Severity**

Warning

**Serviceable**

No

**Automatically notify support**

No

**Related links**

- [IBM Support website](#)
- [Latest level of DSA](#)
- [Latest level of BMC/IMM](#)

• **218-804-000 : Brocade:ExternalEthLoopbackTest Aborted**

The test was canceled.

**Recoverable**

No

**Severity**

Warning

**Serviceable**

No

**Automatically notify support**

No

**Related links**

- [IBM Support website](#)
- [Latest level of DSA](#)
- [Latest level of BMC/IMM](#)

• **218-805-000 : Brocade:SerdesEthLoopbackTest Aborted**

The test was canceled.

**Recoverable**

No

**Severity**

Warning

**Serviceable**

No

**Automatically notify support**

No

**Related links**

- [IBM Support website](#)
- [Latest level of DSA](#)
- [Latest level of BMC/IMM](#)

• **218-806-000 : Brocade:InternalLoopbackTest Aborted**

The test was canceled.

**Recoverable**

No

**Severity**

Warning

**Serviceable**

No

**Automatically notify support**

No

**Related links**

- [IBM Support website](#)
- [Latest level of DSA](#)
- [Latest level of BMC/IMM](#)

- **218-900-000 : Brocade:MemoryTest Failed**

A failure was detected while testing the adapter memory.

**Recoverable**

No

**Severity**

Error

**Serviceable**

Yes

**Automatically notify support**

No

**User Response**

Complete the following steps:

1. Rerun the test.
2. Verify whether the firmware is at proper level.
3. Rerun the test.
4. If the problem remains, contact your IBM technical-support representative.

**Related links**

- [IBM Support website](#)
- [Latest level of DSA](#)
- [Latest level of BMC/IMM](#)

- **218-901-000 : Brocade:ExternalLoopbackTest Failed**

A failure was detected during the Loopback test.

**Recoverable**

No

**Severity**

Error

**Serviceable**

Yes

**Automatically notify support**

No

**User Response**

Complete the following steps:

1. Check cable connections.
2. Rerun the test.
3. Verify whether the firmware is at proper level.
4. Rerun the test.
5. If the problem remains, contact your IBM technical-support representative.

**Related links**

- [IBM Support website](#)
- [Latest level of DSA](#)
- [Latest level of BMC/IMM](#)

- **218-902-000 : Brocade:SerdesLoopbackTest Failed**

A failure was detected during the Loopback test.

**Recoverable**

No

**Severity**

Error

**Serviceable**

Yes

**Automatically notify support**

No

**User Response**

Complete the following steps:

1. Rerun the test.
2. Verify whether the firmware is at proper level.
3. Rerun the test.
4. If the problem remains, contact your IBM technical-support representative.

**Related links**

- [IBM Support website](#)
- [Latest level of DSA](#)
- [Latest level of BMC/IMM](#)

- **218-903-000 : Brocade:PCILoopbackTest Failed**

A failure was detected during the Loopback test.

**Recoverable**

No

**Severity**

Error

**Serviceable**

Yes

**Automatically notify support**

No

**User Response**

Complete the following steps:

1. Rerun the test.
2. Verify whether the firmware is at proper level.
3. Rerun the test.
4. If the problem remains, contact your IBM technical-support representative.

**Related links**

- [IBM Support website](#)
- [Latest level of DSA](#)
- [Latest level of BMC/IMM](#)

- **218-904-000 : Brocade:ExternalEthLoopbackTest Failed**

A failure was detected during the Loopback test.

**Recoverable**

No

**Severity**

Error

**Serviceable**

Yes

**Automatically notify support**

No

**User Response**

Complete the following steps:

1. Check or replace SFP/cable.
2. Rerun the test.
3. Verify whether the firmware is at proper level.
4. Rerun the test.
5. If the problem remains, contact your IBM technical-support representative.

**Related links**

- [IBM Support website](#)
- [Latest level of DSA](#)
- [Latest level of BMC/IMM](#)

• **218-905-000 : Brocade:SerdesEthLoopbackTest Failed**

A failure was detected during the Loopback test.

**Recoverable**

No

**Severity**

Error

**Serviceable**

Yes

**Automatically notify support**

No

**User Response**

Complete the following steps:

1. Rerun the test.
2. Verify whether the firmware is at proper level.
3. Rerun the test.
4. If the problem remains, contact your IBM technical-support representative.

**Related links**

- [IBM Support website](#)
- [Latest level of DSA](#)
- [Latest level of BMC/IMM](#)

• **218-906-000 : Brocade:InternalLoopbackTest Failed**

A failure was detected during the Loopback test.

**Recoverable**

No

**Severity**

Error



**Serviceable**

Yes

**Automatically notify support**

No

**User Response**

Complete the following steps:

1. Rerun the test.
2. Verify whether the firmware is at proper level.
3. Rerun the test.
4. If the problem remains, contact your IBM technical-support representative.

**Related links**

- [IBM Support website](#)
- [Latest level of DSA](#)
- [Latest level of BMC/IMM](#)

**DSA Emulex adapter test results**

The following messages can result when you run the Emulex adapter test.

**Test results for the DSA Emulex adapter test**

The following messages can result when you run the DSA Emulex adapter test.

- **516-000-000 : ELXUCNA: NIC MAC LoopBackTest Passed**

The test passed.

**Recoverable**

No

**Severity**

Event

**Serviceable**

No

**Automatically notify support**

No

**Related links**

- [IBM Support website](#)
- [Latest level of DSA](#)
- [Latest level of BMC/IMM](#)

- **516-001-000 : ELXUCNA: NIC PHY LoopBackTest Passed**

The test passed.

**Recoverable**

No

**Severity**

Event

**Serviceable**

No

**Automatically notify support**

No

**Related links**

- [IBM Support website](#)
- [Latest level of DSA](#)
- [Latest level of BMC/IMM](#)

- **516-002-000 : ELXUCNA: ELXUCNA: NIC LED(Beacon)Test Passed**

The test passed.

**Recoverable**

No

**Severity**

Event

**Serviceable**

No

**Automatically notify support**

No

**Related links**

- [IBM Support website](#)
- [Latest level of DSA](#)
- [Latest level of BMC/IMM](#)

- **516-800-000 : ELXUCNA: NIC MAC LoopBackTest Aborted**

Loopback testing at the MAC layer was canceled.

**Recoverable**

No

**Severity**

Warning

**Serviceable**

No

**Automatically notify support**

No

**Related links**

- [IBM Support website](#)
- [Latest level of DSA](#)
- [Latest level of BMC/IMM](#)

- **516-801-000 : ELXUCNA: NIC PHY LoopBackTest Aborted**

Loopback testing at the physical layer was canceled.

**Recoverable**

No

**Severity**

Warning

**Serviceable**

No

**Automatically notify support**

No

**Related links**

- [IBM Support website](#)
- [Latest level of DSA](#)

- [Latest level of BMC/IMM](#)
- **516-802-000 : ELXUCNA: ELXUCNA: NIC LED(Beacon)Test Aborted**

Verification of status LEDs was canceled.

**Recoverable**

No

**Severity**

Warning

**Serviceable**

No

**Automatically notify support**

No

**Related links**

- [IBM Support website](#)
- [Latest level of DSA](#)
- [Latest level of BMC/IMM](#)
- **516-900-000 : ELXUCNA: NIC MAC LoopBackTest Failed**

A failure was detected during the loopback test at the MAC layer.

**Recoverable**

No

**Severity**

Error

**Serviceable**

Yes

**Automatically notify support**

No

**User Response**

Complete the following steps:

1. Check component firmware level and upgrade if necessary. The installed firmware level can be found in the DSA Diagnostic Event Log within the Firmware/VPD section for this component.
2. Rerun the test.
3. If failure remains, refer to "Troubleshooting by symptom" in the system "Installation and Service Guide" for the next corrective action.

**Related links**

- [IBM Support website](#)
- [Latest level of DSA](#)
- [Latest level of BMC/IMM](#)
- **516-901-000 : ELXUCNA: NIC PHY LoopBackTest Failed**

A failure was detected during the loopback test at the physical layer.

**Recoverable**

No

**Severity**

Error

**Serviceable**

Yes

**Automatically notify support**

No

**User Response**

Complete the following steps:

1. Check component firmware level and upgrade if necessary. The installed firmware level can be found in the DSA Diagnostic Event Log within the Firmware/VPD section for this component.
2. Rerun the test.
3. If failure remains, refer to "Troubleshooting by symptom" in the system "Installation and Service Guide" for the next corrective action.

**Related links**

- [IBM Support website](#)
- [Latest level of DSA](#)
- [Latest level of BMC/IMM](#)

- **516-902-000 : ELXUCNA: ELXUCNA: NIC LED(Beacon)Test Failed**

A failure was detected while verifying operation of the status LEDs.

**Recoverable**

No

**Severity**

Error

**Serviceable**

Yes

**Automatically notify support**

No

**User Response**

Complete the following steps:

1. Check component firmware level and upgrade if necessary. The installed firmware level can be found in the DSA Diagnostic Event Log within the Firmware/VPD section for this component.
2. Rerun the test.
3. If failure remains, refer to "Troubleshooting by symptom" in the system "Installation and Service Guide" for the next corrective action.

**Related links**

- [IBM Support website](#)
- [Latest level of DSA](#)
- [Latest level of BMC/IMM](#)

**DSA Mellanox adapter test results**

The following messages can result when you run the Mellanox adapter test.

**Test results for the DSA Mellanox adapter test**

The following messages can result when you run the DSA Mellanox adapter test.

- **408-000-000 : MLNX:MLNX\_DiagnosticTestEthernetPort Test Passed**

Port Test Passed.

**Recoverable**

No

**Severity**

Event

**Serviceable**

No

**Automatically notify support**

No

**Related links**

- [IBM Support website](#)
- [Latest level of DSA](#)
- [Latest level of BMC/IMM](#)

- **408-001-000 : MLNX:MLNX\_DiagnosticTestIBPort Test Passed**

Port Test Passed.

**Recoverable**

No

**Severity**

Event

**Serviceable**

No

**Automatically notify support**

No

**Related links**

- [IBM Support website](#)
- [Latest level of DSA](#)
- [Latest level of BMC/IMM](#)

- **408-800-000 : MLNX:MLNX\_DiagnosticTestEthernetPort Test Aborted**

Port Test was canceled.

**Recoverable**

No

**Severity**

Warning

**Serviceable**

No

**Automatically notify support**

No

**Related links**

- [IBM Support website](#)
- [Latest level of DSA](#)
- [Latest level of BMC/IMM](#)

- **408-801-000 : MLNX:MLNX\_DiagnosticTestIBPort Test Aborted**

Port Test was canceled.

**Recoverable**

No

**Severity**

Warning

**Serviceable**

No

**Automatically notify support**

No

**Related links**

- [IBM Support website](#)
- [Latest level of DSA](#)
- [Latest level of BMC/IMM](#)

• **408-900-000 : MLNX:MLNX\_DiagnosticTestEthernetPort Test Failed**

Port Test Failed.

**Recoverable**

No

**Severity**

Error

**Serviceable**

Yes

**Automatically notify support**

No

**User Response**

Complete the following steps:

1. Make sure that the physical link of the port under test in the active state.
2. If these condition was met but the test keeps failing the port's adapter might be faulty.
3. Try replacing the adapter and repeating the test.

**Related links**

- [IBM Support website](#)
- [Latest level of DSA](#)
- [Latest level of BMC/IMM](#)

• **408-901-000 : MLNX:MLNX\_DiagnosticTestIBPort Test Failed**

Port Test Failed.

**Recoverable**

No

**Severity**

Error

**Serviceable**

Yes

**Automatically notify support**

No

**User Response**

Complete the following steps:

1. Make sure that the physical link of the port under test in the active state and a subnet manager running on the fabric to which the port is attached.
2. If these condition was met but the test keeps failing the port's adapter might be faulty.
3. Try replacing the adapter and repeating the test.

**Related links**

- [IBM Support website](#)

- [Latest level of DSA](#)
- [Latest level of BMC/IMM](#)

## DSA EXA port ping test results

The following messages can result when you run the EXA port ping test.

### Test results for the DSA EXA port ping test

The following messages can result when you run the DSA EXA port ping test.

- **401-000-000 : EXA Port Ping Test Passed**

EXA Port Ping Test Passed.

**Recoverable**

No

**Severity**

Event

**Serviceable**

No

**Automatically notify support**

No

**Related links**

- [IBM Support website](#)
- [Latest level of DSA](#)
- [Latest level of BMC/IMM](#)

- **401-801-000 : EXA Port Ping Test Aborted**

EXA Port Ping Test Aborted. Unable to get device base address.

**Recoverable**

No

**Severity**

Warning

**Serviceable**

Yes

**Automatically notify support**

No

**User Response**

Complete the following steps:

1. Remove power cables, wait for 45 seconds, reconnect and rerun the test.
2. Make sure that the scalability cable connections are as per specification.
3. Make sure that DSA and BIOS/uEFI are at the latest level.
4. If the problem remains, contact your technical-service representative.

**Related links**

- [IBM Support website](#)
- [Latest level of DSA](#)
- [Latest level of BMC/IMM](#)

- **401-802-000 : EXA Port Ping Test Aborted**

EXA Port Ping Test Aborted. Port connections may not be correct.

**Recoverable**

No

**Severity**

Warning

**Serviceable**

Yes

**Automatically notify support**

No

**User Response**

Complete the following steps:

1. Remove power cables, wait for 45 seconds, reconnect and rerun the test.
2. Make sure that the scalability cable connections are as per specification.
3. Make sure that DSA and BIOS/uEFI are at the latest level.
4. If the problem remains, contact your technical-service representative.

**Related links**

- [IBM Support website](#)
- [Latest level of DSA](#)
- [Latest level of BMC/IMM](#)

**• 401-901-001 : EXA Port Ping Test Failed**

EXA Port Ping Test Failed.

**Recoverable**

No

**Severity**

Error

**Serviceable**

Yes

**Automatically notify support**

No

**User Response**

Complete the following steps:

1. Remove power cables, wait for 45 seconds, reconnect and rerun the test.
2. Make sure that the scalability cable connections are as per specification.
3. Check scalability cables for loose connections.
4. Replace the scalability cable(s) for specified port(s).
5. If the problem remains, contact your technical-service representative.

**Related links**

- [IBM Support website](#)
- [Latest level of DSA](#)
- [Latest level of BMC/IMM](#)

**DSA Intel network test results**

The following messages can result when you run the Intel network test.

**Test results for the DSA Intel network test**

The following messages can result when you run the DSA Intel network test.



- **406-000-000 : IANet:Registers Test Passed**

The test passed.

**Recoverable**

No

**Severity**

Event

**Serviceable**

No

**Automatically notify support**

No

**Related links**

- [IBM Support website](#)
- [Latest level of DSA](#)
- [Latest level of BMC/IMM](#)

- **406-001-000 : IANet:EEPROM Test Passed**

The test passed.

**Recoverable**

No

**Severity**

Event

**Serviceable**

No

**Automatically notify support**

No

**Related links**

- [IBM Support website](#)
- [Latest level of DSA](#)
- [Latest level of BMC/IMM](#)

- **406-002-000 : IANet:FIFO Test Passed**

The test passed.

**Recoverable**

No

**Severity**

Event

**Serviceable**

No

**Automatically notify support**

No

**Related links**

- [IBM Support website](#)
- [Latest level of DSA](#)
- [Latest level of BMC/IMM](#)

- **406-003-000 : IANet:Interrupts Test Passed**

The test passed.

**Recoverable**

No

**Severity**

Event

**Serviceable**

No

**Automatically notify support**

No

**Related links**

- [IBM Support website](#)
- [Latest level of DSA](#)
- [Latest level of BMC/IMM](#)

- **406-004-000 : IANet:Loopback Test Passed**

The test passed.

**Recoverable**

No

**Severity**

Event

**Serviceable**

No

**Automatically notify support**

No

**Related links**

- [IBM Support website](#)
- [Latest level of DSA](#)
- [Latest level of BMC/IMM](#)

- **406-800-000 : IANet:Registers Test Aborted**

Registers test was canceled.

**Recoverable**

No

**Severity**

Warning

**Serviceable**

No

**Automatically notify support**

No

**Related links**

- [IBM Support website](#)
- [Latest level of DSA](#)
- [Latest level of BMC/IMM](#)

- **406-801-000 : IANet:EEPROM Test Aborted**

EEPROM test was canceled.

**Recoverable**

No

**Severity**

Warning

**Serviceable**

No

**Automatically notify support**

No

**Related links**

- [IBM Support website](#)
- [Latest level of DSA](#)
- [Latest level of BMC/IMM](#)

- **406-802-000 : IANet:FIFO Test Aborted**

FIFO test was canceled.

**Recoverable**

No

**Severity**

Warning

**Serviceable**

No

**Automatically notify support**

No

**Related links**

- [IBM Support website](#)
- [Latest level of DSA](#)
- [Latest level of BMC/IMM](#)

- **406-803-000 : IANet:Interrupts Test Aborted**

Interrupt test was canceled.

**Recoverable**

No

**Severity**

Warning

**Serviceable**

No

**Automatically notify support**

No

**Related links**

- [IBM Support website](#)
- [Latest level of DSA](#)
- [Latest level of BMC/IMM](#)

- **406-804-000 : IANet:Loopback Test Aborted**

Loopback test was canceled.

**Recoverable**

No

**Severity**

Warning

**Serviceable**

No

**Automatically notify support**

No

**Related links**

- [IBM Support website](#)
- [Latest level of DSA](#)
- [Latest level of BMC/IMM](#)

- **406-900-000 : IANet:Registers Test Failed**

A failure was detected during the Registers test.

**Recoverable**

No

**Severity**

Error

**Serviceable**

Yes

**Automatically notify support**

No

**User Response**

Complete the following steps:

1. Check component firmware level and upgrade if necessary. The installed firmware level can be found in the DSA Diagnostic Event Log within the Firmware/VPD section for this component.
2. Rerun the test.
3. If failure remains, refer to "Troubleshooting by symptom" in the system "Installation and Service Guide" for the next corrective action.

**Related links**

- [IBM Support website](#)
- [Latest level of DSA](#)
- [Latest level of BMC/IMM](#)

- **406-901-000 : IANet:EEPROM Test Failed**

A failure was detected during the EEPROM test.

**Recoverable**

No

**Severity**

Error

**Serviceable**

Yes

**Automatically notify support**

No

**User Response**

Complete the following steps:

1. Check component firmware level and upgrade if necessary. The installed firmware level can be found in the DSA Diagnostic Event Log within the Firmware/VPD section for this component.
2. Rerun the test.

3. If failure remains, refer to "Troubleshooting by symptom" in the system "Installation and Service Guide" for the next corrective action.

**Related links**

- [IBM Support website](#)
- [Latest level of DSA](#)
- [Latest level of BMC/IMM](#)

- **406-902-000 : IANet:FIFO Test Failed**

A failure was detected during the FIFO test.

**Recoverable**

No

**Severity**

Error

**Serviceable**

Yes

**Automatically notify support**

No

**User Response**

Complete the following steps:

1. Check component firmware level and upgrade if necessary. The installed firmware level can be found in the DSA Diagnostic Event Log within the Firmware/VPD section for this component.
2. Rerun the test.
3. If failure remains, refer to "Troubleshooting by symptom" in the system "Installation and Service Guide" for the next corrective action.

**Related links**

- [IBM Support website](#)
- [Latest level of DSA](#)
- [Latest level of BMC/IMM](#)

- **406-903-000 : IANet:Interrupts Test Failed**

A failure was detected during the Interrupt test.

**Recoverable**

No

**Severity**

Error

**Serviceable**

Yes

**Automatically notify support**

No

**User Response**

Complete the following steps:

1. Check component firmware level and upgrade if necessary. The installed firmware level can be found in the DSA Diagnostic Event Log within the Firmware/VPD section for this component.
2. Rerun the test.
3. Check interrupt assignments in the PCI Hardware section of the DSA Diagnostic Log. If the ethernet device is sharing interrupts, if possible modify the interrupt assignments using F1 Setup to assign a unique interrupt to the device.

4. Rerun the test.
5. If failure remains, refer to "Troubleshooting by symptom" in the system "Installation and Service Guide" for the next corrective action.

**Related links**

- [IBM Support website](#)
- [Latest level of DSA](#)
- [Latest level of BMC/IMM](#)

- **406-904-000 : IANet:Loopback Test Failed**

A failure was detected during the Loopback test.

**Recoverable**

No

**Severity**

Error

**Serviceable**

Yes

**Automatically notify support**

No

**User Response**

Complete the following steps:

1. Check the Ethernet cable for damage and ensure correct cable type and attachment.
2. Check component firmware level and upgrade if necessary. The installed firmware level can be found in the DSA Diagnostic Event Log within the Firmware/VPD section for this component.
3. Rerun the test.
4. If failure remains, refer to "Troubleshooting by symptom" in the system "Installation and Service Guide" for the next corrective action.

**Related links**

- [IBM Support website](#)
- [Latest level of DSA](#)
- [Latest level of BMC/IMM](#)

---

## Event messages

Use this information to review event messages and resolve many errors.

**Note:** IMM and UEFI events related to communications errors can take up to 20 minutes to be displayed in the CMM event log.

## IMM messages

When a hardware event is detected by the IMM2 on an x440 Compute Node Types 7167 and 2590, the IMM2 logs that event in the system-event log in the compute node. In addition, the IMM2 sends that event to the CMM and to the Lenovo XClarity Administrator or Flex System Manager management software (if available).

For each event code, the following fields are displayed:

**Event identifier**

A hexadecimal identifier that uniquely identifies an event or class of events. In this documentation, the event identifiers are prefixed with 0x and followed by eight characters.

**Event description**

The logged message string that appears for an event. When the event string is displayed in the system-event log, information such as a specific component is displayed. In this documentation, that additional information appears as variables, such as [arg1] or [arg2].

**Explanation**

Additional information to explain why the event occurred.

**Severity**

An indication of the level of concern for the condition. In the system-event log, the severity is abbreviated to the first character. The following severities can be displayed:

- **Info:** The event was recorded for audit purposes. This is usually a user action or a change of states that is normal behavior.
- **Warning:** The event is not as severe as an error, but if possible, the condition should be corrected before it becomes an error. It might also be a condition that requires additional monitoring or maintenance.
- **Error:** The event is a failure or critical condition that impairs service or an expected function.

**Alert Category**

Similar events are grouped in categories. The alert category is in the following format:

*severity - device component*

*severity* is one of the following severity levels:

- **Critical:** A key component in the server is no longer functioning.
- **Warning:** The event might progress to a critical level.
- **System:** The event is the result of a system error or a configuration change.

*device component* is the specific device in the compute node that caused the event to be generated.

**Serviceable**

Whether user action is required to correct the problem.

**CIM Information**

The prefix of the message ID and the sequence number that is used by the CIM message registry.

**SNMP Trap ID**

The SNMP trap ID that is found in the SNMP alert management information base (MIB).

**Automatically notify Support**

If this field is set to **Yes** and you have enabled Call Home on the Lenovo XClarity Administrator or Electronic Service Agent (ESA) on Flex System Manager management software (if available), Support will be notified automatically if the event is generated.

If the Lenovo XClarity Administrator or Flex System Manager management software is not available, you can enable Support from the CMM web interface.

While you wait for Support to call, you can perform the recommended actions for the event.

**User response**

The actions that you should perform to solve the event.

Perform the steps listed in this section in the order shown until the problem is solved. After you perform all of the actions that are described in this field, if you cannot solve the problem, contact Support.

**Note:** This list includes error codes and messages that might not apply to this machine type and model.

## List of IMM events

This section lists all messages that can be sent from the IMM.

- **40000001-00000000 : Management Controller [arg1] Network Initialization Complete.**

The IMM network subsystem initialization has completed.

**Severity**

Info

**Serviceable**

No

**Automatically notify support**

No

**Alert Category**

System - IMM Network event

**SNMP Trap ID**

37

**CIM Information**

Prefix: IMM ID: 0001

**User Response**

Information only; no action is required.

- **40000002-00000000 : Certificate Authority [arg1] has detected a [arg2] Certificate Error.**

A problem has occurred with the SSL Server, SSL Client, or SSL Trusted CA certificate that has been imported into the IMM. The imported certificate must contain a public key that corresponds to the key pair that was previously generated by the Generate a New Key and Certificate Signing Request link.

**Severity**

Error

**Serviceable**

No

**Automatically notify support**

No

**Alert Category**

System - other

**SNMP Trap ID**

22

**CIM Information**

Prefix: IMM ID: 0002

**User Response**

Make sure that the certificate that you are importing is correct and properly generated.

- **40000003-00000000 : Ethernet Data Rate modified from [arg1] to [arg2] by user [arg3].**

The specified user has changed the Ethernet data rate of the Integrated Management Module external network interface to the specified value.

**Severity**

Info

**Serviceable**

No



**Automatically notify support**

No

**Alert Category**

none

**SNMP Trap ID**

**CIM Information**

Prefix: IMM ID: 0003

**User Response**

Information only; no action is required.

- **40000004-00000000 : Ethernet Duplex setting modified from [arg1] to [arg2] by user [arg3].**

The specified user has changed the Ethernet duplex setting of the Integrated Management Module external network interface to the specified value.

**Severity**

Info

**Serviceable**

No

**Automatically notify support**

No

**Alert Category**

none

**SNMP Trap ID**

**CIM Information**

Prefix: IMM ID: 0004

**User Response**

Information only; no action is required.

- **40000005-00000000 : Ethernet MTU setting modified from [arg1] to [arg2] by user [arg3].**

The specified user has changed the Ethernet maximum transmission unit (MTU) setting of the Integrated Management Module external network interface to the specified value.

**Severity**

Info

**Serviceable**

No

**Automatically notify support**

No

**Alert Category**

none

**SNMP Trap ID**

**CIM Information**

Prefix: IMM ID: 0005

**User Response**

Information only; no action is required.

- **40000006-00000000 : Ethernet locally administered MAC address modified from [arg1] to [arg2] by user [arg3].**

The specified user has changed the Ethernet locally administered MAC address of the Integrated Management Module external network interface to the specified value.

**Severity**

Info

**Serviceable**

No

**Automatically notify support**

No

**Alert Category**

none

**SNMP Trap ID**

**CIM Information**

Prefix: IMM ID: 0006

**User Response**

Information only; no action is required.

- **40000007-00000000 : Ethernet interface [arg1] by user [arg2].**

The specified user has enabled or disabled the Ethernet interface.

**Severity**

Info

**Serviceable**

No

**Automatically notify support**

No

**Alert Category**

none

**SNMP Trap ID**

**CIM Information**

Prefix: IMM ID: 0007

**User Response**

Information only; no action is required.

- **40000008-00000000 : Hostname set to [arg1] by user [arg2].**

The specified user has changed the Integrated Management Module host name.

**Severity**

Info

**Serviceable**

No

**Automatically notify support**

No

**Alert Category**

System - IMM Network event

**SNMP Trap ID**

37

**CIM Information**

**Prefix: IMM ID:** 0008

**User Response**

Information only; no action is required.

- **40000009-00000000 : IP address of network interface modified from [arg1] to [arg2] by user [arg3].**

The specified user has changed the IP address of the Integrated Management Module external network interface to the specified value.

**Severity**

Info

**Serviceable**

No

**Automatically notify support**

No

**Alert Category**

System - IMM Network event

**SNMP Trap ID**

37

**CIM Information**

**Prefix: IMM ID:** 0009

**User Response**

Information only; no action is required.

- **4000000a-00000000 : IP subnet mask of network interface modified from [arg1] to [arg2] by user [arg3].**

The specified user has changed the subnet mask of the Integrated Management Module external network interface to the specified value.

**Severity**

Info

**Serviceable**

No

**Automatically notify support**

No

**Alert Category**

none

**SNMP Trap ID**

**CIM Information**

**Prefix: IMM ID:** 0010

**User Response**

Information only; no action is required.

- **4000000b-00000000 : IP address of default gateway modified from [arg1] to [arg2] by user [arg3].**

The specified user has changed the gateway address of the Integrated Management Module external network interface to the specified value.

**Severity**

Info

**Serviceable**

No

**Automatically notify support**

No

**Alert Category**

none

**SNMP Trap ID**

**CIM Information**

Prefix: IMM ID: 0011

**User Response**

Information only; no action is required.

- **4000000c-00000000 : OS Watchdog response [arg1] by [arg2] .**

The OS Watchdog timer has been enabled or disabled by a user.

**Severity**

Info

**Serviceable**

No

**Automatically notify support**

No

**Alert Category**

none

**SNMP Trap ID**

**CIM Information**

Prefix: IMM ID: 0012

**User Response**

Information only; no action is required.

- **4000000d-00000000 : DHCP[[arg1]] failure, no IP address assigned.**

A DHCP server has failed to assign an IP address to the IMM.

**Severity**

Warning

**Serviceable**

No

**Automatically notify support**

No

**Alert Category**

none

**SNMP Trap ID**

**CIM Information**

Prefix: IMM ID: 0013

**User Response**

Complete the following steps until the problem is solved:

1. Make sure that the IMM network cable is connected.
  2. Make sure that there is a DHCP server on the network that can assign an IP address to the IMM.
- **4000000e-00000000 : Remote Login Successful. Login ID: [arg1] from [arg2] at IP address [arg3].**

The specified user has logged in to the Integrated Management Module.

**Severity**

Info

**Serviceable**

No

**Automatically notify support**

No

**Alert Category**

System - Remote Login

**SNMP Trap ID**

30

**CIM Information**

Prefix: IMM ID: 0014

**User Response**

Information only; no action is required.

- **4000000f-00000000 : Attempting to [arg1] server [arg2] by user [arg3].**

The specified user has initiated a power function on the system using the Management Controller.

**Severity**

Info

**Serviceable**

No

**Automatically notify support**

No

**Alert Category**

none

**SNMP Trap ID****CIM Information**

Prefix: IMM ID: 0015

**User Response**

Information only; no action is required.

- **40000010-00000000 : Security: Userid: [arg1] had [arg2] login failures from WEB client at IP address [arg3].**

A user has exceeded the maximum allowed number of unsuccessful login attempts from a web browser and has been prevented from logging in for the lockout period.

**Severity**

Warning

**Serviceable**

No

**Automatically notify support**

No

**Alert Category**

System - Remote Login

**SNMP Trap ID**

30

**CIM Information**

Prefix: IMM ID: 0016

**User Response**

Complete the following steps until the problem is solved:

1. Make sure that the correct login ID and password are being used.
  2. Have the system administrator reset the login ID or password.
- **40000011-00000000 : Security: Login ID: [arg1] had [arg2] login failures from CLI at [arg3].**

A user has exceeded the maximum allowed number of unsuccessful login attempts from the command-line interface and has been prevented from logging in for the lockout period.

**Severity**

Warning

**Serviceable**

No

**Automatically notify support**

No

**Alert Category**

System - Remote Login

**SNMP Trap ID**

30

**CIM Information**

Prefix: IMM ID: 0017

**User Response**

Complete the following steps until the problem is solved:

1. Make sure that the correct login ID and password are being used.
  2. Have the system administrator reset the login ID or password.
- **40000012-00000000 : Remote access attempt failed. Invalid userid or password received. Userid is [arg1] from WEB browser at IP address [arg2].**

A user has attempted to log in from a web browser by using an invalid login ID or password.

**Severity**

Info

**Serviceable**

No

**Automatically notify support**

No

**Alert Category**

System - Remote Login

**SNMP Trap ID**

30

**CIM Information**

Prefix: IMM ID: 0018

**User Response**

Make sure that the correct login ID and password are being used.

- **40000013-00000000 : Remote access attempt failed. Invalid userid or password received. Userid is [arg1] from TELNET client at IP address [arg2].**

A user has attempted to log in from a Telnet session by using an invalid login ID or password.

**Severity**

Info

**Serviceable**

No

**Automatically notify support**

No

**Alert Category**

System - Remote Login

**SNMP Trap ID**

30

**CIM Information**

Prefix: IMM ID: 0019

**User Response**

Make sure that the correct login ID and password are being used.

- **40000014-00000000 : The [arg1] on system [arg2] cleared by user [arg3].**

The specified user has deleted system log events or audit log events.

**Severity**

Info

**Serviceable**

No

**Automatically notify support**

No

**Alert Category**

none

**SNMP Trap ID****CIM Information**

Prefix: IMM ID: 0020

**User Response**

Information only; no action is required.

- **40000015-00000000 : Management Controller [arg1] reset was initiated by user [arg2].**

The Integrated Management Module has been reset. The logs provide additional details.

**Severity**

Info

**Serviceable**

No

**Automatically notify support**

No

**Alert Category**

none

**SNMP Trap ID****CIM Information**

Prefix: IMM ID: 0021

**User Response**

Information only; no action is required.

- **40000016-00000000 : ENET[[arg1]] DHCP-HSTN=[arg2], DN=[arg3], IP@=[arg4], SN=[arg5], GW@=[arg6], DNS1@=[arg7] .**

The DHCP server has assigned an IMM IP address and configuration.

**Severity**

Info

**Serviceable**

No

**Automatically notify support**

No

**Alert Category**

none

**SNMP Trap ID****CIM Information**

Prefix: IMM ID: 0022

**User Response**

Information only; no action is required.

- **40000017-00000000 : ENET[[arg1]] IP-Cfg:HstName=[arg2], IP@=[arg3] ,NetMsk=[arg4], GW@=[arg5] .**

An IMM IP address and configuration have been assigned using client data.

**Severity**

Info

**Serviceable**

No

**Automatically notify support**

No

**Alert Category**

none

**SNMP Trap ID**



**CIM Information**

Prefix: IMM ID: 0023

**User Response**

Information only; no action is required.

- **40000018-00000000 : LAN: Ethernet[[arg1]] interface is no longer active.**

The IMM Ethernet interface has been disabled.

**Severity**

Info

**Serviceable**

No

**Automatically notify support**

No

**Alert Category**

none

**SNMP Trap ID****CIM Information**

Prefix: IMM ID: 0024

**User Response**

Information only; no action is required.

- **40000019-00000000 : LAN: Ethernet[[arg1]] interface is now active.**

The IMM Ethernet interface has been enabled.

**Severity**

Info

**Serviceable**

No

**Automatically notify support**

No

**Alert Category**

none

**SNMP Trap ID****CIM Information**

Prefix: IMM ID: 0025

**User Response**

Information only; no action is required.

- **4000001a-00000000 : DHCP setting changed to [arg1] by user [arg2].**

The specified user has changed the DHCP setting of the Integrated Management Module external network interface.

**Severity**

Info

**Serviceable**

No

**Automatically notify support**

No

**Alert Category**

none

**SNMP Trap ID****CIM Information**

Prefix: IMM ID: 0026

**User Response**

Information only; no action is required.

- **4000001b-00000000 : Management Controller [arg1]: Configuration restored from a file by user [arg2].**

The specified user has restored the Integrated Management Module (IMM) configuration from a previously saved configuration file. Some configuration settings might require that the IMM be restarted before they take effect.

**Severity**

Info

**Serviceable**

No

**Automatically notify support**

No

**Alert Category**

none

**SNMP Trap ID****CIM Information**

Prefix: IMM ID: 0027

**User Response**

Information only; no action is required.

- **4000001c-00000000 : Watchdog [arg1] Screen Capture Occurred.**

An operating-system error has occurred, and the screen capture was successful.

**Severity**

Info

**Serviceable**

No

**Automatically notify support**

No

**Alert Category**

System - other

**SNMP Trap ID**

22

**CIM Information**

Prefix: IMM ID: 0028

**User Response**

If there was no operating-system error, complete the following steps until the problem is solved:

1. Reconfigure the watchdog timer to a higher value.
2. Make sure that the IMM Ethernet-over-USB interface is enabled.
3. Reinstall the RNDIS or cdc\_ether device driver for the operating system.
4. Disable the watchdog.

If there was an operating-system error, check the integrity of the installed operating system.

#### Related links

- "Installing the LAN over USB Linux device driver" on page 50
- "Installing the LAN over USB Windows device driver" on page 49

- **4000001d-00000000 : Watchdog [arg1] Failed to Capture Screen.**

An operating-system error has occurred, and the screen capture failed.

#### Severity

Error

#### Serviceable

No

#### Automatically notify support

No

#### Alert Category

System - other

#### SNMP Trap ID

22

#### CIM Information

Prefix: IMM ID: 0029

#### User Response

Complete the following steps until the problem is solved:

1. Reconfigure the watchdog timer to a higher value.
2. Make sure that the IMM Ethernet over USB interface is enabled.
3. Reinstall the RNDIS or cdc\_ether device driver for the operating system.
4. Disable the watchdog.
5. Check the integrity of the installed operating system.
6. Update the IMM firmware. **Important:** Some cluster solutions require specific code levels or coordinated code updates. If the device is part of a cluster solution, verify that the latest level of code is supported for the cluster solution before you update the code.

#### Related links

- "Installing the LAN over USB Linux device driver" on page 50
- "Installing the LAN over USB Windows device driver" on page 49

- **4000001e-00000000 : Running the backup Management Controller [arg1] main application.**

The IMM was unable to run the primary IMM image and has resorted to running the backup image.

#### Severity

Warning

#### Serviceable

No

#### Automatically notify support

No

**Alert Category**

System - other

**SNMP Trap ID**

22

**CIM Information**

Prefix: IMM ID: 0030

**User Response**

Update the IMM firmware. **Important:** Some cluster solutions require specific code levels or coordinated code updates. If the device is part of a cluster solution, verify that the latest level of code is supported for the cluster solution before you update the code.

**Related links**

- "Updating firmware and device drivers" on page 23
- IBM Flex System and IBM PureFlex Firmware Updates Best Practices
- **4000001f-00000000 : Please ensure that the Management Controller [arg1] is flashed with the correct firmware. The Management Controller is unable to match its firmware to the server.**

The server does not support the installed IMM firmware version.

**Severity**

Error

**Serviceable**

No

**Automatically notify support**

No

**Alert Category**

System - other

**SNMP Trap ID**

22

**CIM Information**

Prefix: IMM ID: 0031

**User Response**

Update the IMM firmware to a version that the server supports. **Important:** Some cluster solutions require specific code levels or coordinated code updates. If the device is part of a cluster solution, verify that the latest level of code is supported for the cluster solution before you update the code.

**Related links**

- "Updating firmware and device drivers" on page 23
- IBM Flex System and IBM PureFlex Firmware Updates Best Practices
- **40000020-00000000 : Management Controller [arg1] Reset was caused by restoring default values.**

The default configuration has been restored to the Integrated Management Module.

**Severity**

Info

**Serviceable**

No

**Automatically notify support**

No

**Alert Category**

none

**SNMP Trap ID**

**CIM Information**

**Prefix: IMM ID:** 0032

**User Response**

Information only; no action is required.

- **40000021-00000000 : Management Controller [arg1] clock has been set from NTP server [arg2].**

The IMM clock has been set to the date and time that are provided by the Network Time Protocol server.

**Severity**

Info

**Serviceable**

No

**Automatically notify support**

No

**Alert Category**

none

**SNMP Trap ID**

**CIM Information**

**Prefix: IMM ID:** 0033

**User Response**

Information only; no action is required.

- **40000022-00000000 : SSL data in the Management Controller [arg1] configuration data is invalid. Clearing configuration data region and disabling SSL.**

There is a problem with the certificate that has been imported into the IMM. The imported certificate must contain a public key that corresponds to the key pair that was previously generated through the Generate a New Key and Certificate Signing Request link.

**Severity**

Error

**Serviceable**

No

**Automatically notify support**

No

**Alert Category**

System - other

**SNMP Trap ID**

22

**CIM Information**

**Prefix: IMM ID:** 0034

**User Response**

Complete the following steps until the problem is solved:

1. Make sure that the certificate that you are importing is correct.
2. Try to import the certificate again.

- **40000023-00000000 : Flash of [arg1] from [arg2] succeeded for user [arg3] .**

The specified firmware update has been completed.

**Severity**

Info

**Serviceable**

No

**Automatically notify support**

No

**Alert Category**

none

**SNMP Trap ID**

**CIM Information**

Prefix: IMM ID: 0035

**User Response**

Information only; no action is required.

- **40000024-00000000 : Flash of [arg1] from [arg2] failed for user [arg3].**

The specified firmware has not been updated.

**Severity**

Info

**Serviceable**

No

**Automatically notify support**

No

**Alert Category**

System - other

**SNMP Trap ID**

22

**CIM Information**

Prefix: IMM ID: 0036

**User Response**

Information only; no action is required.

- **40000025-00000000 : The [arg1] on system [arg2] is 75% full.**

The IMM event log is 75% full. When the event log is completely full, the new entries will overwrite the oldest entries. To avoid losing older log entries, save the log as a text file and clear the log.

**Severity**

Info

**Serviceable**

No

**Automatically notify support**

No

**Alert Category**

System - Event Log Fullness

**SNMP Trap ID**

35

**CIM Information****Prefix: IMM ID: 0037****User Response**

Information only; no action is required.

- **40000026-00000000 : The [arg1] on system [arg2] is 100% full.**

The IMM event log is full. New entries in the log will overwrite the oldest entries. To avoid losing older log entries, save the log as a text file and clear the log.

**Severity**

Info

**Serviceable**

No

**Automatically notify support**

No

**Alert Category**

System - Event Log Fullness

**SNMP Trap ID**

35

**CIM Information****Prefix: IMM ID: 0038****User Response**

To avoid losing older log entries, save the log as a text file and clear the log.

- **40000027-00000000 : Platform Watchdog Timer expired for [arg1].**

A Platform Watchdog Timer Expired event has occurred.

**Severity**

Error

**Serviceable**

No

**Automatically notify support**

No

**Alert Category**

System - OS Timeout

**SNMP Trap ID**

21

**CIM Information****Prefix: IMM ID: 0039****User Response**

Complete the following steps until the problem is solved:

1. Reconfigure the watchdog timer to a higher value.
2. Make sure that the IMM Ethernet-over-USB interface is enabled.
3. Reinstall the RNDIS or cdc\_ether device driver for the operating system.
4. Disable the watchdog.

5. Check the integrity of the installed operating system.

**Related links**

- "Installing the LAN over USB Linux device driver" on page 50
- "Installing the LAN over USB Windows device driver" on page 49

- **40000028-00000000 : Management Controller Test Alert Generated by [arg1].**

The Integrated Management Module has sent a test message to help verify connectivity.

**Severity**

Info

**Serviceable**

No

**Automatically notify support**

No

**Alert Category**

System - other

**SNMP Trap ID**

22

**CIM Information**

Prefix: IMM ID: 0040

**User Response**

Information only; no action is required.

- **40000029-00000000 : Security: Userid: [arg1] had [arg2] login failures from an SSH client at IP address [arg3].**

A user has exceeded the maximum allowed number of unsuccessful login attempts from SSH and has been prevented from logging in for the lockout period.

**Severity**

Info

**Serviceable**

No

**Automatically notify support**

No

**Alert Category**

System - Remote Login

**SNMP Trap ID**

30

**CIM Information**

Prefix: IMM ID: 0041

**User Response**

Complete the following steps until the problem is solved:

1. Make sure that the correct login ID and password are being used.
2. Have the system administrator reset the login ID or password.

- **4000002a-00000000 : [arg1] firmware mismatch internal to system [arg2]. Please attempt to flash the [arg3] firmware.**

A specific type of firmware mismatch has been detected.

**Severity**



Error

**Serviceable**

No

**Automatically notify support**

No

**Alert Category**

System - Other

**SNMP Trap ID**

22

**CIM Information**

**Prefix: IMM ID:** 0042

**User Response**

Update the IMM firmware to the latest version.

**Related links**

- "Updating firmware and device drivers" on page 23
- IBM Flex System and IBM PureFlex Firmware Updates Best Practices

• **4000002b-00000000 : Domain name set to [arg1].**

Domain name set by user.

**Severity**

Info

**Serviceable**

No

**Automatically notify support**

No

**Alert Category**

none

**SNMP Trap ID**

**CIM Information**

**Prefix: IMM ID:** 0043

**User Response**

Information only; no action is required.

• **4000002c-00000000 : Domain Source changed to [arg1] by user [arg2].**

Domain source changed by user.

**Severity**

Info

**Serviceable**

No

**Automatically notify support**

No

**Alert Category**

none

**SNMP Trap ID**

**CIM Information**

Prefix: IMM ID: 0044

**User Response**

Information only; no action is required.

- **4000002d-00000000 : DDNS setting changed to [arg1] by user [arg2].**

DDNS setting changed by user.

**Severity**

Info

**Serviceable**

No

**Automatically notify support**

No

**Alert Category**

none

**SNMP Trap ID****CIM Information**

Prefix: IMM ID: 0045

**User Response**

Information only; no action is required.

- **4000002e-00000000 : DDNS registration successful. The domain name is [arg1].**

The DDNS registration was successful.

**Severity**

Info

**Serviceable**

No

**Automatically notify support**

No

**Alert Category**

none

**SNMP Trap ID****CIM Information**

Prefix: IMM ID: 0046

**User Response**

Information only; no action is required.

- **4000002f-00000000 : IPv6 enabled by user [arg1] .**

The specified user has enabled IPv6 support on the Integrated Management Module.

**Severity**

Info

**Serviceable**

No

**Automatically notify support**

No

**Alert Category**

none

**SNMP Trap ID**

**CIM Information**

Prefix: IMM ID: 0047

**User Response**

Information only; no action is required.

- **40000030-00000000 : IPv6 disabled by user [arg1] .**

The specified user has disabled IPv6 support on the Integrated Management Module.

**Severity**

Info

**Serviceable**

No

**Automatically notify support**

No

**Alert Category**

none

**SNMP Trap ID**

**CIM Information**

Prefix: IMM ID: 0048

**User Response**

Information only; no action is required.

- **40000031-00000000 : IPv6 static IP configuration enabled by user [arg1].**

The specified user has enabled IPv6 static address assignment on the Integrated Management Module.

**Severity**

Info

**Serviceable**

No

**Automatically notify support**

No

**Alert Category**

none

**SNMP Trap ID**

**CIM Information**

Prefix: IMM ID: 0049

**User Response**

Information only; no action is required.

- **40000032-00000000 : IPv6 DHCP enabled by user [arg1].**

The specified user has enabled DHCPv6 on the Integrated Management Module.

**Severity**

Info

**Serviceable**

No

**Automatically notify support**

No

**Alert Category**

none

**SNMP Trap ID****CIM Information**

Prefix: IMM ID: 0050

**User Response**

Information only; no action is required.

- **40000033-00000000 : IPv6 stateless auto-configuration enabled by user [arg1].**

IPv6 stateless address auto-configuration has been enabled on the Integrated Management Module by the specified user.

**Severity**

Info

**Serviceable**

No

**Automatically notify support**

No

**Alert Category**

none

**SNMP Trap ID****CIM Information**

Prefix: IMM ID: 0051

**User Response**

Information only; no action is required.

- **40000034-00000000 : IPv6 static IP configuration disabled by user [arg1].**

The specified user has disabled IPv6 static address assignment on the Integrated Management Module.

**Severity**

Info

**Serviceable**

No

**Automatically notify support**

No

**Alert Category**

none

**SNMP Trap ID****CIM Information**

**Prefix: IMM ID: 0052**

**User Response**

Information only; no action is required.

- **40000035-00000000 : IPv6 DHCP disabled by user [arg1].**

The specified user has disabled DHCPv6 on the Integrated Management Module.

**Severity**

Info

**Serviceable**

No

**Automatically notify support**

No

**Alert Category**

none

**SNMP Trap ID**

**CIM Information**

**Prefix: IMM ID: 0053**

**User Response**

Information only; no action is required.

- **40000036-00000000 : IPv6 stateless auto-configuration disabled by user [arg1].**

IPv6 stateless address auto-configuration has been disabled on the Integrated Management Module by the specified user.

**Severity**

Info

**Serviceable**

No

**Automatically notify support**

No

**Alert Category**

none

**SNMP Trap ID**

**CIM Information**

**Prefix: IMM ID: 0054**

**User Response**

Information only; no action is required.

- **40000037-00000000 : ENET[[arg1]] IPv6-LinkLocal:HstName=[arg2], IP@[arg3], Pref=[arg4] .**

The IPv6 link-local address is active.

**Severity**

Info

**Serviceable**

No

**Automatically notify support**

No

**Alert Category**

none

**SNMP Trap ID**

**CIM Information**

Prefix: IMM ID: 0055

**User Response**

Information only; no action is required.

- **40000038-00000000 : ENET[[arg1]] IPv6-Static:HstName=[arg2], IP@[arg3], Pref=[arg4], GW@[arg5].**

The IPv6 static address is active.

**Severity**

Info

**Serviceable**

No

**Automatically notify support**

No

**Alert Category**

none

**SNMP Trap ID**

**CIM Information**

Prefix: IMM ID: 0056

**User Response**

Information only; no action is required.

- **40000039-00000000 : ENET[[arg1]] DHCPv6-HSTN=[arg2], DN=[arg3], IP@[arg4], Pref=[arg5].**

The IPv6 DHCP-assigned address is active.

**Severity**

Info

**Serviceable**

No

**Automatically notify support**

No

**Alert Category**

none

**SNMP Trap ID**

**CIM Information**

Prefix: IMM ID: 0057

**User Response**

Information only; no action is required.

- **4000003a-00000000 : IPv6 static address of network interface modified from [arg1] to [arg2] by user [arg3].**

A user has modified the IPv6 static address of a Management Controller.

**Severity**

Info

**Serviceable**

No

**Automatically notify support**

No

**Alert Category**

none

**SNMP Trap ID**

**CIM Information**

Prefix: IMM ID: 0058

**User Response**

Information only; no action is required.

- **4000003b-00000000 : DHCPv6 failure, no IP address assigned.**

The DHCPv6 server has failed to assign an IP address to a management controller.

**Severity**

Warning

**Serviceable**

No

**Automatically notify support**

No

**Alert Category**

none

**SNMP Trap ID**

**CIM Information**

Prefix: IMM ID: 0059

**User Response**

Complete the following steps until the problem is solved:

1. Make sure that the IMM network cable is connected.
2. Make sure that there is a DHCPv6 server on the network that can assign an IP address to the IMM.

- **4000003c-00000000 : Platform Watchdog Timer expired for [arg1].**

IMM has detected an OS did not start in the expected amount of time.

**Severity**

Error

**Serviceable**

No

**Automatically notify support**

No

**Alert Category**

System - Loader timeout

**SNMP Trap ID**

26

**CIM Information**

**Prefix: IMM ID:** 0060

**User Response**

1. Reconfigure the watchdog timer to a higher value.
2. Make sure that the IMM Ethernet over USB interface is enabled.
3. Reinstall the RNDIS or cdc\_ether device driver for the operating system.
4. Disable the watchdog.
5. Check the integrity of the installed operating system

**Related links**

- "Installing the LAN over USB Linux device driver" on page 50
- "Installing the LAN over USB Windows device driver" on page 49

- **4000003d-00000000 : Telnet port number changed from [arg1] to [arg2] by user [arg3].**

The specified user has changed the Telnet port number.

**Severity**

Info

**Serviceable**

No

**Automatically notify support**

No

**Alert Category**

none

**SNMP Trap ID**

**CIM Information**

**Prefix: IMM ID:** 0061

**User Response**

Information only; no action is required.

- **4000003e-00000000 : SSH port number changed from [arg1] to [arg2] by user [arg3].**

The specified user has changed the Secure Shell (SSH) port number.

**Severity**

Info

**Serviceable**

No

**Automatically notify support**

No

**Alert Category**

none

**SNMP Trap ID**

**CIM Information**



**Prefix: IMM ID: 0062**

**User Response**

Information only; no action is required.

- **4000003f-00000000 : Web-HTTP port number changed from [arg1] to [arg2] by user [arg3].**

The specified user has changed the HTTP port number. New HTTP (web) connections must use the new port number.

**Severity**

Info

**Serviceable**

No

**Automatically notify support**

No

**Alert Category**

none

**SNMP Trap ID**

**CIM Information**

**Prefix: IMM ID: 0063**

**User Response**

Information only; no action is required.

- **40000040-00000000 : Web-HTTPS port number changed from [arg1] to [arg2] by user [arg3].**

The specified user has changed the HTTPS port number. New HTTPS (secure web) connections must use the new port number.

**Severity**

Info

**Serviceable**

No

**Automatically notify support**

No

**Alert Category**

none

**SNMP Trap ID**

**CIM Information**

**Prefix: IMM ID: 0064**

**User Response**

Information only; no action is required.

- **40000041-00000000 : CIM/XML HTTP port number changed from [arg1] to [arg2] by user [arg3].**

The specified user has changed the CIM HTTP port number.

**Severity**

Info

**Serviceable**

No

**Automatically notify support**

No

**Alert Category**

none

**SNMP Trap ID**

**CIM Information**

Prefix: IMM ID: 0065

**User Response**

Information only; no action is required.

- **40000042-00000000 : CIM/XML HTTPS port number changed from [arg1] to [arg2] by user [arg3].**

The specified user has changed the CIM HTTPS port number.

**Severity**

Info

**Serviceable**

No

**Automatically notify support**

No

**Alert Category**

none

**SNMP Trap ID**

**CIM Information**

Prefix: IMM ID: 0066

**User Response**

Information only; no action is required.

- **40000043-00000000 : SNMP Agent port number changed from [arg1] to [arg2] by user [arg3].**

The specified user has changed the Simple Network Management Protocol (SNMP) agent port number.

**Severity**

Info

**Serviceable**

No

**Automatically notify support**

No

**Alert Category**

none

**SNMP Trap ID**

**CIM Information**

Prefix: IMM ID: 0067

**User Response**

Information only; no action is required.

- **40000044-00000000 : SNMP Traps port number changed from [arg1] to [arg2] by user [arg3].**

The specified user has changed the Simple Network Management Protocol (SNMP) traps port number.

**Severity**

Info

**Serviceable**

No

**Automatically notify support**

No

**Alert Category**

none

**SNMP Trap ID****CIM Information**

Prefix: IMM ID: 0068

**User Response**

Information only; no action is required.

- **40000045-00000000 : Syslog port number changed from [arg1] to [arg2] by user [arg3].**

A user has modified the Syslog receiver port number.

**Severity**

Info

**Serviceable**

No

**Automatically notify support**

No

**Alert Category**

none

**SNMP Trap ID****CIM Information**

Prefix: IMM ID: 0069

**User Response**

Information only; no action is required.

- **40000046-00000000 : Remote Presence port number changed from [arg1] to [arg2] by user [arg3].**

A user has modified the Remote Presence port number.

**Severity**

Info

**Serviceable**

No

**Automatically notify support**

No

**Alert Category**

none

**SNMP Trap ID****CIM Information**

Prefix: IMM ID: 0070

**User Response**

Information only; no action is required.

- **40000047-00000000 : LED [arg1] state changed to [arg2] by [arg3].**

The specified LED has changed state.

**Severity**

Info

**Serviceable**

No

**Automatically notify support**

No

**Alert Category**

none

**SNMP Trap ID****CIM Information**

Prefix: IMM ID: 0071

**User Response**

Information only; no action is required.

- **40000048-00000000 : Inventory data changed for device [arg1], new device data hash=[arg2], new master data hash=[arg3] .**

The physical inventory has changed.

**Severity**

Info

**Serviceable**

No

**Automatically notify support**

No

**Alert Category**

none

**SNMP Trap ID****CIM Information**

Prefix: IMM ID: 0072

**User Response**

Information only; no action is required.

- **40000049-00000000 : SNMP [arg1] enabled by user [arg2] .**

The specified user has enabled the SNMPv1 or SNMPv3 agent.

**Severity**

Info

**Serviceable**

No

**Automatically notify support**

No

**Alert Category**

none

**SNMP Trap ID****CIM Information**

Prefix: IMM ID: 0073

**User Response**

Information only; no action is required.

- **4000004a-00000000 : SNMP [arg1] disabled by user [arg2] .**

The specified user has disabled the SNMPv1 or SNMPv3 agent.

**Severity**

Info

**Serviceable**

No

**Automatically notify support**

No

**Alert Category**

none

**SNMP Trap ID****CIM Information**

Prefix: IMM ID: 0074

**User Response**

Information only; no action is required.

- **4000004b-00000000 : SNMPv1 [arg1] set by user [arg2]: Name=[arg3], AccessType=[arg4], Address=[arg5], .**

A user changed the SNMP community string.

**Severity**

Info

**Serviceable**

No

**Automatically notify support**

No

**Alert Category**

none

**SNMP Trap ID****CIM Information**

Prefix: IMM ID: 0075

**User Response**

Information only; no action is required.

- **4000004c-00000000 : LDAP Server configuration set by user [arg1]: SelectionMethod=[arg2], DomainName=[arg3], Server1=[arg4], Server2=[arg5], Server3=[arg6], Server4=[arg7].**

A user changed the LDAP server configuration.

**Severity**

Info

**Serviceable**

No

**Automatically notify support**

No

**Alert Category**

none

**SNMP Trap ID****CIM Information**

Prefix: IMM ID: 0076

**User Response**

Information only; no action is required.

- **4000004d-00000000 : LDAP set by user [arg1]: RootDN=[arg2], UIDSearchAttribute=[arg3], BindingMethod=[arg4], EnhancedRBS=[arg5], TargetName=[arg6], GroupFilter=[arg7], GroupAttribute=[arg8], LoginAttribute=[arg9].**

A user configured an LDAP Miscellaneous setting.

**Severity**

Info

**Serviceable**

No

**Automatically notify support**

No

**Alert Category**

none

**SNMP Trap ID****CIM Information**

Prefix: IMM ID: 0077

**User Response**

Information only; no action is required.

- **4000004e-00000000 : Serial Redirection set by user [arg1]: Mode=[arg2], BaudRate=[arg3], StopBits=[arg4], Parity=[arg5], SessionTerminateSequence=[arg6].**

A user configured the Serial Port mode.

**Severity**

Info

**Serviceable**

No

**Automatically notify support**

No

**Alert Category**

none

**SNMP Trap ID**

**CIM Information**

Prefix: IMM ID: 0078

**User Response**

Information only; no action is required.

- **4000004f-00000000 : Date and Time set by user [arg1]: Date=[arg2], Time=[arg3], DST Auto-adjust=[arg4], Timezone=[arg5].**

The specified user has changed the date and time in the Integrated Management Module.

**Severity**

Info

**Serviceable**

No

**Automatically notify support**

No

**Alert Category**

none

**SNMP Trap ID****CIM Information**

Prefix: IMM ID: 0079

**User Response**

Information only; no action is required.

- **40000050-00000000 : Server General Settings set by user [arg1]: Name=[arg2], Contact=[arg3], Location=[arg4], Room=[arg5], RackID=[arg6], Rack U-position=[arg7].**

A user configured the Location setting.

**Severity**

Info

**Serviceable**

No

**Automatically notify support**

No

**Alert Category**

none

**SNMP Trap ID****CIM Information**

Prefix: IMM ID: 0080

**User Response**

Information only; no action is required.

- **40000051-00000000 : Server Power Off Delay set to [arg1] by user [arg2].**

A user configured the Server Power Off Delay.

**Severity**

Info

**Serviceable**

No

**Automatically notify support**

No

**Alert Category**

none

**SNMP Trap ID****CIM Information**

Prefix: IMM ID: 0081

**User Response**

Information only; no action is required.

- **40000052-00000000 : Server [arg1] scheduled for [arg2] at [arg3] by user [arg4].**

A user configured a Server Power action at a specific time.

**Severity**

Info

**Serviceable**

No

**Automatically notify support**

No

**Alert Category**

none

**SNMP Trap ID****CIM Information**

Prefix: IMM ID: 0082

**User Response**

Information only; no action is required.

- **40000053-00000000 : Server [arg1] scheduled for every [arg2] at [arg3] by user [arg4].**

A user configured a recurring Server Power Action.

**Severity**

Info

**Serviceable**

No

**Automatically notify support**

No

**Alert Category**

none

**SNMP Trap ID****CIM Information**

Prefix: IMM ID: 0083

**User Response**

Information only; no action is required.



- **40000054-00000000 : Server [arg1] [arg2] cleared by user [arg3].**

A user cleared a Server Power Action.

**Severity**

Info

**Serviceable**

No

**Automatically notify support**

No

**Alert Category**

none

**SNMP Trap ID**

**CIM Information**

Prefix: IMM ID: 0084

**User Response**

Information only; no action is required.

- **40000055-00000000 : Synchronize time setting by user [arg1]: Mode=[arg2], NTPServerHost1=[arg3]:[arg4], NTPServerHost2=[arg5]:[arg6], NTPServerHost3=[arg7]:[arg8], NTPServerHost4=[arg9]:[arg10], NTPUpdateFrequency=[arg11].**

A user configured the Date and Time synchronize settings.

**Severity**

Info

**Serviceable**

No

**Automatically notify support**

No

**Alert Category**

none

**SNMP Trap ID**

**CIM Information**

Prefix: IMM ID: 0085

**User Response**

Information only; no action is required.

- **40000056-00000000 : SMTP Server set by user [arg1] to [arg2]:[arg3].**

A user configured the SMTP server.

**Severity**

Info

**Serviceable**

No

**Automatically notify support**

No

**Alert Category**

none

#### **SNMP Trap ID**

#### **CIM Information**

Prefix: IMM ID: 0086

#### **User Response**

Information only; no action is required.

- **40000057-00000000 : Telnet [arg1] by user [arg2].**

The specified user has enabled or disabled Telnet.

#### **Severity**

Info

#### **Serviceable**

No

#### **Automatically notify support**

No

#### **Alert Category**

none

#### **SNMP Trap ID**

#### **CIM Information**

Prefix: IMM ID: 0087

#### **User Response**

Information only; no action is required.

- **40000058-00000000 : DNS servers set by user [arg1]: UseAdditionalServers=[arg2], PreferredDNStype=[arg3], IPv4Server1=[arg4], IPv4Server2=[arg5], IPv4Server3=[arg6], IPv6Server1=[arg7], IPv6Server2=[arg8], IPv6Server3=[arg9].**

The specified user has configured the DNS servers.

#### **Severity**

Info

#### **Serviceable**

No

#### **Automatically notify support**

No

#### **Alert Category**

none

#### **SNMP Trap ID**

#### **CIM Information**

Prefix: IMM ID: 0088

#### **User Response**

Information only; no action is required.

- **40000059-00000000 : LAN over USB [arg1] by user [arg2].**

A user configured USB-LAN.

**Severity**

Info

**Serviceable**

No

**Automatically notify support**

No

**Alert Category**

none

**SNMP Trap ID****CIM Information**

Prefix: IMM ID: 0089

**User Response**

Information only; no action is required.

- **4000005a-00000000 : LAN over USB Port Forwarding set by user [arg1]: ExternalPort=[arg2], USB-LAN port=[arg3].**

A user configured USB-LAN port forwarding.

**Severity**

Info

**Serviceable**

No

**Automatically notify support**

No

**Alert Category**

none

**SNMP Trap ID****CIM Information**

Prefix: IMM ID: 0090

**User Response**

Information only; no action is required.

- **4000005b-00000000 : Secure Web services (HTTPS) [arg1] by user [arg2].**

A user enables or disables Secure web services.

**Severity**

Info

**Serviceable**

No

**Automatically notify support**

No

**Alert Category**

none

**SNMP Trap ID****CIM Information**

**Prefix: IMM ID: 0091**

**User Response**

Information only; no action is required.

- **4000005c-00000000 : Secure CIM/XML(HTTPS) [arg1] by user [arg2].**

The secure CIM-XML port has been enabled or disabled.

**Severity**

Info

**Serviceable**

No

**Automatically notify support**

No

**Alert Category**

none

**SNMP Trap ID**

**CIM Information**

**Prefix: IMM ID: 0092**

**User Response**

Information only; no action is required.

- **4000005d-00000000 : Secure LDAP [arg1] by user [arg2].**

A user enables or disables Secure LDAP services.

**Severity**

Info

**Serviceable**

No

**Automatically notify support**

No

**Alert Category**

none

**SNMP Trap ID**

**CIM Information**

**Prefix: IMM ID: 0093**

**User Response**

Information only; no action is required.

- **4000005e-00000000 : SSH [arg1] by user [arg2].**

The specified user has enabled or disabled the Secure Shell (SSH) service.

**Severity**

Info

**Serviceable**

No

**Automatically notify support**

No

**Alert Category**

none

**SNMP Trap ID****CIM Information**

Prefix: IMM ID: 0094

**User Response**

Information only; no action is required.

- **4000005f-00000000 : Server timeouts set by user [arg1]: EnableOSWatchdog=[arg2], OSWatchdogTimeout=[arg3], EnableLoaderWatchdog=[arg4], LoaderTimeout=[arg5].**

A user configures Server Timeouts.

**Severity**

Info

**Serviceable**

No

**Automatically notify support**

No

**Alert Category**

none

**SNMP Trap ID****CIM Information**

Prefix: IMM ID: 0095

**User Response**

Information only; no action is required.

- **40000060-00000000 : License key for [arg1] added by user [arg2].**

A Integrated Management Module license that allows access to the specified feature was added to the system.

**Severity**

Info

**Serviceable**

No

**Automatically notify support**

No

**Alert Category**

none

**SNMP Trap ID****CIM Information**

Prefix: IMM ID: 0096

**User Response**

Information only; no action is required.

- **40000061-00000000 : License key for [arg1] removed by user [arg2].**

The specified user has removed an Integrated Management Module license. Access to the specified feature is no longer allowed.

**Severity**

Info

**Serviceable**

No

**Automatically notify support**

No

**Alert Category**

none

**SNMP Trap ID**

**CIM Information**

Prefix: IMM ID: 0097

**User Response**

Information only; no action is required.

- **40000062-00000000 : Global Login General Settings set by user [arg1]: AuthenticationMethod=[arg2], LockoutPeriod=[arg3], SessionTimeout=[arg4].**

A user changes the Global Login General Settings.

**Severity**

Info

**Serviceable**

No

**Automatically notify support**

No

**Alert Category**

none

**SNMP Trap ID**

**CIM Information**

Prefix: IMM ID: 0098

**User Response**

Information only; no action is required.

- **40000063-00000000 : Global Login Account Security set by user [arg1]: PasswordRequired=[arg2], PasswordExpirationPeriod=[arg3], MinimumPasswordReuseCycle=[arg4], MinimumPasswordLength=[arg5], MinimumPasswordChangeInterval=[arg6], MaxmumLoginFailures=[arg7], LockoutAfterMaxFailures=[arg8], MinimumDifferentCharacters=[arg9], DefaultIDExpired=[arg10], ChangePasswordFirstAccess=[arg11].**

A user changes the Global Login Account Security Settings to Legacy.

**Severity**

Info

**Serviceable**

No

**Automatically notify support**

No

**Alert Category**

none

**SNMP Trap ID**

**CIM Information**

Prefix: IMM ID: 0099

**User Response**

Information only; no action is required.

- **40000064-00000000 : User [arg1] created.**

A user account has been created.

**Severity**

Info

**Serviceable**

No

**Automatically notify support**

No

**Alert Category**

none

**SNMP Trap ID**

**CIM Information**

Prefix: IMM ID: 0100

**User Response**

Information only; no action is required.

- **40000065-00000000 : User [arg1] removed.**

A user account has been removed.

**Severity**

Info

**Serviceable**

No

**Automatically notify support**

No

**Alert Category**

none

**SNMP Trap ID**

**CIM Information**

Prefix: IMM ID: 0101

**User Response**

Information only; no action is required.

- **40000066-00000000 : User [arg1] password modified.**

The password for the specified user account has been changed.

**Severity**

Info

**Serviceable**

No

**Automatically notify support**

No

**Alert Category**

none

**SNMP Trap ID****CIM Information**

Prefix: IMM ID: 0102

**User Response**

Information only; no action is required.

- **40000067-00000000 : User [arg1] role set to [arg2].**

A user account role assigned.

**Severity**

Info

**Serviceable**

No

**Automatically notify support**

No

**Alert Category**

none

**SNMP Trap ID****CIM Information**

Prefix: IMM ID: 0103

**User Response**

Information only; no action is required.

- **40000068-00000000 : User [arg1] custom privileges set: [arg2].**

User account privileges assigned.

**Severity**

Info

**Serviceable**

No

**Automatically notify support**

No

**Alert Category**

none

**SNMP Trap ID****CIM Information**

Prefix: IMM ID: 0104



**User Response**

Information only; no action is required.

- **40000069-00000000 : User [arg1] for SNMPv3 set: AuthenticationProtocol=[arg2], PrivacyProtocol=[arg3], AccessType=[arg4], HostforTraps=[arg5].**

User account SNMPv3 settings changed.

**Severity**

Info

**Serviceable**

No

**Automatically notify support**

No

**Alert Category**

none

**SNMP Trap ID****CIM Information**

Prefix: IMM ID: 0105

**User Response**

Information only; no action is required.

- **4000006a-00000000 : SSH Client key added for user [arg1].**

User locally defined an SSH Client key.

**Severity**

Info

**Serviceable**

No

**Automatically notify support**

No

**Alert Category**

none

**SNMP Trap ID****CIM Information**

Prefix: IMM ID: 0106

**User Response**

Information only; no action is required.

- **4000006b-00000000 : SSH Client key imported for user [arg1] from [arg2].**

User imported an SSH Client key.

**Severity**

Info

**Serviceable**

No

**Automatically notify support**

No

**Alert Category**

none

**SNMP Trap ID****CIM Information**

Prefix: IMM ID: 0107

**User Response**

Information only; no action is required.

- **4000006c-00000000 : SSH Client key removed from user [arg1].**

User removed an SSH Client key.

**Severity**

Info

**Serviceable**

No

**Automatically notify support**

No

**Alert Category**

none

**SNMP Trap ID****CIM Information**

Prefix: IMM ID: 0108

**User Response**

Information only; no action is required.

- **4000006d-00000000 : Management Controller [arg1]: Configuration saved to a file by user [arg2].**

A user saved a Management Controller configuration to a file.

**Severity**

Info

**Serviceable**

No

**Automatically notify support**

No

**Alert Category**

none

**SNMP Trap ID****CIM Information**

Prefix: IMM ID: 0109

**User Response**

Information only; no action is required.

- **4000006e-00000000 : Alert Configuration Global Event Notification set by user [arg1]: RetryLimit=[arg2], RetryInterval=[arg3], EntryInterval=[arg4].**

A user changed the Global Event Notification settings.

**Severity**

Info

**Serviceable**

No

**Automatically notify support**

No

**Alert Category**

none

**SNMP Trap ID****CIM Information**

Prefix: IMM ID: 0110

**User Response**

Information only; no action is required.

- **4000006f-00000000 : Alert Recipient Number [arg1] updated: Name=[arg2], DeliveryMethod=[arg3], Address=[arg4], IncludeLog=[arg5], Enabled=[arg6], EnabledAlerts=[arg7], AllowedFilters=[arg8].**

The specified user has changed or reset the remote alert recipient configuration.

**Severity**

Info

**Serviceable**

No

**Automatically notify support**

No

**Alert Category**

none

**SNMP Trap ID****CIM Information**

Prefix: IMM ID: 0111

**User Response**

Information only; no action is required.

- **40000070-00000000 : SNMP Traps enabled by user [arg1]: EnabledAlerts=[arg2], AllowedFilters=[arg3].**

The specified user has enabled Simple Network Management Protocol (SNMP) traps.

**Severity**

Info

**Serviceable**

No

**Automatically notify support**

No

**Alert Category**

none

**SNMP Trap ID**

**CIM Information**

Prefix: IMM ID: 0112

**User Response**

Information only; no action is required.

- **40000071-00000000 : The power cap value changed from [arg1] watts to [arg2] watts by user [arg3].**

The power capping level has been changed.

**Severity**

Info

**Serviceable**

No

**Automatically notify support**

No

**Alert Category**

none

**SNMP Trap ID****CIM Information**

Prefix: IMM ID: 0113

**User Response**

Information only; no action is required.

- **40000072-00000000 : The minimum power cap value changed from [arg1] watts to [arg2] watts.**

The minimum power cap value has been changed.

**Severity**

Info

**Serviceable**

No

**Automatically notify support**

No

**Alert Category**

none

**SNMP Trap ID****CIM Information**

Prefix: IMM ID: 0114

**User Response**

Information only; no action is required.

- **40000073-00000000 : The maximum power cap value changed from [arg1] watts to [arg2] watts.**

The maximum power cap value has been changed.

**Severity**

Info

**Serviceable**

No

**Automatically notify support**

No

**Alert Category**

none

**SNMP Trap ID****CIM Information**

Prefix: IMM ID: 0115

**User Response**

Information only; no action is required.

- **40000074-00000000 : The soft minimum power cap value changed from [arg1] watts to [arg2] watts.**

The soft minimum power cap value has been changed.

**Severity**

Info

**Serviceable**

No

**Automatically notify support**

No

**Alert Category**

none

**SNMP Trap ID****CIM Information**

Prefix: IMM ID: 0116

**User Response**

Information only; no action is required.

- **40000075-00000000 : The measured power value exceeded the power cap value.**

The measured power value has exceeded the power cap value.

**Severity**

Warning

**Serviceable**

No

**Automatically notify support**

No

**Alert Category**

Warning - Power

**SNMP Trap ID**

164

**CIM Information**

Prefix: IMM ID: 0117

**User Response**

- Make sure IMM firmware is at the latest level.

- Raise the system power cap value or adjust the system workload to be less than the currently applied power cap.

**Related links**

- "Updating firmware and device drivers" on page 23
- IBM Flex System and IBM PureFlex Firmware Updates Best Practices

- **40000076-00000000 : The new minimum power cap value exceeded the power cap value.**

The new minimum power cap value has exceeded the power cap value.

**Severity**

Warning

**Serviceable**

No

**Automatically notify support**

No

**Alert Category**

Warning - Power

**SNMP Trap ID**

164

**CIM Information**

Prefix: IMM ID: 0118

**User Response**

User may need to adjust the power cap value to be greater or equal to the minimum power cap.

- **40000077-00000000 : Power capping was activated by user [arg1].**

The power capping control has been enabled.

**Severity**

Info

**Serviceable**

No

**Automatically notify support**

No

**Alert Category**

none

**SNMP Trap ID**

**CIM Information**

Prefix: IMM ID: 0119

**User Response**

Information only; no action is required.

- **40000078-00000000 : Power capping was deactivated by user [arg1].**

The power capping control has been disabled.

**Severity**

Info

**Serviceable**

No

**Automatically notify support**

No

**Alert Category**

none

**SNMP Trap ID**

**CIM Information**

Prefix: IMM ID: 0120

**User Response**

Information only; no action is required.

- **40000079-00000000 : Static Power Savings mode has been turned on by user [arg1].**

Static Power Savings mode turned on by user.

**Severity**

Info

**Serviceable**

No

**Automatically notify support**

No

**Alert Category**

none

**SNMP Trap ID**

**CIM Information**

Prefix: IMM ID: 0121

**User Response**

Information only; no action is required.

- **4000007a-00000000 : Static Power Savings mode has been turned off by user [arg1].**

Static Power Savings mode turned off by user.

**Severity**

Info

**Serviceable**

No

**Automatically notify support**

No

**Alert Category**

none

**SNMP Trap ID**

**CIM Information**

Prefix: IMM ID: 0122

**User Response**

Information only; no action is required.

- **4000007b-00000000 : Dynamic Power Savings mode has been turned on by user [arg1].**

Dynamic Power Savings mode turned on by user.

**Severity**

Info

**Serviceable**

No

**Automatically notify support**

No

**Alert Category**

none

**SNMP Trap ID****CIM Information**

Prefix: IMM ID: 0123

**User Response**

Information only; no action is required.

- **4000007c-00000000 : Dynamic Power Savings mode has been turned off by user [arg1].**

Dynamic Power Savings mode turned off by user.

**Severity**

Info

**Serviceable**

No

**Automatically notify support**

No

**Alert Category**

none

**SNMP Trap ID****CIM Information**

Prefix: IMM ID: 0124

**User Response**

Information only; no action is required.

- **4000007d-00000000 : Power cap and external throttling occurred.**

Power cap and external throttling has occurred.

**Severity**

Info

**Serviceable**

No

**Automatically notify support**

No

**Alert Category**

none

**SNMP Trap ID****CIM Information**

Prefix: IMM ID: 0125



**User Response**

Information only; no action is required.

- **4000007e-00000000 : External throttling occurred .**

External throttling has occurred.

**Severity**

Info

**Serviceable**

No

**Automatically notify support**

No

**Alert Category**

none

**SNMP Trap ID****CIM Information**

Prefix: IMM ID: 0126

**User Response**

Information only; no action is required.

- **4000007f-00000000 : Power cap throttling occurred.**

Power cap throttling has occurred.

**Severity**

Info

**Serviceable**

No

**Automatically notify support**

No

**Alert Category**

none

**SNMP Trap ID****CIM Information**

Prefix: IMM ID: 0127

**User Response**

Information only; no action is required.

- **40000080-00000000 : Remote Control session started by user [arg1] in [arg2] mode.**

Remote Control session started.

**Severity**

Info

**Serviceable**

No

**Automatically notify support**

No

**Alert Category**

none

#### SNMP Trap ID

#### CIM Information

Prefix: IMM ID: 0128

#### User Response

Information only; no action is required.

- **40000081-00000000 : PXE boot requested by user [arg1].**

PXE boot requested.

#### Severity

Info

#### Serviceable

No

#### Automatically notify support

No

#### Alert Category

none

#### SNMP Trap ID

#### CIM Information

Prefix: IMM ID: 0129

#### User Response

Information only; no action is required.

- **40000082-00000000 : The measured power value has returned below the power cap value.**

The measured power value has returned below the power cap value.

#### Severity

Info

#### Serviceable

No

#### Automatically notify support

No

#### Alert Category

Warning - Power

#### SNMP Trap ID

164

#### CIM Information

Prefix: IMM ID: 0130

#### User Response

Information only; no action is required.

- **40000083-00000000 : The new minimum power cap value has returned below the power cap value.**

The new minimum power cap value has returned below the power cap value.

#### Severity

Info

**Serviceable**

No

**Automatically notify support**

No

**Alert Category**

Warning - Power

**SNMP Trap ID**

164

**CIM Information**

Prefix: IMM ID: 0131

**User Response**

Information only; no action is required.

- **40000084-00000000 : IMM firmware mismatch between nodes [arg1] and [arg2]. Please attempt to flash the IMM firmware to the same level on all nodes.**

A mismatch of IMM firmware between nodes has been detected.

**Severity**

Error

**Serviceable**

No

**Automatically notify support**

No

**Alert Category**

System - Other

**SNMP Trap ID**

22

**CIM Information**

Prefix: IMM ID: 0132

**User Response**

Attempt to update the IMM firmware to the same level on all nodes.

**Related links**

- "Updating firmware and device drivers" on page 23
- IBM Flex System and IBM PureFlex Firmware Updates Best Practices

- **40000085-00000000 : FPGA firmware mismatch between nodes [arg1] and [arg2]. Please attempt to flash the FPGA firmware to the same level on all nodes.**

A mismatch of FPGA firmware between nodes has been detected.

**Severity**

Error

**Serviceable**

No

**Automatically notify support**

No

**Alert Category**

System - Other

**SNMP Trap ID**

**CIM Information**

Prefix: IMM ID: 0133

**User Response**

Attempt to update the FPGA firmware to the same level on all nodes.

**Related links**

- "Updating firmware and device drivers" on page 23
- IBM Flex System and IBM PureFlex Firmware Updates Best Practices

- **40000086-00000000 : Test Call Home Generated by user [arg1].**

The specified user has generated a test automatic support notification.

**Severity**

Info

**Serviceable**

No

**Automatically notify support**

Yes

**Alert Category**

none

**SNMP Trap ID****CIM Information**

Prefix: IMM ID: 0134

**User Response**

Information only; no action is required.

- **40000087-00000000 : Manual Call Home by user [arg1]: [arg2].**

The specified user has submitted a service request.

**Severity**

Info

**Serviceable**

No

**Automatically notify support**

Yes

**Alert Category**

none

**SNMP Trap ID****CIM Information**

Prefix: IMM ID: 0135

**User Response**

IBM Support will address the problem.

- **40000088-00000000 : Management Controller [arg1]: Configuration restoration from a file by user [arg2] completed.**

The specified user has successfully restored the configuration of the specified management controller from a file.

**Severity**

Info

**Serviceable**

No

**Automatically notify support**

No

**Alert Category**

none

**SNMP Trap ID****CIM Information**

Prefix: IMM ID: 0136

**User Response**

Information only; no action is required.

- **40000089-00000000 : Management Controller [arg1]: Configuration restoration from a file by user [arg2] failed to complete.**

Restoration of the configuration of the specified management controller from a file by the specified user has not been completed.

**Severity**

Error

**Serviceable**

No

**Automatically notify support**

No

**Alert Category**

System - Other

**SNMP Trap ID**

22

**CIM Information**

Prefix: IMM ID: 0137

**User Response**

1. Turn off the server and disconnect it from the power source. You must disconnect the server from ac power to reset the IMM.
  2. After 45 seconds, reconnect the server to the power source and turn on the server.
  3. Retry the operation
- **4000008a-00000000 : Management Controller [arg1]: Configuration restoration from a file by user [arg2] failed to start.**

Restoration of the configuration of the specified management controller from a file by the specified user has failed to start.

**Severity**

Error

**Serviceable**

No

**Automatically notify support**

No

**Alert Category**

System - Other

**SNMP Trap ID**

22

**CIM Information**

Prefix: IMM ID: 0138

**User Response**

1. Turn off the server and disconnect it from the power source. You must disconnect the server from ac power to reset the IMM.
  2. After 45 seconds, reconnect the server to the power source and turn on the server.
  3. Retry the operation
- **4000008b-00000000 : One or more of the Storage Management IP addresses has changed.**  
One or more of the Storage Management IP addresses has changed.

**Severity**

Info

**Serviceable**

No

**Automatically notify support**

No

**Alert Category**

System - IMM Network event

**SNMP Trap ID**

37

**CIM Information**

Prefix: IMM ID: 0139

**User Response**

Information only; no action is required.

- **4000008c-00000000 : Security: Userid: [arg1] had [arg2] login failures from a CIM client at IP address [arg3].**

A user has exceeded the maximum allowed number of unsuccessful login attempts from a CIM client and has been prevented from logging in for the lockout period.

**Severity**

Warning

**Serviceable**

No

**Automatically notify support**

No

**Alert Category**

System - Remote Login

**SNMP Trap ID**

30

**CIM Information**

Prefix: IMM ID: 0140

**User Response**

Complete the following steps until the problem is solved:

1. Make sure that the correct login ID and password are being used.
  2. Have the system administrator reset the login ID or password.
- **4000008d-00000000 : Remote access attempt failed. Invalid userid or password received. Userid is [arg1] from a CIM client at IP address [arg2].**

A user has attempted to log in from a CIM client by using an invalid login ID or password.

**Severity**

Info

**Serviceable**

No

**Automatically notify support**

No

**Alert Category**

System - Remote Login

**SNMP Trap ID**

30

**CIM Information**

Prefix: IMM ID: 0141

**User Response**

Make sure that the correct login ID and password are being used.

- **4000008e-00000000 : Device [arg1] VPD is not valid.**

The VPD for a device is invalid

**Severity**

Warning

**Serviceable**

No

**Automatically notify support**

No

**Alert Category**

System - Other

**SNMP Trap ID**

22

**CIM Information**

Prefix: IMM ID: 0142

**User Response**

The device with invalid VPD data should be replaced.

- **4000008f-00000000 : The bare metal connection process has been started.**

Bare Metal Connection process has been started

**Severity**

Info

**Serviceable**

No

**Automatically notify support**

No

**Alert Category**

System - Other

**SNMP Trap ID**

22

**CIM Information**

Prefix: IMM ID: 0143

**User Response**

Information only; no action is required.

- **40000090-00000000 : The bare metal update application reports a status of [arg1].**

Bare Metal Update Application Status

**Severity**

Info

**Serviceable**

No

**Automatically notify support**

No

**Alert Category**

System - Other

**SNMP Trap ID**

22

**CIM Information**

Prefix: IMM ID: 0144

**User Response**

Information only; no action is required.

- **40000091-00000000 : User [arg1] has terminated an active console session.**

A user has terminated an active console session.

**Severity**

Info

**Serviceable**

No

**Automatically notify support**

No

**Alert Category**

none

**SNMP Trap ID**

**CIM Information**

Prefix: IMM ID: 0145

**User Response**

Information only; no action is required.



- **40000092-00000000 : TKLM servers set by user [arg1]: TKLMServer1=[arg2] Port=[arg3], TKLMServer2=[arg4] Port=[arg5], TKLMServer3=[arg6] Port=[arg7], TKLMServer4=[arg8] Port=[arg9].**

A user configured the TKLM servers.

**Severity**

Info

**Serviceable**

No

**Automatically notify support**

No

**Alert Category**

none

**SNMP Trap ID**

**CIM Information**

Prefix: IMM ID: 0146

**User Response**

Information only; no action is required.

- **40000093-00000000 : TKLM servers device group set by user [arg1]: TKLMServerDeviceGroup=[arg2] .**

A user configured the TKLM device group.

**Severity**

Info

**Serviceable**

No

**Automatically notify support**

No

**Alert Category**

none

**SNMP Trap ID**

**CIM Information**

Prefix: IMM ID: 0147

**User Response**

Information only; no action is required.

- **40000094-00000000 : User [arg1] has generated a new encryption key pair and installed a self-signed certificate for the TKLM client.**

User generated a new encryption key pair and installed a self-signed certificate for the TKLM client.

**Severity**

Info

**Serviceable**

No

**Automatically notify support**

No

**Alert Category**

none

**SNMP Trap ID****CIM Information**

Prefix: IMM ID: 0148

**User Response**

Information only; no action is required.

- **40000095-00000000 : User [arg1] has generated a new encryption key and certificate signing request for the TKLM client.**

User generated a new encryption key and certificate signing request for the TKLM client.

**Severity**

Info

**Serviceable**

No

**Automatically notify support**

No

**Alert Category**

none

**SNMP Trap ID****CIM Information**

Prefix: IMM ID: 0149

**User Response**

Information only; no action is required.

- **40000096-00000000 : User [arg1] has imported a signed certificate for the TKLM client from [arg2].**

User imported a signed certificate for the TKLM client.

**Severity**

Info

**Serviceable**

No

**Automatically notify support**

No

**Alert Category**

none

**SNMP Trap ID****CIM Information**

Prefix: IMM ID: 0150

**User Response**

Information only; no action is required.

- **40000097-00000000 : User [arg1] has imported a server certificate for the TKLM server.**

User imported a server certificate for the TKLM Server.

**Severity**

Info

**Serviceable**

No

**Automatically notify support**

No

**Alert Category**

none

**SNMP Trap ID****CIM Information**

Prefix: IMM ID: 0151

**User Response**

Information only; no action is required.

- **40000098-00000000 : The UEFI Definitions have been changed.**

UEFI Definitions change has been detected.

**Severity**

Info

**Serviceable**

No

**Automatically notify support**

No

**Alert Category**

none

**SNMP Trap ID****CIM Information**

Prefix: IMM ID: 0152

**User Response**

Information only; no action is required.

- **40000099-00000000 : Security: Userid: [arg1] had [arg2] login failures from IPMI client at IP address [arg3].**

A user was not able to log in to a Management Controller from IPMI

**Severity**

Info

**Serviceable**

No

**Automatically notify support**

No

**Alert Category**

System - Remote Login

**SNMP Trap ID**

30

**CIM Information**

**Prefix: IMM ID: 0153**

**User Response**

Information only; no action is required.

- **4000009a-00000000 : Security: Userid: [arg1] had [arg2] login failures from SNMP client at IP address [arg3].**

A user was not able to access a Management Controller from SNMP.

**Severity**

Info

**Serviceable**

No

**Automatically notify support**

No

**Alert Category**

System - Remote Login

**SNMP Trap ID**

30

**CIM Information**

**Prefix: IMM ID: 0154**

**User Response**

Information only; no action is required.

- **4000009b-00000000 : Security: Userid: [arg1] had [arg2] login failures from IPMI serial client.**

A user was not able to log in to a Management Controller from an IPMI serial client.

**Severity**

Info

**Serviceable**

No

**Automatically notify support**

No

**Alert Category**

System - Remote Login

**SNMP Trap ID**

30

**CIM Information**

**Prefix: IMM ID: 0155**

**User Response**

Information only; no action is required.

- **4000009c-00000000 : Remote Login Successful. Login ID: [arg1] from [arg2] serial interface.**

A user successfully logged in to a Management Controller.

**Severity**

Info

**Serviceable**

No

**Automatically notify support**

No

**Alert Category**

System - Remote Login

**SNMP Trap ID**

30

**CIM Information**

Prefix: IMM ID: 0156

**User Response**

Information only; no action is required.

- **4000009d-00000000 : Login ID: [arg1] from [arg2] at IP address [arg3] has logged off.**

A user logged off of a Management Controller.

**Severity**

Info

**Serviceable**

No

**Automatically notify support**

No

**Alert Category**

System - Remote Login

**SNMP Trap ID**

30

**CIM Information**

Prefix: IMM ID: 0157

**User Response**

Information only; no action is required.

- **4000009e-00000000 : Login ID: [arg1] from [arg2] at IP address [arg3] has been logged off.**

A user has been logged off of a Management Controller.

**Severity**

Info

**Serviceable**

No

**Automatically notify support**

No

**Alert Category**

System - Remote Login

**SNMP Trap ID**

30

**CIM Information**

Prefix: IMM ID: 0158

**User Response**

Information only; no action is required.

- **4000009f-00000000 : User [arg1] has initiated a TKLM Server Connection Test to check connectivity to server [arg2].**

User initiated a TKLM Server Connection test.

**Severity**

Info

**Serviceable**

No

**Automatically notify support**

No

**Alert Category**

none

**SNMP Trap ID****CIM Information**

Prefix: IMM ID: 0159

**User Response**

Information only; no action is required.

- **400000a0-00000000 : User [arg1] has initiated an SMTP Server Connection Test.**

User initiated an SMTP Server Connection test.

**Severity**

Info

**Serviceable**

No

**Automatically notify support**

No

**Alert Category**

none

**SNMP Trap ID****CIM Information**

Prefix: IMM ID: 0160

**User Response**

Information only; no action is required.

- **400000a1-00000000 : UEFI Reported: [arg1].**

UEFI audit event logged.

**Severity**

Info

**Serviceable**

No

**Automatically notify support**

No

**Alert Category**

none

**SNMP Trap ID****CIM Information**

Prefix: IMM ID: 0161

**User Response**

Information only; no action is required.

- **400000a2-00000000 : User [arg1] has [arg2] file [arg3] from [arg4].**

User has mounted/unmounted file from URL or server.

**Severity**

Info

**Serviceable**

No

**Automatically notify support**

No

**Alert Category**

System - Other

**SNMP Trap ID**

22

**CIM Information**

Prefix: IMM ID: 0162

**User Response**

Information only; no action is required.

- **400000a3-00000000 : User [arg1] has set the SMTP Server reverse-path to [arg2].**

User set SMTP Server reverse-path address.

**Severity**

Info

**Serviceable**

No

**Automatically notify support**

No

**Alert Category**

System - Other

**SNMP Trap ID**

22

**CIM Information**

Prefix: IMM ID: 0163

**User Response**

Information only; no action is required.

- **400000a4-00000000 : User [arg1] has removed a certificate.**

User removed certificate.

**Severity**

Info

**Serviceable**

No

**Automatically notify support**

No

**Alert Category**

System - Other

**SNMP Trap ID**

22

**CIM Information**

Prefix: IMM ID: 0164

**User Response**

Information only; no action is required.

- **400000a5-00000000 : A certificate has been revoked .**

A certificate has been revoked.

**Severity**

Info

**Serviceable**

No

**Automatically notify support**

No

**Alert Category**

System - Other

**SNMP Trap ID**

22

**CIM Information**

Prefix: IMM ID: 0165

**User Response**

Install a new certificate.

- **400000a6-00000000 : The server was restarted for an unknown reason.**

The server was restarted for an unknown reason.

**Severity**

Info

**Serviceable**

No

**Automatically notify support**

No

**Alert Category**

System - Other

**SNMP Trap ID**

22

**CIM Information**

Prefix: IMM ID: 0166

**User Response**

Information only; no action is required.

- **400000a7-00000000 : The server is restarted by chassis control command.**

Server is restarted by chassis control command.

**Severity**

Info



**Serviceable**

No

**Automatically notify support**

No

**Alert Category**

System - Other

**SNMP Trap ID**

22

**CIM Information**

Prefix: IMM ID: 0167

**User Response**

Information only; no action is required.

- **400000a8-00000000 : The server was reset via pushbutton.**

Server was reset via pushbutton.

**Severity**

Info

**Serviceable**

No

**Automatically notify support**

No

**Alert Category**

System - Other

**SNMP Trap ID**

22

**CIM Information**

Prefix: IMM ID: 0168

**User Response**

Information only; no action is required.

- **400000a9-00000000 : The server was powered-up via power pushbutton.**

Server was powered-up via power pushbutton.

**Severity**

Info

**Serviceable**

No

**Automatically notify support**

No

**Alert Category**

System - Other

**SNMP Trap ID**

22

**CIM Information**

Prefix: IMM ID: 0169

**User Response**

Information only; no action is required.

- **400000aa-00000000 : The server was restarted when the watchdog expired..**

Server was restarted when the watchdog expired.

**Severity**

Info

**Serviceable**

No

**Automatically notify support**

No

**Alert Category**

System - Other

**SNMP Trap ID**

22

**CIM Information**

Prefix: IMM ID: 0170

**User Response**

Information only; no action is required.

- **400000ab-00000000 : The server was restarted for OEM reason.**

Server was restarted for OEM reason.

**Severity**

Info

**Serviceable**

No

**Automatically notify support**

No

**Alert Category**

System - Other

**SNMP Trap ID**

22

**CIM Information**

Prefix: IMM ID: 0171

**User Response**

Information only; no action is required.

- **400000ac-00000000 : The server was automatically powered on because the power restore policy is set to always restore..**

Server was automatically powered on because the power restore policy is set to always restore.

**Severity**

Info

**Serviceable**

No

**Automatically notify support**

No

**Alert Category**

System - Other

**SNMP Trap ID**

22

**CIM Information****Prefix: IMM ID: 0172****User Response**

Information only; no action is required.

- **40000ad-00000000 : The server was automatically powered on because the power restore policy is set to restore previous power state..**

Server was automatically powered on because the power restore policy is set to restore previous power state.

**Severity**

Info

**Serviceable**

No

**Automatically notify support**

No

**Alert Category**

System - Other

**SNMP Trap ID**

22

**CIM Information****Prefix: IMM ID: 0173****User Response**

Information only; no action is required.

- **40000ae-00000000 : The server was reset via Platform Event Filter.**

Server was reset via Platform Event Filter.

**Severity**

Info

**Serviceable**

No

**Automatically notify support**

No

**Alert Category**

System - Other

**SNMP Trap ID**

22

**CIM Information****Prefix: IMM ID: 0174****User Response**

Information only; no action is required.

- **40000af-00000000 : The server was power-cycled via Platform Event Filter.**

Server was power-cycled via Platform Event Filter.

**Severity**

Info

**Serviceable**

No

**Automatically notify support**

No

**Alert Category**

System - Other

**SNMP Trap ID**

22

**CIM Information**

Prefix: IMM ID: 0175

**User Response**

Information only; no action is required.

- **400000b0-00000000 : The server was soft reset.**

Server was soft reset.

**Severity**

Info

**Serviceable**

No

**Automatically notify support**

No

**Alert Category**

System - Other

**SNMP Trap ID**

22

**CIM Information**

Prefix: IMM ID: 0176

**User Response**

Information only; no action is required.

- **400000b1-00000000 : The server was powered up via Real Time Clock (scheduled power on).**

Server was powered up via Real Time Clock (scheduled power on).

**Severity**

Info

**Serviceable**

No

**Automatically notify support**

No

**Alert Category**

System - Other

**SNMP Trap ID**

22

**CIM Information**

Prefix: IMM ID: 0177

**User Response**

Information only; no action is required.

- **400000b2-00000000 : The server was powered off for an unknown reason.**

Server was powered off for an unknown reason.

**Severity**

Info

**Serviceable**

No

**Automatically notify support**

No

**Alert Category**

System - Other

**SNMP Trap ID**

22

**CIM Information**

Prefix: IMM ID: 0178

**User Response**

Information only; no action is required.

- **400000b3-00000000 : The server was powered off by chassis control command.**

Server was powered off by chassis control command.

**Severity**

Info

**Serviceable**

No

**Automatically notify support**

No

**Alert Category**

System - Other

**SNMP Trap ID**

22

**CIM Information**

Prefix: IMM ID: 0179

**User Response**

Information only; no action is required.

- **400000b4-00000000 : The server was powered off via pushbutton.**

Server was powered off via pushbutton.

**Severity**

Info

**Serviceable**

No

**Automatically notify support**

No

**Alert Category**

System - Other

**SNMP Trap ID**

**CIM Information**

Prefix: IMM ID: 0180

**User Response**

Information only; no action is required.

- **400000b5-00000000 : The server was powered off when the watchdog expired.**

Server was powered off when the watchdog expired.

**Severity**

Info

**Serviceable**

No

**Automatically notify support**

No

**Alert Category**

System - Other

**SNMP Trap ID**

22

**CIM Information**

Prefix: IMM ID: 0181

**User Response**

Information only; no action is required.

- **400000b6-00000000 : The server stayed powered off because the power restore policy is set to always restore..**

Server stayed powered off because the power restore policy is set to always restore.

**Severity**

Info

**Serviceable**

No

**Automatically notify support**

No

**Alert Category**

System - Other

**SNMP Trap ID**

22

**CIM Information**

Prefix: IMM ID: 0182

**User Response**

Information only; no action is required.

- **400000b7-00000000 : The server stayed powered off because the power restore policy is set to restore previous power state..**

Server stayed powered off because the power restore policy is set to restore previous power state.

**Severity**

Info

**Serviceable**

No

**Automatically notify support**

No

**Alert Category**

System - Other

**SNMP Trap ID**

22

**CIM Information**

Prefix: IMM ID: 0183

**User Response**

Information only; no action is required.

- **400000b8-00000000 : The server was powered off via Platform Event Filter.**

Server was power off via Platform Event Filter.

**Severity**

Info

**Serviceable**

No

**Automatically notify support**

No

**Alert Category**

System - Other

**SNMP Trap ID**

22

**CIM Information**

Prefix: IMM ID: 0184

**User Response**

Information only; no action is required.

- **400000b9-00000000 : The server was powered off via Real Time Clock (scheduled power off).**

Server was powered up via Real Time Clock (scheduled power off).

**Severity**

Info

**Serviceable**

No

**Automatically notify support**

No

**Alert Category**

System - Other

**SNMP Trap ID**

22

**CIM Information**

Prefix: IMM ID: 0185

**User Response**

Information only; no action is required.

- **400000ba-00000000 : Management Controller [arg1] reset was initiated due to Power-On-Reset.**  
Management Controller reset was initiated due to Power-On-Reset.

**Severity**

Info

**Serviceable**

No

**Automatically notify support**

No

**Alert Category**

System - Other

**SNMP Trap ID**

22

**CIM Information**

Prefix: IMM ID: 0186

**User Response**

Information only; no action is required.

- **400000bb-00000000 : Management Controller [arg1] reset was initiated by PRESET.**  
Management Controller reset was initiated by PRESET.

**Severity**

Info

**Serviceable**

No

**Automatically notify support**

No

**Alert Category**

System - Other

**SNMP Trap ID**

22

**CIM Information**

Prefix: IMM ID: 0187

**User Response**

Information only; no action is required.

- **400000bc-00000000 : Management Controller [arg1] reset was initiated by CMM.**  
Management Controller reset was initiated by CMM.

**Severity**

Info

**Serviceable**

No

**Automatically notify support**

No

**Alert Category**

System - Other

**SNMP Trap ID**



22

**CIM Information**

Prefix: IMM ID: 0188

**User Response**

Information only; no action is required.

- **400000bd-00000000 : Management Controller [arg1] reset was initiated by IMM firmware.**

Management Controller reset was initiated by IMM firmware.

**Severity**

Info

**Serviceable**

No

**Automatically notify support**

No

**Alert Category**

System - Other

**SNMP Trap ID**

22

**CIM Information**

Prefix: IMM ID: 0189

**User Response**

Information only; no action is required.

- **400000be-00000000 : The [arg1] certificate is expired and has been removed.**

Expired certificate has been removed.

**Severity**

Info

**Serviceable**

No

**Automatically notify support**

No

**Alert Category**

System - Other

**SNMP Trap ID**

22

**CIM Information**

Prefix: IMM ID: 0190

**User Response**

Install a new certificate.

- **400000bf-00000000 : Operating System status has changed to [arg1].**

Operating System status change.

**Severity**

Info

**Serviceable**

No

**Automatically notify support**

No

**Alert Category**

System - Other

**SNMP Trap ID**

22

**CIM Information**

Prefix: IMM ID: 0191

**User Response**

Information only; no action is required.

- **400000c0-00000000 : Inventory data collecting and processing complete for [arg1].**

Inventory data collecting and processing complete.

**Severity**

Info

**Serviceable**

No

**Automatically notify support**

No

**Alert Category**

System - Other

**SNMP Trap ID**

22

**CIM Information**

Prefix: IMM ID: 0192

**User Response**

Information only; no action is required.

- **80010202-0701ffff : Numeric sensor [NumericSensorElementName] going low (lower critical) has asserted.**

A voltage has dropped below its specified threshold.

**Severity**

Error

**Serviceable**

Yes

**Automatically notify support**

Yes

**Alert Category**

Critical - Voltage

**SNMP Trap ID**

1

**CIM Information**

Prefix: PLAT ID: 0480

**User Response**

Use one of the following procedures:

- If the specified sensor is SysBrd 3.3V or SysBrd 5V, replace the system board.

- If the specified sensor is SysBrd 12V, check the Chassis Management Module or Flex System Manager event log for power-supply-related issues, and resolve those issues. If the problem remains, replace the system board.

- **80010202-2801ffff : Sensor Planar VBAT has detected low battery voltage.**

The CMOS battery voltage has dropped below its specified threshold.

**Severity**

Error

**Serviceable**

Yes

**Automatically notify support**

No

**Alert Category**

Critical - Voltage

**SNMP Trap ID**

1

**CIM Information**

Prefix: PLAT ID: 0480

**User Response**

Replace the CMOS battery.

- **80010701-3701ffff : Numeric sensor [NumericSensorElementName] going high (upper non-critical) has asserted.**

The inlet 1 temperature has exceeded its specified threshold.

**Severity**

Warning

**Serviceable**

Yes

**Automatically notify support**

No

**Alert Category**

Warning - Temperature

**SNMP Trap ID**

12

**CIM Information**

Prefix: PLAT ID: 0490

**User Response**

Complete the following steps until the problem is solved:

1. Check the Chassis Management Module or Flex System Manager event log for any fan- or cooling-related issues.
2. Make sure that the airflow at the front and rear of the chassis is not obstructed and that fillers are in place and correctly installed.
3. Make sure that the room temperature is within operating specifications.

- **80010701-3702ffff : Numeric sensor [NumericSensorElementName] going high (upper non-critical) has asserted.**

The inlet 2 temperature has exceeded its specified threshold.

**Severity**

Warning

**Serviceable**

Yes

**Automatically notify support**

No

**Alert Category**

Warning - Temperature

**SNMP Trap ID**

12

**CIM Information**

**Prefix:** PLAT ID: 0490

**User Response**

Complete the following steps until the problem is solved:

1. Check the Chassis Management Module or Flex System Manager event log for any fan- or cooling-related issues.
  2. Make sure that the airflow at the front and rear of the chassis is not obstructed and that fillers are in place and correctly installed.
  3. Make sure that the room temperature is within operating specifications.
- **80010901-3701ffff : Numeric sensor [NumericSensorElementName] going high (upper critical) has asserted.**

The inlet 1 temperature has exceeded its specified threshold. The compute node has attempted a soft shutdown.

**Severity**

Error

**Serviceable**

Yes

**Automatically notify support**

No

**Alert Category**

Critical - Temperature

**SNMP Trap ID**

0

**CIM Information**

**Prefix:** PLAT ID: 0494

**User Response**

Complete the following steps until the problem is solved:

1. Check the Chassis Management Module or Flex System Manager event log for any fan- or cooling-related issues.
  2. Make sure that the airflow at the front and rear of the chassis is not obstructed and that fillers are in place and correctly installed.
  3. Make sure that the room temperature is within operating specifications.
- **80010901-3702ffff : Numeric sensor [NumericSensorElementName] going high (upper critical) has asserted.**

The inlet 2 temperature has exceeded its specified threshold. The compute node has attempted a soft shutdown.

**Severity**

Error

**Serviceable**

Yes

**Automatically notify support**

No

**Alert Category**

Critical - Temperature

**SNMP Trap ID**

0

**CIM Information**

**Prefix: PLAT ID:** 0494

**User Response**

Complete the following steps until the problem is solved:

1. Check the Chassis Management Module or Flex System Manager event log for any fan- or cooling-related issues.
  2. Make sure that the airflow at the front and rear of the chassis is not obstructed and that fillers are in place and correctly installed.
  3. Make sure that the room temperature is within operating specifications.
- **80010902-0701ffff : Sensor [NumericSensorElementName] has detected high voltage.**  
A voltage has exceeded its specified threshold.

**Severity**

Error

**Serviceable**

Yes

**Automatically notify support**

Yes

**Alert Category**

Critical - Voltage

**SNMP Trap ID**

1

**CIM Information**

**Prefix: PLAT ID:** 0494

**User Response**

Use one of the following procedures:

- If the specified sensor is Planar 3.3V or Planar 5V, replace the system board.
  - If the specified sensor is Planar 12V, check the Chassis Management Module or Flex System Manager event log for power-supply-related issues, and resolve those issues. If the problem remains, replace the system board.
- **80010b01-3701ffff : Numeric sensor Inlet 1 Temp going high (upper non-recoverable) has asserted. has asserted.**  
The inlet temperature has exceeded its specified threshold. The compute node has initiated a hard shutdown.

**Severity**

Error

**Serviceable**

Yes

**Automatically notify support**

No

**Alert Category**

Critical - Temperature

**SNMP Trap ID**

0

**CIM Information****Prefix: PLAT ID:** 0498**User Response**

Complete the following steps until the problem is solved:

1. Check the Chassis Management Module or Flex System Manager event log for any fan- or cooling-related issues.
  2. Make sure that the airflow at the front and rear of the chassis is not obstructed and that fillers are in place and correctly installed.
  3. Make sure that the room temperature is within operating specifications.
- **80010b01-3702ffff : Numeric sensor Inlet 2 Temp going high (upper non-recoverable) has asserted.**  
The inlet temperature has risen above the specified threshold. The system has initiated a hard shutdown.

**Severity**

Error

**Serviceable**

Yes

**Automatically notify support**

No

**Alert Category**

Critical - Temperature

**SNMP Trap ID**

0

**CIM Information****Prefix: PLAT ID:** 0498**User Response**

Complete the following steps:

1. Check the CMM or FSM event log for any fan or cooling related issues.
  2. Make sure that the airflow at the front and rear of the chassis is not obstructed and that fillers are in place and correctly installed.
  3. Make sure that the room temperature is within operating specifications.
- **80030006-2101ffff : Sensor Sig Verify Fail has deasserted.**  
The secure UEFI update has been completed.

**Severity**

Info

**Serviceable**

No

**Automatically notify support**

No

**Alert Category**

System - Other

**SNMP Trap ID****CIM Information**

Prefix: PLAT ID: 0509

**User Response**

Information only; no action is required.

- **8003010e-2581ffff : Sensor Memory Resized has asserted.**

A sensor has detected.

**Severity**

Info

**Serviceable**

No

**Automatically notify support**

No

**Alert Category**

System - Other

**SNMP Trap ID****CIM Information**

Prefix: PLAT ID: 0508

**User Response**

This is a UEFI detected event. The UEFI diagnostic code for this event can be found in the logged IMM message text. Please refer to the UEFI diagnostic code in the "UEFI diagnostic code" section of the Information Center for the appropriate user response.

**Related links**

– “Finding the UEFI diagnostic code” on page 776

- **8003010f-2101ffff : Sensor [SensorElementName] has asserted.**

IMM Firmware is corrupted.

**Severity**

Info

**Serviceable**

No

**Automatically notify support**

No

**Alert Category**

System - Other

**SNMP Trap ID**

**CIM Information**

Prefix: PLAT ID: 0508

**User Response**

Check the primary build level and update primary build to latest level.

- **80030112-0601ffff : Sensor [SensorElementName] has asserted.**

IMM has entered a system maintenance mode (SMM Mode, SMM Monitor) where the current power state is important.

**Severity**

Info

**Serviceable**

No

**Automatically notify support**

No

**Alert Category**

System - Other

**SNMP Trap ID****CIM Information**

Prefix: PLAT ID: 0508

**User Response**

Do not change system power state at this time unless directed to do so by the maintenance action.  
[like firmware flashing]

- **8007000d-0b01ffff : Sensor [SensorElementName] has transitioned to normal state.**

RAID volume 1 is functioning normally

**Severity**

Info

**Serviceable**

No

**Automatically notify support**

No

**Alert Category**

Warning - Other

**SNMP Trap ID**

60

**CIM Information**

Prefix: PLAT ID: 0518

**User Response**

Information Only; no action required.

- **80070101-030101ff : Sensor CPU 1 Overtemp has transitioned from normal to non-critical state.**

The microprocessor 1 temperature has risen above its specified threshold.

**Severity**

Warning

**Serviceable**

Yes



**Automatically notify support**

No

**Alert Category**

Warning - Temperature

**SNMP Trap ID**

12

**CIM Information**

**Prefix:** PLAT ID: 0520

**User Response**

Complete the following steps until the problem is solved:

1. Check the Chassis Management Module or Flex System Manager event log for any fan- or cooling-related issues.
  2. Make sure that the airflow at the front and rear of the chassis is not obstructed and that fillers are in place and correctly installed.
  3. Make sure that the room temperature is within operating specifications.
- **80070101-030102ff : Sensor CPU 1 Overtemp has transitioned from normal to non-critical state.**  
The microprocessor 1 temperature has risen above its specified threshold.

**Severity**

Warning

**Serviceable**

Yes

**Automatically notify support**

No

**Alert Category**

Warning - Temperature

**SNMP Trap ID**

12

**CIM Information**

**Prefix:** PLAT ID: 0520

**User Response**

Complete the following steps until the problem is solved:

1. Check the Chassis Management Module or Flex System Manager event log for any fan- or cooling-related issues.
  2. Make sure that the airflow at the front and rear of the chassis is not obstructed and that fillers are in place and correctly installed.
  3. Make sure that the room temperature is within operating specifications.
- **80070101-0301ffff : Sensor CPU 1 Overtemp has transitioned from normal to non-critical state.**  
The microprocessor 1 temperature has risen above its specified threshold.

**Severity**

Warning

**Serviceable**

Yes

**Automatically notify support**

No

**Alert Category**

Warning - Temperature

**SNMP Trap ID**

12

**CIM Information**

Prefix: PLAT ID: 0520

**User Response**

Complete the following steps until the problem is solved:

1. Check the Chassis Management Module or Flex System Manager event log for any fan- or cooling-related issues.
  2. Make sure that the airflow at the front and rear of the chassis is not obstructed and that fillers are in place and correctly installed.
  3. Make sure that the room temperature is within operating specifications.
- **80070101-030201ff : Sensor CPU 2 Overtemp has transitioned from normal to non-critical state.**  
The temperature of microprocessor 2 has exceeded its specified threshold.

**Severity**

Warning

**Serviceable**

Yes

**Automatically notify support**

No

**Alert Category**

Warning - Temperature

**SNMP Trap ID**

12

**CIM Information**

Prefix: PLAT ID: 0520

**User Response**

Complete the following steps until the problem is solved:

1. Check the Chassis Management Module or Flex System Manager event log for any fan- or cooling-related issues.
  2. Make sure that the airflow at the front and rear of the chassis is not obstructed and that fillers are in place and correctly installed.
  3. Make sure that the room temperature is within operating specifications.
- **80070101-030202ff : Sensor CPU 2 Overtemp has transitioned from normal to non-critical state.**  
The temperature of microprocessor 2 has exceeded its specified threshold.

**Severity**

Warning

**Serviceable**

Yes

**Automatically notify support**

No

**Alert Category**

Warning - Temperature

**SNMP Trap ID**

12

**CIM Information****Prefix:** PLAT ID: 0520**User Response**

Complete the following steps until the problem is solved:

1. Check the Chassis Management Module or Flex System Manager event log for any fan- or cooling-related issues.
  2. Make sure that the airflow at the front and rear of the chassis is not obstructed and that fillers are in place and correctly installed.
  3. Make sure that the room temperature is within operating specifications.
- **80070101-0302ffff : Sensor CPU 2 Overtemp has transitioned from normal to non-critical state.**  
The temperature of microprocessor 2 has exceeded its specified threshold.

**Severity**

Warning

**Serviceable**

Yes

**Automatically notify support**

No

**Alert Category**

Warning - Temperature

**SNMP Trap ID**

12

**CIM Information****Prefix:** PLAT ID: 0520**User Response**

Complete the following steps until the problem is solved:

1. Check the Chassis Management Module or Flex System Manager event log for any fan- or cooling-related issues.
  2. Make sure that the airflow at the front and rear of the chassis is not obstructed and that fillers are in place and correctly installed.
  3. Make sure that the room temperature is within operating specifications.
- **80070101-030301ff : Sensor CPU 3 Overtemp transitioned from normal to non-critical state.**  
The temperature of microprocessor 3 has exceeded its specified threshold.

**Severity**

Warning

**Serviceable**

Yes

**Automatically notify support**

No

**Alert Category**

Warning - Temperature

**SNMP Trap ID**

12

**CIM Information**

Prefix: PLAT ID: 0520

**User Response**

Complete the following steps until the problem is solved:

1. Check the Chassis Management Module or Flex System Manager event log for any fan- or cooling-related issues.
  2. Make sure that the airflow at the front and rear of the chassis is not obstructed and that fillers are in place and correctly installed.
  3. Make sure that the room temperature is within operating specifications.
- **80070101-030302ff : Sensor CPU 3 Overtemp transitioned from normal to non-critical state.**  
The temperature of microprocessor 3 has exceeded its specified threshold.

**Severity**

Warning

**Serviceable**

Yes

**Automatically notify support**

No

**Alert Category**

Warning - Temperature

**SNMP Trap ID**

12

**CIM Information**

Prefix: PLAT ID: 0520

**User Response**

Complete the following steps until the problem is solved:

1. Check the Chassis Management Module or Flex System Manager event log for any fan- or cooling-related issues.
  2. Make sure that the airflow at the front and rear of the chassis is not obstructed and that fillers are in place and correctly installed.
  3. Make sure that the room temperature is within operating specifications.
- **80070101-0303ffff : Sensor CPU 3 Overtemp transitioned from normal to non-critical state.**  
The temperature of microprocessor 3 has exceeded its specified threshold.

**Severity**

Warning

**Serviceable**

Yes

**Automatically notify support**

No

**Alert Category**

Warning - Temperature

**SNMP Trap ID**

12

**CIM Information**

Prefix: PLAT ID: 0520

**User Response**

Complete the following steps until the problem is solved:

1. Check the Chassis Management Module or Flex System Manager event log for any fan- or cooling-related issues.
  2. Make sure that the airflow at the front and rear of the chassis is not obstructed and that fillers are in place and correctly installed.
  3. Make sure that the room temperature is within operating specifications.
- **80070101-030401ff : Sensor CPU 4 Overtemp has transitioned from normal to non-critical state.**  
The temperature of microprocessor 4 has exceeded its specified threshold.

**Severity**

Warning

**Serviceable**

Yes

**Automatically notify support**

No

**Alert Category**

Warning - Temperature

**SNMP Trap ID**

12

**CIM Information**

Prefix: PLAT ID: 0520

**User Response**

Complete the following steps until the problem is solved:

1. Check the Chassis Management Module or Flex System Manager event log for any fan- or cooling-related issues.
  2. Make sure that the airflow at the front and rear of the chassis is not obstructed and that fillers are in place and correctly installed.
  3. Make sure that the room temperature is within operating specifications.
- **80070101-030402ff : Sensor CPU 4 Overtemp has transitioned from normal to non-critical state.**  
The temperature of microprocessor 4 has exceeded its specified threshold.

**Severity**

Warning

**Serviceable**

Yes

**Automatically notify support**

No

**Alert Category**

Warning - Temperature

**SNMP Trap ID**

12

**CIM Information**

Prefix: PLAT ID: 0520

**User Response**

Complete the following steps until the problem is solved:

1. Check the Chassis Management Module or Flex System Manager event log for any fan- or cooling-related issues.
  2. Make sure that the airflow at the front and rear of the chassis is not obstructed and that fillers are in place and correctly installed.
  3. Make sure that the room temperature is within operating specifications.
- **80070101-0304ffff : Sensor CPU 4 Overtemp has transitioned from normal to non-critical state.**

The temperature of microprocessor 4 has exceeded its specified threshold.

**Severity**

Warning

**Serviceable**

Yes

**Automatically notify support**

No

**Alert Category**

Warning - Temperature

**SNMP Trap ID**

12

**CIM Information**

**Prefix:** PLAT ID: 0520

**User Response**

Complete the following steps until the problem is solved:

1. Check the Chassis Management Module or Flex System Manager event log for any fan- or cooling-related issues.
  2. Make sure that the airflow at the front and rear of the chassis is not obstructed and that fillers are in place and correctly installed.
  3. Make sure that the room temperature is within operating specifications.
- **80070101-2c01ffff : Sensor Mezz Exp 1 temp has transitioned from normal to non-critical state.**

The temperature of the I/O expansion adapter in I/O expansion connector 1 has exceeded its specified threshold.

**Severity**

Warning

**Serviceable**

Yes

**Automatically notify support**

No

**Alert Category**

Warning - Temperature

**SNMP Trap ID**

12

**CIM Information**

**Prefix:** PLAT ID: 0520

**User Response**

Complete the following steps until the problem is solved:

1. Check the Chassis Management Module or Flex System Manager event log for any fan- or cooling-related issues.
  2. Make sure that the airflow at the front and rear of the chassis is not obstructed and that fillers are in place and correctly installed.
  3. Make sure that the room temperature is within operating specifications.
- **80070101-2c02ffff : Sensor Mezz Exp 2 temp has transitioned from normal to non-critical state.**

The temperature of the I/O expansion adapter in I/O expansion connector 2 has exceeded its specified threshold.

**Severity**

Warning

**Serviceable**

Yes

**Automatically notify support**

No

**Alert Category**

Warning - Temperature

**SNMP Trap ID**

12

**CIM Information**

**Prefix: PLAT ID:** 0520

**User Response**

Complete the following steps until the problem is solved:

1. Check the Chassis Management Module or Flex System Manager event log for any fan- or cooling-related issues.
  2. Make sure that the airflow at the front and rear of the chassis is not obstructed and that fillers are in place and correctly installed.
  3. Make sure that the room temperature is within operating specifications.
- **80070101-2c03ffff : Sensor Mezz Exp 3 temp has transitioned from normal to non-critical state.**

The temperature of the I/O expansion adapter in I/O expansion connector 3 has exceeded its specified threshold.

**Severity**

Warning

**Serviceable**

Yes

**Automatically notify support**

No

**Alert Category**

Warning - Temperature

**SNMP Trap ID**

12

**CIM Information**

**Prefix: PLAT ID:** 0520

**User Response**

Complete the following steps until the problem is solved:

1. Check the Chassis Management Module or Flex System Manager event log for any fan- or cooling-related issues.
  2. Make sure that the airflow at the front and rear of the chassis is not obstructed and that fillers are in place and correctly installed.
  3. Make sure that the room temperature is within operating specifications.
- **80070101-2c0402ff : Sensor Mezz Exp 4 temp has transitioned from normal to non-critical state.**

The temperature of the I/O expansion adapter in I/O expansion connector 4 has exceeded its specified threshold.

**Severity**

Warning

**Serviceable**

Yes

**Automatically notify support**

No

**Alert Category**

Warning - Temperature

**SNMP Trap ID**

12

**CIM Information**

**Prefix: PLAT ID:** 0520

**User Response**

Complete the following steps until the problem is solved:

1. Check the Chassis Management Module or Flex System Manager event log for any fan- or cooling-related issues.
  2. Make sure that the airflow at the front and rear of the chassis is not obstructed and that fillers are in place and correctly installed.
  3. Make sure that the room temperature is within operating specifications.
- **80070101-2c04ffff : Sensor Mezz Exp 4 temp has transitioned from normal to non-critical state.**

The temperature of the I/O expansion adapter in I/O expansion connector 4 has exceeded its specified threshold.

**Severity**

Warning

**Serviceable**

Yes

**Automatically notify support**

No

**Alert Category**

Warning - Temperature

**SNMP Trap ID**

12

**CIM Information**

**Prefix: PLAT ID:** 0520

**User Response**

Complete the following steps until the problem is solved:



1. Check the Chassis Management Module or Flex System Manager event log for any fan- or cooling-related issues.
  2. Make sure that the airflow at the front and rear of the chassis is not obstructed and that fillers are in place and correctly installed.
  3. Make sure that the room temperature is within operating specifications.
- **80070101-2d01ffff : Sensor PCH Overtemp has transitioned from normal to non-critical state.**

The temperature of the Platform Controller Hub (PCH) has exceeded its specified threshold.

**Severity**

Warning

**Serviceable**

Yes

**Automatically notify support**

No

**Alert Category**

Warning - Temperature

**SNMP Trap ID**

12

**CIM Information**

**Prefix:** PLAT ID: 0520

**User Response**

Complete the following steps until the problem is solved:

1. Check the Chassis Management Module or Flex System Manager event log for any fan- or cooling-related issues.
  2. Make sure that the airflow at the front and rear of the chassis is not obstructed and that fillers are in place and correctly installed.
  3. Make sure that the room temperature is within operating specifications.
- **8007010d-0b01ffff : Sensor [SensorElementName] has transitioned from normal to non-critical state.**

A drive failed causing RAID redundancy to be degraded.

**Severity**

Warning

**Serviceable**

Yes

**Automatically notify support**

No

**Alert Category**

Warning - Other

**SNMP Trap ID**

60

**CIM Information**

**Prefix:** PLAT ID: 0520

**User Response**

Check the physical drive and replace the bad one.

- **8007010f-2201ffff : Sensor [SensorElementName] has transitioned from normal to non-critical state.**

The GPT (GUID Partition Table) in the disk LUN (Logical Unit Number) is corrupt and may make the data in the LUN inaccessible to the system and prevent boot.

**Severity**

Warning

**Serviceable**

Yes

**Automatically notify support**

No

**Alert Category**

Warning - Other

**SNMP Trap ID**

60

**CIM Information**

**Prefix:** PLAT ID: 0520

**User Response**

Complete the following steps:

1. Check the IBM support site for service bulletins or firmware updates that apply to this GPT error.
2. Set the UEFI setting "DISK GPT Recovery" to "Automatic".
3. Replace the corrupt disk.

GPT Status : Sec Rollback Err : Secure Boot Err :

- **8007010f-2582ffff : Sensor [SensorElementName] has transitioned from normal to non-critical state.**

Less than optimal I/O resource configuration.

**Severity**

Warning

**Serviceable**

Yes

**Automatically notify support**

No

**Alert Category**

Warning - Other

**SNMP Trap ID**

60

**CIM Information**

**Prefix:** PLAT ID: 0520

**User Response**

This is a UEFI detected event. The UEFI diagnostic code for this event can be found in the logged IMM message text. Please refer to the UEFI diagnostic code in the "UEFI diagnostic code" section of the Information Center for the appropriate user response.

**Related links**

- "Finding the UEFI diagnostic code" on page 776

- **80070114-2201ffff : Sensor [SensorElementName] has transitioned from normal to non-critical state.**

One of the following sensors has indicated an abnormal condition: TPM Lock, TPM Phy Pres Set. Sensor transitioned to non-critical from normal.

**Severity**

Warning

**Serviceable**

Yes

**Automatically notify support**

No

**Alert Category**

Warning - Other

**SNMP Trap ID**

60

**CIM Information**

**Prefix:** PLAT ID: 0520

**User Response**

This is a UEFI detected event. The UEFI diagnostic code for this event can be found in the logged IMM message text. Please refer to the UEFI diagnostic code in the "UEFI diagnostic code" section of the Information Center for the appropriate user response.

**Related links**

- "Finding the UEFI diagnostic code" on page 776
- **80070202-0701ffff : Sensor Planar Fault has gone to Critical state from a less severe state.**

A voltage fault has been detected with the system board.

**Severity**

Error

**Serviceable**

Yes

**Automatically notify support**

No

**Alert Category**

Critical - Voltage

**SNMP Trap ID**

1

**CIM Information**

**Prefix:** PLAT ID: 0522

**User Response**

Complete the following steps:

1. Remove any recently installed components.
2. Try to power on the compute node.
  - If the compute node successfully powers on, complete the following steps:
    - a. Check the ServerProven website to make sure that recently installed components are compatible with the compute node.
    - b. Inspect the previously installed components for physical damage.
  - If the compute node does not successfully power on or if this is not the first occurrence of this problem, replace the system board.

- **8007020d-0b01ffff : Sensor [SensorElementName] has transitioned to critical from a less severe state.**

There is(are) failed drive(s) causing a RAID redundancy loss.

**Severity**

Error

**Serviceable**

Yes

**Automatically notify support**

No

**Alert Category**

Critical - Other

**SNMP Trap ID**

50

**CIM Information**

Prefix: PLAT ID: 0522

**User Response**

Check the physical drive(s) and replace the bad one(s).

- **8007020f-2201ffff : Sensor TXT ACM Module has transitioned to critical from a less severe state.**

TXT ACM Module or Drive Key Fault reports that it is above a normal state.

**Severity**

Error

**Serviceable**

Yes

**Automatically notify support**

No

**Alert Category**

Critical - Other

**SNMP Trap ID**

50

**CIM Information**

Prefix: PLAT ID: 0522

**User Response**

This is a UEFI detected event. The UEFI diagnostic code for this event can be found in the logged IMM message text. Please refer to the UEFI diagnostic code in the "UEFI diagnostic code" section of the Info Center for the appropriate user response.

**Related links**

– “Finding the UEFI diagnostic code” on page 776

- **8007020f-2582ffff : Sensor NO I/O Resources has transitioned to critical from a less severe state.**

An I/O resource conflict has been detected.

**Severity**

Error

**Serviceable**

Yes

**Automatically notify support**

No

**Alert Category**

Critical - Other

**SNMP Trap ID**

50

**CIM Information**

**Prefix:** PLAT ID: 0522

**User Response**

This is a UEFI detected event. The UEFI diagnostic code for this event can be found in the logged IMM message text. Please refer to the UEFI diagnostic code in the "UEFI diagnostic code" section of the Information Center for the appropriate user response.

**Related links**

- "Finding the UEFI diagnostic code" on page 776
- **80070217-2c01ffff : Sensor Mezz Exp 1 Fault has transitioned to critical from a less severe state.**  
The I/O expansion adapter in I/O expansion connector 1 has reported a fault.

**Severity**

Error

**Serviceable**

Yes

**Automatically notify support**

No

**Alert Category**

Critical - Other

**SNMP Trap ID**

50

**CIM Information**

**Prefix:** PLAT ID: 0522

**User Response**

Complete the following steps:

1. Remove any recently installed components.
  2. Try to power on the chassis.
    - If the chassis successfully powers on, complete the following steps:
      - a. Check the ServerProven website to make sure that recently installed components are compatible with the chassis.
      - b. Inspect the previously installed components for physical damage.
    - If the chassis does not successfully power on or if this is not the first occurrence of this problem, replace the I/O expansion adapter.
- **80070217-2c02ffff : Sensor Mezz Exp 2 Fault has transitioned to critical from a less severe state.**  
The I/O expansion adapter in I/O expansion connector 2 has reported a fault.

**Severity**

Error

**Serviceable**

Yes

**Automatically notify support**

No

**Alert Category**

Critical - Other

**SNMP Trap ID**

50

**CIM Information**

**Prefix: PLAT ID:** 0522

**User Response**

Complete the following steps:

1. Remove any recently installed components.
  2. Try to power on the chassis.
    - If the chassis successfully powers on, complete the following steps:
      - a. Check the ServerProven website to make sure that recently installed components are compatible with the chassis.
      - b. Inspect the previously installed components for physical damage.
    - If the chassis does not successfully power on or if this is not the first occurrence of this problem, replace the I/O expansion adapter.
- **80070217-2c03ffff : Sensor Mezz Exp 3 Fault has transitioned to critical from a less severe state.**  
The I/O expansion adapter in I/O expansion connector 3 has reported a fault.

**Severity**

Error

**Serviceable**

Yes

**Automatically notify support**

No

**Alert Category**

Critical - Other

**SNMP Trap ID**

50

**CIM Information**

**Prefix: PLAT ID:** 0522

**User Response**

Complete the following steps:

1. Remove any recently installed components.
  2. Try to power on the chassis.
    - If the chassis successfully powers on, complete the following steps:
      - a. Check the ServerProven website to make sure that recently installed components are compatible with the chassis.
      - b. Inspect the previously installed components for physical damage.
    - If the chassis does not successfully power on or if this is not the first occurrence of this problem, replace the I/O expansion adapter.
- **80070217-2c04ffff : Sensor Mezz Exp 4 Fault has transitioned to critical from a less severe state.**

The I/O expansion adapter in I/O expansion connector 4 has reported a fault.

**Severity**

Error

**Serviceable**

Yes

**Automatically notify support**

No

**Alert Category**

Critical - Other

**SNMP Trap ID**

50

**CIM Information**

**Prefix:** PLAT ID: 0522

**User Response**

Complete the following steps:

1. Remove any recently installed components.
  2. Try to power on the chassis.
    - If the chassis successfully powers on, complete the following steps:
      - a. Check the ServerProven website to make sure that recently installed components are compatible with the chassis.
      - b. Inspect the previously installed components for physical damage.
    - If the chassis does not successfully power on or if this is not the first occurrence of this problem, replace the I/O expansion adapter.
- **8007021b-0301ffff : Sensor CPU 1 QPILinkErr has transitioned to critical from a less severe state.**  
CPU 1 QPI Link Failure detected.

**Severity**

Error

**Serviceable**

Yes

**Automatically notify support**

Yes

**Alert Category**

Critical - Other

**SNMP Trap ID**

50

**CIM Information**

**Prefix:** PLAT ID: 0522

**User Response**

This is a UEFI detected event. The UEFI diagnostic code for this event can be found in the logged IMM message text. Please refer to the UEFI diagnostic code in the "UEFI diagnostic code" section of the Information Center for the appropriate user response.

**Related links**

- "Finding the UEFI diagnostic code" on page 776
- **8007021b-0302ffff : Sensor CPU 2 QPILinkErr has transitioned to critical from a less severe state.**

CPU 2 QPI Link Failure detected.

**Severity**

Error

**Serviceable**

Yes

**Automatically notify support**

Yes

**Alert Category**

Critical - Other

**SNMP Trap ID**

50

**CIM Information**

**Prefix:** PLAT ID: 0522

**User Response**

This is a UEFI detected event. The UEFI diagnostic code for this event can be found in the logged IMM message text. Please refer to the UEFI diagnostic code in the "UEFI diagnostic code" section of the Information Center for the appropriate user response.

**Related links**

– "Finding the UEFI diagnostic code" on page 776

- **8007021b-0303ffff : Sensor CPU 3 QPILinkErr has transitioned to critical from a less severe state.**

CPU 3 QPI Link Failure detected.

**Severity**

Error

**Serviceable**

Yes

**Automatically notify support**

Yes

**Alert Category**

Critical - Other

**SNMP Trap ID**

50

**CIM Information**

**Prefix:** PLAT ID: 0522

**User Response**

This is a UEFI detected event. The UEFI diagnostic code for this event can be found in the logged IMM message text. Please refer to the UEFI diagnostic code in the "UEFI diagnostic code" section of the Information Center for the appropriate user response.

**Related links**

– "Finding the UEFI diagnostic code" on page 776

- **8007021b-0304ffff : Sensor CPU 4 QPILinkErr has transitioned to critical from a less severe state.**

CPU 4 QPI Link Failure detected.

**Severity**

Error

**Serviceable**



Yes

**Automatically notify support**

Yes

**Alert Category**

Critical - Other

**SNMP Trap ID**

50

**CIM Information**

**Prefix:** PLAT ID: 0522

**User Response**

This is a UEFI detected event. The UEFI diagnostic code for this event can be found in the logged IMM message text. Please refer to the UEFI diagnostic code in the "UEFI diagnostic code" section of the Information Center for the appropriate user response.

**Related links**

– "Finding the UEFI diagnostic code" on page 776

- **80070301-030101ff : Sensor CPU 1 Overtemp has gone to Nonrecoverable state from a less severe state.**

The microprocessor 1 temperature has risen above its specified threshold, causing a hard shutdown of the node.

**Severity**

Error

**Serviceable**

Yes

**Automatically notify support**

No

**Alert Category**

Critical - Temperature

**SNMP Trap ID**

0

**CIM Information**

**Prefix:** PLAT ID: 0524

**User Response**

Complete the following steps until the problem is solved:

1. Check the Chassis Management Module or Flex System Manager event log for any fan- or cooling-related issues.
  2. Make sure that the airflow at the front and rear of the chassis is not obstructed and that fillers are in place and correctly installed.
  3. Make sure that the room temperature is within operating specifications.
  4. Make sure that the microprocessor 1 heat sink is securely installed.
  5. Make sure that the microprocessor 1 heat sink is installed correctly and the thermal material is correctly applied.
  6. Replace microprocessor 1.
- **80070301-0301ffff : Sensor CPU 1 Overtemp has gone to Nonrecoverable state from a less severe state.**

The microprocessor 1 temperature has risen above its specified threshold, causing a hard shutdown of the node.

**Severity**

Error

**Serviceable**

Yes

**Automatically notify support**

No

**Alert Category**

Critical - Temperature

**SNMP Trap ID**

0

**CIM Information**

**Prefix: PLAT ID:** 0524

**User Response**

Complete the following steps until the problem is solved:

1. Check the Chassis Management Module or Flex System Manager event log for any fan- or cooling-related issues.
  2. Make sure that the airflow at the front and rear of the chassis is not obstructed and that fillers are in place and correctly installed.
  3. Make sure that the room temperature is within operating specifications.
  4. Make sure that the microprocessor 1 heat sink is securely installed.
  5. Make sure that the microprocessor 1 heat sink is installed correctly and the thermal material is correctly applied.
  6. Replace microprocessor 1.
- **80070301-030201ff : Sensor CPU 2 Overtemp has gone to Nonrecoverable state from a less severe state.**

The temperature of microprocessor 2 has exceeded its specified threshold, causing a hard shutdown of the compute node.

**Severity**

Error

**Serviceable**

Yes

**Automatically notify support**

No

**Alert Category**

Critical - Temperature

**SNMP Trap ID**

0

**CIM Information**

**Prefix: PLAT ID:** 0524

**User Response**

Complete the following steps until the problem is solved:

1. Check the Chassis Management Module or Flex System Manager event log for any fan- or cooling-related issues.
  2. Make sure that the airflow at the front and rear of the chassis is not obstructed and that fillers are in place and correctly installed.
  3. Make sure that the room temperature is within operating specifications.
  4. Make sure that the microprocessor 2 heat sink is securely installed.
  5. Make sure that the microprocessor 2 heat sink is installed correctly and the thermal material is correctly applied.
  6. Replace microprocessor 2.
- **80070301-0302ffff : Sensor CPU 2 Overtemp has gone to Nonrecoverable state from a less severe state.**

The temperature of microprocessor 2 has exceeded its specified threshold, causing a hard shutdown of the compute node.

**Severity**

Error

**Serviceable**

Yes

**Automatically notify support**

No

**Alert Category**

Critical - Temperature

**SNMP Trap ID**

0

**CIM Information**

**Prefix:** PLAT ID: 0524

**User Response**

Complete the following steps until the problem is solved:

1. Check the Chassis Management Module or Flex System Manager event log for any fan- or cooling-related issues.
  2. Make sure that the airflow at the front and rear of the chassis is not obstructed and that fillers are in place and correctly installed.
  3. Make sure that the room temperature is within operating specifications.
  4. Make sure that the microprocessor 2 heat sink is securely installed.
  5. Make sure that the microprocessor 2 heat sink is installed correctly and the thermal material is correctly applied.
  6. Replace microprocessor 2.
- **80070301-030301ff : Sensor CPU 3 Overtemp has gone to Nonrecoverable state from a less severe state.**

The temperature of microprocessor 3 has exceeded its specified threshold, causing a hard shutdown of the compute node.

**Severity**

Error

**Serviceable**

Yes

**Automatically notify support**

No

**Alert Category**

Critical - Temperature

**SNMP Trap ID**

0

**CIM Information**

**Prefix:** PLAT ID: 0524

**User Response**

Complete the following steps until the problem is solved:

1. Check the Chassis Management Module or Flex System Manager event log for any fan- or cooling-related issues.
  2. Make sure that the airflow at the front and rear of the chassis is not obstructed and that fillers are in place and correctly installed.
  3. Make sure that the room temperature is within operating specifications.
  4. Make sure that the microprocessor 3 heat sink is securely installed.
  5. Make sure that the microprocessor 3 heat sink is installed correctly and the thermal material is correctly applied.
  6. Replace microprocessor 3.
- **80070301-0303ffff : Sensor CPU 3 Overtemp has gone to Nonrecoverable state from a less severe state.**

The temperature of microprocessor 3 has exceeded its specified threshold, causing a hard shutdown of the compute node.

**Severity**

Error

**Serviceable**

Yes

**Automatically notify support**

No

**Alert Category**

Critical - Temperature

**SNMP Trap ID**

0

**CIM Information**

**Prefix:** PLAT ID: 0524

**User Response**

Complete the following steps until the problem is solved:

1. Check the Chassis Management Module or Flex System Manager event log for any fan- or cooling-related issues.
2. Make sure that the airflow at the front and rear of the chassis is not obstructed and that fillers are in place and correctly installed.
3. Make sure that the room temperature is within operating specifications.
4. Make sure that the microprocessor 3 heat sink is securely installed.
5. Make sure that the microprocessor 3 heat sink is installed correctly and the thermal material is correctly applied.

6. Replace microprocessor 3.

- **80070301-030401ff : Sensor CPU 4 Overtemp has gone to Nonrecoverable state from a less severe state.**

The temperature of microprocessor 4 has exceeded its specified threshold, causing a hard shutdown of the compute node.

**Severity**

Error

**Serviceable**

Yes

**Automatically notify support**

No

**Alert Category**

Critical - Temperature

**SNMP Trap ID**

0

**CIM Information**

**Prefix:** PLAT ID: 0524

**User Response**

Complete the following steps until the problem is solved:

1. Check the Chassis Management Module or Flex System Manager event log for any fan- or cooling-related issues.
2. Make sure that the airflow at the front and rear of the chassis is not obstructed and that fillers are in place and correctly installed.
3. Make sure that the room temperature is within operating specifications.
4. Make sure that the microprocessor 4 heat sink is securely installed.
5. Make sure that the microprocessor 4 heat sink is installed correctly and the thermal material is correctly applied.
6. Replace microprocessor 4.

- **80070301-030402ff : Sensor CPU 4 Overtemp has gone to Nonrecoverable state from a less severe state.**

The temperature of microprocessor 4 has exceeded its specified threshold, causing a hard shutdown of the compute node.

**Severity**

Error

**Serviceable**

Yes

**Automatically notify support**

No

**Alert Category**

Critical - Temperature

**SNMP Trap ID**

0

**CIM Information**

**Prefix:** PLAT ID: 0524

### User Response

Complete the following steps until the problem is solved:

1. Check the Chassis Management Module or Flex System Manager event log for any fan- or cooling-related issues.
  2. Make sure that the airflow at the front and rear of the chassis is not obstructed and that fillers are in place and correctly installed.
  3. Make sure that the room temperature is within operating specifications.
  4. Make sure that the microprocessor 4 heat sink is securely installed.
  5. Make sure that the microprocessor 4 heat sink is installed correctly and the thermal material is correctly applied.
  6. Replace microprocessor 4.
- **80070301-0304ffff : Sensor CPU 4 Overtemp has gone to Nonrecoverable state from a less severe state.**

The temperature of microprocessor 4 has exceeded its specified threshold, causing a hard shutdown of the compute node.

### Severity

Error

### Serviceable

Yes

### Automatically notify support

No

### Alert Category

Critical - Temperature

### SNMP Trap ID

0

### CIM Information

Prefix: PLAT ID: 0524

### User Response

Complete the following steps until the problem is solved:

1. Check the Chassis Management Module or Flex System Manager event log for any fan- or cooling-related issues.
  2. Make sure that the airflow at the front and rear of the chassis is not obstructed and that fillers are in place and correctly installed.
  3. Make sure that the room temperature is within operating specifications.
  4. Make sure that the microprocessor 4 heat sink is securely installed.
  5. Make sure that the microprocessor 4 heat sink is installed correctly and the thermal material is correctly applied.
  6. Replace microprocessor 4.
- **80070301-2c01ffff : Sensor Mezz Exp 1 temp has transitioned to non-recoverable from a less severe state.**

The temperature of the I/O expansion adapter in I/O expansion connector 1 has exceeded its specified threshold. The compute node has attempted a soft shutdown.

### Severity

Error

### Serviceable

Yes

**Automatically notify support**

No

**Alert Category**

Critical - Temperature

**SNMP Trap ID**

0

**CIM Information**

**Prefix:** PLAT ID: 0524

**User Response**

Complete the following steps until the problem is solved:

1. Check the Chassis Management Module or Flex System Manager event log for any fan- or cooling-related issues.
  2. Make sure that the airflow at the front and rear of the chassis is not obstructed and that fillers are in place and correctly installed.
  3. Make sure that the room temperature is within operating specifications.
  4. If there are no other thermal issues, replace the I/O expansion adapter.
- **80070301-2c02ffff : Sensor Mezz Exp 2 temp has transitioned to non-recoverable from a less severe state.**

The temperature of the I/O expansion adapter in I/O expansion connector 2 has exceeded its specified threshold. The compute node has attempted a soft shutdown.

**Severity**

Error

**Serviceable**

Yes

**Automatically notify support**

No

**Alert Category**

Critical - Temperature

**SNMP Trap ID**

0

**CIM Information**

**Prefix:** PLAT ID: 0524

**User Response**

Complete the following steps until the problem is solved:

1. Check the Chassis Management Module or Flex System Manager event log for any fan- or cooling-related issues.
  2. Make sure that the airflow at the front and rear of the chassis is not obstructed and that fillers are in place and correctly installed.
  3. Make sure that the room temperature is within operating specifications.
  4. If there are no other thermal issues, replace the I/O expansion adapter.
- **80070301-2c03ffff : Sensor Mezz Exp 3 temp has transitioned to non-recoverable from a less severe state.**

The temperature of the I/O expansion adapter in I/O expansion connector 3 has exceeded its specified threshold. The compute node has attempted a soft shutdown.

**Severity**

Error

**Serviceable**

Yes

**Automatically notify support**

No

**Alert Category**

Critical - Temperature

**SNMP Trap ID**

0

**CIM Information**

**Prefix: PLAT ID:** 0524

**User Response**

Complete the following steps until the problem is solved:

1. Check the Chassis Management Module or Flex System Manager event log for any fan- or cooling-related issues.
  2. Make sure that the airflow at the front and rear of the chassis is not obstructed and that fillers are in place and correctly installed.
  3. Make sure that the room temperature is within operating specifications.
  4. If there are no other thermal issues, replace the I/O expansion adapter.
- **80070301-2c0402ff : Sensor Mezz Exp 4 temp has transitioned to non-recoverable from a less severe state.**

The temperature of the I/O expansion adapter in I/O expansion connector 4 has exceeded its specified threshold. The compute node has attempted a soft shutdown.

**Severity**

Error

**Serviceable**

Yes

**Automatically notify support**

No

**Alert Category**

Critical - Temperature

**SNMP Trap ID**

0

**CIM Information**

**Prefix: PLAT ID:** 0524

**User Response**

Complete the following steps until the problem is solved:

1. Check the Chassis Management Module or Flex System Manager event log for any fan- or cooling-related issues.
2. Make sure that the airflow at the front and rear of the chassis is not obstructed and that fillers are in place and correctly installed.
3. Make sure that the room temperature is within operating specifications.
4. If there are no other thermal issues, replace the I/O expansion adapter.



- **80070301-2c04ffff : Sensor Mezz Exp 4 temp has transitioned to non-recoverable from a less severe state.**

The temperature of the I/O expansion adapter in I/O expansion connector 4 has exceeded its specified threshold. The compute node has attempted a soft shutdown.

**Severity**

Error

**Serviceable**

Yes

**Automatically notify support**

No

**Alert Category**

Critical - Temperature

**SNMP Trap ID**

0

**CIM Information**

**Prefix:** PLAT ID: 0524

**User Response**

Complete the following steps until the problem is solved:

1. Check the Chassis Management Module or Flex System Manager event log for any fan- or cooling-related issues.
  2. Make sure that the airflow at the front and rear of the chassis is not obstructed and that fillers are in place and correctly installed.
  3. Make sure that the room temperature is within operating specifications.
  4. If there are no other thermal issues, replace the I/O expansion adapter.
- **80070301-2d01ffff : Sensor PCH Overtemp has transitioned to non-recoverable from a less severe state.**

A temperature has exceeded its specified threshold. The compute node will attempt a soft shutdown.

**Severity**

Error

**Serviceable**

Yes

**Automatically notify support**

No

**Alert Category**

Critical - Temperature

**SNMP Trap ID**

0

**CIM Information**

**Prefix:** PLAT ID: 0524

**User Response**

Complete the following steps until the problem is solved:

1. Check the Chassis Management Module or Flex System Manager event log for any fan- or cooling-related issues.

2. Make sure that the airflow at the front and rear of the chassis is not obstructed and that fillers are in place and correctly installed.
  3. Make sure that the room temperature is within operating specifications.
- **8007030d-0b01ffff : Sensor [SensorElementName] has transitioned to non-recoverable from a less severe state.**

There is(are) failed drive(s) causing RAID offline and data lost.

**Severity**

Error

**Serviceable**

Yes

**Automatically notify support**

No

**Alert Category**

Critical - Other

**SNMP Trap ID**

50

**CIM Information**

**Prefix: PLAT ID:** 0524

**User Response**

Check the physical drive(s) and replace the bad one(s).

- **80070401-2c01ffff : Sensor Mezz Exp 1 temp has transitioned to non-critical from a more severe state.**

The previously high temperature of the I/O expansion adapter in I/O expansion connector 1 has returned to below its specified threshold.

**Severity**

Info

**Serviceable**

No

**Automatically notify support**

No

**Alert Category**

System - Other

**SNMP Trap ID**

22

**CIM Information**

**Prefix: PLAT ID:** 0526

**User Response**

Information only; no action is required.

- **80070401-2c02ffff : Sensor Mezz Exp 2 temp has transitioned to non-critical from a more severe state.**

The previously high temperature of the I/O expansion adapter in I/O expansion connector 2 has returned to below its specified threshold.

**Severity**

Info

**Serviceable**

No

**Automatically notify support**

No

**Alert Category**

System - Other

**SNMP Trap ID**

22

**CIM Information**

Prefix: PLAT ID: 0526

**User Response**

Information only; no action is required.

- **80070401-2c03ffff : Sensor Mezz Exp 3 temp has transitioned to non-critical from a more severe state.**

The previously high temperature of the I/O expansion adapter in I/O expansion connector 3 has returned to below its specified threshold.

**Severity**

Info

**Serviceable**

No

**Automatically notify support**

No

**Alert Category**

System - Other

**SNMP Trap ID**

22

**CIM Information**

Prefix: PLAT ID: 0526

**User Response**

Information only; no action is required.

- **80070401-2c04ffff : Sensor Mezz Exp 4 temp has transitioned to non-critical from a more severe state.**

The previously high temperature of the I/O expansion adapter in I/O expansion connector 4 has returned to below its specified threshold.

**Severity**

Info

**Serviceable**

No

**Automatically notify support**

No

**Alert Category**

System - Other

**SNMP Trap ID**

22

**CIM Information**

Prefix: PLAT ID: 0526

**User Response**

Information only; no action is required.

- **80070601-2c01ffff : Sensor Mezz Exp 1 temp has transitioned to non-recoverable.**

The temperature of the I/O expansion adapter in I/O expansion connector 1 has exceeded its specified threshold. The compute node has attempted a soft shutdown.

**Severity**

Error

**Serviceable**

Yes

**Automatically notify support**

No

**Alert Category**

Critical - Temperature

**SNMP Trap ID**

0

**CIM Information**

Prefix: PLAT ID: 0530

**User Response**

Complete the following steps until the problem is solved:

1. Check the Chassis Management Module or Flex System Manager event log for any fan- or cooling-related issues.
  2. Make sure that the airflow at the front and rear of the chassis is not obstructed and that fillers are in place and correctly installed.
  3. Make sure that the room temperature is within operating specifications.
  4. If there are no other thermal issues, replace the I/O expansion adapter.
- **80070601-2c02ffff : Sensor Mezz Exp 2 temp has transitioned to non-recoverable.**

The temperature of the I/O expansion adapter in I/O expansion connector 2 has exceeded its specified threshold. The compute node has attempted a soft shutdown.

**Severity**

Error

**Serviceable**

Yes

**Automatically notify support**

No

**Alert Category**

Critical - Temperature

**SNMP Trap ID**

0

**CIM Information**

Prefix: PLAT ID: 0530

**User Response**

Complete the following steps until the problem is solved:

1. Check the Chassis Management Module or Flex System Manager event log for any fan- or cooling-related issues.
  2. Make sure that the airflow at the front and rear of the chassis is not obstructed and that fillers are in place and correctly installed.
  3. Make sure that the room temperature is within operating specifications.
  4. If there are no other thermal issues, replace the I/O expansion adapter.
- **80070601-2c03ffff : Sensor Mezz Exp 3 temp has transitioned to non-recoverable.**

The temperature of the I/O expansion adapter in I/O expansion connector 3 has exceeded its specified threshold. The compute node has attempted a soft shutdown.

**Severity**

Error

**Serviceable**

Yes

**Automatically notify support**

No

**Alert Category**

Critical - Temperature

**SNMP Trap ID**

0

**CIM Information**

**Prefix:** PLAT ID: 0530

**User Response**

Complete the following steps until the problem is solved:

1. Check the Chassis Management Module or Flex System Manager event log for any fan- or cooling-related issues.
  2. Make sure that the airflow at the front and rear of the chassis is not obstructed and that fillers are in place and correctly installed.
  3. Make sure that the room temperature is within operating specifications.
  4. If there are no other thermal issues, replace the I/O expansion adapter.
- **80070601-2c04ffff : Sensor Mezz Exp 4 temp has transitioned to non-recoverable.**

The temperature of the I/O expansion adapter in I/O expansion connector 4 has exceeded its specified threshold. The compute node has attempted a soft shutdown.

**Severity**

Error

**Serviceable**

Yes

**Automatically notify support**

No

**Alert Category**

Critical - Temperature

**SNMP Trap ID**

0

**CIM Information**

**Prefix:** PLAT ID: 0530

### User Response

Complete the following steps until the problem is solved:

1. Check the Chassis Management Module or Flex System Manager event log for any fan- or cooling-related issues.
  2. Make sure that the airflow at the front and rear of the chassis is not obstructed and that fillers are in place and correctly installed.
  3. Make sure that the room temperature is within operating specifications.
  4. If there are no other thermal issues, replace the I/O expansion adapter.
- **8007060f-2201ffff : Sensor BOFM Config Err has transitioned to non-recoverable.**  
UEFI cannot read the fabric manager configuration from the IMM.

### Severity

Error

### Serviceable

Yes

### Automatically notify support

No

### Alert Category

Critical - Other

### SNMP Trap ID

50

### CIM Information

Prefix: PLAT ID: 0530

### User Response

This is a UEFI detected event. The UEFI diagnostic code for this event can be found in the logged IMM message text. Please refer to the UEFI diagnostic code in the "UEFI diagnostic code" section of the Information Center for the appropriate user response.

### Related links

- "Finding the UEFI diagnostic code" on page 776
- **80070614-2201ffff : Sensor TPM Phy Pres Set has transitioned to non-recoverable.**  
Trusted Platform Module (TPM) initialization error.

### Severity

Error

### Serviceable

Yes

### Automatically notify support

No

### Alert Category

Critical - Other

### SNMP Trap ID

50

### CIM Information

Prefix: PLAT ID: 0530

### User Response

This is a UEFI detected event. The UEFI diagnostic code for this event can be found in the logged IMM message text. Please refer to the UEFI diagnostic code in the "UEFI diagnostic code" section of the Info Center for the appropriate user response.

**Related links**

– “Finding the UEFI diagnostic code” on page 776

- **80070617-2c01ffff : Sensor Mezz Exp 1 Fault has transitioned to non-recoverable.**

A problem has been detected in the I/O expansion adapter in I/O expansion connector 1. The adapter is unable to initialize.

**Severity**

Error

**Serviceable**

Yes

**Automatically notify support**

No

**Alert Category**

Critical - Other

**SNMP Trap ID**

50

**CIM Information**

**Prefix:** PLAT ID: 0530

**User Response**

Complete the following steps:

1. Remove the I/O expansion adapter in I/O expansion connector 1.
  2. Try to power on the chassis.
    - If the chassis successfully powers on, complete the following steps:
      - a. Check the ServerProven website to make sure that recently installed components are compatible with the chassis.
      - b. Inspect the previously installed components for physical damage.
    - If the chassis does not successfully power on or if this is not the first occurrence of this problem, replace the I/O expansion adapter.
- **80070617-2c02ffff : Sensor Mezz Exp 2 Fault has transitioned to non-recoverable.**

A problem was detected in the I/O expansion adapter in I/O expansion connector 2. The adapter is unable to initialize.

**Severity**

Error

**Serviceable**

Yes

**Automatically notify support**

No

**Alert Category**

Critical - Other

**SNMP Trap ID**

50

**CIM Information**

**Prefix: PLAT ID:** 0530

### User Response

Complete the following steps:

1. Remove the I/O expansion adapter in I/O expansion connector 2.
2. Try to power on the chassis.
  - If the chassis successfully powers on, complete the following steps:
    - a. Check the ServerProven website to make sure that recently installed components are compatible with the chassis.
    - b. Inspect the previously installed components for physical damage.
  - If the chassis does not successfully power on or if this is not the first occurrence of this problem, replace the I/O expansion adapter.

- **80070617-2c03ffff : Sensor Mezz Exp 3 Fault has transitioned to non-recoverable.**

A problem was detected in the I/O expansion adapter in I/O expansion connector 3. The adapter is unable to initialize.

### Severity

Error

### Serviceable

Yes

### Automatically notify support

No

### Alert Category

Critical - Other

### SNMP Trap ID

50

### CIM Information

**Prefix: PLAT ID:** 0530

### User Response

Complete the following steps:

1. Remove the I/O expansion adapter in I/O expansion connector 3.
2. Try to power on the chassis.
  - If the chassis successfully powers on, complete the following steps:
    - a. Check the ServerProven website to make sure that recently installed components are compatible with the chassis.
    - b. Inspect the previously installed components for physical damage.
  - If the chassis does not successfully power on or if this is not the first occurrence of this problem, replace the I/O expansion adapter.

- **80070617-2c04ffff : Sensor Mezz Exp 4 Fault has transitioned to non-recoverable.**

A problem was detected in the I/O expansion adapter in I/O expansion connector 4. The adapter is unable to initialize.

### Severity

Error

### Serviceable

Yes



**Automatically notify support**

No

**Alert Category**

Critical - Other

**SNMP Trap ID**

50

**CIM Information**

**Prefix:** PLAT ID: 0530

**User Response**

Complete the following steps:

1. Remove the I/O expansion adapter in I/O expansion connector 4.
  2. Try to power on the chassis.
    - If the chassis successfully powers on, complete the following steps:
      - a. Check the ServerProven website to make sure that recently installed components are compatible with the chassis.
      - b. Inspect the previously installed components for physical damage.
    - If the chassis does not successfully power on or if this is not the first occurrence of this problem, replace the I/O expansion adapter.
- **8008001b-1f07ffff : Device Periscope 1 has been removed from unit [PhysicalPackageElementName].**

The fabric connector for LAN On Motherboard (LOM) in location 1 is not present.

**Severity**

Info

**Serviceable**

No

**Automatically notify support**

No

**Alert Category**

System - Other

**SNMP Trap ID****CIM Information**

**Prefix:** PLAT ID: 0537

**User Response**

Informational message.

On a LOM model compute node, if you are utilizing LOM and it is not working ensure you have the necessary fabric connector installed.

- To utilize the LOM:
  - have the LOM model compute node
  - have the corresponding fabric connector installed
- Information regarding the fabric connectors:
  - LOM 1 utilizes the fabric connector in location 1.
  - LOM 2 utilizes the fabric connector in location 2.

- I/O expansion adaptor in I/O expansion slot 1 and the fabric connector in slot 1 utilize the same connector and only one of the two can be installed at a time.
  - I/O expansion adaptor in I/O expansion slot 3 and the fabric connector in slot 2 utilize the same connector and only one of the two can be installed at a time.
- **8008001b-1f08ffff : Device Periscope 2 has been removed from unit [PhysicalPackageElementName].**

The fabric connector for LAN On Motherboard (LOM) in location 2 is not present.

**Severity**

Info

**Serviceable**

No

**Automatically notify support**

No

**Alert Category**

System - Other

**SNMP Trap ID**

**CIM Information**

Prefix: PLAT ID: 0537

**User Response**

Informational message.

On a LOM model compute node, if you are utilizing LOM and it is not working ensure you have the necessary fabric connector installed.

- To utilize the LOM:
  - have the LOM model compute node
  - have the corresponding fabric connector installed
- Information regarding the fabric connectors:
  - LOM 1 utilizes the fabric connector in location 1.
  - LOM 2 utilizes the fabric connector in location 2.
  - I/O expansion adaptor in I/O expansion slot 1 and the fabric connector in slot 1 utilize the same connector and only one of the two can be installed at a time.
  - I/O expansion adaptor in I/O expansion slot 3 and the fabric connector in slot 2 utilize the same connector and only one of the two can be installed at a time.
- **8008010f-2101ffff : Device [LogicalDeviceElementName] has been added.**

The physical presence jumper has been installed in the compute node.

**Severity**

Info

**Serviceable**

No

**Automatically notify support**

No

**Alert Category**

System - Other

**SNMP Trap ID**

**CIM Information**

Prefix: PLAT ID: 0536

**User Response**

Information only; no action is required.

- **8008011b-1f07ffff : Device [LogicalDeviceElementName] has been added.**

The fabric connector for LAN On Motherboard (LOM) in location 1 is present.

**Severity**

Info

**Serviceable**

No

**Automatically notify support**

No

**Alert Category**

System - Other

**SNMP Trap ID****CIM Information**

Prefix: PLAT ID: 0536

**User Response**

Informational message.

On a LOM model compute node, if you are utilizing LOM and it is not working ensure you have the necessary fabric connector installed.

- To utilize the LOM:
    - have the LOM model compute node
    - have the corresponding fabric connector installed
  - Information regarding the fabric connectors:
    - LOM 1 utilizes the fabric connector in location 1.
    - LOM 2 utilizes the fabric connector in location 2.
    - I/O expansion adaptor in I/O expansion slot 1 and the fabric connector in slot 1 utilize the same connector and only one of the two can be installed at a time.
    - I/O expansion adaptor in I/O expansion slot 3 and the fabric connector in slot 2 utilize the same connector and only one of the two can be installed at a time.
- **8008011b-1f08ffff : Device [LogicalDeviceElementName] has been added.**

The fabric connector for LAN On Motherboard (LOM) in location 2 is present.

**Severity**

Info

**Serviceable**

No

**Automatically notify support**

No

**Alert Category**

System - Other

**SNMP Trap ID**

**CIM Information**

Prefix: PLAT ID: 0536

**User Response**

Informational message.

On a LOM model compute node, if you are utilizing LOM and it is not working ensure you have the necessary fabric connector installed.

- To utilize the LOM:
  - have the LOM model compute node
  - have the corresponding fabric connector installed
- Information regarding the fabric connectors:
  - LOM 1 utilizes the fabric connector in location 1.
  - LOM 2 utilizes the fabric connector in location 2.
  - I/O expansion adaptor in I/O expansion slot 1 and the fabric connector in slot 1 utilize the same connector and only one of the two can be installed at a time.
  - I/O expansion adaptor in I/O expansion slot 3 and the fabric connector in slot 2 utilize the same connector and only one of the two can be installed at a time.

- **80080128-2101ffff : Device [LogicalDeviceElementName] has been added.**

The specified device has been installed in the compute node.

**Severity**

Info

**Serviceable**

No

**Automatically notify support**

No

**Alert Category**

System - Other

**SNMP Trap ID****CIM Information**

Prefix: PLAT ID: 0536

**User Response**

Information only; no action is required.

- **8009000c-0701ffff : Device Performance Mode has been disabled.**

The user has switched from Performance mode to Acoustic mode.

**Severity**

Info

**Serviceable**

No

**Automatically notify support**

No

**Alert Category**

System - Other

**SNMP Trap ID**

**CIM Information**

Prefix: PLAT ID: 0539

**User Response**

Information only; no action is required.

- **8009010c-0701ffff : Device Performance Mode has been enabled.**

The user has switched from Acoustic mode to Performance mode.

**Severity**

Info

**Serviceable**

No

**Automatically notify support**

No

**Alert Category**

System - Other

**SNMP Trap ID****CIM Information**

Prefix: PLAT ID: 0538

**User Response**

Information only; no action is required.

- **80090112-2101ffff : Device [LogicalDeviceElementName] has been enabled.**

An IPMI or SNMP Account has been enabled.

**Severity**

Info

**Serviceable**

No

**Automatically notify support**

No

**Alert Category**

System - Other

**SNMP Trap ID****CIM Information**

Prefix: PLAT ID: 0538

**User Response**

Information only; no action is required.

- **800b010c-2581ffff : Redundancy Lost for [RedundancySetElementName] has asserted.**

Redundancy has been lost.

**Severity**

Error

**Serviceable**

Yes

**Automatically notify support**

No

**Alert Category**

Critical - Memory

**SNMP Trap ID**

41

**CIM Information**

Prefix: PLAT ID: 0802

**User Response**

This is a UEFI detected event. The UEFI diagnostic code for this event can be found in the logged IMM message text. Please refer to the UEFI diagnostic code in the "UEFI diagnostic code" section of the Information Center for the appropriate user response.

**Related links**

– “Finding the UEFI diagnostic code” on page 776

- **800b030c-2581ffff : Non-redundant:Sufficient Resources from Redundancy Degraded or Fully Redundant for [RedundancySetElementName] has asserted.**

Redundancy has transitioned from Redundancy Degraded or Fully Redundant to Non-redundant: Sufficient.

**Severity**

Warning

**Serviceable**

Yes

**Automatically notify support**

No

**Alert Category**

Warning - Memory

**SNMP Trap ID**

43

**CIM Information**

Prefix: PLAT ID: 0806

**User Response**

This is a UEFI detected event. The UEFI diagnostic code for this event can be found in the logged IMM message text. Please refer to the UEFI diagnostic code in the "UEFI diagnostic code" section of the Information Center for the appropriate user response.

**Related links**

– “Finding the UEFI diagnostic code” on page 776

- **800b050c-2581ffff : Non-redundant:Insufficient Resources for [RedundancySetElementName] has asserted.**

There are insufficient resources for the Backup Memory to have redundancy.

**Severity**

Error

**Serviceable**

Yes

**Automatically notify support**

No

**Alert Category**

Critical - Memory

**SNMP Trap ID**

41

**CIM Information**

**Prefix:** PLAT ID: 0810

**User Response**

This is a UEFI detected event. The UEFI diagnostic code for this event can be found in the logged IMM message text. Please refer to the UEFI diagnostic code in the "UEFI diagnostic code" section of the Information Center for the appropriate user response.

**Related links**

– “Finding the UEFI diagnostic code” on page 776

- **806f0007-0301ffff : CPU 1 has Failed with IERR.**

A Processor has Failed - IERR Condition.

**Severity**

Error

**Serviceable**

Yes

**Automatically notify support**

No

**Alert Category**

Critical - CPU

**SNMP Trap ID**

40

**CIM Information**

**Prefix:** PLAT ID: 0042

**User Response**

This is a UEFI detected event. The UEFI diagnostic code for this event can be found in the logged IMM message text. Please refer to the UEFI diagnostic code in the "UEFI diagnostic code" section of the Information Center for the appropriate user response.

**Related links**

– “Finding the UEFI diagnostic code” on page 776

- **806f0007-0302ffff : CPU 2 has Failed with IERR.**

A Processor has Failed - IERR Condition.

**Severity**

Error

**Serviceable**

Yes

**Automatically notify support**

No

**Alert Category**

Critical - CPU

**SNMP Trap ID**

40

**CIM Information**

**Prefix:** PLAT ID: 0042

**User Response**

This is a UEFI detected event. The UEFI diagnostic code for this event can be found in the logged IMM message text. Please refer to the UEFI diagnostic code in the "UEFI diagnostic code" section of the Information Center for the appropriate user response.

**Related links**

– "Finding the UEFI diagnostic code" on page 776

- **806f0007-0303ffff : CPU 3 has Failed with IERR.**

A Processor has Failed - IERR Condition.

**Severity**

Error

**Serviceable**

Yes

**Automatically notify support**

No

**Alert Category**

Critical - CPU

**SNMP Trap ID**

40

**CIM Information**

**Prefix:** PLAT ID: 0042

**User Response**

This is a UEFI detected event. The UEFI diagnostic code for this event can be found in the logged IMM message text. Please refer to the UEFI diagnostic code in the "UEFI diagnostic code" section of the Information Center for the appropriate user response.

**Related links**

– "Finding the UEFI diagnostic code" on page 776

- **806f0007-0304ffff : CPU 4 has Failed with IERR.**

A Processor has Failed - IERR Condition.

**Severity**

Error

**Serviceable**

Yes

**Automatically notify support**

No

**Alert Category**

Critical - CPU

**SNMP Trap ID**

40

**CIM Information**

**Prefix:** PLAT ID: 0042

**User Response**

This is a UEFI detected event. The UEFI diagnostic code for this event can be found in the logged IMM message text. Please refer to the UEFI diagnostic code in the "UEFI diagnostic code" section of the Information Center for the appropriate user response.



**Related links**

- "Finding the UEFI diagnostic code" on page 776

- **806f0009-0701ffff : system board 1 has been turned off.**

The compute node has been powered off.

**Severity**

Info

**Serviceable**

No

**Automatically notify support**

No

**Alert Category**

System - Power Off

**SNMP Trap ID**

23

**CIM Information**

Prefix: PLAT ID: 0106

**User Response**

Information only; no action is required.

- **806f000d-0400ffff : The Drive Drive 0 has been added.**

Hard disk drive 0 has been installed.

**Severity**

Info

**Serviceable**

No

**Automatically notify support**

No

**Alert Category**

System - Other

**SNMP Trap ID**

22

**CIM Information**

Prefix: PLAT ID: 0162

**User Response**

Information only; no action is required.

- **806f000d-0401ffff : The Drive Drive 1 has been added.**

Hard disk drive 1 has been installed.

**Severity**

Info

**Serviceable**

No

**Automatically notify support**

No

**Alert Category**

System - Other

**SNMP Trap ID**

22

**CIM Information**

**Prefix: PLAT ID:** 0162

**User Response**

Information only; no action is required.

- **806f000d-0402ffff : The Drive Drive 2 has been added.**

Hard disk drive 2 has been installed.

**Severity**

Info

**Serviceable**

No

**Automatically notify support**

No

**Alert Category**

System - Other

**SNMP Trap ID**

22

**CIM Information**

**Prefix: PLAT ID:** 0162

**User Response**

Information only; no action is required.

- **806f000d-0403ffff : The Drive Drive 3 has been added.**

Hard disk drive 3 has been installed.

**Severity**

Info

**Serviceable**

No

**Automatically notify support**

No

**Alert Category**

System - Other

**SNMP Trap ID**

22

**CIM Information**

**Prefix: PLAT ID:** 0162

**User Response**

Information only; no action is required.

- **806f000d-0404ffff : The Drive Drive 4 has been added.**

Hard disk drive 4 has been installed.

**Severity**

Info

**Serviceable**

No

**Automatically notify support**

No

**Alert Category**

System - Other

**SNMP Trap ID**

22

**CIM Information**

Prefix: PLAT ID: 0162

**User Response**

Information only; no action is required.

- **806f000d-0405ffff : The Drive [StorageVolumeElementName] has been added.**

Hard disk drive 5 has been installed.

**Severity**

Info

**Serviceable**

No

**Automatically notify support**

No

**Alert Category**

System - Other

**SNMP Trap ID**

22

**CIM Information**

Prefix: PLAT ID: 0162

**User Response**

Information only; no action is required.

- **806f000d-0406ffff : The Drive Drive 6 has been added.**

Hard disk drive 6 has been installed.

**Severity**

Info

**Serviceable**

No

**Automatically notify support**

No

**Alert Category**

System - Other

**SNMP Trap ID**

22

**CIM Information**

Prefix: PLAT ID: 0162

**User Response**

Information only; no action is required.

- **806f000d-0407ffff : The Drive Drive 7 has been added.**

Hard disk drive 7 has been installed.

**Severity**

Info

**Serviceable**

No

**Automatically notify support**

No

**Alert Category**

System - Other

**SNMP Trap ID**

22

**CIM Information**

Prefix: PLAT ID: 0162

**User Response**

Information only; no action is required.

- **806f000f-220100ff : The System [ComputerSystemElementName] encountered a POST Error.**

A Post Error has been detected. ABR Status. Firmware Error.

**Severity**

Error

**Serviceable**

Yes

**Automatically notify support**

No

**Alert Category**

Critical - Other

**SNMP Trap ID**

50

**CIM Information**

Prefix: PLAT ID: 0184

**User Response**

This is a UEFI detected event. The UEFI diagnostic code for this event can be found in the logged IMM message text. Please refer to the UEFI diagnostic code in the "UEFI diagnostic code" section of the Information Center for the appropriate user response.

**Related links**

- "Finding the UEFI diagnostic code" on page 776

- **806f000f-220101ff : The System [ComputerSystemElementName] has detected no memory in the system.**

No memory was detected in the system.

**Severity**

Error

**Serviceable**

Yes

**Automatically notify support**

No

**Alert Category**

Critical - Memory

**SNMP Trap ID**

41

**CIM Information**

**Prefix:** PLAT ID: 0794

**User Response**

This is a UEFI detected event. The UEFI diagnostic code for this event can be found in the logged IMM message text. Please refer to the UEFI diagnostic code in the "UEFI diagnostic code" section of the Information Center for the appropriate user response.

**Related links**

- "Finding the UEFI diagnostic code" on page 776
- **806f000f-220102ff : Subsystem [MemoryElementName] has insufficient memory for operation.**

The usable Memory is insufficient for operation.

**Severity**

Error

**Serviceable**

Yes

**Automatically notify support**

No

**Alert Category**

Critical - Memory

**SNMP Trap ID**

41

**CIM Information**

**Prefix:** PLAT ID: 0132

**User Response**

This is a UEFI detected event. The UEFI diagnostic code for this event can be found in the logged IMM message text. Please refer to the UEFI diagnostic code in the "UEFI diagnostic code" section of the Information Center for the appropriate user response.

**Related links**

- "Finding the UEFI diagnostic code" on page 776
- **806f000f-220103ff : The System [ComputerSystemElementName] encountered firmware error - unrecoverable boot device failure.**

A System Firmware Error Unrecoverable boot device failure has occurred.

**Severity**

Error

**Serviceable**

Yes

**Automatically notify support**

No

**Alert Category**

Critical - Hard Disk drive

**SNMP Trap ID**

5

**CIM Information**

Prefix: PLAT ID: 0770

**User Response**

ABR Status : Firmware Error : This is a UEFI detected event. The UEFI diagnostic code for this event can be found in the logged IMM message text. Please refer to the UEFI diagnostic code in the "UEFI diagnostic code" section of the Information Center for the appropriate user response.

**Related links**

– “Finding the UEFI diagnostic code” on page 776

- **806f000f-220104ff : The System [ComputerSystemElementName]has encountered a motherboard failure.**

A fatal motherboard failure has been detected in the system due to ABR Status or Firmware Error.

**Severity**

Error

**Serviceable**

Yes

**Automatically notify support**

No

**Alert Category**

Critical - Other

**SNMP Trap ID**

50

**CIM Information**

Prefix: PLAT ID: 0795

**User Response**

This is a UEFI detected event. The UEFI diagnostic code for this event can be found in the logged IMM message text. Please refer to the UEFI diagnostic code in the "UEFI diagnostic code" section of the Information Center for the appropriate user response.

**Related links**

– “Finding the UEFI diagnostic code” on page 776

- **806f000f-220107ff : The System [ComputerSystemElementName] encountered firmware error - unrecoverable keyboard failure.**

A System Firmware Error Unrecoverable Keyboard failure has occurred.

**Severity**

Error

**Serviceable**

Yes

**Automatically notify support**

No

**Alert Category**

Critical - Other

**SNMP Trap ID**

50

**CIM Information**

**Prefix:** PLAT ID: 0764

**User Response**

This is a UEFI detected event. The UEFI diagnostic code for this event can be found in the logged IMM message text. Please refer to the UEFI diagnostic code in the "UEFI diagnostic code" section of the Information Center for the appropriate user response.

**Related links**

- "Finding the UEFI diagnostic code" on page 776
- **806f000f-22010aff : The System [ComputerSystemElementName] encountered firmware error - no video device detected.**

A system firmware error No video device detected has occurred.

**Severity**

Error

**Serviceable**

Yes

**Automatically notify support**

No

**Alert Category**

Critical - Other

**SNMP Trap ID**

50

**CIM Information**

**Prefix:** PLAT ID: 0766

**User Response**

This is a UEFI detected event. The UEFI diagnostic code for this event can be found in the logged IMM message text. Please refer to the UEFI diagnostic code in the "UEFI diagnostic code" section of the Information Center for the appropriate user response.

**Related links**

- "Finding the UEFI diagnostic code" on page 776
- **806f000f-22010bff : Firmware BIOS (ROM) corruption was detected on system [ComputerSystemElementName] during POST.**

Firmware BIOS (ROM) corruption was detected on the system during POST. ABR Status. Firmware Error.

**Severity**

Error

**Serviceable**

Yes

**Automatically notify support**

No

**Alert Category**

Critical - Other

**SNMP Trap ID**

50

**CIM Information**

**Prefix:** PLAT ID: 0850

**User Response**

This is a UEFI detected event. The UEFI diagnostic code for this event can be found in the logged IMM message text. Please refer to the UEFI diagnostic code in the "UEFI diagnostic code" section of the Information Center for the appropriate user response.

**Related links**

- "Finding the UEFI diagnostic code" on page 776
- **806f000f-22010cff : CPU voltage mismatch detected on [ProcessorElementName].**

A CPU voltage mismatch with the socket voltage has been detected.

**Severity**

Error

**Serviceable**

Yes

**Automatically notify support**

No

**Alert Category**

Critical - CPU

**SNMP Trap ID**

40

**CIM Information**

**Prefix:** PLAT ID: 0050

**User Response**

This is a UEFI detected event. The UEFI diagnostic code for this event can be found in the logged IMM message text. Please refer to the UEFI diagnostic code in the "UEFI diagnostic code" section of the Information Center for the appropriate user response.

**Related links**

- "Finding the UEFI diagnostic code" on page 776
- **806f000f-2201ffff : The System [ComputerSystemElementName] encountered a POST Error.**

A Post Error has been detected.

**Severity**

Error

**Serviceable**

Yes

**Automatically notify support**

No

**Alert Category**

Critical - Other

**SNMP Trap ID**

50

**CIM Information**

**Prefix:** PLAT ID: 0184

**User Response**

This is a UEFI detected event. The UEFI diagnostic code for this event can be found in the logged IMM message text. Please refer to the UEFI diagnostic code in the "UEFI diagnostic code" section of the Information Center for the appropriate user response.

**Related links**

- "Finding the UEFI diagnostic code" on page 776



- **806f0013-1701ffff : A diagnostic interrupt has occurred on system [ComputerSystemElementName].**

The user has pressed the NMI button, or the NMI button has malfunctioned.

**Severity**

Error

**Serviceable**

Yes

**Automatically notify support**

No

**Alert Category**

Critical - Other

**SNMP Trap ID**

50

**CIM Information**

Prefix: PLAT ID: 0222

**User Response**

If the NMI button on the operator information panel has not been pressed, complete the following steps:

1. Make sure that the NMI button is not pressed.
2. Replace the system board.

- **806f001e-2201ffff : No bootable media available for system [ComputerSystemElementName].**

No boot device has been detected in the system.

**Severity**

Info

**Serviceable**

No

**Automatically notify support**

No

**Alert Category**

System - Other

**SNMP Trap ID**

**CIM Information**

Prefix: PLAT ID: 0286

**User Response**

Please install and configure a boot media, and attempt to power on and boot the server, again.

- **806f0021-2201ffff : Fault in slot [PhysicalConnectorSystemElementName] on system [ComputerSystemElementName].**

A fault in a slot has been detected. No Op ROM Space.

**Severity**

Error

**Serviceable**

Yes

**Automatically notify support**

Yes

**Alert Category**

Critical - Other

**SNMP Trap ID**

50

**CIM Information**

**Prefix:** PLAT ID: 0330

**User Response**

This is a UEFI detected event. The UEFI diagnostic code for this event can be found in the logged IMM message text. Please refer to the UEFI diagnostic code in the "UEFI diagnostic code" section of the Information Center for the appropriate user response.

**Related links**

– “Finding the UEFI diagnostic code” on page 776

- **806f0021-25820901 : Fault in slot [PhysicalConnectorSystemElementName] on system [ComputerSystemElementName].**

A fault in a slot has been detected. PCIe Error.

**Severity**

Error

**Serviceable**

Yes

**Automatically notify support**

Yes

**Alert Category**

Critical - Other

**SNMP Trap ID**

50

**CIM Information**

**Prefix:** PLAT ID: 0330

**User Response**

This is a UEFI detected event. The UEFI diagnostic code for this event can be found in the logged IMM message text. Please refer to the UEFI diagnostic code in the "UEFI diagnostic code" section of the Information Center for the appropriate user response.

**Related links**

– “Finding the UEFI diagnostic code” on page 776

- **806f0021-25820903 : Fault in slot [PhysicalConnectorSystemElementName] on system [ComputerSystemElementName].**

A fault in a slot has been detected, PCIe Error.

**Severity**

Error

**Serviceable**

Yes

**Automatically notify support**

Yes

**Alert Category**

Critical - Other

**SNMP Trap ID**

50

**CIM Information**

**Prefix:** PLAT ID: 0330

**User Response**

This is a UEFI detected event. The UEFI diagnostic code for this event can be found in the logged IMM message text. Please refer to the UEFI diagnostic code in the "UEFI diagnostic code" section of the Information Center for the appropriate user response.

**Related links**

- "Finding the UEFI diagnostic code" on page 776
- **806f0021-25820904 : Fault in slot [PhysicalConnectorSystemElementName] on system [ComputerSystemElementName].**

A fault in a slot has been detected, PCIe Error.

**Severity**

Error

**Serviceable**

Yes

**Automatically notify support**

Yes

**Alert Category**

Critical - Other

**SNMP Trap ID**

50

**CIM Information**

**Prefix:** PLAT ID: 0330

**User Response**

This is a UEFI detected event. The UEFI diagnostic code for this event can be found in the logged IMM message text. Please refer to the UEFI diagnostic code in the "UEFI diagnostic code" section of the Information Center for the appropriate user response.

**Related links**

- "Finding the UEFI diagnostic code" on page 776
- **806f0021-2582ffff : Fault in slot [PhysicalConnectorSystemElementName] on system [ComputerSystemElementName].**

A fault in a slot has been detected, PCIe Error.

**Severity**

Error

**Serviceable**

Yes

**Automatically notify support**

Yes

**Alert Category**

Critical - Other

**SNMP Trap ID**

50

**CIM Information**

Prefix: PLAT ID: 0330

**User Response**

This is a UEFI detected event. The UEFI diagnostic code for this event can be found in the logged IMM message text. Please refer to the UEFI diagnostic code in the "UEFI diagnostic code" section of the Information Center for the appropriate user response.

**Related links**

- "Finding the UEFI diagnostic code" on page 776
- **806f0023-2101ffff : Watchdog Timer expired for IPMI Watchdog.**  
The IPMI watchdog timer has expired.

**Severity**

Info

**Serviceable**

No

**Automatically notify support**

No

**Alert Category**

System - Other

**SNMP Trap ID****CIM Information**

Prefix: PLAT ID: 0368

**User Response**

Information only; no action is required.

- **806f0028-2101ffff : Sensor TPM Cmd Failures is unavailable or degraded on management system [ComputerSystemElementName].**  
TPM initialization or start up commands have failed.

**Severity**

Warning

**Serviceable**

Yes

**Automatically notify support**

No

**Alert Category**

Warning - Other

**SNMP Trap ID**

60

**CIM Information**

Prefix: PLAT ID: 0398

**User Response**

1. Reboot the system.
2. If error persists, or boot is unsuccessful, (Trained service technician only) Replace the system board..

- **806f0107-0301ffff : An over-temperature condition has been detected on [ProcessorElementName].**

The temperature of microprocessor 1 has exceeded the critical level, causing a hard shutdown of the compute node.

**Severity**

Error

**Serviceable**

Yes

**Automatically notify support**

No

**Alert Category**

Critical - Temperature

**SNMP Trap ID**

0

**CIM Information**

Prefix: PLAT ID: 0036

**User Response**

Complete the following steps until the problem is solved:

1. Check the Chassis Management Module or Flex System Manager event log for any fan- or cooling-related issues.
  2. Make sure that the airflow at the front and rear of the chassis is not obstructed and that fillers are in place and correctly installed.
  3. Make sure that the room temperature is within operating specifications.
  4. Make sure that the microprocessor 1 heat sink is securely installed.
  5. Make sure that the microprocessor 1 heat sink is installed correctly and the thermal material is correctly applied.
  6. Replace microprocessor 1.
- **806f0107-0302ffff : An over-temperature condition has been detected on [ProcessorElementName].**

The temperature of microprocessor 2 has exceeded the critical level, causing a hard shutdown of the compute node.

**Severity**

Error

**Serviceable**

Yes

**Automatically notify support**

No

**Alert Category**

Critical - Temperature

**SNMP Trap ID**

0

**CIM Information**

Prefix: PLAT ID: 0036

**User Response**

Complete the following steps until the problem is solved:

1. Check the Chassis Management Module or Flex System Manager event log for any fan- or cooling-related issues.
  2. Make sure that the airflow at the front and rear of the chassis is not obstructed and that fillers are in place and correctly installed.
  3. Make sure that the room temperature is within operating specifications.
  4. Make sure that the microprocessor heat sink is securely installed.
  5. Make sure that the microprocessor heat sink is installed correctly and the thermal material is correctly applied.
  6. Replace microprocessor 2.
- **806f0107-0303ffff : An over-temperature condition has been detected on [ProcessorElementName].**

The temperature of microprocessor 3 has exceeded the critical level, causing a hard shutdown of the compute node.

**Severity**

Error

**Serviceable**

Yes

**Automatically notify support**

No

**Alert Category**

Critical - Temperature

**SNMP Trap ID**

0

**CIM Information**

**Prefix: PLAT ID: 0036**

**User Response**

Complete the following steps until the problem is solved:

1. Check the Chassis Management Module or Flex System Manager event log for any fan- or cooling-related issues.
  2. Make sure that the airflow at the front and rear of the chassis is not obstructed and that fillers are in place and correctly installed.
  3. Make sure that the room temperature is within operating specifications.
  4. Make sure that the microprocessor heat sink is securely installed.
  5. Make sure that the microprocessor heat sink is installed correctly and the thermal material is correctly applied.
  6. Replace microprocessor 3.
- **806f0107-0304ffff : An over-temperature condition has been detected on [ProcessorElementName].**

The temperature of microprocessor 4 has exceeded the critical level, causing a hard shutdown of the compute node.

**Severity**

Error

**Serviceable**

Yes

**Automatically notify support**

No

**Alert Category**

Critical - Temperature

**SNMP Trap ID**

0

**CIM Information**

**Prefix:** PLAT ID: 0036

**User Response**

Complete the following steps until the problem is solved:

1. Check the Chassis Management Module or Flex System Manager event log for any fan- or cooling-related issues.
  2. Make sure that the airflow at the front and rear of the chassis is not obstructed and that fillers are in place and correctly installed.
  3. Make sure that the room temperature is within operating specifications.
  4. Make sure that the microprocessor heat sink is securely installed.
  5. Make sure that the microprocessor heat sink is installed correctly and the thermal material is correctly applied.
  6. Replace microprocessor 4.
- **806f0107-2584ffff : An over-temperature condition has been detected on [ProcessorElementName].**

The temperature of the specified microprocessor has risen above its specified threshold.

**Severity**

Error

**Serviceable**

Yes

**Automatically notify support**

No

**Alert Category**

Critical - Temperature

**SNMP Trap ID**

0

**CIM Information**

**Prefix:** PLAT ID: 0036

**User Response**

Complete the following steps until the problem is solved:

1. Check the Chassis Management Module or Flex System Manager event log for any fan- or cooling-related issues.
2. Make sure that the airflow at the front and rear of the chassis is not obstructed and that fillers are in place and correctly installed.
3. Make sure that the room temperature is within operating specifications.
4. Make sure that the heat sink for the specified microprocessor is securely installed.
5. Make sure that the heat sink for the specified microprocessor is installed correctly and the thermal material is correctly applied.

6. Replace the specified microprocessor.

- **806f0109-0701ffff : system board 1 has been Power Cycled.**

The compute node has been powered off and powered on.

**Severity**

Info

**Serviceable**

No

**Automatically notify support**

No

**Alert Category**

System - Other

**SNMP Trap ID**

**CIM Information**

Prefix: PLAT ID: 0108

**User Response**

Information only; no action is required.

- **806f010c-2001ffff : Uncorrectable error detected for [PhysicalMemoryElementName] on Subsystem [MemoryElementName].**

An uncorrectable memory error has been detected.

**Severity**

Error

**Serviceable**

Yes

**Automatically notify support**

Yes

**Alert Category**

Critical - Memory

**SNMP Trap ID**

41

**CIM Information**

Prefix: PLAT ID: 0138

**User Response**

This is a UEFI detected event. The UEFI diagnostic code for this event can be found in the logged IMM message text. Please refer to the UEFI diagnostic code in the "UEFI diagnostic code" section of the Information Center for the appropriate user response.

**Related links**

– “Finding the UEFI diagnostic code” on page 776

- **806f010c-2002ffff : Uncorrectable error detected for [PhysicalMemoryElementName] on Subsystem [MemoryElementName].**

An uncorrectable memory error has been detected.

**Severity**

Error

**Serviceable**



Yes

**Automatically notify support**

Yes

**Alert Category**

Critical - Memory

**SNMP Trap ID**

41

**CIM Information**

**Prefix:** PLAT ID: 0138

**User Response**

This is a UEFI detected event. The UEFI diagnostic code for this event can be found in the logged IMM message text. Please refer to the UEFI diagnostic code in the "UEFI diagnostic code" section of the Information Center for the appropriate user response.

**Related links**

- "Finding the UEFI diagnostic code" on page 776
- **806f010c-2003ffff : Uncorrectable error detected for [PhysicalMemoryElementName] on Subsystem [MemoryElementName].**

An uncorrectable memory error has been detected.

**Severity**

Error

**Serviceable**

Yes

**Automatically notify support**

Yes

**Alert Category**

Critical - Memory

**SNMP Trap ID**

41

**CIM Information**

**Prefix:** PLAT ID: 0138

**User Response**

This is a UEFI detected event. The UEFI diagnostic code for this event can be found in the logged IMM message text. Please refer to the UEFI diagnostic code in the "UEFI diagnostic code" section of the Information Center for the appropriate user response.

**Related links**

- "Finding the UEFI diagnostic code" on page 776
- **806f010c-2004ffff : Uncorrectable error detected for [PhysicalMemoryElementName] on Subsystem [MemoryElementName].**

An uncorrectable memory error has been detected.

**Severity**

Error

**Serviceable**

Yes

**Automatically notify support**

Yes

**Alert Category**

Critical - Memory

**SNMP Trap ID**

41

**CIM Information**

Prefix: PLAT ID: 0138

**User Response**

This is a UEFI detected event. The UEFI diagnostic code for this event can be found in the logged IMM message text. Please refer to the UEFI diagnostic code in the "UEFI diagnostic code" section of the Information Center for the appropriate user response.

**Related links**

- "Finding the UEFI diagnostic code" on page 776
- **806f010c-2005ffff : Uncorrectable error detected for [PhysicalMemoryElementName] on Subsystem [MemoryElementName].**

An uncorrectable memory error has been detected.

**Severity**

Error

**Serviceable**

Yes

**Automatically notify support**

Yes

**Alert Category**

Critical - Memory

**SNMP Trap ID**

41

**CIM Information**

Prefix: PLAT ID: 0138

**User Response**

This is a UEFI detected event. The UEFI diagnostic code for this event can be found in the logged IMM message text. Please refer to the UEFI diagnostic code in the "UEFI diagnostic code" section of the Information Center for the appropriate user response.

**Related links**

- "Finding the UEFI diagnostic code" on page 776
- **806f010c-2006ffff : Uncorrectable error detected for [PhysicalMemoryElementName] on Subsystem [MemoryElementName].**

An uncorrectable memory error has been detected.

**Severity**

Error

**Serviceable**

Yes

**Automatically notify support**

Yes

**Alert Category**

Critical - Memory

**SNMP Trap ID**

**CIM Information****Prefix:** PLAT ID: 0138**User Response**

This is a UEFI detected event. The UEFI diagnostic code for this event can be found in the logged IMM message text. Please refer to the UEFI diagnostic code in the "UEFI diagnostic code" section of the Information Center for the appropriate user response.

**Related links**

- "Finding the UEFI diagnostic code" on page 776
- **806f010c-2007ffff : Uncorrectable error detected for [PhysicalMemoryElementName] on Subsystem [MemoryElementName].**

An uncorrectable memory error has been detected.

**Severity**

Error

**Serviceable**

Yes

**Automatically notify support**

Yes

**Alert Category**

Critical - Memory

**SNMP Trap ID**

41

**CIM Information****Prefix:** PLAT ID: 0138**User Response**

This is a UEFI detected event. The UEFI diagnostic code for this event can be found in the logged IMM message text. Please refer to the UEFI diagnostic code in the "UEFI diagnostic code" section of the Information Center for the appropriate user response.

**Related links**

- "Finding the UEFI diagnostic code" on page 776
- **806f010c-2008ffff : Uncorrectable error detected for [PhysicalMemoryElementName] on Subsystem [MemoryElementName].**

An uncorrectable memory error has been detected.

**Severity**

Error

**Serviceable**

Yes

**Automatically notify support**

Yes

**Alert Category**

Critical - Memory

**SNMP Trap ID**

41

**CIM Information****Prefix:** PLAT ID: 0138

**User Response**

This is a UEFI detected event. The UEFI diagnostic code for this event can be found in the logged IMM message text. Please refer to the UEFI diagnostic code in the "UEFI diagnostic code" section of the Information Center for the appropriate user response.

**Related links**

– “Finding the UEFI diagnostic code” on page 776

- **806f010c-2009ffff : Uncorrectable error detected for [PhysicalMemoryElementName] on Subsystem [MemoryElementName].**

An uncorrectable memory error has been detected.

**Severity**

Error

**Serviceable**

Yes

**Automatically notify support**

Yes

**Alert Category**

Critical - Memory

**SNMP Trap ID**

41

**CIM Information**

Prefix: PLAT ID: 0138

**User Response**

This is a UEFI detected event. The UEFI diagnostic code for this event can be found in the logged IMM message text. Please refer to the UEFI diagnostic code in the "UEFI diagnostic code" section of the Information Center for the appropriate user response.

**Related links**

– “Finding the UEFI diagnostic code” on page 776

- **806f010c-200affff : Uncorrectable error detected for [PhysicalMemoryElementName] on Subsystem [MemoryElementName].**

An uncorrectable memory error has been detected.

**Severity**

Error

**Serviceable**

Yes

**Automatically notify support**

Yes

**Alert Category**

Critical - Memory

**SNMP Trap ID**

41

**CIM Information**

Prefix: PLAT ID: 0138

**User Response**

This is a UEFI detected event. The UEFI diagnostic code for this event can be found in the logged IMM message text. Please refer to the UEFI diagnostic code in the "UEFI diagnostic code" section of the Information Center for the appropriate user response.

**Related links**

– “Finding the UEFI diagnostic code” on page 776

- **806f010c-200bffff : Uncorrectable error detected for [PhysicalMemoryElementName] on Subsystem [MemoryElementName].**

An uncorrectable memory error has been detected.

**Severity**

Error

**Serviceable**

Yes

**Automatically notify support**

Yes

**Alert Category**

Critical - Memory

**SNMP Trap ID**

41

**CIM Information**

**Prefix:** PLAT ID: 0138

**User Response**

This is a UEFI detected event. The UEFI diagnostic code for this event can be found in the logged IMM message text. Please refer to the UEFI diagnostic code in the "UEFI diagnostic code" section of the Information Center for the appropriate user response.

**Related links**

– “Finding the UEFI diagnostic code” on page 776

- **806f010c-200cffff : Uncorrectable error detected for [PhysicalMemoryElementName] on Subsystem [MemoryElementName].**

An uncorrectable memory error has been detected.

**Severity**

Error

**Serviceable**

Yes

**Automatically notify support**

Yes

**Alert Category**

Critical - Memory

**SNMP Trap ID**

41

**CIM Information**

**Prefix:** PLAT ID: 0138

**User Response**

This is a UEFI detected event. The UEFI diagnostic code for this event can be found in the logged IMM message text. Please refer to the UEFI diagnostic code in the "UEFI diagnostic code" section of the Information Center for the appropriate user response.

**Related links**

– “Finding the UEFI diagnostic code” on page 776

- **806f010c-200dffff : Uncorrectable error detected for [PhysicalMemoryElementName] on Subsystem [MemoryElementName].**

An uncorrectable memory error has been detected.

**Severity**

Error

**Serviceable**

Yes

**Automatically notify support**

Yes

**Alert Category**

Critical - Memory

**SNMP Trap ID**

41

**CIM Information**

Prefix: PLAT ID: 0138

**User Response**

This is a UEFI detected event. The UEFI diagnostic code for this event can be found in the logged IMM message text. Please refer to the UEFI diagnostic code in the "UEFI diagnostic code" section of the Information Center for the appropriate user response.

**Related links**

– “Finding the UEFI diagnostic code” on page 776

- **806f010c-200effff : Uncorrectable error detected for [PhysicalMemoryElementName] on Subsystem [MemoryElementName].**

An uncorrectable memory error has been detected.

**Severity**

Error

**Serviceable**

Yes

**Automatically notify support**

Yes

**Alert Category**

Critical - Memory

**SNMP Trap ID**

41

**CIM Information**

Prefix: PLAT ID: 0138

**User Response**

This is a UEFI detected event. The UEFI diagnostic code for this event can be found in the logged IMM message text. Please refer to the UEFI diagnostic code in the "UEFI diagnostic code" section of the Information Center for the appropriate user response.

**Related links**

– “Finding the UEFI diagnostic code” on page 776

- **806f010c-200ffff : Uncorrectable error detected for [PhysicalMemoryElementName] on Subsystem [MemoryElementName].**

An uncorrectable memory error has been detected.

**Severity**

Error

**Serviceable**

Yes

**Automatically notify support**

Yes

**Alert Category**

Critical - Memory

**SNMP Trap ID**

41

**CIM Information**

Prefix: PLAT ID: 0138

**User Response**

This is a UEFI detected event. The UEFI diagnostic code for this event can be found in the logged IMM message text. Please refer to the UEFI diagnostic code in the "UEFI diagnostic code" section of the Information Center for the appropriate user response.

**Related links**

- "Finding the UEFI diagnostic code" on page 776

- **806f010c-2010ffff : Uncorrectable error detected for [PhysicalMemoryElementName] on Subsystem [MemoryElementName].**

An uncorrectable memory error has been detected.

**Severity**

Error

**Serviceable**

Yes

**Automatically notify support**

Yes

**Alert Category**

Critical - Memory

**SNMP Trap ID**

41

**CIM Information**

Prefix: PLAT ID: 0138

**User Response**

This is a UEFI detected event. The UEFI diagnostic code for this event can be found in the logged IMM message text. Please refer to the UEFI diagnostic code in the "UEFI diagnostic code" section of the Information Center for the appropriate user response.

**Related links**

- "Finding the UEFI diagnostic code" on page 776

- **806f010c-2011ffff : Uncorrectable error detected for [PhysicalMemoryElementName] on Subsystem [MemoryElementName].**

An uncorrectable memory error has been detected.

**Severity**

Error

**Serviceable**

Yes

**Automatically notify support**

Yes

**Alert Category**

Critical - Memory

**SNMP Trap ID**

41

**CIM Information**

**Prefix:** PLAT ID: 0138

**User Response**

This is a UEFI detected event. The UEFI diagnostic code for this event can be found in the logged IMM message text. Please refer to the UEFI diagnostic code in the "UEFI diagnostic code" section of the Information Center for the appropriate user response.

**Related links**

– “Finding the UEFI diagnostic code” on page 776

- **806f010c-2012ffff : Uncorrectable error detected for [PhysicalMemoryElementName] on Subsystem [MemoryElementName].**

An uncorrectable memory error has been detected.

**Severity**

Error

**Serviceable**

Yes

**Automatically notify support**

Yes

**Alert Category**

Critical - Memory

**SNMP Trap ID**

41

**CIM Information**

**Prefix:** PLAT ID: 0138

**User Response**

This is a UEFI detected event. The UEFI diagnostic code for this event can be found in the logged IMM message text. Please refer to the UEFI diagnostic code in the "UEFI diagnostic code" section of the Information Center for the appropriate user response.

**Related links**

– “Finding the UEFI diagnostic code” on page 776

- **806f010c-2013ffff : Uncorrectable error detected for [PhysicalMemoryElementName] on Subsystem [MemoryElementName].**

An uncorrectable memory error has been detected.

**Severity**

Error

**Serviceable**



Yes

**Automatically notify support**

Yes

**Alert Category**

Critical - Memory

**SNMP Trap ID**

41

**CIM Information**

**Prefix:** PLAT ID: 0138

**User Response**

This is a UEFI detected event. The UEFI diagnostic code for this event can be found in the logged IMM message text. Please refer to the UEFI diagnostic code in the "UEFI diagnostic code" section of the Information Center for the appropriate user response.

**Related links**

- "Finding the UEFI diagnostic code" on page 776
- **806f010c-2014ffff : Uncorrectable error detected for [PhysicalMemoryElementName] on Subsystem [MemoryElementName].**

An uncorrectable memory error has been detected.

**Severity**

Error

**Serviceable**

Yes

**Automatically notify support**

Yes

**Alert Category**

Critical - Memory

**SNMP Trap ID**

41

**CIM Information**

**Prefix:** PLAT ID: 0138

**User Response**

This is a UEFI detected event. The UEFI diagnostic code for this event can be found in the logged IMM message text. Please refer to the UEFI diagnostic code in the "UEFI diagnostic code" section of the Information Center for the appropriate user response.

**Related links**

- "Finding the UEFI diagnostic code" on page 776
- **806f010c-2015ffff : Uncorrectable error detected for [PhysicalMemoryElementName] on Subsystem [MemoryElementName].**

An uncorrectable memory error has been detected.

**Severity**

Error

**Serviceable**

Yes

**Automatically notify support**

Yes

**Alert Category**

Critical - Memory

**SNMP Trap ID**

41

**CIM Information**

Prefix: PLAT ID: 0138

**User Response**

This is a UEFI detected event. The UEFI diagnostic code for this event can be found in the logged IMM message text. Please refer to the UEFI diagnostic code in the "UEFI diagnostic code" section of the Information Center for the appropriate user response.

**Related links**

– "Finding the UEFI diagnostic code" on page 776

- **806f010c-2016ffff : Uncorrectable error detected for [PhysicalMemoryElementName] on Subsystem [MemoryElementName].**

An uncorrectable memory error has been detected.

**Severity**

Error

**Serviceable**

Yes

**Automatically notify support**

Yes

**Alert Category**

Critical - Memory

**SNMP Trap ID**

41

**CIM Information**

Prefix: PLAT ID: 0138

**User Response**

This is a UEFI detected event. The UEFI diagnostic code for this event can be found in the logged IMM message text. Please refer to the UEFI diagnostic code in the "UEFI diagnostic code" section of the Information Center for the appropriate user response.

**Related links**

– "Finding the UEFI diagnostic code" on page 776

- **806f010c-2017ffff : Uncorrectable error detected for [PhysicalMemoryElementName] on Subsystem [MemoryElementName].**

An uncorrectable memory error has been detected.

**Severity**

Error

**Serviceable**

Yes

**Automatically notify support**

Yes

**Alert Category**

Critical - Memory

**SNMP Trap ID**

**CIM Information****Prefix:** PLAT ID: 0138**User Response**

This is a UEFI detected event. The UEFI diagnostic code for this event can be found in the logged IMM message text. Please refer to the UEFI diagnostic code in the "UEFI diagnostic code" section of the Information Center for the appropriate user response.

**Related links**

- "Finding the UEFI diagnostic code" on page 776
- **806f010c-2018ffff : Uncorrectable error detected for [PhysicalMemoryElementName] on Subsystem [MemoryElementName].**

An uncorrectable memory error has been detected.

**Severity**

Error

**Serviceable**

Yes

**Automatically notify support**

Yes

**Alert Category**

Critical - Memory

**SNMP Trap ID**

41

**CIM Information****Prefix:** PLAT ID: 0138**User Response**

This is a UEFI detected event. The UEFI diagnostic code for this event can be found in the logged IMM message text. Please refer to the UEFI diagnostic code in the "UEFI diagnostic code" section of the Information Center for the appropriate user response.

**Related links**

- "Finding the UEFI diagnostic code" on page 776
- **806f010c-2019ffff : Uncorrectable error detected for [PhysicalMemoryElementName] on Subsystem [MemoryElementName].**

An uncorrectable memory error has been detected.

**Severity**

Error

**Serviceable**

Yes

**Automatically notify support**

Yes

**Alert Category**

Critical - Memory

**SNMP Trap ID**

41

**CIM Information****Prefix:** PLAT ID: 0138

**User Response**

This is a UEFI detected event. The UEFI diagnostic code for this event can be found in the logged IMM message text. Please refer to the UEFI diagnostic code in the "UEFI diagnostic code" section of the Information Center for the appropriate user response.

**Related links**

– “Finding the UEFI diagnostic code” on page 776

- **806f010c-201affff : Uncorrectable error detected for [PhysicalMemoryElementName] on Subsystem [MemoryElementName].**

An uncorrectable memory error has been detected.

**Severity**

Error

**Serviceable**

Yes

**Automatically notify support**

Yes

**Alert Category**

Critical - Memory

**SNMP Trap ID**

41

**CIM Information**

Prefix: PLAT ID: 0138

**User Response**

This is a UEFI detected event. The UEFI diagnostic code for this event can be found in the logged IMM message text. Please refer to the UEFI diagnostic code in the "UEFI diagnostic code" section of the Information Center for the appropriate user response.

**Related links**

– “Finding the UEFI diagnostic code” on page 776

- **806f010c-201bffff : Uncorrectable error detected for [PhysicalMemoryElementName] on Subsystem [MemoryElementName].**

An uncorrectable memory error has been detected.

**Severity**

Error

**Serviceable**

Yes

**Automatically notify support**

Yes

**Alert Category**

Critical - Memory

**SNMP Trap ID**

41

**CIM Information**

Prefix: PLAT ID: 0138

**User Response**

This is a UEFI detected event. The UEFI diagnostic code for this event can be found in the logged IMM message text. Please refer to the UEFI diagnostic code in the "UEFI diagnostic code" section of the Information Center for the appropriate user response.

**Related links**

– “Finding the UEFI diagnostic code” on page 776

- **806f010c-201c01ff : Uncorrectable error detected for [PhysicalMemoryElementName] on Subsystem [MemoryElementName].**

An uncorrectable memory error has been detected.

**Severity**

Error

**Serviceable**

Yes

**Automatically notify support**

Yes

**Alert Category**

Critical - Memory

**SNMP Trap ID**

41

**CIM Information**

**Prefix:** PLAT ID: 0138

**User Response**

This is a UEFI detected event. The UEFI diagnostic code for this event can be found in the logged IMM message text. Please refer to the UEFI diagnostic code in the "UEFI diagnostic code" section of the Information Center for the appropriate user response.

**Related links**

– “Finding the UEFI diagnostic code” on page 776

- **806f010c-201cffff : Uncorrectable error detected for [PhysicalMemoryElementName] on Subsystem [MemoryElementName].**

An uncorrectable memory error has been detected.

**Severity**

Error

**Serviceable**

Yes

**Automatically notify support**

Yes

**Alert Category**

Critical - Memory

**SNMP Trap ID**

41

**CIM Information**

**Prefix:** PLAT ID: 0138

**User Response**

This is a UEFI detected event. The UEFI diagnostic code for this event can be found in the logged IMM message text. Please refer to the UEFI diagnostic code in the "UEFI diagnostic code" section of the Information Center for the appropriate user response.

**Related links**

– “Finding the UEFI diagnostic code” on page 776

- **806f010c-201dffff : Uncorrectable error detected for [PhysicalMemoryElementName] on Subsystem [MemoryElementName].**

An uncorrectable memory error has been detected.

**Severity**

Error

**Serviceable**

Yes

**Automatically notify support**

Yes

**Alert Category**

Critical - Memory

**SNMP Trap ID**

41

**CIM Information**

Prefix: PLAT ID: 0138

**User Response**

This is a UEFI detected event. The UEFI diagnostic code for this event can be found in the logged IMM message text. Please refer to the UEFI diagnostic code in the "UEFI diagnostic code" section of the Information Center for the appropriate user response.

**Related links**

– “Finding the UEFI diagnostic code” on page 776

- **806f010c-201effff : Uncorrectable error detected for [PhysicalMemoryElementName] on Subsystem [MemoryElementName].**

An uncorrectable memory error has been detected.

**Severity**

Error

**Serviceable**

Yes

**Automatically notify support**

Yes

**Alert Category**

Critical - Memory

**SNMP Trap ID**

41

**CIM Information**

Prefix: PLAT ID: 0138

**User Response**

This is a UEFI detected event. The UEFI diagnostic code for this event can be found in the logged IMM message text. Please refer to the UEFI diagnostic code in the "UEFI diagnostic code" section of the Information Center for the appropriate user response.

**Related links**

– “Finding the UEFI diagnostic code” on page 776

- **806f010c-201ffff : Uncorrectable error detected for [PhysicalMemoryElementName] on Subsystem [MemoryElementName].**

An uncorrectable memory error has been detected.

**Severity**

Error

**Serviceable**

Yes

**Automatically notify support**

Yes

**Alert Category**

Critical - Memory

**SNMP Trap ID**

41

**CIM Information**

Prefix: PLAT ID: 0138

**User Response**

This is a UEFI detected event. The UEFI diagnostic code for this event can be found in the logged IMM message text. Please refer to the UEFI diagnostic code in the "UEFI diagnostic code" section of the Information Center for the appropriate user response.

**Related links**

– “Finding the UEFI diagnostic code” on page 776

- **806f010c-2020ffff : Uncorrectable error detected for [PhysicalMemoryElementName] on Subsystem [MemoryElementName].**

An uncorrectable memory error has been detected.

**Severity**

Error

**Serviceable**

Yes

**Automatically notify support**

Yes

**Alert Category**

Critical - Memory

**SNMP Trap ID**

41

**CIM Information**

Prefix: PLAT ID: 0138

**User Response**

This is a UEFI detected event. The UEFI diagnostic code for this event can be found in the logged IMM message text. Please refer to the UEFI diagnostic code in the "UEFI diagnostic code" section of the Information Center for the appropriate user response.

**Related links**

– “Finding the UEFI diagnostic code” on page 776

- **806f010c-2021ffff : Uncorrectable error detected for [PhysicalMemoryElementName] on Subsystem [MemoryElementName].**

An uncorrectable memory error has been detected.

**Severity**

Error

**Serviceable**

Yes

**Automatically notify support**

Yes

**Alert Category**

Critical - Memory

**SNMP Trap ID**

41

**CIM Information**

**Prefix:** PLAT ID: 0138

**User Response**

This is a UEFI detected event. The UEFI diagnostic code for this event can be found in the logged IMM message text. Please refer to the UEFI diagnostic code in the "UEFI diagnostic code" section of the Information Center for the appropriate user response.

**Related links**

– “Finding the UEFI diagnostic code” on page 776

- **806f010c-2022ffff : Uncorrectable error detected for [PhysicalMemoryElementName] on Subsystem [MemoryElementName].**

An uncorrectable memory error has been detected.

**Severity**

Error

**Serviceable**

Yes

**Automatically notify support**

Yes

**Alert Category**

Critical - Memory

**SNMP Trap ID**

41

**CIM Information**

**Prefix:** PLAT ID: 0138

**User Response**

This is a UEFI detected event. The UEFI diagnostic code for this event can be found in the logged IMM message text. Please refer to the UEFI diagnostic code in the "UEFI diagnostic code" section of the Information Center for the appropriate user response.

**Related links**

– “Finding the UEFI diagnostic code” on page 776

- **806f010c-2023ffff : Uncorrectable error detected for [PhysicalMemoryElementName] on Subsystem [MemoryElementName].**

An uncorrectable memory error has been detected.

**Severity**

Error

**Serviceable**



Yes

**Automatically notify support**

Yes

**Alert Category**

Critical - Memory

**SNMP Trap ID**

41

**CIM Information**

**Prefix:** PLAT ID: 0138

**User Response**

This is a UEFI detected event. The UEFI diagnostic code for this event can be found in the logged IMM message text. Please refer to the UEFI diagnostic code in the "UEFI diagnostic code" section of the Information Center for the appropriate user response.

**Related links**

- "Finding the UEFI diagnostic code" on page 776
- **806f010c-2024ffff : Uncorrectable error detected for [PhysicalMemoryElementName] on Subsystem [MemoryElementName].**

An uncorrectable memory error has been detected.

**Severity**

Error

**Serviceable**

Yes

**Automatically notify support**

Yes

**Alert Category**

Critical - Memory

**SNMP Trap ID**

41

**CIM Information**

**Prefix:** PLAT ID: 0138

**User Response**

This is a UEFI detected event. The UEFI diagnostic code for this event can be found in the logged IMM message text. Please refer to the UEFI diagnostic code in the "UEFI diagnostic code" section of the Information Center for the appropriate user response.

**Related links**

- "Finding the UEFI diagnostic code" on page 776
- **806f010c-2025ffff : Uncorrectable error detected for [PhysicalMemoryElementName] on Subsystem [MemoryElementName].**

An uncorrectable memory error has been detected.

**Severity**

Error

**Serviceable**

Yes

**Automatically notify support**

Yes

**Alert Category**

Critical - Memory

**SNMP Trap ID**

41

**CIM Information**

Prefix: PLAT ID: 0138

**User Response**

This is a UEFI detected event. The UEFI diagnostic code for this event can be found in the logged IMM message text. Please refer to the UEFI diagnostic code in the "UEFI diagnostic code" section of the Information Center for the appropriate user response.

**Related links**

– "Finding the UEFI diagnostic code" on page 776

- **806f010c-2026ffff : Uncorrectable error detected for [PhysicalMemoryElementName] on Subsystem [MemoryElementName].**

An uncorrectable memory error has been detected.

**Severity**

Error

**Serviceable**

Yes

**Automatically notify support**

Yes

**Alert Category**

Critical - Memory

**SNMP Trap ID**

41

**CIM Information**

Prefix: PLAT ID: 0138

**User Response**

This is a UEFI detected event. The UEFI diagnostic code for this event can be found in the logged IMM message text. Please refer to the UEFI diagnostic code in the "UEFI diagnostic code" section of the Information Center for the appropriate user response.

**Related links**

– "Finding the UEFI diagnostic code" on page 776

- **806f010c-2027ffff : Uncorrectable error detected for [PhysicalMemoryElementName] on Subsystem [MemoryElementName].**

An uncorrectable memory error has been detected.

**Severity**

Error

**Serviceable**

Yes

**Automatically notify support**

Yes

**Alert Category**

Critical - Memory

**SNMP Trap ID**

**CIM Information****Prefix:** PLAT ID: 0138**User Response**

This is a UEFI detected event. The UEFI diagnostic code for this event can be found in the logged IMM message text. Please refer to the UEFI diagnostic code in the "UEFI diagnostic code" section of the Information Center for the appropriate user response.

**Related links**

- "Finding the UEFI diagnostic code" on page 776
- **806f010c-202802ff : Uncorrectable error detected for [PhysicalMemoryElementName] on Subsystem [MemoryElementName].**

An uncorrectable memory error has been detected.

**Severity**

Error

**Serviceable**

Yes

**Automatically notify support**

Yes

**Alert Category**

Critical - Memory

**SNMP Trap ID**

41

**CIM Information****Prefix:** PLAT ID: 0138**User Response**

This is a UEFI detected event. The UEFI diagnostic code for this event can be found in the logged IMM message text. Please refer to the UEFI diagnostic code in the "UEFI diagnostic code" section of the Information Center for the appropriate user response.

**Related links**

- "Finding the UEFI diagnostic code" on page 776
- **806f010c-2028ffff : Uncorrectable error detected for [PhysicalMemoryElementName] on Subsystem [MemoryElementName].**

An uncorrectable memory error has been detected.

**Severity**

Error

**Serviceable**

Yes

**Automatically notify support**

Yes

**Alert Category**

Critical - Memory

**SNMP Trap ID**

41

**CIM Information****Prefix:** PLAT ID: 0138

**User Response**

This is a UEFI detected event. The UEFI diagnostic code for this event can be found in the logged IMM message text. Please refer to the UEFI diagnostic code in the "UEFI diagnostic code" section of the Information Center for the appropriate user response.

**Related links**

– “Finding the UEFI diagnostic code” on page 776

- **806f010c-2029ffff : Uncorrectable error detected for [PhysicalMemoryElementName] on Subsystem [MemoryElementName].**

An uncorrectable memory error has been detected.

**Severity**

Error

**Serviceable**

Yes

**Automatically notify support**

Yes

**Alert Category**

Critical - Memory

**SNMP Trap ID**

41

**CIM Information**

Prefix: PLAT ID: 0138

**User Response**

This is a UEFI detected event. The UEFI diagnostic code for this event can be found in the logged IMM message text. Please refer to the UEFI diagnostic code in the "UEFI diagnostic code" section of the Information Center for the appropriate user response.

**Related links**

– “Finding the UEFI diagnostic code” on page 776

- **806f010c-202affff : Uncorrectable error detected for [PhysicalMemoryElementName] on Subsystem [MemoryElementName].**

An uncorrectable memory error has been detected.

**Severity**

Error

**Serviceable**

Yes

**Automatically notify support**

Yes

**Alert Category**

Critical - Memory

**SNMP Trap ID**

41

**CIM Information**

Prefix: PLAT ID: 0138

**User Response**

This is a UEFI detected event. The UEFI diagnostic code for this event can be found in the logged IMM message text. Please refer to the UEFI diagnostic code in the "UEFI diagnostic code" section of the Information Center for the appropriate user response.

**Related links**

- "Finding the UEFI diagnostic code" on page 776
- **806f010c-202bffff : Uncorrectable error detected for [PhysicalMemoryElementName] on Subsystem [MemoryElementName].**

An uncorrectable memory error has been detected.

**Severity**

Error

**Serviceable**

Yes

**Automatically notify support**

Yes

**Alert Category**

Critical - Memory

**SNMP Trap ID**

41

**CIM Information**

**Prefix:** PLAT ID: 0138

**User Response**

This is a UEFI detected event. The UEFI diagnostic code for this event can be found in the logged IMM message text. Please refer to the UEFI diagnostic code in the "UEFI diagnostic code" section of the Information Center for the appropriate user response.

**Related links**

- "Finding the UEFI diagnostic code" on page 776
- **806f010c-202cffff : Uncorrectable error detected for [PhysicalMemoryElementName] on Subsystem [MemoryElementName].**

An uncorrectable memory error has been detected.

**Severity**

Error

**Serviceable**

Yes

**Automatically notify support**

Yes

**Alert Category**

Critical - Memory

**SNMP Trap ID**

41

**CIM Information**

**Prefix:** PLAT ID: 0138

**User Response**

This is a UEFI detected event. The UEFI diagnostic code for this event can be found in the logged IMM message text. Please refer to the UEFI diagnostic code in the "UEFI diagnostic code" section of the Information Center for the appropriate user response.

**Related links**

– “Finding the UEFI diagnostic code” on page 776

- **806f010c-202dffff : Uncorrectable error detected for [PhysicalMemoryElementName] on Subsystem [MemoryElementName].**

An uncorrectable memory error has been detected.

**Severity**

Error

**Serviceable**

Yes

**Automatically notify support**

Yes

**Alert Category**

Critical - Memory

**SNMP Trap ID**

41

**CIM Information**

Prefix: PLAT ID: 0138

**User Response**

This is a UEFI detected event. The UEFI diagnostic code for this event can be found in the logged IMM message text. Please refer to the UEFI diagnostic code in the "UEFI diagnostic code" section of the Information Center for the appropriate user response.

**Related links**

– “Finding the UEFI diagnostic code” on page 776

- **806f010c-202effff : Uncorrectable error detected for [PhysicalMemoryElementName] on Subsystem [MemoryElementName].**

An uncorrectable memory error has been detected.

**Severity**

Error

**Serviceable**

Yes

**Automatically notify support**

Yes

**Alert Category**

Critical - Memory

**SNMP Trap ID**

41

**CIM Information**

Prefix: PLAT ID: 0138

**User Response**

This is a UEFI detected event. The UEFI diagnostic code for this event can be found in the logged IMM message text. Please refer to the UEFI diagnostic code in the "UEFI diagnostic code" section of the Information Center for the appropriate user response.

**Related links**

– “Finding the UEFI diagnostic code” on page 776

- **806f010c-202ffff : Uncorrectable error detected for [PhysicalMemoryElementName] on Subsystem [MemoryElementName].**

An uncorrectable memory error has been detected.

**Severity**

Error

**Serviceable**

Yes

**Automatically notify support**

Yes

**Alert Category**

Critical - Memory

**SNMP Trap ID**

41

**CIM Information**

Prefix: PLAT ID: 0138

**User Response**

This is a UEFI detected event. The UEFI diagnostic code for this event can be found in the logged IMM message text. Please refer to the UEFI diagnostic code in the "UEFI diagnostic code" section of the Information Center for the appropriate user response.

**Related links**

- "Finding the UEFI diagnostic code" on page 776

- **806f010c-2030ffff : Uncorrectable error detected for [PhysicalMemoryElementName] on Subsystem [MemoryElementName].**

An uncorrectable memory error has been detected.

**Severity**

Error

**Serviceable**

Yes

**Automatically notify support**

Yes

**Alert Category**

Critical - Memory

**SNMP Trap ID**

41

**CIM Information**

Prefix: PLAT ID: 0138

**User Response**

This is a UEFI detected event. The UEFI diagnostic code for this event can be found in the logged IMM message text. Please refer to the UEFI diagnostic code in the "UEFI diagnostic code" section of the Information Center for the appropriate user response.

**Related links**

- "Finding the UEFI diagnostic code" on page 776

- **806f010c-2581ffff : Uncorrectable error detected for [PhysicalMemoryElementName] on Subsystem [MemoryElementName].**

A memory uncorrectable error has been detected. All DIMMs. One of the DIMMs.

**Severity**

Error

**Serviceable**

Yes

**Automatically notify support**

Yes

**Alert Category**

Critical - Memory

**SNMP Trap ID**

41

**CIM Information****Prefix: PLAT ID:** 0138**User Response**

This is a UEFI detected event. The UEFI diagnostic code for this event can be found in the logged IMM message text. Please refer to the UEFI diagnostic code in the "UEFI diagnostic code" section of the Information Center for the appropriate user response.

**Related links**

– “Finding the UEFI diagnostic code” on page 776

- **806f010d-0400ffff : The Drive Drive 0 has been disabled due to a detected fault.**

The hard disk drive controller has detected a fault in hard disk drive 0. Hard disk drive 0 is now defunct.

**Severity**

Error

**Serviceable**

Yes

**Automatically notify support**

Yes

**Alert Category**

Critical - Hard Disk drive

**SNMP Trap ID**

5

**CIM Information****Prefix: PLAT ID:** 0164**User Response**

Complete the following steps until the problem is solved:

1. Check the Support Portal for service bulletins and RETAIN tips related to your drive.
2. Check the Support Portal for firmware updates related to your drive.
3. Replace the drive.
4. Check for any other RAID-related errors.

- **806f010d-0401ffff : The Drive Drive 1 has been disabled due to a detected fault.**

The hard disk drive controller has detected a fault in hard disk drive 1. Hard disk drive 1 is now defunct.

**Severity**

Error

**Serviceable**

Yes



**Automatically notify support**

Yes

**Alert Category**

Critical - Hard Disk drive

**SNMP Trap ID**

5

**CIM Information**

**Prefix:** PLAT ID: 0164

**User Response**

Complete the following steps until the problem is solved:

1. Check the Support Portal for service bulletins and RETAIN tips related to your drive.
2. Check the Support Portal for firmware updates related to your drive.
3. Replace the drive.
4. Check for any other RAID-related errors.

- **806f010d-0402ffff : The Drive Drive 2 has been disabled due to a detected fault.**

The hard disk drive controller has detected a fault in hard disk drive 2. Hard disk drive 2 is now defunct.

**Severity**

Error

**Serviceable**

Yes

**Automatically notify support**

Yes

**Alert Category**

Critical - Hard Disk drive

**SNMP Trap ID**

5

**CIM Information**

**Prefix:** PLAT ID: 0164

**User Response**

Complete the following steps until the problem is solved:

1. Check the Support Portal for service bulletins and RETAIN tips related to your drive.
2. Check the Support Portal for firmware updates related to your drive.
3. Replace the drive.
4. Check for any other RAID related errors.

- **806f010d-0403ffff : The Drive Drive 3 has been disabled due to a detected fault.**

The hard disk drive controller has detected a fault in hard disk drive 3. Hard disk drive 3 is now defunct.

**Severity**

Error

**Serviceable**

Yes

**Automatically notify support**

Yes

**Alert Category**

Critical - Hard Disk drive

**SNMP Trap ID**

5

**CIM Information**

**Prefix: PLAT ID:** 0164

**User Response**

Complete the following steps until the problem is solved:

1. Check the Support Portal for service bulletins and RETAIN tips related to your drive.
2. Check the Support Portal for firmware updates related to your drive.
3. Replace the drive.
4. Check for any other RAID-related errors.

- **806f010d-0404ffff : The Drive Drive 4 has been disabled due to a detected fault.**

The hard disk drive controller has detected a fault in hard disk drive 4. Hard disk drive 4 is now defunct.

**Severity**

Error

**Serviceable**

Yes

**Automatically notify support**

Yes

**Alert Category**

Critical - Hard Disk drive

**SNMP Trap ID**

5

**CIM Information**

**Prefix: PLAT ID:** 0164

**User Response**

Complete the following steps until the problem is solved:

1. Check the Support Portal for service bulletins and RETAIN tips related to your drive.
2. Check the Support Portal for firmware updates related to your drive.
3. Replace the drive.
4. Check for any other RAID-related errors.

- **806f010d-0405ffff : The Drive Drive 5 has been disabled due to a detected fault.**

The hard disk drive controller has detected a fault in hard disk drive 5. Hard disk drive 5 is now defunct.

**Severity**

Error

**Serviceable**

Yes

**Automatically notify support**

Yes

**Alert Category**

Critical - Hard Disk drive

**SNMP Trap ID**

5

**CIM Information**

Prefix: PLAT ID: 0164

**User Response**

Complete the following steps until the problem is solved:

1. Check the Support Portal for service bulletins and RETAIN tips related to your drive.
2. Check the Support Portal for firmware updates related to your drive.
3. Replace the drive.
4. Check for any other RAID-related errors.

- **806f010d-0406ffff : The Drive Drive 6 has been disabled due to a detected fault.**

The hard disk drive controller has detected a fault in hard disk drive 6. Hard disk drive 6 is now defunct.

**Severity**

Error

**Serviceable**

Yes

**Automatically notify support**

Yes

**Alert Category**

Critical - Hard Disk drive

**SNMP Trap ID**

5

**CIM Information**

Prefix: PLAT ID: 0164

**User Response**

Complete the following steps until the problem is solved:

1. Check the Support Portal for service bulletins and RETAIN tips related to your drive.
2. Check the Support Portal for firmware updates related to your drive.
3. Replace the drive.
4. Check for any other RAID-related errors.

- **806f010d-0407ffff : The Drive Drive 7 has been disabled due to a detected fault.**

The hard disk drive controller has detected a fault in hard disk drive 7. Hard disk drive 7 is now defunct.

**Severity**

Error

**Serviceable**

Yes

**Automatically notify support**

Yes

**Alert Category**

Critical - Hard Disk drive

**SNMP Trap ID**

5

**CIM Information**

Prefix: PLAT ID: 0164

**User Response**

Complete the following steps until the problem is solved:

1. Check the Support Portal for service bulletins and RETAIN tips related to your drive.
  2. Check the Support Portal for firmware updates related to your drive.
  3. Replace the drive.
  4. Check for any other RAID-related errors.
- **806f010f-220100ff : The System [ComputerSystemElementName] encountered a firmware hang.**

A system firmware hang has been detected.

**Severity**

Error

**Serviceable**

Yes

**Automatically notify support**

No

**Alert Category**

System - Boot failure

**SNMP Trap ID**

25

**CIM Information**

**Prefix: PLAT ID:** 0186

**User Response**

This is a UEFI detected event. The UEFI diagnostic code for this event can be found in the logged IMM message text. Please refer to the UEFI diagnostic code in the "UEFI diagnostic code" section of the Info Center for the appropriate user response.

**Related links**

– “Finding the UEFI diagnostic code” on page 776

- **806f010f-2201ffff : The System [ComputerSystemElementName] encountered a firmware hang.**

A system firmware hang has been detected.

**Severity**

Error

**Serviceable**

Yes

**Automatically notify support**

No

**Alert Category**

System - Boot failure

**SNMP Trap ID**

25

**CIM Information**

**Prefix: PLAT ID:** 0186

**User Response**

This is a UEFI detected event. The UEFI diagnostic code for this event can be found in the logged IMM message text. Please refer to the UEFI diagnostic code in the "UEFI diagnostic code" section of the Info Center for the appropriate user response.

**Related links**

– “Finding the UEFI diagnostic code” on page 776

- **806f011b-0c01ffff : The connector LightPath has encountered a configuration error.**

The light path LED card is not detected.

**Severity**

Error

**Serviceable**

Yes

**Automatically notify support**

Yes

**Alert Category**

Critical - Other

**SNMP Trap ID**

50

**CIM Information**

Prefix: PLAT ID: 0266

**User Response**

Complete the following steps until the problem is solved:

1. Make sure that the cable from the light path LED card to the system board is securely connected.
2. Replace the light path diagnostics panel.

- **806f011b-1f03ffff : The connector [PhysicalConnectorElementName] has encountered a configuration error.**

The SAS cable connections between the SAS backplane 1 and the system board are not complete.

**Severity**

Error

**Serviceable**

Yes

**Automatically notify support**

Yes

**Alert Category**

Critical - Other

**SNMP Trap ID**

50

**CIM Information**

Prefix: PLAT ID: 0266

**User Response**

1. Check the connections of the SAS cable between the disk and the backplane
2. (Trained service personnel only).

- **806f011b-1f04ffff : The connector [PhysicalConnectorElementName] has encountered a configuration error.**

The SAS cable connections between the SAS backplane 2 and the system board are not complete.

**Severity**

Error

**Serviceable**

Yes

**Automatically notify support**

Yes

**Alert Category**

Critical - Other

**SNMP Trap ID**

50

**CIM Information**

Prefix: PLAT ID: 0266

**User Response**

1. Check the connections of the SAS cable between the disk and the backplane
  2. (Trained service personnel only).
- **806f0123-2101ffff : Reboot of system [ComputerSystemElementName] initiated by IPMI Watchdog.**  
The IPMI watchdog timer has expired. The compute node has restarted.

**Severity**

Info

**Serviceable**

No

**Automatically notify support**

No

**Alert Category**

System - Other

**SNMP Trap ID**

**CIM Information**

Prefix: PLAT ID: 0370

**User Response**

- Information only; no action is required.
- **806f0207-0301ffff : CPU 1 has Failed with FRB1/BIST condition.**  
A Processor has Failed - FRB1/BIST condition.

**Severity**

Error

**Serviceable**

Yes

**Automatically notify support**

No

**Alert Category**

Critical - CPU

**SNMP Trap ID**

40

**CIM Information**

Prefix: PLAT ID: 0044

**User Response**

This is a UEFI detected event. The UEFI diagnostic code for this event can be found in the logged IMM message text. Please refer to the UEFI diagnostic code in the "UEFI diagnostic code" section of the Information Center for the appropriate user response.

**Related links**

- "Finding the UEFI diagnostic code" on page 776
- **806f0207-0302ffff : CPU 2 has Failed with FRB1/BIST condition.**

A Processor has Failed - FRB1/BIST condition.

**Severity**

Error

**Serviceable**

Yes

**Automatically notify support**

Yes

**Alert Category**

Critical - CPU

**SNMP Trap ID**

40

**CIM Information**

**Prefix:** PLAT ID: 0044

**User Response**

This is a UEFI detected event. The UEFI diagnostic code for this event can be found in the logged IMM message text. Please refer to the UEFI diagnostic code in the "UEFI diagnostic code" section of the Information Center for the appropriate user response.

**Related links**

- "Finding the UEFI diagnostic code" on page 776
- **806f0207-0303ffff : CPU 3 has Failed with FRB1/BIST condition.**

A Processor Failed - FRB1/BIST condition.

**Severity**

Error

**Serviceable**

Yes

**Automatically notify support**

No

**Alert Category**

Critical - CPU

**SNMP Trap ID**

40

**CIM Information**

**Prefix:** PLAT ID: 0044

**User Response**

This is a UEFI detected event. The UEFI diagnostic code for this event can be found in the logged IMM message text. Please refer to the UEFI diagnostic code in the "UEFI diagnostic code" section of the Information Center for the appropriate user response.

**Related links**

- "Finding the UEFI diagnostic code" on page 776

- **806f0207-0304ffff : CPU 4 has Failed with FRB1/BIST condition.**

A Processor has Failed - FRB1/BIST condition.

**Severity**

Error

**Serviceable**

Yes

**Automatically notify support**

No

**Alert Category**

Critical - CPU

**SNMP Trap ID**

40

**CIM Information**

Prefix: PLAT ID: 0044

**User Response**

This is a UEFI detected event. The UEFI diagnostic code for this event can be found in the logged IMM message text. Please refer to the UEFI diagnostic code in the "UEFI diagnostic code" section of the Information Center for the appropriate user response.

**Related links**

- "Finding the UEFI diagnostic code" on page 776

- **806f0207-2584ffff : [ProcessorElementName] has Failed with FRB1/BIST condition.**

A processor failed - FRB1/BIST condition. All CPUs. One of CPUs.

**Severity**

Error

**Serviceable**

Yes

**Automatically notify support**

No

**Alert Category**

Critical - CPU

**SNMP Trap ID**

40

**CIM Information**

Prefix: PLAT ID: 0044

**User Response**

This is a UEFI detected event. The UEFI diagnostic code for this event can be found in the logged IMM message text. Please refer to the UEFI diagnostic code in the "UEFI diagnostic code" section of the Information Center for the appropriate user response.

**Related links**

- "Finding the UEFI diagnostic code" on page 776

- **806f020d-0400ffff : Failure Predicted on drive [StorageVolumeElementName] for array [ComputerSystemElementName].**

Failure predicted (PFA) on the hard drive.

**Severity**



Warning

**Serviceable**

Yes

**Automatically notify support**

Yes

**Alert Category**

System - Predicted Failure

**SNMP Trap ID**

27

**CIM Information**

**Prefix: PLAT ID:** 0168

**User Response**

Replace the hard disk drive at the next maintenance period.

- **806f020d-0401ffff : Failure Predicted on drive [StorageVolumeElementName] for array [ComputerSystemElementName].**

Failure predicted (PFA) on the hard drive.

**Severity**

Warning

**Serviceable**

Yes

**Automatically notify support**

Yes

**Alert Category**

System - Predicted Failure

**SNMP Trap ID**

27

**CIM Information**

**Prefix: PLAT ID:** 0168

**User Response**

Replace the hard disk drive at the next maintenance period.

- **806f020d-0402ffff : Failure Predicted on drive [StorageVolumeElementName] for array [ComputerSystemElementName].**

Failure predicted (PFA) on the hard drive.

**Severity**

Warning

**Serviceable**

Yes

**Automatically notify support**

Yes

**Alert Category**

System - Predicted Failure

**SNMP Trap ID**

27

**CIM Information**

**Prefix:** PLAT ID: 0168

**User Response**

Replace the hard disk drive at the next maintenance period.

- **806f020d-0403ffff : Failure Predicted on drive [StorageVolumeElementName] for array [ComputerSystemElementName].**

Failure predicted (PFA) on the hard drive.

**Severity**

Warning

**Serviceable**

Yes

**Automatically notify support**

Yes

**Alert Category**

System - Predicted Failure

**SNMP Trap ID**

27

**CIM Information**

**Prefix:** PLAT ID: 0168

**User Response**

Replace the hard disk drive at the next maintenance period.

- **806f020d-0404ffff : Failure Predicted on drive [StorageVolumeElementName] for array [ComputerSystemElementName].**

Failure predicted (PFA) on the hard drive.

**Severity**

Warning

**Serviceable**

Yes

**Automatically notify support**

Yes

**Alert Category**

System - Predicted Failure

**SNMP Trap ID**

27

**CIM Information**

**Prefix:** PLAT ID: 0168

**User Response**

Replace the hard disk drive at the next maintenance period.

- **806f020d-0405ffff : Failure Predicted on drive [StorageVolumeElementName] for array [ComputerSystemElementName].**

Failure predicted (PFA) on the hard drive.

**Severity**

Warning

**Serviceable**

Yes

**Automatically notify support**

Yes

**Alert Category**

System - Predicted Failure

**SNMP Trap ID**

27

**CIM Information**

**Prefix:** PLAT ID: 0168

**User Response**

Replace the hard disk drive at the next maintenance period.

- **806f020d-0406ffff : Failure Predicted on drive [StorageVolumeElementName] for array [ComputerSystemElementName].**

Failure predicted (PFA) on the hard drive.

**Severity**

Warning

**Serviceable**

Yes

**Automatically notify support**

Yes

**Alert Category**

System - Predicted Failure

**SNMP Trap ID**

27

**CIM Information**

**Prefix:** PLAT ID: 0168

**User Response**

Replace the hard disk drive at the next maintenance period.

- **806f020d-0407ffff : Failure Predicted on drive [StorageVolumeElementName] for array [ComputerSystemElementName].**

Failure predicted (PFA) on the hard drive.

**Severity**

Warning

**Serviceable**

Yes

**Automatically notify support**

Yes

**Alert Category**

System - Predicted Failure

**SNMP Trap ID**

27

**CIM Information**

**Prefix:** PLAT ID: 0168

**User Response**

Replace the hard disk drive at the next maintenance period.

- **806f0223-2101ffff : Powering off system [ComputerSystemElementName] initiated by IPMI Watchdog.**

The IPMI watchdog timer has expired. The compute node has been powered off.

**Severity**

Info

**Serviceable**

No

**Automatically notify support**

No

**Alert Category**

System - Other

**SNMP Trap ID**

**CIM Information**

Prefix: PLAT ID: 0372

**User Response**

Information only; no action is required.

- **806f0225-1f05ffff : LOM1 has been disabled.**

The LAN On Motherboard (LOM) 1 is disabled.

**Severity**

Info

**Serviceable**

No

**Automatically notify support**

No

**Alert Category**

System - Other

**SNMP Trap ID**

**CIM Information**

Prefix: PLAT ID: 0394

**User Response**

Information only; no action is required.

- **806f0225-1f06ffff : LOM2 has been disabled.**

The LAN On Motherboard (LOM) 2 is disabled.

**Severity**

Info

**Serviceable**

No

**Automatically notify support**

No

**Alert Category**

System - Other

## SNMP Trap ID

### CIM Information

Prefix: PLAT ID: 0394

### User Response

Information only; no action is required.

- **806f030c-2001ffff : Scrub Failure for [PhysicalMemoryElementName] on Subsystem [MemoryElementName].**

Memory error discovered during boot..(not a runtime error).

### Severity

Error

### Serviceable

Yes

### Automatically notify support

Yes

### Alert Category

Critical - Memory

## SNMP Trap ID

41

### CIM Information

Prefix: PLAT ID: 0136

### User Response

This is a UEFI detected event. The UEFI diagnostic code for this event can be found in the logged IMM message text. Please refer to the UEFI diagnostic code in the "UEFI diagnostic code" section of the Information Center for the appropriate user response.

### Related links

– "Finding the UEFI diagnostic code" on page 776

- **806f030c-2002ffff : Scrub Failure for [PhysicalMemoryElementName] on Subsystem [MemoryElementName].**

Memory error discovered during boot..(not a runtime error).

### Severity

Error

### Serviceable

Yes

### Automatically notify support

Yes

### Alert Category

Critical - Memory

## SNMP Trap ID

41

### CIM Information

Prefix: PLAT ID: 0136

### User Response

This is a UEFI detected event. The UEFI diagnostic code for this event can be found in the logged IMM message text. Please refer to the UEFI diagnostic code in the "UEFI diagnostic code" section of the Information Center for the appropriate user response.

**Related links**

- "Finding the UEFI diagnostic code" on page 776
- **806f030c-2003ffff : Scrub Failure for [PhysicalMemoryElementName] on Subsystem [MemoryElementName].**

Memory error discovered during boot..(not a runtime error).

**Severity**

Error

**Serviceable**

Yes

**Automatically notify support**

Yes

**Alert Category**

Critical - Memory

**SNMP Trap ID**

41

**CIM Information**

**Prefix:** PLAT ID: 0136

**User Response**

This is a UEFI detected event. The UEFI diagnostic code for this event can be found in the logged IMM message text. Please refer to the UEFI diagnostic code in the "UEFI diagnostic code" section of the Information Center for the appropriate user response.

**Related links**

- "Finding the UEFI diagnostic code" on page 776
- **806f030c-200401ff : Scrub Failure for [PhysicalMemoryElementName] on Subsystem [MemoryElementName].**

Memory error discovered during boot..(not a runtime error).

**Severity**

Error

**Serviceable**

Yes

**Automatically notify support**

Yes

**Alert Category**

Critical - Memory

**SNMP Trap ID**

41

**CIM Information**

**Prefix:** PLAT ID: 0136

**User Response**

This is a UEFI detected event. The UEFI diagnostic code for this event can be found in the logged IMM message text. Please refer to the UEFI diagnostic code in the "UEFI diagnostic code" section of the Information Center for the appropriate user response.

**Related links**

– “Finding the UEFI diagnostic code” on page 776

- **806f030c-2004ffff : Scrub Failure for [PhysicalMemoryElementName] on Subsystem [MemoryElementName].**

Memory error discovered during boot..(not a runtime error).

**Severity**

Error

**Serviceable**

Yes

**Automatically notify support**

Yes

**Alert Category**

Critical - Memory

**SNMP Trap ID**

41

**CIM Information**

**Prefix:** PLAT ID: 0136

**User Response**

This is a UEFI detected event. The UEFI diagnostic code for this event can be found in the logged IMM message text. Please refer to the UEFI diagnostic code in the "UEFI diagnostic code" section of the Information Center for the appropriate user response.

**Related links**

– “Finding the UEFI diagnostic code” on page 776

- **806f030c-2005ffff : Scrub Failure for [PhysicalMemoryElementName] on Subsystem [MemoryElementName].**

Memory error discovered during boot..(not a runtime error).

**Severity**

Error

**Serviceable**

Yes

**Automatically notify support**

Yes

**Alert Category**

Critical - Memory

**SNMP Trap ID**

41

**CIM Information**

**Prefix:** PLAT ID: 0136

**User Response**

This is a UEFI detected event. The UEFI diagnostic code for this event can be found in the logged IMM message text. Please refer to the UEFI diagnostic code in the "UEFI diagnostic code" section of the Information Center for the appropriate user response.

**Related links**

– “Finding the UEFI diagnostic code” on page 776

- **806f030c-2006ffff : Scrub Failure for [PhysicalMemoryElementName] on Subsystem [MemoryElementName].**

Memory error discovered during boot..(not a runtime error).

**Severity**

Error

**Serviceable**

Yes

**Automatically notify support**

Yes

**Alert Category**

Critical - Memory

**SNMP Trap ID**

41

**CIM Information**

Prefix: PLAT ID: 0136

**User Response**

This is a UEFI detected event. The UEFI diagnostic code for this event can be found in the logged IMM message text. Please refer to the UEFI diagnostic code in the "UEFI diagnostic code" section of the Information Center for the appropriate user response.

**Related links**

– “Finding the UEFI diagnostic code” on page 776

- **806f030c-2007ffff : Scrub Failure for [PhysicalMemoryElementName] on Subsystem [MemoryElementName].**

Memory error discovered during boot..(not a runtime error).

**Severity**

Error

**Serviceable**

Yes

**Automatically notify support**

Yes

**Alert Category**

Critical - Memory

**SNMP Trap ID**

41

**CIM Information**

Prefix: PLAT ID: 0136

**User Response**

This is a UEFI detected event. The UEFI diagnostic code for this event can be found in the logged IMM message text. Please refer to the UEFI diagnostic code in the "UEFI diagnostic code" section of the Information Center for the appropriate user response.

**Related links**

– “Finding the UEFI diagnostic code” on page 776

- **806f030c-2008ffff : Scrub Failure for [PhysicalMemoryElementName] on Subsystem [MemoryElementName].**

Memory error discovered during boot..(not a runtime error).



**Severity**

Error

**Serviceable**

Yes

**Automatically notify support**

Yes

**Alert Category**

Critical - Memory

**SNMP Trap ID**

41

**CIM Information**

**Prefix:** PLAT ID: 0136

**User Response**

This is a UEFI detected event. The UEFI diagnostic code for this event can be found in the logged IMM message text. Please refer to the UEFI diagnostic code in the "UEFI diagnostic code" section of the Information Center for the appropriate user response.

**Related links**

- "Finding the UEFI diagnostic code" on page 776
- **806f030c-2009ffff : Scrub Failure for [PhysicalMemoryElementName] on Subsystem [MemoryElementName].**

Memory error discovered during boot..(not a runtime error).

**Severity**

Error

**Serviceable**

Yes

**Automatically notify support**

Yes

**Alert Category**

Critical - Memory

**SNMP Trap ID**

41

**CIM Information**

**Prefix:** PLAT ID: 0136

**User Response**

This is a UEFI detected event. The UEFI diagnostic code for this event can be found in the logged IMM message text. Please refer to the UEFI diagnostic code in the "UEFI diagnostic code" section of the Information Center for the appropriate user response.

**Related links**

- "Finding the UEFI diagnostic code" on page 776
- **806f030c-200affff : Scrub Failure for [PhysicalMemoryElementName] on Subsystem [MemoryElementName].**

Memory error discovered during boot..(not a runtime error).

**Severity**

Error

**Serviceable**

Yes

**Automatically notify support**

Yes

**Alert Category**

Critical - Memory

**SNMP Trap ID**

41

**CIM Information**

**Prefix:** PLAT ID: 0136

**User Response**

This is a UEFI detected event. The UEFI diagnostic code for this event can be found in the logged IMM message text. Please refer to the UEFI diagnostic code in the "UEFI diagnostic code" section of the Information Center for the appropriate user response.

**Related links**

– "Finding the UEFI diagnostic code" on page 776

- **806f030c-200bffff : Scrub Failure for [PhysicalMemoryElementName] on Subsystem [MemoryElementName].**

Memory error discovered during boot..(not a runtime error).

**Severity**

Error

**Serviceable**

Yes

**Automatically notify support**

Yes

**Alert Category**

Critical - Memory

**SNMP Trap ID**

41

**CIM Information**

**Prefix:** PLAT ID: 0136

**User Response**

This is a UEFI detected event. The UEFI diagnostic code for this event can be found in the logged IMM message text. Please refer to the UEFI diagnostic code in the "UEFI diagnostic code" section of the Information Center for the appropriate user response.

**Related links**

– "Finding the UEFI diagnostic code" on page 776

- **806f030c-200cffff : Scrub Failure for [PhysicalMemoryElementName] on Subsystem [MemoryElementName].**

Memory error discovered during boot..(not a runtime error).

**Severity**

Error

**Serviceable**

Yes

**Automatically notify support**

Yes

**Alert Category**

Critical - Memory

**SNMP Trap ID**

41

**CIM Information**

**Prefix:** PLAT ID: 0136

**User Response**

This is a UEFI detected event. The UEFI diagnostic code for this event can be found in the logged IMM message text. Please refer to the UEFI diagnostic code in the "UEFI diagnostic code" section of the Information Center for the appropriate user response.

**Related links**

- "Finding the UEFI diagnostic code" on page 776
- **806f030c-200dffff : Scrub Failure for [PhysicalMemoryElementName] on Subsystem [MemoryElementName].**

Memory error discovered during boot..(not a runtime error).

**Severity**

Error

**Serviceable**

Yes

**Automatically notify support**

Yes

**Alert Category**

Critical - Memory

**SNMP Trap ID**

41

**CIM Information**

**Prefix:** PLAT ID: 0136

**User Response**

This is a UEFI detected event. The UEFI diagnostic code for this event can be found in the logged IMM message text. Please refer to the UEFI diagnostic code in the "UEFI diagnostic code" section of the Information Center for the appropriate user response.

**Related links**

- "Finding the UEFI diagnostic code" on page 776
- **806f030c-200effff : Scrub Failure for [PhysicalMemoryElementName] on Subsystem [MemoryElementName].**

Memory error discovered during boot..(not a runtime error).

**Severity**

Error

**Serviceable**

Yes

**Automatically notify support**

Yes

**Alert Category**

Critical - Memory

**SNMP Trap ID**

**CIM Information****Prefix:** PLAT ID: 0136**User Response**

This is a UEFI detected event. The UEFI diagnostic code for this event can be found in the logged IMM message text. Please refer to the UEFI diagnostic code in the "UEFI diagnostic code" section of the Information Center for the appropriate user response.

**Related links**

- "Finding the UEFI diagnostic code" on page 776
- **806f030c-200ffff : Scrub Failure for [PhysicalMemoryElementName] on Subsystem [MemoryElementName].**

Memory error discovered during boot..(not a runtime error).

**Severity**

Error

**Serviceable**

Yes

**Automatically notify support**

Yes

**Alert Category**

Critical - Memory

**SNMP Trap ID**

41

**CIM Information****Prefix:** PLAT ID: 0136**User Response**

This is a UEFI detected event. The UEFI diagnostic code for this event can be found in the logged IMM message text. Please refer to the UEFI diagnostic code in the "UEFI diagnostic code" section of the Information Center for the appropriate user response.

**Related links**

- "Finding the UEFI diagnostic code" on page 776
- **806f030c-2010ffff : Scrub Failure for [PhysicalMemoryElementName] on Subsystem [MemoryElementName].**

Memory error discovered during boot..(not a runtime error).

**Severity**

Error

**Serviceable**

Yes

**Automatically notify support**

Yes

**Alert Category**

Critical - Memory

**SNMP Trap ID**

41

**CIM Information****Prefix:** PLAT ID: 0136

**User Response**

This is a UEFI detected event. The UEFI diagnostic code for this event can be found in the logged IMM message text. Please refer to the UEFI diagnostic code in the "UEFI diagnostic code" section of the Information Center for the appropriate user response.

**Related links**

- "Finding the UEFI diagnostic code" on page 776
- **806f030c-2011ffff : Scrub Failure for [PhysicalMemoryElementName] on Subsystem [MemoryElementName].**

Memory error discovered during boot..(not a runtime error).

**Severity**

Error

**Serviceable**

Yes

**Automatically notify support**

Yes

**Alert Category**

Critical - Memory

**SNMP Trap ID**

41

**CIM Information**

**Prefix:** PLAT ID: 0136

**User Response**

This is a UEFI detected event. The UEFI diagnostic code for this event can be found in the logged IMM message text. Please refer to the UEFI diagnostic code in the "UEFI diagnostic code" section of the Information Center for the appropriate user response.

**Related links**

- "Finding the UEFI diagnostic code" on page 776
- **806f030c-2012ffff : Scrub Failure for [PhysicalMemoryElementName] on Subsystem [MemoryElementName].**

Memory error discovered during boot..(not a runtime error).

**Severity**

Error

**Serviceable**

Yes

**Automatically notify support**

Yes

**Alert Category**

Critical - Memory

**SNMP Trap ID**

41

**CIM Information**

**Prefix:** PLAT ID: 0136

**User Response**

This is a UEFI detected event. The UEFI diagnostic code for this event can be found in the logged IMM message text. Please refer to the UEFI diagnostic code in the "UEFI diagnostic code" section of the Information Center for the appropriate user response.

**Related links**

- "Finding the UEFI diagnostic code" on page 776
- **806f030c-2013ffff : Scrub Failure for [PhysicalMemoryElementName] on Subsystem [MemoryElementName].**

Memory error discovered during boot..(not a runtime error).

**Severity**

Error

**Serviceable**

Yes

**Automatically notify support**

Yes

**Alert Category**

Critical - Memory

**SNMP Trap ID**

41

**CIM Information**

Prefix: PLAT ID: 0136

**User Response**

This is a UEFI detected event. The UEFI diagnostic code for this event can be found in the logged IMM message text. Please refer to the UEFI diagnostic code in the "UEFI diagnostic code" section of the Information Center for the appropriate user response.

**Related links**

- "Finding the UEFI diagnostic code" on page 776
- **806f030c-2014ffff : Scrub Failure for [PhysicalMemoryElementName] on Subsystem [MemoryElementName].**

Memory error discovered during boot..(not a runtime error).

**Severity**

Error

**Serviceable**

Yes

**Automatically notify support**

Yes

**Alert Category**

Critical - Memory

**SNMP Trap ID**

41

**CIM Information**

Prefix: PLAT ID: 0136

**User Response**

This is a UEFI detected event. The UEFI diagnostic code for this event can be found in the logged IMM message text. Please refer to the UEFI diagnostic code in the "UEFI diagnostic code" section of the Information Center for the appropriate user response.

**Related links**

– “Finding the UEFI diagnostic code” on page 776

- **806f030c-2015ffff : Scrub Failure for [PhysicalMemoryElementName] on Subsystem [MemoryElementName].**

Memory error discovered during boot..(not a runtime error).

**Severity**

Error

**Serviceable**

Yes

**Automatically notify support**

Yes

**Alert Category**

Critical - Memory

**SNMP Trap ID**

41

**CIM Information**

**Prefix:** PLAT ID: 0136

**User Response**

This is a UEFI detected event. The UEFI diagnostic code for this event can be found in the logged IMM message text. Please refer to the UEFI diagnostic code in the "UEFI diagnostic code" section of the Information Center for the appropriate user response.

**Related links**

– “Finding the UEFI diagnostic code” on page 776

- **806f030c-2016ffff : Scrub Failure for [PhysicalMemoryElementName] on Subsystem [MemoryElementName].**

Memory error discovered during boot..(not a runtime error).

**Severity**

Error

**Serviceable**

Yes

**Automatically notify support**

Yes

**Alert Category**

Critical - Memory

**SNMP Trap ID**

41

**CIM Information**

**Prefix:** PLAT ID: 0136

**User Response**

This is a UEFI detected event. The UEFI diagnostic code for this event can be found in the logged IMM message text. Please refer to the UEFI diagnostic code in the "UEFI diagnostic code" section of the Information Center for the appropriate user response.

**Related links**

– “Finding the UEFI diagnostic code” on page 776

- **806f030c-2017ffff : Scrub Failure for [PhysicalMemoryElementName] on Subsystem [MemoryElementName].**

Memory error discovered during boot..(not a runtime error).

**Severity**

Error

**Serviceable**

Yes

**Automatically notify support**

Yes

**Alert Category**

Critical - Memory

**SNMP Trap ID**

41

**CIM Information**

Prefix: PLAT ID: 0136

**User Response**

This is a UEFI detected event. The UEFI diagnostic code for this event can be found in the logged IMM message text. Please refer to the UEFI diagnostic code in the "UEFI diagnostic code" section of the Information Center for the appropriate user response.

**Related links**

- "Finding the UEFI diagnostic code" on page 776

- **806f030c-2018ffff : Scrub Failure for [PhysicalMemoryElementName] on Subsystem [MemoryElementName].**

Memory error discovered during boot..(not a runtime error).

**Severity**

Error

**Serviceable**

Yes

**Automatically notify support**

Yes

**Alert Category**

Critical - Memory

**SNMP Trap ID**

41

**CIM Information**

Prefix: PLAT ID: 0136

**User Response**

This is a UEFI detected event. The UEFI diagnostic code for this event can be found in the logged IMM message text. Please refer to the UEFI diagnostic code in the "UEFI diagnostic code" section of the Information Center for the appropriate user response.

**Related links**

- "Finding the UEFI diagnostic code" on page 776

- **806f030c-2019ffff : Scrub Failure for [PhysicalMemoryElementName] on Subsystem [MemoryElementName].**

Memory error discovered during boot..(not a runtime error).



**Severity**

Error

**Serviceable**

Yes

**Automatically notify support**

Yes

**Alert Category**

Critical - Memory

**SNMP Trap ID**

41

**CIM Information**

**Prefix:** PLAT ID: 0136

**User Response**

This is a UEFI detected event. The UEFI diagnostic code for this event can be found in the logged IMM message text. Please refer to the UEFI diagnostic code in the "UEFI diagnostic code" section of the Information Center for the appropriate user response.

**Related links**

- "Finding the UEFI diagnostic code" on page 776
- **806f030c-201affff : Scrub Failure for [PhysicalMemoryElementName] on Subsystem [MemoryElementName].**

Memory error discovered during boot..(not a runtime error).

**Severity**

Error

**Serviceable**

Yes

**Automatically notify support**

Yes

**Alert Category**

Critical - Memory

**SNMP Trap ID**

41

**CIM Information**

**Prefix:** PLAT ID: 0136

**User Response**

This is a UEFI detected event. The UEFI diagnostic code for this event can be found in the logged IMM message text. Please refer to the UEFI diagnostic code in the "UEFI diagnostic code" section of the Information Center for the appropriate user response.

**Related links**

- "Finding the UEFI diagnostic code" on page 776
- **806f030c-201bffff : Scrub Failure for [PhysicalMemoryElementName] on Subsystem [MemoryElementName].**

Memory error discovered during boot..(not a runtime error).

**Severity**

Error

**Serviceable**

Yes

**Automatically notify support**

Yes

**Alert Category**

Critical - Memory

**SNMP Trap ID**

41

**CIM Information**

**Prefix: PLAT ID:** 0136

**User Response**

This is a UEFI detected event. The UEFI diagnostic code for this event can be found in the logged IMM message text. Please refer to the UEFI diagnostic code in the "UEFI diagnostic code" section of the Information Center for the appropriate user response.

**Related links**

– "Finding the UEFI diagnostic code" on page 776

- **806f030c-201cffff : Scrub Failure for [PhysicalMemoryElementName] on Subsystem [MemoryElementName].**

Memory error discovered during boot..(not a runtime error).

**Severity**

Error

**Serviceable**

Yes

**Automatically notify support**

Yes

**Alert Category**

Critical - Memory

**SNMP Trap ID**

41

**CIM Information**

**Prefix: PLAT ID:** 0136

**User Response**

This is a UEFI detected event. The UEFI diagnostic code for this event can be found in the logged IMM message text. Please refer to the UEFI diagnostic code in the "UEFI diagnostic code" section of the Information Center for the appropriate user response.

**Related links**

– "Finding the UEFI diagnostic code" on page 776

- **806f030c-201dffff : Scrub Failure for [PhysicalMemoryElementName] on Subsystem [MemoryElementName].**

Memory error discovered during boot..(not a runtime error).

**Severity**

Error

**Serviceable**

Yes

**Automatically notify support**

Yes

**Alert Category**

Critical - Memory

**SNMP Trap ID**

41

**CIM Information**

**Prefix:** PLAT ID: 0136

**User Response**

This is a UEFI detected event. The UEFI diagnostic code for this event can be found in the logged IMM message text. Please refer to the UEFI diagnostic code in the "UEFI diagnostic code" section of the Information Center for the appropriate user response.

**Related links**

- "Finding the UEFI diagnostic code" on page 776
- **806f030c-201efff : Scrub Failure for [PhysicalMemoryElementName] on Subsystem [MemoryElementName].**

Memory error discovered during boot..(not a runtime error).

**Severity**

Error

**Serviceable**

Yes

**Automatically notify support**

Yes

**Alert Category**

Critical - Memory

**SNMP Trap ID**

41

**CIM Information**

**Prefix:** PLAT ID: 0136

**User Response**

This is a UEFI detected event. The UEFI diagnostic code for this event can be found in the logged IMM message text. Please refer to the UEFI diagnostic code in the "UEFI diagnostic code" section of the Information Center for the appropriate user response.

**Related links**

- "Finding the UEFI diagnostic code" on page 776
- **806f030c-201ffff : Scrub Failure for [PhysicalMemoryElementName] on Subsystem [MemoryElementName].**

Memory error discovered during boot..(not a runtime error).

**Severity**

Error

**Serviceable**

Yes

**Automatically notify support**

Yes

**Alert Category**

Critical - Memory

**SNMP Trap ID**

**CIM Information****Prefix:** PLAT ID: 0136**User Response**

This is a UEFI detected event. The UEFI diagnostic code for this event can be found in the logged IMM message text. Please refer to the UEFI diagnostic code in the "UEFI diagnostic code" section of the Information Center for the appropriate user response.

**Related links**

- "Finding the UEFI diagnostic code" on page 776
- **806f030c-2020ffff : Scrub Failure for [PhysicalMemoryElementName] on Subsystem [MemoryElementName].**

Memory error discovered during boot..(not a runtime error).

**Severity**

Error

**Serviceable**

Yes

**Automatically notify support**

Yes

**Alert Category**

Critical - Memory

**SNMP Trap ID**

41

**CIM Information****Prefix:** PLAT ID: 0136**User Response**

This is a UEFI detected event. The UEFI diagnostic code for this event can be found in the logged IMM message text. Please refer to the UEFI diagnostic code in the "UEFI diagnostic code" section of the Information Center for the appropriate user response.

**Related links**

- "Finding the UEFI diagnostic code" on page 776
- **806f030c-2021ffff : Scrub Failure for [PhysicalMemoryElementName] on Subsystem [MemoryElementName].**

Memory error discovered during boot..(not a runtime error).

**Severity**

Error

**Serviceable**

Yes

**Automatically notify support**

Yes

**Alert Category**

Critical - Memory

**SNMP Trap ID**

41

**CIM Information****Prefix:** PLAT ID: 0136

**User Response**

This is a UEFI detected event. The UEFI diagnostic code for this event can be found in the logged IMM message text. Please refer to the UEFI diagnostic code in the "UEFI diagnostic code" section of the Information Center for the appropriate user response.

**Related links**

- "Finding the UEFI diagnostic code" on page 776
- **806f030c-2022ffff : Scrub Failure for [PhysicalMemoryElementName] on Subsystem [MemoryElementName].**

Memory error discovered during boot..(not a runtime error).

**Severity**

Error

**Serviceable**

Yes

**Automatically notify support**

Yes

**Alert Category**

Critical - Memory

**SNMP Trap ID**

41

**CIM Information**

**Prefix:** PLAT ID: 0136

**User Response**

This is a UEFI detected event. The UEFI diagnostic code for this event can be found in the logged IMM message text. Please refer to the UEFI diagnostic code in the "UEFI diagnostic code" section of the Information Center for the appropriate user response.

**Related links**

- "Finding the UEFI diagnostic code" on page 776
- **806f030c-2023ffff : Scrub Failure for [PhysicalMemoryElementName] on Subsystem [MemoryElementName].**

Memory error discovered during boot..(not a runtime error).

**Severity**

Error

**Serviceable**

Yes

**Automatically notify support**

Yes

**Alert Category**

Critical - Memory

**SNMP Trap ID**

41

**CIM Information**

**Prefix:** PLAT ID: 0136

**User Response**

This is a UEFI detected event. The UEFI diagnostic code for this event can be found in the logged IMM message text. Please refer to the UEFI diagnostic code in the "UEFI diagnostic code" section of the Information Center for the appropriate user response.

**Related links**

- "Finding the UEFI diagnostic code" on page 776
- **806f030c-2024ffff : Scrub Failure for [PhysicalMemoryElementName] on Subsystem [MemoryElementName].**

Memory error discovered during boot..(not a runtime error).

**Severity**

Error

**Serviceable**

Yes

**Automatically notify support**

Yes

**Alert Category**

Critical - Memory

**SNMP Trap ID**

41

**CIM Information**

Prefix: PLAT ID: 0136

**User Response**

This is a UEFI detected event. The UEFI diagnostic code for this event can be found in the logged IMM message text. Please refer to the UEFI diagnostic code in the "UEFI diagnostic code" section of the Information Center for the appropriate user response.

**Related links**

- "Finding the UEFI diagnostic code" on page 776
- **806f030c-2025ffff : Scrub Failure for [PhysicalMemoryElementName] on Subsystem [MemoryElementName].**

Memory error discovered during boot..(not a runtime error).

**Severity**

Error

**Serviceable**

Yes

**Automatically notify support**

Yes

**Alert Category**

Critical - Memory

**SNMP Trap ID**

41

**CIM Information**

Prefix: PLAT ID: 0136

**User Response**

This is a UEFI detected event. The UEFI diagnostic code for this event can be found in the logged IMM message text. Please refer to the UEFI diagnostic code in the "UEFI diagnostic code" section of the Information Center for the appropriate user response.

**Related links**

– “Finding the UEFI diagnostic code” on page 776

- **806f030c-2026ffff : Scrub Failure for [PhysicalMemoryElementName] on Subsystem [MemoryElementName].**

Memory error discovered during boot..(not a runtime error).

**Severity**

Error

**Serviceable**

Yes

**Automatically notify support**

Yes

**Alert Category**

Critical - Memory

**SNMP Trap ID**

41

**CIM Information**

**Prefix:** PLAT ID: 0136

**User Response**

This is a UEFI detected event. The UEFI diagnostic code for this event can be found in the logged IMM message text. Please refer to the UEFI diagnostic code in the "UEFI diagnostic code" section of the Information Center for the appropriate user response.

**Related links**

– “Finding the UEFI diagnostic code” on page 776

- **806f030c-2027ffff : Scrub Failure for [PhysicalMemoryElementName] on Subsystem [MemoryElementName].**

Memory error discovered during boot..(not a runtime error).

**Severity**

Error

**Serviceable**

Yes

**Automatically notify support**

Yes

**Alert Category**

Critical - Memory

**SNMP Trap ID**

41

**CIM Information**

**Prefix:** PLAT ID: 0136

**User Response**

This is a UEFI detected event. The UEFI diagnostic code for this event can be found in the logged IMM message text. Please refer to the UEFI diagnostic code in the "UEFI diagnostic code" section of the Information Center for the appropriate user response.

**Related links**

– “Finding the UEFI diagnostic code” on page 776

- **806f030c-202802ff : Scrub Failure for [PhysicalMemoryElementName] on Subsystem [MemoryElementName].**

Memory error discovered during boot..(not a runtime error).

**Severity**

Error

**Serviceable**

Yes

**Automatically notify support**

Yes

**Alert Category**

Critical - Memory

**SNMP Trap ID**

41

**CIM Information**

Prefix: PLAT ID: 0136

**User Response**

This is a UEFI detected event. The UEFI diagnostic code for this event can be found in the logged IMM message text. Please refer to the UEFI diagnostic code in the "UEFI diagnostic code" section of the Information Center for the appropriate user response.

**Related links**

- "Finding the UEFI diagnostic code" on page 776

- **806f030c-2028ffff : Scrub Failure for [PhysicalMemoryElementName] on Subsystem [MemoryElementName].**

Memory error discovered during boot..(not a runtime error).

**Severity**

Error

**Serviceable**

Yes

**Automatically notify support**

Yes

**Alert Category**

Critical - Memory

**SNMP Trap ID**

41

**CIM Information**

Prefix: PLAT ID: 0136

**User Response**

This is a UEFI detected event. The UEFI diagnostic code for this event can be found in the logged IMM message text. Please refer to the UEFI diagnostic code in the "UEFI diagnostic code" section of the Information Center for the appropriate user response.

**Related links**

- "Finding the UEFI diagnostic code" on page 776

- **806f030c-2029ffff : Scrub Failure for [PhysicalMemoryElementName] on Subsystem [MemoryElementName].**

Memory error discovered during boot..(not a runtime error).



**Severity**

Error

**Serviceable**

Yes

**Automatically notify support**

Yes

**Alert Category**

Critical - Memory

**SNMP Trap ID**

41

**CIM Information**

**Prefix:** PLAT ID: 0136

**User Response**

This is a UEFI detected event. The UEFI diagnostic code for this event can be found in the logged IMM message text. Please refer to the UEFI diagnostic code in the "UEFI diagnostic code" section of the Information Center for the appropriate user response.

**Related links**

- "Finding the UEFI diagnostic code" on page 776
- **806f030c-202affff : Scrub Failure for [PhysicalMemoryElementName] on Subsystem [MemoryElementName].**

Memory error discovered during boot..(not a runtime error).

**Severity**

Error

**Serviceable**

Yes

**Automatically notify support**

Yes

**Alert Category**

Critical - Memory

**SNMP Trap ID**

41

**CIM Information**

**Prefix:** PLAT ID: 0136

**User Response**

This is a UEFI detected event. The UEFI diagnostic code for this event can be found in the logged IMM message text. Please refer to the UEFI diagnostic code in the "UEFI diagnostic code" section of the Information Center for the appropriate user response.

**Related links**

- "Finding the UEFI diagnostic code" on page 776
- **806f030c-202bffff : Scrub Failure for [PhysicalMemoryElementName] on Subsystem [MemoryElementName].**

Memory error discovered during boot..(not a runtime error).

**Severity**

Error

**Serviceable**

Yes

**Automatically notify support**

Yes

**Alert Category**

Critical - Memory

**SNMP Trap ID**

41

**CIM Information**

**Prefix:** PLAT ID: 0136

**User Response**

This is a UEFI detected event. The UEFI diagnostic code for this event can be found in the logged IMM message text. Please refer to the UEFI diagnostic code in the "UEFI diagnostic code" section of the Information Center for the appropriate user response.

**Related links**

– "Finding the UEFI diagnostic code" on page 776

- **806f030c-202cffff : Scrub Failure for [PhysicalMemoryElementName] on Subsystem [MemoryElementName].**

Memory error discovered during boot..(not a runtime error).

**Severity**

Error

**Serviceable**

Yes

**Automatically notify support**

Yes

**Alert Category**

Critical - Memory

**SNMP Trap ID**

41

**CIM Information**

**Prefix:** PLAT ID: 0136

**User Response**

This is a UEFI detected event. The UEFI diagnostic code for this event can be found in the logged IMM message text. Please refer to the UEFI diagnostic code in the "UEFI diagnostic code" section of the Information Center for the appropriate user response.

**Related links**

– "Finding the UEFI diagnostic code" on page 776

- **806f030c-202dffff : Scrub Failure for [PhysicalMemoryElementName] on Subsystem [MemoryElementName].**

Memory error discovered during boot..(not a runtime error).

**Severity**

Error

**Serviceable**

Yes

**Automatically notify support**

Yes

**Alert Category**

Critical - Memory

**SNMP Trap ID**

41

**CIM Information**

**Prefix:** PLAT ID: 0136

**User Response**

This is a UEFI detected event. The UEFI diagnostic code for this event can be found in the logged IMM message text. Please refer to the UEFI diagnostic code in the "UEFI diagnostic code" section of the Information Center for the appropriate user response.

**Related links**

- "Finding the UEFI diagnostic code" on page 776
- **806f030c-202effff : Scrub Failure for [PhysicalMemoryElementName] on Subsystem [MemoryElementName].**

Memory error discovered during boot..(not a runtime error).

**Severity**

Error

**Serviceable**

Yes

**Automatically notify support**

Yes

**Alert Category**

Critical - Memory

**SNMP Trap ID**

41

**CIM Information**

**Prefix:** PLAT ID: 0136

**User Response**

This is a UEFI detected event. The UEFI diagnostic code for this event can be found in the logged IMM message text. Please refer to the UEFI diagnostic code in the "UEFI diagnostic code" section of the Information Center for the appropriate user response.

**Related links**

- "Finding the UEFI diagnostic code" on page 776
- **806f030c-202fffff : Scrub Failure for [PhysicalMemoryElementName] on Subsystem [MemoryElementName].**

Memory error discovered during boot..(not a runtime error).

**Severity**

Error

**Serviceable**

Yes

**Automatically notify support**

Yes

**Alert Category**

Critical - Memory

**SNMP Trap ID**

**CIM Information****Prefix:** PLAT ID: 0136**User Response**

This is a UEFI detected event. The UEFI diagnostic code for this event can be found in the logged IMM message text. Please refer to the UEFI diagnostic code in the "UEFI diagnostic code" section of the Information Center for the appropriate user response.

**Related links**

- "Finding the UEFI diagnostic code" on page 776
- **806f030c-2030ffff : Scrub Failure for [PhysicalMemoryElementName] on Subsystem [MemoryElementName].**

Memory error discovered during boot..(not a runtime error).

**Severity**

Error

**Serviceable**

Yes

**Automatically notify support**

Yes

**Alert Category**

Critical - Memory

**SNMP Trap ID**

41

**CIM Information****Prefix:** PLAT ID: 0136**User Response**

This is a UEFI detected event. The UEFI diagnostic code for this event can be found in the logged IMM message text. Please refer to the UEFI diagnostic code in the "UEFI diagnostic code" section of the Information Center for the appropriate user response.

**Related links**

- "Finding the UEFI diagnostic code" on page 776
- **806f030c-2581ffff : Scrub Failure for [PhysicalMemoryElementName] on Subsystem [MemoryElementName].**

Memory error discovered during boot..(not a runtime error).

**Severity**

Error

**Serviceable**

Yes

**Automatically notify support**

Yes

**Alert Category**

Critical - Memory

**SNMP Trap ID**

41

**CIM Information****Prefix:** PLAT ID: 0136

**User Response**

This is a UEFI detected event. The UEFI diagnostic code for this event can be found in the logged IMM message text. Please refer to the UEFI diagnostic code in the "UEFI diagnostic code" section of the Information Center for the appropriate user response.

**Related links**

– “Finding the UEFI diagnostic code” on page 776

- **806f030d-0400ffff : Hot Spare enabled for [ComputerSystemElementName].**

A hot spare is available.

**Severity**

Info

**Serviceable**

No

**Automatically notify support**

No

**Alert Category**

System - Other

**SNMP Trap ID****CIM Information**

Prefix: PLAT ID: 0170

**User Response**

Information only; no action required.

- **806f030d-0401ffff : Hot Spare enabled for [ComputerSystemElementName].**

A hot spare is available.

**Severity**

Info

**Serviceable**

No

**Automatically notify support**

No

**Alert Category**

System - Other

**SNMP Trap ID****CIM Information**

Prefix: PLAT ID: 0170

**User Response**

Information only; no action required.

- **806f030d-0402ffff : Hot Spare enabled for [ComputerSystemElementName].**

A hot spare is available.

**Severity**

Info

**Serviceable**

No

**Automatically notify support**

No

**Alert Category**

System - Other

**SNMP Trap ID**

**CIM Information**

Prefix: PLAT ID: 0170

**User Response**

Information only; no action required.

- **806f030d-0403ffff : Hot Spare enabled for [ComputerSystemElementName].**

A hot spare is available.

**Severity**

Info

**Serviceable**

No

**Automatically notify support**

No

**Alert Category**

System - Other

**SNMP Trap ID**

**CIM Information**

Prefix: PLAT ID: 0170

**User Response**

Information only; no action required.

- **806f030d-0404ffff : Hot Spare enabled for [ComputerSystemElementName].**

A hot spare is available.

**Severity**

Info

**Serviceable**

No

**Automatically notify support**

No

**Alert Category**

System - Other

**SNMP Trap ID**

**CIM Information**

Prefix: PLAT ID: 0170

**User Response**

Information only; no action required.

- **806f030d-0405ffff : Hot Spare enabled for [ComputerSystemElementName].**

A hot spare is available.

**Severity**

Info

**Serviceable**

No

**Automatically notify support**

No

**Alert Category**

System - Other

**SNMP Trap ID****CIM Information****Prefix: PLAT ID:** 0170**User Response**

Information only; no action required.

- **806f030d-0406ffff : Hot Spare enabled for [ComputerSystemElementName].**

A hot spare is available.

**Severity**

Info

**Serviceable**

No

**Automatically notify support**

No

**Alert Category**

System - Other

**SNMP Trap ID****CIM Information****Prefix: PLAT ID:** 0170**User Response**

Information only; no action required.

- **806f030d-0407ffff : Hot Spare enabled for [ComputerSystemElementName].**

A hot spare is available.

**Severity**

Info

**Serviceable**

No

**Automatically notify support**

No

**Alert Category**

System - Other

**SNMP Trap ID****CIM Information****Prefix: PLAT ID:** 0170

**User Response**

Information only; no action required.

- **806f0313-1701ffff : A software NMI has occurred on system [ComputerSystemElementName].**

A software NMI has occurred. The compute node might have restarted, depending on the configuration setting.

**Severity**

Error

**Serviceable**

Yes

**Automatically notify support**

No

**Alert Category**

Critical - Other

**SNMP Trap ID**

50

**CIM Information**

Prefix: PLAT ID: 0228

**User Response**

Check the operating-system logs and resolve any issues related the NMI.

- **806f0323-2101ffff : Power cycle of system [ComputerSystemElementName] initiated by watchdog IPMI Watchdog.**

The IPMI watchdog timer has expired. The compute node has been powered off and powered on.

**Severity**

Info

**Serviceable**

No

**Automatically notify support**

No

**Alert Category**

System - Other

**SNMP Trap ID****CIM Information**

Prefix: PLAT ID: 0374

**User Response**

Information only; no action is required.

- **806f040c-2001ffff : [PhysicalMemoryElementName] Disabled on Subsystem [MemoryElementName].**

Memory has been Disabled.

**Severity**

Info

**Serviceable**

No

**Automatically notify support**



No

**Alert Category**

System - Other

**SNMP Trap ID**

**CIM Information**

**Prefix:** PLAT ID: 0131

**User Response**

This is a UEFI detected event. The UEFI diagnostic code for this event can be found in the logged IMM message text. Please refer to the UEFI diagnostic code in the "UEFI diagnostic code" section of the Information Center for the appropriate user response.

**Related links**

- "Finding the UEFI diagnostic code" on page 776
- **806f040c-2002ffff : [PhysicalMemoryElementName] Disabled on Subsystem [MemoryElementName].**

Memory has been Disabled.

**Severity**

Info

**Serviceable**

No

**Automatically notify support**

No

**Alert Category**

System - Other

**SNMP Trap ID**

**CIM Information**

**Prefix:** PLAT ID: 0131

**User Response**

This is a UEFI detected event. The UEFI diagnostic code for this event can be found in the logged IMM message text. Please refer to the UEFI diagnostic code in the "UEFI diagnostic code" section of the Information Center for the appropriate user response.

**Related links**

- "Finding the UEFI diagnostic code" on page 776
- **806f040c-2003ffff : [PhysicalMemoryElementName] Disabled on Subsystem [MemoryElementName].**

Memory has been Disabled.

**Severity**

Info

**Serviceable**

No

**Automatically notify support**

No

**Alert Category**

System - Other

## SNMP Trap ID

### CIM Information

Prefix: PLAT ID: 0131

### User Response

This is a UEFI detected event. The UEFI diagnostic code for this event can be found in the logged IMM message text. Please refer to the UEFI diagnostic code in the "UEFI diagnostic code" section of the Information Center for the appropriate user response.

### Related links

– “Finding the UEFI diagnostic code” on page 776

- **806f040c-2004ffff : [PhysicalMemoryElementName] Disabled on Subsystem [MemoryElementName].**

Memory has been Disabled.

### Severity

Info

### Serviceable

No

### Automatically notify support

No

### Alert Category

System - Other

## SNMP Trap ID

### CIM Information

Prefix: PLAT ID: 0131

### User Response

This is a UEFI detected event. The UEFI diagnostic code for this event can be found in the logged IMM message text. Please refer to the UEFI diagnostic code in the "UEFI diagnostic code" section of the Information Center for the appropriate user response.

### Related links

– “Finding the UEFI diagnostic code” on page 776

- **806f040c-2005ffff : [PhysicalMemoryElementName] Disabled on Subsystem [MemoryElementName].**

Memory has been Disabled.

### Severity

Info

### Serviceable

No

### Automatically notify support

No

### Alert Category

System - Other

## SNMP Trap ID

### CIM Information

**Prefix:** PLAT ID: 0131

**User Response**

This is a UEFI detected event. The UEFI diagnostic code for this event can be found in the logged IMM message text. Please refer to the UEFI diagnostic code in the "UEFI diagnostic code" section of the Information Center for the appropriate user response.

**Related links**

- "Finding the UEFI diagnostic code" on page 776
- **806f040c-2006ffff : [PhysicalMemoryElementName] Disabled on Subsystem [MemoryElementName].**  
Memory has been Disabled.

**Severity**

Info

**Serviceable**

No

**Automatically notify support**

No

**Alert Category**

System - Other

**SNMP Trap ID**

**CIM Information**

**Prefix:** PLAT ID: 0131

**User Response**

This is a UEFI detected event. The UEFI diagnostic code for this event can be found in the logged IMM message text. Please refer to the UEFI diagnostic code in the "UEFI diagnostic code" section of the Information Center for the appropriate user response.

**Related links**

- "Finding the UEFI diagnostic code" on page 776
- **806f040c-2007ffff : [PhysicalMemoryElementName] Disabled on Subsystem [MemoryElementName].**  
Memory has been Disabled.

**Severity**

Info

**Serviceable**

No

**Automatically notify support**

No

**Alert Category**

System - Other

**SNMP Trap ID**

**CIM Information**

**Prefix:** PLAT ID: 0131

**User Response**

This is a UEFI detected event. The UEFI diagnostic code for this event can be found in the logged IMM message text. Please refer to the UEFI diagnostic code in the "UEFI diagnostic code" section of the Information Center for the appropriate user response.

**Related links**

– “Finding the UEFI diagnostic code” on page 776

- **806f040c-2008ffff : [PhysicalMemoryElementName] Disabled on Subsystem [MemoryElementName].**

Memory has been Disabled.

**Severity**

Info

**Serviceable**

No

**Automatically notify support**

No

**Alert Category**

System - Other

**SNMP Trap ID****CIM Information**

Prefix: PLAT ID: 0131

**User Response**

This is a UEFI detected event. The UEFI diagnostic code for this event can be found in the logged IMM message text. Please refer to the UEFI diagnostic code in the "UEFI diagnostic code" section of the Information Center for the appropriate user response.

**Related links**

– “Finding the UEFI diagnostic code” on page 776

- **806f040c-2009ffff : [PhysicalMemoryElementName] Disabled on Subsystem [MemoryElementName].**

Memory has been Disabled.

**Severity**

Info

**Serviceable**

No

**Automatically notify support**

No

**Alert Category**

System - Other

**SNMP Trap ID****CIM Information**

Prefix: PLAT ID: 0131

**User Response**

This is a UEFI detected event. The UEFI diagnostic code for this event can be found in the logged IMM message text. Please refer to the UEFI diagnostic code in the "UEFI diagnostic code" section of the Information Center for the appropriate user response.

**Related links**

– “Finding the UEFI diagnostic code” on page 776

- **806f040c-200affff : [PhysicalMemoryElementName] Disabled on Subsystem [MemoryElementName].**

Memory has been Disabled.

**Severity**

Info

**Serviceable**

No

**Automatically notify support**

No

**Alert Category**

System - Other

**SNMP Trap ID****CIM Information**

Prefix: PLAT ID: 0131

**User Response**

This is a UEFI detected event. The UEFI diagnostic code for this event can be found in the logged IMM message text. Please refer to the UEFI diagnostic code in the "UEFI diagnostic code" section of the Information Center for the appropriate user response.

**Related links**

– “Finding the UEFI diagnostic code” on page 776

- **806f040c-200bffff : [PhysicalMemoryElementName] Disabled on Subsystem [MemoryElementName].**

Memory has been Disabled.

**Severity**

Info

**Serviceable**

No

**Automatically notify support**

No

**Alert Category**

System - Other

**SNMP Trap ID****CIM Information**

Prefix: PLAT ID: 0131

**User Response**

This is a UEFI detected event. The UEFI diagnostic code for this event can be found in the logged IMM message text. Please refer to the UEFI diagnostic code in the "UEFI diagnostic code" section of the Information Center for the appropriate user response.

**Related links**

– “Finding the UEFI diagnostic code” on page 776

- **806f040c-200cffff : [PhysicalMemoryElementName] Disabled on Subsystem [MemoryElementName].**

Memory has been Disabled.

**Severity**

Info

**Serviceable**

No

**Automatically notify support**

No

**Alert Category**

System - Other

**SNMP Trap ID**

**CIM Information**

Prefix: PLAT ID: 0131

**User Response**

This is a UEFI detected event. The UEFI diagnostic code for this event can be found in the logged IMM message text. Please refer to the UEFI diagnostic code in the "UEFI diagnostic code" section of the Information Center for the appropriate user response.

**Related links**

– "Finding the UEFI diagnostic code" on page 776

- **806f040c-200dffff : [PhysicalMemoryElementName] Disabled on Subsystem [MemoryElementName].**

Memory has been Disabled.

**Severity**

Info

**Serviceable**

No

**Automatically notify support**

No

**Alert Category**

System - Other

**SNMP Trap ID**

**CIM Information**

Prefix: PLAT ID: 0131

**User Response**

This is a UEFI detected event. The UEFI diagnostic code for this event can be found in the logged IMM message text. Please refer to the UEFI diagnostic code in the "UEFI diagnostic code" section of the Information Center for the appropriate user response.

**Related links**

– "Finding the UEFI diagnostic code" on page 776

- **806f040c-200effff : [PhysicalMemoryElementName] Disabled on Subsystem [MemoryElementName].**

Memory has been Disabled.

**Severity**

Info

**Serviceable**

No

**Automatically notify support**

No

**Alert Category**

System - Other

**SNMP Trap ID****CIM Information****Prefix:** PLAT ID: 0131**User Response**

This is a UEFI detected event. The UEFI diagnostic code for this event can be found in the logged IMM message text. Please refer to the UEFI diagnostic code in the "UEFI diagnostic code" section of the Information Center for the appropriate user response.

**Related links**

- "Finding the UEFI diagnostic code" on page 776
- **806f040c-200ffff : [PhysicalMemoryElementName] Disabled on Subsystem [MemoryElementName].**

Memory has been Disabled.

**Severity**

Info

**Serviceable**

No

**Automatically notify support**

No

**Alert Category**

System - Other

**SNMP Trap ID****CIM Information****Prefix:** PLAT ID: 0131**User Response**

This is a UEFI detected event. The UEFI diagnostic code for this event can be found in the logged IMM message text. Please refer to the UEFI diagnostic code in the "UEFI diagnostic code" section of the Information Center for the appropriate user response.

**Related links**

- "Finding the UEFI diagnostic code" on page 776
- **806f040c-2010ffff : [PhysicalMemoryElementName] Disabled on Subsystem [MemoryElementName].**

Memory has been Disabled.

**Severity**

Info

**Serviceable**

No

**Automatically notify support**

No

**Alert Category**

System - Other

**SNMP Trap ID**

**CIM Information**

Prefix: PLAT ID: 0131

**User Response**

This is a UEFI detected event. The UEFI diagnostic code for this event can be found in the logged IMM message text. Please refer to the UEFI diagnostic code in the "UEFI diagnostic code" section of the Information Center for the appropriate user response.

**Related links**

– "Finding the UEFI diagnostic code" on page 776

- **806f040c-2011ffff : [PhysicalMemoryElementName] Disabled on Subsystem [MemoryElementName].**

Memory has been Disabled.

**Severity**

Info

**Serviceable**

No

**Automatically notify support**

No

**Alert Category**

System - Other

**SNMP Trap ID**

**CIM Information**

Prefix: PLAT ID: 0131

**User Response**

This is a UEFI detected event. The UEFI diagnostic code for this event can be found in the logged IMM message text. Please refer to the UEFI diagnostic code in the "UEFI diagnostic code" section of the Information Center for the appropriate user response.

**Related links**

– "Finding the UEFI diagnostic code" on page 776

- **806f040c-2012ffff : [PhysicalMemoryElementName] Disabled on Subsystem [MemoryElementName].**

Memory has been Disabled.

**Severity**

Info

**Serviceable**

No

**Automatically notify support**

No



**Alert Category**

System - Other

**SNMP Trap ID****CIM Information**

Prefix: PLAT ID: 0131

**User Response**

This is a UEFI detected event. The UEFI diagnostic code for this event can be found in the logged IMM message text. Please refer to the UEFI diagnostic code in the "UEFI diagnostic code" section of the Information Center for the appropriate user response.

**Related links**

- "Finding the UEFI diagnostic code" on page 776
- **806f040c-2013ffff : [PhysicalMemoryElementName] Disabled on Subsystem [MemoryElementName].**

Memory has been Disabled.

**Severity**

Info

**Serviceable**

No

**Automatically notify support**

No

**Alert Category**

System - Other

**SNMP Trap ID****CIM Information**

Prefix: PLAT ID: 0131

**User Response**

This is a UEFI detected event. The UEFI diagnostic code for this event can be found in the logged IMM message text. Please refer to the UEFI diagnostic code in the "UEFI diagnostic code" section of the Information Center for the appropriate user response.

**Related links**

- "Finding the UEFI diagnostic code" on page 776
- **806f040c-2014ffff : [PhysicalMemoryElementName] Disabled on Subsystem [MemoryElementName].**

Memory has been Disabled.

**Severity**

Info

**Serviceable**

No

**Automatically notify support**

No

**Alert Category**

System - Other

**SNMP Trap ID**

**CIM Information**

Prefix: PLAT ID: 0131

**User Response**

This is a UEFI detected event. The UEFI diagnostic code for this event can be found in the logged IMM message text. Please refer to the UEFI diagnostic code in the "UEFI diagnostic code" section of the Information Center for the appropriate user response.

**Related links**

– "Finding the UEFI diagnostic code" on page 776

- **806f040c-2015ffff : [PhysicalMemoryElementName] Disabled on Subsystem [MemoryElementName].**

Memory has been Disabled.

**Severity**

Info

**Serviceable**

No

**Automatically notify support**

No

**Alert Category**

System - Other

**SNMP Trap ID****CIM Information**

Prefix: PLAT ID: 0131

**User Response**

This is a UEFI detected event. The UEFI diagnostic code for this event can be found in the logged IMM message text. Please refer to the UEFI diagnostic code in the "UEFI diagnostic code" section of the Information Center for the appropriate user response.

**Related links**

– "Finding the UEFI diagnostic code" on page 776

- **806f040c-2016ffff : [PhysicalMemoryElementName] Disabled on Subsystem [MemoryElementName].**

Memory has been Disabled.

**Severity**

Info

**Serviceable**

No

**Automatically notify support**

No

**Alert Category**

System - Other

**SNMP Trap ID****CIM Information**

Prefix: PLAT ID: 0131

**User Response**

This is a UEFI detected event. The UEFI diagnostic code for this event can be found in the logged IMM message text. Please refer to the UEFI diagnostic code in the "UEFI diagnostic code" section of the Information Center for the appropriate user response.

**Related links**

- "Finding the UEFI diagnostic code" on page 776
- **806f040c-2017ffff : [PhysicalMemoryElementName] Disabled on Subsystem [MemoryElementName].**

Memory has been Disabled.

**Severity**

Info

**Serviceable**

No

**Automatically notify support**

No

**Alert Category**

System - Other

**SNMP Trap ID****CIM Information**

Prefix: PLAT ID: 0131

**User Response**

This is a UEFI detected event. The UEFI diagnostic code for this event can be found in the logged IMM message text. Please refer to the UEFI diagnostic code in the "UEFI diagnostic code" section of the Information Center for the appropriate user response.

**Related links**

- "Finding the UEFI diagnostic code" on page 776
- **806f040c-2018ffff : [PhysicalMemoryElementName] Disabled on Subsystem [MemoryElementName].**

Memory has been Disabled.

**Severity**

Info

**Serviceable**

No

**Automatically notify support**

No

**Alert Category**

System - Other

**SNMP Trap ID****CIM Information**

Prefix: PLAT ID: 0131

**User Response**

This is a UEFI detected event. The UEFI diagnostic code for this event can be found in the logged IMM message text. Please refer to the UEFI diagnostic code in the "UEFI diagnostic code" section of the Information Center for the appropriate user response.

**Related links**

– “Finding the UEFI diagnostic code” on page 776

- **806f040c-2019ffff : [PhysicalMemoryElementName] Disabled on Subsystem [MemoryElementName].**

Memory has been Disabled.

**Severity**

Info

**Serviceable**

No

**Automatically notify support**

No

**Alert Category**

System - Other

**SNMP Trap ID**

**CIM Information**

Prefix: PLAT ID: 0131

**User Response**

This is a UEFI detected event. The UEFI diagnostic code for this event can be found in the logged IMM message text. Please refer to the UEFI diagnostic code in the "UEFI diagnostic code" section of the Information Center for the appropriate user response.

**Related links**

– “Finding the UEFI diagnostic code” on page 776

- **806f040c-201affff : [PhysicalMemoryElementName] Disabled on Subsystem [MemoryElementName].**

Memory has been Disabled.

**Severity**

Info

**Serviceable**

No

**Automatically notify support**

No

**Alert Category**

System - Other

**SNMP Trap ID**

**CIM Information**

Prefix: PLAT ID: 0131

**User Response**

This is a UEFI detected event. The UEFI diagnostic code for this event can be found in the logged IMM message text. Please refer to the UEFI diagnostic code in the "UEFI diagnostic code" section of the Information Center for the appropriate user response.

**Related links**

– “Finding the UEFI diagnostic code” on page 776

- **806f040c-201bffff : [PhysicalMemoryElementName] Disabled on Subsystem [MemoryElementName].**

Memory has been Disabled.

**Severity**

Info

**Serviceable**

No

**Automatically notify support**

No

**Alert Category**

System - Other

**SNMP Trap ID****CIM Information**

Prefix: PLAT ID: 0131

**User Response**

This is a UEFI detected event. The UEFI diagnostic code for this event can be found in the logged IMM message text. Please refer to the UEFI diagnostic code in the "UEFI diagnostic code" section of the Information Center for the appropriate user response.

**Related links**

– “Finding the UEFI diagnostic code” on page 776

- **806f040c-201cffff : [PhysicalMemoryElementName] Disabled on Subsystem [MemoryElementName].**

Memory has been Disabled.

**Severity**

Info

**Serviceable**

No

**Automatically notify support**

No

**Alert Category**

System - Other

**SNMP Trap ID****CIM Information**

Prefix: PLAT ID: 0131

**User Response**

This is a UEFI detected event. The UEFI diagnostic code for this event can be found in the logged IMM message text. Please refer to the UEFI diagnostic code in the "UEFI diagnostic code" section of the Information Center for the appropriate user response.

**Related links**

– “Finding the UEFI diagnostic code” on page 776

- **806f040c-201dffff : [PhysicalMemoryElementName] Disabled on Subsystem [MemoryElementName].**

Memory has been Disabled.

**Severity**

Info

**Serviceable**

No

**Automatically notify support**

No

**Alert Category**

System - Other

**SNMP Trap ID**

**CIM Information**

Prefix: PLAT ID: 0131

**User Response**

This is a UEFI detected event. The UEFI diagnostic code for this event can be found in the logged IMM message text. Please refer to the UEFI diagnostic code in the "UEFI diagnostic code" section of the Information Center for the appropriate user response.

**Related links**

– "Finding the UEFI diagnostic code" on page 776

- **806f040c-201effff : [PhysicalMemoryElementName] Disabled on Subsystem [MemoryElementName].**

Memory has been Disabled.

**Severity**

Info

**Serviceable**

No

**Automatically notify support**

No

**Alert Category**

System - Other

**SNMP Trap ID**

**CIM Information**

Prefix: PLAT ID: 0131

**User Response**

This is a UEFI detected event. The UEFI diagnostic code for this event can be found in the logged IMM message text. Please refer to the UEFI diagnostic code in the "UEFI diagnostic code" section of the Information Center for the appropriate user response.

**Related links**

– "Finding the UEFI diagnostic code" on page 776

- **806f040c-201ffff : [PhysicalMemoryElementName] Disabled on Subsystem [MemoryElementName].**

Memory has been Disabled.

**Severity**

Info

**Serviceable**

No

**Automatically notify support**

No

**Alert Category**

System - Other

**SNMP Trap ID****CIM Information****Prefix:** PLAT ID: 0131**User Response**

This is a UEFI detected event. The UEFI diagnostic code for this event can be found in the logged IMM message text. Please refer to the UEFI diagnostic code in the "UEFI diagnostic code" section of the Information Center for the appropriate user response.

**Related links**

- "Finding the UEFI diagnostic code" on page 776
- **806f040c-2020ffff : [PhysicalMemoryElementName] Disabled on Subsystem [MemoryElementName].**

Memory has been Disabled.

**Severity**

Info

**Serviceable**

No

**Automatically notify support**

No

**Alert Category**

System - Other

**SNMP Trap ID****CIM Information****Prefix:** PLAT ID: 0131**User Response**

This is a UEFI detected event. The UEFI diagnostic code for this event can be found in the logged IMM message text. Please refer to the UEFI diagnostic code in the "UEFI diagnostic code" section of the Information Center for the appropriate user response.

**Related links**

- "Finding the UEFI diagnostic code" on page 776
- **806f040c-2021ffff : [PhysicalMemoryElementName] Disabled on Subsystem [MemoryElementName].**

Memory has been Disabled.

**Severity**

Info

**Serviceable**

No

**Automatically notify support**

No

**Alert Category**

System - Other

**SNMP Trap ID**

**CIM Information**

Prefix: PLAT ID: 0131

**User Response**

This is a UEFI detected event. The UEFI diagnostic code for this event can be found in the logged IMM message text. Please refer to the UEFI diagnostic code in the "UEFI diagnostic code" section of the Information Center for the appropriate user response.

**Related links**

– "Finding the UEFI diagnostic code" on page 776

- **806f040c-2022ffff : [PhysicalMemoryElementName] Disabled on Subsystem [MemoryElementName].**

Memory has been Disabled.

**Severity**

Info

**Serviceable**

No

**Automatically notify support**

No

**Alert Category**

System - Other

**SNMP Trap ID**

**CIM Information**

Prefix: PLAT ID: 0131

**User Response**

This is a UEFI detected event. The UEFI diagnostic code for this event can be found in the logged IMM message text. Please refer to the UEFI diagnostic code in the "UEFI diagnostic code" section of the Information Center for the appropriate user response.

**Related links**

– "Finding the UEFI diagnostic code" on page 776

- **806f040c-2023ffff : [PhysicalMemoryElementName] Disabled on Subsystem [MemoryElementName].**

Memory has been Disabled.

**Severity**

Info

**Serviceable**

No

**Automatically notify support**

No



**Alert Category**

System - Other

**SNMP Trap ID****CIM Information**

Prefix: PLAT ID: 0131

**User Response**

This is a UEFI detected event. The UEFI diagnostic code for this event can be found in the logged IMM message text. Please refer to the UEFI diagnostic code in the "UEFI diagnostic code" section of the Information Center for the appropriate user response.

**Related links**

- "Finding the UEFI diagnostic code" on page 776
- **806f040c-2024ffff : [PhysicalMemoryElementName] Disabled on Subsystem [MemoryElementName].**

Memory has been Disabled.

**Severity**

Info

**Serviceable**

No

**Automatically notify support**

No

**Alert Category**

System - Other

**SNMP Trap ID****CIM Information**

Prefix: PLAT ID: 0131

**User Response**

This is a UEFI detected event. The UEFI diagnostic code for this event can be found in the logged IMM message text. Please refer to the UEFI diagnostic code in the "UEFI diagnostic code" section of the Information Center for the appropriate user response.

**Related links**

- "Finding the UEFI diagnostic code" on page 776
- **806f040c-2025ffff : [PhysicalMemoryElementName] Disabled on Subsystem [MemoryElementName].**

Memory has been Disabled.

**Severity**

Info

**Serviceable**

No

**Automatically notify support**

No

**Alert Category**

System - Other

**SNMP Trap ID**

**CIM Information**

Prefix: PLAT ID: 0131

**User Response**

This is a UEFI detected event. The UEFI diagnostic code for this event can be found in the logged IMM message text. Please refer to the UEFI diagnostic code in the "UEFI diagnostic code" section of the Information Center for the appropriate user response.

**Related links**

– "Finding the UEFI diagnostic code" on page 776

- **806f040c-2026ffff : [PhysicalMemoryElementName] Disabled on Subsystem [MemoryElementName].**

Memory has been Disabled.

**Severity**

Info

**Serviceable**

No

**Automatically notify support**

No

**Alert Category**

System - Other

**SNMP Trap ID****CIM Information**

Prefix: PLAT ID: 0131

**User Response**

This is a UEFI detected event. The UEFI diagnostic code for this event can be found in the logged IMM message text. Please refer to the UEFI diagnostic code in the "UEFI diagnostic code" section of the Information Center for the appropriate user response.

**Related links**

– "Finding the UEFI diagnostic code" on page 776

- **806f040c-2027ffff : [PhysicalMemoryElementName] Disabled on Subsystem [MemoryElementName].**

Memory has been Disabled.

**Severity**

Info

**Serviceable**

No

**Automatically notify support**

No

**Alert Category**

System - Other

**SNMP Trap ID****CIM Information**

Prefix: PLAT ID: 0131

**User Response**

This is a UEFI detected event. The UEFI diagnostic code for this event can be found in the logged IMM message text. Please refer to the UEFI diagnostic code in the "UEFI diagnostic code" section of the Information Center for the appropriate user response.

**Related links**

- "Finding the UEFI diagnostic code" on page 776
- **806f040c-2028ffff : [PhysicalMemoryElementName] Disabled on Subsystem [MemoryElementName].**

Memory has been Disabled.

**Severity**

Info

**Serviceable**

No

**Automatically notify support**

No

**Alert Category**

System - Other

**SNMP Trap ID****CIM Information**

Prefix: PLAT ID: 0131

**User Response**

This is a UEFI detected event. The UEFI diagnostic code for this event can be found in the logged IMM message text. Please refer to the UEFI diagnostic code in the "UEFI diagnostic code" section of the Information Center for the appropriate user response.

**Related links**

- "Finding the UEFI diagnostic code" on page 776
- **806f040c-2029ffff : [PhysicalMemoryElementName] Disabled on Subsystem [MemoryElementName].**

Memory has been Disabled.

**Severity**

Info

**Serviceable**

No

**Automatically notify support**

No

**Alert Category**

System - Other

**SNMP Trap ID****CIM Information**

Prefix: PLAT ID: 0131

**User Response**

This is a UEFI detected event. The UEFI diagnostic code for this event can be found in the logged IMM message text. Please refer to the UEFI diagnostic code in the "UEFI diagnostic code" section of the Information Center for the appropriate user response.

**Related links**

– “Finding the UEFI diagnostic code” on page 776

- **806f040c-202affff : [PhysicalMemoryElementName] Disabled on Subsystem [MemoryElementName].**

Memory has been Disabled.

**Severity**

Info

**Serviceable**

No

**Automatically notify support**

No

**Alert Category**

System - Other

**SNMP Trap ID****CIM Information**

Prefix: PLAT ID: 0131

**User Response**

This is a UEFI detected event. The UEFI diagnostic code for this event can be found in the logged IMM message text. Please refer to the UEFI diagnostic code in the "UEFI diagnostic code" section of the Information Center for the appropriate user response.

**Related links**

– “Finding the UEFI diagnostic code” on page 776

- **806f040c-202bffff : [PhysicalMemoryElementName] Disabled on Subsystem [MemoryElementName].**

Memory has been Disabled.

**Severity**

Info

**Serviceable**

No

**Automatically notify support**

No

**Alert Category**

System - Other

**SNMP Trap ID****CIM Information**

Prefix: PLAT ID: 0131

**User Response**

This is a UEFI detected event. The UEFI diagnostic code for this event can be found in the logged IMM message text. Please refer to the UEFI diagnostic code in the "UEFI diagnostic code" section of the Information Center for the appropriate user response.

**Related links**

– “Finding the UEFI diagnostic code” on page 776

- **806f040c-202cffff : [PhysicalMemoryElementName] Disabled on Subsystem [MemoryElementName].**

Memory has been Disabled.

**Severity**

Info

**Serviceable**

No

**Automatically notify support**

No

**Alert Category**

System - Other

**SNMP Trap ID****CIM Information**

Prefix: PLAT ID: 0131

**User Response**

This is a UEFI detected event. The UEFI diagnostic code for this event can be found in the logged IMM message text. Please refer to the UEFI diagnostic code in the "UEFI diagnostic code" section of the Information Center for the appropriate user response.

**Related links**

– “Finding the UEFI diagnostic code” on page 776

- **806f040c-202dffff : [PhysicalMemoryElementName] Disabled on Subsystem [MemoryElementName].**

Memory has been Disabled.

**Severity**

Info

**Serviceable**

No

**Automatically notify support**

No

**Alert Category**

System - Other

**SNMP Trap ID****CIM Information**

Prefix: PLAT ID: 0131

**User Response**

This is a UEFI detected event. The UEFI diagnostic code for this event can be found in the logged IMM message text. Please refer to the UEFI diagnostic code in the "UEFI diagnostic code" section of the Information Center for the appropriate user response.

**Related links**

– “Finding the UEFI diagnostic code” on page 776

- **806f040c-202effff : [PhysicalMemoryElementName] Disabled on Subsystem [MemoryElementName].**

Memory has been Disabled.

**Severity**

Info

**Serviceable**

No

**Automatically notify support**

No

**Alert Category**

System - Other

**SNMP Trap ID**

**CIM Information**

Prefix: PLAT ID: 0131

**User Response**

This is a UEFI detected event. The UEFI diagnostic code for this event can be found in the logged IMM message text. Please refer to the UEFI diagnostic code in the "UEFI diagnostic code" section of the Information Center for the appropriate user response.

**Related links**

– "Finding the UEFI diagnostic code" on page 776

- **806f040c-202fffff : [PhysicalMemoryElementName] Disabled on Subsystem [MemoryElementName].**

Memory has been Disabled.

**Severity**

Info

**Serviceable**

No

**Automatically notify support**

No

**Alert Category**

System - Other

**SNMP Trap ID**

**CIM Information**

Prefix: PLAT ID: 0131

**User Response**

This is a UEFI detected event. The UEFI diagnostic code for this event can be found in the logged IMM message text. Please refer to the UEFI diagnostic code in the "UEFI diagnostic code" section of the Information Center for the appropriate user response.

**Related links**

– "Finding the UEFI diagnostic code" on page 776

- **806f040c-2030ffff : [PhysicalMemoryElementName] Disabled on Subsystem [MemoryElementName].**

Memory has been Disabled.

**Severity**

Info

**Serviceable**

No

**Automatically notify support**

No

**Alert Category**

System - Other

**SNMP Trap ID****CIM Information****Prefix:** PLAT ID: 0131**User Response**

This is a UEFI detected event. The UEFI diagnostic code for this event can be found in the logged IMM message text. Please refer to the UEFI diagnostic code in the "UEFI diagnostic code" section of the Information Center for the appropriate user response.

**Related links**

- "Finding the UEFI diagnostic code" on page 776
- **806f040c-2581ffff : [PhysicalMemoryElementName] Disabled on Subsystem [MemoryElementName].**

Memory has been disabled. All DIMMs. One of the DIMMs.

**Severity**

Info

**Serviceable**

No

**Automatically notify support**

No

**Alert Category**

System - Other

**SNMP Trap ID****CIM Information****Prefix:** PLAT ID: 0131**User Response**

This is a UEFI detected event. The UEFI diagnostic code for this event can be found in the logged IMM message text. Please refer to the UEFI diagnostic code in the "UEFI diagnostic code" section of the Information Center for the appropriate user response.

**Related links**

- "Finding the UEFI diagnostic code" on page 776
- **806f0413-2582ffff : A PCI PERR has occurred on system [ComputerSystemElementName].**

A PCI Parity Error (PERR) occurred on one of these sensors: All PCI Error, One of PCI Error.

**Severity**

Error

**Serviceable**

Yes

**Automatically notify support**

No

**Alert Category**

Critical - Other

**SNMP Trap ID**

50

**CIM Information**

**Prefix:** PLAT ID: 0232

**User Response**

This is a UEFI detected event. The UEFI diagnostic code for this event can be found in the logged IMM message text. Please refer to the UEFI diagnostic code in the "UEFI diagnostic code" section of the Information Center for the appropriate user response.

**Related links**

- "Finding the UEFI diagnostic code" on page 776
- **806f0507-0301ffff : CPU 1 has a Configuration Mismatch.**

A processor configuration mismatch has occurred.

**Severity**

Error

**Serviceable**

Yes

**Automatically notify support**

No

**Alert Category**

Critical - CPU

**SNMP Trap ID**

40

**CIM Information**

**Prefix:** PLAT ID: 0062

**User Response**

This is a UEFI detected event. The UEFI diagnostic code for this event can be found in the logged IMM message text. Please refer to the UEFI diagnostic code in the "UEFI diagnostic code" section of the Information Center for the appropriate user response.

**Related links**

- "Finding the UEFI diagnostic code" on page 776
- **806f0507-0302ffff : CPU 2 has a Configuration Mismatch.**

A Processor Configuration Mismatch has occurred.

**Severity**

Error

**Serviceable**

Yes

**Automatically notify support**

No

**Alert Category**

Critical - CPU



**SNMP Trap ID**

40

**CIM Information****Prefix:** PLAT ID: 0062**User Response**

This is a UEFI detected event. The UEFI diagnostic code for this event can be found in the logged IMM message text. Please refer to the UEFI diagnostic code in the "UEFI diagnostic code" section of the Information Center for the appropriate user response.

**Related links**

- "Finding the UEFI diagnostic code" on page 776
- **806f0507-0303ffff : CPU 3 has a Configuration Mismatch.**

A Processor Configuration Mismatch has occurred.

**Severity**

Error

**Serviceable**

Yes

**Automatically notify support**

No

**Alert Category**

Critical - CPU

**SNMP Trap ID**

40

**CIM Information****Prefix:** PLAT ID: 0062**User Response**

This is a UEFI detected event. The UEFI diagnostic code for this event can be found in the logged IMM message text. Please refer to the UEFI diagnostic code in the "UEFI diagnostic code" section of the Information Center for the appropriate user response.

**Related links**

- "Finding the UEFI diagnostic code" on page 776
- **806f0507-0304ffff : CPU 4 has a Configuration Mismatch.**

A Processor Configuration Mismatch has occurred.

**Severity**

Error

**Serviceable**

Yes

**Automatically notify support**

No

**Alert Category**

Critical - CPU

**SNMP Trap ID**

40

**CIM Information****Prefix:** PLAT ID: 0062

**User Response**

This is a UEFI detected event. The UEFI diagnostic code for this event can be found in the logged IMM message text. Please refer to the UEFI diagnostic code in the "UEFI diagnostic code" section of the Information Center for the appropriate user response.

**Related links**

- "Finding the UEFI diagnostic code" on page 776
- **806f0507-2584ffff : [ProcessorElementName] has a Configuration Mismatch.**

A processor configuration mismatch has occurred. All CPUs. One of CPUs.

**Severity**

Error

**Serviceable**

Yes

**Automatically notify support**

No

**Alert Category**

Critical - CPU

**SNMP Trap ID**

40

**CIM Information**

Prefix: PLAT ID: 0062

**User Response**

This is a UEFI detected event. The UEFI diagnostic code for this event can be found in the logged IMM message text. Please refer to the UEFI diagnostic code in the "UEFI diagnostic code" section of the Information Center for the appropriate user response.

**Related links**

- "Finding the UEFI diagnostic code" on page 776
- **806f050c-2001ffff : Memory Logging Limit Reached for [PhysicalMemoryElementName] on Subsystem [MemoryElementName].**

The Memory Logging Limit has been Reached.

**Severity**

Warning

**Serviceable**

Yes

**Automatically notify support**

Yes

**Alert Category**

Warning - Memory

**SNMP Trap ID**

43

**CIM Information**

Prefix: PLAT ID: 0144

**User Response**

This is a UEFI detected event. The UEFI diagnostic code for this event can be found in the logged IMM message text. Please refer to the UEFI diagnostic code in the "UEFI diagnostic code" section of the Information Center for the appropriate user response.

**Related links**

– “Finding the UEFI diagnostic code” on page 776

- **806f050c-2002ffff : Memory Logging Limit Reached for [PhysicalMemoryElementName] on Subsystem [MemoryElementName].**

The Memory Logging Limit has been Reached.

**Severity**

Warning

**Serviceable**

Yes

**Automatically notify support**

Yes

**Alert Category**

Warning - Memory

**SNMP Trap ID**

43

**CIM Information**

Prefix: PLAT ID: 0144

**User Response**

This is a UEFI detected event. The UEFI diagnostic code for this event can be found in the logged IMM message text. Please refer to the UEFI diagnostic code in the "UEFI diagnostic code" section of the Information Center for the appropriate user response.

**Related links**

– “Finding the UEFI diagnostic code” on page 776

- **806f050c-2003ffff : Memory Logging Limit Reached for [PhysicalMemoryElementName] on Subsystem [MemoryElementName].**

The Memory Logging Limit has been Reached.

**Severity**

Warning

**Serviceable**

Yes

**Automatically notify support**

Yes

**Alert Category**

Warning - Memory

**SNMP Trap ID**

43

**CIM Information**

Prefix: PLAT ID: 0144

**User Response**

This is a UEFI detected event. The UEFI diagnostic code for this event can be found in the logged IMM message text. Please refer to the UEFI diagnostic code in the "UEFI diagnostic code" section of the Information Center for the appropriate user response.

**Related links**

– “Finding the UEFI diagnostic code” on page 776

- **806f050c-200401ff : Memory Logging Limit Reached for [PhysicalMemoryElementName] on Subsystem [MemoryElementName].**

The Memory Logging Limit has been Reached.

**Severity**

Warning

**Serviceable**

Yes

**Automatically notify support**

Yes

**Alert Category**

Warning - Memory

**SNMP Trap ID**

43

**CIM Information**

Prefix: PLAT ID: 0144

**User Response**

This is a UEFI detected event. The UEFI diagnostic code for this event can be found in the logged IMM message text. Please refer to the UEFI diagnostic code in the "UEFI diagnostic code" section of the Information Center for the appropriate user response.

**Related links**

- "Finding the UEFI diagnostic code" on page 776

- **806f050c-2004ffff : Memory Logging Limit Reached for [PhysicalMemoryElementName] on Subsystem [MemoryElementName].**

The Memory Logging Limit has been Reached.

**Severity**

Warning

**Serviceable**

Yes

**Automatically notify support**

Yes

**Alert Category**

Warning - Memory

**SNMP Trap ID**

43

**CIM Information**

Prefix: PLAT ID: 0144

**User Response**

This is a UEFI detected event. The UEFI diagnostic code for this event can be found in the logged IMM message text. Please refer to the UEFI diagnostic code in the "UEFI diagnostic code" section of the Information Center for the appropriate user response.

**Related links**

- "Finding the UEFI diagnostic code" on page 776

- **806f050c-2005ffff : Memory Logging Limit Reached for [PhysicalMemoryElementName] on Subsystem [MemoryElementName].**

The Memory Logging Limit has been Reached.

**Severity**

Warning

**Serviceable**

Yes

**Automatically notify support**

Yes

**Alert Category**

Warning - Memory

**SNMP Trap ID**

43

**CIM Information**

**Prefix:** PLAT ID: 0144

**User Response**

This is a UEFI detected event. The UEFI diagnostic code for this event can be found in the logged IMM message text. Please refer to the UEFI diagnostic code in the "UEFI diagnostic code" section of the Information Center for the appropriate user response.

**Related links**

- "Finding the UEFI diagnostic code" on page 776
- **806f050c-2006ffff : Memory Logging Limit Reached for [PhysicalMemoryElementName] on Subsystem [MemoryElementName].**

The Memory Logging Limit has been Reached.

**Severity**

Warning

**Serviceable**

Yes

**Automatically notify support**

Yes

**Alert Category**

Warning - Memory

**SNMP Trap ID**

43

**CIM Information**

**Prefix:** PLAT ID: 0144

**User Response**

This is a UEFI detected event. The UEFI diagnostic code for this event can be found in the logged IMM message text. Please refer to the UEFI diagnostic code in the "UEFI diagnostic code" section of the Information Center for the appropriate user response.

**Related links**

- "Finding the UEFI diagnostic code" on page 776
- **806f050c-2007ffff : Memory Logging Limit Reached for [PhysicalMemoryElementName] on Subsystem [MemoryElementName].**

The Memory Logging Limit has been Reached.

**Severity**

Warning

**Serviceable**

Yes

**Automatically notify support**

Yes

**Alert Category**

Warning - Memory

**SNMP Trap ID**

43

**CIM Information**

**Prefix:** PLAT ID: 0144

**User Response**

This is a UEFI detected event. The UEFI diagnostic code for this event can be found in the logged IMM message text. Please refer to the UEFI diagnostic code in the "UEFI diagnostic code" section of the Information Center for the appropriate user response.

**Related links**

– “Finding the UEFI diagnostic code” on page 776

- **806f050c-2008ffff : Memory Logging Limit Reached for [PhysicalMemoryElementName] on Subsystem [MemoryElementName].**

The Memory Logging Limit has been Reached.

**Severity**

Warning

**Serviceable**

Yes

**Automatically notify support**

Yes

**Alert Category**

Warning - Memory

**SNMP Trap ID**

43

**CIM Information**

**Prefix:** PLAT ID: 0144

**User Response**

This is a UEFI detected event. The UEFI diagnostic code for this event can be found in the logged IMM message text. Please refer to the UEFI diagnostic code in the "UEFI diagnostic code" section of the Information Center for the appropriate user response.

**Related links**

– “Finding the UEFI diagnostic code” on page 776

- **806f050c-200901ff : Memory Logging Limit Reached for [PhysicalMemoryElementName] on Subsystem [MemoryElementName].**

The Memory Logging Limit has been Reached.

**Severity**

Warning

**Serviceable**

Yes

**Automatically notify support**

Yes

**Alert Category**

Warning - Memory

**SNMP Trap ID**

43

**CIM Information**

**Prefix:** PLAT ID: 0144

**User Response**

This is a UEFI detected event. The UEFI diagnostic code for this event can be found in the logged IMM message text. Please refer to the UEFI diagnostic code in the "UEFI diagnostic code" section of the Information Center for the appropriate user response.

**Related links**

- "Finding the UEFI diagnostic code" on page 776
- **806f050c-2009ffff : Memory Logging Limit Reached for [PhysicalMemoryElementName] on Subsystem [MemoryElementName].**

The Memory Logging Limit has been Reached.

**Severity**

Warning

**Serviceable**

Yes

**Automatically notify support**

Yes

**Alert Category**

Warning - Memory

**SNMP Trap ID**

43

**CIM Information**

**Prefix:** PLAT ID: 0144

**User Response**

This is a UEFI detected event. The UEFI diagnostic code for this event can be found in the logged IMM message text. Please refer to the UEFI diagnostic code in the "UEFI diagnostic code" section of the Information Center for the appropriate user response.

**Related links**

- "Finding the UEFI diagnostic code" on page 776
- **806f050c-200affff : Memory Logging Limit Reached for [PhysicalMemoryElementName] on Subsystem [MemoryElementName].**

The Memory Logging Limit has been Reached.

**Severity**

Warning

**Serviceable**

Yes

**Automatically notify support**

Yes

**Alert Category**

Warning - Memory

**SNMP Trap ID**

**CIM Information****Prefix:** PLAT ID: 0144**User Response**

This is a UEFI detected event. The UEFI diagnostic code for this event can be found in the logged IMM message text. Please refer to the UEFI diagnostic code in the "UEFI diagnostic code" section of the Information Center for the appropriate user response.

**Related links**

- "Finding the UEFI diagnostic code" on page 776
- **806f050c-200bffff : Memory Logging Limit Reached for [PhysicalMemoryElementName] on Subsystem [MemoryElementName].**

The Memory Logging Limit has been Reached.

**Severity**

Warning

**Serviceable**

Yes

**Automatically notify support**

Yes

**Alert Category**

Warning - Memory

**SNMP Trap ID**

43

**CIM Information****Prefix:** PLAT ID: 0144**User Response**

This is a UEFI detected event. The UEFI diagnostic code for this event can be found in the logged IMM message text. Please refer to the UEFI diagnostic code in the "UEFI diagnostic code" section of the Information Center for the appropriate user response.

**Related links**

- "Finding the UEFI diagnostic code" on page 776
- **806f050c-200cffff : Memory Logging Limit Reached for [PhysicalMemoryElementName] on Subsystem [MemoryElementName].**

The Memory Logging Limit has been Reached.

**Severity**

Warning

**Serviceable**

Yes

**Automatically notify support**

Yes

**Alert Category**

Warning - Memory

**SNMP Trap ID**

43

**CIM Information****Prefix:** PLAT ID: 0144



**User Response**

This is a UEFI detected event. The UEFI diagnostic code for this event can be found in the logged IMM message text. Please refer to the UEFI diagnostic code in the "UEFI diagnostic code" section of the Information Center for the appropriate user response.

**Related links**

- "Finding the UEFI diagnostic code" on page 776
- **806f050c-200dffff : Memory Logging Limit Reached for [PhysicalMemoryElementName] on Subsystem [MemoryElementName].**

The Memory Logging Limit has been Reached.

**Severity**

Warning

**Serviceable**

Yes

**Automatically notify support**

Yes

**Alert Category**

Warning - Memory

**SNMP Trap ID**

43

**CIM Information**

**Prefix:** PLAT ID: 0144

**User Response**

This is a UEFI detected event. The UEFI diagnostic code for this event can be found in the logged IMM message text. Please refer to the UEFI diagnostic code in the "UEFI diagnostic code" section of the Information Center for the appropriate user response.

**Related links**

- "Finding the UEFI diagnostic code" on page 776
- **806f050c-200effff : Memory Logging Limit Reached for [PhysicalMemoryElementName] on Subsystem [MemoryElementName].**

The Memory Logging Limit has been Reached.

**Severity**

Warning

**Serviceable**

Yes

**Automatically notify support**

Yes

**Alert Category**

Warning - Memory

**SNMP Trap ID**

43

**CIM Information**

**Prefix:** PLAT ID: 0144

**User Response**

This is a UEFI detected event. The UEFI diagnostic code for this event can be found in the logged IMM message text. Please refer to the UEFI diagnostic code in the "UEFI diagnostic code" section of the Information Center for the appropriate user response.

**Related links**

– “Finding the UEFI diagnostic code” on page 776

- **806f050c-200ffff : Memory Logging Limit Reached for [PhysicalMemoryElementName] on Subsystem [MemoryElementName].**

The Memory Logging Limit has been Reached.

**Severity**

Warning

**Serviceable**

Yes

**Automatically notify support**

Yes

**Alert Category**

Warning - Memory

**SNMP Trap ID**

43

**CIM Information**

**Prefix: PLAT ID: 0144**

**User Response**

This is a UEFI detected event. The UEFI diagnostic code for this event can be found in the logged IMM message text. Please refer to the UEFI diagnostic code in the "UEFI diagnostic code" section of the Information Center for the appropriate user response.

**Related links**

– “Finding the UEFI diagnostic code” on page 776

- **806f050c-2010ffff : Memory Logging Limit Reached for [PhysicalMemoryElementName] on Subsystem [MemoryElementName].**

The Memory Logging Limit has been Reached.

**Severity**

Warning

**Serviceable**

Yes

**Automatically notify support**

Yes

**Alert Category**

Warning - Memory

**SNMP Trap ID**

43

**CIM Information**

**Prefix: PLAT ID: 0144**

**User Response**

This is a UEFI detected event. The UEFI diagnostic code for this event can be found in the logged IMM message text. Please refer to the UEFI diagnostic code in the "UEFI diagnostic code" section of the Information Center for the appropriate user response.

**Related links**

– “Finding the UEFI diagnostic code” on page 776

- **806f050c-2011ffff : Memory Logging Limit Reached for [PhysicalMemoryElementName] on Subsystem [MemoryElementName].**

The Memory Logging Limit has been Reached.

**Severity**

Warning

**Serviceable**

Yes

**Automatically notify support**

Yes

**Alert Category**

Warning - Memory

**SNMP Trap ID**

43

**CIM Information**

Prefix: PLAT ID: 0144

**User Response**

This is a UEFI detected event. The UEFI diagnostic code for this event can be found in the logged IMM message text. Please refer to the UEFI diagnostic code in the "UEFI diagnostic code" section of the Information Center for the appropriate user response.

**Related links**

– “Finding the UEFI diagnostic code” on page 776

- **806f050c-2012ffff : Memory Logging Limit Reached for [PhysicalMemoryElementName] on Subsystem [MemoryElementName].**

The Memory Logging Limit has been Reached.

**Severity**

Warning

**Serviceable**

Yes

**Automatically notify support**

Yes

**Alert Category**

Warning - Memory

**SNMP Trap ID**

43

**CIM Information**

Prefix: PLAT ID: 0144

**User Response**

This is a UEFI detected event. The UEFI diagnostic code for this event can be found in the logged IMM message text. Please refer to the UEFI diagnostic code in the "UEFI diagnostic code" section of the Information Center for the appropriate user response.

**Related links**

– “Finding the UEFI diagnostic code” on page 776

- **806f050c-2013ffff : Memory Logging Limit Reached for [PhysicalMemoryElementName] on Subsystem [MemoryElementName].**

The Memory Logging Limit has been Reached.

**Severity**

Warning

**Serviceable**

Yes

**Automatically notify support**

Yes

**Alert Category**

Warning - Memory

**SNMP Trap ID**

43

**CIM Information**

Prefix: PLAT ID: 0144

**User Response**

This is a UEFI detected event. The UEFI diagnostic code for this event can be found in the logged IMM message text. Please refer to the UEFI diagnostic code in the "UEFI diagnostic code" section of the Information Center for the appropriate user response.

**Related links**

- "Finding the UEFI diagnostic code" on page 776

- **806f050c-2014ffff : Memory Logging Limit Reached for [PhysicalMemoryElementName] on Subsystem [MemoryElementName].**

the Memory Logging Limit has been Reached.

**Severity**

Warning

**Serviceable**

Yes

**Automatically notify support**

Yes

**Alert Category**

Warning - Memory

**SNMP Trap ID**

43

**CIM Information**

Prefix: PLAT ID: 0144

**User Response**

This is a UEFI detected event. The UEFI diagnostic code for this event can be found in the logged IMM message text. Please refer to the UEFI diagnostic code in the "UEFI diagnostic code" section of the Information Center for the appropriate user response.

**Related links**

- "Finding the UEFI diagnostic code" on page 776

- **806f050c-2015ffff : Memory Logging Limit Reached for [PhysicalMemoryElementName] on Subsystem [MemoryElementName].**

The Memory Logging Limit has been Reached.

**Severity**

Warning

**Serviceable**

Yes

**Automatically notify support**

Yes

**Alert Category**

Warning - Memory

**SNMP Trap ID**

43

**CIM Information**

**Prefix:** PLAT ID: 0144

**User Response**

This is a UEFI detected event. The UEFI diagnostic code for this event can be found in the logged IMM message text. Please refer to the UEFI diagnostic code in the "UEFI diagnostic code" section of the Information Center for the appropriate user response.

**Related links**

- "Finding the UEFI diagnostic code" on page 776
- **806f050c-2016ffff : Memory Logging Limit Reached for [PhysicalMemoryElementName] on Subsystem [MemoryElementName].**

The Memory Logging Limit has been Reached.

**Severity**

Warning

**Serviceable**

Yes

**Automatically notify support**

Yes

**Alert Category**

Warning - Memory

**SNMP Trap ID**

43

**CIM Information**

**Prefix:** PLAT ID: 0144

**User Response**

This is a UEFI detected event. The UEFI diagnostic code for this event can be found in the logged IMM message text. Please refer to the UEFI diagnostic code in the "UEFI diagnostic code" section of the Information Center for the appropriate user response.

**Related links**

- "Finding the UEFI diagnostic code" on page 776
- **806f050c-2017ffff : Memory Logging Limit Reached for [PhysicalMemoryElementName] on Subsystem [MemoryElementName].**

The Memory Logging Limit has been Reached.

**Severity**

Warning

**Serviceable**

Yes

**Automatically notify support**

Yes

**Alert Category**

Warning - Memory

**SNMP Trap ID**

43

**CIM Information**

**Prefix:** PLAT ID: 0144

**User Response**

This is a UEFI detected event. The UEFI diagnostic code for this event can be found in the logged IMM message text. Please refer to the UEFI diagnostic code in the "UEFI diagnostic code" section of the Information Center for the appropriate user response.

**Related links**

– "Finding the UEFI diagnostic code" on page 776

- **806f050c-2018ffff : Memory Logging Limit Reached for [PhysicalMemoryElementName] on Subsystem [MemoryElementName].**

The Memory Logging Limit has been Reached.

**Severity**

Warning

**Serviceable**

Yes

**Automatically notify support**

Yes

**Alert Category**

Warning - Memory

**SNMP Trap ID**

43

**CIM Information**

**Prefix:** PLAT ID: 0144

**User Response**

This is a UEFI detected event. The UEFI diagnostic code for this event can be found in the logged IMM message text. Please refer to the UEFI diagnostic code in the "UEFI diagnostic code" section of the Information Center for the appropriate user response.

**Related links**

– "Finding the UEFI diagnostic code" on page 776

- **806f050c-2019ffff : Memory Logging Limit Reached for [PhysicalMemoryElementName] on Subsystem [MemoryElementName].**

The Memory Logging Limit has been Reached.

**Severity**

Warning

**Serviceable**

Yes

**Automatically notify support**

Yes

**Alert Category**

Warning - Memory

**SNMP Trap ID**

43

**CIM Information**

**Prefix:** PLAT ID: 0144

**User Response**

This is a UEFI detected event. The UEFI diagnostic code for this event can be found in the logged IMM message text. Please refer to the UEFI diagnostic code in the "UEFI diagnostic code" section of the Information Center for the appropriate user response.

**Related links**

- "Finding the UEFI diagnostic code" on page 776
- **806f050c-201affff : Memory Logging Limit Reached for [PhysicalMemoryElementName] on Subsystem [MemoryElementName].**

The Memory Logging Limit has been Reached.

**Severity**

Warning

**Serviceable**

Yes

**Automatically notify support**

Yes

**Alert Category**

Warning - Memory

**SNMP Trap ID**

43

**CIM Information**

**Prefix:** PLAT ID: 0144

**User Response**

This is a UEFI detected event. The UEFI diagnostic code for this event can be found in the logged IMM message text. Please refer to the UEFI diagnostic code in the "UEFI diagnostic code" section of the Information Center for the appropriate user response.

**Related links**

- "Finding the UEFI diagnostic code" on page 776
- **806f050c-201bffff : Memory Logging Limit Reached for [PhysicalMemoryElementName] on Subsystem [MemoryElementName].**

The Memory Logging Limit has been Reached.

**Severity**

Warning

**Serviceable**

Yes

**Automatically notify support**

Yes

**Alert Category**

Warning - Memory

**SNMP Trap ID**

**CIM Information**

Prefix: PLAT ID: 0144

**User Response**

This is a UEFI detected event. The UEFI diagnostic code for this event can be found in the logged IMM message text. Please refer to the UEFI diagnostic code in the "UEFI diagnostic code" section of the Information Center for the appropriate user response.

**Related links**

– “Finding the UEFI diagnostic code” on page 776

- **806f050c-201cffff : Memory Logging Limit Reached for [PhysicalMemoryElementName] on Subsystem [MemoryElementName].**

The Memory Logging Limit has been Reached.

**Severity**

Warning

**Serviceable**

Yes

**Automatically notify support**

Yes

**Alert Category**

Warning - Memory

**SNMP Trap ID**

43

**CIM Information**

Prefix: PLAT ID: 0144

**User Response**

This is a UEFI detected event. The UEFI diagnostic code for this event can be found in the logged IMM message text. Please refer to the UEFI diagnostic code in the "UEFI diagnostic code" section of the Information Center for the appropriate user response.

**Related links**

– “Finding the UEFI diagnostic code” on page 776

- **806f050c-201dffff : Memory Logging Limit Reached for [PhysicalMemoryElementName] on Subsystem [MemoryElementName].**

The Memory Logging Limit has been Reached.

**Severity**

Warning

**Serviceable**

Yes

**Automatically notify support**

Yes

**Alert Category**

Warning - Memory

**SNMP Trap ID**

43

**CIM Information**

Prefix: PLAT ID: 0144



**User Response**

This is a UEFI detected event. The UEFI diagnostic code for this event can be found in the logged IMM message text. Please refer to the UEFI diagnostic code in the "UEFI diagnostic code" section of the Information Center for the appropriate user response.

**Related links**

- "Finding the UEFI diagnostic code" on page 776
- **806f050c-201effff : Memory Logging Limit Reached for [PhysicalMemoryElementName] on Subsystem [MemoryElementName].**

The Memory Logging Limit has been Reached.

**Severity**

Warning

**Serviceable**

Yes

**Automatically notify support**

Yes

**Alert Category**

Warning - Memory

**SNMP Trap ID**

43

**CIM Information**

**Prefix:** PLAT ID: 0144

**User Response**

This is a UEFI detected event. The UEFI diagnostic code for this event can be found in the logged IMM message text. Please refer to the UEFI diagnostic code in the "UEFI diagnostic code" section of the Information Center for the appropriate user response.

**Related links**

- "Finding the UEFI diagnostic code" on page 776
- **806f050c-201ffff : Memory Logging Limit Reached for [PhysicalMemoryElementName] on Subsystem [MemoryElementName].**

The Memory Logging Limit has been Reached.

**Severity**

Warning

**Serviceable**

Yes

**Automatically notify support**

Yes

**Alert Category**

Warning - Memory

**SNMP Trap ID**

43

**CIM Information**

**Prefix:** PLAT ID: 0144

**User Response**

This is a UEFI detected event. The UEFI diagnostic code for this event can be found in the logged IMM message text. Please refer to the UEFI diagnostic code in the "UEFI diagnostic code" section of the Information Center for the appropriate user response.

**Related links**

- "Finding the UEFI diagnostic code" on page 776
- **806f050c-2020ffff : Memory Logging Limit Reached for [PhysicalMemoryElementName] on Subsystem [MemoryElementName].**

The Memory Logging Limit has been Reached.

**Severity**

Warning

**Serviceable**

Yes

**Automatically notify support**

Yes

**Alert Category**

Warning - Memory

**SNMP Trap ID**

43

**CIM Information**

**Prefix: PLAT ID:** 0144

**User Response**

This is a UEFI detected event. The UEFI diagnostic code for this event can be found in the logged IMM message text. Please refer to the UEFI diagnostic code in the "UEFI diagnostic code" section of the Information Center for the appropriate user response.

**Related links**

- "Finding the UEFI diagnostic code" on page 776
- **806f050c-2021ffff : Memory Logging Limit Reached for [PhysicalMemoryElementName] on Subsystem [MemoryElementName].**

The Memory Logging Limit has been Reached.

**Severity**

Warning

**Serviceable**

Yes

**Automatically notify support**

Yes

**Alert Category**

Warning - Memory

**SNMP Trap ID**

43

**CIM Information**

**Prefix: PLAT ID:** 0144

**User Response**

This is a UEFI detected event. The UEFI diagnostic code for this event can be found in the logged IMM message text. Please refer to the UEFI diagnostic code in the "UEFI diagnostic code" section of the Information Center for the appropriate user response.

**Related links**

– “Finding the UEFI diagnostic code” on page 776

- **806f050c-2022ffff : Memory Logging Limit Reached for [PhysicalMemoryElementName] on Subsystem [MemoryElementName].**

The Memory Logging Limit has been Reached.

**Severity**

Warning

**Serviceable**

Yes

**Automatically notify support**

Yes

**Alert Category**

Warning - Memory

**SNMP Trap ID**

43

**CIM Information**

Prefix: PLAT ID: 0144

**User Response**

This is a UEFI detected event. The UEFI diagnostic code for this event can be found in the logged IMM message text. Please refer to the UEFI diagnostic code in the "UEFI diagnostic code" section of the Information Center for the appropriate user response.

**Related links**

– “Finding the UEFI diagnostic code” on page 776

- **806f050c-2023ffff : Memory Logging Limit Reached for [PhysicalMemoryElementName] on Subsystem [MemoryElementName].**

The Memory Logging Limit has been Reached.

**Severity**

Warning

**Serviceable**

Yes

**Automatically notify support**

Yes

**Alert Category**

Warning - Memory

**SNMP Trap ID**

43

**CIM Information**

Prefix: PLAT ID: 0144

**User Response**

This is a UEFI detected event. The UEFI diagnostic code for this event can be found in the logged IMM message text. Please refer to the UEFI diagnostic code in the "UEFI diagnostic code" section of the Information Center for the appropriate user response.

**Related links**

– “Finding the UEFI diagnostic code” on page 776

- **806f050c-2024ffff : Memory Logging Limit Reached for [PhysicalMemoryElementName] on Subsystem [MemoryElementName].**

The Memory Logging Limit has been Reached.

**Severity**

Warning

**Serviceable**

Yes

**Automatically notify support**

Yes

**Alert Category**

Warning - Memory

**SNMP Trap ID**

43

**CIM Information**

Prefix: PLAT ID: 0144

**User Response**

This is a UEFI detected event. The UEFI diagnostic code for this event can be found in the logged IMM message text. Please refer to the UEFI diagnostic code in the "UEFI diagnostic code" section of the Information Center for the appropriate user response.

**Related links**

– “Finding the UEFI diagnostic code” on page 776

- **806f050c-2025ffff : Memory Logging Limit Reached for [PhysicalMemoryElementName] on Subsystem [MemoryElementName].**

The Memory Logging Limit has been Reached.

**Severity**

Warning

**Serviceable**

Yes

**Automatically notify support**

Yes

**Alert Category**

Warning - Memory

**SNMP Trap ID**

43

**CIM Information**

Prefix: PLAT ID: 0144

**User Response**

This is a UEFI detected event. The UEFI diagnostic code for this event can be found in the logged IMM message text. Please refer to the UEFI diagnostic code in the "UEFI diagnostic code" section of the Information Center for the appropriate user response.

**Related links**

– “Finding the UEFI diagnostic code” on page 776

- **806f050c-2026ffff : Memory Logging Limit Reached for [PhysicalMemoryElementName] on Subsystem [MemoryElementName].**

The Memory Logging Limit has been Reached.

**Severity**

Warning

**Serviceable**

Yes

**Automatically notify support**

Yes

**Alert Category**

Warning - Memory

**SNMP Trap ID**

43

**CIM Information**

**Prefix:** PLAT ID: 0144

**User Response**

This is a UEFI detected event. The UEFI diagnostic code for this event can be found in the logged IMM message text. Please refer to the UEFI diagnostic code in the "UEFI diagnostic code" section of the Information Center for the appropriate user response.

**Related links**

- "Finding the UEFI diagnostic code" on page 776
- **806f050c-202702ff : Memory Logging Limit Reached for [PhysicalMemoryElementName] on Subsystem [MemoryElementName].**

The Memory Logging Limit has been Reached.

**Severity**

Warning

**Serviceable**

Yes

**Automatically notify support**

Yes

**Alert Category**

Warning - Memory

**SNMP Trap ID**

43

**CIM Information**

**Prefix:** PLAT ID: 0144

**User Response**

This is a UEFI detected event. The UEFI diagnostic code for this event can be found in the logged IMM message text. Please refer to the UEFI diagnostic code in the "UEFI diagnostic code" section of the Information Center for the appropriate user response.

**Related links**

- "Finding the UEFI diagnostic code" on page 776
- **806f050c-2027ffff : Memory Logging Limit Reached for [PhysicalMemoryElementName] on Subsystem [MemoryElementName].**

The Memory Logging Limit has been Reached.

**Severity**

Warning

**Serviceable**

Yes

**Automatically notify support**

Yes

**Alert Category**

Warning - Memory

**SNMP Trap ID**

43

**CIM Information**

**Prefix:** PLAT ID: 0144

**User Response**

This is a UEFI detected event. The UEFI diagnostic code for this event can be found in the logged IMM message text. Please refer to the UEFI diagnostic code in the "UEFI diagnostic code" section of the Information Center for the appropriate user response.

**Related links**

– "Finding the UEFI diagnostic code" on page 776

- **806f050c-2028ffff : Memory Logging Limit Reached for [PhysicalMemoryElementName] on Subsystem [MemoryElementName].**

The Memory Logging Limit has been Reached.

**Severity**

Warning

**Serviceable**

Yes

**Automatically notify support**

Yes

**Alert Category**

Warning - Memory

**SNMP Trap ID**

43

**CIM Information**

**Prefix:** PLAT ID: 0144

**User Response**

This is a UEFI detected event. The UEFI diagnostic code for this event can be found in the logged IMM message text. Please refer to the UEFI diagnostic code in the "UEFI diagnostic code" section of the Information Center for the appropriate user response.

**Related links**

– "Finding the UEFI diagnostic code" on page 776

- **806f050c-2029ffff : Memory Logging Limit Reached for [PhysicalMemoryElementName] on Subsystem [MemoryElementName].**

The Memory Logging Limit has been Reached.

**Severity**

Warning

**Serviceable**

Yes

**Automatically notify support**

Yes

**Alert Category**

Warning - Memory

**SNMP Trap ID**

43

**CIM Information**

**Prefix:** PLAT ID: 0144

**User Response**

This is a UEFI detected event. The UEFI diagnostic code for this event can be found in the logged IMM message text. Please refer to the UEFI diagnostic code in the "UEFI diagnostic code" section of the Information Center for the appropriate user response.

**Related links**

- "Finding the UEFI diagnostic code" on page 776
- **806f050c-202affff : Memory Logging Limit Reached for [PhysicalMemoryElementName] on Subsystem [MemoryElementName].**

the Memory Logging Limit has been Reached.

**Severity**

Warning

**Serviceable**

Yes

**Automatically notify support**

Yes

**Alert Category**

Warning - Memory

**SNMP Trap ID**

43

**CIM Information**

**Prefix:** PLAT ID: 0144

**User Response**

This is a UEFI detected event. The UEFI diagnostic code for this event can be found in the logged IMM message text. Please refer to the UEFI diagnostic code in the "UEFI diagnostic code" section of the Information Center for the appropriate user response.

**Related links**

- "Finding the UEFI diagnostic code" on page 776
- **806f050c-202bffff : Memory Logging Limit Reached for [PhysicalMemoryElementName] on Subsystem [MemoryElementName].**

The Memory Logging Limit has been Reached.

**Severity**

Warning

**Serviceable**

Yes

**Automatically notify support**

Yes

**Alert Category**

Warning - Memory

**SNMP Trap ID**

**CIM Information**

Prefix: PLAT ID: 0144

**User Response**

This is a UEFI detected event. The UEFI diagnostic code for this event can be found in the logged IMM message text. Please refer to the UEFI diagnostic code in the "UEFI diagnostic code" section of the Information Center for the appropriate user response.

**Related links**

– “Finding the UEFI diagnostic code” on page 776

- **806f050c-202cffff : Memory Logging Limit Reached for [PhysicalMemoryElementName] on Subsystem [MemoryElementName].**

The Memory Logging Limit has been Reached.

**Severity**

Warning

**Serviceable**

Yes

**Automatically notify support**

Yes

**Alert Category**

Warning - Memory

**SNMP Trap ID**

43

**CIM Information**

Prefix: PLAT ID: 0144

**User Response**

This is a UEFI detected event. The UEFI diagnostic code for this event can be found in the logged IMM message text. Please refer to the UEFI diagnostic code in the "UEFI diagnostic code" section of the Information Center for the appropriate user response.

**Related links**

– “Finding the UEFI diagnostic code” on page 776

- **806f050c-202dffff : Memory Logging Limit Reached for [PhysicalMemoryElementName] on Subsystem [MemoryElementName].**

The Memory Logging Limit has been Reached.

**Severity**

Warning

**Serviceable**

Yes

**Automatically notify support**

Yes

**Alert Category**

Warning - Memory

**SNMP Trap ID**

43

**CIM Information**

Prefix: PLAT ID: 0144



**User Response**

This is a UEFI detected event. The UEFI diagnostic code for this event can be found in the logged IMM message text. Please refer to the UEFI diagnostic code in the "UEFI diagnostic code" section of the Information Center for the appropriate user response.

**Related links**

- "Finding the UEFI diagnostic code" on page 776
- **806f050c-202effff : Memory Logging Limit Reached for [PhysicalMemoryElementName] on Subsystem [MemoryElementName].**

The Memory Logging Limit has been Reached.

**Severity**

Warning

**Serviceable**

Yes

**Automatically notify support**

Yes

**Alert Category**

Warning - Memory

**SNMP Trap ID**

43

**CIM Information**

**Prefix:** PLAT ID: 0144

**User Response**

This is a UEFI detected event. The UEFI diagnostic code for this event can be found in the logged IMM message text. Please refer to the UEFI diagnostic code in the "UEFI diagnostic code" section of the Information Center for the appropriate user response.

**Related links**

- "Finding the UEFI diagnostic code" on page 776
- **806f050c-202ffff : Memory Logging Limit Reached for [PhysicalMemoryElementName] on Subsystem [MemoryElementName].**

The Memory Logging Limit has been Reached.

**Severity**

Warning

**Serviceable**

Yes

**Automatically notify support**

Yes

**Alert Category**

Warning - Memory

**SNMP Trap ID**

43

**CIM Information**

**Prefix:** PLAT ID: 0144

**User Response**

This is a UEFI detected event. The UEFI diagnostic code for this event can be found in the logged IMM message text. Please refer to the UEFI diagnostic code in the "UEFI diagnostic code" section of the Information Center for the appropriate user response.

**Related links**

- "Finding the UEFI diagnostic code" on page 776
- **806f050c-2030ffff : Memory Logging Limit Reached for [PhysicalMemoryElementName] on Subsystem [MemoryElementName].**

The Memory Logging Limit has been Reached.

**Severity**

Warning

**Serviceable**

Yes

**Automatically notify support**

Yes

**Alert Category**

Warning - Memory

**SNMP Trap ID**

43

**CIM Information**

**Prefix: PLAT ID:** 0144

**User Response**

This is a UEFI detected event. The UEFI diagnostic code for this event can be found in the logged IMM message text. Please refer to the UEFI diagnostic code in the "UEFI diagnostic code" section of the Information Center for the appropriate user response.

**Related links**

- "Finding the UEFI diagnostic code" on page 776
- **806f050c-2581ffff : Memory Logging Limit Reached for [PhysicalMemoryElementName] on Subsystem [MemoryElementName].**

The memory logging limit has been reached. All DIMMs. One of the DIMMs.

**Severity**

Warning

**Serviceable**

Yes

**Automatically notify support**

Yes

**Alert Category**

Warning - Memory

**SNMP Trap ID**

43

**CIM Information**

**Prefix: PLAT ID:** 0144

**User Response**

This is a UEFI detected event. The UEFI diagnostic code for this event can be found in the logged IMM message text. Please refer to the UEFI diagnostic code in the "UEFI diagnostic code" section of the Information Center for the appropriate user response.

**Related links**

– “Finding the UEFI diagnostic code” on page 776

- **806f050d-0400ffff : Array [ComputerSystemElementName] is in critical condition.**

The RAID array is in critical condition. Immediate action is required to avoid a system outage.

**Severity**

Warning

**Serviceable**

Yes

**Automatically notify support**

No

**Alert Category**

Critical - Hard Disk drive

**SNMP Trap ID**

5

**CIM Information**

Prefix: PLAT ID: 0174

**User Response**

Replace the hard disk drive that is indicated by a lit status LED.

- **806f050d-0401ffff : Array [ComputerSystemElementName] is in critical condition.**

The RAID array is in critical condition. Immediate action is required to avoid a system outage.

**Severity**

Error

**Serviceable**

Yes

**Automatically notify support**

No

**Alert Category**

Critical - Hard Disk drive

**SNMP Trap ID**

5

**CIM Information**

Prefix: PLAT ID: 0174

**User Response**

Replace the hard disk drive that is indicated by a lit status LED.

- **806f050d-0402ffff : Array [ComputerSystemElementName] is in critical condition.**

The RAID array is in critical condition. Immediate action is required to avoid a system outage.

**Severity**

Error

**Serviceable**

Yes

**Automatically notify support**

No

**Alert Category**

Critical - Hard Disk drive

**SNMP Trap ID**

5

**CIM Information**

**Prefix: PLAT ID:** 0174

**User Response**

Replace the hard disk drive that is indicated by a lit status LED.

- **806f050d-0403ffff : Array [ComputerSystemElementName] is in critical condition.**

The RAID array is in critical condition. Immediate action is required to avoid a system outage.

**Severity**

Error

**Serviceable**

Yes

**Automatically notify support**

No

**Alert Category**

Critical - Hard Disk drive

**SNMP Trap ID**

5

**CIM Information**

**Prefix: PLAT ID:** 0174

**User Response**

Replace the hard disk drive that is indicated by a lit status LED.

- **806f050d-0404ffff : Array [ComputerSystemElementName] is in critical condition.**

The RAID array is in critical condition. Immediate action is required to avoid a system outage.

**Severity**

Error

**Serviceable**

Yes

**Automatically notify support**

No

**Alert Category**

Critical - Hard Disk drive

**SNMP Trap ID**

5

**CIM Information**

**Prefix: PLAT ID:** 0174

**User Response**

Replace the hard disk drive that is indicated by a lit status LED.

- **806f050d-0405ffff : Array [ComputerSystemElementName] is in critical condition.**

The RAID array is in critical condition. Immediate action is required to avoid a system outage.

**Severity**

Error

**Serviceable**

Yes

**Automatically notify support**

No

**Alert Category**

Critical - Hard Disk drive

**SNMP Trap ID**

5

**CIM Information**

Prefix: PLAT ID: 0174

**User Response**

Replace the hard disk drive that is indicated by a lit status LED.

- **806f050d-0406ffff : Array [ComputerSystemElementName] is in critical condition.**

The RAID array is in critical condition. Immediate action is required to avoid a system outage.

**Severity**

Error

**Serviceable**

Yes

**Automatically notify support**

No

**Alert Category**

Critical - Hard Disk drive

**SNMP Trap ID**

5

**CIM Information**

Prefix: PLAT ID: 0174

**User Response**

Replace the hard disk drive that is indicated by a lit status LED.

- **806f050d-0407ffff : Array [ComputerSystemElementName] is in critical condition.**

The RAID array is in critical condition. Immediate action is required to avoid a system outage.

**Severity**

Error

**Serviceable**

Yes

**Automatically notify support**

No

**Alert Category**

Critical - Hard Disk drive

**SNMP Trap ID**

5

**CIM Information**

Prefix: PLAT ID: 0174

**User Response**

Replace the hard disk drive that is indicated by a lit status LED.

- **806f0513-2582ffff : A PCI SERR has occurred on system [ComputerSystemElementName].**  
IMM has detected a PCI System Error (SERR) on one of these sensors: All PCI Error, One of PCI Error.

**Severity**

Error

**Serviceable**

Yes

**Automatically notify support**

No

**Alert Category**

Critical - Other

**SNMP Trap ID**

50

**CIM Information**

Prefix: PLAT ID: 0234

**User Response**

This is a UEFI detected event. The UEFI diagnostic code for this event can be found in the logged IMM message text. Please refer to the UEFI diagnostic code in the "UEFI diagnostic code" section of the Information Center for the appropriate user response.

**Related links**

- "Finding the UEFI diagnostic code" on page 776

- **806f052b-2101ffff : Invalid or Unsupported firmware or software was detected on system [ComputerSystemElementName].**

The IMM primary firmware image has been corrupted. The IMM is running on the backup image.

**Severity**

Error

**Serviceable**

Yes

**Automatically notify support**

No

**Alert Category**

Critical - Other

**SNMP Trap ID**

50

**CIM Information**

Prefix: PLAT ID: 0446

**User Response**

Reflash or update the IMM firmware.

- **806f0607-0301ffff : An SM BIOS Uncorrectable CPU complex error for CPU 1 has asserted.**

An SM BIOS Uncorrectable CPU complex error has asserted.

**Severity**

Error

**Serviceable**

Yes

**Automatically notify support**

No

**Alert Category**

Critical - CPU

**SNMP Trap ID**

40

**CIM Information**

**Prefix:** PLAT ID: 0816

**User Response**

This is a UEFI detected event. The UEFI diagnostic code for this event can be found in the logged IMM message text. Please refer to the UEFI diagnostic code in the "UEFI diagnostic code" section of the Information Center for the appropriate user response.

**Related links**

- "Finding the UEFI diagnostic code" on page 776
- **806f0607-0302ffff : An SM BIOS Uncorrectable CPU complex error for CPU 2 has asserted.**

An SM BIOS uncorrectable CPU complex error has asserted.

**Severity**

Error

**Serviceable**

Yes

**Automatically notify support**

No

**Alert Category**

Critical - CPU

**SNMP Trap ID**

40

**CIM Information**

**Prefix:** PLAT ID: 0816

**User Response**

This is a UEFI detected event. The UEFI diagnostic code for this event can be found in the logged IMM message text. Please refer to the UEFI diagnostic code in the "UEFI diagnostic code" section of the Information Center for the appropriate user response.

**Related links**

- "Finding the UEFI diagnostic code" on page 776
- **806f0607-0303ffff : An SM BIOS Uncorrectable CPU complex error for CPU 3 has asserted.**

An SM BIOS uncorrectable CPU complex error has asserted.

**Severity**

Error

**Serviceable**

Yes

**Automatically notify support**

No

**Alert Category**

Critical - CPU

**SNMP Trap ID**

40

**CIM Information****Prefix:** PLAT ID: 0816**User Response**

This is a UEFI detected event. The UEFI diagnostic code for this event can be found in the logged IMM message text. Please refer to the UEFI diagnostic code in the "UEFI diagnostic code" section of the Information Center for the appropriate user response.

**Related links**

– "Finding the UEFI diagnostic code" on page 776

- **806f0607-0304ffff : An SM BIOS Uncorrectable CPU complex error for CPU 4 has asserted.**

An SM BIOS uncorrectable CPU complex error has asserted.

**Severity**

Error

**Serviceable**

Yes

**Automatically notify support**

No

**Alert Category**

Critical - CPU

**SNMP Trap ID**

40

**CIM Information****Prefix:** PLAT ID: 0816**User Response**

This is a UEFI detected event. The UEFI diagnostic code for this event can be found in the logged IMM message text. Please refer to the UEFI diagnostic code in the "UEFI diagnostic code" section of the Information Center for the appropriate user response.

**Related links**

– "Finding the UEFI diagnostic code" on page 776

- **806f0607-2584ffff : An SM BIOS Uncorrectable CPU complex error for [ProcessorElementName] has asserted.**

An SM BIOS Uncorrectable CPU complex error has been detected. All CPUs. One of CPUs.

**Severity**

Error

**Serviceable**

Yes

**Automatically notify support**

No

**Alert Category**

Critical - CPU

**SNMP Trap ID**

40

**CIM Information****Prefix:** PLAT ID: 0816



**User Response**

This is a UEFI detected event. The UEFI diagnostic code for this event can be found in the logged IMM message text. Please refer to the UEFI diagnostic code in the "UEFI diagnostic code" section of the Information Center for the appropriate user response.

**Related links**

– “Finding the UEFI diagnostic code” on page 776

- **806f060d-0400ffff : Array [ComputerSystemElementName] has failed.**

The Drive 0 is part of an RAID array that is in the failed condition. To identify drives in the failed array all member drives will report this message.

**Severity**

Error

**Serviceable**

Yes

**Automatically notify support**

Yes

**Alert Category**

Critical - Hard Disk drive

**SNMP Trap ID**

5

**CIM Information**

Prefix: PLAT ID: 0176

**User Response**

- Replace the hard disk drives that are indicated by a lit status LED on the drive.
- Recreate the array.
- Restore data from backup.

- **806f060d-0401ffff : Array [ComputerSystemElementName] has failed.**

The Drive 1 is part of an RAID array that is in the failed condition. To identify drives in the failed array all member drives will report this message.

**Severity**

Error

**Serviceable**

Yes

**Automatically notify support**

Yes

**Alert Category**

Critical - Hard Disk drive

**SNMP Trap ID**

5

**CIM Information**

Prefix: PLAT ID: 0176

**User Response**

- Replace the hard disk drives that are indicated by a lit status LED on the drive.
- Recreate the array.
- Restore data from backup.

- **806f060d-0402ffff : Array [ComputerSystemElementName] has failed.**

The Drive 2 is part of an RAID array that is in the failed condition. To identify drives in the failed array all member drives will report this message.

**Severity**

Error

**Serviceable**

Yes

**Automatically notify support**

Yes

**Alert Category**

Critical - Hard Disk drive

**SNMP Trap ID**

5

**CIM Information**

**Prefix: PLAT ID:** 0176

**User Response**

- Replace the hard disk drives that are indicated by a lit status LED on the drive.
- Recreate the array.
- Restore data from backup.

• **806f060d-0403ffff : Array [ComputerSystemElementName] has failed.**

The Drive 3 is part of an RAID array that is in the failed condition. To identify drives in the failed array all member drives will report this message.

**Severity**

Error

**Serviceable**

Yes

**Automatically notify support**

Yes

**Alert Category**

Critical - Hard Disk drive

**SNMP Trap ID**

5

**CIM Information**

**Prefix: PLAT ID:** 0176

**User Response**

- Check IMM log for Predictive Fault (PFA) or other hard drive messages to help identify failing drive (s).
- Replace the hard disk drives that are indicated by a lit status LED on the drive.
- Recreate the array.
- Restore data from backup.

• **806f060d-0404ffff : Array [ComputerSystemElementName] has failed.**

The Drive 4 is part of an RAID array that is in the failed condition. To identify drives in the failed array all member drives will report this message.

**Severity**

Error

**Serviceable**

Yes

**Automatically notify support**

Yes

**Alert Category**

Critical - Hard Disk drive

**SNMP Trap ID**

5

**CIM Information**

**Prefix:** PLAT ID: 0176

**User Response**

- Replace the hard disk drives that are indicated by a lit status LED on the drive.
- Recreate the array.
- Restore data from backup.

• **806f060d-0405ffff : Array [ComputerSystemElementName] has failed.**

The Drive 5 is part of an RAID array that is in the failed condition. To identify drives in the failed array all member drives will report this message.

**Severity**

Error

**Serviceable**

Yes

**Automatically notify support**

Yes

**Alert Category**

Critical - Hard Disk drive

**SNMP Trap ID**

5

**CIM Information**

**Prefix:** PLAT ID: 0176

**User Response**

- Replace the hard disk drives that are indicated by a lit status LED on the drive.
- Recreate the array.
- Restore data from backup.

• **806f060d-0406ffff : Array [ComputerSystemElementName] has failed.**

The Drive 6 is part of an RAID array that is in the failed condition. To identify drives in the failed array all member drives will report this message.

**Severity**

Error

**Serviceable**

Yes

**Automatically notify support**

Yes

**Alert Category**

Critical - Hard Disk drive

**SNMP Trap ID**

5

**CIM Information**

Prefix: PLAT ID: 0176

**User Response**

- Replace the hard disk drives that are indicated by a lit status LED on the drive.
- Recreate the array.
- Restore data from backup.

- **806f060d-0407ffff : Array [ComputerSystemElementName] has failed.**

The Drive 7 is part of an RAID array that is in the failed condition. To identify drives in the failed array all member drives will report this message.

**Severity**

Error

**Serviceable**

Yes

**Automatically notify support**

Yes

**Alert Category**

Critical - Hard Disk drive

**SNMP Trap ID**

5

**CIM Information**

Prefix: PLAT ID: 0176

**User Response**

- Replace the hard disk drives that are indicated by a lit status LED on the drive.
- Recreate the array.
- Restore data from backup.

- **806f070c-2001ffff : Configuration Error for [PhysicalMemoryElementName] on Subsystem [MemoryElementName].**

A Memory DIMM configuration error has been detected.

**Severity**

Error

**Serviceable**

Yes

**Automatically notify support**

No

**Alert Category**

Critical - Memory

**SNMP Trap ID**

41

**CIM Information**

Prefix: PLAT ID: 0126

**User Response**

This is a UEFI detected event. The UEFI diagnostic code for this event can be found in the logged IMM message text. Please refer to the UEFI diagnostic code in the "UEFI diagnostic code" section of the Information Center for the appropriate user response.

**Related links**

- "Finding the UEFI diagnostic code" on page 776
- **806f070c-2002ffff : Configuration Error for [PhysicalMemoryElementName] on Subsystem [MemoryElementName].**

A Memory DIMM configuration error has been detected.

**Severity**

Error

**Serviceable**

Yes

**Automatically notify support**

No

**Alert Category**

Critical - Memory

**SNMP Trap ID**

41

**CIM Information**

Prefix: PLAT ID: 0126

**User Response**

This is a UEFI detected event. The UEFI diagnostic code for this event can be found in the logged IMM message text. Please refer to the UEFI diagnostic code in the "UEFI diagnostic code" section of the Information Center for the appropriate user response.

**Related links**

- "Finding the UEFI diagnostic code" on page 776
- **806f070c-2003ffff : Configuration Error for [PhysicalMemoryElementName] on Subsystem [MemoryElementName].**

A Memory DIMM configuration error has been detected.

**Severity**

Error

**Serviceable**

Yes

**Automatically notify support**

No

**Alert Category**

Critical - Memory

**SNMP Trap ID**

41

**CIM Information**

Prefix: PLAT ID: 0126

**User Response**

This is a UEFI detected event. The UEFI diagnostic code for this event can be found in the logged IMM message text. Please refer to the UEFI diagnostic code in the "UEFI diagnostic code" section of the Information Center for the appropriate user response.

**Related links**

- "Finding the UEFI diagnostic code" on page 776
- **806f070c-2004ffff : Configuration Error for [PhysicalMemoryElementName] on Subsystem [MemoryElementName].**

A Memory DIMM configuration error has been detected.

**Severity**

Error

**Serviceable**

Yes

**Automatically notify support**

No

**Alert Category**

Critical - Memory

**SNMP Trap ID**

41

**CIM Information**

**Prefix: PLAT ID:** 0126

**User Response**

This is a UEFI detected event. The UEFI diagnostic code for this event can be found in the logged IMM message text. Please refer to the UEFI diagnostic code in the "UEFI diagnostic code" section of the Information Center for the appropriate user response.

**Related links**

– “Finding the UEFI diagnostic code” on page 776

- **806f070c-2005ffff : Configuration Error for [PhysicalMemoryElementName] on Subsystem [MemoryElementName].**

A Memory DIMM configuration error has been detected.

**Severity**

Error

**Serviceable**

Yes

**Automatically notify support**

No

**Alert Category**

Critical - Memory

**SNMP Trap ID**

41

**CIM Information**

**Prefix: PLAT ID:** 0126

**User Response**

This is a UEFI detected event. The UEFI diagnostic code for this event can be found in the logged IMM message text. Please refer to the UEFI diagnostic code in the "UEFI diagnostic code" section of the Information Center for the appropriate user response.

**Related links**

– “Finding the UEFI diagnostic code” on page 776

- **806f070c-2006ffff : Configuration Error for [PhysicalMemoryElementName] on Subsystem [MemoryElementName].**

A Memory DIMM configuration error has been detected.

**Severity**

Error

**Serviceable**

Yes

**Automatically notify support**

No

**Alert Category**

Critical - Memory

**SNMP Trap ID**

41

**CIM Information**

**Prefix:** PLAT ID: 0126

**User Response**

This is a UEFI detected event. The UEFI diagnostic code for this event can be found in the logged IMM message text. Please refer to the UEFI diagnostic code in the "UEFI diagnostic code" section of the Information Center for the appropriate user response.

**Related links**

- "Finding the UEFI diagnostic code" on page 776
- **806f070c-2007ffff : Configuration Error for [PhysicalMemoryElementName] on Subsystem [MemoryElementName].**

A Memory DIMM configuration error has been detected.

**Severity**

Error

**Serviceable**

Yes

**Automatically notify support**

No

**Alert Category**

Critical - Memory

**SNMP Trap ID**

41

**CIM Information**

**Prefix:** PLAT ID: 0126

**User Response**

This is a UEFI detected event. The UEFI diagnostic code for this event can be found in the logged IMM message text. Please refer to the UEFI diagnostic code in the "UEFI diagnostic code" section of the Information Center for the appropriate user response.

**Related links**

- "Finding the UEFI diagnostic code" on page 776
- **806f070c-2008ffff : Configuration Error for [PhysicalMemoryElementName] on Subsystem [MemoryElementName].**

A Memory DIMM configuration error has been detected.

**Severity**

Error

**Serviceable**

Yes

**Automatically notify support**

No

**Alert Category**

Critical - Memory

**SNMP Trap ID**

41

**CIM Information**

Prefix: PLAT ID: 0126

**User Response**

This is a UEFI detected event. The UEFI diagnostic code for this event can be found in the logged IMM message text. Please refer to the UEFI diagnostic code in the "UEFI diagnostic code" section of the Information Center for the appropriate user response.

**Related links**

– “Finding the UEFI diagnostic code” on page 776

- **806f070c-2009ffff : Configuration Error for [PhysicalMemoryElementName] on Subsystem [MemoryElementName].**

A Memory DIMM configuration error has been detected.

**Severity**

Error

**Serviceable**

Yes

**Automatically notify support**

No

**Alert Category**

Critical - Memory

**SNMP Trap ID**

41

**CIM Information**

Prefix: PLAT ID: 0126

**User Response**

This is a UEFI detected event. The UEFI diagnostic code for this event can be found in the logged IMM message text. Please refer to the UEFI diagnostic code in the "UEFI diagnostic code" section of the Information Center for the appropriate user response.

**Related links**

– “Finding the UEFI diagnostic code” on page 776

- **806f070c-200affff : Configuration Error for [PhysicalMemoryElementName] on Subsystem [MemoryElementName].**

A Memory DIMM configuration error has been detected.

**Severity**

Error

**Serviceable**

Yes

**Automatically notify support**

No

**Alert Category**



Critical - Memory

**SNMP Trap ID**

41

**CIM Information**

**Prefix:** PLAT ID: 0126

**User Response**

This is a UEFI detected event. The UEFI diagnostic code for this event can be found in the logged IMM message text. Please refer to the UEFI diagnostic code in the "UEFI diagnostic code" section of the Information Center for the appropriate user response.

**Related links**

- "Finding the UEFI diagnostic code" on page 776
- **806f070c-200bffff : Configuration Error for [PhysicalMemoryElementName] on Subsystem [MemoryElementName].**

A Memory DIMM configuration error has been detected.

**Severity**

Error

**Serviceable**

Yes

**Automatically notify support**

No

**Alert Category**

Critical - Memory

**SNMP Trap ID**

41

**CIM Information**

**Prefix:** PLAT ID: 0126

**User Response**

This is a UEFI detected event. The UEFI diagnostic code for this event can be found in the logged IMM message text. Please refer to the UEFI diagnostic code in the "UEFI diagnostic code" section of the Information Center for the appropriate user response.

**Related links**

- "Finding the UEFI diagnostic code" on page 776
- **806f070c-200cffff : Configuration Error for [PhysicalMemoryElementName] on Subsystem [MemoryElementName].**

A Memory DIMM configuration error has been detected.

**Severity**

Error

**Serviceable**

Yes

**Automatically notify support**

No

**Alert Category**

Critical - Memory

**SNMP Trap ID**

41

**CIM Information**

Prefix: PLAT ID: 0126

**User Response**

This is a UEFI detected event. The UEFI diagnostic code for this event can be found in the logged IMM message text. Please refer to the UEFI diagnostic code in the "UEFI diagnostic code" section of the Information Center for the appropriate user response.

**Related links**

– "Finding the UEFI diagnostic code" on page 776

- **806f070c-200dffff : Configuration Error for [PhysicalMemoryElementName] on Subsystem [MemoryElementName].**

A Memory DIMM configuration error has been detected.

**Severity**

Error

**Serviceable**

Yes

**Automatically notify support**

No

**Alert Category**

Critical - Memory

**SNMP Trap ID**

41

**CIM Information**

Prefix: PLAT ID: 0126

**User Response**

This is a UEFI detected event. The UEFI diagnostic code for this event can be found in the logged IMM message text. Please refer to the UEFI diagnostic code in the "UEFI diagnostic code" section of the Information Center for the appropriate user response.

**Related links**

– "Finding the UEFI diagnostic code" on page 776

- **806f070c-200effff : Configuration Error for [PhysicalMemoryElementName] on Subsystem [MemoryElementName].**

A Memory DIMM configuration error has been detected.

**Severity**

Error

**Serviceable**

Yes

**Automatically notify support**

No

**Alert Category**

Critical - Memory

**SNMP Trap ID**

41

**CIM Information**

Prefix: PLAT ID: 0126

**User Response**

This is a UEFI detected event. The UEFI diagnostic code for this event can be found in the logged IMM message text. Please refer to the UEFI diagnostic code in the "UEFI diagnostic code" section of the Information Center for the appropriate user response.

**Related links**

- "Finding the UEFI diagnostic code" on page 776
- **806f070c-200ffff : Configuration Error for [PhysicalMemoryElementName] on Subsystem [MemoryElementName].**

A Memory DIMM configuration error has been detected.

**Severity**

Error

**Serviceable**

Yes

**Automatically notify support**

No

**Alert Category**

Critical - Memory

**SNMP Trap ID**

41

**CIM Information**

**Prefix:** PLAT ID: 0126

**User Response**

This is a UEFI detected event. The UEFI diagnostic code for this event can be found in the logged IMM message text. Please refer to the UEFI diagnostic code in the "UEFI diagnostic code" section of the Information Center for the appropriate user response.

**Related links**

- "Finding the UEFI diagnostic code" on page 776
- **806f070c-2010fff : Configuration Error for [PhysicalMemoryElementName] on Subsystem [MemoryElementName].**

A Memory DIMM configuration error has been detected.

**Severity**

Error

**Serviceable**

Yes

**Automatically notify support**

No

**Alert Category**

Critical - Memory

**SNMP Trap ID**

41

**CIM Information**

**Prefix:** PLAT ID: 0126

**User Response**

This is a UEFI detected event. The UEFI diagnostic code for this event can be found in the logged IMM message text. Please refer to the UEFI diagnostic code in the "UEFI diagnostic code" section of the Information Center for the appropriate user response.

**Related links**

– “Finding the UEFI diagnostic code” on page 776

- **806f070c-2011ffff : Configuration Error for [PhysicalMemoryElementName] on Subsystem [MemoryElementName].**

A Memory DIMM configuration error has been detected.

**Severity**

Error

**Serviceable**

Yes

**Automatically notify support**

No

**Alert Category**

Critical - Memory

**SNMP Trap ID**

41

**CIM Information**

**Prefix:** PLAT ID: 0126

**User Response**

This is a UEFI detected event. The UEFI diagnostic code for this event can be found in the logged IMM message text. Please refer to the UEFI diagnostic code in the "UEFI diagnostic code" section of the Information Center for the appropriate user response.

**Related links**

– “Finding the UEFI diagnostic code” on page 776

- **806f070c-2012ffff : Configuration Error for [PhysicalMemoryElementName] on Subsystem [MemoryElementName].**

A Memory DIMM configuration error has been detected.

**Severity**

Error

**Serviceable**

Yes

**Automatically notify support**

No

**Alert Category**

Critical - Memory

**SNMP Trap ID**

41

**CIM Information**

**Prefix:** PLAT ID: 0126

**User Response**

This is a UEFI detected event. The UEFI diagnostic code for this event can be found in the logged IMM message text. Please refer to the UEFI diagnostic code in the "UEFI diagnostic code" section of the Information Center for the appropriate user response.

**Related links**

– “Finding the UEFI diagnostic code” on page 776

- **806f070c-2013ffff : Configuration Error for [PhysicalMemoryElementName] on Subsystem [MemoryElementName].**

A Memory DIMM configuration error has been detected.

**Severity**

Error

**Serviceable**

Yes

**Automatically notify support**

No

**Alert Category**

Critical - Memory

**SNMP Trap ID**

41

**CIM Information**

Prefix: PLAT ID: 0126

**User Response**

This is a UEFI detected event. The UEFI diagnostic code for this event can be found in the logged IMM message text. Please refer to the UEFI diagnostic code in the "UEFI diagnostic code" section of the Information Center for the appropriate user response.

**Related links**

– “Finding the UEFI diagnostic code” on page 776

- **806f070c-2014ffff : Configuration Error for [PhysicalMemoryElementName] on Subsystem [MemoryElementName].**

A Memory DIMM configuration error has been detected.

**Severity**

Error

**Serviceable**

Yes

**Automatically notify support**

No

**Alert Category**

Critical - Memory

**SNMP Trap ID**

41

**CIM Information**

Prefix: PLAT ID: 0126

**User Response**

This is a UEFI detected event. The UEFI diagnostic code for this event can be found in the logged IMM message text. Please refer to the UEFI diagnostic code in the "UEFI diagnostic code" section of the Information Center for the appropriate user response.

**Related links**

– “Finding the UEFI diagnostic code” on page 776

- **806f070c-2015ffff : Configuration Error for [PhysicalMemoryElementName] on Subsystem [MemoryElementName].**

A Memory DIMM configuration error has been detected.

**Severity**

Error

**Serviceable**

Yes

**Automatically notify support**

No

**Alert Category**

Critical - Memory

**SNMP Trap ID**

41

**CIM Information**

**Prefix:** PLAT ID: 0126

**User Response**

This is a UEFI detected event. The UEFI diagnostic code for this event can be found in the logged IMM message text. Please refer to the UEFI diagnostic code in the "UEFI diagnostic code" section of the Information Center for the appropriate user response.

**Related links**

– “Finding the UEFI diagnostic code” on page 776

- **806f070c-2016ffff : Configuration Error for [PhysicalMemoryElementName] on Subsystem [MemoryElementName].**

A Memory DIMM configuration error has been detected.

**Severity**

Error

**Serviceable**

Yes

**Automatically notify support**

No

**Alert Category**

Critical - Memory

**SNMP Trap ID**

41

**CIM Information**

**Prefix:** PLAT ID: 0126

**User Response**

This is a UEFI detected event. The UEFI diagnostic code for this event can be found in the logged IMM message text. Please refer to the UEFI diagnostic code in the "UEFI diagnostic code" section of the Information Center for the appropriate user response.

**Related links**

– “Finding the UEFI diagnostic code” on page 776

- **806f070c-2017ffff : Configuration Error for [PhysicalMemoryElementName] on Subsystem [MemoryElementName].**

A Memory DIMM configuration error has been detected.

**Severity**

Error

**Serviceable**

Yes

**Automatically notify support**

No

**Alert Category**

Critical - Memory

**SNMP Trap ID**

41

**CIM Information**

**Prefix:** PLAT ID: 0126

**User Response**

This is a UEFI detected event. The UEFI diagnostic code for this event can be found in the logged IMM message text. Please refer to the UEFI diagnostic code in the "UEFI diagnostic code" section of the Information Center for the appropriate user response.

**Related links**

- "Finding the UEFI diagnostic code" on page 776
- **806f070c-2018ffff : Configuration Error for [PhysicalMemoryElementName] on Subsystem [MemoryElementName].**

A Memory DIMM configuration error has been detected.

**Severity**

Error

**Serviceable**

Yes

**Automatically notify support**

No

**Alert Category**

Critical - Memory

**SNMP Trap ID**

41

**CIM Information**

**Prefix:** PLAT ID: 0126

**User Response**

This is a UEFI detected event. The UEFI diagnostic code for this event can be found in the logged IMM message text. Please refer to the UEFI diagnostic code in the "UEFI diagnostic code" section of the Information Center for the appropriate user response.

**Related links**

- "Finding the UEFI diagnostic code" on page 776
- **806f070c-2019ffff : Configuration Error for [PhysicalMemoryElementName] on Subsystem [MemoryElementName].**

A Memory DIMM configuration error has been detected.

**Severity**

Error

**Serviceable**

Yes

**Automatically notify support**

No

**Alert Category**

Critical - Memory

**SNMP Trap ID**

41

**CIM Information**

**Prefix:** PLAT ID: 0126

**User Response**

This is a UEFI detected event. The UEFI diagnostic code for this event can be found in the logged IMM message text. Please refer to the UEFI diagnostic code in the "UEFI diagnostic code" section of the Information Center for the appropriate user response.

**Related links**

– "Finding the UEFI diagnostic code" on page 776

- **806f070c-201affff : Configuration Error for [PhysicalMemoryElementName] on Subsystem [MemoryElementName].**

A Memory DIMM configuration error has been detected.

**Severity**

Error

**Serviceable**

Yes

**Automatically notify support**

No

**Alert Category**

Critical - Memory

**SNMP Trap ID**

41

**CIM Information**

**Prefix:** PLAT ID: 0126

**User Response**

This is a UEFI detected event. The UEFI diagnostic code for this event can be found in the logged IMM message text. Please refer to the UEFI diagnostic code in the "UEFI diagnostic code" section of the Information Center for the appropriate user response.

**Related links**

– "Finding the UEFI diagnostic code" on page 776

- **806f070c-201bffff : Configuration Error for [PhysicalMemoryElementName] on Subsystem [MemoryElementName].**

A Memory DIMM configuration error has been detected.

**Severity**

Error

**Serviceable**

Yes

**Automatically notify support**

No

**Alert Category**

Critical - Memory

**SNMP Trap ID**



**CIM Information****Prefix:** PLAT ID: 0126**User Response**

This is a UEFI detected event. The UEFI diagnostic code for this event can be found in the logged IMM message text. Please refer to the UEFI diagnostic code in the "UEFI diagnostic code" section of the Information Center for the appropriate user response.

**Related links**

- "Finding the UEFI diagnostic code" on page 776
- **806f070c-201cffff : Configuration Error for [PhysicalMemoryElementName] on Subsystem [MemoryElementName].**

A Memory DIMM configuration error has been detected.

**Severity**

Error

**Serviceable**

Yes

**Automatically notify support**

No

**Alert Category**

Critical - Memory

**SNMP Trap ID**

41

**CIM Information****Prefix:** PLAT ID: 0126**User Response**

This is a UEFI detected event. The UEFI diagnostic code for this event can be found in the logged IMM message text. Please refer to the UEFI diagnostic code in the "UEFI diagnostic code" section of the Information Center for the appropriate user response.

**Related links**

- "Finding the UEFI diagnostic code" on page 776
- **806f070c-201dffff : Configuration Error for [PhysicalMemoryElementName] on Subsystem [MemoryElementName].**

A Memory DIMM configuration error has been detected.

**Severity**

Error

**Serviceable**

Yes

**Automatically notify support**

No

**Alert Category**

Critical - Memory

**SNMP Trap ID**

41

**CIM Information****Prefix:** PLAT ID: 0126

**User Response**

This is a UEFI detected event. The UEFI diagnostic code for this event can be found in the logged IMM message text. Please refer to the UEFI diagnostic code in the "UEFI diagnostic code" section of the Information Center for the appropriate user response.

**Related links**

– “Finding the UEFI diagnostic code” on page 776

- **806f070c-201effff : Configuration Error for [PhysicalMemoryElementName] on Subsystem [MemoryElementName].**

A Memory DIMM configuration error has been detected.

**Severity**

Error

**Serviceable**

Yes

**Automatically notify support**

No

**Alert Category**

Critical - Memory

**SNMP Trap ID**

41

**CIM Information**

Prefix: PLAT ID: 0126

**User Response**

This is a UEFI detected event. The UEFI diagnostic code for this event can be found in the logged IMM message text. Please refer to the UEFI diagnostic code in the "UEFI diagnostic code" section of the Information Center for the appropriate user response.

**Related links**

– “Finding the UEFI diagnostic code” on page 776

- **806f070c-201ffff : Configuration Error for [PhysicalMemoryElementName] on Subsystem [MemoryElementName].**

A Memory DIMM configuration error has been detected.

**Severity**

Error

**Serviceable**

Yes

**Automatically notify support**

No

**Alert Category**

Critical - Memory

**SNMP Trap ID**

41

**CIM Information**

Prefix: PLAT ID: 0126

**User Response**

This is a UEFI detected event. The UEFI diagnostic code for this event can be found in the logged IMM message text. Please refer to the UEFI diagnostic code in the "UEFI diagnostic code" section of the Information Center for the appropriate user response.

**Related links**

- "Finding the UEFI diagnostic code" on page 776
- **806f070c-2020ffff : Configuration Error for [PhysicalMemoryElementName] on Subsystem [MemoryElementName].**

A Memory DIMM configuration error has been detected.

**Severity**

Error

**Serviceable**

Yes

**Automatically notify support**

No

**Alert Category**

Critical - Memory

**SNMP Trap ID**

41

**CIM Information**

**Prefix:** PLAT ID: 0126

**User Response**

This is a UEFI detected event. The UEFI diagnostic code for this event can be found in the logged IMM message text. Please refer to the UEFI diagnostic code in the "UEFI diagnostic code" section of the Information Center for the appropriate user response.

**Related links**

- "Finding the UEFI diagnostic code" on page 776
- **806f070c-2021ffff : Configuration Error for [PhysicalMemoryElementName] on Subsystem [MemoryElementName].**

A Memory DIMM configuration error has been detected.

**Severity**

Error

**Serviceable**

Yes

**Automatically notify support**

No

**Alert Category**

Critical - Memory

**SNMP Trap ID**

41

**CIM Information**

**Prefix:** PLAT ID: 0126

**User Response**

This is a UEFI detected event. The UEFI diagnostic code for this event can be found in the logged IMM message text. Please refer to the UEFI diagnostic code in the "UEFI diagnostic code" section of the Information Center for the appropriate user response.

**Related links**

– “Finding the UEFI diagnostic code” on page 776

- **806f070c-2022ffff : Configuration Error for [PhysicalMemoryElementName] on Subsystem [MemoryElementName].**

A Memory DIMM configuration error has been detected.

**Severity**

Error

**Serviceable**

Yes

**Automatically notify support**

No

**Alert Category**

Critical - Memory

**SNMP Trap ID**

41

**CIM Information**

Prefix: PLAT ID: 0126

**User Response**

This is a UEFI detected event. The UEFI diagnostic code for this event can be found in the logged IMM message text. Please refer to the UEFI diagnostic code in the "UEFI diagnostic code" section of the Information Center for the appropriate user response.

**Related links**

– “Finding the UEFI diagnostic code” on page 776

- **806f070c-2023ffff : Configuration Error for [PhysicalMemoryElementName] on Subsystem [MemoryElementName].**

A Memory DIMM configuration error has been detected.

**Severity**

Error

**Serviceable**

Yes

**Automatically notify support**

No

**Alert Category**

Critical - Memory

**SNMP Trap ID**

41

**CIM Information**

Prefix: PLAT ID: 0126

**User Response**

This is a UEFI detected event. The UEFI diagnostic code for this event can be found in the logged IMM message text. Please refer to the UEFI diagnostic code in the "UEFI diagnostic code" section of the Information Center for the appropriate user response.

**Related links**

– “Finding the UEFI diagnostic code” on page 776

- **806f070c-2024ffff : Configuration Error for [PhysicalMemoryElementName] on Subsystem [MemoryElementName].**

A Memory DIMM configuration error has been detected.

**Severity**

Error

**Serviceable**

Yes

**Automatically notify support**

No

**Alert Category**

Critical - Memory

**SNMP Trap ID**

41

**CIM Information**

Prefix: PLAT ID: 0126

**User Response**

This is a UEFI detected event. The UEFI diagnostic code for this event can be found in the logged IMM message text. Please refer to the UEFI diagnostic code in the "UEFI diagnostic code" section of the Information Center for the appropriate user response.

**Related links**

- "Finding the UEFI diagnostic code" on page 776

- **806f070c-2025ffff : Configuration Error for [PhysicalMemoryElementName] on Subsystem [MemoryElementName].**

A Memory DIMM configuration error has been detected.

**Severity**

Error

**Serviceable**

Yes

**Automatically notify support**

No

**Alert Category**

Critical - Memory

**SNMP Trap ID**

41

**CIM Information**

Prefix: PLAT ID: 0126

**User Response**

This is a UEFI detected event. The UEFI diagnostic code for this event can be found in the logged IMM message text. Please refer to the UEFI diagnostic code in the "UEFI diagnostic code" section of the Information Center for the appropriate user response.

**Related links**

- "Finding the UEFI diagnostic code" on page 776

- **806f070c-2026ffff : Configuration Error for [PhysicalMemoryElementName] on Subsystem [MemoryElementName].**

A Memory DIMM configuration error has been detected.

**Severity**

Error

**Serviceable**

Yes

**Automatically notify support**

No

**Alert Category**

Critical - Memory

**SNMP Trap ID**

41

**CIM Information**

**Prefix:** PLAT ID: 0126

**User Response**

This is a UEFI detected event. The UEFI diagnostic code for this event can be found in the logged IMM message text. Please refer to the UEFI diagnostic code in the "UEFI diagnostic code" section of the Information Center for the appropriate user response.

**Related links**

– “Finding the UEFI diagnostic code” on page 776

- **806f070c-2027ffff : Configuration Error for [PhysicalMemoryElementName] on Subsystem [MemoryElementName].**

A Memory DIMM configuration error has been detected.

**Severity**

Error

**Serviceable**

Yes

**Automatically notify support**

No

**Alert Category**

Critical - Memory

**SNMP Trap ID**

41

**CIM Information**

**Prefix:** PLAT ID: 0126

**User Response**

This is a UEFI detected event. The UEFI diagnostic code for this event can be found in the logged IMM message text. Please refer to the UEFI diagnostic code in the "UEFI diagnostic code" section of the Information Center for the appropriate user response.

**Related links**

– “Finding the UEFI diagnostic code” on page 776

- **806f070c-2028ffff : Configuration Error for [PhysicalMemoryElementName] on Subsystem [MemoryElementName].**

A Memory DIMM configuration error has been detected.

**Severity**

Error

**Serviceable**

Yes

**Automatically notify support**

No

**Alert Category**

Critical - Memory

**SNMP Trap ID**

41

**CIM Information**

**Prefix:** PLAT ID: 0126

**User Response**

This is a UEFI detected event. The UEFI diagnostic code for this event can be found in the logged IMM message text. Please refer to the UEFI diagnostic code in the "UEFI diagnostic code" section of the Information Center for the appropriate user response.

**Related links**

- "Finding the UEFI diagnostic code" on page 776
- **806f070c-2029ffff : Configuration Error for [PhysicalMemoryElementName] on Subsystem [MemoryElementName].**

A Memory DIMM configuration error has been detected.

**Severity**

Error

**Serviceable**

Yes

**Automatically notify support**

No

**Alert Category**

Critical - Memory

**SNMP Trap ID**

41

**CIM Information**

**Prefix:** PLAT ID: 0126

**User Response**

This is a UEFI detected event. The UEFI diagnostic code for this event can be found in the logged IMM message text. Please refer to the UEFI diagnostic code in the "UEFI diagnostic code" section of the Information Center for the appropriate user response.

**Related links**

- "Finding the UEFI diagnostic code" on page 776
- **806f070c-202affff : Configuration Error for [PhysicalMemoryElementName] on Subsystem [MemoryElementName].**

A Memory DIMM configuration error has been detected.

**Severity**

Error

**Serviceable**

Yes

**Automatically notify support**

No

**Alert Category**

Critical - Memory

**SNMP Trap ID**

41

**CIM Information**

Prefix: PLAT ID: 0126

**User Response**

This is a UEFI detected event. The UEFI diagnostic code for this event can be found in the logged IMM message text. Please refer to the UEFI diagnostic code in the "UEFI diagnostic code" section of the Information Center for the appropriate user response.

**Related links**

– “Finding the UEFI diagnostic code” on page 776

- **806f070c-202bffff : Configuration Error for [PhysicalMemoryElementName] on Subsystem [MemoryElementName].**

A Memory DIMM configuration error has been detected.

**Severity**

Error

**Serviceable**

Yes

**Automatically notify support**

No

**Alert Category**

Critical - Memory

**SNMP Trap ID**

41

**CIM Information**

Prefix: PLAT ID: 0126

**User Response**

This is a UEFI detected event. The UEFI diagnostic code for this event can be found in the logged IMM message text. Please refer to the UEFI diagnostic code in the "UEFI diagnostic code" section of the Information Center for the appropriate user response.

**Related links**

– “Finding the UEFI diagnostic code” on page 776

- **806f070c-202cffff : Configuration Error for [PhysicalMemoryElementName] on Subsystem [MemoryElementName].**

A Memory DIMM configuration error has been detected.

**Severity**

Error

**Serviceable**

Yes

**Automatically notify support**

No

**Alert Category**

Critical - Memory

**SNMP Trap ID**



**CIM Information****Prefix:** PLAT ID: 0126**User Response**

This is a UEFI detected event. The UEFI diagnostic code for this event can be found in the logged IMM message text. Please refer to the UEFI diagnostic code in the "UEFI diagnostic code" section of the Information Center for the appropriate user response.

**Related links**

- "Finding the UEFI diagnostic code" on page 776
- **806f070c-202dffff : Configuration Error for [PhysicalMemoryElementName] on Subsystem [MemoryElementName].**

A Memory DIMM configuration error has been detected.

**Severity**

Error

**Serviceable**

Yes

**Automatically notify support**

No

**Alert Category**

Critical - Memory

**SNMP Trap ID**

41

**CIM Information****Prefix:** PLAT ID: 0126**User Response**

This is a UEFI detected event. The UEFI diagnostic code for this event can be found in the logged IMM message text. Please refer to the UEFI diagnostic code in the "UEFI diagnostic code" section of the Information Center for the appropriate user response.

**Related links**

- "Finding the UEFI diagnostic code" on page 776
- **806f070c-202effff : Configuration Error for [PhysicalMemoryElementName] on Subsystem [MemoryElementName].**

A Memory DIMM configuration error has been detected.

**Severity**

Error

**Serviceable**

Yes

**Automatically notify support**

No

**Alert Category**

Critical - Memory

**SNMP Trap ID**

41

**CIM Information****Prefix:** PLAT ID: 0126

**User Response**

This is a UEFI detected event. The UEFI diagnostic code for this event can be found in the logged IMM message text. Please refer to the UEFI diagnostic code in the "UEFI diagnostic code" section of the Information Center for the appropriate user response.

**Related links**

– “Finding the UEFI diagnostic code” on page 776

- **806f070c-202ffff : Configuration Error for [PhysicalMemoryElementName] on Subsystem [MemoryElementName].**

A Memory DIMM configuration error has been detected.

**Severity**

Error

**Serviceable**

Yes

**Automatically notify support**

No

**Alert Category**

Critical - Memory

**SNMP Trap ID**

41

**CIM Information**

Prefix: PLAT ID: 0126

**User Response**

This is a UEFI detected event. The UEFI diagnostic code for this event can be found in the logged IMM message text. Please refer to the UEFI diagnostic code in the "UEFI diagnostic code" section of the Information Center for the appropriate user response.

**Related links**

– “Finding the UEFI diagnostic code” on page 776

- **806f070c-2030fff : Configuration Error for [PhysicalMemoryElementName] on Subsystem [MemoryElementName].**

A Memory DIMM configuration error has been detected.

**Severity**

Error

**Serviceable**

Yes

**Automatically notify support**

No

**Alert Category**

Critical - Memory

**SNMP Trap ID**

41

**CIM Information**

Prefix: PLAT ID: 0126

**User Response**

This is a UEFI detected event. The UEFI diagnostic code for this event can be found in the logged IMM message text. Please refer to the UEFI diagnostic code in the "UEFI diagnostic code" section of the Information Center for the appropriate user response.

**Related links**

- "Finding the UEFI diagnostic code" on page 776
- **806f070c-2581ffff : Configuration Error for [PhysicalMemoryElementName] on Subsystem [MemoryElementName].**

A memory DIMM configuration error has been detected.

**Severity**

Error

**Serviceable**

Yes

**Automatically notify support**

No

**Alert Category**

Critical - Memory

**SNMP Trap ID**

41

**CIM Information**

Prefix: PLAT ID: 0126

**User Response**

This is a UEFI detected event. The UEFI diagnostic code for this event can be found in the logged IMM message text. Please refer to the UEFI diagnostic code in the "UEFI diagnostic code" section of the Information Center for the appropriate user response.

**Related links**

- "Finding the UEFI diagnostic code" on page 776
- **806f070d-0400ffff : Rebuild in progress for Array in system [ComputerSystemElementName].**

The array that contains Drive 0 is in the process of being rebuilt.

**Severity**

Info

**Serviceable**

No

**Automatically notify support**

No

**Alert Category**

System - Other

**SNMP Trap ID**

**CIM Information**

Prefix: PLAT ID: 0178

**User Response**

Information only; no action is required.

- **806f070d-0401ffff : Rebuild in progress for Array in system [ComputerSystemElementName].**

The array that contains Drive 1 is in the process of being rebuilt.

**Severity**

Info

**Serviceable**

No

**Automatically notify support**

No

**Alert Category**

System - Other

**SNMP Trap ID****CIM Information****Prefix: PLAT ID:** 0178**User Response**

Information only; no action is required.

- **806f070d-0402ffff : Rebuild in progress for Array in system [ComputerSystemElementName].**

The array that contains Drive 2 is in the process of being rebuilt.

**Severity**

Info

**Serviceable**

No

**Automatically notify support**

No

**Alert Category**

System - Other

**SNMP Trap ID****CIM Information****Prefix: PLAT ID:** 0178**User Response**

Information only; no action is required.

- **806f070d-0403ffff : Rebuild in progress for Array in system [ComputerSystemElementName].**

The array that contains Drive 3 is in the process of being rebuilt.

**Severity**

Info

**Serviceable**

No

**Automatically notify support**

No

**Alert Category**

System - Other

**SNMP Trap ID****CIM Information****Prefix: PLAT ID:** 0178

**User Response**

Information only; no action is required.

- **806f070d-0404ffff : Rebuild in progress for Array in system [ComputerSystemElementName].**

The array that contains Drive 4 is in the process of being rebuilt.

**Severity**

Info

**Serviceable**

No

**Automatically notify support**

No

**Alert Category**

System - Other

**SNMP Trap ID****CIM Information**

Prefix: PLAT ID: 0178

**User Response**

Information only; no action is required.

- **806f070d-0405ffff : Rebuild in progress for Array in system [ComputerSystemElementName].**

The array that contains Drive 5 is in the process of being rebuilt.

**Severity**

Info

**Serviceable**

No

**Automatically notify support**

No

**Alert Category**

System - Other

**SNMP Trap ID****CIM Information**

Prefix: PLAT ID: 0178

**User Response**

Information only; no action is required.

- **806f070d-0406ffff : Rebuild in progress for Array in system [ComputerSystemElementName].**

The array that contains Drive 6 is in the process of being rebuilt.

**Severity**

Info

**Serviceable**

No

**Automatically notify support**

No

**Alert Category**

System - Other

### SNMP Trap ID

#### CIM Information

Prefix: PLAT ID: 0178

#### User Response

Information only; no action is required.

- **806f070d-0407ffff : Rebuild in progress for Array in system [ComputerSystemElementName].**

The array that contains Drive 7 is in the process of being rebuilt.

#### Severity

Info

#### Serviceable

No

#### Automatically notify support

No

#### Alert Category

System - Other

### SNMP Trap ID

#### CIM Information

Prefix: PLAT ID: 0178

#### User Response

Information only; no action is required.

- **806f072b-2101ffff : A successful software or firmware change was detected on system [ComputerSystemElementName].**

A successful software or firmware change (IMM Promotion or IMM Recovery) has been detected.

#### Severity

Info

#### Serviceable

No

#### Automatically notify support

No

#### Alert Category

System - Other

### SNMP Trap ID

#### CIM Information

Prefix: PLAT ID: 0450

#### User Response

Information only; no action is required.

- **806f072b-2201ffff : A successful software or firmware change was detected on system [ComputerSystemElementName].**

Successful Software or Firmware Change occurred for Bkup Auto Update or ROM Recovery.

**Severity**

Info

**Serviceable**

No

**Automatically notify support**

No

**Alert Category**

System - Other

**SNMP Trap ID****CIM Information**

Prefix: PLAT ID: 0450

**User Response**

Information only; no action is required.

- **806f0807-0301ffff : CPU 1 has been Disabled.**

A Processor has been Disabled.

**Severity**

Info

**Serviceable**

No

**Automatically notify support**

No

**Alert Category**

System - Other

**SNMP Trap ID****CIM Information**

Prefix: PLAT ID: 0061

**User Response**

This is a UEFI detected event. The UEFI diagnostic code for this event can be found in the logged IMM message text. Please refer to the UEFI diagnostic code in the "UEFI diagnostic code" section of the Information Center for the appropriate user response.

**Related links**

– "Finding the UEFI diagnostic code" on page 776

- **806f0807-0302ffff : CPU 2 has been Disabled.**

A Processor has been Disabled.

**Severity**

Info

**Serviceable**

No

**Automatically notify support**

No

**Alert Category**

System - Other

## SNMP Trap ID

### CIM Information

Prefix: PLAT ID: 0061

### User Response

This is a UEFI detected event. The UEFI diagnostic code for this event can be found in the logged IMM message text. Please refer to the UEFI diagnostic code in the "UEFI diagnostic code" section of the Information Center for the appropriate user response.

### Related links

– “Finding the UEFI diagnostic code” on page 776

- **806f0807-0303ffff : CPU 3 has been Disabled.**

A Processor has been Disabled.

### Severity

Info

### Serviceable

No

### Automatically notify support

No

### Alert Category

System - Other

## SNMP Trap ID

### CIM Information

Prefix: PLAT ID: 0061

### User Response

This is a UEFI detected event. The UEFI diagnostic code for this event can be found in the logged IMM message text. Please refer to the UEFI diagnostic code in the "UEFI diagnostic code" section of the Information Center for the appropriate user response.

### Related links

– “Finding the UEFI diagnostic code” on page 776

- **806f0807-0304ffff : CPU 4 has been Disabled.**

A Processor has been Disabled.

### Severity

Info

### Serviceable

No

### Automatically notify support

No

### Alert Category

System - Other

## SNMP Trap ID

### CIM Information

Prefix: PLAT ID: 0061



**User Response**

This is a UEFI detected event. The UEFI diagnostic code for this event can be found in the logged IMM message text. Please refer to the UEFI diagnostic code in the "UEFI diagnostic code" section of the Information Center for the appropriate user response.

**Related links**

- "Finding the UEFI diagnostic code" on page 776
- **806f0807-2584ffff : [ProcessorElementName] has been Disabled.**

A processor has been Disabled. All CPUs. One of CPUs.

**Severity**

Info

**Serviceable**

No

**Automatically notify support**

No

**Alert Category**

System - Other

**SNMP Trap ID****CIM Information**

Prefix: PLAT ID: 0061

**User Response**

This is a UEFI detected event. The UEFI diagnostic code for this event can be found in the logged IMM message text. Please refer to the UEFI diagnostic code in the "UEFI diagnostic code" section of the Information Center for the appropriate user response.

**Related links**

- "Finding the UEFI diagnostic code" on page 776
- **806f0813-2581ffff : A Uncorrectable Bus Error has occurred on system [ComputerSystemElementName].**

A catastrophic system error has occurred. The system firmware will attempt to analyze the failure to determine whether the failure was due to a hardware component or a software component.

**Severity**

Error

**Serviceable**

Yes

**Automatically notify support**

Yes

**Alert Category**

Critical - Other

**SNMP Trap ID**

50

**CIM Information**

Prefix: PLAT ID: 0240

**User Response**

1. Check <http://www.ibm.com/supportportal/> for RETAIN tips or firmware updates that might correct the error.

2. Make sure that all I/O expansion adapters have correct and matching levels of device drivers and firmware.
3. Check the system-event log for additional information about failing components.
4. If there are no entries related to the error in the system-event log, contact IBM Support and send DSA data to IBM.

- **806f0813-2584ffff : A Uncorrectable Bus Error has occurred on system [ComputerSystemElementName].**

A catastrophic system error has occurred. The system firmware will attempt to analyze the failure to determine whether the failure was due to a hardware component or a software component.

**Severity**

Error

**Serviceable**

Yes

**Automatically notify support**

Yes

**Alert Category**

Critical - Other

**SNMP Trap ID**

50

**CIM Information**

**Prefix:** PLAT ID: 0240

**User Response**

1. Check <http://www.ibm.com/supportportal/> for RETAIN tips or firmware updates that might correct the error.
2. Make sure that all I/O expansion adapters have correct and matching levels of device drivers and firmware.
3. Check the system-event log for additional information about failing components.
4. If there are no entries related to the error in the system-event log, contact IBM Support and send DSA data to IBM.

- **806f0823-2101ffff : Watchdog Timer interrupt occurred for [WatchdogElementName].**

The IPMI watchdog timer has expired. A watchdog interrupt has occurred.

**Severity**

Info

**Serviceable**

No

**Automatically notify support**

No

**Alert Category**

System - Other

**SNMP Trap ID**

**CIM Information**

**Prefix:** PLAT ID: 0376

**User Response**

Information only; no action is required.

- **806f090c-2001ffff : [PhysicalMemoryElementName] on Subsystem [MemoryElementName] Throttled.**

Memory has been Throttled.

**Severity**

Warning

**Serviceable**

Yes

**Automatically notify support**

No

**Alert Category**

System - Other

**SNMP Trap ID**

22

**CIM Information**

**Prefix:** PLAT ID: 0142

**User Response**

Complete the following steps:

1. Check the CMM or FSM event log for any fan or cooling related issues.
2. Make sure that the airflow at the front and rear of the chassis is not obstructed and that fillers are in place and correctly installed.
3. Make sure that the room temperature is within operating specifications.
4. Make sure that the DIMM baffles are in place.
5. If the problem persists and there are no other DIMMs with the same indication, replace the DIMM.

- **806f090c-2002ffff : [PhysicalMemoryElementName] on Subsystem [MemoryElementName] Throttled.**

Memory has been Throttled.

**Severity**

Warning

**Serviceable**

Yes

**Automatically notify support**

No

**Alert Category**

System - Other

**SNMP Trap ID**

22

**CIM Information**

**Prefix:** PLAT ID: 0142

**User Response**

Complete the following steps:

1. Check the CMM or FSM event log for any fan or cooling related issues.
  2. Make sure that the airflow at the front and rear of the chassis is not obstructed and that fillers are in place and correctly installed.
  3. Make sure that the room temperature is within operating specifications.
  4. Make sure that the DIMM baffles are in place.
  5. If the problem persists and there are no other DIMMs with the same indication, replace the DIMM.
- **806f090c-2003ffff : [PhysicalMemoryElementName] on Subsystem [MemoryElementName] Throttled.**

Memory has been Throttled.

**Severity**

Warning

**Serviceable**

Yes

**Automatically notify support**

No

**Alert Category**

System - Other

**SNMP Trap ID**

22

**CIM Information**

**Prefix: PLAT ID:** 0142

**User Response**

Complete the following steps:

1. Check the CMM or FSM event log for any fan or cooling related issues.
  2. Make sure that the airflow at the front and rear of the chassis is not obstructed and that fillers are in place and correctly installed.
  3. Make sure that the room temperature is within operating specifications.
  4. Make sure that the DIMM baffles are in place.
  5. If the problem persists and there are no other DIMMs with the same indication, replace the DIMM.
- **806f090c-2004ffff : [PhysicalMemoryElementName] on Subsystem [MemoryElementName] Throttled.**

Memory has been Throttled.

**Severity**

Warning

**Serviceable**

Yes

**Automatically notify support**

No

**Alert Category**

System - Other

**SNMP Trap ID**

**CIM Information****Prefix:** PLAT ID: 0142**User Response**

Complete the following steps:

1. Check the CMM or FSM event log for any fan or cooling related issues.
  2. Make sure that the airflow at the front and rear of the chassis is not obstructed and that fillers are in place and correctly installed.
  3. Make sure that the room temperature is within operating specifications.
  4. Make sure that the DIMM baffles are in place.
  5. If the problem persists and there are no other DIMMs with the same indication, replace the DIMM.
- **806f090c-2005ffff : [PhysicalMemoryElementName] on Subsystem [MemoryElementName] Throttled.**

Memory has been Throttled.

**Severity**

Warning

**Serviceable**

Yes

**Automatically notify support**

No

**Alert Category**

System - Other

**SNMP Trap ID**

22

**CIM Information****Prefix:** PLAT ID: 0142**User Response**

Complete the following steps:

1. Check the CMM or FSM event log for any fan or cooling related issues.
  2. Make sure that the airflow at the front and rear of the chassis is not obstructed and that fillers are in place and correctly installed.
  3. Make sure that the room temperature is within operating specifications.
  4. Make sure that the DIMM baffles are in place.
  5. If the problem persists and there are no other DIMMs with the same indication, replace the DIMM.
- **806f090c-2006ffff : [PhysicalMemoryElementName] on Subsystem [MemoryElementName] Throttled.**

Memory has been Throttled.

**Severity**

Warning

**Serviceable**

Yes

**Automatically notify support**

No

**Alert Category**

System - Other

**SNMP Trap ID**

22

**CIM Information**

**Prefix: PLAT ID:** 0142

**User Response**

Complete the following steps:

1. Check the CMM or FSM event log for any fan or cooling related issues.
2. Make sure that the airflow at the front and rear of the chassis is not obstructed and that fillers are in place and correctly installed.
3. Make sure that the room temperature is within operating specifications.
4. Make sure that the DIMM baffles are in place.
5. If the problem persists and there are no other DIMMs with the same indication, replace the DIMM.

- **806f090c-2007ffff : [PhysicalMemoryElementName] on Subsystem [MemoryElementName] Throttled.**

Memory has been Throttled.

**Severity**

Warning

**Serviceable**

Yes

**Automatically notify support**

No

**Alert Category**

System - Other

**SNMP Trap ID**

22

**CIM Information**

**Prefix: PLAT ID:** 0142

**User Response**

Complete the following steps:

1. Check the CMM or FSM event log for any fan or cooling related issues.
2. Make sure that the airflow at the front and rear of the chassis is not obstructed and that fillers are in place and correctly installed.
3. Make sure that the room temperature is within operating specifications.
4. Make sure that the DIMM baffles are in place.
5. If the problem persists and there are no other DIMMs with the same indication, replace the DIMM.

- **806f090c-2008ffff : [PhysicalMemoryElementName] on Subsystem [MemoryElementName] Throttled.**

Memory has been Throttled.

**Severity**

Warning

**Serviceable**

Yes

**Automatically notify support**

No

**Alert Category**

System - Other

**SNMP Trap ID**

22

**CIM Information**

**Prefix:** PLAT ID: 0142

**User Response**

Complete the following steps:

1. Check the CMM or FSM event log for any fan or cooling related issues.
2. Make sure that the airflow at the front and rear of the chassis is not obstructed and that fillers are in place and correctly installed.
3. Make sure that the room temperature is within operating specifications.
4. Make sure that the DIMM baffles are in place.
5. If the problem persists and there are no other DIMMs with the same indication, replace the DIMM.

- **806f090c-2009ffff : [PhysicalMemoryElementName] on Subsystem [MemoryElementName] Throttled.**

Memory has been Throttled.

**Severity**

Warning

**Serviceable**

Yes

**Automatically notify support**

No

**Alert Category**

System - Other

**SNMP Trap ID**

22

**CIM Information**

**Prefix:** PLAT ID: 0142

**User Response**

Complete the following steps:

1. Check the CMM or FSM event log for any fan or cooling related issues.

2. Make sure that the airflow at the front and rear of the chassis is not obstructed and that fillers are in place and correctly installed.
3. Make sure that the room temperature is within operating specifications.
4. Make sure that the DIMM baffles are in place.
5. If the problem persists and there are no other DIMMs with the same indication, replace the DIMM.

- **806f090c-200affff : [PhysicalMemoryElementName] on Subsystem [MemoryElementName] Throttled.**

Memory has been Throttled.

**Severity**

Warning

**Serviceable**

Yes

**Automatically notify support**

No

**Alert Category**

System - Other

**SNMP Trap ID**

22

**CIM Information**

**Prefix:** PLAT **ID:** 0142

**User Response**

Complete the following steps:

1. Check the CMM or FSM event log for any fan or cooling related issues.
2. Make sure that the airflow at the front and rear of the chassis is not obstructed and that fillers are in place and correctly installed.
3. Make sure that the room temperature is within operating specifications.
4. Make sure that the DIMM baffles are in place.
5. If the problem persists and there are no other DIMMs with the same indication, replace the DIMM.

- **806f090c-200bffff : [PhysicalMemoryElementName] on Subsystem [MemoryElementName] Throttled.**

Memory has been Throttled.

**Severity**

Warning

**Serviceable**

Yes

**Automatically notify support**

No

**Alert Category**

System - Other

**SNMP Trap ID**

22



**CIM Information**

Prefix: PLAT ID: 0142

**User Response**

Complete the following steps:

1. Check the CMM or FSM event log for any fan or cooling related issues.
2. Make sure that the airflow at the front and rear of the chassis is not obstructed and that fillers are in place and correctly installed.
3. Make sure that the room temperature is within operating specifications.
4. Make sure that the DIMM baffles are in place.
5. If the problem persists and there are no other DIMMs with the same indication, replace the DIMM.

- **806f090c-200cffff : [PhysicalMemoryElementName] on Subsystem [MemoryElementName] Throttled.**

Memory has been Throttled.

**Severity**

Warning

**Serviceable**

Yes

**Automatically notify support**

No

**Alert Category**

System - Other

**SNMP Trap ID**

22

**CIM Information**

Prefix: PLAT ID: 0142

**User Response**

Complete the following steps:

1. Check the CMM or FSM event log for any fan or cooling related issues.
2. Make sure that the airflow at the front and rear of the chassis is not obstructed and that fillers are in place and correctly installed.
3. Make sure that the room temperature is within operating specifications.
4. Make sure that the DIMM baffles are in place.
5. If the problem persists and there are no other DIMMs with the same indication, replace the DIMM.

- **806f090c-200dffff : [PhysicalMemoryElementName] on Subsystem [MemoryElementName] Throttled.**

Memory has been Throttled.

**Severity**

Warning

**Serviceable**

Yes

**Automatically notify support**

No

**Alert Category**

System - Other

**SNMP Trap ID**

22

**CIM Information**

**Prefix:** PLAT ID: 0142

**User Response**

Complete the following steps:

1. Check the CMM or FSM event log for any fan or cooling related issues.
2. Make sure that the airflow at the front and rear of the chassis is not obstructed and that fillers are in place and correctly installed.
3. Make sure that the room temperature is within operating specifications.
4. Make sure that the DIMM baffles are in place.
5. If the problem persists and there are no other DIMMs with the same indication, replace the DIMM.

- **806f090c-200effff : [PhysicalMemoryElementName] on Subsystem [MemoryElementName] Throttled.**

Memory has been Throttled.

**Severity**

Warning

**Serviceable**

Yes

**Automatically notify support**

No

**Alert Category**

System - Other

**SNMP Trap ID**

22

**CIM Information**

**Prefix:** PLAT ID: 0142

**User Response**

Complete the following steps:

1. Check the CMM or FSM event log for any fan or cooling related issues.
2. Make sure that the airflow at the front and rear of the chassis is not obstructed and that fillers are in place and correctly installed.
3. Make sure that the room temperature is within operating specifications.
4. Make sure that the DIMM baffles are in place.
5. If the problem persists and there are no other DIMMs with the same indication, replace the DIMM.

- **806f090c-200fffff : [PhysicalMemoryElementName] on Subsystem [MemoryElementName] Throttled.**

Memory has been Throttled.

**Severity**

Warning

**Serviceable**

Yes

**Automatically notify support**

No

**Alert Category**

System - Other

**SNMP Trap ID**

22

**CIM Information**

**Prefix: PLAT ID:** 0142

**User Response**

Complete the following steps:

1. Check the CMM or FSM event log for any fan or cooling related issues.
2. Make sure that the airflow at the front and rear of the chassis is not obstructed and that fillers are in place and correctly installed.
3. Make sure that the room temperature is within operating specifications.
4. Make sure that the DIMM baffles are in place.
5. If the problem persists and there are no other DIMMs with the same indication, replace the DIMM.

- **806f090c-2010ffff : [PhysicalMemoryElementName] on Subsystem [MemoryElementName] Throttled.**

Memory has been Throttled.

**Severity**

Warning

**Serviceable**

Yes

**Automatically notify support**

No

**Alert Category**

System - Other

**SNMP Trap ID**

22

**CIM Information**

**Prefix: PLAT ID:** 0142

**User Response**

Complete the following steps:

1. Check the CMM or FSM event log for any fan or cooling related issues.
2. Make sure that the airflow at the front and rear of the chassis is not obstructed and that fillers are in place and correctly installed.

3. Make sure that the room temperature is within operating specifications.
  4. Make sure that the DIMM baffles are in place.
  5. If the problem persists and there are no other DIMMs with the same indication, replace the DIMM.
- **806f090c-2011ffff : [PhysicalMemoryElementName] on Subsystem [MemoryElementName] Throttled.**

Memory has been Throttled.

**Severity**

Warning

**Serviceable**

Yes

**Automatically notify support**

No

**Alert Category**

System - Other

**SNMP Trap ID**

22

**CIM Information**

**Prefix: PLAT ID:** 0142

**User Response**

Complete the following steps:

1. Check the CMM or FSM event log for any fan or cooling related issues.
  2. Make sure that the airflow at the front and rear of the chassis is not obstructed and that fillers are in place and correctly installed.
  3. Make sure that the room temperature is within operating specifications.
  4. Make sure that the DIMM baffles are in place.
  5. If the problem persists and there are no other DIMMs with the same indication, replace the DIMM.
- **806f090c-2012ffff : [PhysicalMemoryElementName] on Subsystem [MemoryElementName] Throttled.**

Memory has been Throttled.

**Severity**

Warning

**Serviceable**

Yes

**Automatically notify support**

No

**Alert Category**

System - Other

**SNMP Trap ID**

22

**CIM Information**

**Prefix: PLAT ID:** 0142

## User Response

Complete the following steps:

1. Check the CMM or FSM event log for any fan or cooling related issues.
2. Make sure that the airflow at the front and rear of the chassis is not obstructed and that fillers are in place and correctly installed.
3. Make sure that the room temperature is within operating specifications.
4. Make sure that the DIMM baffles are in place.
5. If the problem persists and there are no other DIMMs with the same indication, replace the DIMM.

- **806f090c-2013ffff : [PhysicalMemoryElementName] on Subsystem [MemoryElementName] Throttled.**

Memory has been Throttled.

### Severity

Warning

### Serviceable

Yes

### Automatically notify support

No

### Alert Category

System - Other

### SNMP Trap ID

22

### CIM Information

**Prefix:** PLAT ID: 0142

## User Response

Complete the following steps:

1. Check the CMM or FSM event log for any fan or cooling related issues.
2. Make sure that the airflow at the front and rear of the chassis is not obstructed and that fillers are in place and correctly installed.
3. Make sure that the room temperature is within operating specifications.
4. Make sure that the DIMM baffles are in place.
5. If the problem persists and there are no other DIMMs with the same indication, replace the DIMM.

- **806f090c-2014ffff : [PhysicalMemoryElementName] on Subsystem [MemoryElementName] Throttled.**

Memory has been Throttled.

### Severity

Warning

### Serviceable

Yes

### Automatically notify support

No

**Alert Category**

System - Other

**SNMP Trap ID**

22

**CIM Information**

**Prefix:** PLAT ID: 0142

**User Response**

Complete the following steps:

1. Check the CMM or FSM event log for any fan or cooling related issues.
  2. Make sure that the airflow at the front and rear of the chassis is not obstructed and that fillers are in place and correctly installed.
  3. Make sure that the room temperature is within operating specifications.
  4. Make sure that the DIMM baffles are in place.
  5. If the problem persists and there are no other DIMMs with the same indication, replace the DIMM.
- **806f090c-2015ffff : [PhysicalMemoryElementName] on Subsystem [MemoryElementName] Throttled.**

Memory has been Throttled.

**Severity**

Warning

**Serviceable**

Yes

**Automatically notify support**

No

**Alert Category**

System - Other

**SNMP Trap ID**

22

**CIM Information**

**Prefix:** PLAT ID: 0142

**User Response**

Complete the following steps:

1. Check the CMM or FSM event log for any fan or cooling related issues.
  2. Make sure that the airflow at the front and rear of the chassis is not obstructed and that fillers are in place and correctly installed.
  3. Make sure that the room temperature is within operating specifications.
  4. Make sure that the DIMM baffles are in place.
  5. If the problem persists and there are no other DIMMs with the same indication, replace the DIMM.
- **806f090c-2016ffff : [PhysicalMemoryElementName] on Subsystem [MemoryElementName] Throttled.**

Memory has been Throttled.

**Severity**

Warning

**Serviceable**

Yes

**Automatically notify support**

No

**Alert Category**

System - Other

**SNMP Trap ID**

22

**CIM Information****Prefix: PLAT ID:** 0142**User Response**

Complete the following steps:

1. Check the CMM or FSM event log for any fan or cooling related issues.
  2. Make sure that the airflow at the front and rear of the chassis is not obstructed and that fillers are in place and correctly installed.
  3. Make sure that the room temperature is within operating specifications.
  4. Make sure that the DIMM baffles are in place.
  5. If the problem persists and there are no other DIMMs with the same indication, replace the DIMM.
- **806f090c-2017ffff : [PhysicalMemoryElementName] on Subsystem [MemoryElementName] Throttled.**

Memory has been Throttled.

**Severity**

Warning

**Serviceable**

Yes

**Automatically notify support**

No

**Alert Category**

System - Other

**SNMP Trap ID**

22

**CIM Information****Prefix: PLAT ID:** 0142**User Response**

Complete the following steps:

1. Check the CMM or FSM event log for any fan or cooling related issues.
2. Make sure that the airflow at the front and rear of the chassis is not obstructed and that fillers are in place and correctly installed.
3. Make sure that the room temperature is within operating specifications.

4. Make sure that the DIMM baffles are in place.
5. If the problem persists and there are no other DIMMs with the same indication, replace the DIMM.

- **806f090c-2018ffff : [PhysicalMemoryElementName] on Subsystem [MemoryElementName] Throttled.**

Memory has been Throttled.

**Severity**

Warning

**Serviceable**

Yes

**Automatically notify support**

No

**Alert Category**

System - Other

**SNMP Trap ID**

22

**CIM Information**

**Prefix: PLAT ID:** 0142

**User Response**

Complete the following steps:

1. Check the CMM or FSM event log for any fan or cooling related issues.
2. Make sure that the airflow at the front and rear of the chassis is not obstructed and that fillers are in place and correctly installed.
3. Make sure that the room temperature is within operating specifications.
4. Make sure that the DIMM baffles are in place.
5. If the problem persists and there are no other DIMMs with the same indication, replace the DIMM.

- **806f090c-2019ffff : [PhysicalMemoryElementName] on Subsystem [MemoryElementName] Throttled.**

Memory has been Throttled.

**Severity**

Warning

**Serviceable**

Yes

**Automatically notify support**

No

**Alert Category**

System - Other

**SNMP Trap ID**

22

**CIM Information**

**Prefix: PLAT ID:** 0142

**User Response**



Complete the following steps:

1. Check the CMM or FSM event log for any fan or cooling related issues.
2. Make sure that the airflow at the front and rear of the chassis is not obstructed and that fillers are in place and correctly installed.
3. Make sure that the room temperature is within operating specifications.
4. Make sure that the DIMM baffles are in place.
5. If the problem persists and there are no other DIMMs with the same indication, replace the DIMM.

- **806f090c-201afff : [PhysicalMemoryElementName] on Subsystem [MemoryElementName] Throttled.**

Memory has been Throttled.

**Severity**

Warning

**Serviceable**

Yes

**Automatically notify support**

No

**Alert Category**

System - Other

**SNMP Trap ID**

22

**CIM Information**

**Prefix:** PLAT ID: 0142

**User Response**

Complete the following steps:

1. Check the CMM or FSM event log for any fan or cooling related issues.
2. Make sure that the airflow at the front and rear of the chassis is not obstructed and that fillers are in place and correctly installed.
3. Make sure that the room temperature is within operating specifications.
4. Make sure that the DIMM baffles are in place.
5. If the problem persists and there are no other DIMMs with the same indication, replace the DIMM.

- **806f090c-201bfff : [PhysicalMemoryElementName] on Subsystem [MemoryElementName] Throttled.**

Memory has been Throttled.

**Severity**

Warning

**Serviceable**

Yes

**Automatically notify support**

No

**Alert Category**

System - Other

**SNMP Trap ID**

22

**CIM Information****Prefix:** PLAT ID: 0142**User Response**

Complete the following steps:

1. Check the CMM or FSM event log for any fan or cooling related issues.
2. Make sure that the airflow at the front and rear of the chassis is not obstructed and that fillers are in place and correctly installed.
3. Make sure that the room temperature is within operating specifications.
4. Make sure that the DIMM baffles are in place.
5. If the problem persists and there are no other DIMMs with the same indication, replace the DIMM.

- **806f090c-201cffff : [PhysicalMemoryElementName] on Subsystem [MemoryElementName] Throttled.**

Memory has been Throttled.

**Severity**

Warning

**Serviceable**

Yes

**Automatically notify support**

No

**Alert Category**

System - Other

**SNMP Trap ID**

22

**CIM Information****Prefix:** PLAT ID: 0142**User Response**

Complete the following steps:

1. Check the CMM or FSM event log for any fan or cooling related issues.
2. Make sure that the airflow at the front and rear of the chassis is not obstructed and that fillers are in place and correctly installed.
3. Make sure that the room temperature is within operating specifications.
4. Make sure that the DIMM baffles are in place.
5. If the problem persists and there are no other DIMMs with the same indication, replace the DIMM.

- **806f090c-201dffff : [PhysicalMemoryElementName] on Subsystem [MemoryElementName] Throttled.**

Memory has been Throttled.

**Severity**

Warning

**Serviceable**

Yes

**Automatically notify support**

No

**Alert Category**

System - Other

**SNMP Trap ID**

22

**CIM Information**

**Prefix:** PLAT ID: 0142

**User Response**

Complete the following steps:

1. Check the CMM or FSM event log for any fan or cooling related issues.
  2. Make sure that the airflow at the front and rear of the chassis is not obstructed and that fillers are in place and correctly installed.
  3. Make sure that the room temperature is within operating specifications.
  4. Make sure that the DIMM baffles are in place.
  5. If the problem persists and there are no other DIMMs with the same indication, replace the DIMM.
- **806f090c-201effff : [PhysicalMemoryElementName] on Subsystem [MemoryElementName] Throttled.**

Memory has been Throttled.

**Severity**

Warning

**Serviceable**

Yes

**Automatically notify support**

No

**Alert Category**

System - Other

**SNMP Trap ID**

22

**CIM Information**

**Prefix:** PLAT ID: 0142

**User Response**

Complete the following steps:

1. Check the CMM or FSM event log for any fan or cooling related issues.
2. Make sure that the airflow at the front and rear of the chassis is not obstructed and that fillers are in place and correctly installed.
3. Make sure that the room temperature is within operating specifications.
4. Make sure that the DIMM baffles are in place.
5. If the problem persists and there are no other DIMMs with the same indication, replace the DIMM.

- **806f090c-201ffff : [PhysicalMemoryElementName] on Subsystem [MemoryElementName] Throttled.**

Memory has been Throttled.

**Severity**

Warning

**Serviceable**

Yes

**Automatically notify support**

No

**Alert Category**

System - Other

**SNMP Trap ID**

22

**CIM Information**

Prefix: PLAT ID: 0142

**User Response**

Complete the following steps:

1. Check the CMM or FSM event log for any fan or cooling related issues.
2. Make sure that the airflow at the front and rear of the chassis is not obstructed and that fillers are in place and correctly installed.
3. Make sure that the room temperature is within operating specifications.
4. Make sure that the DIMM baffles are in place.
5. If the problem persists and there are no other DIMMs with the same indication, replace the DIMM.

- **806f090c-2020ffff : [PhysicalMemoryElementName] on Subsystem [MemoryElementName] Throttled.**

Memory has been Throttled.

**Severity**

Warning

**Serviceable**

Yes

**Automatically notify support**

No

**Alert Category**

System - Other

**SNMP Trap ID**

22

**CIM Information**

Prefix: PLAT ID: 0142

**User Response**

Complete the following steps:

1. Check the CMM or FSM event log for any fan or cooling related issues.

2. Make sure that the airflow at the front and rear of the chassis is not obstructed and that fillers are in place and correctly installed.
3. Make sure that the room temperature is within operating specifications.
4. Make sure that the DIMM baffles are in place.
5. If the problem persists and there are no other DIMMs with the same indication, replace the DIMM.

- **806f090c-2021ffff : [PhysicalMemoryElementName] on Subsystem [MemoryElementName] Throttled.**

Memory has been Throttled.

**Severity**

Warning

**Serviceable**

Yes

**Automatically notify support**

No

**Alert Category**

System - Other

**SNMP Trap ID**

22

**CIM Information**

**Prefix:** PLAT **ID:** 0142

**User Response**

Complete the following steps:

1. Check the CMM or FSM event log for any fan or cooling related issues.
2. Make sure that the airflow at the front and rear of the chassis is not obstructed and that fillers are in place and correctly installed.
3. Make sure that the room temperature is within operating specifications.
4. Make sure that the DIMM baffles are in place.
5. If the problem persists and there are no other DIMMs with the same indication, replace the DIMM.

- **806f090c-2022ffff : [PhysicalMemoryElementName] on Subsystem [MemoryElementName] Throttled.**

Memory has been Throttled.

**Severity**

Warning

**Serviceable**

Yes

**Automatically notify support**

No

**Alert Category**

System - Other

**SNMP Trap ID**

22

**CIM Information**

Prefix: PLAT ID: 0142

**User Response**

Complete the following steps:

1. Check the CMM or FSM event log for any fan or cooling related issues.
2. Make sure that the airflow at the front and rear of the chassis is not obstructed and that fillers are in place and correctly installed.
3. Make sure that the room temperature is within operating specifications.
4. Make sure that the DIMM baffles are in place.
5. If the problem persists and there are no other DIMMs with the same indication, replace the DIMM.

- **806f090c-2023ffff : [PhysicalMemoryElementName] on Subsystem [MemoryElementName] Throttled.**

Memory has been Throttled.

**Severity**

Warning

**Serviceable**

Yes

**Automatically notify support**

No

**Alert Category**

System - Other

**SNMP Trap ID**

22

**CIM Information**

Prefix: PLAT ID: 0142

**User Response**

Complete the following steps:

1. Check the CMM or FSM event log for any fan or cooling related issues.
2. Make sure that the airflow at the front and rear of the chassis is not obstructed and that fillers are in place and correctly installed.
3. Make sure that the room temperature is within operating specifications.
4. Make sure that the DIMM baffles are in place.
5. If the problem persists and there are no other DIMMs with the same indication, replace the DIMM.

- **806f090c-2024ffff : [PhysicalMemoryElementName] on Subsystem [MemoryElementName] Throttled.**

Memory has been Throttled.

**Severity**

Warning

**Serviceable**

Yes

**Automatically notify support**

No

**Alert Category**

System - Other

**SNMP Trap ID**

22

**CIM Information**

**Prefix:** PLAT ID: 0142

**User Response**

Complete the following steps:

1. Check the CMM or FSM event log for any fan or cooling related issues.
2. Make sure that the airflow at the front and rear of the chassis is not obstructed and that fillers are in place and correctly installed.
3. Make sure that the room temperature is within operating specifications.
4. Make sure that the DIMM baffles are in place.
5. If the problem persists and there are no other DIMMs with the same indication, replace the DIMM.

- **806f090c-2025ffff : [PhysicalMemoryElementName] on Subsystem [MemoryElementName] Throttled.**

Memory has been Throttled.

**Severity**

Warning

**Serviceable**

Yes

**Automatically notify support**

No

**Alert Category**

System - Other

**SNMP Trap ID**

22

**CIM Information**

**Prefix:** PLAT ID: 0142

**User Response**

Complete the following steps:

1. Check the CMM or FSM event log for any fan or cooling related issues.
2. Make sure that the airflow at the front and rear of the chassis is not obstructed and that fillers are in place and correctly installed.
3. Make sure that the room temperature is within operating specifications.
4. Make sure that the DIMM baffles are in place.
5. If the problem persists and there are no other DIMMs with the same indication, replace the DIMM.

- **806f090c-2026ffff : [PhysicalMemoryElementName] on Subsystem [MemoryElementName] Throttled.**

Memory has been Throttled.

**Severity**

Warning

**Serviceable**

Yes

**Automatically notify support**

No

**Alert Category**

System - Other

**SNMP Trap ID**

22

**CIM Information**

**Prefix: PLAT ID:** 0142

**User Response**

Complete the following steps:

1. Check the CMM or FSM event log for any fan or cooling related issues.
2. Make sure that the airflow at the front and rear of the chassis is not obstructed and that fillers are in place and correctly installed.
3. Make sure that the room temperature is within operating specifications.
4. Make sure that the DIMM baffles are in place.
5. If the problem persists and there are no other DIMMs with the same indication, replace the DIMM.

- **806f090c-2027ffff : [PhysicalMemoryElementName] on Subsystem [MemoryElementName] Throttled.**

Memory has been Throttled.

**Severity**

Warning

**Serviceable**

Yes

**Automatically notify support**

No

**Alert Category**

System - Other

**SNMP Trap ID**

22

**CIM Information**

**Prefix: PLAT ID:** 0142

**User Response**

Complete the following steps:

1. Check the CMM or FSM event log for any fan or cooling related issues.
2. Make sure that the airflow at the front and rear of the chassis is not obstructed and that fillers are in place and correctly installed.



3. Make sure that the room temperature is within operating specifications.
4. Make sure that the DIMM baffles are in place.
5. If the problem persists and there are no other DIMMs with the same indication, replace the DIMM.

- **806f090c-2028ffff : [PhysicalMemoryElementName] on Subsystem [MemoryElementName] Throttled.**

Memory has been Throttled.

**Severity**

Warning

**Serviceable**

Yes

**Automatically notify support**

No

**Alert Category**

System - Other

**SNMP Trap ID**

22

**CIM Information**

**Prefix:** PLAT ID: 0142

**User Response**

Complete the following steps:

1. Check the CMM or FSM event log for any fan or cooling related issues.
2. Make sure that the airflow at the front and rear of the chassis is not obstructed and that fillers are in place and correctly installed.
3. Make sure that the room temperature is within operating specifications.
4. Make sure that the DIMM baffles are in place.
5. If the problem persists and there are no other DIMMs with the same indication, replace the DIMM.

- **806f090c-2029ffff : [PhysicalMemoryElementName] on Subsystem [MemoryElementName] Throttled.**

Memory has been Throttled.

**Severity**

Warning

**Serviceable**

Yes

**Automatically notify support**

No

**Alert Category**

System - Other

**SNMP Trap ID**

22

**CIM Information**

**Prefix:** PLAT ID: 0142

## User Response

Complete the following steps:

1. Check the CMM or FSM event log for any fan or cooling related issues.
2. Make sure that the airflow at the front and rear of the chassis is not obstructed and that fillers are in place and correctly installed.
3. Make sure that the room temperature is within operating specifications.
4. Make sure that the DIMM baffles are in place.
5. If the problem persists and there are no other DIMMs with the same indication, replace the DIMM.

- **806f090c-202affff : [PhysicalMemoryElementName] on Subsystem [MemoryElementName] Throttled.**

Memory has been Throttled.

### Severity

Warning

### Serviceable

Yes

### Automatically notify support

No

### Alert Category

System - Other

### SNMP Trap ID

22

### CIM Information

**Prefix:** PLAT ID: 0142

## User Response

Complete the following steps:

1. Check the CMM or FSM event log for any fan or cooling related issues.
2. Make sure that the airflow at the front and rear of the chassis is not obstructed and that fillers are in place and correctly installed.
3. Make sure that the room temperature is within operating specifications.
4. Make sure that the DIMM baffles are in place.
5. If the problem persists and there are no other DIMMs with the same indication, replace the DIMM.

- **806f090c-202bffff : [PhysicalMemoryElementName] on Subsystem [MemoryElementName] Throttled.**

Memory has been Throttled.

### Severity

Warning

### Serviceable

Yes

### Automatically notify support

No

**Alert Category**

System - Other

**SNMP Trap ID**

22

**CIM Information**

**Prefix:** PLAT ID: 0142

**User Response**

Complete the following steps:

1. Check the CMM or FSM event log for any fan or cooling related issues.
  2. Make sure that the airflow at the front and rear of the chassis is not obstructed and that fillers are in place and correctly installed.
  3. Make sure that the room temperature is within operating specifications.
  4. Make sure that the DIMM baffles are in place.
  5. If the problem persists and there are no other DIMMs with the same indication, replace the DIMM.
- **806f090c-202cffff : [PhysicalMemoryElementName] on Subsystem [MemoryElementName] Throttled.**

Memory has been Throttled.

**Severity**

Warning

**Serviceable**

Yes

**Automatically notify support**

No

**Alert Category**

System - Other

**SNMP Trap ID**

22

**CIM Information**

**Prefix:** PLAT ID: 0142

**User Response**

Complete the following steps:

1. Check the CMM or FSM event log for any fan or cooling related issues.
  2. Make sure that the airflow at the front and rear of the chassis is not obstructed and that fillers are in place and correctly installed.
  3. Make sure that the room temperature is within operating specifications.
  4. Make sure that the DIMM baffles are in place.
  5. If the problem persists and there are no other DIMMs with the same indication, replace the DIMM.
- **806f090c-202dffff : [PhysicalMemoryElementName] on Subsystem [MemoryElementName] Throttled.**

Memory has been Throttled.

**Severity**

Warning

**Serviceable**

Yes

**Automatically notify support**

No

**Alert Category**

System - Other

**SNMP Trap ID**

22

**CIM Information**

**Prefix: PLAT ID:** 0142

**User Response**

Complete the following steps:

1. Check the CMM or FSM event log for any fan or cooling related issues.
2. Make sure that the airflow at the front and rear of the chassis is not obstructed and that fillers are in place and correctly installed.
3. Make sure that the room temperature is within operating specifications.
4. Make sure that the DIMM baffles are in place.
5. If the problem persists and there are no other DIMMs with the same indication, replace the DIMM.

- **806f090c-202effff : [PhysicalMemoryElementName] on Subsystem [MemoryElementName] Throttled.**

Memory has been Throttled.

**Severity**

Warning

**Serviceable**

Yes

**Automatically notify support**

No

**Alert Category**

System - Other

**SNMP Trap ID**

22

**CIM Information**

**Prefix: PLAT ID:** 0142

**User Response**

Complete the following steps:

1. Check the CMM or FSM event log for any fan or cooling related issues.
2. Make sure that the airflow at the front and rear of the chassis is not obstructed and that fillers are in place and correctly installed.
3. Make sure that the room temperature is within operating specifications.

4. Make sure that the DIMM baffles are in place.
5. If the problem persists and there are no other DIMMs with the same indication, replace the DIMM.

- **806f090c-202ffff : [PhysicalMemoryElementName] on Subsystem [MemoryElementName] Throttled.**

Memory has been Throttled.

**Severity**

Warning

**Serviceable**

Yes

**Automatically notify support**

No

**Alert Category**

System - Other

**SNMP Trap ID**

22

**CIM Information**

**Prefix:** PLAT ID: 0142

**User Response**

Complete the following steps:

1. Check the CMM or FSM event log for any fan or cooling related issues.
2. Make sure that the airflow at the front and rear of the chassis is not obstructed and that fillers are in place and correctly installed.
3. Make sure that the room temperature is within operating specifications.
4. Make sure that the DIMM baffles are in place.
5. If the problem persists and there are no other DIMMs with the same indication, replace the DIMM.

- **806f090c-2030fff : [PhysicalMemoryElementName] on Subsystem [MemoryElementName] Throttled.**

Memory has been Throttled.

**Severity**

Warning

**Serviceable**

Yes

**Automatically notify support**

No

**Alert Category**

System - Other

**SNMP Trap ID**

22

**CIM Information**

**Prefix:** PLAT ID: 0142

**User Response**

Complete the following steps:

1. Check the CMM or FSM event log for any fan or cooling related issues.
2. Make sure that the airflow at the front and rear of the chassis is not obstructed and that fillers are in place and correctly installed.
3. Make sure that the room temperature is within operating specifications.
4. Make sure that the DIMM baffles are in place.
5. If the problem persists and there are no other DIMMs with the same indication, replace the DIMM.

- **806f0a07-0301ffff : CPU 1 is operating in a Degraded State.**

The processor is being throttled due to thermal or power conditions.

**Severity**

Warning

**Serviceable**

Yes

**Automatically notify support**

No

**Alert Category**

Warning - CPU

**SNMP Trap ID**

42

**CIM Information**

**Prefix: PLAT ID:** 0038

**User Response**

Complete the following steps:

1. Check the CMM or FSM event log for any fan- or cooling-related issues or power-related issues..
2. Make sure that the airflow at the front and rear of the chassis is not obstructed and that fillers are in place and correctly installed.
3. Make sure that the room temperature is within operating specifications.

- **806f0a07-0302ffff : CPU 2 is operating in a Degraded State.**

The processor is being throttled due to thermal or power conditions.

**Severity**

Warning

**Serviceable**

Yes

**Automatically notify support**

No

**Alert Category**

Warning - CPU

**SNMP Trap ID**

42

**CIM Information**

**Prefix: PLAT ID:** 0038

## User Response

Complete the following steps:

1. Check the CMM or FSM event log for any fan- or cooling-related issues or power-related issues..
  2. Make sure that the airflow at the front and rear of the chassis is not obstructed and that fillers are in place and correctly installed.
  3. Make sure that the room temperature is within operating specifications.
- **806f0a07-0303ffff : [ProcessorElementName] is operating in a Degraded State.**

The processor is being throttled due to thermal or power conditions.

### Severity

Warning

### Serviceable

Yes

### Automatically notify support

No

### Alert Category

Warning - CPU

### SNMP Trap ID

42

### CIM Information

Prefix: PLAT ID: 0038

## User Response

Complete the following steps:

1. Check the CMM or FSM event log for any fan- or cooling-related issues or power-related issues..
  2. Make sure that the airflow at the front and rear of the chassis is not obstructed and that fillers are in place and correctly installed.
  3. Make sure that the room temperature is within operating specifications.
- **806f0a07-0304ffff : [ProcessorElementName] is operating in a Degraded State.**

The processor is being throttled due to thermal or power conditions.

### Severity

Warning

### Serviceable

Yes

### Automatically notify support

No

### Alert Category

Warning - CPU

### SNMP Trap ID

42

### CIM Information

Prefix: PLAT ID: 0038

## User Response

Complete the following steps:

1. Check the CMM or FSM event log for any fan- or cooling-related issues or power-related issues..
  2. Make sure that the airflow at the front and rear of the chassis is not obstructed and that fillers are in place and correctly installed.
  3. Make sure that the room temperature is within operating specifications.
- **806f0a07-2584ffff : [ProcessorElementName] is operating in a Degraded State.**  
Processor(s) are being throttled due to thermal or power conditions.

**Severity**

Warning

**Serviceable**

Yes

**Automatically notify support**

No

**Alert Category**

Warning - CPU

**SNMP Trap ID**

42

**CIM Information**

Prefix: PLAT ID: 0038

**User Response**

Complete the following steps:

1. Check the CMM or FSM event log for any fan- or cooling-related issues or power-related issues..
  2. Make sure that the airflow at the front and rear of the chassis is not obstructed and that fillers are in place and correctly installed.
  3. Make sure that the room temperature is within operating specifications.
- **806f0a0c-2001ffff : An Over-Temperature Condition has been detected on the [PhysicalMemoryElementName] on Subsystem [MemoryElementName].**  
An over temperature condition for memory has been detected.

**Severity**

Error

**Serviceable**

Yes

**Automatically notify support**

No

**Alert Category**

Critical - Temperature

**SNMP Trap ID**

0

**CIM Information**

Prefix: PLAT ID: 0146

**User Response**

Complete the following steps:



1. Check the CMM or FSM event log for any fan or cooling related issues.
  2. Make sure that the airflow at the front and rear of the chassis is not obstructed and that fillers are in place and correctly installed.
  3. Make sure that the room temperature is within operating specifications.
  4. Make sure that the DIMM baffles are in place.
  5. If the problem persists and there are no other DIMMs with the same indication, replace the DIMM.
- **806f0a0c-2002ffff : An Over-Temperature Condition has been detected on the [PhysicalMemoryElementName] on Subsystem [MemoryElementName].**

An over temperature condition for memory has been detected.

**Severity**

Error

**Serviceable**

Yes

**Automatically notify support**

No

**Alert Category**

Critical - Temperature

**SNMP Trap ID**

0

**CIM Information**

**Prefix:** PLAT ID: 0146

**User Response**

Complete the following steps:

1. Check the CMM or FSM event log for any fan or cooling related issues.
  2. Make sure that the airflow at the front and rear of the chassis is not obstructed and that fillers are in place and correctly installed.
  3. Make sure that the room temperature is within operating specifications.
  4. Make sure that the DIMM baffles are in place.
  5. If the problem persists and there are no other DIMMs with the same indication, replace the DIMM.
- **806f0a0c-2003ffff : An Over-Temperature Condition has been detected on the [PhysicalMemoryElementName] on Subsystem [MemoryElementName].**

An over temperature condition for memory has been detected.

**Severity**

Error

**Serviceable**

Yes

**Automatically notify support**

No

**Alert Category**

Critical - Temperature

**SNMP Trap ID**

0

#### CIM Information

Prefix: PLAT ID: 0146

#### User Response

Complete the following steps:

1. Check the CMM or FSM event log for any fan or cooling related issues.
  2. Make sure that the airflow at the front and rear of the chassis is not obstructed and that fillers are in place and correctly installed.
  3. Make sure that the room temperature is within operating specifications.
  4. Make sure that the DIMM baffles are in place.
  5. If the problem persists and there are no other DIMMs with the same indication, replace the DIMM.
- **806f0a0c-2004ffff : An Over-Temperature Condition has been detected on the [PhysicalMemoryElementName] on Subsystem [MemoryElementName].**

An over temperature condition for memory has been detected.

#### Severity

Error

#### Serviceable

Yes

#### Automatically notify support

No

#### Alert Category

Critical - Temperature

#### SNMP Trap ID

0

#### CIM Information

Prefix: PLAT ID: 0146

#### User Response

Complete the following steps:

1. Check the CMM or FSM event log for any fan or cooling related issues.
  2. Make sure that the airflow at the front and rear of the chassis is not obstructed and that fillers are in place and correctly installed.
  3. Make sure that the room temperature is within operating specifications.
  4. Make sure that the DIMM baffles are in place.
  5. If the problem persists and there are no other DIMMs with the same indication, replace the DIMM.
- **806f0a0c-2005ffff : An Over-Temperature Condition has been detected on the [PhysicalMemoryElementName] on Subsystem [MemoryElementName].**

An over temperature condition for memory has been detected.

#### Severity

Error

#### Serviceable

Yes

**Automatically notify support**

No

**Alert Category**

Critical - Temperature

**SNMP Trap ID**

0

**CIM Information**

**Prefix:** PLAT ID: 0146

**User Response**

Complete the following steps:

1. Check the CMM or FSM event log for any fan or cooling related issues.
2. Make sure that the airflow at the front and rear of the chassis is not obstructed and that fillers are in place and correctly installed.
3. Make sure that the room temperature is within operating specifications.
4. Make sure that the DIMM baffles are in place.
5. If the problem persists and there are no other DIMMs with the same indication, replace the DIMM.

- **806f0a0c-2006ffff : An Over-Temperature Condition has been detected on the [PhysicalMemoryElementName] on Subsystem [MemoryElementName].**

An over temperature condition for memory has been detected.

**Severity**

Error

**Serviceable**

Yes

**Automatically notify support**

No

**Alert Category**

Critical - Temperature

**SNMP Trap ID**

0

**CIM Information**

**Prefix:** PLAT ID: 0146

**User Response**

Complete the following steps:

1. Check the CMM or FSM event log for any fan or cooling related issues.
2. Make sure that the airflow at the front and rear of the chassis is not obstructed and that fillers are in place and correctly installed.
3. Make sure that the room temperature is within operating specifications.
4. Make sure that the DIMM baffles are in place.
5. If the problem persists and there are no other DIMMs with the same indication, replace the DIMM.

- **806f0a0c-2007ffff : An Over-Temperature Condition has been detected on the [PhysicalMemoryElementName] on Subsystem [MemoryElementName].**

An over temperature condition for memory has been detected.

**Severity**

Error

**Serviceable**

Yes

**Automatically notify support**

No

**Alert Category**

Critical - Temperature

**SNMP Trap ID**

0

**CIM Information**

Prefix: PLAT ID: 0146

**User Response**

Complete the following steps:

1. Check the CMM or FSM event log for any fan or cooling related issues.
2. Make sure that the airflow at the front and rear of the chassis is not obstructed and that fillers are in place and correctly installed.
3. Make sure that the room temperature is within operating specifications.
4. Make sure that the DIMM baffles are in place.
5. If the problem persists and there are no other DIMMs with the same indication, replace the DIMM.

- **806f0a0c-2008ffff : An Over-Temperature Condition has been detected on the [PhysicalMemoryElementName] on Subsystem [MemoryElementName].**

An over temperature condition for memory has been detected.

**Severity**

Error

**Serviceable**

Yes

**Automatically notify support**

No

**Alert Category**

Critical - Temperature

**SNMP Trap ID**

0

**CIM Information**

Prefix: PLAT ID: 0146

**User Response**

Complete the following steps:

1. Check the CMM or FSM event log for any fan or cooling related issues.

2. Make sure that the airflow at the front and rear of the chassis is not obstructed and that fillers are in place and correctly installed.
  3. Make sure that the room temperature is within operating specifications.
  4. Make sure that the DIMM baffles are in place.
  5. If the problem persists and there are no other DIMMs with the same indication, replace the DIMM.
- **806f0a0c-2009ffff : An Over-Temperature Condition has been detected on the [PhysicalMemoryElementName] on Subsystem [MemoryElementName].**  
An over temperature condition for memory has been detected.

**Severity**

Error

**Serviceable**

Yes

**Automatically notify support**

No

**Alert Category**

Critical - Temperature

**SNMP Trap ID**

0

**CIM Information**

**Prefix: PLAT ID:** 0146

**User Response**

Complete the following steps:

1. Check the CMM or FSM event log for any fan or cooling related issues.
  2. Make sure that the airflow at the front and rear of the chassis is not obstructed and that fillers are in place and correctly installed.
  3. Make sure that the room temperature is within operating specifications.
  4. Make sure that the DIMM baffles are in place.
  5. If the problem persists and there are no other DIMMs with the same indication, replace the DIMM.
- **806f0a0c-200affff : An Over-Temperature Condition has been detected on the [PhysicalMemoryElementName] on Subsystem [MemoryElementName].**  
An over temperature condition for memory has been detected.

**Severity**

Error

**Serviceable**

Yes

**Automatically notify support**

No

**Alert Category**

Critical - Temperature

**SNMP Trap ID**

0

## CIM Information

Prefix: PLAT ID: 0146

## User Response

Complete the following steps:

1. Check the CMM or FSM event log for any fan or cooling related issues.
2. Make sure that the airflow at the front and rear of the chassis is not obstructed and that fillers are in place and correctly installed.
3. Make sure that the room temperature is within operating specifications.
4. Make sure that the DIMM baffles are in place.
5. If the problem persists and there are no other DIMMs with the same indication, replace the DIMM.

- **806f0a0c-200bffff : An Over-Temperature Condition has been detected on the [PhysicalMemoryElementName] on Subsystem [MemoryElementName].**

An over temperature condition for memory has been detected.

## Severity

Error

## Serviceable

Yes

## Automatically notify support

No

## Alert Category

Critical - Temperature

## SNMP Trap ID

0

## CIM Information

Prefix: PLAT ID: 0146

## User Response

Complete the following steps:

1. Check the CMM or FSM event log for any fan or cooling related issues.
2. Make sure that the airflow at the front and rear of the chassis is not obstructed and that fillers are in place and correctly installed.
3. Make sure that the room temperature is within operating specifications.
4. Make sure that the DIMM baffles are in place.
5. If the problem persists and there are no other DIMMs with the same indication, replace the DIMM.

- **806f0a0c-200cffff : An Over-Temperature Condition has been detected on the [PhysicalMemoryElementName] on Subsystem [MemoryElementName].**

An over temperature condition for memory has been detected.

## Severity

Error

## Serviceable

Yes

**Automatically notify support**

No

**Alert Category**

Critical - Temperature

**SNMP Trap ID**

0

**CIM Information**

**Prefix:** PLAT ID: 0146

**User Response**

Complete the following steps:

1. Check the CMM or FSM event log for any fan or cooling related issues.
2. Make sure that the airflow at the front and rear of the chassis is not obstructed and that fillers are in place and correctly installed.
3. Make sure that the room temperature is within operating specifications.
4. Make sure that the DIMM baffles are in place.
5. If the problem persists and there are no other DIMMs with the same indication, replace the DIMM.

- **806f0a0c-200dffff : An Over-Temperature Condition has been detected on the [PhysicalMemoryElementName] on Subsystem [MemoryElementName].**

An over temperature condition for memory has been detected.

**Severity**

Error

**Serviceable**

Yes

**Automatically notify support**

No

**Alert Category**

Critical - Temperature

**SNMP Trap ID**

0

**CIM Information**

**Prefix:** PLAT ID: 0146

**User Response**

Complete the following steps:

1. Check the CMM or FSM event log for any fan or cooling related issues.
2. Make sure that the airflow at the front and rear of the chassis is not obstructed and that fillers are in place and correctly installed.
3. Make sure that the room temperature is within operating specifications.
4. Make sure that the DIMM baffles are in place.
5. If the problem persists and there are no other DIMMs with the same indication, replace the DIMM.

- **806f0a0c-200effff : An Over-Temperature Condition has been detected on the [PhysicalMemoryElementName] on Subsystem [MemoryElementName].**

An over temperature condition for memory has been detected.

**Severity**

Error

**Serviceable**

Yes

**Automatically notify support**

No

**Alert Category**

Critical - Temperature

**SNMP Trap ID**

0

**CIM Information**

**Prefix: PLAT ID:** 0146

**User Response**

Complete the following steps:

1. Check the CMM or FSM event log for any fan or cooling related issues.
2. Make sure that the airflow at the front and rear of the chassis is not obstructed and that fillers are in place and correctly installed.
3. Make sure that the room temperature is within operating specifications.
4. Make sure that the DIMM baffles are in place.
5. If the problem persists and there are no other DIMMs with the same indication, replace the DIMM.

- **806f0a0c-200ffff : An Over-Temperature Condition has been detected on the [PhysicalMemoryElementName] on Subsystem [MemoryElementName].**

An over temperature condition for memory has been detected.

**Severity**

Error

**Serviceable**

Yes

**Automatically notify support**

No

**Alert Category**

Critical - Temperature

**SNMP Trap ID**

0

**CIM Information**

**Prefix: PLAT ID:** 0146

**User Response**

Complete the following steps:

1. Check the CMM or FSM event log for any fan or cooling related issues.
2. Make sure that the airflow at the front and rear of the chassis is not obstructed and that fillers are in place and correctly installed.



3. Make sure that the room temperature is within operating specifications.
4. Make sure that the DIMM baffles are in place.
5. If the problem persists and there are no other DIMMs with the same indication, replace the DIMM.

- **806f0a0c-2010ffff : An Over-Temperature Condition has been detected on the [PhysicalMemoryElementName] on Subsystem [MemoryElementName].**

An over temperature condition for memory has been detected.

**Severity**

Error

**Serviceable**

Yes

**Automatically notify support**

No

**Alert Category**

Critical - Temperature

**SNMP Trap ID**

0

**CIM Information**

**Prefix:** PLAT ID: 0146

**User Response**

Complete the following steps:

1. Check the CMM or FSM event log for any fan or cooling related issues.
2. Make sure that the airflow at the front and rear of the chassis is not obstructed and that fillers are in place and correctly installed.
3. Make sure that the room temperature is within operating specifications.
4. Make sure that the DIMM baffles are in place.
5. If the problem persists and there are no other DIMMs with the same indication, replace the DIMM.

- **806f0a0c-2011ffff : An Over-Temperature Condition has been detected on the [PhysicalMemoryElementName] on Subsystem [MemoryElementName].**

An over temperature condition for memory has been detected.

**Severity**

Error

**Serviceable**

Yes

**Automatically notify support**

No

**Alert Category**

Critical - Temperature

**SNMP Trap ID**

0

**CIM Information**

**Prefix:** PLAT ID: 0146

## User Response

Complete the following steps:

1. Check the CMM or FSM event log for any fan or cooling related issues.
  2. Make sure that the airflow at the front and rear of the chassis is not obstructed and that fillers are in place and correctly installed.
  3. Make sure that the room temperature is within operating specifications.
  4. Make sure that the DIMM baffles are in place.
  5. If the problem persists and there are no other DIMMs with the same indication, replace the DIMM.
- **806f0a0c-2012ffff : An Over-Temperature Condition has been detected on the [PhysicalMemoryElementName] on Subsystem [MemoryElementName].**  
An over temperature condition for memory has been detected.

### Severity

Error

### Serviceable

Yes

### Automatically notify support

No

### Alert Category

Critical - Temperature

### SNMP Trap ID

0

### CIM Information

**Prefix:** PLAT ID: 0146

## User Response

Complete the following steps:

1. Check the CMM or FSM event log for any fan or cooling related issues.
  2. Make sure that the airflow at the front and rear of the chassis is not obstructed and that fillers are in place and correctly installed.
  3. Make sure that the room temperature is within operating specifications.
  4. Make sure that the DIMM baffles are in place.
  5. If the problem persists and there are no other DIMMs with the same indication, replace the DIMM.
- **806f0a0c-2013ffff : An Over-Temperature Condition has been detected on the [PhysicalMemoryElementName] on Subsystem [MemoryElementName].**  
An over temperature condition for memory has been detected.

### Severity

Error

### Serviceable

Yes

### Automatically notify support

No

**Alert Category**

Critical - Temperature

**SNMP Trap ID**

0

**CIM Information**

**Prefix:** PLAT ID: 0146

**User Response**

Complete the following steps:

1. Check the CMM or FSM event log for any fan or cooling related issues.
  2. Make sure that the airflow at the front and rear of the chassis is not obstructed and that fillers are in place and correctly installed.
  3. Make sure that the room temperature is within operating specifications.
  4. Make sure that the DIMM baffles are in place.
  5. If the problem persists and there are no other DIMMs with the same indication, replace the DIMM.
- **806f0a0c-2014ffff : An Over-Temperature Condition has been detected on the [PhysicalMemoryElementName] on Subsystem [MemoryElementName].**  
An over temperature condition for memory has been detected.

**Severity**

Error

**Serviceable**

Yes

**Automatically notify support**

No

**Alert Category**

Critical - Temperature

**SNMP Trap ID**

0

**CIM Information**

**Prefix:** PLAT ID: 0146

**User Response**

Complete the following steps:

1. Check the CMM or FSM event log for any fan or cooling related issues.
  2. Make sure that the airflow at the front and rear of the chassis is not obstructed and that fillers are in place and correctly installed.
  3. Make sure that the room temperature is within operating specifications.
  4. Make sure that the DIMM baffles are in place.
  5. If the problem persists and there are no other DIMMs with the same indication, replace the DIMM.
- **806f0a0c-2015ffff : An Over-Temperature Condition has been detected on the [PhysicalMemoryElementName] on Subsystem [MemoryElementName].**  
An over temperature condition for memory has been detected.

**Severity**

Error

**Serviceable**

Yes

**Automatically notify support**

No

**Alert Category**

Critical - Temperature

**SNMP Trap ID**

0

**CIM Information**

**Prefix: PLAT ID:** 0146

**User Response**

Complete the following steps:

1. Check the CMM or FSM event log for any fan or cooling related issues.
2. Make sure that the airflow at the front and rear of the chassis is not obstructed and that fillers are in place and correctly installed.
3. Make sure that the room temperature is within operating specifications.
4. Make sure that the DIMM baffles are in place.
5. If the problem persists and there are no other DIMMs with the same indication, replace the DIMM.

- **806f0a0c-2016ffff : An Over-Temperature Condition has been detected on the [PhysicalMemoryElementName] on Subsystem [MemoryElementName].**

An over temperature condition for memory has been detected.

**Severity**

Error

**Serviceable**

Yes

**Automatically notify support**

No

**Alert Category**

Critical - Temperature

**SNMP Trap ID**

0

**CIM Information**

**Prefix: PLAT ID:** 0146

**User Response**

Complete the following steps:

1. Check the CMM or FSM event log for any fan or cooling related issues.
2. Make sure that the airflow at the front and rear of the chassis is not obstructed and that fillers are in place and correctly installed.
3. Make sure that the room temperature is within operating specifications.

4. Make sure that the DIMM baffles are in place.
  5. If the problem persists and there are no other DIMMs with the same indication, replace the DIMM.
- **806f0a0c-2017ffff : An Over-Temperature Condition has been detected on the [PhysicalMemoryElementName] on Subsystem [MemoryElementName].**  
An over temperature condition for memory has been detected.

**Severity**

Error

**Serviceable**

Yes

**Automatically notify support**

No

**Alert Category**

Critical - Temperature

**SNMP Trap ID**

0

**CIM Information**

**Prefix:** PLAT ID: 0146

**User Response**

Complete the following steps:

1. Check the CMM or FSM event log for any fan or cooling related issues.
  2. Make sure that the airflow at the front and rear of the chassis is not obstructed and that fillers are in place and correctly installed.
  3. Make sure that the room temperature is within operating specifications.
  4. Make sure that the DIMM baffles are in place.
  5. If the problem persists and there are no other DIMMs with the same indication, replace the DIMM.
- **806f0a0c-2018ffff : An Over-Temperature Condition has been detected on the [PhysicalMemoryElementName] on Subsystem [MemoryElementName].**  
An over temperature condition for memory has been detected.

**Severity**

Error

**Serviceable**

Yes

**Automatically notify support**

No

**Alert Category**

Critical - Temperature

**SNMP Trap ID**

0

**CIM Information**

**Prefix:** PLAT ID: 0146

**User Response**

Complete the following steps:

1. Check the CMM or FSM event log for any fan or cooling related issues.
2. Make sure that the airflow at the front and rear of the chassis is not obstructed and that fillers are in place and correctly installed.
3. Make sure that the room temperature is within operating specifications.
4. Make sure that the DIMM baffles are in place.
5. If the problem persists and there are no other DIMMs with the same indication, replace the DIMM.

- **806f0a0c-2019ffff : An Over-Temperature Condition has been detected on the [PhysicalMemoryElementName] on Subsystem [MemoryElementName].**

An over temperature condition for memory has been detected.

**Severity**

Error

**Serviceable**

Yes

**Automatically notify support**

No

**Alert Category**

Critical - Temperature

**SNMP Trap ID**

0

**CIM Information**

**Prefix: PLAT ID:** 0146

**User Response**

Complete the following steps:

1. Check the CMM or FSM event log for any fan or cooling related issues.
2. Make sure that the airflow at the front and rear of the chassis is not obstructed and that fillers are in place and correctly installed.
3. Make sure that the room temperature is within operating specifications.
4. Make sure that the DIMM baffles are in place.
5. If the problem persists and there are no other DIMMs with the same indication, replace the DIMM.

- **806f0a0c-201affff : An Over-Temperature Condition has been detected on the [PhysicalMemoryElementName] on Subsystem [MemoryElementName].**

An over temperature condition for memory has been detected.

**Severity**

Error

**Serviceable**

Yes

**Automatically notify support**

No

**Alert Category**

Critical - Temperature

**SNMP Trap ID**

0

**CIM Information****Prefix:** PLAT ID: 0146**User Response**

Complete the following steps:

1. Check the CMM or FSM event log for any fan or cooling related issues.
  2. Make sure that the airflow at the front and rear of the chassis is not obstructed and that fillers are in place and correctly installed.
  3. Make sure that the room temperature is within operating specifications.
  4. Make sure that the DIMM baffles are in place.
  5. If the problem persists and there are no other DIMMs with the same indication, replace the DIMM.
- **806f0a0c-201bffff : An Over-Temperature Condition has been detected on the [PhysicalMemoryElementName] on Subsystem [MemoryElementName].**

An over temperature condition for memory has been detected.

**Severity**

Error

**Serviceable**

Yes

**Automatically notify support**

No

**Alert Category**

Critical - Temperature

**SNMP Trap ID**

0

**CIM Information****Prefix:** PLAT ID: 0146**User Response**

Complete the following steps:

1. Check the CMM or FSM event log for any fan or cooling related issues.
  2. Make sure that the airflow at the front and rear of the chassis is not obstructed and that fillers are in place and correctly installed.
  3. Make sure that the room temperature is within operating specifications.
  4. Make sure that the DIMM baffles are in place.
  5. If the problem persists and there are no other DIMMs with the same indication, replace the DIMM.
- **806f0a0c-201cffff : An Over-Temperature Condition has been detected on the [PhysicalMemoryElementName] on Subsystem [MemoryElementName].**

An over temperature condition for memory has been detected.

**Severity**

Error

**Serviceable**

Yes

**Automatically notify support**

No

**Alert Category**

Critical - Temperature

**SNMP Trap ID**

0

**CIM Information**

**Prefix:** PLAT ID: 0146

**User Response**

Complete the following steps:

1. Check the CMM or FSM event log for any fan or cooling related issues.
2. Make sure that the airflow at the front and rear of the chassis is not obstructed and that fillers are in place and correctly installed.
3. Make sure that the room temperature is within operating specifications.
4. Make sure that the DIMM baffles are in place.
5. If the problem persists and there are no other DIMMs with the same indication, replace the DIMM.

- **806f0a0c-201dffff : An Over-Temperature Condition has been detected on the [PhysicalMemoryElementName] on Subsystem [MemoryElementName].**

An over temperature condition for memory has been detected.

**Severity**

Error

**Serviceable**

Yes

**Automatically notify support**

No

**Alert Category**

Critical - Temperature

**SNMP Trap ID**

0

**CIM Information**

**Prefix:** PLAT ID: 0146

**User Response**

Complete the following steps:

1. Check the CMM or FSM event log for any fan or cooling related issues.
2. Make sure that the airflow at the front and rear of the chassis is not obstructed and that fillers are in place and correctly installed.
3. Make sure that the room temperature is within operating specifications.
4. Make sure that the DIMM baffles are in place.
5. If the problem persists and there are no other DIMMs with the same indication, replace the DIMM.



- **806f0a0c-201efff : An Over-Temperature Condition has been detected on the [PhysicalMemoryElementName] on Subsystem [MemoryElementName].**

An over temperature condition for memory has been detected.

**Severity**

Error

**Serviceable**

Yes

**Automatically notify support**

No

**Alert Category**

Critical - Temperature

**SNMP Trap ID**

0

**CIM Information**

Prefix: PLAT ID: 0146

**User Response**

Complete the following steps:

1. Check the CMM or FSM event log for any fan or cooling related issues.
2. Make sure that the airflow at the front and rear of the chassis is not obstructed and that fillers are in place and correctly installed.
3. Make sure that the room temperature is within operating specifications.
4. Make sure that the DIMM baffles are in place.
5. If the problem persists and there are no other DIMMs with the same indication, replace the DIMM.

- **806f0a0c-201ffff : An Over-Temperature Condition has been detected on the [PhysicalMemoryElementName] on Subsystem [MemoryElementName].**

An over temperature condition for memory has been detected.

**Severity**

Error

**Serviceable**

Yes

**Automatically notify support**

No

**Alert Category**

Critical - Temperature

**SNMP Trap ID**

0

**CIM Information**

Prefix: PLAT ID: 0146

**User Response**

Complete the following steps:

1. Check the CMM or FSM event log for any fan or cooling related issues.

2. Make sure that the airflow at the front and rear of the chassis is not obstructed and that fillers are in place and correctly installed.
  3. Make sure that the room temperature is within operating specifications.
  4. Make sure that the DIMM baffles are in place.
  5. If the problem persists and there are no other DIMMs with the same indication, replace the DIMM.
- **806f0a0c-2020ffff : An Over-Temperature Condition has been detected on the [PhysicalMemoryElementName] on Subsystem [MemoryElementName].**  
An over temperature condition for memory has been detected.

**Severity**

Error

**Serviceable**

Yes

**Automatically notify support**

No

**Alert Category**

Critical - Temperature

**SNMP Trap ID**

0

**CIM Information**

Prefix: PLAT ID: 0146

**User Response**

Complete the following steps:

1. Check the CMM or FSM event log for any fan or cooling related issues.
  2. Make sure that the airflow at the front and rear of the chassis is not obstructed and that fillers are in place and correctly installed.
  3. Make sure that the room temperature is within operating specifications.
  4. Make sure that the DIMM baffles are in place.
  5. If the problem persists and there are no other DIMMs with the same indication, replace the DIMM.
- **806f0a0c-2021ffff : An Over-Temperature Condition has been detected on the [PhysicalMemoryElementName] on Subsystem [MemoryElementName].**  
An over temperature condition for memory has been detected.

**Severity**

Error

**Serviceable**

Yes

**Automatically notify support**

No

**Alert Category**

Critical - Temperature

**SNMP Trap ID**

0

**CIM Information**

Prefix: PLAT ID: 0146

**User Response**

Complete the following steps:

1. Check the CMM or FSM event log for any fan or cooling related issues.
2. Make sure that the airflow at the front and rear of the chassis is not obstructed and that fillers are in place and correctly installed.
3. Make sure that the room temperature is within operating specifications.
4. Make sure that the DIMM baffles are in place.
5. If the problem persists and there are no other DIMMs with the same indication, replace the DIMM.

- **806f0a0c-2022ffff : An Over-Temperature Condition has been detected on the [PhysicalMemoryElementName] on Subsystem [MemoryElementName].**

An over temperature condition for memory has been detected.

**Severity**

Error

**Serviceable**

Yes

**Automatically notify support**

No

**Alert Category**

Critical - Temperature

**SNMP Trap ID**

0

**CIM Information**

Prefix: PLAT ID: 0146

**User Response**

Complete the following steps:

1. Check the CMM or FSM event log for any fan or cooling related issues.
2. Make sure that the airflow at the front and rear of the chassis is not obstructed and that fillers are in place and correctly installed.
3. Make sure that the room temperature is within operating specifications.
4. Make sure that the DIMM baffles are in place.
5. If the problem persists and there are no other DIMMs with the same indication, replace the DIMM.

- **806f0a0c-2023ffff : An Over-Temperature Condition has been detected on the [PhysicalMemoryElementName] on Subsystem [MemoryElementName].**

An over temperature condition for memory has been detected.

**Severity**

Error

**Serviceable**

Yes

**Automatically notify support**

No

**Alert Category**

Critical - Temperature

**SNMP Trap ID**

0

**CIM Information**

**Prefix: PLAT ID:** 0146

**User Response**

Complete the following steps:

1. Check the CMM or FSM event log for any fan or cooling related issues.
2. Make sure that the airflow at the front and rear of the chassis is not obstructed and that fillers are in place and correctly installed.
3. Make sure that the room temperature is within operating specifications.
4. Make sure that the DIMM baffles are in place.
5. If the problem persists and there are no other DIMMs with the same indication, replace the DIMM.

- **806f0a0c-2024ffff : An Over-Temperature Condition has been detected on the [PhysicalMemoryElementName] on Subsystem [MemoryElementName].**

An over temperature condition for memory has been detected.

**Severity**

Error

**Serviceable**

Yes

**Automatically notify support**

No

**Alert Category**

Critical - Temperature

**SNMP Trap ID**

0

**CIM Information**

**Prefix: PLAT ID:** 0146

**User Response**

Complete the following steps:

1. Check the CMM or FSM event log for any fan or cooling related issues.
2. Make sure that the airflow at the front and rear of the chassis is not obstructed and that fillers are in place and correctly installed.
3. Make sure that the room temperature is within operating specifications.
4. Make sure that the DIMM baffles are in place.
5. If the problem persists and there are no other DIMMs with the same indication, replace the DIMM.

- **806f0a0c-2025ffff : An Over-Temperature Condition has been detected on the [PhysicalMemoryElementName] on Subsystem [MemoryElementName].**

An over temperature condition for memory has been detected.

**Severity**

Error

**Serviceable**

Yes

**Automatically notify support**

No

**Alert Category**

Critical - Temperature

**SNMP Trap ID**

0

**CIM Information**

**Prefix: PLAT ID:** 0146

**User Response**

Complete the following steps:

1. Check the CMM or FSM event log for any fan or cooling related issues.
2. Make sure that the airflow at the front and rear of the chassis is not obstructed and that fillers are in place and correctly installed.
3. Make sure that the room temperature is within operating specifications.
4. Make sure that the DIMM baffles are in place.
5. If the problem persists and there are no other DIMMs with the same indication, replace the DIMM.

- **806f0a0c-2026ffff : An Over-Temperature Condition has been detected on the [PhysicalMemoryElementName] on Subsystem [MemoryElementName].**

An over temperature condition for memory has been detected.

**Severity**

Error

**Serviceable**

Yes

**Automatically notify support**

No

**Alert Category**

Critical - Temperature

**SNMP Trap ID**

0

**CIM Information**

**Prefix: PLAT ID:** 0146

**User Response**

Complete the following steps:

1. Check the CMM or FSM event log for any fan or cooling related issues.
2. Make sure that the airflow at the front and rear of the chassis is not obstructed and that fillers are in place and correctly installed.

3. Make sure that the room temperature is within operating specifications.
  4. Make sure that the DIMM baffles are in place.
  5. If the problem persists and there are no other DIMMs with the same indication, replace the DIMM.
- **806f0a0c-2027ffff : An Over-Temperature Condition has been detected on the [PhysicalMemoryElementName] on Subsystem [MemoryElementName].**

An over temperature condition for memory has been detected.

**Severity**

Error

**Serviceable**

Yes

**Automatically notify support**

No

**Alert Category**

Critical - Temperature

**SNMP Trap ID**

0

**CIM Information**

**Prefix: PLAT ID:** 0146

**User Response**

Complete the following steps:

1. Check the CMM or FSM event log for any fan or cooling related issues.
  2. Make sure that the airflow at the front and rear of the chassis is not obstructed and that fillers are in place and correctly installed.
  3. Make sure that the room temperature is within operating specifications.
  4. Make sure that the DIMM baffles are in place.
  5. If the problem persists and there are no other DIMMs with the same indication, replace the DIMM.
- **806f0a0c-2028ffff : An Over-Temperature Condition has been detected on the [PhysicalMemoryElementName] on Subsystem [MemoryElementName].**

An over temperature condition for memory has been detected.

**Severity**

Error

**Serviceable**

Yes

**Automatically notify support**

No

**Alert Category**

Critical - Temperature

**SNMP Trap ID**

0

**CIM Information**

**Prefix: PLAT ID:** 0146

## User Response

Complete the following steps:

1. Check the CMM or FSM event log for any fan or cooling related issues.
  2. Make sure that the airflow at the front and rear of the chassis is not obstructed and that fillers are in place and correctly installed.
  3. Make sure that the room temperature is within operating specifications.
  4. Make sure that the DIMM baffles are in place.
  5. If the problem persists and there are no other DIMMs with the same indication, replace the DIMM.
- **806f0a0c-2029ffff : An Over-Temperature Condition has been detected on the [PhysicalMemoryElementName] on Subsystem [MemoryElementName].**

An over temperature condition for memory has been detected.

### Severity

Error

### Serviceable

Yes

### Automatically notify support

No

### Alert Category

Critical - Temperature

### SNMP Trap ID

0

### CIM Information

**Prefix:** PLAT ID: 0146

## User Response

Complete the following steps:

1. Check the CMM or FSM event log for any fan or cooling related issues.
  2. Make sure that the airflow at the front and rear of the chassis is not obstructed and that fillers are in place and correctly installed.
  3. Make sure that the room temperature is within operating specifications.
  4. Make sure that the DIMM baffles are in place.
  5. If the problem persists and there are no other DIMMs with the same indication, replace the DIMM.
- **806f0a0c-202affff : An Over-Temperature Condition has been detected on the [PhysicalMemoryElementName] on Subsystem [MemoryElementName].**

An over temperature condition for memory has been detected.

### Severity

Error

### Serviceable

Yes

### Automatically notify support

No

**Alert Category**

Critical - Temperature

**SNMP Trap ID**

0

**CIM Information**

**Prefix:** PLAT ID: 0146

**User Response**

Complete the following steps:

1. Check the CMM or FSM event log for any fan or cooling related issues.
  2. Make sure that the airflow at the front and rear of the chassis is not obstructed and that fillers are in place and correctly installed.
  3. Make sure that the room temperature is within operating specifications.
  4. Make sure that the DIMM baffles are in place.
  5. If the problem persists and there are no other DIMMs with the same indication, replace the DIMM.
- **806f0a0c-202bffff : An Over-Temperature Condition has been detected on the [PhysicalMemoryElementName] on Subsystem [MemoryElementName].**  
An over temperature condition for memory has been detected.

**Severity**

Error

**Serviceable**

Yes

**Automatically notify support**

No

**Alert Category**

Critical - Temperature

**SNMP Trap ID**

0

**CIM Information**

**Prefix:** PLAT ID: 0146

**User Response**

Complete the following steps:

1. Check the CMM or FSM event log for any fan or cooling related issues.
  2. Make sure that the airflow at the front and rear of the chassis is not obstructed and that fillers are in place and correctly installed.
  3. Make sure that the room temperature is within operating specifications.
  4. Make sure that the DIMM baffles are in place.
  5. If the problem persists and there are no other DIMMs with the same indication, replace the DIMM.
- **806f0a0c-202cffff : An Over-Temperature Condition has been detected on the [PhysicalMemoryElementName] on Subsystem [MemoryElementName].**  
An over temperature condition for memory has been detected.



**Severity**

Error

**Serviceable**

Yes

**Automatically notify support**

No

**Alert Category**

Critical - Temperature

**SNMP Trap ID**

0

**CIM Information****Prefix: PLAT ID:** 0146**User Response**

Complete the following steps:

1. Check the CMM or FSM event log for any fan or cooling related issues.
  2. Make sure that the airflow at the front and rear of the chassis is not obstructed and that fillers are in place and correctly installed.
  3. Make sure that the room temperature is within operating specifications.
  4. Make sure that the DIMM baffles are in place.
  5. If the problem persists and there are no other DIMMs with the same indication, replace the DIMM.
- **806f0a0c-202dffff : An Over-Temperature Condition has been detected on the [PhysicalMemoryElementName] on Subsystem [MemoryElementName].**

An over temperature condition for memory has been detected.

**Severity**

Error

**Serviceable**

Yes

**Automatically notify support**

No

**Alert Category**

Critical - Temperature

**SNMP Trap ID**

0

**CIM Information****Prefix: PLAT ID:** 0146**User Response**

Complete the following steps:

1. Check the CMM or FSM event log for any fan or cooling related issues.
2. Make sure that the airflow at the front and rear of the chassis is not obstructed and that fillers are in place and correctly installed.
3. Make sure that the room temperature is within operating specifications.

4. Make sure that the DIMM baffles are in place.
5. If the problem persists and there are no other DIMMs with the same indication, replace the DIMM.

- **806f0a0c-202effff : An Over-Temperature Condition has been detected on the [PhysicalMemoryElementName] on Subsystem [MemoryElementName].**

An over temperature condition for memory has been detected.

**Severity**

Error

**Serviceable**

Yes

**Automatically notify support**

No

**Alert Category**

Critical - Temperature

**SNMP Trap ID**

0

**CIM Information**

**Prefix: PLAT ID:** 0146

**User Response**

Complete the following steps:

1. Check the CMM or FSM event log for any fan or cooling related issues.
2. Make sure that the airflow at the front and rear of the chassis is not obstructed and that fillers are in place and correctly installed.
3. Make sure that the room temperature is within operating specifications.
4. Make sure that the DIMM baffles are in place.
5. If the problem persists and there are no other DIMMs with the same indication, replace the DIMM.

- **806f0a0c-202fffff : An Over-Temperature Condition has been detected on the [PhysicalMemoryElementName] on Subsystem [MemoryElementName].**

An over temperature condition for memory has been detected.

**Severity**

Error

**Serviceable**

Yes

**Automatically notify support**

No

**Alert Category**

Critical - Temperature

**SNMP Trap ID**

0

**CIM Information**

**Prefix: PLAT ID:** 0146

**User Response**

Complete the following steps:

1. Check the CMM or FSM event log for any fan or cooling related issues.
2. Make sure that the airflow at the front and rear of the chassis is not obstructed and that fillers are in place and correctly installed.
3. Make sure that the room temperature is within operating specifications.
4. Make sure that the DIMM baffles are in place.
5. If the problem persists and there are no other DIMMs with the same indication, replace the DIMM.

- **806f0a0c-2030ffff : An Over-Temperature Condition has been detected on the [PhysicalMemoryElementName] on Subsystem [MemoryElementName].**

An over temperature condition for memory has been detected.

**Severity**

Error

**Serviceable**

Yes

**Automatically notify support**

No

**Alert Category**

Critical - Temperature

**SNMP Trap ID**

0

**CIM Information**

**Prefix:** PLAT ID: 0146

**User Response**

Complete the following steps:

1. Check the CMM or FSM event log for any fan or cooling related issues.
2. Make sure that the airflow at the front and rear of the chassis is not obstructed and that fillers are in place and correctly installed.
3. Make sure that the room temperature is within operating specifications.
4. Make sure that the DIMM baffles are in place.
5. If the problem persists and there are no other DIMMs with the same indication, replace the DIMM.

- **806f0a13-2401ffff : A Fatal Bus Error has occurred on bus [SensorElementName].**

A fatal bus error has been detected on the System Management Bus.

**Severity**

Error

**Serviceable**

Yes

**Automatically notify support**

No

**Alert Category**

Critical - Other

**SNMP Trap ID**

**CIM Information****Prefix:** PLAT ID: 0244**User Response**

This is a UEFI detected event. The UEFI diagnostic code for this event can be found in the logged IMM message text. Please refer to the UEFI diagnostic code in the "UEFI diagnostic code" section of the Information Center for the appropriate user response.

**Related links**

– "Finding the UEFI diagnostic code" on page 776

- **806f0a13-2582ffff : A Fatal Bus Error has occurred on bus [SensorElementName].**

IMM has detected a Bus Fatal Error relating to PCI.

**Severity**

Error

**Serviceable**

Yes

**Automatically notify support**

No

**Alert Category**

Critical - Other

**SNMP Trap ID**

50

**CIM Information****Prefix:** PLAT ID: 0244**User Response**

This is a UEFI detected event. The UEFI diagnostic code for this event can be found in the logged IMM message text. Please refer to the UEFI diagnostic code in the "UEFI diagnostic code" section of the Information Center for the appropriate user response.

**Related links**

– "Finding the UEFI diagnostic code" on page 776

- **806f0b13-0701ffff : Bus [SensorElementName] is operating in a degraded state.**

IMM has detected that the DMI Bus is degraded.

**Severity**

Warning

**Serviceable**

Yes

**Automatically notify support**

No

**Alert Category**

Warning - Other

**SNMP Trap ID**

60

**CIM Information****Prefix:** PLAT ID: 0246**User Response**

Complete the following steps:

1. AC cycle the machine
2. Remove CPU 1 and inspect the CPU socket for bent pins.
3. Swap CPU 1 and CPU 2. If the error goes away, replace the original CPU 1.
4. If the problem persists, System board may need to be replaced.(Trained service personnel only)

- **81010202-0701ffff : Numeric sensor [NumericSensorElementName] going low (lower critical) has deasserted.**

A previously low voltage has returned to above its specified threshold (sensor SysBrd 12V, SysBrd 3.3V, or SysBrd 5V).

**Severity**

Info

**Serviceable**

No

**Automatically notify support**

No

**Alert Category**

Critical - Voltage

**SNMP Trap ID**

1

**CIM Information**

**Prefix: PLAT ID:** 0481

**User Response**

Information only; no action is required.

- **81010202-2801ffff : Numeric sensor [NumericSensorElementName] going low (lower critical) has deasserted.**

The previously low CMOS battery voltage has returned to above its specified threshold.

**Severity**

Info

**Serviceable**

No

**Automatically notify support**

No

**Alert Category**

Critical - Voltage

**SNMP Trap ID**

1

**CIM Information**

**Prefix: PLAT ID:** 0481

**User Response**

Information only; no action is required.

- **81010701-3701ffff : Numeric sensor [NumericSensorElementName] going high (upper non-critical) has deasserted.**

The previously high inlet 1 temperature has returned to below its specified threshold.

**Severity**

Info

**Serviceable**

No

**Automatically notify support**

No

**Alert Category**

Warning - Temperature

**SNMP Trap ID**

12

**CIM Information**

Prefix: PLAT ID: 0491

**User Response**

Information only; no action is required.

- **81010701-3702ffff : Numeric sensor [NumericSensorElementName] going high (upper non-critical) has deasserted.**

The previously high inlet 2 temperature has returned to below its specified threshold.

**Severity**

Info

**Serviceable**

No

**Automatically notify support**

No

**Alert Category**

Warning - Temperature

**SNMP Trap ID**

12

**CIM Information**

Prefix: PLAT ID: 0491

**User Response**

Information only; no action is required.

- **81010901-3701ffff : Numeric sensor [NumericSensorElementName] going high (upper critical) has deasserted.**

The previously high inlet 1 temperature has returned to below its specified threshold.

**Severity**

Info

**Serviceable**

No

**Automatically notify support**

No

**Alert Category**

Critical - Temperature

**SNMP Trap ID**

0

**CIM Information**

Prefix: PLAT ID: 0495

**User Response**

Information only; no action is required.

- **81010901-3702ffff : Numeric sensor [NumericSensorElementName] going high (upper critical) has deasserted.**

The previously high inlet 2 temperature has returned to below its specified threshold.

**Severity**

Info

**Serviceable**

No

**Automatically notify support**

No

**Alert Category**

Critical - Temperature

**SNMP Trap ID**

0

**CIM Information**

Prefix: PLAT ID: 0495

**User Response**

Information only; no action is required.

- **81010902-0701ffff : Numeric sensor [NumericSensorElementName] going high (upper critical) has deasserted.**

A previously low voltage has returned to above its specified threshold (sensor SysBrd 12V, SysBrd 3.3V, or SysBrd 5V).

**Severity**

Info

**Serviceable**

No

**Automatically notify support**

No

**Alert Category**

Critical - Voltage

**SNMP Trap ID**

1

**CIM Information**

Prefix: PLAT ID: 0495

**User Response**

Information only; no action is required.

- **81010b01-3701ffff : Numeric sensor [NumericSensorElementName] going high (upper non-recoverable) has deasserted.**

The previously high inlet temperature 1 has returned to below its specified threshold.

**Severity**

Info

**Serviceable**

No

**Automatically notify support**

No

**Alert Category**

Critical - Temperature

**SNMP Trap ID**

0

**CIM Information**

Prefix: PLAT ID: 0499

**User Response**

Information only; no action is required.

- **81010b01-3702ffff : Numeric sensor [NumericSensorElementName] going high (upper non-recoverable) has deasserted.**

The previously high inlet temperature 2 has returned to below its specified threshold.

**Severity**

Info

**Serviceable**

No

**Automatically notify support**

No

**Alert Category**

Critical - Temperature

**SNMP Trap ID**

0

**CIM Information**

Prefix: PLAT ID: 0499

**User Response**

Information only; no action is required.

- **81030006-2101ffff : Sensor Sig Verify Fail has asserted.**

Signature verification of one of the Firmware Volumes or Capsules in UEFI BIOS failed.

**Severity**

Info

**Serviceable**

No

**Automatically notify support**

No

**Alert Category**

System - Other

**SNMP Trap ID****CIM Information**

Prefix: PLAT ID: 0508

**User Response**



Automatic BIOS Recovery (ABR) should cause system to come up from UEFI image in backup bank. Reflash UEFI image in the primary bank. If error does not persist no additional recovery action is required.

- **8103000f-2101ffff : Sensor [SensorElementName] has asserted.**

IMM Firmware is corrupted.

**Severity**

Info

**Serviceable**

No

**Automatically notify support**

No

**Alert Category**

System - Other

**SNMP Trap ID**

**CIM Information**

Prefix: PLAT ID: 0508

**User Response**

Check the primary build level and update primary build to latest level.

- **8103010e-2581ffff : Sensor Memory Resized has deasserted.**

A sensor has recovered.

**Severity**

Info

**Serviceable**

No

**Automatically notify support**

No

**Alert Category**

System - Other

**SNMP Trap ID**

**CIM Information**

Prefix: PLAT ID: 0509

**User Response**

This is a UEFI detected event. The UEFI diagnostic code for this event can be found in the logged IMM message text. Please refer to the UEFI diagnostic code in the "UEFI diagnostic code" section of the Information Center for the appropriate user response.

**Related links**

– “Finding the UEFI diagnostic code” on page 776

- **81030112-0601ffff : Sensor [SensorElementName] has deasserted.**

IMM has exited a system maintenance mode (SMM Mode, SMM Monitor) where the current power state is important.

**Severity**

Info

**Serviceable**

No

**Automatically notify support**

No

**Alert Category**

System - Other

**SNMP Trap ID****CIM Information**

Prefix: PLAT ID: 0509

**User Response**

Information only; no action required.

- **81070101-030101ff : Sensor CPU 1 Overtemp has deasserted the transition from normal to non-critical state.**

The previously high microprocessor 1 temperature has returned to below its specified threshold.

**Severity**

Info

**Serviceable**

No

**Automatically notify support**

No

**Alert Category**

Warning - Temperature

**SNMP Trap ID**

12

**CIM Information**

Prefix: PLAT ID: 0521

**User Response**

Information only; no action is required.

- **81070101-030102ff : Sensor CPU 1 Overtemp has deasserted the transition from normal to non-critical state.**

The previously high microprocessor 1 temperature has returned to below its specified threshold.

**Severity**

Info

**Serviceable**

No

**Automatically notify support**

No

**Alert Category**

Warning - Temperature

**SNMP Trap ID**

12

**CIM Information**

Prefix: PLAT ID: 0521

**User Response**

Information only; no action is required.

- **81070101-0301ffff : Sensor CPU 1 Overtemp has deasserted the transition from normal to non-critical state.**

The previously high microprocessor 1 temperature has returned to below its specified threshold.

**Severity**

Info

**Serviceable**

No

**Automatically notify support**

No

**Alert Category**

Warning - Temperature

**SNMP Trap ID**

12

**CIM Information**

Prefix: PLAT ID: 0521

**User Response**

Information only; no action is required.

- **81070101-030201ff : Sensor CPU 2 Overtemp has deasserted the transition from normal to non-critical state.**

The previously high microprocessor 2 temperature has returned to below its specified threshold.

**Severity**

Info

**Serviceable**

No

**Automatically notify support**

No

**Alert Category**

Warning - Temperature

**SNMP Trap ID**

12

**CIM Information**

Prefix: PLAT ID: 0521

**User Response**

Information only; no action is required.

- **81070101-030202ff : Sensor CPU 2 Overtemp has deasserted the transition from normal to non-critical state.**

The previously high microprocessor 2 temperature has returned to below its specified threshold.

**Severity**

Info

**Serviceable**

No

**Automatically notify support**

No

**Alert Category**

Warning - Temperature

**SNMP Trap ID**

12

**CIM Information**

Prefix: PLAT ID: 0521

**User Response**

Information only; no action is required.

- **81070101-0302ffff : Sensor CPU 2 Overtemp has deasserted the transition from normal to non-critical state.**

The previously high microprocessor 2 temperature has returned to below its specified threshold.

**Severity**

Info

**Serviceable**

No

**Automatically notify support**

No

**Alert Category**

Warning - Temperature

**SNMP Trap ID**

12

**CIM Information**

Prefix: PLAT ID: 0521

**User Response**

Information only; no action is required.

- **81070101-030301ff : Sensor CPU 3 Overtemp has deasserted the transition from normal to non-critical state.**

The previously high microprocessor 3 temperature has returned to below its specified threshold.

**Severity**

Info

**Serviceable**

No

**Automatically notify support**

No

**Alert Category**

Warning - Temperature

**SNMP Trap ID**

12

**CIM Information**

Prefix: PLAT ID: 0521

**User Response**

Information only; no action is required.

- **81070101-030302ff : Sensor CPU 3 Overtemp has deasserted the transition from normal to non-critical state.**

The previously high microprocessor 3 temperature has returned to below its specified threshold.

**Severity**

Info

**Serviceable**

No

**Automatically notify support**

No

**Alert Category**

Warning - Temperature

**SNMP Trap ID**

12

**CIM Information**

**Prefix:** PLAT ID: 0521

**User Response**

Information only; no action is required.

- **81070101-0303ffff : Sensor CPU 3 Overtemp has deasserted the transition from normal to non-critical state.**

The previously high microprocessor 3 temperature has returned to below its specified threshold.

**Severity**

Info

**Serviceable**

No

**Automatically notify support**

No

**Alert Category**

Warning - Temperature

**SNMP Trap ID**

12

**CIM Information**

**Prefix:** PLAT ID: 0521

**User Response**

Information only; no action is required.

- **81070101-030401ff : Sensor CPU 4 Overtemp has deasserted the transition from normal to non-critical state.**

The previously high microprocessor 4 temperature has returned to below its specified threshold.

**Severity**

Info

**Serviceable**

No

**Automatically notify support**

No

**Alert Category**

Warning - Temperature

**SNMP Trap ID**

12

**CIM Information**

Prefix: PLAT ID: 0521

**User Response**

Information only; no action is required.

- **81070101-030402ff : Sensor CPU 4 Overtemp has deasserted the transition from normal to non-critical state.**

The previously high microprocessor 4 temperature has returned to below its specified threshold.

**Severity**

Info

**Serviceable**

No

**Automatically notify support**

No

**Alert Category**

Warning - Temperature

**SNMP Trap ID**

12

**CIM Information**

Prefix: PLAT ID: 0521

**User Response**

Information only; no action is required.

- **81070101-0304ffff : Sensor CPU 4 Overtemp has deasserted the transition from normal to non-critical state.**

The previously high microprocessor 4 temperature has returned to below its specified threshold.

**Severity**

Info

**Serviceable**

No

**Automatically notify support**

No

**Alert Category**

Warning - Temperature

**SNMP Trap ID**

12

**CIM Information**

Prefix: PLAT ID: 0521

**User Response**

Information only; no action is required.

- **81070101-2c01ffff : Sensor Mezz Exp 1 temp has deasserted the transition from normal to non-critical state.**

The previously high I/O Expansion card temperature has returned to below its specified threshold.

**Severity**

Info

**Serviceable**

No

**Automatically notify support**

No

**Alert Category**

Warning - Temperature

**SNMP Trap ID**

12

**CIM Information**

**Prefix:** PLAT ID: 0521

**User Response**

Information only; no action is required.

- **81070101-2c02ffff : Sensor Mezz Exp 2 temp has deasserted the transition from normal to non-critical state.**

The previously high I/O Expansion card temperature has returned to below its specified threshold.

**Severity**

Info

**Serviceable**

No

**Automatically notify support**

No

**Alert Category**

Warning - Temperature

**SNMP Trap ID**

12

**CIM Information**

**Prefix:** PLAT ID: 0521

**User Response**

Information only; no action is required.

- **81070101-2c03ffff : Sensor Mezz Exp 3 temp has deasserted the transition from normal to non-critical state.**

The previously high I/O Expansion card temperature has returned to below its specified threshold.

**Severity**

Info

**Serviceable**

No

**Automatically notify support**

No

**Alert Category**

Warning - Temperature

**SNMP Trap ID**

12

**CIM Information**

Prefix: PLAT ID: 0521

**User Response**

Information only; no action is required.

- **81070101-2c04ffff : Sensor Mezz Exp 4 temp has deasserted the transition from normal to non-critical state.**

The previously high I/O Expansion card temperature has returned to below its specified threshold.

**Severity**

Info

**Serviceable**

No

**Automatically notify support**

No

**Alert Category**

Warning - Temperature

**SNMP Trap ID**

12

**CIM Information**

Prefix: PLAT ID: 0521

**User Response**

Information only; no action is required.

- **81070101-2d01ffff : Sensor PCH Overtemp has deasserted the transition from normal to non-critical state.**

IMM has detected that the PCH temperature has returned to a normal range.

**Severity**

Info

**Serviceable**

No

**Automatically notify support**

No

**Alert Category**

Warning - Temperature

**SNMP Trap ID**

12

**CIM Information**

Prefix: PLAT ID: 0521

**User Response**

Information only; no action is required.

- **8107010d-0b01ffff : Sensor [SensorElementName] has deasserted the transition from normal to non-critical state.**

A drive failure causing RAID redundancy has been removed.

**Severity**



Info

**Serviceable**

No

**Automatically notify support**

No

**Alert Category**

Warning - Other

**SNMP Trap ID**

60

**CIM Information**

**Prefix:** PLAT ID: 0521

**User Response**

Information only; no action required.

- **8107010f-2201ffff : Sensor [SensorElementName] has deasserted the transition from normal to non-critical state.**

The GPT (GUID Partition Table) in the disk LUN (Logical Unit Number) has returned to normal.

**Severity**

Info

**Serviceable**

No

**Automatically notify support**

No

**Alert Category**

Warning - Other

**SNMP Trap ID**

60

**CIM Information**

**Prefix:** PLAT ID: 0521

**User Response**

Information only; no action is required. GPT Status : Sec Rollback Err : Secure Boot Err :

- **8107010f-2582ffff : Sensor [SensorElementName] has deasserted the transition from normal to non-critical state.**

The prior condition of less than optimal I/O resource configuration has been cleared.

**Severity**

Info

**Serviceable**

No

**Automatically notify support**

No

**Alert Category**

Warning - Other

**SNMP Trap ID**

60

**CIM Information**

**Prefix: PLAT ID:** 0521

**User Response**

Information only; no action is required.

- **81070114-2201ffff : Sensor TPM Lock has deasserted the transition from normal to non-critical state.**

The TPM Lock has returned to normal.

**Severity**

Info

**Serviceable**

No

**Automatically notify support**

No

**Alert Category**

Warning - Other

**SNMP Trap ID**

60

**CIM Information**

**Prefix: PLAT ID:** 0521

**User Response**

Information only; no action required.

- **81070202-0701ffff : Sensor Planar Fault has transitioned to a less severe state from critical.**

A voltage fault is no longer detected with the system board.

**Severity**

Info

**Serviceable**

No

**Automatically notify support**

No

**Alert Category**

Critical - Voltage

**SNMP Trap ID**

1

**CIM Information**

**Prefix: PLAT ID:** 0523

**User Response**

Information only; no action is required.

- **8107020d-0b01ffff : Sensor [SensorElementName] has transitioned to a less severe state from critical.**

The failed drive(s) causing a RAID redundancy loss has recovered.

**Severity**

Info

**Serviceable**

No

**Automatically notify support**

No

**Alert Category**

Critical - Other

**SNMP Trap ID**

50

**CIM Information**

**Prefix:** PLAT ID: 0523

**User Response**

Information only; no action required.

- **8107020f-2201ffff : Sensor TXT ACM Module or Drive Key Fault has transitioned to a less severe state from critical.**

TXT ACM Module or Drive Key Fault has returned to a normal state.

**Severity**

Info

**Serviceable**

No

**Automatically notify support**

No

**Alert Category**

Critical - Other

**SNMP Trap ID**

50

**CIM Information**

**Prefix:** PLAT ID: 0523

**User Response**

Information only; no action is required.

- **8107020f-2582ffff : Sensor No I/O Resources has transitioned to a less severe state from critical.**

The prior I/O resource conflict has been resolved.

**Severity**

Info

**Serviceable**

No

**Automatically notify support**

No

**Alert Category**

Critical - Other

**SNMP Trap ID**

50

**CIM Information**

**Prefix:** PLAT ID: 0523

**User Response**

Information only; no action is required.

**Related links**

– “Finding the UEFI diagnostic code” on page 776

- **81070217-2c01ffff : Sensor Mezz Exp 1 Fault has transitioned to a less severe state from critical.**

The I/O Expansion card is no longer in a fault condition.

**Severity**

Info

**Serviceable**

No

**Automatically notify support**

No

**Alert Category**

Critical - Other

**SNMP Trap ID**

50

**CIM Information**

Prefix: PLAT ID: 0523

**User Response**

Information only; no action is required.

- **81070217-2c02ffff : Sensor Mezz Exp 2 Fault has transitioned to a less severe state from critical.**

The I/O Expansion card is no longer in a fault condition.

**Severity**

Info

**Serviceable**

No

**Automatically notify support**

No

**Alert Category**

Critical - Other

**SNMP Trap ID**

50

**CIM Information**

Prefix: PLAT ID: 0523

**User Response**

Information only; no action is required.

- **81070217-2c03ffff : Sensor Mezz Exp 3 Fault has transitioned to a less severe state from critical.**

The I/O Expansion card is no longer in a fault condition.

**Severity**

Info

**Serviceable**

No

**Automatically notify support**

No

**Alert Category**

Critical - Other

**SNMP Trap ID**

50

**CIM Information****Prefix:** PLAT ID: 0523**User Response**

Information only; no action is required.

- **81070217-2c04ffff : Sensor Mezz Exp 4 Fault has transitioned to a less severe state from critical.**

The I/O Expansion card is no longer in a fault condition.

**Severity**

Info

**Serviceable**

No

**Automatically notify support**

No

**Alert Category**

Critical - Other

**SNMP Trap ID**

50

**CIM Information****Prefix:** PLAT ID: 0523**User Response**

Information only; no action is required.

- **81070219-0701ffff : Sensor Sys Board Fault has transitioned to a less severe state from critical.**

The system board critical fault has cleared.

**Severity**

Info

**Serviceable**

No

**Automatically notify support**

No

**Alert Category**

Critical - Other

**SNMP Trap ID**

50

**CIM Information****Prefix:** PLAT ID: 0523**User Response**

Information only; no action is required.

**Related links**

– “Finding the UEFI diagnostic code” on page 776

- **8107021b-0301ffff : Sensor CPU 1 QPILinkErr has transitioned to a less severe state from critical.**

IMM has detected that CPU 1 has recovered from a QPI Link Error.

**Severity**

Info

**Serviceable**

No

**Automatically notify support**

No

**Alert Category**

Critical - Other

**SNMP Trap ID**

50

**CIM Information**

**Prefix: PLAT ID:** 0523

**User Response**

Information only; no action is required.

- **8107021b-0302ffff : Sensor CPU 2 QPILinkErr has transitioned to a less severe state from critical.**  
IMM has detected that CPU 2 has recovered from a QPI Link Error.

**Severity**

Info

**Serviceable**

No

**Automatically notify support**

No

**Alert Category**

Critical - Other

**SNMP Trap ID**

50

**CIM Information**

**Prefix: PLAT ID:** 0523

**User Response**

Information only; no action is required.

- **8107021b-0303ffff : Sensor CPU 3 QPILinkErr has transitioned to a less severe state from critical.**  
IMM has detected that CPU 3 has recovered from a QPI Link Error.

**Severity**

Info

**Serviceable**

No

**Automatically notify support**

No

**Alert Category**

Critical - Other

**SNMP Trap ID**

50

**CIM Information**

**Prefix: PLAT ID:** 0523

**User Response**

Information only; no action is required.

- **8107021b-0304ffff : Sensor CPU 4 QPILinkErr has transitioned to a less severe state from critical.**

IMM has detected that CPU 4 has recovered from a QPI Link Error.

**Severity**

Info

**Serviceable**

No

**Automatically notify support**

No

**Alert Category**

Critical - Other

**SNMP Trap ID**

50

**CIM Information**

Prefix: PLAT ID: 0523

**User Response**

Information only; no action is required.

- **81070301-0301ffff : Sensor CPU 1 Overtemp has deasserted the transition to non-recoverable from a less severe state.**

The previously high microprocessor 1 temperature has returned to below its specified threshold.

**Severity**

Info

**Serviceable**

No

**Automatically notify support**

No

**Alert Category**

Critical - Temperature

**SNMP Trap ID**

0

**CIM Information**

Prefix: PLAT ID: 0525

**User Response**

Information only; no action is required.

- **81070301-0302ffff : Sensor CPU 2 Overtemp has deasserted the transition to non-recoverable from a less severe state.**

The previously high microprocessor 2 temperature has returned to below its specified threshold.

**Severity**

Info

**Serviceable**

No

**Automatically notify support**

No

**Alert Category**

Critical - Temperature

**SNMP Trap ID**

0

**CIM Information**

Prefix: PLAT ID: 0525

**User Response**

Information only; no action is required.

- **81070301-0303ffff : Sensor CPU 3 Overtemp has deasserted the transition to non-recoverable from a less severe state.**

The previously high microprocessor 3 temperature has returned to below its specified threshold.

**Severity**

Info

**Serviceable**

No

**Automatically notify support**

No

**Alert Category**

Critical - Temperature

**SNMP Trap ID**

0

**CIM Information**

Prefix: PLAT ID: 0525

**User Response**

Information only; no action is required.

- **81070301-0304ffff : Sensor CPU 4 Overtemp has deasserted the transition to non-recoverable from a less severe state.**

The previously high microprocessor 1 temperature has returned to below its specified threshold.

**Severity**

Info

**Serviceable**

No

**Automatically notify support**

No

**Alert Category**

Critical - Temperature

**SNMP Trap ID**

0

**CIM Information**

Prefix: PLAT ID: 0525

**User Response**

Information only; no action is required.

- **81070301-2c01ffff : Sensor Mezz Exp 1 temp has deasserted the transition to non-recoverable from a less severe state.**



The previously high I/O Expansion card temperature has returned below its specified threshold.

**Severity**

Info

**Serviceable**

No

**Automatically notify support**

No

**Alert Category**

Critical - Temperature

**SNMP Trap ID**

0

**CIM Information**

**Prefix: PLAT ID:** 0525

**User Response**

Information only; no action is required.

- **81070301-2c02ffff : Sensor Mezz Exp 2 temp has deasserted the transition to non-recoverable from a less severe state.**

The previously high I/O Expansion card temperature has returned below its specified threshold.

**Severity**

Info

**Serviceable**

No

**Automatically notify support**

No

**Alert Category**

Critical - Temperature

**SNMP Trap ID**

0

**CIM Information**

**Prefix: PLAT ID:** 0525

**User Response**

Information only; no action is required.

- **81070301-2c03ffff : Sensor Mezz Exp 3 temp has deasserted the transition to non-recoverable from a less severe state.**

The previously high I/O Expansion card temperature has returned below its specified threshold.

**Severity**

Info

**Serviceable**

No

**Automatically notify support**

No

**Alert Category**

Critical - Temperature

**SNMP Trap ID**

0

**CIM Information**

Prefix: PLAT ID: 0525

**User Response**

Information only; no action is required.

- **81070301-2c04ffff : Sensor Mezz Exp 4 temp has deasserted the transition to non-recoverable from a less severe state.**

The previously high I/O Expansion card temperature has returned below its specified threshold.

**Severity**

Info

**Serviceable**

No

**Automatically notify support**

No

**Alert Category**

Critical - Temperature

**SNMP Trap ID**

0

**CIM Information**

Prefix: PLAT ID: 0525

**User Response**

Information only; no action is required.

- **81070301-2d01ffff : Sensor PCH Overtemp has deasserted the transition to non-recoverable from a less severe state.**

The PCH temperature has returned to below its specified threshold.

**Severity**

Info

**Serviceable**

No

**Automatically notify support**

No

**Alert Category**

Critical - Temperature

**SNMP Trap ID**

0

**CIM Information**

Prefix: PLAT ID: 0525

**User Response**

Information only; no action is required.

- **8107030d-0b01ffff : Sensor [SensorElementName] has deasserted the transition to non-recoverable from a less severe state.**

The failed drive(s) causing RAID offline and data loss has recovered.

**Severity**

Info

**Serviceable**

No

**Automatically notify support**

No

**Alert Category**

Critical - Other

**SNMP Trap ID**

50

**CIM Information**

**Prefix: PLAT ID:** 0525

**User Response**

information only; no action required.

- **81070601-2c01ffff : Sensor Mezz Exp 1 temp has deasserted the transition to non-recoverable.**

The previously high I/O Expansion card temperature has returned below its specified threshold.

**Severity**

Info

**Serviceable**

No

**Automatically notify support**

No

**Alert Category**

Critical - Temperature

**SNMP Trap ID**

0

**CIM Information**

**Prefix: PLAT ID:** 0531

**User Response**

Information only; no action is required.

- **81070601-2c02ffff : Sensor Mezz Exp 2 temp has deasserted the transition to non-recoverable.**

The previously high I/O Expansion card temperature has returned below its specified threshold.

**Severity**

Info

**Serviceable**

No

**Automatically notify support**

No

**Alert Category**

Critical - Temperature

**SNMP Trap ID**

0

**CIM Information**

**Prefix: PLAT ID:** 0531

**User Response**

Information only; no action is required.

- **81070601-2c03ffff : Sensor Mezz Exp 3 temp has deasserted the transition to non-recoverable.**

The previously high I/O Expansion card temperature has returned below its specified threshold.

**Severity**

Info

**Serviceable**

No

**Automatically notify support**

No

**Alert Category**

Critical - Temperature

**SNMP Trap ID**

0

**CIM Information**

Prefix: PLAT ID: 0531

**User Response**

Information only; no action is required.

- **81070601-2c04ffff : Sensor Mezz Exp 4 temp has deasserted the transition to non-recoverable.**

The previously high I/O Expansion card temperature has returned below its specified threshold.

**Severity**

Info

**Serviceable**

No

**Automatically notify support**

No

**Alert Category**

Critical - Temperature

**SNMP Trap ID**

0

**CIM Information**

Prefix: PLAT ID: 0531

**User Response**

Information only; no action is required.

- **8107060f-2201ffff : Sensor BOFM Config Err has deasserted the transition to non-recoverable.**

The issue with UEFI not able to read the fabric manager configuration from the IMM has cleared.

**Severity**

Info

**Serviceable**

No

**Automatically notify support**

No

**Alert Category**

Critical - Other

**SNMP Trap ID**

50

**CIM Information**

**Prefix:** PLAT ID: 0531

**User Response**

Information only; no user action required.

- **81070617-2c01ffff : Sensor Mezz Exp 1 Fault has deasserted the transition to non-recoverable.**

The I/O expansion adapter in I/O expansion connector 1 no longer reports a non-recoverable condition.

**Severity**

Info

**Serviceable**

No

**Automatically notify support**

No

**Alert Category**

Critical - Other

**SNMP Trap ID**

50

**CIM Information**

**Prefix:** PLAT ID: 0531

**User Response**

Information only; no action is required.

- **81070617-2c02ffff : Sensor Mezz Exp 2 Fault has deasserted the transition to non-recoverable.**

The I/O expansion adapter in I/O expansion connector 2 no longer reports a non-recoverable condition.

**Severity**

Info

**Serviceable**

No

**Automatically notify support**

No

**Alert Category**

Critical - Other

**SNMP Trap ID**

50

**CIM Information**

**Prefix:** PLAT ID: 0531

**User Response**

Information only; no action is required.

- **81070617-2c03ffff : Sensor Mezz Exp 3 Fault has deasserted the transition to non-recoverable.**

The I/O expansion adapter in I/O expansion connector 3 no longer reports a non-recoverable condition.

**Severity**

Info

**Serviceable**

No

**Automatically notify support**

No

**Alert Category**

Critical - Other

**SNMP Trap ID**

50

**CIM Information**

Prefix: PLAT ID: 0531

**User Response**

Information only; no action is required.

- **81070617-2c04ffff : Sensor Mezz Exp 4 Fault has deasserted the transition to non-recoverable.**

The I/O expansion adapter in I/O expansion connector 4 no longer reports a non-recoverable condition.

**Severity**

Info

**Serviceable**

No

**Automatically notify support**

No

**Alert Category**

Critical - Other

**SNMP Trap ID**

50

**CIM Information**

Prefix: PLAT ID: 0531

**User Response**

Information only; no action is required.

- **81090112-2101ffff : Device [LogicalDeviceElementName] has been disabled.**

An account with IPMI / SNMP access has been disabled.

**Severity**

Info

**Serviceable**

No

**Automatically notify support**

No

**Alert Category**

System - Other

**SNMP Trap ID****CIM Information**

Prefix: PLAT ID: 0539

**User Response**

Information only; no action is required.

- **810b010c-2581ffff : Redundancy Lost for [RedundancySetElementName] has deasserted.**  
Redundancy has been recovered.

**Severity**

Info

**Serviceable**

No

**Automatically notify support**

No

**Alert Category**

Critical - Memory

**SNMP Trap ID**

41

**CIM Information**

Prefix: PLAT ID: 0803

**User Response**

Information only; no action is required.

**Related links**

– “Finding the UEFI diagnostic code” on page 776

- **810b030c-2581ffff : Non-redundant:Sufficient Resources from Redundancy Degraded or Fully Redundant for [RedundancySetElementName] has deasserted.**

Memory component group has regained its redundancy.

**Severity**

Info

**Serviceable**

No

**Automatically notify support**

No

**Alert Category**

Warning - Memory

**SNMP Trap ID**

43

**CIM Information**

Prefix: PLAT ID: 0807

**User Response**

Information only; no action is required.

**Related links**

– “Finding the UEFI diagnostic code” on page 776

- **810b050c-2581ffff : Non-redundant:Insufficient Resources for [RedundancySetElementName] has deasserted.**

A Redundancy Set has transitioned from Non-redundant:Insufficient Resources.

**Severity**

Info

**Serviceable**

No

**Automatically notify support**

No

**Alert Category**

Critical - Memory

**SNMP Trap ID**

41

**CIM Information**

Prefix: PLAT ID: 0811

**User Response**

Information only; no action is required.

**Related links**

– “Finding the UEFI diagnostic code” on page 776

- **816f0007-0301ffff : [ProcessorElementName] has Recovered from IERR.**

A Processor has Recovered - IERR Condition.

**Severity**

Info

**Serviceable**

No

**Automatically notify support**

No

**Alert Category**

Critical - CPU

**SNMP Trap ID**

40

**CIM Information**

Prefix: PLAT ID: 0043

**User Response**

Information only; no action is required.

**Related links**

– “Finding the UEFI diagnostic code” on page 776

- **816f0007-0302ffff : [ProcessorElementName] has Recovered from IERR.**

A Processor has Recovered - IERR Condition.

**Severity**

Info

**Serviceable**

No

**Automatically notify support**

No

**Alert Category**

Critical - CPU

**SNMP Trap ID**

40



**CIM Information**

Prefix: PLAT ID: 0043

**User Response**

Information only; no action is required.

**Related links**

– “Finding the UEFI diagnostic code” on page 776

- **816f0007-0303ffff : [ProcessorElementName] has Recovered from IERR.**

A Processor has Recovered - IERR Condition.

**Severity**

Info

**Serviceable**

No

**Automatically notify support**

No

**Alert Category**

Critical - CPU

**SNMP Trap ID**

40

**CIM Information**

Prefix: PLAT ID: 0043

**User Response**

Information only; no action is required.

**Related links**

– “Finding the UEFI diagnostic code” on page 776

- **816f0007-0304ffff : [ProcessorElementName] has Recovered from IERR.**

A Processor has Recovered - IERR Condition.

**Severity**

Info

**Serviceable**

No

**Automatically notify support**

No

**Alert Category**

Critical - CPU

**SNMP Trap ID**

40

**CIM Information**

Prefix: PLAT ID: 0043

**User Response**

Information only; no action is required.

**Related links**

– “Finding the UEFI diagnostic code” on page 776

- **816f0009-0701ffff : [PowerSupplyElementName] has been turned on.**

IMM has detected that the system power has been turned on.

**Severity**

Info

**Serviceable**

No

**Automatically notify support**

No

**Alert Category**

System - Power On

**SNMP Trap ID**

24

**CIM Information**

Prefix: PLAT ID: 0107

**User Response**

Information only; no action is required.

- **816f000d-0400ffff : The Drive [StorageVolumeElementName] has been removed from unit [PhysicalPackageElementName].**

Presence of drive 0 is no longer detected. If hard drive is absent from drive bay a filler is required.

**Severity**

Info

**Serviceable**

Yes

**Automatically notify support**

No

**Alert Category**

System - Other

**SNMP Trap ID**

22

**CIM Information**

Prefix: PLAT ID: 0163

**User Response**

- If drive was intentionally removed, no action required.
- Make sure that the drive properly seated.
- If drive is properly seated, replace the drive.

- **816f000d-0401ffff : The Drive [StorageVolumeElementName] has been removed from unit [PhysicalPackageElementName].**

Presence of drive 1 is no longer detected. If hard drive is absent from drive bay a filler is required.

**Severity**

Info

**Serviceable**

Yes

**Automatically notify support**

No

**Alert Category**

System - Other

**SNMP Trap ID**

22

**CIM Information****Prefix:** PLAT ID: 0163**User Response**

- If drive was intentionally removed, no action required.
- Make sure that the drive properly seated.
- If drive is properly seated, replace the drive.
- **816f000d-0402ffff : The Drive [StorageVolumeElementName] has been removed from unit [PhysicalPackageElementName].**

Presence of drive 2 is no longer detected. If hard drive is absent from drive bay a filler is required.

**Severity**

Info

**Serviceable**

Yes

**Automatically notify support**

No

**Alert Category**

System - Other

**SNMP Trap ID**

22

**CIM Information****Prefix:** PLAT ID: 0163**User Response**

- If drive was intentionally removed, no action required.
- Make sure that the drive properly seated.
- If drive is properly seated, replace the drive.
- **816f000d-0403ffff : The Drive [StorageVolumeElementName] has been removed from unit [PhysicalPackageElementName].**

Presence of drive 3 is no longer detected. If hard drive is absent from drive bay a filler is required.

**Severity**

Info

**Serviceable**

Yes

**Automatically notify support**

No

**Alert Category**

System - Other

**SNMP Trap ID**

22

**CIM Information****Prefix:** PLAT ID: 0163**User Response**

- If drive was intentionally removed, no action required.
- Make sure that the drive properly seated.

- If drive is properly seated, replace the drive.
- **816f000d-0404ffff : The Drive [StorageVolumeElementName] has been removed from unit [PhysicalPackageElementName].**

Presence of drive 4 is no longer detected. If hard drive is absent from drive bay a filler is required.

**Severity**

Info

**Serviceable**

Yes

**Automatically notify support**

No

**Alert Category**

System - Other

**SNMP Trap ID**

22

**CIM Information**

Prefix: PLAT ID: 0163

**User Response**

- If drive was intentionally removed, no action required.
- Make sure that the drive properly seated.
- If drive is properly seated, replace the drive.
- **816f000d-0405ffff : The Drive [StorageVolumeElementName] has been removed from unit [PhysicalPackageElementName].**

Presence of drive 5 is no longer detected. If hard drive is absent from drive bay a filler is required.

**Severity**

Info

**Serviceable**

Yes

**Automatically notify support**

No

**Alert Category**

System - Other

**SNMP Trap ID**

22

**CIM Information**

Prefix: PLAT ID: 0163

**User Response**

- If drive was intentionally removed, no action required.
- Make sure that the drive properly seated.
- If drive is properly seated, replace the drive.
- **816f000d-0406ffff : The Drive [StorageVolumeElementName] has been removed from unit [PhysicalPackageElementName].**

Presence of drive 6 is no longer detected. If hard drive is absent from drive bay a filler is required.

**Severity**

Info

**Serviceable**

Yes

**Automatically notify support**

No

**Alert Category**

System - Other

**SNMP Trap ID**

22

**CIM Information**

Prefix: PLAT ID: 0163

**User Response**

- If drive was intentionally removed, no action required.
- Make sure that the drive properly seated.
- If drive is properly seated, replace the drive.
- **816f000d-0407ffff : The Drive [StorageVolumeElementName] has been removed from unit [PhysicalPackageElementName].**

Presence of drive 7 is no longer detected. If hard drive is absent from drive bay a filler is required.

**Severity**

Info

**Serviceable**

Yes

**Automatically notify support**

No

**Alert Category**

System - Other

**SNMP Trap ID**

22

**CIM Information**

Prefix: PLAT ID: 0163

**User Response**

- If drive was intentionally removed, no action required.
- Make sure that the drive properly seated.
- If drive is properly seated, replace the drive.
- **816f000f-2201ffff : The System [ComputerSystemElementName] has detected a POST Error deassertion.**

A Post Error has recovered.

**Severity**

Info

**Serviceable**

No

**Automatically notify support**

No

**Alert Category**

Critical - Other

**SNMP Trap ID**

**CIM Information****Prefix:** PLAT ID: 0185**User Response**

This is a UEFI detected event. The UEFI diagnostic code for this event can be found in the logged IMM message text. Please refer to the UEFI diagnostic code in the "UEFI diagnostic code" section of the Information Center for the appropriate user response.

**Related links**

– "Finding the UEFI diagnostic code" on page 776

- **816f0013-1701ffff : System [ComputerSystemElementName] has recovered from a diagnostic interrupt.**

The system has recovered from a Front Panel NMI / Diagnostic Interrupt.

**Severity**

Info

**Serviceable**

No

**Automatically notify support**

No

**Alert Category**

Critical - Other

**SNMP Trap ID**

50

**CIM Information****Prefix:** PLAT ID: 0223**User Response**

Information only; no action is required.

- **816f0021-2201ffff : Fault condition removed on slot [PhysicalConnectorElementName] on system [ComputerSystemElementName].**

A fault in a slot has been removed. No Op ROM Space.

**Severity**

Info

**Serviceable**

No

**Automatically notify support**

No

**Alert Category**

Critical - Other

**SNMP Trap ID**

50

**CIM Information****Prefix:** PLAT ID: 0331**User Response**

Information only; no action is required.

**Related links**

- "Finding the UEFI diagnostic code" on page 776
- **816f0021-2582ffff : Fault condition removed on slot [PhysicalConnectorElementName] on system [ComputerSystemElementName].**

A fault in a slot has been recovered. PCIe Error.

**Severity**

Info

**Serviceable**

No

**Automatically notify support**

No

**Alert Category**

Critical - Other

**SNMP Trap ID**

50

**CIM Information**

Prefix: PLAT ID: 0331

**User Response**

This is a UEFI detected event. The UEFI diagnostic code for this event can be found in the logged IMM message text. Please refer to the UEFI diagnostic code in the "UEFI diagnostic code" section of the Information Center for the appropriate user response.

**Related links**

- "Finding the UEFI diagnostic code" on page 776
- **816f0028-2101ffff : Sensor TPM Cmd Failures has returned to normal on management system [ComputerSystemElementName].**

TPM was initialized and started successfully.

**Severity**

Info

**Serviceable**

No

**Automatically notify support**

No

**Alert Category**

Warning - Other

**SNMP Trap ID**

60

**CIM Information**

Prefix: PLAT ID: 0399

**User Response**

Information Only; no action is required.

- **816f0107-0301ffff : An Over-Temperature Condition has been removed on [ProcessorElementName].**

The microprocessor 1 temperature has returned to below the critical level.

**Severity**

Info

**Serviceable**

No

**Automatically notify support**

No

**Alert Category**

Critical - Temperature

**SNMP Trap ID**

0

**CIM Information**

Prefix: PLAT ID: 0037

**User Response**

Information only; no action is required.

- **816f0107-0302ffff : An Over-Temperature Condition has been removed on [ProcessorElementName].**

The microprocessor 2 temperature has returned to below the critical level.

**Severity**

Info

**Serviceable**

No

**Automatically notify support**

No

**Alert Category**

Critical - Temperature

**SNMP Trap ID**

0

**CIM Information**

Prefix: PLAT ID: 0037

**User Response**

Information only; no action is required.

- **816f0107-0303ffff : An Over-Temperature Condition has been removed on [ProcessorElementName].**

The microprocessor 3 temperature has returned to below the critical level.

**Severity**

Info

**Serviceable**

No

**Automatically notify support**

No

**Alert Category**

Critical - Temperature

**SNMP Trap ID**

0

**CIM Information**

Prefix: PLAT ID: 0037



**User Response**

Information only; no action is required.

- **816f0107-0304ffff : An Over-Temperature Condition has been removed on [ProcessorElementName].**

The microprocessor 4 temperature has returned to below the critical level.

**Severity**

Info

**Serviceable**

No

**Automatically notify support**

No

**Alert Category**

Critical - Temperature

**SNMP Trap ID**

0

**CIM Information**

Prefix: PLAT ID: 0037

**User Response**

Information only; no action is required.

- **816f0107-2584ffff : An Over-Temperature Condition has been removed on [ProcessorElementName].**

The previously high temperature of the specified microprocessor has returned to below its specified threshold.

**Severity**

Info

**Serviceable**

No

**Automatically notify support**

No

**Alert Category**

Critical - Temperature

**SNMP Trap ID**

0

**CIM Information**

Prefix: PLAT ID: 0037

**User Response**

Information only; no action is required.

- **816f010c-2001ffff : Uncorrectable error recovery detected for [PhysicalMemoryElementName] on Subsystem [MemoryElementName].**

A Memory uncorrectable error has recovered.

**Severity**

Info

**Serviceable**

No

**Automatically notify support**

No

**Alert Category**

Critical - Memory

**SNMP Trap ID**

41

**CIM Information**

Prefix: PLAT ID: 0139

**User Response**

Information only; no action is required.

**Related links**

– “Finding the UEFI diagnostic code” on page 776

- **816f010c-2002ffff : Uncorrectable error recovery detected for [PhysicalMemoryElementName] on Subsystem [MemoryElementName].**

A Memory uncorrectable error has recovered.

**Severity**

Info

**Serviceable**

No

**Automatically notify support**

No

**Alert Category**

Critical - Memory

**SNMP Trap ID**

41

**CIM Information**

Prefix: PLAT ID: 0139

**User Response**

Information only; no action is required.

**Related links**

– “Finding the UEFI diagnostic code” on page 776

- **816f010c-2003ffff : Uncorrectable error recovery detected for [PhysicalMemoryElementName] on Subsystem [MemoryElementName].**

A Memory uncorrectable error has recovered.

**Severity**

Info

**Serviceable**

No

**Automatically notify support**

No

**Alert Category**

Critical - Memory

**SNMP Trap ID**

41

**CIM Information**

Prefix: PLAT ID: 0139

**User Response**

Information only; no action is required.

**Related links**

- "Finding the UEFI diagnostic code" on page 776
- **816f010c-2004ffff : Uncorrectable error recovery detected for [PhysicalMemoryElementName] on Subsystem [MemoryElementName].**

A Memory uncorrectable error has recovered.

**Severity**

Info

**Serviceable**

No

**Automatically notify support**

No

**Alert Category**

Critical - Memory

**SNMP Trap ID**

41

**CIM Information**

Prefix: PLAT ID: 0139

**User Response**

Information only; no action is required.

**Related links**

- "Finding the UEFI diagnostic code" on page 776
- **816f010c-2005ffff : Uncorrectable error recovery detected for [PhysicalMemoryElementName] on Subsystem [MemoryElementName].**

A Memory uncorrectable error has recovered.

**Severity**

Info

**Serviceable**

No

**Automatically notify support**

No

**Alert Category**

Critical - Memory

**SNMP Trap ID**

41

**CIM Information**

Prefix: PLAT ID: 0139

**User Response**

Information only; no action is required.

**Related links**

- "Finding the UEFI diagnostic code" on page 776

- **816f010c-2006ffff : Uncorrectable error recovery detected for [PhysicalMemoryElementName] on Subsystem [MemoryElementName].**

A Memory uncorrectable error has recovered.

**Severity**

Info

**Serviceable**

No

**Automatically notify support**

No

**Alert Category**

Critical - Memory

**SNMP Trap ID**

41

**CIM Information**

Prefix: PLAT ID: 0139

**User Response**

Information only; no action is required.

**Related links**

– “Finding the UEFI diagnostic code” on page 776

- **816f010c-2007ffff : Uncorrectable error recovery detected for [PhysicalMemoryElementName] on Subsystem [MemoryElementName].**

A Memory uncorrectable error has recovered.

**Severity**

Info

**Serviceable**

No

**Automatically notify support**

No

**Alert Category**

Critical - Memory

**SNMP Trap ID**

41

**CIM Information**

Prefix: PLAT ID: 0139

**User Response**

Information only; no action is required.

**Related links**

– “Finding the UEFI diagnostic code” on page 776

- **816f010c-2008ffff : Uncorrectable error recovery detected for [PhysicalMemoryElementName] on Subsystem [MemoryElementName].**

A Memory uncorrectable error has recovered.

**Severity**

Info

**Serviceable**

No

**Automatically notify support**

No

**Alert Category**

Critical - Memory

**SNMP Trap ID**

41

**CIM Information**

**Prefix:** PLAT ID: 0139

**User Response**

Information only; no action is required.

**Related links**

- "Finding the UEFI diagnostic code" on page 776
- **816f010c-2009ffff : Uncorrectable error recovery detected for [PhysicalMemoryElementName] on Subsystem [MemoryElementName].**

A Memory uncorrectable error has recovered.

**Severity**

Info

**Serviceable**

No

**Automatically notify support**

No

**Alert Category**

Critical - Memory

**SNMP Trap ID**

41

**CIM Information**

**Prefix:** PLAT ID: 0139

**User Response**

Information only; no action is required.

**Related links**

- "Finding the UEFI diagnostic code" on page 776
- **816f010c-200affff : Uncorrectable error recovery detected for [PhysicalMemoryElementName] on Subsystem [MemoryElementName].**

A Memory uncorrectable error has recovered.

**Severity**

Info

**Serviceable**

No

**Automatically notify support**

No

**Alert Category**

Critical - Memory

**SNMP Trap ID**

41

**CIM Information****Prefix:** PLAT ID: 0139**User Response**

Information only; no action is required.

**Related links**

– “Finding the UEFI diagnostic code” on page 776

- **816f010c-200bffff : Uncorrectable error recovery detected for [PhysicalMemoryElementName] on Subsystem [MemoryElementName].**

A Memory uncorrectable error has recovered.

**Severity**

Info

**Serviceable**

No

**Automatically notify support**

No

**Alert Category**

Critical - Memory

**SNMP Trap ID**

41

**CIM Information****Prefix:** PLAT ID: 0139**User Response**

Information only; no action is required.

**Related links**

– “Finding the UEFI diagnostic code” on page 776

- **816f010c-200cffff : Uncorrectable error recovery detected for [PhysicalMemoryElementName] on Subsystem [MemoryElementName].**

A Memory uncorrectable error has recovered.

**Severity**

Info

**Serviceable**

No

**Automatically notify support**

No

**Alert Category**

Critical - Memory

**SNMP Trap ID**

41

**CIM Information****Prefix:** PLAT ID: 0139**User Response**

Information only; no action is required.

**Related links**

– “Finding the UEFI diagnostic code” on page 776

- **816f010c-200dfff : Uncorrectable error recovery detected for [PhysicalMemoryElementName] on Subsystem [MemoryElementName].**

A Memory uncorrectable error has recovered.

**Severity**

Info

**Serviceable**

No

**Automatically notify support**

No

**Alert Category**

Critical - Memory

**SNMP Trap ID**

41

**CIM Information**

Prefix: PLAT ID: 0139

**User Response**

Information only; no action is required.

**Related links**

– “Finding the UEFI diagnostic code” on page 776

- **816f010c-200efff : Uncorrectable error recovery detected for [PhysicalMemoryElementName] on Subsystem [MemoryElementName].**

A Memory uncorrectable error has recovered.

**Severity**

Info

**Serviceable**

No

**Automatically notify support**

No

**Alert Category**

Critical - Memory

**SNMP Trap ID**

41

**CIM Information**

Prefix: PLAT ID: 0139

**User Response**

Information only; no action is required.

**Related links**

– “Finding the UEFI diagnostic code” on page 776

- **816f010c-200ffff : Uncorrectable error recovery detected for [PhysicalMemoryElementName] on Subsystem [MemoryElementName].**

A Memory uncorrectable error has recovered.

**Severity**

Info

**Serviceable**

No

**Automatically notify support**

No

**Alert Category**

Critical - Memory

**SNMP Trap ID**

41

**CIM Information**

**Prefix: PLAT ID:** 0139

**User Response**

Information only; no action is required.

**Related links**

– “Finding the UEFI diagnostic code” on page 776

- **816f010c-2010ffff : Uncorrectable error recovery detected for [PhysicalMemoryElementName] on Subsystem [MemoryElementName].**

A Memory uncorrectable error has recovered.

**Severity**

Info

**Serviceable**

No

**Automatically notify support**

No

**Alert Category**

Critical - Memory

**SNMP Trap ID**

41

**CIM Information**

**Prefix: PLAT ID:** 0139

**User Response**

Information only; no action is required.

**Related links**

– “Finding the UEFI diagnostic code” on page 776

- **816f010c-2011ffff : Uncorrectable error recovery detected for [PhysicalMemoryElementName] on Subsystem [MemoryElementName].**

A Memory uncorrectable error has recovered.

**Severity**

Info

**Serviceable**

No

**Automatically notify support**

No

**Alert Category**



Critical - Memory

**SNMP Trap ID**

41

**CIM Information**

**Prefix:** PLAT ID: 0139

**User Response**

Information only; no action is required.

**Related links**

– “Finding the UEFI diagnostic code” on page 776

- **816f010c-2012ffff : Uncorrectable error recovery detected for [PhysicalMemoryElementName] on Subsystem [MemoryElementName].**

A Memory uncorrectable error has recovered.

**Severity**

Info

**Serviceable**

No

**Automatically notify support**

No

**Alert Category**

Critical - Memory

**SNMP Trap ID**

41

**CIM Information**

**Prefix:** PLAT ID: 0139

**User Response**

Information only; no action is required.

**Related links**

– “Finding the UEFI diagnostic code” on page 776

- **816f010c-2013ffff : Uncorrectable error recovery detected for [PhysicalMemoryElementName] on Subsystem [MemoryElementName].**

A Memory uncorrectable error has recovered.

**Severity**

Info

**Serviceable**

No

**Automatically notify support**

No

**Alert Category**

Critical - Memory

**SNMP Trap ID**

41

**CIM Information**

**Prefix:** PLAT ID: 0139

**User Response**

Information only; no action is required.

**Related links**

– “Finding the UEFI diagnostic code” on page 776

- **816f010c-2014ffff : Uncorrectable error recovery detected for [PhysicalMemoryElementName] on Subsystem [MemoryElementName].**

A Memory uncorrectable error has recovered.

**Severity**

Info

**Serviceable**

No

**Automatically notify support**

No

**Alert Category**

Critical - Memory

**SNMP Trap ID**

41

**CIM Information**

Prefix: PLAT ID: 0139

**User Response**

Information only; no action is required.

**Related links**

– “Finding the UEFI diagnostic code” on page 776

- **816f010c-2015ffff : Uncorrectable error recovery detected for [PhysicalMemoryElementName] on Subsystem [MemoryElementName].**

A Memory uncorrectable error has recovered.

**Severity**

Info

**Serviceable**

No

**Automatically notify support**

No

**Alert Category**

Critical - Memory

**SNMP Trap ID**

41

**CIM Information**

Prefix: PLAT ID: 0139

**User Response**

Information only; no action is required.

**Related links**

– “Finding the UEFI diagnostic code” on page 776

- **816f010c-2016ffff : Uncorrectable error recovery detected for [PhysicalMemoryElementName] on Subsystem [MemoryElementName].**

A Memory uncorrectable error has recovered.

**Severity**

Info

**Serviceable**

No

**Automatically notify support**

No

**Alert Category**

Critical - Memory

**SNMP Trap ID**

41

**CIM Information**

**Prefix:** PLAT ID: 0139

**User Response**

Information only; no action is required.

**Related links**

– “Finding the UEFI diagnostic code” on page 776

- **816f010c-2017ffff : Uncorrectable error recovery detected for [PhysicalMemoryElementName] on Subsystem [MemoryElementName].**

A Memory uncorrectable error has recovered.

**Severity**

Info

**Serviceable**

No

**Automatically notify support**

No

**Alert Category**

Critical - Memory

**SNMP Trap ID**

41

**CIM Information**

**Prefix:** PLAT ID: 0139

**User Response**

Information only; no action is required.

**Related links**

– “Finding the UEFI diagnostic code” on page 776

- **816f010c-2018ffff : Uncorrectable error recovery detected for [PhysicalMemoryElementName] on Subsystem [MemoryElementName].**

A Memory uncorrectable error has recovered.

**Severity**

Info

**Serviceable**

No

**Automatically notify support**

No

**Alert Category**

Critical - Memory

**SNMP Trap ID**

41

**CIM Information**

Prefix: PLAT ID: 0139

**User Response**

Information only; no action is required.

**Related links**

– “Finding the UEFI diagnostic code” on page 776

- **816f010c-2019ffff : Uncorrectable error recovery detected for [PhysicalMemoryElementName] on Subsystem [MemoryElementName].**

A Memory uncorrectable error has recovered.

**Severity**

Info

**Serviceable**

No

**Automatically notify support**

No

**Alert Category**

Critical - Memory

**SNMP Trap ID**

41

**CIM Information**

Prefix: PLAT ID: 0139

**User Response**

Information only; no action is required.

**Related links**

– “Finding the UEFI diagnostic code” on page 776

- **816f010c-201affff : Uncorrectable error recovery detected for [PhysicalMemoryElementName] on Subsystem [MemoryElementName].**

A Memory uncorrectable error has recovered.

**Severity**

Info

**Serviceable**

No

**Automatically notify support**

No

**Alert Category**

Critical - Memory

**SNMP Trap ID**

41

**CIM Information**

Prefix: PLAT ID: 0139

**User Response**

Information only; no action is required.

**Related links**

– “Finding the UEFI diagnostic code” on page 776

- **816f010c-201bffff : Uncorrectable error recovery detected for [PhysicalMemoryElementName] on Subsystem [MemoryElementName].**

A Memory uncorrectable error has recovered.

**Severity**

Info

**Serviceable**

No

**Automatically notify support**

No

**Alert Category**

Critical - Memory

**SNMP Trap ID**

41

**CIM Information**

Prefix: PLAT ID: 0139

**User Response**

Information only; no action is required.

**Related links**

– “Finding the UEFI diagnostic code” on page 776

- **816f010c-201cffff : Uncorrectable error recovery detected for [PhysicalMemoryElementName] on Subsystem [MemoryElementName].**

A Memory uncorrectable error has recovered.

**Severity**

Info

**Serviceable**

No

**Automatically notify support**

No

**Alert Category**

Critical - Memory

**SNMP Trap ID**

41

**CIM Information**

Prefix: PLAT ID: 0139

**User Response**

Information only; no action is required.

**Related links**

– “Finding the UEFI diagnostic code” on page 776

- **816f010c-201dffff : Uncorrectable error recovery detected for [PhysicalMemoryElementName] on Subsystem [MemoryElementName].**

A Memory uncorrectable error has recovered.

**Severity**

Info

**Serviceable**

No

**Automatically notify support**

No

**Alert Category**

Critical - Memory

**SNMP Trap ID**

41

**CIM Information**

**Prefix: PLAT ID:** 0139

**User Response**

Information only; no action is required.

**Related links**

– “Finding the UEFI diagnostic code” on page 776

- **816f010c-201effff : Uncorrectable error recovery detected for [PhysicalMemoryElementName] on Subsystem [MemoryElementName].**

A Memory uncorrectable error has recovered.

**Severity**

Info

**Serviceable**

No

**Automatically notify support**

No

**Alert Category**

Critical - Memory

**SNMP Trap ID**

41

**CIM Information**

**Prefix: PLAT ID:** 0139

**User Response**

Information only; no action is required.

**Related links**

– “Finding the UEFI diagnostic code” on page 776

- **816f010c-201ffff : Uncorrectable error recovery detected for [PhysicalMemoryElementName] on Subsystem [MemoryElementName].**

A Memory uncorrectable error has recovered.

**Severity**

Info

**Serviceable**

No

**Automatically notify support**

No

**Alert Category**

Critical - Memory

**SNMP Trap ID**

41

**CIM Information**

**Prefix:** PLAT ID: 0139

**User Response**

Information only; no action is required.

**Related links**

– “Finding the UEFI diagnostic code” on page 776

- **816f010c-2020ffff : Uncorrectable error recovery detected for [PhysicalMemoryElementName] on Subsystem [MemoryElementName].**

A Memory uncorrectable error has recovered.

**Severity**

Info

**Serviceable**

No

**Automatically notify support**

No

**Alert Category**

Critical - Memory

**SNMP Trap ID**

41

**CIM Information**

**Prefix:** PLAT ID: 0139

**User Response**

Information only; no action is required.

**Related links**

– “Finding the UEFI diagnostic code” on page 776

- **816f010c-2021ffff : Uncorrectable error recovery detected for [PhysicalMemoryElementName] on Subsystem [MemoryElementName].**

A Memory uncorrectable error has recovered.

**Severity**

Info

**Serviceable**

No

**Automatically notify support**

No

**Alert Category**

Critical - Memory

**SNMP Trap ID**

41

**CIM Information**

Prefix: PLAT ID: 0139

**User Response**

Information only; no action is required.

**Related links**

– “Finding the UEFI diagnostic code” on page 776

- **816f010c-2022ffff : Uncorrectable error recovery detected for [PhysicalMemoryElementName] on Subsystem [MemoryElementName].**

A Memory uncorrectable error has recovered.

**Severity**

Info

**Serviceable**

No

**Automatically notify support**

No

**Alert Category**

Critical - Memory

**SNMP Trap ID**

41

**CIM Information**

Prefix: PLAT ID: 0139

**User Response**

Information only; no action is required.

**Related links**

– “Finding the UEFI diagnostic code” on page 776

- **816f010c-2023ffff : Uncorrectable error recovery detected for [PhysicalMemoryElementName] on Subsystem [MemoryElementName].**

A Memory uncorrectable error has recovered.

**Severity**

Info

**Serviceable**

No

**Automatically notify support**

No

**Alert Category**

Critical - Memory

**SNMP Trap ID**

41

**CIM Information**

Prefix: PLAT ID: 0139

**User Response**

Information only; no action is required.

**Related links**

– “Finding the UEFI diagnostic code” on page 776



- **816f010c-2024ffff : Uncorrectable error recovery detected for [PhysicalMemoryElementName] on Subsystem [MemoryElementName].**

A Memory uncorrectable error has recovered.

**Severity**

Info

**Serviceable**

No

**Automatically notify support**

No

**Alert Category**

Critical - Memory

**SNMP Trap ID**

41

**CIM Information**

Prefix: PLAT ID: 0139

**User Response**

Information only; no action is required.

**Related links**

– “Finding the UEFI diagnostic code” on page 776

- **816f010c-2025ffff : Uncorrectable error recovery detected for [PhysicalMemoryElementName] on Subsystem [MemoryElementName].**

A Memory uncorrectable error has recovered.

**Severity**

Info

**Serviceable**

No

**Automatically notify support**

No

**Alert Category**

Critical - Memory

**SNMP Trap ID**

41

**CIM Information**

Prefix: PLAT ID: 0139

**User Response**

Information only; no action is required.

**Related links**

– “Finding the UEFI diagnostic code” on page 776

- **816f010c-2026ffff : Uncorrectable error recovery detected for [PhysicalMemoryElementName] on Subsystem [MemoryElementName].**

A Memory uncorrectable error has recovered.

**Severity**

Info

**Serviceable**

No

**Automatically notify support**

No

**Alert Category**

Critical - Memory

**SNMP Trap ID**

41

**CIM Information**

Prefix: PLAT ID: 0139

**User Response**

Information only; no action is required.

**Related links**

– “Finding the UEFI diagnostic code” on page 776

- **816f010c-2027ffff : Uncorrectable error recovery detected for [PhysicalMemoryElementName] on Subsystem [MemoryElementName].**

A Memory uncorrectable error has recovered.

**Severity**

Info

**Serviceable**

No

**Automatically notify support**

No

**Alert Category**

Critical - Memory

**SNMP Trap ID**

41

**CIM Information**

Prefix: PLAT ID: 0139

**User Response**

Information only; no action is required.

**Related links**

– “Finding the UEFI diagnostic code” on page 776

- **816f010c-2028ffff : Uncorrectable error recovery detected for [PhysicalMemoryElementName] on Subsystem [MemoryElementName].**

A Memory uncorrectable error has recovered.

**Severity**

Info

**Serviceable**

No

**Automatically notify support**

No

**Alert Category**

Critical - Memory

**SNMP Trap ID**

41

**CIM Information****Prefix:** PLAT ID: 0139**User Response**

Information only; no action is required.

**Related links**

- "Finding the UEFI diagnostic code" on page 776
- **816f010c-2029ffff : Uncorrectable error recovery detected for [PhysicalMemoryElementName] on Subsystem [MemoryElementName].**

A Memory uncorrectable error has recovered.

**Severity**

Info

**Serviceable**

No

**Automatically notify support**

No

**Alert Category**

Critical - Memory

**SNMP Trap ID**

41

**CIM Information****Prefix:** PLAT ID: 0139**User Response**

Information only; no action is required.

**Related links**

- "Finding the UEFI diagnostic code" on page 776
- **816f010c-202affff : Uncorrectable error recovery detected for [PhysicalMemoryElementName] on Subsystem [MemoryElementName].**

A Memory uncorrectable error has recovered.

**Severity**

Info

**Serviceable**

No

**Automatically notify support**

No

**Alert Category**

Critical - Memory

**SNMP Trap ID**

41

**CIM Information****Prefix:** PLAT ID: 0139**User Response**

Information only; no action is required.

**Related links**

– “Finding the UEFI diagnostic code” on page 776

- **816f010c-202bffff : Uncorrectable error recovery detected for [PhysicalMemoryElementName] on Subsystem [MemoryElementName].**

A Memory uncorrectable error has recovered.

**Severity**

Info

**Serviceable**

No

**Automatically notify support**

No

**Alert Category**

Critical - Memory

**SNMP Trap ID**

41

**CIM Information**

Prefix: PLAT ID: 0139

**User Response**

Information only; no action is required.

**Related links**

– “Finding the UEFI diagnostic code” on page 776

- **816f010c-202cffff : Uncorrectable error recovery detected for [PhysicalMemoryElementName] on Subsystem [MemoryElementName].**

A Memory uncorrectable error has recovered.

**Severity**

Info

**Serviceable**

No

**Automatically notify support**

No

**Alert Category**

Critical - Memory

**SNMP Trap ID**

41

**CIM Information**

Prefix: PLAT ID: 0139

**User Response**

Information only; no action is required.

**Related links**

– “Finding the UEFI diagnostic code” on page 776

- **816f010c-202dffff : Uncorrectable error recovery detected for [PhysicalMemoryElementName] on Subsystem [MemoryElementName].**

A Memory uncorrectable error has recovered.

**Severity**

Info

**Serviceable**

No

**Automatically notify support**

No

**Alert Category**

Critical - Memory

**SNMP Trap ID**

41

**CIM Information**

**Prefix:** PLAT ID: 0139

**User Response**

Information only; no action is required.

**Related links**

– “Finding the UEFI diagnostic code” on page 776

- **816f010c-202effff : Uncorrectable error recovery detected for [PhysicalMemoryElementName] on Subsystem [MemoryElementName].**

A Memory uncorrectable error has recovered.

**Severity**

Info

**Serviceable**

No

**Automatically notify support**

No

**Alert Category**

Critical - Memory

**SNMP Trap ID**

41

**CIM Information**

**Prefix:** PLAT ID: 0139

**User Response**

Information only; no action is required.

**Related links**

– “Finding the UEFI diagnostic code” on page 776

- **816f010c-202ffff : Uncorrectable error recovery detected for [PhysicalMemoryElementName] on Subsystem [MemoryElementName].**

A Memory uncorrectable error has recovered.

**Severity**

Info

**Serviceable**

No

**Automatically notify support**

No

**Alert Category**

Critical - Memory

**SNMP Trap ID**

41

**CIM Information**

**Prefix:** PLAT ID: 0139

**User Response**

Information only; no action is required.

**Related links**

– “Finding the UEFI diagnostic code” on page 776

- **816f010c-2030ffff : Uncorrectable error recovery detected for [PhysicalMemoryElementName] on Subsystem [MemoryElementName].**

A Memory uncorrectable error has recovered.

**Severity**

Info

**Serviceable**

No

**Automatically notify support**

No

**Alert Category**

Critical - Memory

**SNMP Trap ID**

41

**CIM Information**

**Prefix:** PLAT ID: 0139

**User Response**

Information only; no action is required.

**Related links**

– “Finding the UEFI diagnostic code” on page 776

- **816f010c-2581ffff : Uncorrectable error recovery detected for [PhysicalMemoryElementName] on Subsystem [MemoryElementName].**

A memory uncorrectable error has recovered. All DIMMs. One of the DIMMs.

**Severity**

Info

**Serviceable**

No

**Automatically notify support**

No

**Alert Category**

Critical - Memory

**SNMP Trap ID**

41

**CIM Information**

**Prefix:** PLAT ID: 0139

**User Response**

Information only; no action is required.

**Related links**

– “Finding the UEFI diagnostic code” on page 776

- **816f010d-0400ffff : The Drive [StorageVolumeElementName] has been enabled.**

The previously disabled drive 0 has been enabled.

**Severity**

Info

**Serviceable**

No

**Automatically notify support**

No

**Alert Category**

Critical - Hard Disk drive

**SNMP Trap ID**

5

**CIM Information**

**Prefix:** PLAT ID: 0167

**User Response**

Information only; no action is required.

- **816f010d-0401ffff : The Drive [StorageVolumeElementName] has been enabled.**

The previously disabled drive 1 has been enabled.

**Severity**

Info

**Serviceable**

No

**Automatically notify support**

No

**Alert Category**

Critical - Hard Disk drive

**SNMP Trap ID**

5

**CIM Information**

**Prefix:** PLAT ID: 0167

**User Response**

Information only; no action is required.

- **816f010d-0402ffff : The Drive [StorageVolumeElementName] has been enabled.**

The previously disabled drive 2 has been enabled.

**Severity**

Info

**Serviceable**

No

**Automatically notify support**

No

**Alert Category**

Critical - Hard Disk drive

**SNMP Trap ID**

5

**CIM Information**

Prefix: PLAT ID: 0167

**User Response**

Information only; no action is required.

- **816f010d-0403ffff : The Drive [StorageVolumeElementName] has been enabled.**

The previously disabled drive 3 has been enabled.

**Severity**

Info

**Serviceable**

No

**Automatically notify support**

No

**Alert Category**

Critical - Hard Disk drive

**SNMP Trap ID**

5

**CIM Information**

Prefix: PLAT ID: 0167

**User Response**

Information only; no action is required.

- **816f010d-0404ffff : The Drive [StorageVolumeElementName] has been enabled.**

The previously disabled drive 4 has been enabled.

**Severity**

Info

**Serviceable**

No

**Automatically notify support**

No

**Alert Category**

Critical - Hard Disk drive

**SNMP Trap ID**

5

**CIM Information**

Prefix: PLAT ID: 0167

**User Response**

Information only; no action is required.

- **816f010d-0405ffff : The Drive [StorageVolumeElementName] has been enabled.**

The previously disabled drive 5 has been enabled.

**Severity**



Info

**Serviceable**

No

**Automatically notify support**

No

**Alert Category**

Critical - Hard Disk drive

**SNMP Trap ID**

5

**CIM Information**

**Prefix:** PLAT ID: 0167

**User Response**

Information only; no action is required.

- **816f010d-0406ffff : The Drive [StorageVolumeElementName] has been enabled.**

The previously disabled drive 6 has been enabled.

**Severity**

Info

**Serviceable**

No

**Automatically notify support**

No

**Alert Category**

Critical - Hard Disk drive

**SNMP Trap ID**

5

**CIM Information**

**Prefix:** PLAT ID: 0167

**User Response**

Information only; no action is required.

- **816f010d-0407ffff : The Drive [StorageVolumeElementName] has been enabled.**

The previously disabled drive 7 has been enabled.

**Severity**

Info

**Serviceable**

No

**Automatically notify support**

No

**Alert Category**

Critical - Hard Disk drive

**SNMP Trap ID**

5

**CIM Information**

**Prefix:** PLAT ID: 0167

**User Response**

Information only; no action is required.

- **816f010f-2201ffff : The System [ComputerSystemElementName] has recovered from a firmware hang.**

A System Firmware hang has recovered.

**Severity**

Info

**Serviceable**

No

**Automatically notify support**

No

**Alert Category**

Critical - Other

**SNMP Trap ID**

50

**CIM Information**

Prefix: PLAT ID: 0187

**User Response**

Information only; no action is required.

**Related links**

– “Finding the UEFI diagnostic code” on page 776

- **816f0207-0301ffff : [ProcessorElementName] has Recovered from FRB1/BIST condition.**

A Processor has Recovered - FRB1/BIST condition.

**Severity**

Info

**Serviceable**

No

**Automatically notify support**

No

**Alert Category**

Critical - CPU

**SNMP Trap ID**

40

**CIM Information**

Prefix: PLAT ID: 0045

**User Response**

Information only; no action is required.

**Related links**

– “Finding the UEFI diagnostic code” on page 776

- **816f0207-0302ffff : [ProcessorElementName] has Recovered from FRB1/BIST condition.**

A Processor has Recovered - FRB1/BIST condition.

**Severity**

Info

**Serviceable**

No

**Automatically notify support**

No

**Alert Category**

Critical - CPU

**SNMP Trap ID**

40

**CIM Information**

**Prefix:** PLAT ID: 0045

**User Response**

Information only; no action is required.

**Related links**

– “Finding the UEFI diagnostic code” on page 776

- **816f0207-0303ffff : [ProcessorElementName] has Recovered from FRB1/BIST condition.**

A Processor has Recovered - FRB1/BIST condition.

**Severity**

Info

**Serviceable**

No

**Automatically notify support**

No

**Alert Category**

Critical - CPU

**SNMP Trap ID**

40

**CIM Information**

**Prefix:** PLAT ID: 0045

**User Response**

Information only; no action is required.

**Related links**

– “Finding the UEFI diagnostic code” on page 776

- **816f0207-0304ffff : [ProcessorElementName] has Recovered from FRB1/BIST condition.**

A Processor has Recovered - FRB1/BIST condition.

**Severity**

Info

**Serviceable**

No

**Automatically notify support**

No

**Alert Category**

Critical - CPU

**SNMP Trap ID**

40

**CIM Information**

Prefix: PLAT ID: 0045

**User Response**

Information only; no action is required.

**Related links**

– “Finding the UEFI diagnostic code” on page 776

- **816f0207-2584ffff : [ProcessorElementName] has Recovered from FRB1/BIST condition.**

A processor recovered - FRB1/BIST condition. All CPUs. One of CPUs.

**Severity**

Info

**Serviceable**

No

**Automatically notify support**

No

**Alert Category**

Critical - CPU

**SNMP Trap ID**

40

**CIM Information**

Prefix: PLAT ID: 0045

**User Response**

Information only; no action is required.

**Related links**

– “Finding the UEFI diagnostic code” on page 776

- **816f020d-0400ffff : Failure no longer Predicted on drive [StorageVolumeElementName] for array [ComputerSystemElementName].**

The predicted failure for Drive 0 no longer exists.

**Severity**

Info

**Serviceable**

No

**Automatically notify support**

No

**Alert Category**

System - Predicted Failure

**SNMP Trap ID**

27

**CIM Information**

Prefix: PLAT ID: 0169

**User Response**

Information only; no action is required.

- **816f020d-0401ffff : Failure no longer Predicted on drive [StorageVolumeElementName] for array [ComputerSystemElementName].**

The predicted failure for Drive 1 no longer exists.

**Severity**

Info

**Serviceable**

No

**Automatically notify support**

No

**Alert Category**

System - Predicted Failure

**SNMP Trap ID**

27

**CIM Information**

Prefix: PLAT ID: 0169

**User Response**

Information only; no action is required.

- **816f020d-0402ffff : Failure no longer Predicted on drive [StorageVolumeElementName] for array [ComputerSystemElementName].**

The predicted failure for Drive 2 no longer exists.

**Severity**

Info

**Serviceable**

No

**Automatically notify support**

No

**Alert Category**

System - Predicted Failure

**SNMP Trap ID**

27

**CIM Information**

Prefix: PLAT ID: 0169

**User Response**

Information only; no action is required.

- **816f020d-0403ffff : Failure no longer Predicted on drive [StorageVolumeElementName] for array [ComputerSystemElementName].**

The predicted failure for Drive 3 no longer exists.

**Severity**

Info

**Serviceable**

No

**Automatically notify support**

No

**Alert Category**

System - Predicted Failure

**SNMP Trap ID**

27

**CIM Information**

Prefix: PLAT ID: 0169

**User Response**

Information only; no action is required.

- **816f020d-0404ffff : Failure no longer Predicted on drive [StorageVolumeElementName] for array [ComputerSystemElementName].**

The predicted failure for Drive 4 no longer exists.

**Severity**

Info

**Serviceable**

No

**Automatically notify support**

No

**Alert Category**

System - Predicted Failure

**SNMP Trap ID**

27

**CIM Information**

Prefix: PLAT ID: 0169

**User Response**

Information only; no action is required.

- **816f020d-0405ffff : Failure no longer Predicted on drive [StorageVolumeElementName] for array [ComputerSystemElementName].**

The predicted failure for Drive 5 no longer exists.

**Severity**

Info

**Serviceable**

No

**Automatically notify support**

No

**Alert Category**

System - Predicted Failure

**SNMP Trap ID**

27

**CIM Information**

Prefix: PLAT ID: 0169

**User Response**

Information only; no action is required.

- **816f020d-0406ffff : Failure no longer Predicted on drive [StorageVolumeElementName] for array [ComputerSystemElementName].**

The predicted failure for Drive 6 no longer exists.

**Severity**

Info

**Serviceable**

No

**Automatically notify support**

No

**Alert Category**

System - Predicted Failure

**SNMP Trap ID**

27

**CIM Information**

**Prefix:** PLAT ID: 0169

**User Response**

Information only; no action is required.

- **816f020d-0407ffff : Failure no longer Predicted on drive [StorageVolumeElementName] for array [ComputerSystemElementName].**

The predicted failure for Drive 7 no longer exists.

**Severity**

Info

**Serviceable**

No

**Automatically notify support**

No

**Alert Category**

System - Predicted Failure

**SNMP Trap ID**

27

**CIM Information**

**Prefix:** PLAT ID: 0169

**User Response**

Information only; no action is required.

- **816f0225-1f05ffff : LOM1 has been enabled.**

The LAN On Motherboard (LOM) 1 is enabled.

**Severity**

Info

**Serviceable**

No

**Automatically notify support**

No

**Alert Category**

System - Other

**SNMP Trap ID**

**CIM Information**

**Prefix:** PLAT ID: 0395

**User Response**

Information only; no action is required.

- **816f0225-1f06ffff : LOM2 has been enabled.**

The LAN On Motherboard (LOM) 2 is enabled.

**Severity**

Info

**Serviceable**

No

**Automatically notify support**

No

**Alert Category**

System - Other

**SNMP Trap ID**

**CIM Information**

Prefix: PLAT ID: 0395

**User Response**

Information only; no action is required.

- **816f030c-2001ffff : Scrub Failure for [PhysicalMemoryElementName] on Subsystem [MemoryElementName] has recovered.**

A Memory Scrub failure detected during boot has recovered.

**Severity**

Info

**Serviceable**

No

**Automatically notify support**

No

**Alert Category**

Critical - Memory

**SNMP Trap ID**

41

**CIM Information**

Prefix: PLAT ID: 0137

**User Response**

Information only; no action is required.

- **816f030c-2002ffff : Scrub Failure for [PhysicalMemoryElementName] on Subsystem [MemoryElementName] has recovered.**

A Memory Scrub failure detected during boot has recovered.

**Severity**

Info

**Serviceable**

No

**Automatically notify support**

No

**Alert Category**



Critical - Memory

**SNMP Trap ID**

41

**CIM Information**

**Prefix:** PLAT ID: 0137

**User Response**

Information only; no action is required.

- **816f030c-2003ffff : Scrub Failure for [PhysicalMemoryElementName] on Subsystem [MemoryElementName] has recovered.**

A Memory Scrub failure detected during boot has recovered.

**Severity**

Info

**Serviceable**

No

**Automatically notify support**

No

**Alert Category**

Critical - Memory

**SNMP Trap ID**

41

**CIM Information**

**Prefix:** PLAT ID: 0137

**User Response**

Information only; no action is required.

- **816f030c-2004ffff : Scrub Failure for [PhysicalMemoryElementName] on Subsystem [MemoryElementName] has recovered.**

A Memory Scrub failure detected during boot has recovered.

**Severity**

Info

**Serviceable**

No

**Automatically notify support**

No

**Alert Category**

Critical - Memory

**SNMP Trap ID**

41

**CIM Information**

**Prefix:** PLAT ID: 0137

**User Response**

Information only; no action is required.

- **816f030c-2005ffff : Scrub Failure for [PhysicalMemoryElementName] on Subsystem [MemoryElementName] has recovered.**

A Memory Scrub failure detected during boot has recovered.

**Severity**

Info

**Serviceable**

No

**Automatically notify support**

No

**Alert Category**

Critical - Memory

**SNMP Trap ID**

41

**CIM Information****Prefix: PLAT ID:** 0137**User Response**

Information only; no action is required.

- **816f030c-2006ffff : Scrub Failure for [PhysicalMemoryElementName] on Subsystem [MemoryElementName] has recovered.**

A Memory Scrub failure detected during boot has recovered.

**Severity**

Info

**Serviceable**

No

**Automatically notify support**

No

**Alert Category**

Critical - Memory

**SNMP Trap ID**

41

**CIM Information****Prefix: PLAT ID:** 0137**User Response**

Information only; no action is required.

- **816f030c-2007ffff : Scrub Failure for [PhysicalMemoryElementName] on Subsystem [MemoryElementName] has recovered.**

A Memory Scrub failure detected during boot has recovered.

**Severity**

Info

**Serviceable**

No

**Automatically notify support**

No

**Alert Category**

Critical - Memory

**SNMP Trap ID**

41

**CIM Information**

Prefix: PLAT ID: 0137

**User Response**

Information only; no action is required.

- **816f030c-2008ffff : Scrub Failure for [PhysicalMemoryElementName] on Subsystem [MemoryElementName] has recovered.**

A Memory Scrub failure detected during boot has recovered.

**Severity**

Info

**Serviceable**

No

**Automatically notify support**

No

**Alert Category**

Critical - Memory

**SNMP Trap ID**

41

**CIM Information**

Prefix: PLAT ID: 0137

**User Response**

Information only; no action is required.

- **816f030c-2009ffff : Scrub Failure for [PhysicalMemoryElementName] on Subsystem [MemoryElementName] has recovered.**

A Memory Scrub failure detected during boot has recovered.

**Severity**

Info

**Serviceable**

No

**Automatically notify support**

No

**Alert Category**

Critical - Memory

**SNMP Trap ID**

41

**CIM Information**

Prefix: PLAT ID: 0137

**User Response**

Information only; no action is required.

- **816f030c-200affff : Scrub Failure for [PhysicalMemoryElementName] on Subsystem [MemoryElementName] has recovered.**

A Memory Scrub failure detected during boot has recovered.

**Severity**

Info

**Serviceable**

No

**Automatically notify support**

No

**Alert Category**

Critical - Memory

**SNMP Trap ID**

41

**CIM Information**

Prefix: PLAT ID: 0137

**User Response**

Information only; no action is required.

- **816f030c-200bffff : Scrub Failure for [PhysicalMemoryElementName] on Subsystem [MemoryElementName] has recovered.**

A Memory Scrub failure detected during boot has recovered.

**Severity**

Info

**Serviceable**

No

**Automatically notify support**

No

**Alert Category**

Critical - Memory

**SNMP Trap ID**

41

**CIM Information**

Prefix: PLAT ID: 0137

**User Response**

Information only; no action is required.

- **816f030c-200cffff : Scrub Failure for [PhysicalMemoryElementName] on Subsystem [MemoryElementName] has recovered.**

A Memory Scrub failure detected during boot has recovered.

**Severity**

Info

**Serviceable**

No

**Automatically notify support**

No

**Alert Category**

Critical - Memory

**SNMP Trap ID**

41

**CIM Information**

Prefix: PLAT ID: 0137

**User Response**

Information only; no action is required.

- **816f030c-200dfff : Scrub Failure for [PhysicalMemoryElementName] on Subsystem [MemoryElementName] has recovered.**

A Memory Scrub failure detected during boot has recovered.

**Severity**

Info

**Serviceable**

No

**Automatically notify support**

No

**Alert Category**

Critical - Memory

**SNMP Trap ID**

41

**CIM Information**

**Prefix: PLAT ID: 0137**

**User Response**

Information only; no action is required.

- **816f030c-200efff : Scrub Failure for [PhysicalMemoryElementName] on Subsystem [MemoryElementName] has recovered.**

A Memory Scrub failure detected during boot has recovered.

**Severity**

Info

**Serviceable**

No

**Automatically notify support**

No

**Alert Category**

Critical - Memory

**SNMP Trap ID**

41

**CIM Information**

**Prefix: PLAT ID: 0137**

**User Response**

Information only; no action is required.

- **816f030c-200ffff : Scrub Failure for [PhysicalMemoryElementName] on Subsystem [MemoryElementName] has recovered.**

A Memory Scrub failure detected during boot has recovered.

**Severity**

Info

**Serviceable**

No

**Automatically notify support**

No

**Alert Category**

Critical - Memory

**SNMP Trap ID**

41

**CIM Information**

Prefix: PLAT ID: 0137

**User Response**

Information only; no action is required.

- **816f030c-2010ffff : Scrub Failure for [PhysicalMemoryElementName] on Subsystem [MemoryElementName] has recovered.**

A Memory Scrub failure detected during boot has recovered.

**Severity**

Info

**Serviceable**

No

**Automatically notify support**

No

**Alert Category**

Critical - Memory

**SNMP Trap ID**

41

**CIM Information**

Prefix: PLAT ID: 0137

**User Response**

Information only; no action is required.

- **816f030c-2011ffff : Scrub Failure for [PhysicalMemoryElementName] on Subsystem [MemoryElementName] has recovered.**

A Memory Scrub failure detected during boot has recovered.

**Severity**

Info

**Serviceable**

No

**Automatically notify support**

No

**Alert Category**

Critical - Memory

**SNMP Trap ID**

41

**CIM Information**

Prefix: PLAT ID: 0137

**User Response**

Information only; no action is required.

- **816f030c-2012ffff : Scrub Failure for [PhysicalMemoryElementName] on Subsystem [MemoryElementName] has recovered.**

A Memory Scrub failure detected during boot has recovered.

**Severity**

Info

**Serviceable**

No

**Automatically notify support**

No

**Alert Category**

Critical - Memory

**SNMP Trap ID**

41

**CIM Information**

Prefix: PLAT ID: 0137

**User Response**

Information only; no action is required.

- **816f030c-2013ffff : Scrub Failure for [PhysicalMemoryElementName] on Subsystem [MemoryElementName] has recovered.**

A Memory Scrub failure detected during boot has recovered.

**Severity**

Info

**Serviceable**

No

**Automatically notify support**

No

**Alert Category**

Critical - Memory

**SNMP Trap ID**

41

**CIM Information**

Prefix: PLAT ID: 0137

**User Response**

Information only; no action is required.

- **816f030c-2014ffff : Scrub Failure for [PhysicalMemoryElementName] on Subsystem [MemoryElementName] has recovered.**

A Memory Scrub failure detected during boot has recovered.

**Severity**

Info

**Serviceable**

No

**Automatically notify support**

No

**Alert Category**

Critical - Memory

**SNMP Trap ID**

41

**CIM Information**

Prefix: PLAT ID: 0137

**User Response**

Information only; no action is required.

- **816f030c-2015ffff : Scrub Failure for [PhysicalMemoryElementName] on Subsystem [MemoryElementName] has recovered.**

A Memory Scrub failure detected during boot has recovered.

**Severity**

Info

**Serviceable**

No

**Automatically notify support**

No

**Alert Category**

Critical - Memory

**SNMP Trap ID**

41

**CIM Information**

Prefix: PLAT ID: 0137

**User Response**

Information only; no action is required.

- **816f030c-2016ffff : Scrub Failure for [PhysicalMemoryElementName] on Subsystem [MemoryElementName] has recovered.**

A Memory Scrub failure detected during boot has recovered.

**Severity**

Info

**Serviceable**

No

**Automatically notify support**

No

**Alert Category**

Critical - Memory

**SNMP Trap ID**

41

**CIM Information**

Prefix: PLAT ID: 0137

**User Response**

Information only; no action is required.

- **816f030c-2017ffff : Scrub Failure for [PhysicalMemoryElementName] on Subsystem [MemoryElementName] has recovered.**

A Memory Scrub failure detected during boot has recovered.

**Severity**



Info

**Serviceable**

No

**Automatically notify support**

No

**Alert Category**

Critical - Memory

**SNMP Trap ID**

41

**CIM Information**

**Prefix:** PLAT ID: 0137

**User Response**

Information only; no action is required.

- **816f030c-2018ffff : Scrub Failure for [PhysicalMemoryElementName] on Subsystem [MemoryElementName] has recovered.**

A Memory Scrub failure detected during boot has recovered.

**Severity**

Info

**Serviceable**

No

**Automatically notify support**

No

**Alert Category**

Critical - Memory

**SNMP Trap ID**

41

**CIM Information**

**Prefix:** PLAT ID: 0137

**User Response**

Information only; no action is required.

- **816f030c-2019ffff : Scrub Failure for [PhysicalMemoryElementName] on Subsystem [MemoryElementName] has recovered.**

A Memory Scrub failure detected during boot has recovered.

**Severity**

Info

**Serviceable**

No

**Automatically notify support**

No

**Alert Category**

Critical - Memory

**SNMP Trap ID**

41

**CIM Information**

**Prefix: PLAT ID: 0137**

**User Response**

Information only; no action is required.

- **816f030c-201affff : Scrub Failure for [PhysicalMemoryElementName] on Subsystem [MemoryElementName] has recovered.**

A Memory Scrub failure detected during boot has recovered.

**Severity**

Info

**Serviceable**

No

**Automatically notify support**

No

**Alert Category**

Critical - Memory

**SNMP Trap ID**

41

**CIM Information**

**Prefix: PLAT ID: 0137**

**User Response**

Information only; no action is required.

- **816f030c-201bffff : Scrub Failure for [PhysicalMemoryElementName] on Subsystem [MemoryElementName] has recovered.**

A Memory Scrub failure detected during boot has recovered.

**Severity**

Info

**Serviceable**

No

**Automatically notify support**

No

**Alert Category**

Critical - Memory

**SNMP Trap ID**

41

**CIM Information**

**Prefix: PLAT ID: 0137**

**User Response**

Information only; no action is required.

- **816f030c-201cffff : Scrub Failure for [PhysicalMemoryElementName] on Subsystem [MemoryElementName] has recovered.**

A Memory Scrub failure detected during boot has recovered.

**Severity**

Info

**Serviceable**

No

**Automatically notify support**

No

**Alert Category**

Critical - Memory

**SNMP Trap ID**

41

**CIM Information**

Prefix: PLAT ID: 0137

**User Response**

Information only; no action is required.

- **816f030c-201dfff : Scrub Failure for [PhysicalMemoryElementName] on Subsystem [MemoryElementName] has recovered.**

A Memory Scrub failure detected during boot has recovered.

**Severity**

Info

**Serviceable**

No

**Automatically notify support**

No

**Alert Category**

Critical - Memory

**SNMP Trap ID**

41

**CIM Information**

Prefix: PLAT ID: 0137

**User Response**

Information only; no action is required.

- **816f030c-201efff : Scrub Failure for [PhysicalMemoryElementName] on Subsystem [MemoryElementName] has recovered.**

A Memory Scrub failure detected during boot has recovered.

**Severity**

Info

**Serviceable**

No

**Automatically notify support**

No

**Alert Category**

Critical - Memory

**SNMP Trap ID**

41

**CIM Information**

Prefix: PLAT ID: 0137

**User Response**

Information only; no action is required.

- **816f030c-201ffff : Scrub Failure for [PhysicalMemoryElementName] on Subsystem [MemoryElementName] has recovered.**

A Memory Scrub failure detected during boot has recovered.

**Severity**

Info

**Serviceable**

No

**Automatically notify support**

No

**Alert Category**

Critical - Memory

**SNMP Trap ID**

41

**CIM Information**

Prefix: PLAT ID: 0137

**User Response**

Information only; no action is required.

- **816f030c-2020fff : Scrub Failure for [PhysicalMemoryElementName] on Subsystem [MemoryElementName] has recovered.**

A Memory Scrub failure detected during boot has recovered.

**Severity**

Info

**Serviceable**

No

**Automatically notify support**

No

**Alert Category**

Critical - Memory

**SNMP Trap ID**

41

**CIM Information**

Prefix: PLAT ID: 0137

**User Response**

Information only; no action is required.

- **816f030c-2021fff : Scrub Failure for [PhysicalMemoryElementName] on Subsystem [MemoryElementName] has recovered.**

A Memory Scrub failure detected during boot has recovered.

**Severity**

Info

**Serviceable**

No

**Automatically notify support**

No

**Alert Category**

Critical - Memory

**SNMP Trap ID**

41

**CIM Information**

**Prefix:** PLAT ID: 0137

**User Response**

Information only; no action is required.

- **816f030c-2022ffff : Scrub Failure for [PhysicalMemoryElementName] on Subsystem [MemoryElementName] has recovered.**

A Memory Scrub failure detected during boot has recovered.

**Severity**

Info

**Serviceable**

No

**Automatically notify support**

No

**Alert Category**

Critical - Memory

**SNMP Trap ID**

41

**CIM Information**

**Prefix:** PLAT ID: 0137

**User Response**

Information only; no action is required.

- **816f030c-2023ffff : Scrub Failure for [PhysicalMemoryElementName] on Subsystem [MemoryElementName] has recovered.**

A Memory Scrub failure detected during boot has recovered.

**Severity**

Info

**Serviceable**

No

**Automatically notify support**

No

**Alert Category**

Critical - Memory

**SNMP Trap ID**

41

**CIM Information**

**Prefix:** PLAT ID: 0137

**User Response**

Information only; no action is required.

- **816f030c-2024ffff : Scrub Failure for [PhysicalMemoryElementName] on Subsystem [MemoryElementName] has recovered.**

A Memory Scrub failure detected during boot has recovered.

**Severity**

Info

**Serviceable**

No

**Automatically notify support**

No

**Alert Category**

Critical - Memory

**SNMP Trap ID**

41

**CIM Information**

Prefix: PLAT ID: 0137

**User Response**

Information only; no action is required.

- **816f030c-2025ffff : Scrub Failure for [PhysicalMemoryElementName] on Subsystem [MemoryElementName] has recovered.**

A Memory Scrub failure detected during boot has recovered.

**Severity**

Info

**Serviceable**

No

**Automatically notify support**

No

**Alert Category**

Critical - Memory

**SNMP Trap ID**

41

**CIM Information**

Prefix: PLAT ID: 0137

**User Response**

Information only; no action is required.

- **816f030c-2026ffff : Scrub Failure for [PhysicalMemoryElementName] on Subsystem [MemoryElementName] has recovered.**

A Memory Scrub failure detected during boot has recovered.

**Severity**

Info

**Serviceable**

No

**Automatically notify support**

No

**Alert Category**

Critical - Memory

**SNMP Trap ID**

41

**CIM Information**

Prefix: PLAT ID: 0137

**User Response**

Information only; no action is required.

- **816f030c-2027ffff : Scrub Failure for [PhysicalMemoryElementName] on Subsystem [MemoryElementName] has recovered.**

A Memory Scrub failure detected during boot has recovered.

**Severity**

Info

**Serviceable**

No

**Automatically notify support**

No

**Alert Category**

Critical - Memory

**SNMP Trap ID**

41

**CIM Information**

Prefix: PLAT ID: 0137

**User Response**

Information only; no action is required.

- **816f030c-2028ffff : Scrub Failure for [PhysicalMemoryElementName] on Subsystem [MemoryElementName] has recovered.**

A Memory Scrub failure detected during boot has recovered.

**Severity**

Info

**Serviceable**

No

**Automatically notify support**

No

**Alert Category**

Critical - Memory

**SNMP Trap ID**

41

**CIM Information**

Prefix: PLAT ID: 0137

**User Response**

Information only; no action is required.

- **816f030c-2029ffff : Scrub Failure for [PhysicalMemoryElementName] on Subsystem [MemoryElementName] has recovered.**

A Memory Scrub failure detected during boot has recovered.

**Severity**

Info

**Serviceable**

No

**Automatically notify support**

No

**Alert Category**

Critical - Memory

**SNMP Trap ID**

41

**CIM Information**

Prefix: PLAT ID: 0137

**User Response**

Information only; no action is required.

- **816f030c-202affff : Scrub Failure for [PhysicalMemoryElementName] on Subsystem [MemoryElementName] has recovered.**

A Memory Scrub failure detected during boot has recovered.

**Severity**

Info

**Serviceable**

No

**Automatically notify support**

No

**Alert Category**

Critical - Memory

**SNMP Trap ID**

41

**CIM Information**

Prefix: PLAT ID: 0137

**User Response**

Information only; no action is required.

- **816f030c-202bffff : Scrub Failure for [PhysicalMemoryElementName] on Subsystem [MemoryElementName] has recovered.**

A Memory Scrub failure detected during boot has recovered.

**Severity**

Info

**Serviceable**

No

**Automatically notify support**

No

**Alert Category**

Critical - Memory

**SNMP Trap ID**

41

**CIM Information**



**Prefix:** PLAT ID: 0137

**User Response**

Information only; no action is required.

- **816f030c-202cffff : Scrub Failure for [PhysicalMemoryElementName] on Subsystem [MemoryElementName] has recovered.**

A Memory Scrub failure detected during boot has recovered.

**Severity**

Info

**Serviceable**

No

**Automatically notify support**

No

**Alert Category**

Critical - Memory

**SNMP Trap ID**

41

**CIM Information**

**Prefix:** PLAT ID: 0137

**User Response**

Information only; no action is required.

- **816f030c-202dffff : Scrub Failure for [PhysicalMemoryElementName] on Subsystem [MemoryElementName] has recovered.**

A Memory Scrub failure detected during boot has recovered.

**Severity**

Info

**Serviceable**

No

**Automatically notify support**

No

**Alert Category**

Critical - Memory

**SNMP Trap ID**

41

**CIM Information**

**Prefix:** PLAT ID: 0137

**User Response**

Information only; no action is required.

- **816f030c-202effff : Scrub Failure for [PhysicalMemoryElementName] on Subsystem [MemoryElementName] has recovered.**

A Memory Scrub failure detected during boot has recovered.

**Severity**

Info

**Serviceable**

No

**Automatically notify support**

No

**Alert Category**

Critical - Memory

**SNMP Trap ID**

41

**CIM Information**

Prefix: PLAT ID: 0137

**User Response**

Information only; no action is required.

- **816f030c-202ffff : Scrub Failure for [PhysicalMemoryElementName] on Subsystem [MemoryElementName] has recovered.**

A Memory Scrub failure detected during boot has recovered.

**Severity**

Info

**Serviceable**

No

**Automatically notify support**

No

**Alert Category**

Critical - Memory

**SNMP Trap ID**

41

**CIM Information**

Prefix: PLAT ID: 0137

**User Response**

Information only; no action is required.

- **816f030c-2030fff : Scrub Failure for [PhysicalMemoryElementName] on Subsystem [MemoryElementName] has recovered.**

A Memory Scrub failure detected during boot has recovered.

**Severity**

Info

**Serviceable**

No

**Automatically notify support**

No

**Alert Category**

Critical - Memory

**SNMP Trap ID**

41

**CIM Information**

Prefix: PLAT ID: 0137

**User Response**

Information only; no action is required.

- **816f030c-2581ffff : Scrub Failure for [PhysicalMemoryElementName] on Subsystem [MemoryElementName] has recovered.**

A Memory Scrub failure detected during boot has recovered on All DIMMs or One of the DIMMs.

**Severity**

Info

**Serviceable**

No

**Automatically notify support**

No

**Alert Category**

Critical - Memory

**SNMP Trap ID**

41

**CIM Information**

Prefix: PLAT ID: 0137

**User Response**

Information only; no action is required.

- **816f030d-0400ffff : Hot spare disabled for [ComputerSystemElementName].**

A hot spare is not available.

**Severity**

Info

**Serviceable**

No

**Automatically notify support**

No

**Alert Category**

System - Other

**SNMP Trap ID**

**CIM Information**

Prefix: PLAT ID: 0171

**User Response**

Information only; no action required.

- **816f030d-0401ffff : Hot spare disabled for [ComputerSystemElementName].**

A hot spare is not available.

**Severity**

Info

**Serviceable**

No

**Automatically notify support**

No

**Alert Category**

System - Other

## SNMP Trap ID

### CIM Information

Prefix: PLAT ID: 0171

### User Response

Information only; no action required.

- **816f030d-0402ffff : Hot spare disabled for [ComputerSystemElementName].**

A hot spare is not available.

### Severity

Info

### Serviceable

No

### Automatically notify support

No

### Alert Category

System - Other

## SNMP Trap ID

11/24/2014

### CIM Information

Prefix: PLAT ID: 0171

### User Response

Information only; no action required.

- **816f030d-0403ffff : Hot spare disabled for [ComputerSystemElementName].**

A hot spare is not available.

### Severity

Info

### Serviceable

No

### Automatically notify support

No

### Alert Category

System - Other

## SNMP Trap ID

### CIM Information

Prefix: PLAT ID: 0171

### User Response

Information only; no action required.

- **816f030d-0404ffff : Hot spare disabled for [ComputerSystemElementName].**

A hot spare is not available.

### Severity

Info

### Serviceable

No

**Automatically notify support**

No

**Alert Category**

System - Other

**SNMP Trap ID**

**CIM Information**

Prefix: PLAT ID: 0171

**User Response**

Information only; no action required.

- **816f030d-0405ffff : Hot spare disabled for [ComputerSystemElementName].**

A hot spare is not available.

**Severity**

Info

**Serviceable**

No

**Automatically notify support**

No

**Alert Category**

System - Other

**SNMP Trap ID**

**CIM Information**

Prefix: PLAT ID: 0171

**User Response**

Information only; no action required.

- **816f030d-0406ffff : Hot spare disabled for [ComputerSystemElementName].**

A hot spare is not available.

**Severity**

Info

**Serviceable**

No

**Automatically notify support**

No

**Alert Category**

System - Other

**SNMP Trap ID**

**CIM Information**

Prefix: PLAT ID: 0171

**User Response**

Information only; no action required.

- **816f030d-0407ffff : Hot spare disabled for [ComputerSystemElementName].**

A hot spare is not available.

**Severity**

Info

**Serviceable**

No

**Automatically notify support**

No

**Alert Category**

System - Other

**SNMP Trap ID**

**CIM Information**

Prefix: PLAT ID: 0171

**User Response**

Information only; no action required.

- **816f0313-1701ffff : System [ComputerSystemElementName] has recovered from an NMI.**

A Software NMI has Recovered.

**Severity**

Info

**Serviceable**

No

**Automatically notify support**

No

**Alert Category**

Critical - Other

**SNMP Trap ID**

50

**CIM Information**

Prefix: PLAT ID: 0230

**User Response**

Information only; no action is required.

- **816f040c-2001ffff : [PhysicalMemoryElementName] Enabled on Subsystem [MemoryElementName].**

Memory has been enabled.

**Severity**

Info

**Serviceable**

No

**Automatically notify support**

No

**Alert Category**

System - Other

**SNMP Trap ID**

**CIM Information**

Prefix: PLAT ID: 0130

**User Response**

Information only; no action is required.

**Related links**

– “Finding the UEFI diagnostic code” on page 776

- **816f040c-2002ffff : [PhysicalMemoryElementName] Enabled on Subsystem [MemoryElementName].**

Memory has been enabled.

**Severity**

Info

**Serviceable**

No

**Automatically notify support**

No

**Alert Category**

System - Other

**SNMP Trap ID****CIM Information**

Prefix: PLAT ID: 0130

**User Response**

Information only; no action is required.

**Related links**

– “Finding the UEFI diagnostic code” on page 776

- **816f040c-2003ffff : [PhysicalMemoryElementName] Enabled on Subsystem [MemoryElementName].**

Memory has been enabled.

**Severity**

Info

**Serviceable**

No

**Automatically notify support**

No

**Alert Category**

System - Other

**SNMP Trap ID****CIM Information**

Prefix: PLAT ID: 0130

**User Response**

Information only; no action is required.

**Related links**

- "Finding the UEFI diagnostic code" on page 776
- **816f040c-2004ffff : [PhysicalMemoryElementName] Enabled on Subsystem [MemoryElementName].**

Memory has been enabled.

**Severity**

Info

**Serviceable**

No

**Automatically notify support**

No

**Alert Category**

System - Other

**SNMP Trap ID**

**CIM Information**

Prefix: PLAT ID: 0130

**User Response**

Information only; no action is required.

**Related links**

- "Finding the UEFI diagnostic code" on page 776
- **816f040c-2005ffff : [PhysicalMemoryElementName] Enabled on Subsystem [MemoryElementName].**

Memory has been enabled.

**Severity**

Info

**Serviceable**

No

**Automatically notify support**

No

**Alert Category**

System - Other

**SNMP Trap ID**

**CIM Information**

Prefix: PLAT ID: 0130

**User Response**

Information only; no action is required.

**Related links**

- "Finding the UEFI diagnostic code" on page 776
- **816f040c-2006ffff : [PhysicalMemoryElementName] Enabled on Subsystem [MemoryElementName].**

Memory has been enabled.

**Severity**

Info



**Serviceable**

No

**Automatically notify support**

No

**Alert Category**

System - Other

**SNMP Trap ID****CIM Information**

Prefix: PLAT ID: 0130

**User Response**

Information only; no action is required.

**Related links**

- "Finding the UEFI diagnostic code" on page 776
- **816f040c-2007ffff : [PhysicalMemoryElementName] Enabled on Subsystem [MemoryElementName].**  
Memory has been enabled.

**Severity**

Info

**Serviceable**

No

**Automatically notify support**

No

**Alert Category**

System - Other

**SNMP Trap ID****CIM Information**

Prefix: PLAT ID: 0130

**User Response**

Information only; no action is required.

**Related links**

- "Finding the UEFI diagnostic code" on page 776
- **816f040c-2008ffff : [PhysicalMemoryElementName] Enabled on Subsystem [MemoryElementName].**  
Memory has been enabled.

**Severity**

Info

**Serviceable**

No

**Automatically notify support**

No

**Alert Category**

System - Other

## SNMP Trap ID

### CIM Information

Prefix: PLAT ID: 0130

### User Response

Information only; no action is required.

### Related links

– “Finding the UEFI diagnostic code” on page 776

- **816f040c-2009ffff : [PhysicalMemoryElementName] Enabled on Subsystem [MemoryElementName].**

Memory has been enabled.

### Severity

Info

### Serviceable

No

### Automatically notify support

No

### Alert Category

System - Other

## SNMP Trap ID

### CIM Information

Prefix: PLAT ID: 0130

### User Response

Information only; no action is required.

### Related links

– “Finding the UEFI diagnostic code” on page 776

- **816f040c-200affff : [PhysicalMemoryElementName] Enabled on Subsystem [MemoryElementName].**

Memory has been enabled.

### Severity

Info

### Serviceable

No

### Automatically notify support

No

### Alert Category

System - Other

## SNMP Trap ID

### CIM Information

Prefix: PLAT ID: 0130

### User Response

Information only; no action is required.

**Related links**

– “Finding the UEFI diagnostic code” on page 776

- **816f040c-200bfff : [PhysicalMemoryElementName] Enabled on Subsystem [MemoryElementName].**

Memory has been enabled.

**Severity**

Info

**Serviceable**

No

**Automatically notify support**

No

**Alert Category**

System - Other

**SNMP Trap ID****CIM Information**

Prefix: PLAT ID: 0130

**User Response**

Information only; no action is required.

**Related links**

– “Finding the UEFI diagnostic code” on page 776

- **816f040c-200cfff : [PhysicalMemoryElementName] Enabled on Subsystem [MemoryElementName].**

Memory has been enabled.

**Severity**

Info

**Serviceable**

No

**Automatically notify support**

No

**Alert Category**

System - Other

**SNMP Trap ID****CIM Information**

Prefix: PLAT ID: 0130

**User Response**

Information only; no action is required.

**Related links**

– “Finding the UEFI diagnostic code” on page 776

- **816f040c-200dfff : [PhysicalMemoryElementName] Enabled on Subsystem [MemoryElementName].**

Memory has been enabled.

**Severity**

Info

**Serviceable**

No

**Automatically notify support**

No

**Alert Category**

System - Other

**SNMP Trap ID**

**CIM Information**

Prefix: PLAT ID: 0130

**User Response**

Information only; no action is required.

**Related links**

– “Finding the UEFI diagnostic code” on page 776

- **816f040c-200effff : [PhysicalMemoryElementName] Enabled on Subsystem [MemoryElementName].**

Memory has been enabled.

**Severity**

Info

**Serviceable**

No

**Automatically notify support**

No

**Alert Category**

System - Other

**SNMP Trap ID**

**CIM Information**

Prefix: PLAT ID: 0130

**User Response**

Information only; no action is required.

**Related links**

– “Finding the UEFI diagnostic code” on page 776

- **816f040c-200fffff : [PhysicalMemoryElementName] Enabled on Subsystem [MemoryElementName].**

Memory has been enabled.

**Severity**

Info

**Serviceable**

No

**Automatically notify support**

No

**Alert Category**

System - Other

**SNMP Trap ID**

**CIM Information**

**Prefix:** PLAT ID: 0130

**User Response**

Information only; no action is required.

**Related links**

- "Finding the UEFI diagnostic code" on page 776
- **816f040c-2010ffff : [PhysicalMemoryElementName] Enabled on Subsystem [MemoryElementName].**

Memory has been enabled.

**Severity**

Info

**Serviceable**

No

**Automatically notify support**

No

**Alert Category**

System - Other

**SNMP Trap ID**

**CIM Information**

**Prefix:** PLAT ID: 0130

**User Response**

Information only; no action is required.

**Related links**

- "Finding the UEFI diagnostic code" on page 776
- **816f040c-2011ffff : [PhysicalMemoryElementName] Enabled on Subsystem [MemoryElementName].**

Memory has been enabled.

**Severity**

Info

**Serviceable**

No

**Automatically notify support**

No

**Alert Category**

System - Other

**SNMP Trap ID**

**CIM Information**

**Prefix:** PLAT ID: 0130

**User Response**

Information only; no action is required.

**Related links**

– “Finding the UEFI diagnostic code” on page 776

- **816f040c-2012ffff : [PhysicalMemoryElementName] Enabled on Subsystem [MemoryElementName].**

Memory has been enabled.

**Severity**

Info

**Serviceable**

No

**Automatically notify support**

No

**Alert Category**

System - Other

**SNMP Trap ID**

**CIM Information**

Prefix: PLAT ID: 0130

**User Response**

Information only; no action is required.

**Related links**

– “Finding the UEFI diagnostic code” on page 776

- **816f040c-2013ffff : [PhysicalMemoryElementName] Enabled on Subsystem [MemoryElementName].**

Memory has been enabled.

**Severity**

Info

**Serviceable**

No

**Automatically notify support**

No

**Alert Category**

System - Other

**SNMP Trap ID**

**CIM Information**

Prefix: PLAT ID: 0130

**User Response**

Information only; no action is required.

**Related links**

– “Finding the UEFI diagnostic code” on page 776

- **816f040c-2014ffff : [PhysicalMemoryElementName] Enabled on Subsystem [MemoryElementName].**

Memory has been enabled.

**Severity**

Info

**Serviceable**

No

**Automatically notify support**

No

**Alert Category**

System - Other

**SNMP Trap ID****CIM Information****Prefix:** PLAT ID: 0130**User Response**

Information only; no action is required.

**Related links**

– “Finding the UEFI diagnostic code” on page 776

- **816f040c-2015ffff : [PhysicalMemoryElementName] Enabled on Subsystem [MemoryElementName].**

Memory has been enabled.

**Severity**

Info

**Serviceable**

No

**Automatically notify support**

No

**Alert Category**

System - Other

**SNMP Trap ID****CIM Information****Prefix:** PLAT ID: 0130**User Response**

Information only; no action is required.

**Related links**

– “Finding the UEFI diagnostic code” on page 776

- **816f040c-2016ffff : [PhysicalMemoryElementName] Enabled on Subsystem [MemoryElementName].**

Memory has been enabled.

**Severity**

Info

**Serviceable**

No

**Automatically notify support**

No

**Alert Category**

System - Other

**SNMP Trap ID****CIM Information**

Prefix: PLAT ID: 0130

**User Response**

Information only; no action is required.

**Related links**

– “Finding the UEFI diagnostic code” on page 776

- **816f040c-2017ffff : [PhysicalMemoryElementName] Enabled on Subsystem [MemoryElementName].**

Memory has been enabled.

**Severity**

Info

**Serviceable**

No

**Automatically notify support**

No

**Alert Category**

System - Other

**SNMP Trap ID****CIM Information**

Prefix: PLAT ID: 0130

**User Response**

Information only; no action is required.

**Related links**

– “Finding the UEFI diagnostic code” on page 776

- **816f040c-2018ffff : [PhysicalMemoryElementName] Enabled on Subsystem [MemoryElementName].**

Memory has been enabled.

**Severity**

Info

**Serviceable**

No

**Automatically notify support**

No

**Alert Category**

System - Other

**SNMP Trap ID****CIM Information**

Prefix: PLAT ID: 0130



**User Response**

Information only; no action is required.

**Related links**

– “Finding the UEFI diagnostic code” on page 776

- **816f040c-2019ffff : [PhysicalMemoryElementName] Enabled on Subsystem [MemoryElementName].**

Memory has been enabled.

**Severity**

Info

**Serviceable**

No

**Automatically notify support**

No

**Alert Category**

System - Other

**SNMP Trap ID****CIM Information**

Prefix: PLAT ID: 0130

**User Response**

Information only; no action is required.

**Related links**

– “Finding the UEFI diagnostic code” on page 776

- **816f040c-201affff : [PhysicalMemoryElementName] Enabled on Subsystem [MemoryElementName].**

Memory has been enabled.

**Severity**

Info

**Serviceable**

No

**Automatically notify support**

No

**Alert Category**

System - Other

**SNMP Trap ID****CIM Information**

Prefix: PLAT ID: 0130

**User Response**

Information only; no action is required.

**Related links**

– “Finding the UEFI diagnostic code” on page 776

- **816f040c-201bffff : [PhysicalMemoryElementName] Enabled on Subsystem [MemoryElementName].**

Memory has been enabled.

**Severity**

Info

**Serviceable**

No

**Automatically notify support**

No

**Alert Category**

System - Other

**SNMP Trap ID**

**CIM Information**

Prefix: PLAT ID: 0130

**User Response**

Information only; no action is required.

**Related links**

– “Finding the UEFI diagnostic code” on page 776

- **816f040c-201cffff : [PhysicalMemoryElementName] Enabled on Subsystem [MemoryElementName].**

Memory has been enabled.

**Severity**

Info

**Serviceable**

No

**Automatically notify support**

No

**Alert Category**

System - Other

**SNMP Trap ID**

**CIM Information**

Prefix: PLAT ID: 0130

**User Response**

Information only; no action is required.

**Related links**

– “Finding the UEFI diagnostic code” on page 776

- **816f040c-201dffff : [PhysicalMemoryElementName] Enabled on Subsystem [MemoryElementName].**

Memory has been enabled.

**Severity**

Info

**Serviceable**

No

**Automatically notify support**

No

**Alert Category**

System - Other

**SNMP Trap ID****CIM Information**

Prefix: PLAT ID: 0130

**User Response**

Information only; no action is required.

**Related links**

– “Finding the UEFI diagnostic code” on page 776

- **816f040c-201efff : [PhysicalMemoryElementName] Enabled on Subsystem [MemoryElementName].**

Memory has been enabled.

**Severity**

Info

**Serviceable**

No

**Automatically notify support**

No

**Alert Category**

System - Other

**SNMP Trap ID****CIM Information**

Prefix: PLAT ID: 0130

**User Response**

Information only; no action is required.

**Related links**

– “Finding the UEFI diagnostic code” on page 776

- **816f040c-201ffff : [PhysicalMemoryElementName] Enabled on Subsystem [MemoryElementName].**

Memory has been enabled.

**Severity**

Info

**Serviceable**

No

**Automatically notify support**

No

**Alert Category**

System - Other

**SNMP Trap ID**

**CIM Information**

Prefix: PLAT ID: 0130

**User Response**

Information only; no action is required.

**Related links**

– “Finding the UEFI diagnostic code” on page 776

- **816f040c-2020ffff : [PhysicalMemoryElementName] Enabled on Subsystem [MemoryElementName].**

Memory has been enabled.

**Severity**

Info

**Serviceable**

No

**Automatically notify support**

No

**Alert Category**

System - Other

**SNMP Trap ID****CIM Information**

Prefix: PLAT ID: 0130

**User Response**

Information only; no action is required.

**Related links**

– “Finding the UEFI diagnostic code” on page 776

- **816f040c-2021ffff : [PhysicalMemoryElementName] Enabled on Subsystem [MemoryElementName].**

Memory has been enabled.

**Severity**

Info

**Serviceable**

No

**Automatically notify support**

No

**Alert Category**

System - Other

**SNMP Trap ID****CIM Information**

Prefix: PLAT ID: 0130

**User Response**

Information only; no action is required.

**Related links**

– “Finding the UEFI diagnostic code” on page 776

- **816f040c-2022ffff : [PhysicalMemoryElementName] Enabled on Subsystem [MemoryElementName].**

Memory has been enabled.

**Severity**

Info

**Serviceable**

No

**Automatically notify support**

No

**Alert Category**

System - Other

**SNMP Trap ID**

**CIM Information**

Prefix: PLAT ID: 0130

**User Response**

Information only; no action is required.

**Related links**

– “Finding the UEFI diagnostic code” on page 776

- **816f040c-2023ffff : [PhysicalMemoryElementName] Enabled on Subsystem [MemoryElementName].**

Memory has been enabled.

**Severity**

Info

**Serviceable**

No

**Automatically notify support**

No

**Alert Category**

System - Other

**SNMP Trap ID**

**CIM Information**

Prefix: PLAT ID: 0130

**User Response**

Information only; no action is required.

**Related links**

– “Finding the UEFI diagnostic code” on page 776

- **816f040c-2024ffff : [PhysicalMemoryElementName] Enabled on Subsystem [MemoryElementName].**

Memory has been enabled.

**Severity**

Info

**Serviceable**

No

**Automatically notify support**

No

**Alert Category**

System - Other

**SNMP Trap ID****CIM Information**

Prefix: PLAT ID: 0130

**User Response**

Information only; no action is required.

**Related links**

– “Finding the UEFI diagnostic code” on page 776

- **816f040c-2025ffff : [PhysicalMemoryElementName] Enabled on Subsystem [MemoryElementName].**

Memory has been enabled.

**Severity**

Info

**Serviceable**

No

**Automatically notify support**

No

**Alert Category**

System - Other

**SNMP Trap ID****CIM Information**

Prefix: PLAT ID: 0130

**User Response**

Information only; no action is required.

**Related links**

– “Finding the UEFI diagnostic code” on page 776

- **816f040c-2026ffff : [PhysicalMemoryElementName] Enabled on Subsystem [MemoryElementName].**

Memory has been enabled.

**Severity**

Info

**Serviceable**

No

**Automatically notify support**

No

**Alert Category**

System - Other

## SNMP Trap ID

### CIM Information

Prefix: PLAT ID: 0130

### User Response

Information only; no action is required.

### Related links

- "Finding the UEFI diagnostic code" on page 776
- **816f040c-2027ffff : [PhysicalMemoryElementName] Enabled on Subsystem [MemoryElementName].**

Memory has been enabled.

### Severity

Info

### Serviceable

No

### Automatically notify support

No

### Alert Category

System - Other

## SNMP Trap ID

### CIM Information

Prefix: PLAT ID: 0130

### User Response

Information only; no action is required.

### Related links

- "Finding the UEFI diagnostic code" on page 776
- **816f040c-2028ffff : [PhysicalMemoryElementName] Enabled on Subsystem [MemoryElementName].**

Memory has been enabled.

### Severity

Info

### Serviceable

No

### Automatically notify support

No

### Alert Category

System - Other

## SNMP Trap ID

### CIM Information

Prefix: PLAT ID: 0130

### User Response

Information only; no action is required.

**Related links**

– “Finding the UEFI diagnostic code” on page 776

- **816f040c-2029ffff : [PhysicalMemoryElementName] Enabled on Subsystem [MemoryElementName].**

Memory has been enabled.

**Severity**

Info

**Serviceable**

No

**Automatically notify support**

No

**Alert Category**

System - Other

**SNMP Trap ID****CIM Information**

Prefix: PLAT ID: 0130

**User Response**

Information only; no action is required.

**Related links**

– “Finding the UEFI diagnostic code” on page 776

- **816f040c-202affff : [PhysicalMemoryElementName] Enabled on Subsystem [MemoryElementName].**

Memory has been enabled.

**Severity**

Info

**Serviceable**

No

**Automatically notify support**

No

**Alert Category**

System - Other

**SNMP Trap ID****CIM Information**

Prefix: PLAT ID: 0130

**User Response**

Information only; no action is required.

**Related links**

– “Finding the UEFI diagnostic code” on page 776

- **816f040c-202bffff : [PhysicalMemoryElementName] Enabled on Subsystem [MemoryElementName].**

Memory has been enabled.

**Severity**



Info

**Serviceable**

No

**Automatically notify support**

No

**Alert Category**

System - Other

**SNMP Trap ID**

**CIM Information**

Prefix: PLAT ID: 0130

**User Response**

Information only; no action is required.

**Related links**

– “Finding the UEFI diagnostic code” on page 776

- **816f040c-202cffff : [PhysicalMemoryElementName] Enabled on Subsystem [MemoryElementName].**

Memory has been enabled.

**Severity**

Info

**Serviceable**

No

**Automatically notify support**

No

**Alert Category**

System - Other

**SNMP Trap ID**

**CIM Information**

Prefix: PLAT ID: 0130

**User Response**

Information only; no action is required.

**Related links**

– “Finding the UEFI diagnostic code” on page 776

- **816f040c-202dffff : [PhysicalMemoryElementName] Enabled on Subsystem [MemoryElementName].**

Memory has been enabled.

**Severity**

Info

**Serviceable**

No

**Automatically notify support**

No

**Alert Category**

System - Other

### SNMP Trap ID

#### CIM Information

Prefix: PLAT ID: 0130

#### User Response

Information only; no action is required.

#### Related links

– “Finding the UEFI diagnostic code” on page 776

- **816f040c-202effff : [PhysicalMemoryElementName] Enabled on Subsystem [MemoryElementName].**

Memory has been enabled.

#### Severity

Info

#### Serviceable

No

#### Automatically notify support

No

#### Alert Category

System - Other

### SNMP Trap ID

#### CIM Information

Prefix: PLAT ID: 0130

#### User Response

Information only; no action is required.

#### Related links

– “Finding the UEFI diagnostic code” on page 776

- **816f040c-202fffff : [PhysicalMemoryElementName] Enabled on Subsystem [MemoryElementName].**

Memory has been enabled.

#### Severity

Info

#### Serviceable

No

#### Automatically notify support

No

#### Alert Category

System - Other

### SNMP Trap ID

#### CIM Information

Prefix: PLAT ID: 0130

#### User Response

Information only; no action is required.

**Related links**

– “Finding the UEFI diagnostic code” on page 776

- **816f040c-2030ffff : [PhysicalMemoryElementName] Enabled on Subsystem [MemoryElementName].**

Memory has been enabled.

**Severity**

Info

**Serviceable**

No

**Automatically notify support**

No

**Alert Category**

System - Other

**SNMP Trap ID**

**CIM Information**

Prefix: PLAT ID: 0130

**User Response**

Information only; no action is required.

**Related links**

– “Finding the UEFI diagnostic code” on page 776

- **816f040c-2581ffff : [PhysicalMemoryElementName] Enabled on Subsystem [MemoryElementName].**

Memory has been enabled. All DIMMs. One of the DIMMs.

**Severity**

Info

**Serviceable**

No

**Automatically notify support**

No

**Alert Category**

System - Other

**SNMP Trap ID**

**CIM Information**

Prefix: PLAT ID: 0130

**User Response**

Information only; no action is required.

**Related links**

– “Finding the UEFI diagnostic code” on page 776

- **816f0413-2582ffff : A PCI PERR recovery has occurred on system [ComputerSystemElementName].**

A PCI Parity Error (PERR) has recovered. All PCI Error. One of PCI Error.

**Severity**

Info

**Serviceable**

No

**Automatically notify support**

No

**Alert Category**

Critical - Other

**SNMP Trap ID**

50

**CIM Information****Prefix: PLAT ID:** 0233**User Response**

Information only; no action is required.

**Related links**

– “Finding the UEFI diagnostic code” on page 776

- **816f0507-0301ffff : [ProcessorElementName] has Recovered from a Configuration Mismatch.**

A Processor Configuration Mismatch has recovered.

**Severity**

Info

**Serviceable**

No

**Automatically notify support**

No

**Alert Category**

Critical - CPU

**SNMP Trap ID**

40

**CIM Information****Prefix: PLAT ID:** 0063**User Response**

Information only; no action is required.

**Related links**

– “Finding the UEFI diagnostic code” on page 776

- **816f0507-0302ffff : [ProcessorElementName] has Recovered from a Configuration Mismatch.**

A Processor Configuration Mismatch has occurred.

**Severity**

Info

**Serviceable**

No

**Automatically notify support**

No

**Alert Category**

Critical - CPU

**SNMP Trap ID**

40

**CIM Information****Prefix:** PLAT ID: 0063**User Response**

Information only; no action is required.

**Related links**

– “Finding the UEFI diagnostic code” on page 776

- **816f0507-0303ffff : [ProcessorElementName] has Recovered from a Configuration Mismatch.**

A Processor Configuration Mismatch has recovered.

**Severity**

Info

**Serviceable**

No

**Automatically notify support**

No

**Alert Category**

Critical - CPU

**SNMP Trap ID**

40

**CIM Information****Prefix:** PLAT ID: 0063**User Response**

Information only; no action is required.

**Related links**

– “Finding the UEFI diagnostic code” on page 776

- **816f0507-0304ffff : [ProcessorElementName] has Recovered from a Configuration Mismatch.**

A Processor Configuration Mismatch has recovered.

**Severity**

Info

**Serviceable**

No

**Automatically notify support**

No

**Alert Category**

Critical - CPU

**SNMP Trap ID**

40

**CIM Information****Prefix:** PLAT ID: 0063**User Response**

Information only; no action is required.

**Related links**

– “Finding the UEFI diagnostic code” on page 776

- **816f0507-2584ffff : [ProcessorElementName] has Recovered from a Configuration Mismatch.**

A processor configuration mismatch has recovered. All CPUs. One of CPUs.

**Severity**

Info

**Serviceable**

No

**Automatically notify support**

No

**Alert Category**

Critical - CPU

**SNMP Trap ID**

40

**CIM Information**

Prefix: PLAT ID: 0063

**User Response**

Information only; no action is required.

**Related links**

– “Finding the UEFI diagnostic code” on page 776

- **816f050c-2001ffff : Memory Logging Limit Removed for [PhysicalMemoryElementName] on Subsystem [MemoryElementName].**

the memory logging limit has been removed.

**Severity**

Info

**Serviceable**

No

**Automatically notify support**

No

**Alert Category**

Warning - Memory

**SNMP Trap ID**

43

**CIM Information**

Prefix: PLAT ID: 0145

**User Response**

Information only; no action is required.

**Related links**

– “Finding the UEFI diagnostic code” on page 776

- **816f050c-2002ffff : Memory Logging Limit Removed for [PhysicalMemoryElementName] on Subsystem [MemoryElementName].**

the memory logging limit has been removed.

**Severity**

Info

**Serviceable**

No

**Automatically notify support**

No

**Alert Category**

Warning - Memory

**SNMP Trap ID**

43

**CIM Information**

**Prefix:** PLAT ID: 0145

**User Response**

Information only; no action is required.

**Related links**

– “Finding the UEFI diagnostic code” on page 776

- **816f050c-2003ffff : Memory Logging Limit Removed for [PhysicalMemoryElementName] on Subsystem [MemoryElementName].**

the memory logging limit has been removed.

**Severity**

Info

**Serviceable**

No

**Automatically notify support**

No

**Alert Category**

Warning - Memory

**SNMP Trap ID**

43

**CIM Information**

**Prefix:** PLAT ID: 0145

**User Response**

Information only; no action is required.

**Related links**

– “Finding the UEFI diagnostic code” on page 776

- **816f050c-2004ffff : Memory Logging Limit Removed for [PhysicalMemoryElementName] on Subsystem [MemoryElementName].**

the memory logging limit has been removed.

**Severity**

Info

**Serviceable**

No

**Automatically notify support**

No

**Alert Category**

Warning - Memory

**SNMP Trap ID**

**CIM Information****Prefix:** PLAT ID: 0145**User Response**

Information only; no action is required.

**Related links**

– “Finding the UEFI diagnostic code” on page 776

- **816f050c-2005ffff : Memory Logging Limit Removed for [PhysicalMemoryElementName] on Subsystem [MemoryElementName].**

the memory logging limit has been removed.

**Severity**

Info

**Serviceable**

No

**Automatically notify support**

No

**Alert Category**

Warning - Memory

**SNMP Trap ID**

43

**CIM Information****Prefix:** PLAT ID: 0145**User Response**

Information only; no action is required.

**Related links**

– “Finding the UEFI diagnostic code” on page 776

- **816f050c-2006ffff : Memory Logging Limit Removed for [PhysicalMemoryElementName] on Subsystem [MemoryElementName].**

the memory logging limit has been removed.

**Severity**

Info

**Serviceable**

No

**Automatically notify support**

No

**Alert Category**

Warning - Memory

**SNMP Trap ID**

43

**CIM Information****Prefix:** PLAT ID: 0145**User Response**

Information only; no action is required.

**Related links**



– “Finding the UEFI diagnostic code” on page 776

- **816f050c-2007ffff : Memory Logging Limit Removed for [PhysicalMemoryElementName] on Subsystem [MemoryElementName].**

the memory logging limit has been removed.

**Severity**

Info

**Serviceable**

No

**Automatically notify support**

No

**Alert Category**

Warning - Memory

**SNMP Trap ID**

43

**CIM Information**

Prefix: PLAT ID: 0145

**User Response**

Information only; no action is required.

**Related links**

– “Finding the UEFI diagnostic code” on page 776

- **816f050c-2008ffff : Memory Logging Limit Removed for [PhysicalMemoryElementName] on Subsystem [MemoryElementName].**

the memory logging limit has been removed.

**Severity**

Info

**Serviceable**

No

**Automatically notify support**

No

**Alert Category**

Warning - Memory

**SNMP Trap ID**

43

**CIM Information**

Prefix: PLAT ID: 0145

**User Response**

Information only; no action is required.

**Related links**

– “Finding the UEFI diagnostic code” on page 776

- **816f050c-2009ffff : Memory Logging Limit Removed for [PhysicalMemoryElementName] on Subsystem [MemoryElementName].**

the memory logging limit has been removed.

**Severity**

Info

**Serviceable**

No

**Automatically notify support**

No

**Alert Category**

Warning - Memory

**SNMP Trap ID**

43

**CIM Information**

Prefix: PLAT ID: 0145

**User Response**

Information only; no action is required.

**Related links**

– “Finding the UEFI diagnostic code” on page 776

- **816f050c-200affff : Memory Logging Limit Removed for [PhysicalMemoryElementName] on Subsystem [MemoryElementName].**

the memory logging limit has been removed.

**Severity**

Info

**Serviceable**

No

**Automatically notify support**

No

**Alert Category**

Warning - Memory

**SNMP Trap ID**

43

**CIM Information**

Prefix: PLAT ID: 0145

**User Response**

Information only; no action is required.

**Related links**

– “Finding the UEFI diagnostic code” on page 776

- **816f050c-200bffff : Memory Logging Limit Removed for [PhysicalMemoryElementName] on Subsystem [MemoryElementName].**

the memory logging limit has been removed.

**Severity**

Info

**Serviceable**

No

**Automatically notify support**

No

**Alert Category**

Warning - Memory

**SNMP Trap ID**

43

**CIM Information****Prefix:** PLAT ID: 0145**User Response**

Information only; no action is required.

**Related links**

- "Finding the UEFI diagnostic code" on page 776
- **816f050c-200cffff : Memory Logging Limit Removed for [PhysicalMemoryElementName] on Subsystem [MemoryElementName].**

the memory logging limit has been removed.

**Severity**

Info

**Serviceable**

No

**Automatically notify support**

No

**Alert Category**

Warning - Memory

**SNMP Trap ID**

43

**CIM Information****Prefix:** PLAT ID: 0145**User Response**

Information only; no action is required.

**Related links**

- "Finding the UEFI diagnostic code" on page 776
- **816f050c-200dffff : Memory Logging Limit Removed for [PhysicalMemoryElementName] on Subsystem [MemoryElementName].**

the memory logging limit has been removed.

**Severity**

Info

**Serviceable**

No

**Automatically notify support**

No

**Alert Category**

Warning - Memory

**SNMP Trap ID**

43

**CIM Information****Prefix:** PLAT ID: 0145**User Response**

Information only; no action is required.

**Related links**

– “Finding the UEFI diagnostic code” on page 776

- **816f050c-200effff : Memory Logging Limit Removed for [PhysicalMemoryElementName] on Subsystem [MemoryElementName].**

the memory logging limit has been removed.

**Severity**

Info

**Serviceable**

No

**Automatically notify support**

No

**Alert Category**

Warning - Memory

**SNMP Trap ID**

43

**CIM Information**

Prefix: PLAT ID: 0145

**User Response**

Information only; no action is required.

**Related links**

– “Finding the UEFI diagnostic code” on page 776

- **816f050c-200fffff : Memory Logging Limit Removed for [PhysicalMemoryElementName] on Subsystem [MemoryElementName].**

the memory logging limit has been removed.

**Severity**

Info

**Serviceable**

No

**Automatically notify support**

No

**Alert Category**

Warning - Memory

**SNMP Trap ID**

43

**CIM Information**

Prefix: PLAT ID: 0145

**User Response**

Information only; no action is required.

**Related links**

– “Finding the UEFI diagnostic code” on page 776

- **816f050c-2010ffff : Memory Logging Limit Removed for [PhysicalMemoryElementName] on Subsystem [MemoryElementName].**

the memory logging limit has been removed.

**Severity**

Info

**Serviceable**

No

**Automatically notify support**

No

**Alert Category**

Warning - Memory

**SNMP Trap ID**

43

**CIM Information**

**Prefix:** PLAT ID: 0145

**User Response**

Information only; no action is required.

**Related links**

– “Finding the UEFI diagnostic code” on page 776

- **816f050c-2011ffff : Memory Logging Limit Removed for [PhysicalMemoryElementName] on Subsystem [MemoryElementName].**

the memory logging limit has been removed.

**Severity**

Info

**Serviceable**

No

**Automatically notify support**

No

**Alert Category**

Warning - Memory

**SNMP Trap ID**

43

**CIM Information**

**Prefix:** PLAT ID: 0145

**User Response**

Information only; no action is required.

**Related links**

– “Finding the UEFI diagnostic code” on page 776

- **816f050c-2012ffff : Memory Logging Limit Removed for [PhysicalMemoryElementName] on Subsystem [MemoryElementName].**

the memory logging limit has been removed.

**Severity**

Info

**Serviceable**

No

**Automatically notify support**

No

**Alert Category**

Warning - Memory

**SNMP Trap ID**

43

**CIM Information**

Prefix: PLAT ID: 0145

**User Response**

Information only; no action is required.

**Related links**

– “Finding the UEFI diagnostic code” on page 776

- **816f050c-2013ffff : Memory Logging Limit Removed for [PhysicalMemoryElementName] on Subsystem [MemoryElementName].**

the memory logging limit has been removed.

**Severity**

Info

**Serviceable**

No

**Automatically notify support**

No

**Alert Category**

Warning - Memory

**SNMP Trap ID**

43

**CIM Information**

Prefix: PLAT ID: 0145

**User Response**

Information only; no action is required.

**Related links**

– “Finding the UEFI diagnostic code” on page 776

- **816f050c-2014ffff : Memory Logging Limit Removed for [PhysicalMemoryElementName] on Subsystem [MemoryElementName].**

the memory logging limit has been removed.

**Severity**

Info

**Serviceable**

No

**Automatically notify support**

No

**Alert Category**

Warning - Memory

**SNMP Trap ID**

43

**CIM Information**

Prefix: PLAT ID: 0145

**User Response**

Information only; no action is required.

**Related links**

– “Finding the UEFI diagnostic code” on page 776

- **816f050c-2015ffff : Memory Logging Limit Removed for [PhysicalMemoryElementName] on Subsystem [MemoryElementName].**

the memory logging limit has been removed.

**Severity**

Info

**Serviceable**

No

**Automatically notify support**

No

**Alert Category**

Warning - Memory

**SNMP Trap ID**

43

**CIM Information**

**Prefix:** PLAT ID: 0145

**User Response**

Information only; no action is required.

**Related links**

– “Finding the UEFI diagnostic code” on page 776

- **816f050c-2016ffff : Memory Logging Limit Removed for [PhysicalMemoryElementName] on Subsystem [MemoryElementName].**

the memory logging limit has been removed.

**Severity**

Info

**Serviceable**

No

**Automatically notify support**

No

**Alert Category**

Warning - Memory

**SNMP Trap ID**

43

**CIM Information**

**Prefix:** PLAT ID: 0145

**User Response**

Information only; no action is required.

**Related links**

– “Finding the UEFI diagnostic code” on page 776

- **816f050c-2017ffff : Memory Logging Limit Removed for [PhysicalMemoryElementName] on Subsystem [MemoryElementName].**

the memory logging limit has been removed.

**Severity**

Info

**Serviceable**

No

**Automatically notify support**

No

**Alert Category**

Warning - Memory

**SNMP Trap ID**

43

**CIM Information**

Prefix: PLAT ID: 0145

**User Response**

Information only; no action is required.

**Related links**

– “Finding the UEFI diagnostic code” on page 776

- **816f050c-2018ffff : Memory Logging Limit Removed for [PhysicalMemoryElementName] on Subsystem [MemoryElementName].**

the memory logging limit has been removed.

**Severity**

Info

**Serviceable**

No

**Automatically notify support**

No

**Alert Category**

Warning - Memory

**SNMP Trap ID**

43

**CIM Information**

Prefix: PLAT ID: 0145

**User Response**

Information only; no action is required.

**Related links**

– “Finding the UEFI diagnostic code” on page 776

- **816f050c-2019ffff : Memory Logging Limit Removed for [PhysicalMemoryElementName] on Subsystem [MemoryElementName].**

the memory logging limit has been removed.

**Severity**

Info

**Serviceable**

No

**Automatically notify support**

No



**Alert Category**

Warning - Memory

**SNMP Trap ID**

43

**CIM Information**

**Prefix:** PLAT ID: 0145

**User Response**

Information only; no action is required.

**Related links**

– “Finding the UEFI diagnostic code” on page 776

- **816f050c-201afff : Memory Logging Limit Removed for [PhysicalMemoryElementName] on Subsystem [MemoryElementName].**

the memory logging limit has been removed.

**Severity**

Info

**Serviceable**

No

**Automatically notify support**

No

**Alert Category**

Warning - Memory

**SNMP Trap ID**

43

**CIM Information**

**Prefix:** PLAT ID: 0145

**User Response**

Information only; no action is required.

**Related links**

– “Finding the UEFI diagnostic code” on page 776

- **816f050c-201bfff : Memory Logging Limit Removed for [PhysicalMemoryElementName] on Subsystem [MemoryElementName].**

the memory logging limit has been removed.

**Severity**

Info

**Serviceable**

No

**Automatically notify support**

No

**Alert Category**

Warning - Memory

**SNMP Trap ID**

43

**CIM Information**

**Prefix:** PLAT ID: 0145

**User Response**

Information only; no action is required.

**Related links**

– “Finding the UEFI diagnostic code” on page 776

- **816f050c-201cffff : Memory Logging Limit Removed for [PhysicalMemoryElementName] on Subsystem [MemoryElementName].**

the memory logging limit has been removed.

**Severity**

Info

**Serviceable**

No

**Automatically notify support**

No

**Alert Category**

Warning - Memory

**SNMP Trap ID**

43

**CIM Information**

Prefix: PLAT ID: 0145

**User Response**

Information only; no action is required.

**Related links**

– “Finding the UEFI diagnostic code” on page 776

- **816f050c-201dffff : Memory Logging Limit Removed for [PhysicalMemoryElementName] on Subsystem [MemoryElementName].**

the memory logging limit has been removed.

**Severity**

Info

**Serviceable**

No

**Automatically notify support**

No

**Alert Category**

Warning - Memory

**SNMP Trap ID**

43

**CIM Information**

Prefix: PLAT ID: 0145

**User Response**

Information only; no action is required.

**Related links**

– “Finding the UEFI diagnostic code” on page 776

- **816f050c-201effff : Memory Logging Limit Removed for [PhysicalMemoryElementName] on Subsystem [MemoryElementName].**

the memory logging limit has been removed.

**Severity**

Info

**Serviceable**

No

**Automatically notify support**

No

**Alert Category**

Warning - Memory

**SNMP Trap ID**

43

**CIM Information**

**Prefix:** PLAT ID: 0145

**User Response**

Information only; no action is required.

**Related links**

– “Finding the UEFI diagnostic code” on page 776

- **816f050c-201ffff : Memory Logging Limit Removed for [PhysicalMemoryElementName] on Subsystem [MemoryElementName].**

the memory logging limit has been removed.

**Severity**

Info

**Serviceable**

No

**Automatically notify support**

No

**Alert Category**

Warning - Memory

**SNMP Trap ID**

43

**CIM Information**

**Prefix:** PLAT ID: 0145

**User Response**

Information only; no action is required.

**Related links**

– “Finding the UEFI diagnostic code” on page 776

- **816f050c-2020ffff : Memory Logging Limit Removed for [PhysicalMemoryElementName] on Subsystem [MemoryElementName].**

the memory logging limit has been removed.

**Severity**

Info

**Serviceable**

No

**Automatically notify support**

No

**Alert Category**

Warning - Memory

**SNMP Trap ID**

43

**CIM Information**

Prefix: PLAT ID: 0145

**User Response**

Information only; no action is required.

**Related links**

– “Finding the UEFI diagnostic code” on page 776

- **816f050c-2021ffff : Memory Logging Limit Removed for [PhysicalMemoryElementName] on Subsystem [MemoryElementName].**

the memory logging limit has been removed.

**Severity**

Info

**Serviceable**

No

**Automatically notify support**

No

**Alert Category**

Warning - Memory

**SNMP Trap ID**

43

**CIM Information**

Prefix: PLAT ID: 0145

**User Response**

Information only; no action is required.

**Related links**

– “Finding the UEFI diagnostic code” on page 776

- **816f050c-2022ffff : Memory Logging Limit Removed for [PhysicalMemoryElementName] on Subsystem [MemoryElementName].**

the memory logging limit has been removed.

**Severity**

Info

**Serviceable**

No

**Automatically notify support**

No

**Alert Category**

Warning - Memory

**SNMP Trap ID**

43

**CIM Information**

Prefix: PLAT ID: 0145

**User Response**

Information only; no action is required.

**Related links**

– “Finding the UEFI diagnostic code” on page 776

- **816f050c-2023ffff : Memory Logging Limit Removed for [PhysicalMemoryElementName] on Subsystem [MemoryElementName].**

the memory logging limit has been removed.

**Severity**

Info

**Serviceable**

No

**Automatically notify support**

No

**Alert Category**

Warning - Memory

**SNMP Trap ID**

43

**CIM Information**

Prefix: PLAT ID: 0145

**User Response**

Information only; no action is required.

**Related links**

– “Finding the UEFI diagnostic code” on page 776

- **816f050c-2024ffff : Memory Logging Limit Removed for [PhysicalMemoryElementName] on Subsystem [MemoryElementName].**

the memory logging limit has been removed.

**Severity**

Info

**Serviceable**

No

**Automatically notify support**

No

**Alert Category**

Warning - Memory

**SNMP Trap ID**

43

**CIM Information**

Prefix: PLAT ID: 0145

**User Response**

Information only; no action is required.

**Related links**

– “Finding the UEFI diagnostic code” on page 776

- **816f050c-2025ffff : Memory Logging Limit Removed for [PhysicalMemoryElementName] on Subsystem [MemoryElementName].**

the memory logging limit has been removed.

**Severity**

Info

**Serviceable**

No

**Automatically notify support**

No

**Alert Category**

Warning - Memory

**SNMP Trap ID**

43

**CIM Information**

Prefix: PLAT ID: 0145

**User Response**

Information only; no action is required.

**Related links**

– “Finding the UEFI diagnostic code” on page 776

- **816f050c-2026ffff : Memory Logging Limit Removed for [PhysicalMemoryElementName] on Subsystem [MemoryElementName].**

the memory logging limit has been removed.

**Severity**

Info

**Serviceable**

No

**Automatically notify support**

No

**Alert Category**

Warning - Memory

**SNMP Trap ID**

43

**CIM Information**

Prefix: PLAT ID: 0145

**User Response**

Information only; no action is required.

**Related links**

– “Finding the UEFI diagnostic code” on page 776

- **816f050c-2027ffff : Memory Logging Limit Removed for [PhysicalMemoryElementName] on Subsystem [MemoryElementName].**

the memory logging limit has been removed.

**Severity**

Info

**Serviceable**

No

**Automatically notify support**

No

**Alert Category**

Warning - Memory

**SNMP Trap ID**

43

**CIM Information**

**Prefix:** PLAT ID: 0145

**User Response**

Information only; no action is required.

**Related links**

- "Finding the UEFI diagnostic code" on page 776
- **816f050c-2028ffff : Memory Logging Limit Removed for [PhysicalMemoryElementName] on Subsystem [MemoryElementName].**

the memory logging limit has been removed.

**Severity**

Info

**Serviceable**

No

**Automatically notify support**

No

**Alert Category**

Warning - Memory

**SNMP Trap ID**

43

**CIM Information**

**Prefix:** PLAT ID: 0145

**User Response**

Information only; no action is required.

**Related links**

- "Finding the UEFI diagnostic code" on page 776
- **816f050c-2029ffff : Memory Logging Limit Removed for [PhysicalMemoryElementName] on Subsystem [MemoryElementName].**

the memory logging limit has been removed.

**Severity**

Info

**Serviceable**

No

**Automatically notify support**

No

**Alert Category**

Warning - Memory

**SNMP Trap ID**

43

**CIM Information**

Prefix: PLAT ID: 0145

**User Response**

Information only; no action is required.

**Related links**

– “Finding the UEFI diagnostic code” on page 776

- **816f050c-202affff : Memory Logging Limit Removed for [PhysicalMemoryElementName] on Subsystem [MemoryElementName].**

the memory logging limit has been removed.

**Severity**

Info

**Serviceable**

No

**Automatically notify support**

No

**Alert Category**

Warning - Memory

**SNMP Trap ID**

43

**CIM Information**

Prefix: PLAT ID: 0145

**User Response**

Information only; no action is required.

**Related links**

– “Finding the UEFI diagnostic code” on page 776

- **816f050c-202bffff : Memory Logging Limit Removed for [PhysicalMemoryElementName] on Subsystem [MemoryElementName].**

the memory logging limit has been removed.

**Severity**

Info

**Serviceable**

No

**Automatically notify support**

No

**Alert Category**

Warning - Memory

**SNMP Trap ID**

43

**CIM Information**

Prefix: PLAT ID: 0145

**User Response**

Information only; no action is required.



**Related links**

– “Finding the UEFI diagnostic code” on page 776

- **816f050c-202cffff : Memory Logging Limit Removed for [PhysicalMemoryElementName] on Subsystem [MemoryElementName].**

the memory logging limit has been removed.

**Severity**

Info

**Serviceable**

No

**Automatically notify support**

No

**Alert Category**

Warning - Memory

**SNMP Trap ID**

43

**CIM Information**

Prefix: PLAT ID: 0145

**User Response**

Information only; no action is required.

**Related links**

– “Finding the UEFI diagnostic code” on page 776

- **816f050c-202dffff : Memory Logging Limit Removed for [PhysicalMemoryElementName] on Subsystem [MemoryElementName].**

the memory logging limit has been removed.

**Severity**

Info

**Serviceable**

No

**Automatically notify support**

No

**Alert Category**

Warning - Memory

**SNMP Trap ID**

43

**CIM Information**

Prefix: PLAT ID: 0145

**User Response**

Information only; no action is required.

**Related links**

– “Finding the UEFI diagnostic code” on page 776

- **816f050c-202effff : Memory Logging Limit Removed for [PhysicalMemoryElementName] on Subsystem [MemoryElementName].**

the memory logging limit has been removed.

**Severity**

Info

**Serviceable**

No

**Automatically notify support**

No

**Alert Category**

Warning - Memory

**SNMP Trap ID**

43

**CIM Information**

**Prefix: PLAT ID:** 0145

**User Response**

Information only; no action is required.

**Related links**

– “Finding the UEFI diagnostic code” on page 776

- **816f050c-202ffff : Memory Logging Limit Removed for [PhysicalMemoryElementName] on Subsystem [MemoryElementName].**

the memory logging limit has been removed.

**Severity**

Info

**Serviceable**

No

**Automatically notify support**

No

**Alert Category**

Warning - Memory

**SNMP Trap ID**

43

**CIM Information**

**Prefix: PLAT ID:** 0145

**User Response**

Information only; no action is required.

**Related links**

– “Finding the UEFI diagnostic code” on page 776

- **816f050c-2030fff : Memory Logging Limit Removed for [PhysicalMemoryElementName] on Subsystem [MemoryElementName].**

the memory logging limit has been removed.

**Severity**

Info

**Serviceable**

No

**Automatically notify support**

No

**Alert Category**

Warning - Memory

**SNMP Trap ID**

43

**CIM Information**

**Prefix:** PLAT ID: 0145

**User Response**

Information only; no action is required.

**Related links**

– “Finding the UEFI diagnostic code” on page 776

- **816f050c-2581ffff : Memory Logging Limit Removed for [PhysicalMemoryElementName] on Subsystem [MemoryElementName].**

The memory logging limit has been removed. All DIMMs. One of the DIMMs.

**Severity**

Info

**Serviceable**

No

**Automatically notify support**

No

**Alert Category**

Warning - Memory

**SNMP Trap ID**

43

**CIM Information**

**Prefix:** PLAT ID: 0145

**User Response**

Information only; no action is required.

**Related links**

– “Finding the UEFI diagnostic code” on page 776

- **816f050d-0400ffff : Critical Array [ComputerSystemElementName] has deasserted.**

The RAID array is no longer in a critical condition.

**Severity**

Info

**Serviceable**

No

**Automatically notify support**

No

**Alert Category**

Critical - Hard Disk drive

**SNMP Trap ID**

5

**CIM Information**

**Prefix:** PLAT ID: 0175

**User Response**

Information only; no action is required.

- **816f050d-0401ffff : Critical Array [ComputerSystemElementName] has deasserted.**

The RAID array is no longer in a critical condition.

**Severity**

Info

**Serviceable**

No

**Automatically notify support**

No

**Alert Category**

Critical - Hard Disk drive

**SNMP Trap ID**

5

**CIM Information**

Prefix: PLAT ID: 0175

**User Response**

Information only; no action is required.

- **816f050d-0402ffff : Critical Array [ComputerSystemElementName] has deasserted.**

The RAID array is no longer in a critical condition.

**Severity**

Info

**Serviceable**

No

**Automatically notify support**

No

**Alert Category**

Critical - Hard Disk drive

**SNMP Trap ID**

5

**CIM Information**

Prefix: PLAT ID: 0175

**User Response**

Information only; no action is required.

- **816f050d-0403ffff : Critical Array [ComputerSystemElementName] has deasserted.**

The RAID array is no longer in a critical condition.

**Severity**

Info

**Serviceable**

No

**Automatically notify support**

No

**Alert Category**

Critical - Hard Disk drive

**SNMP Trap ID**

**CIM Information**

Prefix: PLAT ID: 0175

**User Response**

Information only; no action is required.

- **816f050d-0404ffff : Critical Array [ComputerSystemElementName] has deasserted.**

The RAID array is no longer in a critical condition.

**Severity**

Info

**Serviceable**

No

**Automatically notify support**

No

**Alert Category**

Critical - Hard Disk drive

**SNMP Trap ID**

5

**CIM Information**

Prefix: PLAT ID: 0175

**User Response**

Information only; no action is required.

- **816f050d-0405ffff : Critical Array [ComputerSystemElementName] has deasserted.**

The RAID array is no longer in a critical condition.

**Severity**

Info

**Serviceable**

No

**Automatically notify support**

No

**Alert Category**

Critical - Hard Disk drive

**SNMP Trap ID**

5

**CIM Information**

Prefix: PLAT ID: 0175

**User Response**

Information only; no action is required.

- **816f050d-0406ffff : Critical Array [ComputerSystemElementName] has deasserted.**

The RAID array is no longer in a critical condition.

**Severity**

Info

**Serviceable**

No

**Automatically notify support**

No

**Alert Category**

Critical - Hard Disk drive

**SNMP Trap ID**

5

**CIM Information**

Prefix: PLAT ID: 0175

**User Response**

Information only; no action is required.

- **816f050d-0407ffff : Critical Array [ComputerSystemElementName] has deasserted.**

The RAID array is no longer in a critical condition.

**Severity**

Info

**Serviceable**

No

**Automatically notify support**

No

**Alert Category**

Critical - Hard Disk drive

**SNMP Trap ID**

5

**CIM Information**

Prefix: PLAT ID: 0175

**User Response**

Information only; no action is required.

- **816f0513-2582ffff : A PCI SERR on system [ComputerSystemElementName] has deasserted.**

A PCI System Error (SERR) has recovered. All PCI Error. One of PCI Error.

**Severity**

Info

**Serviceable**

No

**Automatically notify support**

No

**Alert Category**

Critical - Other

**SNMP Trap ID**

50

**CIM Information**

Prefix: PLAT ID: 0235

**User Response**

Information only; no action is required.

**Related links**

- "Finding the UEFI diagnostic code" on page 776

- **816f0607-0301ffff : An SM BIOS Uncorrectable CPU complex error for [ProcessorElementName] has deasserted.**

An SM BIOS uncorrectable CPU complex error has recovered.

**Severity**

Info

**Serviceable**

No

**Automatically notify support**

No

**Alert Category**

Critical - CPU

**SNMP Trap ID**

40

**CIM Information**

Prefix: PLAT ID: 0817

**User Response**

Information only; no action is required.

**Related links**

– “Finding the UEFI diagnostic code” on page 776

- **816f0607-0302ffff : An SM BIOS Uncorrectable CPU complex error for [ProcessorElementName] has deasserted.**

An SM BIOS uncorrectable CPU complex error has recovered.

**Severity**

Info

**Serviceable**

No

**Automatically notify support**

No

**Alert Category**

Critical - CPU

**SNMP Trap ID**

40

**CIM Information**

Prefix: PLAT ID: 0817

**User Response**

Information only; no action is required.

**Related links**

– “Finding the UEFI diagnostic code” on page 776

- **816f0607-0303ffff : An SM BIOS Uncorrectable CPU complex error for [ProcessorElementName] has deasserted.**

An SM BIOS uncorrectable CPU complex error has recovered.

**Severity**

Info

**Serviceable**

No

**Automatically notify support**

No

**Alert Category**

Critical - CPU

**SNMP Trap ID**

40

**CIM Information**

Prefix: PLAT ID: 0817

**User Response**

Information only; no action is required.

**Related links**

– “Finding the UEFI diagnostic code” on page 776

- **816f0607-0304ffff : An SM BIOS Uncorrectable CPU complex error for [ProcessorElementName] has deasserted.**

An SM BIOS uncorrectable CPU complex error has recovered.

**Severity**

Info

**Serviceable**

No

**Automatically notify support**

No

**Alert Category**

Critical - CPU

**SNMP Trap ID**

40

**CIM Information**

Prefix: PLAT ID: 0817

**User Response**

Information only; no action is required.

**Related links**

– “Finding the UEFI diagnostic code” on page 776

- **816f0607-2584ffff : An SM BIOS Uncorrectable CPU complex error for [ProcessorElementName] has deasserted.**

An SM BIOS Uncorrectable CPU complex error has recovered. All CPUs. One of CPUs. Uncorrectable CPU complex error has deasserted. All CPUs. One of CPUs.

**Severity**

Info

**Serviceable**

No

**Automatically notify support**

No

**Alert Category**



Critical - CPU

**SNMP Trap ID**

40

**CIM Information**

**Prefix:** PLAT ID: 0817

**User Response**

Information only; no action is required.

**Related links**

– “Finding the UEFI diagnostic code” on page 776

- **816f060d-0400ffff : Array in system [ComputerSystemElementName] has been restored.**

The failed RAID array has been restored.

**Severity**

Info

**Serviceable**

No

**Automatically notify support**

No

**Alert Category**

Critical - Hard Disk drive

**SNMP Trap ID**

5

**CIM Information**

**Prefix:** PLAT ID: 0177

**User Response**

Information only; no action is required.

- **816f060d-0401ffff : Array in system [ComputerSystemElementName] has been restored.**

The failed RAID array has been restored.

**Severity**

Info

**Serviceable**

No

**Automatically notify support**

No

**Alert Category**

Critical - Hard Disk drive

**SNMP Trap ID**

5

**CIM Information**

**Prefix:** PLAT ID: 0177

**User Response**

Information only; no action is required.

- **816f060d-0402ffff : Array in system [ComputerSystemElementName] has been restored.**

The failed RAID array has been restored.

**Severity**

Info

**Serviceable**

No

**Automatically notify support**

No

**Alert Category**

Critical - Hard Disk drive

**SNMP Trap ID**

5

**CIM Information**

Prefix: PLAT ID: 0177

**User Response**

Information only; no action is required.

- **816f060d-0403ffff : Array in system [ComputerSystemElementName] has been restored.**

The failed RAID array has been restored.

**Severity**

Info

**Serviceable**

No

**Automatically notify support**

No

**Alert Category**

Critical - Hard Disk drive

**SNMP Trap ID**

5

**CIM Information**

Prefix: PLAT ID: 0177

**User Response**

Information only; no action is required.

- **816f060d-0404ffff : Array in system [ComputerSystemElementName] has been restored.**

The failed RAID array has been restored.

**Severity**

Info

**Serviceable**

No

**Automatically notify support**

No

**Alert Category**

Critical - Hard Disk drive

**SNMP Trap ID**

5

**CIM Information**

Prefix: PLAT ID: 0177

**User Response**

Information only; no action is required.

- **816f060d-0405ffff : Array in system [ComputerSystemElementName] has been restored.**

The failed RAID array has been restored.

**Severity**

Info

**Serviceable**

No

**Automatically notify support**

No

**Alert Category**

Critical - Hard Disk drive

**SNMP Trap ID**

5

**CIM Information**

Prefix: PLAT ID: 0177

**User Response**

Information only; no action is required.

- **816f060d-0406ffff : Array in system [ComputerSystemElementName] has been restored.**

The failed RAID array has been restored.

**Severity**

Info

**Serviceable**

No

**Automatically notify support**

No

**Alert Category**

Critical - Hard Disk drive

**SNMP Trap ID**

5

**CIM Information**

Prefix: PLAT ID: 0177

**User Response**

Information only; no action is required.

- **816f060d-0407ffff : Array in system [ComputerSystemElementName] has been restored.**

The failed RAID array has been restored.

**Severity**

Info

**Serviceable**

No

**Automatically notify support**

No

**Alert Category**

Critical - Hard Disk drive

**SNMP Trap ID**

5

**CIM Information**

Prefix: PLAT ID: 0177

**User Response**

Information only; no action is required.

- **816f070c-2001ffff : Configuration error for [PhysicalMemoryElementName] on Subsystem [MemoryElementName]has deasserted.**

A memory DIMM configuration error has recovered.

**Severity**

Info

**Serviceable**

No

**Automatically notify support**

No

**Alert Category**

Critical - Memory

**SNMP Trap ID**

41

**CIM Information**

Prefix: PLAT ID: 0127

**User Response**

Information only; no action is required.

**Related links**

– “Finding the UEFI diagnostic code” on page 776

- **816f070c-2002ffff : Configuration error for [PhysicalMemoryElementName] on Subsystem [MemoryElementName]has deasserted.**

A memory DIMM configuration error has recovered.

**Severity**

Info

**Serviceable**

No

**Automatically notify support**

No

**Alert Category**

Critical - Memory

**SNMP Trap ID**

41

**CIM Information**

Prefix: PLAT ID: 0127

**User Response**

Information only; no action is required.

**Related links**

- “Finding the UEFI diagnostic code” on page 776
- **816f070c-2003ffff : Configuration error for [PhysicalMemoryElementName] on Subsystem [MemoryElementName]has deasserted.**

A memory DIMM configuration error has recovered.

**Severity**

Info

**Serviceable**

No

**Automatically notify support**

No

**Alert Category**

Critical - Memory

**SNMP Trap ID**

41

**CIM Information**

Prefix: PLAT ID: 0127

**User Response**

Information only; no action is required.

**Related links**

- “Finding the UEFI diagnostic code” on page 776
- **816f070c-2004ffff : Configuration error for [PhysicalMemoryElementName] on Subsystem [MemoryElementName]has deasserted.**

A memory DIMM configuration error has recovered.

**Severity**

Info

**Serviceable**

No

**Automatically notify support**

No

**Alert Category**

Critical - Memory

**SNMP Trap ID**

41

**CIM Information**

Prefix: PLAT ID: 0127

**User Response**

Information only; no action is required.

**Related links**

- “Finding the UEFI diagnostic code” on page 776
- **816f070c-2005ffff : Configuration error for [PhysicalMemoryElementName] on Subsystem [MemoryElementName]has deasserted.**

A memory DIMM configuration error has recovered.

**Severity**

Info

**Serviceable**

No

**Automatically notify support**

No

**Alert Category**

Critical - Memory

**SNMP Trap ID**

41

**CIM Information**

Prefix: PLAT ID: 0127

**User Response**

Information only; no action is required.

**Related links**

– “Finding the UEFI diagnostic code” on page 776

- **816f070c-2006ffff : Configuration error for [PhysicalMemoryElementName] on Subsystem [MemoryElementName]has deasserted.**

A memory DIMM configuration error has recovered.

**Severity**

Info

**Serviceable**

No

**Automatically notify support**

No

**Alert Category**

Critical - Memory

**SNMP Trap ID**

41

**CIM Information**

Prefix: PLAT ID: 0127

**User Response**

Information only; no action is required.

**Related links**

– “Finding the UEFI diagnostic code” on page 776

- **816f070c-2007ffff : Configuration error for [PhysicalMemoryElementName] on Subsystem [MemoryElementName]has deasserted.**

A memory DIMM configuration error has recovered.

**Severity**

Info

**Serviceable**

No

**Automatically notify support**

No

**Alert Category**

Critical - Memory

**SNMP Trap ID**

41

**CIM Information****Prefix:** PLAT ID: 0127**User Response**

Information only; no action is required.

**Related links**

- "Finding the UEFI diagnostic code" on page 776
- **816f070c-2008ffff : Configuration error for [PhysicalMemoryElementName] on Subsystem [MemoryElementName]has deasserted.**

A memory DIMM configuration error has recovered.

**Severity**

Info

**Serviceable**

No

**Automatically notify support**

No

**Alert Category**

Critical - Memory

**SNMP Trap ID**

41

**CIM Information****Prefix:** PLAT ID: 0127**User Response**

Information only; no action is required.

**Related links**

- "Finding the UEFI diagnostic code" on page 776
- **816f070c-2009ffff : Configuration error for [PhysicalMemoryElementName] on Subsystem [MemoryElementName]has deasserted.**

A memory DIMM configuration error has recovered.

**Severity**

Info

**Serviceable**

No

**Automatically notify support**

No

**Alert Category**

Critical - Memory

**SNMP Trap ID**

41

**CIM Information****Prefix:** PLAT ID: 0127**User Response**

Information only; no action is required.

**Related links**

– “Finding the UEFI diagnostic code” on page 776

- **816f070c-200affff : Configuration error for [PhysicalMemoryElementName] on Subsystem [MemoryElementName]has deasserted.**

A memory DIMM configuration error has recovered.

**Severity**

Info

**Serviceable**

No

**Automatically notify support**

No

**Alert Category**

Critical - Memory

**SNMP Trap ID**

41

**CIM Information**

Prefix: PLAT ID: 0127

**User Response**

Information only; no action is required.

**Related links**

– “Finding the UEFI diagnostic code” on page 776

- **816f070c-200bffff : Configuration error for [PhysicalMemoryElementName] on Subsystem [MemoryElementName]has deasserted.**

A memory DIMM configuration error has recovered.

**Severity**

Info

**Serviceable**

No

**Automatically notify support**

No

**Alert Category**

Critical - Memory

**SNMP Trap ID**

41

**CIM Information**

Prefix: PLAT ID: 0127

**User Response**

Information only; no action is required.

**Related links**

– “Finding the UEFI diagnostic code” on page 776

- **816f070c-200cffff : Configuration error for [PhysicalMemoryElementName] on Subsystem [MemoryElementName]has deasserted.**

A memory DIMM configuration error has recovered.

**Severity**



Info

**Serviceable**

No

**Automatically notify support**

No

**Alert Category**

Critical - Memory

**SNMP Trap ID**

41

**CIM Information**

**Prefix:** PLAT ID: 0127

**User Response**

Information only; no action is required.

**Related links**

– “Finding the UEFI diagnostic code” on page 776

- **816f070c-200dffff : Configuration error for [PhysicalMemoryElementName] on Subsystem [MemoryElementName]has deasserted.**

A memory DIMM configuration error has recovered.

**Severity**

Info

**Serviceable**

No

**Automatically notify support**

No

**Alert Category**

Critical - Memory

**SNMP Trap ID**

41

**CIM Information**

**Prefix:** PLAT ID: 0127

**User Response**

Information only; no action is required.

**Related links**

– “Finding the UEFI diagnostic code” on page 776

- **816f070c-200effff : Configuration error for [PhysicalMemoryElementName] on Subsystem [MemoryElementName]has deasserted.**

A memory DIMM configuration error has recovered.

**Severity**

Info

**Serviceable**

No

**Automatically notify support**

No

**Alert Category**

Critical - Memory

**SNMP Trap ID**

41

**CIM Information**

**Prefix:** PLAT ID: 0127

**User Response**

Information only; no action is required.

**Related links**

– “Finding the UEFI diagnostic code” on page 776

- **816f070c-200ffff : Configuration error for [PhysicalMemoryElementName] on Subsystem [MemoryElementName]has deasserted.**

A memory DIMM configuration error has recovered.

**Severity**

Info

**Serviceable**

No

**Automatically notify support**

No

**Alert Category**

Critical - Memory

**SNMP Trap ID**

41

**CIM Information**

**Prefix:** PLAT ID: 0127

**User Response**

Information only; no action is required.

**Related links**

– “Finding the UEFI diagnostic code” on page 776

- **816f070c-2010fff : Configuration error for [PhysicalMemoryElementName] on Subsystem [MemoryElementName]has deasserted.**

A memory DIMM configuration error has recovered.

**Severity**

Info

**Serviceable**

No

**Automatically notify support**

No

**Alert Category**

Critical - Memory

**SNMP Trap ID**

41

**CIM Information**

**Prefix:** PLAT ID: 0127

**User Response**

Information only; no action is required.

**Related links**

- "Finding the UEFI diagnostic code" on page 776
- **816f070c-2011ffff : Configuration error for [PhysicalMemoryElementName] on Subsystem [MemoryElementName]has deasserted.**

A memory DIMM configuration error has recovered.

**Severity**

Info

**Serviceable**

No

**Automatically notify support**

No

**Alert Category**

Critical - Memory

**SNMP Trap ID**

41

**CIM Information**

**Prefix:** PLAT ID: 0127

**User Response**

Information only; no action is required.

**Related links**

- "Finding the UEFI diagnostic code" on page 776
- **816f070c-2012ffff : Configuration error for [PhysicalMemoryElementName] on Subsystem [MemoryElementName]has deasserted.**

A memory DIMM configuration error has recovered.

**Severity**

Info

**Serviceable**

No

**Automatically notify support**

No

**Alert Category**

Critical - Memory

**SNMP Trap ID**

41

**CIM Information**

**Prefix:** PLAT ID: 0127

**User Response**

Information only; no action is required.

**Related links**

- "Finding the UEFI diagnostic code" on page 776
- **816f070c-2013ffff : Configuration error for [PhysicalMemoryElementName] on Subsystem [MemoryElementName]has deasserted.**

A memory DIMM configuration error has recovered.

**Severity**

Info

**Serviceable**

No

**Automatically notify support**

No

**Alert Category**

Critical - Memory

**SNMP Trap ID**

41

**CIM Information****Prefix: PLAT ID:** 0127**User Response**

Information only; no action is required.

**Related links**

– “Finding the UEFI diagnostic code” on page 776

- **816f070c-2014ffff : Configuration error for [PhysicalMemoryElementName] on Subsystem [MemoryElementName]has deasserted.**

A memory DIMM configuration error has recovered.

**Severity**

Info

**Serviceable**

No

**Automatically notify support**

No

**Alert Category**

Critical - Memory

**SNMP Trap ID**

41

**CIM Information****Prefix: PLAT ID:** 0127**User Response**

Information only; no action is required.

**Related links**

– “Finding the UEFI diagnostic code” on page 776

- **816f070c-2015ffff : Configuration error for [PhysicalMemoryElementName] on Subsystem [MemoryElementName]has deasserted.**

A memory DIMM configuration error has recovered.

**Severity**

Info

**Serviceable**

No

**Automatically notify support**

No

**Alert Category**

Critical - Memory

**SNMP Trap ID**

41

**CIM Information**

**Prefix:** PLAT ID: 0127

**User Response**

Information only; no action is required.

**Related links**

– “Finding the UEFI diagnostic code” on page 776

- **816f070c-2016ffff : Configuration error for [PhysicalMemoryElementName] on Subsystem [MemoryElementName]has deasserted.**

A memory DIMM configuration error has recovered.

**Severity**

Info

**Serviceable**

No

**Automatically notify support**

No

**Alert Category**

Critical - Memory

**SNMP Trap ID**

41

**CIM Information**

**Prefix:** PLAT ID: 0127

**User Response**

Information only; no action is required.

**Related links**

– “Finding the UEFI diagnostic code” on page 776

- **816f070c-2017ffff : Configuration error for [PhysicalMemoryElementName] on Subsystem [MemoryElementName]has deasserted.**

A memory DIMM configuration error has recovered.

**Severity**

Info

**Serviceable**

No

**Automatically notify support**

No

**Alert Category**

Critical - Memory

**SNMP Trap ID**

41

**CIM Information**

**Prefix:** PLAT ID: 0127

**User Response**

Information only; no action is required.

**Related links**

– “Finding the UEFI diagnostic code” on page 776

- **816f070c-2018ffff : Configuration error for [PhysicalMemoryElementName] on Subsystem [MemoryElementName]has deasserted.**

A memory DIMM configuration error has recovered.

**Severity**

Info

**Serviceable**

No

**Automatically notify support**

No

**Alert Category**

Critical - Memory

**SNMP Trap ID**

41

**CIM Information**

Prefix: PLAT ID: 0127

**User Response**

Information only; no action is required.

**Related links**

– “Finding the UEFI diagnostic code” on page 776

- **816f070c-2019ffff : Configuration error for [PhysicalMemoryElementName] on Subsystem [MemoryElementName]has deasserted.**

A memory DIMM configuration error has recovered.

**Severity**

Info

**Serviceable**

No

**Automatically notify support**

No

**Alert Category**

Critical - Memory

**SNMP Trap ID**

41

**CIM Information**

Prefix: PLAT ID: 0127

**User Response**

Information only; no action is required.

**Related links**

– “Finding the UEFI diagnostic code” on page 776

- **816f070c-201affff : Configuration error for [PhysicalMemoryElementName] on Subsystem [MemoryElementName]has deasserted.**

A memory DIMM configuration error has recovered.

**Severity**

Info

**Serviceable**

No

**Automatically notify support**

No

**Alert Category**

Critical - Memory

**SNMP Trap ID**

41

**CIM Information**

**Prefix:** PLAT ID: 0127

**User Response**

Information only; no action is required.

**Related links**

– “Finding the UEFI diagnostic code” on page 776

- **816f070c-201bfff : Configuration error for [PhysicalMemoryElementName] on Subsystem [MemoryElementName]has deasserted.**

A memory DIMM configuration error has recovered.

**Severity**

Info

**Serviceable**

No

**Automatically notify support**

No

**Alert Category**

Critical - Memory

**SNMP Trap ID**

41

**CIM Information**

**Prefix:** PLAT ID: 0127

**User Response**

Information only; no action is required.

**Related links**

– “Finding the UEFI diagnostic code” on page 776

- **816f070c-201cfff : Configuration error for [PhysicalMemoryElementName] on Subsystem [MemoryElementName]has deasserted.**

A memory DIMM configuration error has recovered.

**Severity**

Info

**Serviceable**

No

**Automatically notify support**

No

**Alert Category**

Critical - Memory

**SNMP Trap ID**

41

**CIM Information**

Prefix: PLAT ID: 0127

**User Response**

Information only; no action is required.

**Related links**

– “Finding the UEFI diagnostic code” on page 776

- **816f070c-201dffff : Configuration error for [PhysicalMemoryElementName] on Subsystem [MemoryElementName]has deasserted.**

A memory DIMM configuration error has recovered.

**Severity**

Info

**Serviceable**

No

**Automatically notify support**

No

**Alert Category**

Critical - Memory

**SNMP Trap ID**

41

**CIM Information**

Prefix: PLAT ID: 0127

**User Response**

Information only; no action is required.

**Related links**

– “Finding the UEFI diagnostic code” on page 776

- **816f070c-201effff : Configuration error for [PhysicalMemoryElementName] on Subsystem [MemoryElementName]has deasserted.**

A memory DIMM configuration error has recovered.

**Severity**

Info

**Serviceable**

No

**Automatically notify support**

No

**Alert Category**

Critical - Memory

**SNMP Trap ID**

41



**CIM Information**

Prefix: PLAT ID: 0127

**User Response**

Information only; no action is required.

**Related links**

- "Finding the UEFI diagnostic code" on page 776
- **816f070c-201ffff : Configuration error for [PhysicalMemoryElementName] on Subsystem [MemoryElementName]has deasserted.**

A memory DIMM configuration error has recovered.

**Severity**

Info

**Serviceable**

No

**Automatically notify support**

No

**Alert Category**

Critical - Memory

**SNMP Trap ID**

41

**CIM Information**

Prefix: PLAT ID: 0127

**User Response**

Information only; no action is required.

**Related links**

- "Finding the UEFI diagnostic code" on page 776
- **816f070c-2020ffff : Configuration error for [PhysicalMemoryElementName] on Subsystem [MemoryElementName]has deasserted.**

A memory DIMM configuration error has recovered.

**Severity**

Info

**Serviceable**

No

**Automatically notify support**

No

**Alert Category**

Critical - Memory

**SNMP Trap ID**

41

**CIM Information**

Prefix: PLAT ID: 0127

**User Response**

Information only; no action is required.

**Related links**

- "Finding the UEFI diagnostic code" on page 776

- **816f070c-2021ffff : Configuration error for [PhysicalMemoryElementName] on Subsystem [MemoryElementName]has deasserted.**

A memory DIMM configuration error has recovered.

**Severity**

Info

**Serviceable**

No

**Automatically notify support**

No

**Alert Category**

Critical - Memory

**SNMP Trap ID**

41

**CIM Information**

Prefix: PLAT ID: 0127

**User Response**

Information only; no action is required.

**Related links**

– “Finding the UEFI diagnostic code” on page 776

- **816f070c-2022ffff : Configuration error for [PhysicalMemoryElementName] on Subsystem [MemoryElementName]has deasserted.**

A memory DIMM configuration error has recovered.

**Severity**

Info

**Serviceable**

No

**Automatically notify support**

No

**Alert Category**

Critical - Memory

**SNMP Trap ID**

41

**CIM Information**

Prefix: PLAT ID: 0127

**User Response**

Information only; no action is required.

**Related links**

– “Finding the UEFI diagnostic code” on page 776

- **816f070c-2023ffff : Configuration error for [PhysicalMemoryElementName] on Subsystem [MemoryElementName]has deasserted.**

A memory DIMM configuration error has recovered.

**Severity**

Info

**Serviceable**

No

**Automatically notify support**

No

**Alert Category**

Critical - Memory

**SNMP Trap ID**

41

**CIM Information**

Prefix: PLAT ID: 0127

**User Response**

Information only; no action is required.

**Related links**

– “Finding the UEFI diagnostic code” on page 776

- **816f070c-2024ffff : Configuration error for [PhysicalMemoryElementName] on Subsystem [MemoryElementName]has deasserted.**

A memory DIMM configuration error has recovered.

**Severity**

Info

**Serviceable**

No

**Automatically notify support**

No

**Alert Category**

Critical - Memory

**SNMP Trap ID**

41

**CIM Information**

Prefix: PLAT ID: 0127

**User Response**

Information only; no action is required.

**Related links**

– “Finding the UEFI diagnostic code” on page 776

- **816f070c-2025ffff : Configuration error for [PhysicalMemoryElementName] on Subsystem [MemoryElementName]has deasserted.**

A memory DIMM configuration error has recovered.

**Severity**

Info

**Serviceable**

No

**Automatically notify support**

No

**Alert Category**

Critical - Memory

**SNMP Trap ID**

41

**CIM Information**

Prefix: PLAT ID: 0127

**User Response**

Information only; no action is required.

**Related links**

– “Finding the UEFI diagnostic code” on page 776

- **816f070c-2026ffff : Configuration error for [PhysicalMemoryElementName] on Subsystem [MemoryElementName]has deasserted.**

A memory DIMM configuration error has recovered.

**Severity**

Info

**Serviceable**

No

**Automatically notify support**

No

**Alert Category**

Critical - Memory

**SNMP Trap ID**

41

**CIM Information**

Prefix: PLAT ID: 0127

**User Response**

Information only; no action is required.

**Related links**

– “Finding the UEFI diagnostic code” on page 776

- **816f070c-2027ffff : Configuration error for [PhysicalMemoryElementName] on Subsystem [MemoryElementName]has deasserted.**

A memory DIMM configuration error has recovered.

**Severity**

Info

**Serviceable**

No

**Automatically notify support**

No

**Alert Category**

Critical - Memory

**SNMP Trap ID**

41

**CIM Information**

Prefix: PLAT ID: 0127

**User Response**

Information only; no action is required.

**Related links**

- "Finding the UEFI diagnostic code" on page 776
- **816f070c-2028ffff : Configuration error for [PhysicalMemoryElementName] on Subsystem [MemoryElementName]has deasserted.**

A memory DIMM configuration error has recovered.

**Severity**

Info

**Serviceable**

No

**Automatically notify support**

No

**Alert Category**

Critical - Memory

**SNMP Trap ID**

41

**CIM Information**

Prefix: PLAT ID: 0127

**User Response**

Information only; no action is required.

**Related links**

- "Finding the UEFI diagnostic code" on page 776
- **816f070c-2029ffff : Configuration error for [PhysicalMemoryElementName] on Subsystem [MemoryElementName]has deasserted.**

A memory DIMM configuration error has recovered.

**Severity**

Info

**Serviceable**

No

**Automatically notify support**

No

**Alert Category**

Critical - Memory

**SNMP Trap ID**

41

**CIM Information**

Prefix: PLAT ID: 0127

**User Response**

Information only; no action is required.

**Related links**

- "Finding the UEFI diagnostic code" on page 776
- **816f070c-202affff : Configuration error for [PhysicalMemoryElementName] on Subsystem [MemoryElementName]has deasserted.**

A memory DIMM configuration error has recovered.

**Severity**

Info

**Serviceable**

No

**Automatically notify support**

No

**Alert Category**

Critical - Memory

**SNMP Trap ID**

41

**CIM Information**

Prefix: PLAT ID: 0127

**User Response**

Information only; no action is required.

**Related links**

– “Finding the UEFI diagnostic code” on page 776

- **816f070c-202bffff : Configuration error for [PhysicalMemoryElementName] on Subsystem [MemoryElementName]has deasserted.**

A memory DIMM configuration error has recovered.

**Severity**

Info

**Serviceable**

No

**Automatically notify support**

No

**Alert Category**

Critical - Memory

**SNMP Trap ID**

41

**CIM Information**

Prefix: PLAT ID: 0127

**User Response**

Information only; no action is required.

**Related links**

– “Finding the UEFI diagnostic code” on page 776

- **816f070c-202cffff : Configuration error for [PhysicalMemoryElementName] on Subsystem [MemoryElementName]has deasserted.**

A memory DIMM configuration error has recovered.

**Severity**

Info

**Serviceable**

No

**Automatically notify support**

No

**Alert Category**

Critical - Memory

**SNMP Trap ID**

41

**CIM Information**

**Prefix:** PLAT ID: 0127

**User Response**

Information only; no action is required.

**Related links**

- "Finding the UEFI diagnostic code" on page 776
- **816f070c-202dfff : Configuration error for [PhysicalMemoryElementName] on Subsystem [MemoryElementName]has deasserted.**

A memory DIMM configuration error has recovered.

**Severity**

Info

**Serviceable**

No

**Automatically notify support**

No

**Alert Category**

Critical - Memory

**SNMP Trap ID**

41

**CIM Information**

**Prefix:** PLAT ID: 0127

**User Response**

Information only; no action is required.

**Related links**

- "Finding the UEFI diagnostic code" on page 776
- **816f070c-202efff : Configuration error for [PhysicalMemoryElementName] on Subsystem [MemoryElementName]has deasserted.**

A memory DIMM configuration error has recovered.

**Severity**

Info

**Serviceable**

No

**Automatically notify support**

No

**Alert Category**

Critical - Memory

**SNMP Trap ID**

41

**CIM Information**

**Prefix:** PLAT ID: 0127

**User Response**

Information only; no action is required.

**Related links**

– “Finding the UEFI diagnostic code” on page 776

- **816f070c-202ffff : Configuration error for [PhysicalMemoryElementName] on Subsystem [MemoryElementName]has deasserted.**

A memory DIMM configuration error has recovered.

**Severity**

Info

**Serviceable**

No

**Automatically notify support**

No

**Alert Category**

Critical - Memory

**SNMP Trap ID**

41

**CIM Information**

Prefix: PLAT ID: 0127

**User Response**

Information only; no action is required.

**Related links**

– “Finding the UEFI diagnostic code” on page 776

- **816f070c-2030fff : Configuration error for [PhysicalMemoryElementName] on Subsystem [MemoryElementName]has deasserted.**

A memory DIMM configuration error has recovered.

**Severity**

Info

**Serviceable**

No

**Automatically notify support**

No

**Alert Category**

Critical - Memory

**SNMP Trap ID**

41

**CIM Information**

Prefix: PLAT ID: 0127

**User Response**

Information only; no action is required.

**Related links**

– “Finding the UEFI diagnostic code” on page 776

- **816f070c-2581fff : Configuration error for [PhysicalMemoryElementName] on Subsystem [MemoryElementName]has deasserted.**

A memory DIMM configuration error has recovered. All DIMMs. One of the DIMMs.



**Severity**

Info

**Serviceable**

No

**Automatically notify support**

No

**Alert Category**

Critical - Memory

**SNMP Trap ID**

41

**CIM Information**

**Prefix:** PLAT ID: 0127

**User Response**

Information only; no action is required.

**Related links**

– “Finding the UEFI diagnostic code” on page 776

- **816f070d-0400ffff : Rebuild completed for Array in system [ComputerSystemElementName].**

The rebuild of the RAID array has completed.

**Severity**

Info

**Serviceable**

No

**Automatically notify support**

No

**Alert Category**

System - Other

**SNMP Trap ID****CIM Information**

**Prefix:** PLAT ID: 0179

**User Response**

Information only; no action is required.

- **816f070d-0401ffff : Rebuild completed for Array in system [ComputerSystemElementName].**

The rebuild of the RAID array has completed.

**Severity**

Info

**Serviceable**

No

**Automatically notify support**

No

**Alert Category**

System - Other

**SNMP Trap ID**

**CIM Information**

Prefix: PLAT ID: 0179

**User Response**

Information only; no action is required.

- **816f070d-0402ffff : Rebuild completed for Array in system [ComputerSystemElementName].**

The rebuild of the RAID array has completed.

**Severity**

Info

**Serviceable**

No

**Automatically notify support**

No

**Alert Category**

System - Other

**SNMP Trap ID****CIM Information**

Prefix: PLAT ID: 0179

**User Response**

Information only; no action is required.

- **816f070d-0403ffff : Rebuild completed for Array in system [ComputerSystemElementName].**

The rebuild of the RAID array has completed.

**Severity**

Info

**Serviceable**

No

**Automatically notify support**

No

**Alert Category**

System - Other

**SNMP Trap ID****CIM Information**

Prefix: PLAT ID: 0179

**User Response**

Information only; no action is required.

- **816f070d-0404ffff : Rebuild completed for Array in system [ComputerSystemElementName].**

The rebuild of the RAID array has completed.

**Severity**

Info

**Serviceable**

No

**Automatically notify support**

No

**Alert Category**

System - Other

**SNMP Trap ID**

**CIM Information**

Prefix: PLAT ID: 0179

**User Response**

Information only; no action is required.

- **816f070d-0405ffff : Rebuild completed for Array in system [ComputerSystemElementName].**

The rebuild of the RAID array has completed.

**Severity**

Info

**Serviceable**

No

**Automatically notify support**

No

**Alert Category**

System - Other

**SNMP Trap ID**

**CIM Information**

Prefix: PLAT ID: 0179

**User Response**

Information only; no action is required.

- **816f070d-0406ffff : Rebuild completed for Array in system [ComputerSystemElementName].**

The rebuild of the RAID array has completed.

**Severity**

Info

**Serviceable**

No

**Automatically notify support**

No

**Alert Category**

System - Other

**SNMP Trap ID**

**CIM Information**

Prefix: PLAT ID: 0179

**User Response**

Information only; no action is required.

- **816f070d-0407ffff : Rebuild completed for Array in system [ComputerSystemElementName].**

The rebuild of the RAID array has completed.

**Severity**

Info

**Serviceable**

No

**Automatically notify support**

No

**Alert Category**

System - Other

**SNMP Trap ID****CIM Information**

Prefix: PLAT ID: 0179

**User Response**

Information only; no action is required.

- **816f0807-0301ffff : [ProcessorElementName] has been Enabled.**

A Processor has been Enabled.

**Severity**

Info

**Serviceable**

No

**Automatically notify support**

No

**Alert Category**

System - Other

**SNMP Trap ID****CIM Information**

Prefix: PLAT ID: 0060

**User Response**

Information only; no action is required.

**Related links**

– “Finding the UEFI diagnostic code” on page 776

- **816f0807-0302ffff : [ProcessorElementName] has been Enabled.**

A Processor has been Enabled.

**Severity**

Info

**Serviceable**

No

**Automatically notify support**

No

**Alert Category**

System - Other

**SNMP Trap ID**

**CIM Information**

Prefix: PLAT ID: 0060

**User Response**

Information only; no action is required.

**Related links**

– “Finding the UEFI diagnostic code” on page 776

- **816f0807-0303ffff : [ProcessorElementName] has been Enabled.**

A Processor has been Enabled.

**Severity**

Info

**Serviceable**

No

**Automatically notify support**

No

**Alert Category**

System - Other

**SNMP Trap ID****CIM Information**

Prefix: PLAT ID: 0060

**User Response**

Information only; no action is required.

**Related links**

– “Finding the UEFI diagnostic code” on page 776

- **816f0807-0304ffff : [ProcessorElementName] has been Enabled.**

A Processor has been Enabled.

**Severity**

Info

**Serviceable**

No

**Automatically notify support**

No

**Alert Category**

System - Other

**SNMP Trap ID****CIM Information**

Prefix: PLAT ID: 0060

**User Response**

Information only; no action is required.

**Related links**

– “Finding the UEFI diagnostic code” on page 776

- **816f0807-2584ffff : [ProcessorElementName] has been Enabled.**

A processor has been enabled. All CPUs. One of CPUs.

**Severity**

Info

**Serviceable**

No

**Automatically notify support**

No

**Alert Category**

System - Other

**SNMP Trap ID****CIM Information**

Prefix: PLAT ID: 0060

**User Response**

Information only; no action is required.

**Related links**

– “Finding the UEFI diagnostic code” on page 776

- **816f0813-2581ffff : Bus [SensorElementName] has recovered from an Uncorrectable Bus Error.**  
the system has recovered from a bus uncorrectable error. DIMMs.

**Severity**

Info

**Serviceable**

No

**Automatically notify support**

No

**Alert Category**

Critical - Other

**SNMP Trap ID**

50

**CIM Information**

Prefix: PLAT ID: 0241

**User Response**

Information only; no action is required.

**Related links**

– “Finding the UEFI diagnostic code” on page 776

- **816f0813-2584ffff : Bus [SensorElementName] has recovered from an Uncorrectable Bus Error.**  
A Bus Uncorrectable Error has recovered. CPUs.

**Severity**

Info

**Serviceable**

No

**Automatically notify support**

No

**Alert Category**

Critical - Other

**SNMP Trap ID**

50

**CIM Information****Prefix:** PLAT ID: 0241**User Response**

Information only; no action is required.

**Related links**

– “Finding the UEFI diagnostic code” on page 776

- **816f090c-2001ffff : [PhysicalMemoryElementName] on Subsystem [MemoryElementName] is no longer Throttled.**

Memory DIMM throttling has been turned off.

**Severity**

Info

**Serviceable**

No

**Automatically notify support**

No

**Alert Category**

System - Other

**SNMP Trap ID****CIM Information****Prefix:** PLAT ID: 0143**User Response**

Information only; no action is required.

- **816f090c-2002ffff : [PhysicalMemoryElementName] on Subsystem [MemoryElementName] is no longer Throttled.**

Memory DIMM throttling has been turned off.

**Severity**

Info

**Serviceable**

No

**Automatically notify support**

No

**Alert Category**

System - Other

**SNMP Trap ID****CIM Information****Prefix:** PLAT ID: 0143**User Response**

Information only; no action is required.

- **816f090c-2003ffff : [PhysicalMemoryElementName] on Subsystem [MemoryElementName] is no longer Throttled.**

Memory DIMM throttling has been turned off.

**Severity**

Info

**Serviceable**

No

**Automatically notify support**

No

**Alert Category**

System - Other

**SNMP Trap ID**

**CIM Information**

Prefix: PLAT ID: 0143

**User Response**

Information only; no action is required.

- **816f090c-2004ffff : [PhysicalMemoryElementName] on Subsystem [MemoryElementName] is no longer Throttled.**

Memory DIMM throttling has been turned off.

**Severity**

Info

**Serviceable**

No

**Automatically notify support**

No

**Alert Category**

System - Other

**SNMP Trap ID**

**CIM Information**

Prefix: PLAT ID: 0143

**User Response**

Information only; no action is required.

- **816f090c-2005ffff : [PhysicalMemoryElementName] on Subsystem [MemoryElementName] is no longer Throttled.**

Memory DIMM throttling has been turned off.

**Severity**

Info

**Serviceable**

No

**Automatically notify support**

No

**Alert Category**

System - Other



## SNMP Trap ID

### CIM Information

Prefix: PLAT ID: 0143

### User Response

Information only; no action is required.

- **816f090c-2006ffff : [PhysicalMemoryElementName] on Subsystem [MemoryElementName] is no longer Throttled.**

Memory DIMM throttling has been turned off.

### Severity

Info

### Serviceable

No

### Automatically notify support

No

### Alert Category

System - Other

## SNMP Trap ID

### CIM Information

Prefix: PLAT ID: 0143

### User Response

Information only; no action is required.

- **816f090c-2007ffff : [PhysicalMemoryElementName] on Subsystem [MemoryElementName] is no longer Throttled.**

Memory DIMM throttling has been turned off.

### Severity

Info

### Serviceable

No

### Automatically notify support

No

### Alert Category

System - Other

## SNMP Trap ID

### CIM Information

Prefix: PLAT ID: 0143

### User Response

Information only; no action is required.

- **816f090c-2008ffff : [PhysicalMemoryElementName] on Subsystem [MemoryElementName] is no longer Throttled.**

Memory DIMM throttling has been turned off.

### Severity

Info

**Serviceable**

No

**Automatically notify support**

No

**Alert Category**

System - Other

**SNMP Trap ID**

**CIM Information**

Prefix: PLAT ID: 0143

**User Response**

Information only; no action is required.

- **816f090c-2009ffff : [PhysicalMemoryElementName] on Subsystem [MemoryElementName] is no longer Throttled.**

Memory DIMM throttling has been turned off.

**Severity**

Info

**Serviceable**

No

**Automatically notify support**

No

**Alert Category**

System - Other

**SNMP Trap ID**

**CIM Information**

Prefix: PLAT ID: 0143

**User Response**

Information only; no action is required.

- **816f090c-200affff : [PhysicalMemoryElementName] on Subsystem [MemoryElementName] is no longer Throttled.**

Memory DIMM throttling has been turned off.

**Severity**

Info

**Serviceable**

No

**Automatically notify support**

No

**Alert Category**

System - Other

**SNMP Trap ID**

**CIM Information**

**Prefix:** PLAT ID: 0143

**User Response**

Information only; no action is required.

- **816f090c-200bffff : [PhysicalMemoryElementName] on Subsystem [MemoryElementName] is no longer Throttled.**

Memory DIMM throttling has been turned off.

**Severity**

Info

**Serviceable**

No

**Automatically notify support**

No

**Alert Category**

System - Other

**SNMP Trap ID**

**CIM Information**

**Prefix:** PLAT ID: 0143

**User Response**

Information only; no action is required.

- **816f090c-200cffff : [PhysicalMemoryElementName] on Subsystem [MemoryElementName] is no longer Throttled.**

Memory DIMM throttling has been turned off.

**Severity**

Info

**Serviceable**

No

**Automatically notify support**

No

**Alert Category**

System - Other

**SNMP Trap ID**

**CIM Information**

**Prefix:** PLAT ID: 0143

**User Response**

Information only; no action is required.

- **816f090c-200dffff : [PhysicalMemoryElementName] on Subsystem [MemoryElementName] is no longer Throttled.**

Memory DIMM throttling has been turned off.

**Severity**

Info

**Serviceable**

No

**Automatically notify support**

No

**Alert Category**

System - Other

**SNMP Trap ID****CIM Information**

Prefix: PLAT ID: 0143

**User Response**

Information only; no action is required.

- **816f090c-200effff : [PhysicalMemoryElementName] on Subsystem [MemoryElementName] is no longer Throttled.**

Memory DIMM throttling has been turned off.

**Severity**

Info

**Serviceable**

No

**Automatically notify support**

No

**Alert Category**

System - Other

**SNMP Trap ID****CIM Information**

Prefix: PLAT ID: 0143

**User Response**

Information only; no action is required.

- **816f090c-200fffff : [PhysicalMemoryElementName] on Subsystem [MemoryElementName] is no longer Throttled.**

Memory DIMM throttling has been turned off.

**Severity**

Info

**Serviceable**

No

**Automatically notify support**

No

**Alert Category**

System - Other

**SNMP Trap ID****CIM Information**

Prefix: PLAT ID: 0143

**User Response**

Information only; no action is required.

- **816f090c-2010ffff : [PhysicalMemoryElementName] on Subsystem [MemoryElementName] is no longer Throttled.**

Memory DIMM throttling has been turned off.

**Severity**

Info

**Serviceable**

No

**Automatically notify support**

No

**Alert Category**

System - Other

**SNMP Trap ID**

**CIM Information**

Prefix: PLAT ID: 0143

**User Response**

Information only; no action is required.

- **816f090c-2011ffff : [PhysicalMemoryElementName] on Subsystem [MemoryElementName] is no longer Throttled.**

Memory DIMM throttling has been turned off.

**Severity**

Info

**Serviceable**

No

**Automatically notify support**

No

**Alert Category**

System - Other

**SNMP Trap ID**

**CIM Information**

Prefix: PLAT ID: 0143

**User Response**

Information only; no action is required.

- **816f090c-2012ffff : [PhysicalMemoryElementName] on Subsystem [MemoryElementName] is no longer Throttled.**

Memory DIMM throttling has been turned off.

**Severity**

Info

**Serviceable**

No

**Automatically notify support**

No

**Alert Category**  
System - Other

**SNMP Trap ID**

**CIM Information**  
Prefix: PLAT ID: 0143

**User Response**  
Information only; no action is required.

- **816f090c-2013ffff : [PhysicalMemoryElementName] on Subsystem [MemoryElementName] is no longer Throttled.**

Memory DIMM throttling has been turned off.

**Severity**  
Info

**Serviceable**  
No

**Automatically notify support**  
No

**Alert Category**  
System - Other

**SNMP Trap ID**

**CIM Information**  
Prefix: PLAT ID: 0143

**User Response**  
Information only; no action is required.

- **816f090c-2014ffff : [PhysicalMemoryElementName] on Subsystem [MemoryElementName] is no longer Throttled.**

Memory DIMM throttling has been turned off.

**Severity**  
Info

**Serviceable**  
No

**Automatically notify support**  
No

**Alert Category**  
System - Other

**SNMP Trap ID**

**CIM Information**  
Prefix: PLAT ID: 0143

**User Response**  
Information only; no action is required.

- **816f090c-2015ffff : [PhysicalMemoryElementName] on Subsystem [MemoryElementName] is no longer Throttled.**

Memory DIMM throttling has been turned off.

**Severity**

Info

**Serviceable**

No

**Automatically notify support**

No

**Alert Category**

System - Other

**SNMP Trap ID**

**CIM Information**

Prefix: PLAT ID: 0143

**User Response**

Information only; no action is required.

- **816f090c-2016ffff : [PhysicalMemoryElementName] on Subsystem [MemoryElementName] is no longer Throttled.**

Memory DIMM throttling has been turned off.

**Severity**

Info

**Serviceable**

No

**Automatically notify support**

No

**Alert Category**

System - Other

**SNMP Trap ID**

**CIM Information**

Prefix: PLAT ID: 0143

**User Response**

Information only; no action is required.

- **816f090c-2017ffff : [PhysicalMemoryElementName] on Subsystem [MemoryElementName] is no longer Throttled.**

Memory DIMM throttling has been turned off.

**Severity**

Info

**Serviceable**

No

**Automatically notify support**

No

**Alert Category**

System - Other

## SNMP Trap ID

### CIM Information

Prefix: PLAT ID: 0143

### User Response

Information only; no action is required.

- **816f090c-2018ffff : [PhysicalMemoryElementName] on Subsystem [MemoryElementName] is no longer Throttled.**

Memory DIMM throttling has been turned off.

### Severity

Info

### Serviceable

No

### Automatically notify support

No

### Alert Category

System - Other

## SNMP Trap ID

### CIM Information

Prefix: PLAT ID: 0143

### User Response

Information only; no action is required.

- **816f090c-2019ffff : [PhysicalMemoryElementName] on Subsystem [MemoryElementName] is no longer Throttled.**

Memory DIMM throttling has been turned off.

### Severity

Info

### Serviceable

No

### Automatically notify support

No

### Alert Category

System - Other

## SNMP Trap ID

### CIM Information

Prefix: PLAT ID: 0143

### User Response

Information only; no action is required.

- **816f090c-201affff : [PhysicalMemoryElementName] on Subsystem [MemoryElementName] is no longer Throttled.**

Memory DIMM throttling has been turned off.

### Severity



Info

**Serviceable**

No

**Automatically notify support**

No

**Alert Category**

System - Other

**SNMP Trap ID**

**CIM Information**

Prefix: PLAT ID: 0143

**User Response**

Information only; no action is required.

- **816f090c-201bffff : [PhysicalMemoryElementName] on Subsystem [MemoryElementName] is no longer Throttled.**

Memory DIMM throttling has been turned off.

**Severity**

Info

**Serviceable**

No

**Automatically notify support**

No

**Alert Category**

System - Other

**SNMP Trap ID**

**CIM Information**

Prefix: PLAT ID: 0143

**User Response**

Information only; no action is required.

- **816f090c-201cffff : [PhysicalMemoryElementName] on Subsystem [MemoryElementName] is no longer Throttled.**

Memory DIMM throttling has been turned off.

**Severity**

Info

**Serviceable**

No

**Automatically notify support**

No

**Alert Category**

System - Other

**SNMP Trap ID**

**CIM Information**

**Prefix: PLAT ID:** 0143

**User Response**

Information only; no action is required.

- **816f090c-201dffff : [PhysicalMemoryElementName] on Subsystem [MemoryElementName] is no longer Throttled.**

Memory DIMM throttling has been turned off.

**Severity**

Info

**Serviceable**

No

**Automatically notify support**

No

**Alert Category**

System - Other

**SNMP Trap ID**

**CIM Information**

**Prefix: PLAT ID:** 0143

**User Response**

Information only; no action is required.

- **816f090c-201effff : [PhysicalMemoryElementName] on Subsystem [MemoryElementName] is no longer Throttled.**

Memory DIMM throttling has been turned off.

**Severity**

Info

**Serviceable**

No

**Automatically notify support**

No

**Alert Category**

System - Other

**SNMP Trap ID**

**CIM Information**

**Prefix: PLAT ID:** 0143

**User Response**

Information only; no action is required.

- **816f090c-201fffff : [PhysicalMemoryElementName] on Subsystem [MemoryElementName] is no longer Throttled.**

Memory DIMM throttling has been turned off.

**Severity**

Info

**Serviceable**

No

**Automatically notify support**

No

**Alert Category**

System - Other

**SNMP Trap ID**

**CIM Information**

Prefix: PLAT ID: 0143

**User Response**

Information only; no action is required.

- **816f090c-2020ffff : [PhysicalMemoryElementName] on Subsystem [MemoryElementName] is no longer Throttled.**

Memory DIMM throttling has been turned off.

**Severity**

Info

**Serviceable**

No

**Automatically notify support**

No

**Alert Category**

System - Other

**SNMP Trap ID**

**CIM Information**

Prefix: PLAT ID: 0143

**User Response**

Information only; no action is required.

- **816f090c-2021ffff : [PhysicalMemoryElementName] on Subsystem [MemoryElementName] is no longer Throttled.**

Memory DIMM throttling has been turned off.

**Severity**

Info

**Serviceable**

No

**Automatically notify support**

No

**Alert Category**

System - Other

**SNMP Trap ID**

**CIM Information**

Prefix: PLAT ID: 0143

**User Response**

Information only; no action is required.

- **816f090c-2022ffff : [PhysicalMemoryElementName] on Subsystem [MemoryElementName] is no longer Throttled.**

Memory DIMM throttling has been turned off.

**Severity**

Info

**Serviceable**

No

**Automatically notify support**

No

**Alert Category**

System - Other

**SNMP Trap ID**

**CIM Information**

Prefix: PLAT ID: 0143

**User Response**

Information only; no action is required.

- **816f090c-2023ffff : [PhysicalMemoryElementName] on Subsystem [MemoryElementName] is no longer Throttled.**

Memory DIMM throttling has been turned off.

**Severity**

Info

**Serviceable**

No

**Automatically notify support**

No

**Alert Category**

System - Other

**SNMP Trap ID**

**CIM Information**

Prefix: PLAT ID: 0143

**User Response**

Information only; no action is required.

- **816f090c-2024ffff : [PhysicalMemoryElementName] on Subsystem [MemoryElementName] is no longer Throttled.**

Memory DIMM throttling has been turned off.

**Severity**

Info

**Serviceable**

No

**Automatically notify support**

No

**Alert Category**  
System - Other

**SNMP Trap ID**

**CIM Information**  
Prefix: PLAT ID: 0143

**User Response**  
Information only; no action is required.

- **816f090c-2025ffff : [PhysicalMemoryElementName] on Subsystem [MemoryElementName] is no longer Throttled.**

Memory DIMM throttling has been turned off.

**Severity**  
Info

**Serviceable**  
No

**Automatically notify support**  
No

**Alert Category**  
System - Other

**SNMP Trap ID**

**CIM Information**  
Prefix: PLAT ID: 0143

**User Response**  
Information only; no action is required.

- **816f090c-2026ffff : [PhysicalMemoryElementName] on Subsystem [MemoryElementName] is no longer Throttled.**

Memory DIMM throttling has been turned off.

**Severity**  
Info

**Serviceable**  
No

**Automatically notify support**  
No

**Alert Category**  
System - Other

**SNMP Trap ID**

**CIM Information**  
Prefix: PLAT ID: 0143

**User Response**  
Information only; no action is required.

- **816f090c-2027ffff : [PhysicalMemoryElementName] on Subsystem [MemoryElementName] is no longer Throttled.**

Memory DIMM throttling has been turned off.

**Severity**

Info

**Serviceable**

No

**Automatically notify support**

No

**Alert Category**

System - Other

**SNMP Trap ID**

**CIM Information**

Prefix: PLAT ID: 0143

**User Response**

Information only; no action is required.

- **816f090c-2028ffff : [PhysicalMemoryElementName] on Subsystem [MemoryElementName] is no longer Throttled.**

Memory DIMM throttling has been turned off.

**Severity**

Info

**Serviceable**

No

**Automatically notify support**

No

**Alert Category**

System - Other

**SNMP Trap ID**

**CIM Information**

Prefix: PLAT ID: 0143

**User Response**

Information only; no action is required.

- **816f090c-2029ffff : [PhysicalMemoryElementName] on Subsystem [MemoryElementName] is no longer Throttled.**

Memory DIMM throttling has been turned off.

**Severity**

Info

**Serviceable**

No

**Automatically notify support**

No

**Alert Category**

System - Other

## SNMP Trap ID

### CIM Information

Prefix: PLAT ID: 0143

### User Response

Information only; no action is required.

- **816f090c-202affff : [PhysicalMemoryElementName] on Subsystem [MemoryElementName] is no longer Throttled.**

Memory DIMM throttling has been turned off.

### Severity

Info

### Serviceable

No

### Automatically notify support

No

### Alert Category

System - Other

## SNMP Trap ID

### CIM Information

Prefix: PLAT ID: 0143

### User Response

Information only; no action is required.

- **816f090c-202bffff : [PhysicalMemoryElementName] on Subsystem [MemoryElementName] is no longer Throttled.**

Memory DIMM throttling has been turned off.

### Severity

Info

### Serviceable

No

### Automatically notify support

No

### Alert Category

System - Other

## SNMP Trap ID

### CIM Information

Prefix: PLAT ID: 0143

### User Response

Information only; no action is required.

- **816f090c-202cffff : [PhysicalMemoryElementName] on Subsystem [MemoryElementName] is no longer Throttled.**

Memory DIMM throttling has been turned off.

### Severity

Info

**Serviceable**

No

**Automatically notify support**

No

**Alert Category**

System - Other

**SNMP Trap ID**

**CIM Information**

Prefix: PLAT ID: 0143

**User Response**

Information only; no action is required.

- **816f090c-202dffff : [PhysicalMemoryElementName] on Subsystem [MemoryElementName] is no longer Throttled.**

Memory DIMM throttling has been turned off.

**Severity**

Info

**Serviceable**

No

**Automatically notify support**

No

**Alert Category**

System - Other

**SNMP Trap ID**

**CIM Information**

Prefix: PLAT ID: 0143

**User Response**

Information only; no action is required.

- **816f090c-202effff : [PhysicalMemoryElementName] on Subsystem [MemoryElementName] is no longer Throttled.**

Memory DIMM throttling has been turned off.

**Severity**

Info

**Serviceable**

No

**Automatically notify support**

No

**Alert Category**

System - Other

**SNMP Trap ID**

**CIM Information**



**Prefix:** PLAT ID: 0143

**User Response**

Information only; no action is required.

- **816f090c-202ffff : [PhysicalMemoryElementName] on Subsystem [MemoryElementName] is no longer Throttled.**

Memory DIMM throttling has been turned off.

**Severity**

Info

**Serviceable**

No

**Automatically notify support**

No

**Alert Category**

System - Other

**SNMP Trap ID**

**CIM Information**

**Prefix:** PLAT ID: 0143

**User Response**

Information only; no action is required.

- **816f090c-2030fff : [PhysicalMemoryElementName] on Subsystem [MemoryElementName] is no longer Throttled.**

Memory DIMM throttling has been turned off.

**Severity**

Info

**Serviceable**

No

**Automatically notify support**

No

**Alert Category**

System - Other

**SNMP Trap ID**

**CIM Information**

**Prefix:** PLAT ID: 0143

**User Response**

Information only; no action is required.

- **816f0a07-0301fff : The Processor [ProcessorElementName] is no longer operating in a Degraded State.**

The microprocessor 1 is no longer being throttled. (or ... has been turned off.)

**Severity**

Info

**Serviceable**

No

**Automatically notify support**

No

**Alert Category**

Warning - CPU

**SNMP Trap ID**

42

**CIM Information**

**Prefix:** PLAT ID: 0039

**User Response**

Information only; no action is required.

- **816f0a07-0302ffff : The Processor [ProcessorElementName] is no longer operating in a Degraded State.**

The microprocessor 2 is no longer being throttled. (or ... has been turned off.)

**Severity**

Info

**Serviceable**

No

**Automatically notify support**

No

**Alert Category**

Warning - CPU

**SNMP Trap ID**

42

**CIM Information**

**Prefix:** PLAT ID: 0039

**User Response**

Information only; no action is required.

- **816f0a07-0303ffff : The Processor [ProcessorElementName] is no longer operating in a Degraded State.**

The microprocessor 3 is no longer being throttled. (or ... has been turned off.)

**Severity**

Info

**Serviceable**

No

**Automatically notify support**

No

**Alert Category**

Warning - CPU

**SNMP Trap ID**

42

**CIM Information**

**Prefix:** PLAT ID: 0039

**User Response**

Information only; no action is required.

- **816f0a07-0304ffff : The Processor [ProcessorElementName] is no longer operating in a Degraded State.**

The microprocessor 4 is no longer being throttled. (or ... has been turned off.)

**Severity**

Info

**Serviceable**

No

**Automatically notify support**

No

**Alert Category**

Warning - CPU

**SNMP Trap ID**

42

**CIM Information**

Prefix: PLAT ID: 0039

**User Response**

Information only; no action is required.

- **816f0a07-2584ffff : The Processor [ProcessorElementName] is no longer operating in a Degraded State.**

The microprocessor is no longer being throttled. (or ... has been turned off.) All CPUs. One of CPUs.

**Severity**

Info

**Serviceable**

Yes

**Automatically notify support**

No

**Alert Category**

Warning - CPU

**SNMP Trap ID**

42

**CIM Information**

Prefix: PLAT ID: 0039

**User Response**

Information only; no action is required.

- **816f0a0c-2001ffff : An Over-Temperature Condition has been removed on the [PhysicalMemoryElementName] on Subsystem [MemoryElementName].**

Memory DIMM is no longer in an over-temperature condition.

**Severity**

Info

**Serviceable**

No

**Automatically notify support**

No

**Alert Category**

Critical - Temperature

**SNMP Trap ID**

0

**CIM Information**

Prefix: PLAT ID: 0147

**User Response**

Information only; no action is required.

- **816f0a0c-2002ffff : An Over-Temperature Condition has been removed on the [PhysicalMemoryElementName] on Subsystem [MemoryElementName].**

Memory DIMM is no longer in an over-temperature condition.

**Severity**

Info

**Serviceable**

No

**Automatically notify support**

No

**Alert Category**

Critical - Temperature

**SNMP Trap ID**

0

**CIM Information**

Prefix: PLAT ID: 0147

**User Response**

Information only; no action is required.

- **816f0a0c-2003ffff : An Over-Temperature Condition has been removed on the [PhysicalMemoryElementName] on Subsystem [MemoryElementName].**

Memory DIMM is no longer in an over-temperature condition.

**Severity**

Info

**Serviceable**

No

**Automatically notify support**

No

**Alert Category**

Critical - Temperature

**SNMP Trap ID**

0

**CIM Information**

Prefix: PLAT ID: 0147

**User Response**

Information only; no action is required.

- **816f0a0c-2004ffff : An Over-Temperature Condition has been removed on the [PhysicalMemoryElementName] on Subsystem [MemoryElementName].**

Memory DIMM is no longer in an over-temperature condition.

**Severity**

Info

**Serviceable**

No

**Automatically notify support**

No

**Alert Category**

Critical - Temperature

**SNMP Trap ID**

0

**CIM Information**

**Prefix: PLAT ID:** 0147

**User Response**

Information only; no action is required.

- **816f0a0c-2005ffff : An Over-Temperature Condition has been removed on the [PhysicalMemoryElementName] on Subsystem [MemoryElementName].**

Memory DIMM is no longer in an over-temperature condition.

**Severity**

Info

**Serviceable**

No

**Automatically notify support**

No

**Alert Category**

Critical - Temperature

**SNMP Trap ID**

0

**CIM Information**

**Prefix: PLAT ID:** 0147

**User Response**

Information only; no action is required.

- **816f0a0c-2006ffff : An Over-Temperature Condition has been removed on the [PhysicalMemoryElementName] on Subsystem [MemoryElementName].**

Memory DIMM is no longer in an over-temperature condition.

**Severity**

Info

**Serviceable**

No

**Automatically notify support**

No

**Alert Category**

Critical - Temperature

**SNMP Trap ID**

0

**CIM Information**

Prefix: PLAT ID: 0147

**User Response**

Information only; no action is required.

- **816f0a0c-2007ffff : An Over-Temperature Condition has been removed on the [PhysicalMemoryElementName] on Subsystem [MemoryElementName].**

Memory DIMM is no longer in an over-temperature condition.

**Severity**

Info

**Serviceable**

No

**Automatically notify support**

No

**Alert Category**

Critical - Temperature

**SNMP Trap ID**

0

**CIM Information**

Prefix: PLAT ID: 0147

**User Response**

Information only; no action is required.

- **816f0a0c-2008ffff : An Over-Temperature Condition has been removed on the [PhysicalMemoryElementName] on Subsystem [MemoryElementName].**

Memory DIMM is no longer in an over-temperature condition.

**Severity**

Info

**Serviceable**

No

**Automatically notify support**

No

**Alert Category**

Critical - Temperature

**SNMP Trap ID**

0

**CIM Information**

Prefix: PLAT ID: 0147

**User Response**

Information only; no action is required.

- **816f0a0c-2009ffff : An Over-Temperature Condition has been removed on the [PhysicalMemoryElementName] on Subsystem [MemoryElementName].**

Memory DIMM is no longer in an over-temperature condition.

**Severity**

Info

**Serviceable**

No

**Automatically notify support**

No

**Alert Category**

Critical - Temperature

**SNMP Trap ID**

0

**CIM Information**

**Prefix: PLAT ID:** 0147

**User Response**

Information only; no action is required.

- **816f0a0c-200afff : An Over-Temperature Condition has been removed on the [PhysicalMemoryElementName] on Subsystem [MemoryElementName].**

Memory DIMM is no longer in an over-temperature condition.

**Severity**

Info

**Serviceable**

No

**Automatically notify support**

No

**Alert Category**

Critical - Temperature

**SNMP Trap ID**

0

**CIM Information**

**Prefix: PLAT ID:** 0147

**User Response**

Information only; no action is required.

- **816f0a0c-200bfff : An Over-Temperature Condition has been removed on the [PhysicalMemoryElementName] on Subsystem [MemoryElementName].**

Memory DIMM is no longer in an over-temperature condition.

**Severity**

Info

**Serviceable**

No

**Automatically notify support**

No

**Alert Category**

Critical - Temperature

**SNMP Trap ID**

0

**CIM Information**

**Prefix: PLAT ID: 0147**

**User Response**

Information only; no action is required.

- **816f0a0c-200cffff : An Over-Temperature Condition has been removed on the [PhysicalMemoryElementName] on Subsystem [MemoryElementName].**

Memory DIMM is no longer in an over-temperature condition.

**Severity**

Info

**Serviceable**

No

**Automatically notify support**

No

**Alert Category**

Critical - Temperature

**SNMP Trap ID**

0

**CIM Information**

**Prefix: PLAT ID: 0147**

**User Response**

Information only; no action is required.

- **816f0a0c-200dffff : An Over-Temperature Condition has been removed on the [PhysicalMemoryElementName] on Subsystem [MemoryElementName].**

Memory DIMM is no longer in an over-temperature condition.

**Severity**

Info

**Serviceable**

No

**Automatically notify support**

No

**Alert Category**

Critical - Temperature

**SNMP Trap ID**

0

**CIM Information**

**Prefix: PLAT ID: 0147**

**User Response**

Information only; no action is required.

- **816f0a0c-200effff : An Over-Temperature Condition has been removed on the [PhysicalMemoryElementName] on Subsystem [MemoryElementName].**

Memory DIMM is no longer in an over-temperature condition.

**Severity**

Info

**Serviceable**

No



**Automatically notify support**

No

**Alert Category**

Critical - Temperature

**SNMP Trap ID**

0

**CIM Information**

**Prefix: PLAT ID:** 0147

**User Response**

Information only; no action is required.

- **816f0a0c-200ffff : An Over-Temperature Condition has been removed on the [PhysicalMemoryElementName] on Subsystem [MemoryElementName].**

Memory DIMM is no longer in an over-temperature condition.

**Severity**

Info

**Serviceable**

No

**Automatically notify support**

No

**Alert Category**

Critical - Temperature

**SNMP Trap ID**

0

**CIM Information**

**Prefix: PLAT ID:** 0147

**User Response**

Information only; no action is required.

- **816f0a0c-2010fff : An Over-Temperature Condition has been removed on the [PhysicalMemoryElementName] on Subsystem [MemoryElementName].**

Memory DIMM is no longer in an over-temperature condition.

**Severity**

Info

**Serviceable**

No

**Automatically notify support**

No

**Alert Category**

Critical - Temperature

**SNMP Trap ID**

0

**CIM Information**

**Prefix: PLAT ID:** 0147

**User Response**

Information only; no action is required.

- **816f0a0c-2011ffff : An Over-Temperature Condition has been removed on the [PhysicalMemoryElementName] on Subsystem [MemoryElementName].**

Memory DIMM is no longer in an over-temperature condition.

**Severity**

Info

**Serviceable**

No

**Automatically notify support**

No

**Alert Category**

Critical - Temperature

**SNMP Trap ID**

0

**CIM Information**

Prefix: PLAT ID: 0147

**User Response**

Information only; no action is required.

- **816f0a0c-2012ffff : An Over-Temperature Condition has been removed on the [PhysicalMemoryElementName] on Subsystem [MemoryElementName].**

Memory DIMM is no longer in an over-temperature condition.

**Severity**

Info

**Serviceable**

No

**Automatically notify support**

No

**Alert Category**

Critical - Temperature

**SNMP Trap ID**

0

**CIM Information**

Prefix: PLAT ID: 0147

**User Response**

Information only; no action is required.

- **816f0a0c-2013ffff : An Over-Temperature Condition has been removed on the [PhysicalMemoryElementName] on Subsystem [MemoryElementName].**

Memory DIMM is no longer in an over-temperature condition.

**Severity**

Info

**Serviceable**

No

**Automatically notify support**

No

**Alert Category**

Critical - Temperature

**SNMP Trap ID**

0

**CIM Information**

Prefix: PLAT ID: 0147

**User Response**

Information only; no action is required.

- **816f0a0c-2014ffff : An Over-Temperature Condition has been removed on the [PhysicalMemoryElementName] on Subsystem [MemoryElementName].**

Memory DIMM is no longer in an over-temperature condition.

**Severity**

Info

**Serviceable**

No

**Automatically notify support**

No

**Alert Category**

Critical - Temperature

**SNMP Trap ID**

0

**CIM Information**

Prefix: PLAT ID: 0147

**User Response**

Information only; no action is required.

- **816f0a0c-2015ffff : An Over-Temperature Condition has been removed on the [PhysicalMemoryElementName] on Subsystem [MemoryElementName].**

Memory DIMM is no longer in an over-temperature condition.

**Severity**

Info

**Serviceable**

No

**Automatically notify support**

No

**Alert Category**

Critical - Temperature

**SNMP Trap ID**

0

**CIM Information**

Prefix: PLAT ID: 0147

**User Response**

Information only; no action is required.

- **816f0a0c-2016ffff : An Over-Temperature Condition has been removed on the [PhysicalMemoryElementName] on Subsystem [MemoryElementName].**

Memory DIMM is no longer in an over-temperature condition.

**Severity**

Info

**Serviceable**

No

**Automatically notify support**

No

**Alert Category**

Critical - Temperature

**SNMP Trap ID**

0

**CIM Information**

Prefix: PLAT ID: 0147

**User Response**

Information only; no action is required.

- **816f0a0c-2017ffff : An Over-Temperature Condition has been removed on the [PhysicalMemoryElementName] on Subsystem [MemoryElementName].**

Memory DIMM is no longer in an over-temperature condition.

**Severity**

Info

**Serviceable**

No

**Automatically notify support**

No

**Alert Category**

Critical - Temperature

**SNMP Trap ID**

0

**CIM Information**

Prefix: PLAT ID: 0147

**User Response**

Information only; no action is required.

- **816f0a0c-2018ffff : An Over-Temperature Condition has been removed on the [PhysicalMemoryElementName] on Subsystem [MemoryElementName].**

Memory DIMM is no longer in an over-temperature condition.

**Severity**

Info

**Serviceable**

No

**Automatically notify support**

No

**Alert Category**

Critical - Temperature

**SNMP Trap ID**

0

**CIM Information**

Prefix: PLAT ID: 0147

**User Response**

Information only; no action is required.

- **816f0a0c-2019ffff : An Over-Temperature Condition has been removed on the [PhysicalMemoryElementName] on Subsystem [MemoryElementName].**

Memory DIMM is no longer in an over-temperature condition.

**Severity**

Info

**Serviceable**

No

**Automatically notify support**

No

**Alert Category**

Critical - Temperature

**SNMP Trap ID**

0

**CIM Information**

Prefix: PLAT ID: 0147

**User Response**

Information only; no action is required.

- **816f0a0c-201affff : An Over-Temperature Condition has been removed on the [PhysicalMemoryElementName] on Subsystem [MemoryElementName].**

Memory DIMM is no longer in an over-temperature condition.

**Severity**

Info

**Serviceable**

No

**Automatically notify support**

No

**Alert Category**

Critical - Temperature

**SNMP Trap ID**

0

**CIM Information**

Prefix: PLAT ID: 0147

**User Response**

Information only; no action is required.

- **816f0a0c-201bffff : An Over-Temperature Condition has been removed on the [PhysicalMemoryElementName] on Subsystem [MemoryElementName].**

Memory DIMM is no longer in an over-temperature condition.

**Severity**

Info

**Serviceable**

No

**Automatically notify support**

No

**Alert Category**

Critical - Temperature

**SNMP Trap ID**

0

**CIM Information**

Prefix: PLAT ID: 0147

**User Response**

Information only; no action is required.

- **816f0a0c-201cfff : An Over-Temperature Condition has been removed on the [PhysicalMemoryElementName] on Subsystem [MemoryElementName].**

Memory DIMM is no longer in an over-temperature condition.

**Severity**

Info

**Serviceable**

No

**Automatically notify support**

No

**Alert Category**

Critical - Temperature

**SNMP Trap ID**

0

**CIM Information**

Prefix: PLAT ID: 0147

**User Response**

Information only; no action is required.

- **816f0a0c-201dfff : An Over-Temperature Condition has been removed on the [PhysicalMemoryElementName] on Subsystem [MemoryElementName].**

Memory DIMM is no longer in an over-temperature condition.

**Severity**

Info

**Serviceable**

No

**Automatically notify support**

No

**Alert Category**

Critical - Temperature

**SNMP Trap ID**

0

**CIM Information**

**Prefix:** PLAT ID: 0147

**User Response**

Information only; no action is required.

- **816f0a0c-201effff : An Over-Temperature Condition has been removed on the [PhysicalMemoryElementName] on Subsystem [MemoryElementName].**

Memory DIMM is no longer in an over-temperature condition.

**Severity**

Info

**Serviceable**

No

**Automatically notify support**

No

**Alert Category**

Critical - Temperature

**SNMP Trap ID**

0

**CIM Information**

**Prefix:** PLAT ID: 0147

**User Response**

Information only; no action is required.

- **816f0a0c-201ffff : An Over-Temperature Condition has been removed on the [PhysicalMemoryElementName] on Subsystem [MemoryElementName].**

Memory DIMM is no longer in an over-temperature condition.

**Severity**

Info

**Serviceable**

No

**Automatically notify support**

No

**Alert Category**

Critical - Temperature

**SNMP Trap ID**

0

**CIM Information**

**Prefix:** PLAT ID: 0147

**User Response**

Information only; no action is required.

- **816f0a0c-2020ffff : An Over-Temperature Condition has been removed on the [PhysicalMemoryElementName] on Subsystem [MemoryElementName].**

Memory DIMM is no longer in an over-temperature condition.

**Severity**

Info

**Serviceable**

No

**Automatically notify support**

No

**Alert Category**

Critical - Temperature

**SNMP Trap ID**

0

**CIM Information**

Prefix: PLAT ID: 0147

**User Response**

Information only; no action is required.

- **816f0a0c-2021ffff : An Over-Temperature Condition has been removed on the [PhysicalMemoryElementName] on Subsystem [MemoryElementName].**

Memory DIMM is no longer in an over-temperature condition.

**Severity**

Info

**Serviceable**

No

**Automatically notify support**

No

**Alert Category**

Critical - Temperature

**SNMP Trap ID**

0

**CIM Information**

Prefix: PLAT ID: 0147

**User Response**

Information only; no action is required.

- **816f0a0c-2022ffff : An Over-Temperature Condition has been removed on the [PhysicalMemoryElementName] on Subsystem [MemoryElementName].**

Memory DIMM is no longer in an over-temperature condition.

**Severity**

Info

**Serviceable**

No

**Automatically notify support**

No

**Alert Category**

Critical - Temperature

**SNMP Trap ID**

0

**CIM Information**

Prefix: PLAT ID: 0147

**User Response**

Information only; no action is required.



- **816f0a0c-2023ffff : An Over-Temperature Condition has been removed on the [PhysicalMemoryElementName] on Subsystem [MemoryElementName].**

Memory DIMM is no longer in an over-temperature condition.

**Severity**

Info

**Serviceable**

No

**Automatically notify support**

No

**Alert Category**

Critical - Temperature

**SNMP Trap ID**

0

**CIM Information**

Prefix: PLAT ID: 0147

**User Response**

Information only; no action is required.

- **816f0a0c-2024ffff : An Over-Temperature Condition has been removed on the [PhysicalMemoryElementName] on Subsystem [MemoryElementName].**

Memory DIMM is no longer in an over-temperature condition.

**Severity**

Info

**Serviceable**

No

**Automatically notify support**

No

**Alert Category**

Critical - Temperature

**SNMP Trap ID**

0

**CIM Information**

Prefix: PLAT ID: 0147

**User Response**

Information only; no action is required.

- **816f0a0c-2025ffff : An Over-Temperature Condition has been removed on the [PhysicalMemoryElementName] on Subsystem [MemoryElementName].**

Memory DIMM is no longer in an over-temperature condition.

**Severity**

Info

**Serviceable**

No

**Automatically notify support**

No

**Alert Category**

Critical - Temperature

**SNMP Trap ID**

0

**CIM Information**

Prefix: PLAT ID: 0147

**User Response**

Information only; no action is required.

- **816f0a0c-2026ffff : An Over-Temperature Condition has been removed on the [PhysicalMemoryElementName] on Subsystem [MemoryElementName].**

Memory DIMM is no longer in an over-temperature condition.

**Severity**

Info

**Serviceable**

No

**Automatically notify support**

No

**Alert Category**

Critical - Temperature

**SNMP Trap ID**

0

**CIM Information**

Prefix: PLAT ID: 0147

**User Response**

Information only; no action is required.

- **816f0a0c-2027ffff : An Over-Temperature Condition has been removed on the [PhysicalMemoryElementName] on Subsystem [MemoryElementName].**

Memory DIMM is no longer in an over-temperature condition.

**Severity**

Info

**Serviceable**

No

**Automatically notify support**

No

**Alert Category**

Critical - Temperature

**SNMP Trap ID**

0

**CIM Information**

Prefix: PLAT ID: 0147

**User Response**

Information only; no action is required.

- **816f0a0c-2028ffff : An Over-Temperature Condition has been removed on the [PhysicalMemoryElementName] on Subsystem [MemoryElementName].**

Memory DIMM is no longer in an over-temperature condition.

**Severity**

Info

**Serviceable**

No

**Automatically notify support**

No

**Alert Category**

Critical - Temperature

**SNMP Trap ID**

0

**CIM Information**

**Prefix: PLAT ID:** 0147

**User Response**

Information only; no action is required.

- **816f0a0c-2029ffff : An Over-Temperature Condition has been removed on the [PhysicalMemoryElementName] on Subsystem [MemoryElementName].**

Memory DIMM is no longer in an over-temperature condition.

**Severity**

Info

**Serviceable**

No

**Automatically notify support**

No

**Alert Category**

Critical - Temperature

**SNMP Trap ID**

0

**CIM Information**

**Prefix: PLAT ID:** 0147

**User Response**

Information only; no action is required.

- **816f0a0c-202affff : An Over-Temperature Condition has been removed on the [PhysicalMemoryElementName] on Subsystem [MemoryElementName].**

Memory DIMM is no longer in an over-temperature condition.

**Severity**

Info

**Serviceable**

No

**Automatically notify support**

No

**Alert Category**

Critical - Temperature

**SNMP Trap ID**

0

**CIM Information**

Prefix: PLAT ID: 0147

**User Response**

Information only; no action is required.

- **816f0a0c-202bffff : An Over-Temperature Condition has been removed on the [PhysicalMemoryElementName] on Subsystem [MemoryElementName].**

Memory DIMM is no longer in an over-temperature condition.

**Severity**

Info

**Serviceable**

No

**Automatically notify support**

No

**Alert Category**

Critical - Temperature

**SNMP Trap ID**

0

**CIM Information**

Prefix: PLAT ID: 0147

**User Response**

Information only; no action is required.

- **816f0a0c-202cffff : An Over-Temperature Condition has been removed on the [PhysicalMemoryElementName] on Subsystem [MemoryElementName].**

Memory DIMM is no longer in an over-temperature condition.

**Severity**

Info

**Serviceable**

No

**Automatically notify support**

No

**Alert Category**

Critical - Temperature

**SNMP Trap ID**

0

**CIM Information**

Prefix: PLAT ID: 0147

**User Response**

Information only; no action is required.

- **816f0a0c-202dffff : An Over-Temperature Condition has been removed on the [PhysicalMemoryElementName] on Subsystem [MemoryElementName].**

Memory DIMM is no longer in an over-temperature condition.

**Severity**

Info

**Serviceable**

No

**Automatically notify support**

No

**Alert Category**

Critical - Temperature

**SNMP Trap ID**

0

**CIM Information**

**Prefix: PLAT ID:** 0147

**User Response**

Information only; no action is required.

- **816f0a0c-202efff : An Over-Temperature Condition has been removed on the [PhysicalMemoryElementName] on Subsystem [MemoryElementName].**

Memory DIMM is no longer in an over-temperature condition.

**Severity**

Info

**Serviceable**

No

**Automatically notify support**

No

**Alert Category**

Critical - Temperature

**SNMP Trap ID**

0

**CIM Information**

**Prefix: PLAT ID:** 0147

**User Response**

Information only; no action is required.

- **816f0a0c-202ffff : An Over-Temperature Condition has been removed on the [PhysicalMemoryElementName] on Subsystem [MemoryElementName].**

Memory DIMM is no longer in an over-temperature condition.

**Severity**

Info

**Serviceable**

No

**Automatically notify support**

No

**Alert Category**

Critical - Temperature

**SNMP Trap ID**

0

**CIM Information**

**Prefix: PLAT ID:** 0147

**User Response**

Information only; no action is required.

- **816f0a0c-2030ffff : An Over-Temperature Condition has been removed on the [PhysicalMemoryElementName] on Subsystem [MemoryElementName].**

Memory DIMM is no longer in an over-temperature condition.

**Severity**

Info

**Serviceable**

No

**Automatically notify support**

No

**Alert Category**

Critical - Temperature

**SNMP Trap ID**

0

**CIM Information**

**Prefix: PLAT ID:** 0147

**User Response**

Information only; no action is required.

- **816f0a13-2401ffff : System [ComputerSystemElementName] has recovered from a Fatal Bus Error.**

The UEFI has detected that a system has recovered from a System Management Bus Fatal Error.

**Severity**

Info

**Serviceable**

No

**Automatically notify support**

No

**Alert Category**

Critical - Other

**SNMP Trap ID**

50

**CIM Information**

**Prefix: PLAT ID:** 0245

**User Response**

Information only; no action is required.

**Related links**

– “Finding the UEFI diagnostic code” on page 776

- **816f0a13-2582ffff : Bus [SensorElementName] has recovered from a Fatal Bus Error.**

IMM has detected that the system has recovered from a fatal bus error. (All PCI Error or One of PCI Error or PCIs)

**Severity**

Info

**Serviceable**

No

**Automatically notify support**

No

**Alert Category**

Critical - Other

**SNMP Trap ID**

50

**CIM Information****Prefix:** PLAT ID: 0245**User Response**

Information only; no action is required.

**Related links**

– “Finding the UEFI diagnostic code” on page 776

- **816f0b13-0701ffff : Bus [SensorElementName] is no longer operating in a degraded state.**

IMM has detected the DMI Bus is No Longer Degraded.

**Severity**

Info

**Serviceable**

No

**Automatically notify support**

No

**Alert Category**

Warning - Other

**SNMP Trap ID**

60

**CIM Information****Prefix:** PLAT ID: 0247**User Response**

Information only; no action is required.

**IMM Events that automatically notify Support**

You can configure the IBM Flex System Manager or the CMM to automatically notify Support (also known as *call home*) if certain types of errors are encountered. If you have configured this function, see the table for a list of events that automatically notify Support.

Table 9. Events that automatically notify Support

| Event ID          | Message String   | Automatically Notify Support |
|-------------------|--|------------------------------|
| 40000086-00000000 | Test Call Home Generated by user [arg1].   | Yes                          |
| 40000087-00000000 | Manual Call Home by user [arg1]: [arg2].   | Yes                          |
| 80010202-0701ffff | Numeric sensor [NumericSensorElementName] going low (lower critical) has asserted. | Yes                          |
| 80010902-0701ffff | Sensor [NumericSensorElementName] has detected high voltage.                       | Yes                          |

Table 9. Events that automatically notify Support (continued)

| Event ID          | Message String   | Automatically Notify Support |
|-------------------|--|------------------------------|
| 8007021b-0301ffff | Sensor CPU 1 QPILinkErr has transitioned to critical from a less severe state.                 | Yes                          |
| 8007021b-0302ffff | Sensor CPU 2 QPILinkErr has transitioned to critical from a less severe state.                 | Yes                          |
| 8007021b-0303ffff | Sensor CPU 3 QPILinkErr has transitioned to critical from a less severe state.                 | Yes                          |
| 8007021b-0304ffff | Sensor CPU 4 QPILinkErr has transitioned to critical from a less severe state.                 | Yes                          |
| 806f0021-2201ffff | Fault in slot [PhysicalConnectorSystemElementName] on system [ComputerSystemElementName].      | Yes                          |
| 806f0021-25820901 | Fault in slot [PhysicalConnectorSystemElementName] on system [ComputerSystemElementName].      | Yes                          |
| 806f0021-25820903 | Fault in slot [PhysicalConnectorSystemElementName] on system [ComputerSystemElementName].      | Yes                          |
| 806f0021-25820904 | Fault in slot [PhysicalConnectorSystemElementName] on system [ComputerSystemElementName].      | Yes                          |
| 806f0021-2582ffff | Fault in slot [PhysicalConnectorSystemElementName] on system [ComputerSystemElementName].      | Yes                          |
| 806f010c-2001ffff | Uncorrectable error detected for [PhysicalMemoryElementName] on Subsystem [MemoryElementName]. | Yes                          |
| 806f010c-2002ffff | Uncorrectable error detected for [PhysicalMemoryElementName] on Subsystem [MemoryElementName]. | Yes                          |
| 806f010c-2003ffff | Uncorrectable error detected for [PhysicalMemoryElementName] on Subsystem [MemoryElementName]. | Yes                          |
| 806f010c-2004ffff | Uncorrectable error detected for [PhysicalMemoryElementName] on Subsystem [MemoryElementName]. | Yes                          |
| 806f010c-2005ffff | Uncorrectable error detected for [PhysicalMemoryElementName] on Subsystem [MemoryElementName]. | Yes                          |
| 806f010c-2006ffff | Uncorrectable error detected for [PhysicalMemoryElementName] on Subsystem [MemoryElementName]. | Yes                          |
| 806f010c-2007ffff | Uncorrectable error detected for [PhysicalMemoryElementName] on Subsystem [MemoryElementName]. | Yes                          |
| 806f010c-2008ffff | Uncorrectable error detected for [PhysicalMemoryElementName] on Subsystem [MemoryElementName]. | Yes                          |
| 806f010c-2009ffff | Uncorrectable error detected for [PhysicalMemoryElementName] on Subsystem [MemoryElementName]. | Yes                          |



Table 9. Events that automatically notify Support (continued)

| Event ID          | Message String   | Automatically Notify Support |
|-------------------|--|------------------------------|
| 806f010c-200affff | Uncorrectable error detected for [PhysicalMemoryElementName] on Subsystem [MemoryElementName]. | Yes                          |
| 806f010c-200bffff | Uncorrectable error detected for [PhysicalMemoryElementName] on Subsystem [MemoryElementName]. | Yes                          |
| 806f010c-200cffff | Uncorrectable error detected for [PhysicalMemoryElementName] on Subsystem [MemoryElementName]. | Yes                          |
| 806f010c-200dffff | Uncorrectable error detected for [PhysicalMemoryElementName] on Subsystem [MemoryElementName]. | Yes                          |
| 806f010c-200effff | Uncorrectable error detected for [PhysicalMemoryElementName] on Subsystem [MemoryElementName]. | Yes                          |
| 806f010c-200fffff | Uncorrectable error detected for [PhysicalMemoryElementName] on Subsystem [MemoryElementName]. | Yes                          |
| 806f010c-2010ffff | Uncorrectable error detected for [PhysicalMemoryElementName] on Subsystem [MemoryElementName]. | Yes                          |
| 806f010c-2011ffff | Uncorrectable error detected for [PhysicalMemoryElementName] on Subsystem [MemoryElementName]. | Yes                          |
| 806f010c-2012ffff | Uncorrectable error detected for [PhysicalMemoryElementName] on Subsystem [MemoryElementName]. | Yes                          |
| 806f010c-2013ffff | Uncorrectable error detected for [PhysicalMemoryElementName] on Subsystem [MemoryElementName]. | Yes                          |
| 806f010c-2014ffff | Uncorrectable error detected for [PhysicalMemoryElementName] on Subsystem [MemoryElementName]. | Yes                          |
| 806f010c-2015ffff | Uncorrectable error detected for [PhysicalMemoryElementName] on Subsystem [MemoryElementName]. | Yes                          |
| 806f010c-2016ffff | Uncorrectable error detected for [PhysicalMemoryElementName] on Subsystem [MemoryElementName]. | Yes                          |
| 806f010c-2017ffff | Uncorrectable error detected for [PhysicalMemoryElementName] on Subsystem [MemoryElementName]. | Yes                          |
| 806f010c-2018ffff | Uncorrectable error detected for [PhysicalMemoryElementName] on Subsystem [MemoryElementName]. | Yes                          |

Table 9. Events that automatically notify Support (continued)

| Event ID          | Message String   | Automatically Notify Support |
|-------------------|--|------------------------------|
| 806f010c-2019ffff | Uncorrectable error detected for [PhysicalMemoryElementName] on Subsystem [MemoryElementName]. | Yes                          |
| 806f010c-201affff | Uncorrectable error detected for [PhysicalMemoryElementName] on Subsystem [MemoryElementName]. | Yes                          |
| 806f010c-201bffff | Uncorrectable error detected for [PhysicalMemoryElementName] on Subsystem [MemoryElementName]. | Yes                          |
| 806f010c-201c01ff | Uncorrectable error detected for [PhysicalMemoryElementName] on Subsystem [MemoryElementName]. | Yes                          |
| 806f010c-201cffff | Uncorrectable error detected for [PhysicalMemoryElementName] on Subsystem [MemoryElementName]. | Yes                          |
| 806f010c-201dffff | Uncorrectable error detected for [PhysicalMemoryElementName] on Subsystem [MemoryElementName]. | Yes                          |
| 806f010c-201effff | Uncorrectable error detected for [PhysicalMemoryElementName] on Subsystem [MemoryElementName]. | Yes                          |
| 806f010c-201ffff  | Uncorrectable error detected for [PhysicalMemoryElementName] on Subsystem [MemoryElementName]. | Yes                          |
| 806f010c-2020ffff | Uncorrectable error detected for [PhysicalMemoryElementName] on Subsystem [MemoryElementName]. | Yes                          |
| 806f010c-2021ffff | Uncorrectable error detected for [PhysicalMemoryElementName] on Subsystem [MemoryElementName]. | Yes                          |
| 806f010c-2022ffff | Uncorrectable error detected for [PhysicalMemoryElementName] on Subsystem [MemoryElementName]. | Yes                          |
| 806f010c-2023ffff | Uncorrectable error detected for [PhysicalMemoryElementName] on Subsystem [MemoryElementName]. | Yes                          |
| 806f010c-2024ffff | Uncorrectable error detected for [PhysicalMemoryElementName] on Subsystem [MemoryElementName]. | Yes                          |
| 806f010c-2025ffff | Uncorrectable error detected for [PhysicalMemoryElementName] on Subsystem [MemoryElementName]. | Yes                          |
| 806f010c-2026ffff | Uncorrectable error detected for [PhysicalMemoryElementName] on Subsystem [MemoryElementName]. | Yes                          |

Table 9. Events that automatically notify Support (continued)

| Event ID          | Message String   | Automatically Notify Support |
|-------------------|--|------------------------------|
| 806f010c-2027ffff | Uncorrectable error detected for [PhysicalMemoryElementName] on Subsystem [MemoryElementName]. | Yes                          |
| 806f010c-202802ff | Uncorrectable error detected for [PhysicalMemoryElementName] on Subsystem [MemoryElementName]. | Yes                          |
| 806f010c-2028ffff | Uncorrectable error detected for [PhysicalMemoryElementName] on Subsystem [MemoryElementName]. | Yes                          |
| 806f010c-2029ffff | Uncorrectable error detected for [PhysicalMemoryElementName] on Subsystem [MemoryElementName]. | Yes                          |
| 806f010c-202affff | Uncorrectable error detected for [PhysicalMemoryElementName] on Subsystem [MemoryElementName]. | Yes                          |
| 806f010c-202bffff | Uncorrectable error detected for [PhysicalMemoryElementName] on Subsystem [MemoryElementName]. | Yes                          |
| 806f010c-202cffff | Uncorrectable error detected for [PhysicalMemoryElementName] on Subsystem [MemoryElementName]. | Yes                          |
| 806f010c-202dffff | Uncorrectable error detected for [PhysicalMemoryElementName] on Subsystem [MemoryElementName]. | Yes                          |
| 806f010c-202effff | Uncorrectable error detected for [PhysicalMemoryElementName] on Subsystem [MemoryElementName]. | Yes                          |
| 806f010c-202fffff | Uncorrectable error detected for [PhysicalMemoryElementName] on Subsystem [MemoryElementName]. | Yes                          |
| 806f010c-2030ffff | Uncorrectable error detected for [PhysicalMemoryElementName] on Subsystem [MemoryElementName]. | Yes                          |
| 806f010c-2581ffff | Uncorrectable error detected for [PhysicalMemoryElementName] on Subsystem [MemoryElementName]. | Yes                          |
| 806f010d-0400ffff | The Drive Drive 0 has been disabled due to a detected fault.                                   | Yes                          |
| 806f010d-0401ffff | The Drive Drive 1 has been disabled due to a detected fault.                                   | Yes                          |
| 806f010d-0402ffff | The Drive Drive 2 has been disabled due to a detected fault.                                   | Yes                          |
| 806f010d-0403ffff | The Drive Drive 3 has been disabled due to a detected fault.                                   | Yes                          |
| 806f010d-0404ffff | The Drive Drive 4 has been disabled due to a detected fault.                                   | Yes                          |

Table 9. Events that automatically notify Support (continued)

| Event ID          | Message String   | Automatically Notify Support |
|-------------------|--|------------------------------|
| 806f010d-0405ffff | The Drive Drive 5 has been disabled due to a detected fault.                                 | Yes                          |
| 806f010d-0406ffff | The Drive Drive 6 has been disabled due to a detected fault.                                 | Yes                          |
| 806f010d-0407ffff | The Drive Drive 7 has been disabled due to a detected fault.                                 | Yes                          |
| 806f011b-0c01ffff | The connector LightPath has encountered a configuration error.                               | Yes                          |
| 806f011b-1f03ffff | The connector [PhysicalConnectorElementName] has encountered a configuration error.          | Yes                          |
| 806f011b-1f04ffff | The connector [PhysicalConnectorElementName] has encountered a configuration error.          | Yes                          |
| 806f0207-0302ffff | CPU 2 has Failed with FRB1/BIST condition.   | Yes                          |
| 806f020d-0400ffff | Failure Predicted on drive [StorageVolumeElementName] for array [ComputerSystemElementName]. | Yes                          |
| 806f020d-0401ffff | Failure Predicted on drive [StorageVolumeElementName] for array [ComputerSystemElementName]. | Yes                          |
| 806f020d-0402ffff | Failure Predicted on drive [StorageVolumeElementName] for array [ComputerSystemElementName]. | Yes                          |
| 806f020d-0403ffff | Failure Predicted on drive [StorageVolumeElementName] for array [ComputerSystemElementName]. | Yes                          |
| 806f020d-0404ffff | Failure Predicted on drive [StorageVolumeElementName] for array [ComputerSystemElementName]. | Yes                          |
| 806f020d-0405ffff | Failure Predicted on drive [StorageVolumeElementName] for array [ComputerSystemElementName]. | Yes                          |
| 806f020d-0406ffff | Failure Predicted on drive [StorageVolumeElementName] for array [ComputerSystemElementName]. | Yes                          |
| 806f020d-0407ffff | Failure Predicted on drive [StorageVolumeElementName] for array [ComputerSystemElementName]. | Yes                          |
| 806f030c-2001ffff | Scrub Failure for [PhysicalMemoryElementName] on Subsystem [MemoryElementName].              | Yes                          |
| 806f030c-2002ffff | Scrub Failure for [PhysicalMemoryElementName] on Subsystem [MemoryElementName].              | Yes                          |
| 806f030c-2003ffff | Scrub Failure for [PhysicalMemoryElementName] on Subsystem [MemoryElementName].              | Yes                          |
| 806f030c-200401ff | Scrub Failure for [PhysicalMemoryElementName] on Subsystem [MemoryElementName].              | Yes                          |
| 806f030c-2004ffff | Scrub Failure for [PhysicalMemoryElementName] on Subsystem [MemoryElementName].              | Yes                          |
| 806f030c-2005ffff | Scrub Failure for [PhysicalMemoryElementName] on Subsystem [MemoryElementName].              | Yes                          |

Table 9. Events that automatically notify Support (continued)

| Event ID          | Message String  | Automatically Notify Support |
|-------------------|---|------------------------------|
| 806f030c-2006ffff | Scrub Failure for [PhysicalMemoryElementName] on Subsystem [MemoryElementName]. | Yes                          |
| 806f030c-2007ffff | Scrub Failure for [PhysicalMemoryElementName] on Subsystem [MemoryElementName]. | Yes                          |
| 806f030c-2008ffff | Scrub Failure for [PhysicalMemoryElementName] on Subsystem [MemoryElementName]. | Yes                          |
| 806f030c-2009ffff | Scrub Failure for [PhysicalMemoryElementName] on Subsystem [MemoryElementName]. | Yes                          |
| 806f030c-200affff | Scrub Failure for [PhysicalMemoryElementName] on Subsystem [MemoryElementName]. | Yes                          |
| 806f030c-200bffff | Scrub Failure for [PhysicalMemoryElementName] on Subsystem [MemoryElementName]. | Yes                          |
| 806f030c-200cffff | Scrub Failure for [PhysicalMemoryElementName] on Subsystem [MemoryElementName]. | Yes                          |
| 806f030c-200dffff | Scrub Failure for [PhysicalMemoryElementName] on Subsystem [MemoryElementName]. | Yes                          |
| 806f030c-200effff | Scrub Failure for [PhysicalMemoryElementName] on Subsystem [MemoryElementName]. | Yes                          |
| 806f030c-200fffff | Scrub Failure for [PhysicalMemoryElementName] on Subsystem [MemoryElementName]. | Yes                          |
| 806f030c-2010ffff | Scrub Failure for [PhysicalMemoryElementName] on Subsystem [MemoryElementName]. | Yes                          |
| 806f030c-2011ffff | Scrub Failure for [PhysicalMemoryElementName] on Subsystem [MemoryElementName]. | Yes                          |
| 806f030c-2012ffff | Scrub Failure for [PhysicalMemoryElementName] on Subsystem [MemoryElementName]. | Yes                          |
| 806f030c-2013ffff | Scrub Failure for [PhysicalMemoryElementName] on Subsystem [MemoryElementName]. | Yes                          |
| 806f030c-2014ffff | Scrub Failure for [PhysicalMemoryElementName] on Subsystem [MemoryElementName]. | Yes                          |
| 806f030c-2015ffff | Scrub Failure for [PhysicalMemoryElementName] on Subsystem [MemoryElementName]. | Yes                          |
| 806f030c-2016ffff | Scrub Failure for [PhysicalMemoryElementName] on Subsystem [MemoryElementName]. | Yes                          |
| 806f030c-2017ffff | Scrub Failure for [PhysicalMemoryElementName] on Subsystem [MemoryElementName]. | Yes                          |
| 806f030c-2018ffff | Scrub Failure for [PhysicalMemoryElementName] on Subsystem [MemoryElementName]. | Yes                          |
| 806f030c-2019ffff | Scrub Failure for [PhysicalMemoryElementName] on Subsystem [MemoryElementName]. | Yes                          |
| 806f030c-201affff | Scrub Failure for [PhysicalMemoryElementName] on Subsystem [MemoryElementName]. | Yes                          |

Table 9. Events that automatically notify Support (continued)

| Event ID          | Message String  | Automatically Notify Support |
|-------------------|---|------------------------------|
| 806f030c-201bffff | Scrub Failure for [PhysicalMemoryElementName] on Subsystem [MemoryElementName]. | Yes                          |
| 806f030c-201cffff | Scrub Failure for [PhysicalMemoryElementName] on Subsystem [MemoryElementName]. | Yes                          |
| 806f030c-201dffff | Scrub Failure for [PhysicalMemoryElementName] on Subsystem [MemoryElementName]. | Yes                          |
| 806f030c-201effff | Scrub Failure for [PhysicalMemoryElementName] on Subsystem [MemoryElementName]. | Yes                          |
| 806f030c-201fffff | Scrub Failure for [PhysicalMemoryElementName] on Subsystem [MemoryElementName]. | Yes                          |
| 806f030c-2020ffff | Scrub Failure for [PhysicalMemoryElementName] on Subsystem [MemoryElementName]. | Yes                          |
| 806f030c-2021ffff | Scrub Failure for [PhysicalMemoryElementName] on Subsystem [MemoryElementName]. | Yes                          |
| 806f030c-2022ffff | Scrub Failure for [PhysicalMemoryElementName] on Subsystem [MemoryElementName]. | Yes                          |
| 806f030c-2023ffff | Scrub Failure for [PhysicalMemoryElementName] on Subsystem [MemoryElementName]. | Yes                          |
| 806f030c-2024ffff | Scrub Failure for [PhysicalMemoryElementName] on Subsystem [MemoryElementName]. | Yes                          |
| 806f030c-2025ffff | Scrub Failure for [PhysicalMemoryElementName] on Subsystem [MemoryElementName]. | Yes                          |
| 806f030c-2026ffff | Scrub Failure for [PhysicalMemoryElementName] on Subsystem [MemoryElementName]. | Yes                          |
| 806f030c-2027ffff | Scrub Failure for [PhysicalMemoryElementName] on Subsystem [MemoryElementName]. | Yes                          |
| 806f030c-202802ff | Scrub Failure for [PhysicalMemoryElementName] on Subsystem [MemoryElementName]. | Yes                          |
| 806f030c-2028ffff | Scrub Failure for [PhysicalMemoryElementName] on Subsystem [MemoryElementName]. | Yes                          |
| 806f030c-2029ffff | Scrub Failure for [PhysicalMemoryElementName] on Subsystem [MemoryElementName]. | Yes                          |
| 806f030c-202affff | Scrub Failure for [PhysicalMemoryElementName] on Subsystem [MemoryElementName]. | Yes                          |
| 806f030c-202bffff | Scrub Failure for [PhysicalMemoryElementName] on Subsystem [MemoryElementName]. | Yes                          |
| 806f030c-202cffff | Scrub Failure for [PhysicalMemoryElementName] on Subsystem [MemoryElementName]. | Yes                          |
| 806f030c-202dffff | Scrub Failure for [PhysicalMemoryElementName] on Subsystem [MemoryElementName]. | Yes                          |
| 806f030c-202effff | Scrub Failure for [PhysicalMemoryElementName] on Subsystem [MemoryElementName]. | Yes                          |

Table 9. Events that automatically notify Support (continued)

| Event ID          | Message String   | Automatically Notify Support |
|-------------------|--|------------------------------|
| 806f030c-202ffff  | Scrub Failure for [PhysicalMemoryElementName] on Subsystem [MemoryElementName].                | Yes                          |
| 806f030c-2030ffff | Scrub Failure for [PhysicalMemoryElementName] on Subsystem [MemoryElementName].                | Yes                          |
| 806f030c-2581ffff | Scrub Failure for [PhysicalMemoryElementName] on Subsystem [MemoryElementName].                | Yes                          |
| 806f050c-2001ffff | Memory Logging Limit Reached for [PhysicalMemoryElementName] on Subsystem [MemoryElementName]. | Yes                          |
| 806f050c-2002ffff | Memory Logging Limit Reached for [PhysicalMemoryElementName] on Subsystem [MemoryElementName]. | Yes                          |
| 806f050c-2003ffff | Memory Logging Limit Reached for [PhysicalMemoryElementName] on Subsystem [MemoryElementName]. | Yes                          |
| 806f050c-200401ff | Memory Logging Limit Reached for [PhysicalMemoryElementName] on Subsystem [MemoryElementName]. | Yes                          |
| 806f050c-2004ffff | Memory Logging Limit Reached for [PhysicalMemoryElementName] on Subsystem [MemoryElementName]. | Yes                          |
| 806f050c-2005ffff | Memory Logging Limit Reached for [PhysicalMemoryElementName] on Subsystem [MemoryElementName]. | Yes                          |
| 806f050c-2006ffff | Memory Logging Limit Reached for [PhysicalMemoryElementName] on Subsystem [MemoryElementName]. | Yes                          |
| 806f050c-2007ffff | Memory Logging Limit Reached for [PhysicalMemoryElementName] on Subsystem [MemoryElementName]. | Yes                          |
| 806f050c-2008ffff | Memory Logging Limit Reached for [PhysicalMemoryElementName] on Subsystem [MemoryElementName]. | Yes                          |
| 806f050c-200901ff | Memory Logging Limit Reached for [PhysicalMemoryElementName] on Subsystem [MemoryElementName]. | Yes                          |
| 806f050c-2009ffff | Memory Logging Limit Reached for [PhysicalMemoryElementName] on Subsystem [MemoryElementName]. | Yes                          |
| 806f050c-200affff | Memory Logging Limit Reached for [PhysicalMemoryElementName] on Subsystem [MemoryElementName]. | Yes                          |
| 806f050c-200bffff | Memory Logging Limit Reached for [PhysicalMemoryElementName] on Subsystem [MemoryElementName]. | Yes                          |

Table 9. Events that automatically notify Support (continued)

| Event ID          | Message String   | Automatically Notify Support |
|-------------------|--|------------------------------|
| 806f050c-200cffff | Memory Logging Limit Reached for [PhysicalMemoryElementName] on Subsystem [MemoryElementName]. | Yes                          |
| 806f050c-200dffff | Memory Logging Limit Reached for [PhysicalMemoryElementName] on Subsystem [MemoryElementName]. | Yes                          |
| 806f050c-200effff | Memory Logging Limit Reached for [PhysicalMemoryElementName] on Subsystem [MemoryElementName]. | Yes                          |
| 806f050c-200fffff | Memory Logging Limit Reached for [PhysicalMemoryElementName] on Subsystem [MemoryElementName]. | Yes                          |
| 806f050c-2010ffff | Memory Logging Limit Reached for [PhysicalMemoryElementName] on Subsystem [MemoryElementName]. | Yes                          |
| 806f050c-2011ffff | Memory Logging Limit Reached for [PhysicalMemoryElementName] on Subsystem [MemoryElementName]. | Yes                          |
| 806f050c-2012ffff | Memory Logging Limit Reached for [PhysicalMemoryElementName] on Subsystem [MemoryElementName]. | Yes                          |
| 806f050c-2013ffff | Memory Logging Limit Reached for [PhysicalMemoryElementName] on Subsystem [MemoryElementName]. | Yes                          |
| 806f050c-2014ffff | Memory Logging Limit Reached for [PhysicalMemoryElementName] on Subsystem [MemoryElementName]. | Yes                          |
| 806f050c-2015ffff | Memory Logging Limit Reached for [PhysicalMemoryElementName] on Subsystem [MemoryElementName]. | Yes                          |
| 806f050c-2016ffff | Memory Logging Limit Reached for [PhysicalMemoryElementName] on Subsystem [MemoryElementName]. | Yes                          |
| 806f050c-2017ffff | Memory Logging Limit Reached for [PhysicalMemoryElementName] on Subsystem [MemoryElementName]. | Yes                          |
| 806f050c-2018ffff | Memory Logging Limit Reached for [PhysicalMemoryElementName] on Subsystem [MemoryElementName]. | Yes                          |
| 806f050c-2019ffff | Memory Logging Limit Reached for [PhysicalMemoryElementName] on Subsystem [MemoryElementName]. | Yes                          |
| 806f050c-201affff | Memory Logging Limit Reached for [PhysicalMemoryElementName] on Subsystem [MemoryElementName]. | Yes                          |



Table 9. Events that automatically notify Support (continued)

| Event ID          | Message String   | Automatically Notify Support |
|-------------------|--|------------------------------|
| 806f050c-201bffff | Memory Logging Limit Reached for [PhysicalMemoryElementName] on Subsystem [MemoryElementName]. | Yes                          |
| 806f050c-201cffff | Memory Logging Limit Reached for [PhysicalMemoryElementName] on Subsystem [MemoryElementName]. | Yes                          |
| 806f050c-201dffff | Memory Logging Limit Reached for [PhysicalMemoryElementName] on Subsystem [MemoryElementName]. | Yes                          |
| 806f050c-201effff | Memory Logging Limit Reached for [PhysicalMemoryElementName] on Subsystem [MemoryElementName]. | Yes                          |
| 806f050c-201fffff | Memory Logging Limit Reached for [PhysicalMemoryElementName] on Subsystem [MemoryElementName]. | Yes                          |
| 806f050c-2020ffff | Memory Logging Limit Reached for [PhysicalMemoryElementName] on Subsystem [MemoryElementName]. | Yes                          |
| 806f050c-2021ffff | Memory Logging Limit Reached for [PhysicalMemoryElementName] on Subsystem [MemoryElementName]. | Yes                          |
| 806f050c-2022ffff | Memory Logging Limit Reached for [PhysicalMemoryElementName] on Subsystem [MemoryElementName]. | Yes                          |
| 806f050c-2023ffff | Memory Logging Limit Reached for [PhysicalMemoryElementName] on Subsystem [MemoryElementName]. | Yes                          |
| 806f050c-2024ffff | Memory Logging Limit Reached for [PhysicalMemoryElementName] on Subsystem [MemoryElementName]. | Yes                          |
| 806f050c-2025ffff | Memory Logging Limit Reached for [PhysicalMemoryElementName] on Subsystem [MemoryElementName]. | Yes                          |
| 806f050c-2026ffff | Memory Logging Limit Reached for [PhysicalMemoryElementName] on Subsystem [MemoryElementName]. | Yes                          |
| 806f050c-202702ff | Memory Logging Limit Reached for [PhysicalMemoryElementName] on Subsystem [MemoryElementName]. | Yes                          |
| 806f050c-2027ffff | Memory Logging Limit Reached for [PhysicalMemoryElementName] on Subsystem [MemoryElementName]. | Yes                          |
| 806f050c-2028ffff | Memory Logging Limit Reached for [PhysicalMemoryElementName] on Subsystem [MemoryElementName]. | Yes                          |

Table 9. Events that automatically notify Support (continued)

| Event ID          | Message String   | Automatically Notify Support |
|-------------------|--|------------------------------|
| 806f050c-2029ffff | Memory Logging Limit Reached for [PhysicalMemoryElementName] on Subsystem [MemoryElementName]. | Yes                          |
| 806f050c-202affff | Memory Logging Limit Reached for [PhysicalMemoryElementName] on Subsystem [MemoryElementName]. | Yes                          |
| 806f050c-202bffff | Memory Logging Limit Reached for [PhysicalMemoryElementName] on Subsystem [MemoryElementName]. | Yes                          |
| 806f050c-202cffff | Memory Logging Limit Reached for [PhysicalMemoryElementName] on Subsystem [MemoryElementName]. | Yes                          |
| 806f050c-202dffff | Memory Logging Limit Reached for [PhysicalMemoryElementName] on Subsystem [MemoryElementName]. | Yes                          |
| 806f050c-202effff | Memory Logging Limit Reached for [PhysicalMemoryElementName] on Subsystem [MemoryElementName]. | Yes                          |
| 806f050c-202fffff | Memory Logging Limit Reached for [PhysicalMemoryElementName] on Subsystem [MemoryElementName]. | Yes                          |
| 806f050c-2030ffff | Memory Logging Limit Reached for [PhysicalMemoryElementName] on Subsystem [MemoryElementName]. | Yes                          |
| 806f050c-2581ffff | Memory Logging Limit Reached for [PhysicalMemoryElementName] on Subsystem [MemoryElementName]. | Yes                          |
| 806f060d-0400ffff | Array [ComputerSystemElementName] has failed.  | Yes                          |
| 806f060d-0401ffff | Array [ComputerSystemElementName] has failed.  | Yes                          |
| 806f060d-0402ffff | Array [ComputerSystemElementName] has failed.  | Yes                          |
| 806f060d-0403ffff | Array [ComputerSystemElementName] has failed.  | Yes                          |
| 806f060d-0404ffff | Array [ComputerSystemElementName] has failed.  | Yes                          |
| 806f060d-0405ffff | Array [ComputerSystemElementName] has failed.  | Yes                          |
| 806f060d-0406ffff | Array [ComputerSystemElementName] has failed.  | Yes                          |
| 806f060d-0407ffff | Array [ComputerSystemElementName] has failed.  | Yes                          |
| 806f0813-2581ffff | A Uncorrectable Bus Error has occurred on system [ComputerSystemElementName].                  | Yes                          |
| 806f0813-2584ffff | A Uncorrectable Bus Error has occurred on system [ComputerSystemElementName].                  | Yes                          |

## UEFI diagnostic codes

UEFI diagnostic codes can be generated when the compute node starts or while the compute node is running. UEFI diagnostic codes are logged in the IMM event log in the compute node.

For each event code, the following fields are displayed:

### Event identifier

An identifier that uniquely identifies an event.

### Event description

The logged message string that appears for an event.

### Explanation

Additional information to explain why the event occurred.

### Severity

An indication of the level of concern for the condition. In the event log, the severity is abbreviated to the first character.

- **Info:** The event was recorded for audit purposes, usually a user action or a change of states that is normal behavior.
- **Warning:** The event is not as severe as an error, but if possible, the condition should be corrected before it becomes an error. It might also be a condition that requires additional monitoring or maintenance.
- **Error:** The event is a failure or critical condition that impairs service or an expected function.

### Alert Category

Similar events are grouped in categories. The alert category is in the following format:

*severity - device*

*severity* is one of the following severity levels:

- **Critical:** A key component in the server is no longer functioning.
- **Warning:** The event might progress to a critical level.
- **System:** The event is the result of a system error or a configuration change.

*device component* is the specific device in the compute node that caused the event to be generated.

### User response

The actions that you should perform to resolve the event.

Perform the steps listed in this section in the order shown until the problem is solved. After you perform all of the actions that are described in this field, if you cannot solve the problem, contact Support.

## UEFI diagnostic code fields

For each event code, the following fields are displayed:

### Event identifier

An identifier that uniquely identifies an event.

### Event description

The logged message string that appears for an event.

### Explanation

Additional information to explain why the event occurred.

### Severity

An indication of the level of concern for the condition. The severity is abbreviated in the event log to the first character. The following severities can be displayed.

Table 10. Severity levels

| Severity      | Description   |
|---------------|---|
| Informational | An informational message is something that was recorded for audit purposes, usually a user action or a change of states that is normal behavior.  |
| Warning       | A warning is not as severe as an error, but if possible, the condition should be corrected before it becomes an error. It might also be a condition that requires additional monitoring or maintenance. |
| Error         | An error typically indicates a failure or critical condition that impairs service or an expected function.  |

### User response

Indicates what actions you should perform to resolve the event.

Perform the steps listed in this section in the order shown until the problem is solved. After you perform all of the actions that are described in this field, if you cannot solve the problem, contact Support.

### Finding the UEFI diagnostic code

This topic provides information about finding the UEFI diagnostic code.

Several methods are available to locate the UEFI diagnostic code based on the systems-management platform you are using or if you are viewing test results generated by the DSA Preboot diagnostic program.

**Note:** Not all events have a UEFI diagnostic code associated with the event.

Table 11. Finding the UEFI diagnostic code

| Interface to the UEFI diagnostic code                               | Action   |
|---|--|
| Logged on to Flex System Manager management software (if installed) | <ol style="list-style-type: none"> <li>1. Go to the Problems (Active Status) view and click the name of the problem.</li> <li>2. Click on the <b>Recommendations</b> tab and locate the UEFI diagnostic code.</li> </ol> |
| Logged on to the IMM or CMM web interface                           | <ol style="list-style-type: none"> <li>1. Open the Events menu and click <b>Event Log</b>.</li> <li>2. Click <b>more</b> next to the event message and locate the UEFI diagnostic code.</li> </ol>                       |
| Viewing the DSA Preboot diagnostic program test results             | <ol style="list-style-type: none"> <li>1. Go to the Chassis Event log.</li> <li>2. Scroll to the right and look in the Auxillary Data Column to find the UEFI diagnostic code.</li> </ol>                                |

### List of UEFI events

This section lists all messages that can be sent from UEFI.

- **I.11002 [I.11002] A processor mismatch has been detected between one or more processors in the system. : One or More Mismatched Processors Detected**

#### Severity

Info

## User Response

Complete the following steps:

1. This message could occur with messages about other processor configuration problems. Resolve those messages first.
2. If the problem persists, ensure that matching processors are installed (i.e., matching option part numbers, etc)
3. Verify that the processors are installed in the correct sockets. If not, correct that problem.
4. Check the IBM support site for an applicable service bulletin or firmware update that applies to this processor error.
5. Replace mismatching processor. Inspect the processor socket and replace the system board first if the socket is damaged.

## Related links

- “Removing a microprocessor and heat sink” on page 876
  - “Installing a microprocessor and heat sink” on page 880
  - “Removing and replacing the base assembly” on page 863
- **I.18005 [I.18005] A discrepancy has been detected in the number of cores reported by one or more processor packages within the system. : Processors have mismatched number of cores**

## Severity

Info

## User Response

Complete the following steps:

1. If this is a newly installed option, ensure that matching processors are installed in the correct processor sockets.
2. Check the IBM support site for an applicable service bulletin that applies to this processor error.
3. Replace the processor. Inspect the processor socket and replace the system board first if the socket is damaged.

## Related links

- “Removing a microprocessor and heat sink” on page 876
  - “Installing a microprocessor and heat sink” on page 880
  - “Removing and replacing the base assembly” on page 863
- **I.18006 [I.18006] A mismatch between the maximum allowed QPI link speed has been detected for one or more processor packages. : Processors have mismatched QPI Speed**

## Severity

Info

## User Response

Complete the following steps:

1. If this is a newly installed option, ensure that matching processors are installed in the correct processor sockets.
2. Check the IBM support site for an applicable service bulletin or firmware update that applies to this processor error.
3. Replace the processor. Inspect the processor socket and replace the system board first if the socket is damaged.

## Related links

- “Removing a microprocessor and heat sink” on page 876
- “Installing a microprocessor and heat sink” on page 880
- “Removing and replacing the base assembly” on page 863

- **I.18007 [I.18007] A power segment mismatch has been detected for one or more processor packages. : Processors have mismatched Power Segments**

#### Severity

Info

#### User Response

Complete the following steps:

1. Processors installed do not have the same power requirements
2. Ensure that all Processors have matching power requirements (such as 65, 95, or 130 Watts)
3. If power requirements match, check the IBM support site for an applicable service bulletin or firmware update that applies to this processor error.
4. Replace the processor. Inspect the processor socket and replace the system board first if the socket is damaged

#### Related links

- “Removing a microprocessor and heat sink” on page 876
- “Installing a microprocessor and heat sink” on page 880
- “Removing and replacing the base assembly” on page 863

- **I.18008 [I.18008] Currently, there is no additional information for this event. : Processors have mismatched Internal DDR3 Frequency**

#### Severity

Info

#### User Response

Complete the following steps:

1. Verify that matching DIMMs are installed in the correct population sequence. Correct any configuration issues found.
2. Replace the associated processor. Inspect the processor socket and replace the system board first if the socket is damaged

#### Related links

- “Installing a DIMM ” on page 840
- “Removing a microprocessor and heat sink” on page 876
- “Installing a microprocessor and heat sink” on page 880
- “Removing and replacing the base assembly” on page 863

- **I.18009 [I.18009] A core speed mismatch has been detected for one or more processor packages. : Processors have mismatched Core Speed**

#### Severity

Info

#### User Response

Complete the following steps:

1. Verify that matching processors are installed in the correct processor sockets. Correct any mismatch issues found.
2. Check the IBM support site for an applicable service bulletin or firmware update that applies to this processor error.
3. Replace the processor. Inspect the processor socket and replace the system board first if the socket is damaged.

#### Related links

- “Installing a microprocessor and heat sink” on page 880
- “Removing and replacing the base assembly” on page 863

- **I.1800A [I.1800A] A mismatch has been detected between the speed at which a QPI link has trained between two or more processor packages. : Processors have mismatched Bus Speed**

**Severity**

Info

**User Response**

Complete the following steps:

1. Verify that the processor is a valid option that is listed as a Server Proven device for this system. If not, remove the Processor and install one listed on the Server Proven website.
2. Verify that matching processors are installed in the correct processor sockets. Correct any mismatch found.
3. Check the IBM support site for an applicable service bulletin or firmware update that applies to this processor error.
4. Replace the processor. Inspect the processor socket and replace the system board first if the socket is damaged

**Related links**

- “Removing a microprocessor and heat sink” on page 876
  - “Installing a microprocessor and heat sink” on page 880
  - “Removing and replacing the base assembly” on page 863
- **I.1800B [I.1800B] A cache size mismatch has been detected for one or more processor packages. : Processors have one or more cache levels with mismatched size**

**Severity**

Info

**User Response**

Complete the following steps:

1. Verify that matching processors are installed in the correct processor sockets. Correct any mismatch found.
2. Check the IBM support site for an applicable service bulletin or firmware update that applies to this processor error.
3. Replace the system board.

**Related links**

- “Removing a microprocessor and heat sink” on page 876
  - “Installing a microprocessor and heat sink” on page 880
  - “Removing and replacing the base assembly” on page 863
- **I.1800C [I.1800C] A cache type mismatch has been detected for one or more processor packages. : Processors have one or more cache levels with mismatched type**

**Severity**

Info

**User Response**

Complete the following steps:

1. Verify that matching processors are installed in the correct processor sockets.
2. Check the IBM support site for an applicable service bulletin or firmware update that applies to this processor error.
3. Replace the system board.

**Related links**

- “Removing a microprocessor and heat sink” on page 876

- “Installing a microprocessor and heat sink” on page 880
  - “Removing and replacing the base assembly” on page 863
- **I.1800D [I.1800D] A cache associativity mismatch has been detected for one or more processor packages. : Processors have one or more cache levels with mismatched associativity**

#### Severity

Info

#### User Response

Complete the following steps:

1. Verify that matching processors are installed in the correct processor sockets.
2. Check the IBM support site for an applicable service bulletin or firmware update that applies to this processor error.
3. Replace the system board.

#### Related links

- “Removing a microprocessor and heat sink” on page 876
  - “Installing a microprocessor and heat sink” on page 880
  - “Removing and replacing the base assembly” on page 863
- **I.1800E [I.1800E] A processor model mismatch has been detected for one or more processor packages. : Processors have mismatched Model Number**

#### Severity

Info

#### User Response

Complete the following steps:

1. Verify that matching processors are installed in the correct processor sockets.
2. Check the IBM support site for an applicable service bulletin or firmware update that applies to this Processor error.
3. Replace the system board.

#### Related links

- “Removing a microprocessor and heat sink” on page 876
  - “Installing a microprocessor and heat sink” on page 880
  - “Removing and replacing the base assembly” on page 863
- **I.1800F [I.1800F] A processor family mismatch has been detected for one or more processor packages. : Processors have mismatched Family**

#### Severity

Info

#### User Response

Complete the following steps:

1. Verify that matching processors are installed in the correct processor sockets.
2. Check the IBM support site for an applicable service bulletin or firmware update that applies to this processor error.
3. Replace the system board.

#### Related links

- “Removing a microprocessor and heat sink” on page 876
  - “Installing a microprocessor and heat sink” on page 880
  - “Removing and replacing the base assembly” on page 863
- **I.18010 [I.18010] A processor stepping mismatch has been detected for one or more processor packages. : Processors of the same model have mismatched Stepping ID**



## Severity

Info

## User Response

Complete the following steps:

1. Verify that matching processors are installed in the correct processor sockets.
2. Check the IBM support site for an applicable service bulletin or firmware update that applies to this processor error.
3. Replace the system board.

## Related links

- “Removing a microprocessor and heat sink” on page 876
- “Installing a microprocessor and heat sink” on page 880
- “Removing and replacing the base assembly” on page 863
- **I.2018002 [I.2018002] The device found at Bus % Device % Function % could not be configured due to resource constraints. The Vendor ID for the device is % and the Device ID is %. : OUT\_OF\_RESOURCES (PCI Option ROM)**

## Severity

Info

## User Response

Complete the following steps:

1. If this PCIe device and/or any attached cables were recently installed, moved, serviced or upgraded, reseat the adapter and any attached cables.
2. Check the IBM support site for any applicable service bulletin or UEFI or adapter firmware update that applies to this error. NOTE: It may be necessary to disable unused option ROMs from UEFI F1 setup or ASU or using adapter manufacturer utilities so that adapter firmware can be updated.
3. Move the adapter to a different slot. If a slot is not available or error recurs, replace the adapter.
4. If the adapter was moved to a different slot and the error did not recur, verify that this is not a system limitation. Then replace the system board. Also, if this is not the initial installation and the error persists after adapter replacement, replace the system board.

## Related links

- “Removing an I/O expansion adapter” on page 857
- “Installing an I/O expansion adapter” on page 858
- “Removing and replacing the base assembly” on page 863
- **I.2018003 [I.2018003] A bad option ROM checksum was detected for the device found at Bus % Device % Function %. The Vendor ID for the device is % and the Device ID is %. : ROM CHECKSUM ERROR**

## Severity

Info

## User Response

Complete the following steps:

1. If this PCIe device and/or any attached cables were recently installed, moved, serviced or upgraded, reseat the adapter and any attached cables.
2. Move the adapter to a different system slot, if available.
3. Check the IBM support site for any applicable service bulletin or UEFI or adapter firmware update that applies to this error. NOTE: It may be necessary to configure slot to Gen1 or to use special utility software so that adapter firmware can be upgraded. Gen1/Gen2 settings can be

configured via F1 Setup -> System Settings -> Devices and I/O Ports -> PCIe Gen1/Gen2/Gen3 Speed Selection, or the ASU Utility.

4. Replace the adapter.

#### Related links

- "Removing an I/O expansion adapter" on page 857
- "Installing an I/O expansion adapter" on page 858
- "Using the Setup utility" on page 26

- **I.3048005 [I.3048005] UEFI has booted from the backup flash bank. : Booting Backup UEFI Image**

#### Severity

Info

#### User Response

Complete the following steps:

Return the system to primary bank.

#### Related links

- "Recovering a UEFI image" on page 24

- **I.3808004 [I.3808004] The IMM System Event log (SEL) is full. : IPMI System Event Log is Full**

#### Severity

Info

#### User Response

Complete the following steps:

1. Use the IMM Web Interface to clear the event log.
2. If IMM communication is unavailable, use the Setup Utility to access the System Event Logs Menu and choose Clear IMM System Event Log and Restart Server.

#### Related links

- "Using the Setup utility" on page 26

- **I.3818001 [I.3818001] The firmware image capsule signature for the currently booted flash bank is invalid. : Current Bank CRTM Capsule Update Signature Invalid**

#### Severity

Info

#### User Response

Complete the following steps:

1. Reboot the system. Will come up on backup UEFI image. Update the primary UEFI image.
2. If error does not persist no additional recovery action is required.
3. If error persists, or boot is unsuccessful, replace the system board.

#### Related links

- "Updating firmware and device drivers" on page 23
- "Removing and replacing the base assembly" on page 863

- **I.3818002 [I.3818002] The firmware image capsule signature for the non-booted flash bank is invalid. : Opposite Bank CRTM Capsule Update Signature Invalid**

#### Severity

Info

#### User Response

Complete the following steps:

1. Update the backup UEFI image.
2. If error does not persist, no additional recovery action is required.
3. If error persists, or boot is unsuccessful, replace the system board.

#### Related links

- “Updating firmware and device drivers” on page 23
- “Removing and replacing the base assembly” on page 863

- **I.3818003 [I.3818003] The CRTM flash driver could not lock the secure flash region. : CRTM Could not lock secure flash region**

#### Severity

Info

#### User Response

Complete the following steps:

1. If system failed to boot successfully, DC cycle the system.
2. If system boots to F1 setup, update the UEFI image and reset bank to primary (if required). If the system boots without error, recovery is complete and no additional action is required.
3. If system fails to boot, or if the firmware update attempt fails, replace the system board.

#### Related links

- “Updating firmware and device drivers” on page 23
- “Removing and replacing the base assembly” on page 863

- **I.3868000 [I.3868000] BOFM: System reset performed to reset adapters. : BOFM: System reset performed to reset adapters**

#### Severity

Info

#### User Response

Complete the following steps:

Information only; no action is required.

- **I.3868003 [I.3868003] BOFM: Configuration too large for compatibility mode. : BOFM: Configuration too large for compatibility mode**

#### Severity

Info

#### User Response

Complete the following steps:

Information only; no action is required.

- **I.58015 [I.58015] Memory spare copy initiated. : Spare Copy Started**

#### Severity

Info

#### User Response

Complete the following steps:

Information only; no action is required.

- **I.580A4 [I.580A4] Memory population change detected. : DIMM Population Change Detected**

#### Severity

Info

### User Response

Complete the following steps:

Check system event log for uncorrected DIMM failures and replace those DIMMs.

### Related links

- “Removing a DIMM” on page 839
- “Installing a DIMM ” on page 840

- **I.580A5 [I.580A5] Mirror Fail-over complete. DIMM number % has failed over to to the mirrored copy. : DIMM Mirror Fail-over Detected**

### Severity

Info

### User Response

Complete the following steps:

Check the system-event log for uncorrected DIMM failures and replace those DIMMs.

### Related links

- “Removing a DIMM” on page 839
- “Installing a DIMM ” on page 840

- **I.580A6 [I.580A6] Memory spare copy has completed successfully. : Spare Copy Complete**

### Severity

Info

### User Response

Complete the following steps:

Check system log for related DIMM failures and replace those DIMMs.

### Related links

- “Removing a DIMM” on page 839
- “Installing a DIMM ” on page 840

- **S.1100C [S.1100C] An uncorrectable error has been detected on processor %. : Uncorrectable processor error detected**

### Severity

Error

### User Response

Complete the following steps:

1. Check the IBM support site for an applicable service bulletin or firmware update that applies to this error.
2. Reboot the system. If problem persists, contact Support.

- **S.2011001 [S.2011001] An Uncorrected PCIe Error has Occurred at Bus % Device % Function %. The Vendor ID for the device is % and the Device ID is %. : PCI SERR Detected**

### Severity

Error

### User Response

Complete the following steps:

1. If this compute node and/or any attached cables were recently installed, moved, serviced or upgraded,
  - a. Reseat the adapter and any attached cables.

- b. Reload the device driver.
  - c. If device is not recognized, reconfiguring slot to Gen1 or Gen2 may be required. Gen1/Gen2 settings can be configured via F1 Setup -> System Settings -> Devices and I/O Ports -> PCIe Gen1/Gen2/Gen3 Speed Selection, or the ASU Utility.
2. Check the IBM support site for an applicable device driver, firmware update, or other information that applies to this error. Load the new device driver and install any required firmware updates.
  3. If the problem persists, remove the adapter. If system reboots successfully without the adapter, replace that adapter.
  4. Replace the processor.

#### Related links

- "Removing an I/O expansion adapter" on page 857
  - "Installing an I/O expansion adapter" on page 858
  - "Using the Setup utility" on page 26
  - "Updating firmware and device drivers" on page 23
  - "Removing a microprocessor and heat sink" on page 876
  - "Installing a microprocessor and heat sink" on page 880
- **S.2018001 [S.2018001] An Uncorrected PCIe Error has Occurred at Bus % Device % Function %. The Vendor ID for the device is % and the Device ID is %. : PCIe Uncorrected Error Detected**

#### Severity

Error

#### User Response

Complete the following steps:

1. If this compute node and/or any attached cables were recently installed, moved, serviced or upgraded:
  - a. Reseat the adapter and any attached cables.
  - b. Reload the device driver.
  - c. If device is not recognized, reconfiguring slot to Gen1 or Gen2 may be required. Gen1/Gen2 settings can be configured via F1 Setup -> System Settings -> Devices and I/O Ports -> PCIe Gen1/Gen2/Gen3 Speed Selection, or the ASU Utility.
2. Check the IBM support site for an applicable device driver, firmware update, or other information that applies to this error. Load the new device driver and install any required firmware updates.
3. If the problem persists, remove the adapter. If the system reboots successfully without the adapter, replace that adapter.
4. Replace the processor.

#### Related links

- "Removing an I/O expansion adapter" on page 857
  - "Installing an I/O expansion adapter" on page 858
  - "Using the Setup utility" on page 26
  - "Updating firmware and device drivers" on page 23
  - "Removing a microprocessor and heat sink" on page 876
  - "Installing a microprocessor and heat sink" on page 880
- **S.3020007 [S.3020007] A firmware fault has been detected in the UEFI image. : Internal UEFI Firmware Fault Detected, System halted**

#### Severity

Error

#### User Response

Complete the following steps:

1. Check the IBM support site for an applicable service bulletin or firmware update that applies to this error.
2. Update the UEFI image.
3. Replace the system board.

**Related links**

- “Updating firmware and device drivers” on page 23
- “Removing and replacing the base assembly” on page 863

- **S.3028002 [S.3028002] Boot permission timeout detected. : Boot Permission Negotiation Timeout**

**Severity**

Error

**User Response**

Complete the following steps:

1. Check CMM/IMM logs for communication errors and resolve.
2. Reseat the system.
3. If problem persists, contact Support.

- **S.3030007 [S.3030007] A firmware fault has been detected in the UEFI image. : Internal UEFI Firmware Fault Detected, System halted**

**Severity**

Error

**User Response**

Complete the following steps:

1. Check the IBM support site for an applicable service bulletin or firmware update that applies to this error.
2. Update the UEFI image.
3. Replace the system board.

**Related links**

- “Updating firmware and device drivers” on page 23
- “Removing and replacing the base assembly” on page 863

- **S.3040007 [S.3040007] A firmware fault has been detected in the UEFI image. : Internal UEFI Firmware Fault Detected, System halted**

**Severity**

Error

**User Response**

Complete the following steps:

1. Check the IBM support site for an applicable service bulletin or firmware update that applies to this error.
2. Update the UEFI image.
3. Replace the system board.

**Related links**

- “Updating firmware and device drivers” on page 23
- “Removing and replacing the base assembly” on page 863

- **S.3050007 [S.3050007] A firmware fault has been detected in the UEFI image. : Internal UEFI Firmware Fault Detected, System halted**

**Severity**

Error

### User Response

Complete the following steps:

1. Check the IBM support site for an applicable service bulletin or firmware update that applies to this error.
2. Update the UEFI image.
3. Replace the system board.

### Related links

- “Updating firmware and device drivers” on page 23
- “Removing and replacing the base assembly” on page 863
- **S.3058004 [S.3058004] A Three Strike boot failure has occurred. The system has booted with default UEFI settings. : POST failure has occurred! System booted with default settings.**

### Severity

Error

### User Response

Complete the following steps:

1. This event resets UEFI to the default settings for the next boot. If successful, the Setup Utility is displayed. The original UEFI settings are still present.
2. If you did not intentionally trigger the reboots, check logs for probable cause.
3. Undo recent system changes (settings or devices added). If there were no recent system changes, remove all options, and then remove the CMOS battery for 30 seconds to clear CMOS contents. Verify that the system boots. Then, re-install the options one at a time to locate the problem.
4. Check the IBM support site for an applicable service bulletin or firmware update that applies to this error.
5. Update the UEFI firmware.
6. Remove and re-install CMOS battery for 30 seconds to clear CMOS contents
7. Replace the system board.

### Related links

- “Removing the CMOS battery” on page 834
- “Installing the CMOS battery” on page 835
- “Updating firmware and device drivers” on page 23
- “Using the Setup utility” on page 26
- “Removing and replacing the base assembly” on page 863
- **S.3060007 [S.3060007] A firmware fault has been detected in the UEFI image. : Internal UEFI Firmware Fault Detected, System halted**

### Severity

Error

### User Response

Complete the following steps:

1. Check the IBM support site for an applicable service bulletin or firmware update that applies to this error.
2. Update the UEFI image.
3. Replace the system board.

### Related links

- "Updating firmware and device drivers" on page 23
- "Removing and replacing the base assembly" on page 863
- **S.3070007 [S.3070007] A firmware fault has been detected in the UEFI image. : Internal UEFI Firmware Fault Detected, System halted**

**Severity**

Error

**User Response**

Complete the following steps:

1. Check the IBM support site for an applicable service bulletin or firmware update that applies to this error.
2. Update the UEFI image.
3. Replace the system board.

**Related links**

- "Updating firmware and device drivers" on page 23
- "Removing and replacing the base assembly" on page 863
- **S.3108007 [S.3108007] The default system settings have been restored. : System Configuration Restored to Defaults**

**Severity**

Error

**User Response**

Complete the following steps:

Check the IBM support site for an applicable service bulletin or firmware update that applies to this error.

**Related links**

- "Updating firmware and device drivers" on page 23
- **S.3818004 [S.3818004] The CRTM flash driver could not successfully flash the staging area. A failure occurred. : CRTM Update Failed**

**Severity**

Error

**User Response**

Complete the following steps:

1. Continue booting the system. If the system does not reset, manually reset the system.
2. If the error is not reported on the subsequent boot, no additional recovery action is required.
3. If the error persists, continue booting system and update the UEFI image.
4. Replace the system board.

**Related links**

- "Updating firmware and device drivers" on page 23
- "Removing and replacing the base assembly" on page 863
- **S.3818007 [S.3818007] The firmware image capsules for both flash banks could not be verified. : CRTM image capsule could not be verified**

**Severity**

Error

**User Response**

Complete the following steps:



1. If system failed to boot successfully, DC cycle system.
2. If system boots to F1 setup, update the UEFI image and reset bank to primary (if required). If the system boots without error, recovery is complete and no additional action is required.
3. If system fails to boot, or if the firmware update attempt fails, replace the system board.

#### Related links

- "Updating firmware and device drivers" on page 23
- "Removing and replacing the base assembly" on page 863
- **S.51003 [S.51003] An uncorrectable memory error was detected in DIMM slot % on rank % . : [S.51003] An uncorrectable memory error was detected on processor % channel %. The failing DIMM within the channel could not be determined.[S.51003] An uncorrectable memory error has been detected during POST. Fatal Memory Error Occurred**

#### Severity

Error

#### User Response

Complete the following steps:

1. Prior to replacing memory DIMM, refer to TIP H212154 for minimum code level.
2. If the compute node has recently been installed, moved, serviced, or upgraded, verify that the DIMM is properly seated and visually verify that there is no foreign material in any DIMM connector on that memory channel. If either of these conditions is found, correct and retry with the same DIMM. (Note: The event Log might contain a recent 00580A4 event denoting detected change in DIMM population that could be related to this problem.)
3. If no problem is observed on the DIMM connectors or the problem persists, replace the DIMM identified by LightPath and/or event log entry.
4. If problem recurs on the same DIMM connector, replace the other DIMMs on the same memory channel.
5. Check the IBM support site for an applicable service bulletin or firmware update that applies to this memory error.
6. If problem recurs on the same DIMM connector, inspect connector for damage. If found, replace the system board.
7. Replace the affected Processor.
8. Replace system board.

#### Related links

- "Removing a DIMM" on page 839
- "Installing a DIMM " on page 840
- "Removing a microprocessor and heat sink" on page 876
- "Installing a microprocessor and heat sink" on page 880
- "Removing and replacing the base assembly" on page 863
- **S.51006 [S.51006] A memory mismatch has been detected. Please verify that the memory configuration is valid. : One or More Mismatched DIMMs Detected**

#### Severity

Error

#### User Response

Complete the following steps:

1. Could follow an uncorrectable memory error or failed memory test. Check the log and service that event first. DIMMs disabled by other errors or actions could cause this event.
2. Verify that the DIMMs are installed in the correct population sequence.

3. Disable memory mirroring and sparing. If this action eliminates the mismatch, check the IBM Support site for information related to this problem.
4. Update UEFI firmware.
5. Replace the DIMM
6. Replace the processor.

#### Related links

- “Removing a DIMM” on page 839
- “Installing a DIMM ” on page 840
- “Removing a microprocessor and heat sink” on page 876
- “Installing a microprocessor and heat sink” on page 880

- **S.51009 [S.51009] No system memory has been detected. : No Memory Detected**

#### Severity

Error

#### User Response

Complete the following steps:

1. If any memory errors are logged other than this one, take actions indicated for those codes first.
2. If no other memory diagnostic codes appear in the logs, verify that all DIMM connectors are enabled using the Setup utility or the Advanced Settings Utility (ASU).
3. If the problem remains, shut down and remove node from chassis and physically verify that one or more DIMMs are installed and that all DIMMs are installed in the correct population sequence.
4. If DIMMs are present and properly installed, check for any lit DIMM-connector LEDs, and if found, reseat those DIMMs.
5. Reinstall node in chassis, power on node, then check logs for memory diagnostic codes.
6. If the problem remains, replace the processor.
7. If the problem remains, replace the system board.

#### Related links

- “Removing a DIMM” on page 839
- “Installing a DIMM ” on page 840
- “Using the Setup utility” on page 26
- “Removing a microprocessor and heat sink” on page 876
- “Installing a microprocessor and heat sink” on page 880
- “Removing and replacing the base assembly” on page 863

- **S.58008 [S.58008] A DIMM has failed the POST memory test. : DIMM Failed Memory Test**

#### Severity

Error

#### User Response

Complete the following steps:

1. Prior to replacing memory DIMM, refer to TIP H212154 for minimum code level.
2. You must AC-cycle the system to re-enable the affected DIMM connector or re-enable manually using the Setup utility.
3. If the compute node has been recently installed, serviced, moved, or upgraded, check to ensure that DIMMs are firmly seated and that no foreign material can be seen in the DIMM connector. If either condition is observed, correct and retry with the same DIMM. (Note: The event Log might contain a recent 00580A4 event denoting detected change in DIMM population that could be related to this problem.)
4. If problem persists, replace the DIMM identified by LightPath and/or event log entry.

5. If problem recurs on the same DIMM connector, swap the other DIMMs on the same memory channel across channels one at a time to a different memory channel or processor. If problem follows a moved DIMM to a different memory channel, replace that DIMM.
6. Check the IBM support site for an applicable service bulletin or firmware update that applies to this memory error.
7. If problem stays with the original DIMM connector, re-inspect DIMM connector for foreign material and remove, if found. If connector is damaged, replace system board.
8. Remove the affected processor and inspect the processor socket pins for damaged or misaligned pins. If damage is found, or this is an upgrade processor, replace the system board. If there are multiple processors, swap them to move affected processor to another processor socket and retry. If problem follows the affected processor (or there is only one processor), replace the affected processor.
9. Replace the system board.

#### Related links

- “Removing a DIMM” on page 839
- “Installing a DIMM ” on page 840
- “Using the Setup utility” on page 26
- “Removing a microprocessor and heat sink” on page 876
- “Installing a microprocessor and heat sink” on page 880
- “Removing and replacing the base assembly” on page 863
- **S.68005 [S.68005] An error has been detected by the the IIO core logic on Bus %. The Global Fatal Error Status register contains %. The Global Non-Fatal Error Status register contains %. Please check error logs for the presence of additional downstream device error data. : Critical IOH-PCI Error**

#### Severity

Error

#### User Response

Complete the following steps:

1. Check the log for a separate error related to an associated PCIe device and resolve that error.
2. Check the IBM support site for an applicable service bulletin or firmware update for the system or adapter that applies to this error.
3. Replace the system board.

#### Related links

- “Removing and replacing the base assembly” on page 863
- **S.680B8 [S.680B8] Internal QPI Link Failure Detected. : Internal QPI Link Failure Detected**

#### Severity

Error

#### User Response

Complete the following steps:

1. Check the IBM support site for an applicable service bulletin or firmware update that applies to this error.
2. Inspect the processor socket for foreign debris or damage. If debris is found, remove the debris.
3. If error recurs, or socket damage is found, replace the system board.

#### Related links

- “Removing a microprocessor and heat sink” on page 876
- “Installing a microprocessor and heat sink” on page 880
- “Removing and replacing the base assembly” on page 863

- **S.680B9 [S.680B9] External QPI Link Failure Detected. : External QPI Link Failure Detected**

**Severity**

Error

**User Response**

Complete the following steps:

1. Check the IBM support site for an applicable service bulletin or firmware update that applies to this error.
2. Inspect the processor socket for foreign debris or damage. If debris is found, remove the debris.
3. If error recurs, or socket damage is found, replace the system board.

**Related links**

- “Removing a microprocessor and heat sink” on page 876
- “Installing a microprocessor and heat sink” on page 880
- “Removing and replacing the base assembly” on page 863

- **W.11004 [W.11004] A processor within the system has failed the BIST. : Processor Self Test Failure Detected**

**Severity**

Warning

**User Response**

Complete the following steps:

1. If the processor or firmware was just updated, check the IBM support site for an applicable service bulletin or firmware update that applies to this processor error.
2. If there are multiple Processors, swap Processors to move affected processor to another processor socket and retry. If problem follows the affected processor, or this is a single processor system, replace the processor. Inspect the processor socket on each processor removal and replace system board first if the processor socket is damaged or mis-aligned pins are found.
3. Replace the system board.

**Related links**

- “Removing a microprocessor and heat sink” on page 876
- “Installing a microprocessor and heat sink” on page 880
- “Removing and replacing the base assembly” on page 863

- **W.3048006 [W.3048006] UEFI has booted from the backup flash bank due to an Automatic Boot Recovery (ABR) event. : Automated Boot Recovery, Booting Backup UEFI Image**

**Severity**

Warning

**User Response**

Complete the following steps:

1. Check the IBM support site for an applicable service bulletin or firmware update that applies to this error.
2. Update the primary UEFI image.
3. Replace the system board.

**Related links**

- “Updating firmware and device drivers” on page 23
- “Removing and replacing the base assembly” on page 863

- **W.305000A [W.305000A] An invalid date and time have been detected. : RTC Date and Time Incorrect**

**Severity**

Warning

**User Response**

Complete the following steps:

1. Check IMM/chassis event log. This event should immediately precede 0068002 error. Resolve that event or any other battery related errors.
2. Use F1 Setup to reset date and time. If problem returns after a system reset, replace CMOS battery.
3. If problem persists then check the IBM support site for an applicable service bulletin or firmware update that applies to this error.
4. Replace the system board.

**Related links**

- “Removing the CMOS battery” on page 834
  - “Installing the CMOS battery” on page 835
  - “Updating firmware and device drivers” on page 23
  - “Using the Setup utility” on page 26
  - “Removing and replacing the base assembly” on page 863
- **W.3058009 [W.3058009] DRIVER HEALTH PROTOCOL: Missing Configuraiton. Requires Change Settings From F1. : DRIVER HEALTH PROTOCOL: Missing Configuration. Requires Change Settings From F1**

**Severity**

Warning

**User Response**

Complete the following steps:

1. Go to the Setup Utility (System Settings -> Settings -> Driver Health Status List) and find a driver/controller reporting Configuration Required status.
2. Search for the driver menu from System Settings and change settings appropriately.
3. Save settings and restart system.

**Related links**

- “Using the Setup utility” on page 26
- **W.305800A [W.305800A] DRIVER HEALTH PROTOCOL: Reports 'Failed' Status Controller. : DRIVER HEALTH PROTOCOL: Reports 'Failed' Status Controller**

**Severity**

Warning

**User Response**

Complete the following steps:

1. Reboot the system.
2. If problem persists, switch to backup UEFI or update the current UEFI image.
3. Replace the system board.

**Related links**

- “Updating firmware and device drivers” on page 23
  - “Removing and replacing the base assembly” on page 863
- **W.305800B [W.305800B] DRIVER HEALTH PROTOCOL: Reports 'Reboot' Required Controller. : DRIVER HEALTH PROTOCOL: Reports 'Reboot' Required Controller**

**Severity**

Warning

#### User Response

Complete the following steps:

1. No action required. The system will reboot at the end of POST.
2. If the problem persists, switch to the backup UEFI image or update the current UEFI image.
3. Replace the system board.

#### Related links

- "Updating firmware and device drivers" on page 23
- "Removing and replacing the base assembly" on page 863
- **W.305800C [W.305800C] DRIVER HEALTH PROTOCOL: Reports 'System Shutdown' Required Controller. : DRIVER HEALTH PROTOCOL: Reports 'System Shutdown' Required Controller**

#### Severity

Warning

#### User Response

Complete the following steps:

1. Reboot the system.
2. If problem persists, switch to the backup UEFI image or update the current UEFI image.
3. Replace system board.

#### Related links

- "Updating firmware and device drivers" on page 23
- "Removing and replacing the base assembly" on page 863
- **W.305800D [W.305800D] DRIVER HEALTH PROTOCOL: Disconnect Controller Failed. Requires 'Reboot'. : DRIVER HEALTH PROTOCOL: Disconnect Controller Failed. Requires 'Reboot'**

#### Severity

Warning

#### User Response

Complete the following steps:

1. Reboot the system to reconnect the controller.
2. If problem persists, switch to the backup UEFI image or update the current UEFI image.
3. Replace the system board.

#### Related links

- "Updating firmware and device drivers" on page 23
- "Removing and replacing the base assembly" on page 863
- **W.305800E [W.305800E] DRIVER HEALTH PROTOCOL: Reports Invalid Health Status Driver. : DRIVER HEALTH PROTOCOL: Reports Invalid Health Status Driver**

#### Severity

Warning

#### User Response

Complete the following steps:

1. Reboot the system.
2. If problem persists, switch to the backup UEFI image or update the current UEFI image.
3. Replace the system board.

#### Related links

- "Updating firmware and device drivers" on page 23

- “Removing and replacing the base assembly” on page 863
- **W.3808000 [W.3808000] An IMM communication failure has occurred. : IMM Communication Failure**

**Severity**

Warning

**User Response**

Complete the following steps:

1. Reset the IMM from the CMM.
2. Use the CMM to remove auxilliary power from the compute node. This will reboot the compute node.
3. Check the IBM support site for an applicable service bulletin or firmware update that applies to this error.
4. Update the UEFI Firmware.
5. Replace the system board.

**Related links**

- “Updating firmware and device drivers” on page 23
- “Removing and replacing the base assembly” on page 863
- **W.3808002 [W.3808002] An error occurred while saving UEFI settings to the IMM. : Error Updating System Configuration to IMM**

**Severity**

Warning

**User Response**

Complete the following steps:

1. Use the Setup Utility to verify and save the settings (which will recover the settings).
2. Reset the IMM from the CMM.
3. Use CMM to remove auxilliary power from the compute node. This will reboot the compute node.
4. Check the IBM support site for an applicable service bulletin or firmware update that applies to this error.
5. Update the IMM Firmware.
6. Remove and re-install CMOS battery for 30 seconds to clear CMOS contents.
7. Replace the system board.

**Related links**

- “Removing the CMOS battery” on page 834
- “Installing the CMOS battery” on page 835
- “Updating firmware and device drivers” on page 23
- “Removing and replacing the base assembly” on page 863
- **W.3808003 [W.3808003] Unable to retrieve the system configuration from the IMM. : Error Retrieving System Configuration from IMM**

**Severity**

Warning

**User Response**

Complete the following steps:

1. Use the Setup Utility to verify and save the settings (which will recover the settings).
2. Reset the IMM from the CMM.

3. Use CMM to remove auxilliary power from the compute node. This will reboot the compute node.
4. Check the IBM support site for an applicable service bulletin or firmware update that applies to this error.
5. Update the IMM Firmware.
6. Remove and re-install CMOS battery for 30 seconds to clear CMOS contents.
7. Replace the system board.

#### Related links

- "Removing the CMOS battery" on page 834
- "Installing the CMOS battery" on page 835
- "Updating firmware and device drivers" on page 23
- "Using the Setup utility" on page 26
- "Removing and replacing the base assembly" on page 863
- **W.3818005 [W.3818005] The CRTM flash driver could not successfully flash the staging area. The update was aborted : CRTM Update Aborted**

#### Severity

Warning

#### User Response

Complete the following steps:

1. Continue booting system. If system does not reset, manually reset the system.
2. If the error is not reported on the subsequent boot, no additional recovery action is required.
3. If the event persists, continue booting system and update the UEFI image.
4. Replace the system board.

#### Related links

- "Updating firmware and device drivers" on page 23
- "Removing and replacing the base assembly" on page 863
- **W.3868001 [W.3868001] BOFM: Reset loop avoided - Multiple resets not allowed. : BOFM: Reset loop avoided - Multiple resets not allowed**

#### Severity

Warning

#### User Response

Complete the following steps:

1. Update all firmware (including adapter firmware) to the latest levels.
2. If problem persists, contact Support.

#### Related links

- "Updating firmware and device drivers" on page 23
- **W.3868002 [W.3868002] BOFM: Error communicating with the IMM - BOFM may not be deployed correctly. : BOFM: Error communicating with the IMM - BOFM may not be deployed correctly**

#### Severity

Warning

#### User Response

Complete the following steps:

1. Update all firmware (including adapter firmware) to the latest levels.
2. If problem persists, contact Support.



### Related links

- "Updating firmware and device drivers" on page 23
- "Removing and replacing the base assembly" on page 863

- **W.3938002 [W.3938002] A boot configuration error has been detected. : Boot Configuration Error**

### Severity

Warning

### User Response

Complete the following steps:

1. F1 Setup -> Save Settings.
2. Retry the configuration update.

### Related links

- "Using the Setup utility" on page 26

- **W.50001 [W.50001] A DIMM has been disabled due to an error detected during POST. : DIMM Disabled**

### Severity

Warning

### User Response

Complete the following steps:

1. If the DIMM was disabled because of a memory fault, follow the procedure for that event.
2. If no memory fault is recorded in the logs and no DIMM connector error LEDs are lit, re-enable the DIMM through the Setup utility or the Advanced Settings Utility (ASU).
3. If the problem persists, Power cycle the compute node from the management console.
4. Reset the IMM to default settings.
5. Reset UEFI to default settings.
6. Update IMM and UEFI firmware.
7. Replace the system board.

### Related links

- "Updating firmware and device drivers" on page 23
- "Removing and replacing the base assembly" on page 863

- **W.58001 [W.58001] The PFA Threshold limit (correctable error logging limit) has been exceeded on DIMM number % at address %. MC5 Status contains % and MC5 Misc contains %. : DIMM PFA Threshold Exceeded**

### Severity

Warning

### User Response

Complete the following steps:

1. Prior to replacing memory DIMM, refer to TIP H212154 for minimum code level.
2. If the compute node has recently been installed, moved, serviced, or upgraded, verify that the DIMM is properly seated and visually verify that there is no foreign material in any DIMM connector on that memory channel. If either of these conditions is found, correct and retry with the same DIMM. (Note: The event Log might contain a recent 00580A4 event denoting detected change in DIMM population that could be related to this problem.)
3. Check the IBM support site for an applicable firmware update that applies to this memory error. The release notes will list the known problems the update addresses.

4. If the previous steps do not resolve the problem, at the next maintenance opportunity, replace the affected DIMM (as indicated by LightPath and/or failure log entry).
5. If PFA re-occurs on the same DIMM connector, swap the other DIMMs on the same memory channel one at a time to a different memory channel or processor. If PFA follows a moved DIMM to any DIMM connector on the different memory channel, replace the moved DIMM.
6. Check the IBM support site for an applicable Service Bulletins (Service bulletins) that applies to this memory error. (Link to IBM support service bulletins)
7. If problem continues to re-occur on the same DIMM connector, inspect DIMM connector for foreign material and remove, if found. If connector is damaged, replace system board.
8. Remove the affected processor and inspect the processor socket pins for damaged or mis-aligned pins. If damage is found or the processor is an upgrade part, replace the system board.
9. Replace affected processor.
10. Replace the system board.

#### Related links

- "Removing a DIMM" on page 839
  - "Installing a DIMM " on page 840
  - "Removing a microprocessor and heat sink" on page 876
  - "Installing a microprocessor and heat sink" on page 880
  - "Removing and replacing the base assembly" on page 863
- **W.58007 [W.58007] Invalid memory configuration (Unsupported DIMM Population) detected. Please verify memory configuration is valid. : Unsupported DIMM Population**

#### Severity

Warning

#### User Response

Complete the following steps:

1. This event could follow an uncorrectable memory error or failed memory test. Check the log and resolve that event first. DIMMs disabled by other errors or actions could cause this event.
2. Ensure that the DIMM connectors are populated in the correct sequence.

#### Related links

- "Removing a DIMM" on page 839
  - "Installing a DIMM " on page 840
- **W.580A1 [W.580A1] Invalid memory configuration for Mirror Mode. Please correct memory configuration. : Unsupported DIMM Population for Mirror Mode**

#### Severity

Warning

#### User Response

Complete the following steps:

1. If a DIMM connector error LED is lit, resolve the failure.
2. Make sure that the DIMM connectors are correctly populated for mirroring mode.

#### Related links

- "Removing a DIMM" on page 839
  - "Installing a DIMM " on page 840
- **W.580A2 [W.580A2] Invalid memory configuration for Sparing Mode. Please correct memory configuration. : Unsupported DIMM Population for Spare Mode**

#### Severity

Warning

### User Response

Complete the following steps:

Make sure that the DIMM connectors are correctly populated for sparing mode.

### Related links

- “Removing a DIMM” on page 839
- “Installing a DIMM ” on page 840

- **W.68002 [W.68002] A CMOS battery error has been detected : CMOS Battery Fault**

### Severity

Warning

### User Response

Complete the following steps:

1. If the system was recently installed, moved, or serviced, make sure the battery is properly seated.
2. Check the IBM support site for an applicable service bulletin or firmware update that applies to this error.
3. Replace the CMOS battery
4. Replace the system board.

### Related links

- “Removing the CMOS battery” on page 834
- “Installing the CMOS battery” on page 835
- “Removing and replacing the base assembly” on page 863

---

## Troubleshooting by symptom

Use this information to find solutions to problems that have identifiable symptoms.

To use the symptom-based troubleshooting tables in this section, complete the following steps:

1. Check the IMM event log and follow the suggested actions to resolve any event codes (see “IMM event log” on page 63).
2. Find the symptoms that you are experiencing in the troubleshooting tables in this section and follow the suggested actions to resolve any problems.
3. If the problem remains, submit a service request (see [http://pic.dhe.ibm.com/infocenter/flexsys/information/index.jsp?topic=%2Fcom.ibm.acc.common.nav.doc%2Fkh9\\_r\\_getting\\_help\\_and\\_technical\\_assistance.html](http://pic.dhe.ibm.com/infocenter/flexsys/information/index.jsp?topic=%2Fcom.ibm.acc.common.nav.doc%2Fkh9_r_getting_help_and_technical_assistance.html)).

## Compute node start problems

Use this information to solve compute node start problems.

Follow the suggested actions in the order in which they are listed in the Action column until the problem is solved.

Follow the suggested actions in the order in which they are listed in the Action column until the problem is solved. See Chapter 5 “Parts listing, Types 7167 and 2590” on page 51 to determine which components are Tier 1 customer replaceable units (CRUs) and which components are Tier 2 customer replaceable units (CRUs).

| Symptom                                     | Action   |
|---|--|
| Embedded hypervisor is not in the boot list | <ol style="list-style-type: none"> <li>1. If the compute node has recently been installed, moved, or serviced, or if this is the first time the embedded hypervisor is being used, make sure that the device is connected properly and that there is no physical damage to the connectors.</li> <li>2. Go to <a href="http://www.lenovo.com/serverproven/">http://www.lenovo.com/serverproven/</a> to validate that the embedded hypervisor device is supported for the compute node.</li> <li>3. Use the Setup utility to make sure that the embedded hypervisor device (USB key) is in the startup sequence. From the Setup utility, select <b>Start Options</b>.</li> <li>4. Check <a href="http://www.ibm.com">http://www.ibm.com</a> for any service bulletins related to the embedded hypervisor and the compute node.</li> <li>5. Make sure that other software works on the compute node to ensure that the compute node is working properly.</li> </ol> |

## Connectivity problems

Use this information to solve connectivity problems.

### Cannot communicate with the Flex System Manager management node

Use the information in this section to troubleshoot the compute node when you cannot communicate with the Flex System Manager management node on the data network.

Complete the following steps until the problem is solved:

1. Make sure that all ports for the connection path are enabled and that you can ping the Flex System Manager management node. If you are unable to ping the Flex System Manager management node, see “Cannot ping the Flex System Manager management node on the data network” on page 807.
2. Make sure that the protocols you are using are enabled.

**Note:** By default, only secure protocols are enabled, for example, SSH and HTTPS.

3. If you cannot log into the Flex System Manager management node, see “Cannot log in to the Flex System Manager management node” on page 803.

### Cannot communicate with the CMM

Use the information in this section to troubleshoot the compute node when you cannot communicate with the CMM.

#### Action

**Note:** Communications errors from compute nodes can take up to 20 minutes to appear in the CMM event log.

Complete the following steps until the problem is solved:

1. Make sure that the protocols that you are using are enabled.

**Note:** By default, only secure protocols, such as, SSH and HTTPS, are enabled.

2. Use a serial cable to connect to the I/O module to further isolate the problem.
3. Reset the CMM to the default settings by pressing the reset button on the CMM.

## Cannot communicate with the I/O module

Use the information in this section to troubleshoot the compute node when you cannot communicate with the I/O module.

### Action

Complete the following steps until the problem is solved:

1. Make sure that the protocols that you are using are enabled.

**Note:** By default, only secure protocols, such as, SSH and HTTPS, are enabled.

2. Use a serial cable to connect to the I/O module to further isolate the problem.

## One or more compute nodes are unable to communicate with SAN

Use the information in this section to troubleshoot one or more compute nodes are unable to communicate with SAN.

- Make sure that:
  1. The I/O module is powered on and the appropriate ports are enabled on the I/O module.
  2. The CMM has reported that the I/O module has completed POST and that no errors have been reported in the logs.
  3. The SAN device is powered on and is functional.
  4. All cables between the I/O module and the SAN device are properly connected and secure and that the activity LEDs are lit on the applicable ports.
- See the documentation for the I/O module for additional information about troubleshooting SAN connectivity or network connectivity issues.

Complete the following steps until the problem is solved:

## Cannot connect during initial setup

Use the information in this section to troubleshoot the compute node when you cannot connect during initial setup.

### One compute node is unable to connect during the initial setup

Use the information in this section to troubleshoot one compute node that is unable to connect during the initial setup.

Complete the following steps until the problem is solved:

1. Make sure that:
  - a. The I/O module is powered on and the applicable ports are enabled on the I/O module.
  - b. All cables between the I/O module and the network device (switch or router) are properly connected and secure and that the activity LEDs are lit on the applicable ports.
2. From the compute node operating system, verify the network settings, such as IP address, subnet mask (if you are using IPv4), DHCP settings, and vLAN settings, to ensure that the settings match the settings of the network device. See the documentation for the operating system for information about checking network settings.
3. From the compute node operating system, make sure that the network device is active. See the documentation for the operating system for information about viewing network devices.
4. Check the Support website for any firmware updates that might apply to this issue. You can view the release notes for a firmware update to determine the issues that are addressed by the update.

5. Remove the compute node from the chassis and check the connectors at the back of the node for bent pins. If the pins are bent, contact Support. See “Removing a compute node from a chassis” on page 828.
6. Install the compute node in another compute node bay to see whether the problem remains. See “Installing a compute node in a chassis” on page 829. If the problem persists, make sure that this compute node is connected to a port that has been enabled and that the vLAN settings enable that port to connect to the network.
7. Check <http://www.ibm.com> for any service bulletins that are related to network connectivity.
8. (Trained service technician only) Complete the following steps:
  - a. Force the link/duplex speed.
  - b. Check the connectors on the I/O module to ensure that there are no bent pins.
  - c. Check the connectors on the chassis midplane to ensure there are no bent pins. See the .
  - d. Remove the I/O module and install a working I/O module in the same I/O bay.
  - e. If the problem is solved, replace the I/O module that you removed.
  - f. If the problem remains, replace the chassis midplane.

### **One compute node experiences a sudden loss of connectivity**

Use the information in this section to troubleshoot one compute node that experiences a sudden loss of connectivity.

The event is logged in the event log. See the event log for the management node (if available) or see the event log of the CMM to determine what actions might be required to resolve this issue. See “IMM event log” on page 63.

### **Two or more compute nodes are unable to communicate during initial setup**

Use the information in this section to troubleshoot two or more compute nodes that are unable to communicate during initial setup.

Complete the following steps until the problem is solved:

1. If you have just updated the firmware for one or more devices in the chassis (such as an I/O module or CMM), install the previous level of firmware.
2. Make sure that:
  - a. The I/O module is powered on and the applicable ports are enabled on the I/O module.
  - b. All cables between the I/O module and the network device (switch or router) are properly connected and secure and that the activity LEDs are lit on the applicable ports.
3. From the compute node operating system, verify the network settings, such as IP address, subnet mask (if you are using IPv4), DHCP settings, and vLAN settings, to ensure that the settings match the settings of the network device. See the documentation for the operating system for information about checking network settings.
4. From the compute node operating system, make sure that the network device is active. See the documentation for the operating system for information about viewing network devices.
5. Check <http://www.ibm.com> for any firmware updates that might apply to this issue. You can view the release notes for a firmware update to determine the issues that are addressed by the update.
6. Check the Support website for any service bulletins that are related to network connectivity.
7. (Trained service technician only) Complete the following steps:
  - a. Force the link/duplex speed.
  - b. Check the connectors on the I/O module to ensure that there are no bent pins.

- c. Check the connectors on the chassis midplane to ensure there are no bent pins. See the .
- d. Remove the I/O module and install a working I/O module in the same I/O bay.
- e. If the problem is solved, replace the I/O module that you removed.
- f. If the problem persists, replace the chassis midplane.

### **Two or more compute nodes experience a sudden loss of connectivity**

Use the information in this section to troubleshoot two or more compute nodes that experience a sudden loss of connectivity.

The event is logged in the event log. See the event log for the management node (if available) or see the event log of the CMM to determine what actions might be required to resolve this issue. See “IMM event log” on page 63.

### **Cannot log in**

Use the information in this section to troubleshoot the compute node when you cannot log in to the management node, the CMM, or the I/O module.

#### **Cannot log in to the Flex System Manager management node**

Use the information in this section to troubleshoot the compute node when you cannot log in to the management node.

#### **Action**

Complete the following steps until the problem is solved:

1. Make sure that you are using the correct password and that the capitals lock is off.
2. Contact Support for further assistance if you have forgotten the password.

For additional information about Login problems, see [Login problems at http://pic.dhe.ibm.com/infocenter/flexsys/information/index.jsp?topic=%2Fcom.ibm.acc.8731.doc%2Ftroubleshooting\\_web\\_interface\\_problems.html](http://pic.dhe.ibm.com/infocenter/flexsys/information/index.jsp?topic=%2Fcom.ibm.acc.8731.doc%2Ftroubleshooting_web_interface_problems.html).

#### **Cannot log in to the CMM**

Use the information in this section to troubleshoot the compute node when you cannot log in to the CMM.

#### **Action**

Complete the following steps until the problem is solved:

1. Make sure that you are using the correct password and that the capitals lock is off.
2. Restore the CMM default settings by pressing the reset button on the CMM.

#### **Cannot log in to the I/O module**

Use the information in this section to troubleshoot the compute node when you cannot log in to the I/O module.

#### **Action**

Complete the following steps until the problem is solved:

1. Make sure that you are using the correct password and that the capitals lock is off.
2. Contact Support for further assistance if you have forgotten the password.

### **Cannot ping the CMM on the management network**

Use the information in this section to troubleshoot the compute node when one or more compute nodes cannot ping the CMM on the management network.

### Single node cannot ping the CMM in the same chassis

Use the information in this section to troubleshoot a single compute node that cannot ping the CMM on the management network in the same chassis.

#### Action

Complete the following steps until the problem is solved:

1. Make sure that the Chassis Management Module is powered on and the applicable ports are enabled on the CMM.
2. Make sure that the compute node IMM has acquired an IP address from the CMM by using the Setup utility on the node.

**Note:** If the CMM recently lost connection to the DHCP server, you must reset the IMM by using the CMM interface so that a new IP address can be acquired.

3. In the CMM user interface, click **Chassis Management > Component IP Configuration** and make sure that the IP address that is listed is the same as the IP address that is displayed in the Setup utility. If it is not the same IP address, configure the IMM network settings correctly or reset the IMM to automatically acquire a new IP address.
4. Check <http://www.lenovo.com/support> for any firmware updates that might apply to this problem. You can view the release notes for a firmware update to determine the issues that the update addresses.
5. Remove the compute node from the chassis and check the connectors on the back of the node for bent pins. If the pins are bent, contact Support.
6. Install the compute node in another node bay to determine whether the problem remains. If the problem remains, make sure that the compute node is connected to a port that has been enabled and that the vLAN settings allow that port to connect to the network.
7. Check <http://www.lenovo.com/support> for any service bulletins that are related to network connectivity.
8. (Trained service technician only) Complete the following steps:
  - a. Force the link/duplex speed.
  - b. Check the connectors on the I/O module to make sure that no pins are bent.
  - c. Check the connectors on the chassis midplane to make sure that no pins are bent.
  - d. Remove the CMM and install a working CMM in the same bay.
    - If the problem is solved, replace the CMM that you removed.
    - If the problem remains, replace the chassis midplane.

### Multiple nodes cannot ping the CMM in the same chassis

Use the information in this section to troubleshoot multiple nodes that cannot ping the CMM on the management network in the same chassis.

#### Action

Complete the following steps until the problem is solved:

1. Make sure that the Chassis Management Module is powered on and the applicable ports are enabled on the CMM. If the CMM is hung, reset the CMM.
2. Reset the CMM.
3. Check for firmware updates for the CMM.
4. Reset the CMM to factory defaults and attempt to discover the nodes again. Allow enough time for the IMM to acquire a network address.
5. Replace the CMM.



6. Make sure that the compute node IMM has acquired an IP address from the CMM by using the Setup utility on the node.  
  
**Note:** If the CMM recently lost connection to the DHCP server, you must reset the IMM by using the CMM interface so that a new IP address can be acquired.
7. In the CMM user interface, click **Chassis Management > Component IP Configuration** and make sure that the IP address that is listed is the same as the IP address that is displayed in the Setup utility. If it is not the same IP address, configure the IMM network settings correctly or reset the IMM to automatically acquire a new IP address.
8. Check <http://www.lenovo.com/support> for any firmware updates that might apply to this problem. You can view the release notes for a firmware update to determine the issues that the update addresses.
9. Remove the compute node from the chassis and check the connectors on the back of the node for bent pins. If the pins are bent, contact Support.
10. Check <http://www.lenovo.com/support> for any service bulletins that are related to network connectivity.
11. (Trained service technician only) Complete the following steps:
  - a. Force the link/duplex speed.
  - b. Check the connectors on the CMM to make sure that no pins are bent.
  - c. Check the connectors on the chassis midplane to make sure that no pins are bent.
  - d. Remove the CMM and install a working CMM in the same bay.
    - If the problem is solved, replace the CMM that you removed.
    - If the problem remains, replace the chassis midplane.

### **CMM cannot ping the CMM in a different chassis**

Use the information in this section to troubleshoot a CMM that cannot ping the CMM in a different chassis.

#### **Action**

Complete the following steps until the problem is solved:

1. Make sure that the Chassis Management Modules are powered on and the applicable ports are enabled.
  - a. If the CMM is powered on and hung, reset the CMM.
  - b. Make sure that the IMM, the management node, and the CMMs are all on the same subnet.
2. Verify that the cables between the CMMs and the top-of-rack switch are correctly connected and that the activity LEDs are lit on the applicable ports.
3. Make sure that the management node has a correct IP address and is on the same subnet as the CMMs.
4. Make sure that the compute node IMM has acquired an IP address from the CMM by using the Setup utility on the node.

**Note:** If the CMM recently lost connection to the DHCP server, you must reset the IMM by using the CMM interface so that a new IP address can be acquired.

5. In the CMM user interface, click **Chassis Management > Component IP Configuration** and make sure that the IP address that is listed is the same as the IP address that is displayed in the Setup utility. If it is not the same IP address, configure the IMM network settings correctly or reset the IMM to automatically acquire a new IP address.
6. Check <http://www.lenovo.com/support> for any firmware updates that might apply to this problem. You can view the release notes for a firmware update to determine the issues that the update addresses.
7. Check <http://www.lenovo.com/support> for any service bulletins that are related to network connectivity.
8. Remove the compute node from the chassis and check the connectors on the back of the node and on the chassis midplane for bent pins. If the pins are bent, contact Support.

9. (Trained service technician only) Complete the following steps:
  - a. Force the link/duplex speed.
  - b. Check the connectors on the nodes and on the chassis midplane to make sure that no pins are bent.
  - c. Replace the I/O expansion card in the management node.
  - d. Replace the management node system-board assembly.
  - e. Replace the management node.

### **Cannot ping the I/O module**

Use the information in this section to troubleshoot the compute node when one or more compute nodes cannot ping the I/O module.

#### **Single node cannot ping the I/O module**

Use the information in this section to troubleshoot a single compute node that cannot ping the I/O module.

#### **Action**

Complete the following steps until the problem is solved:

1. If you have recently updated the firmware for one or more devices in the chassis (I/O module) and have verified the network settings, install the previous level of firmware.
2. Make sure that the I/O module is powered on and the applicable ports are enabled on the I/O module.
3. Make sure that all network cables are correctly connected and that the activity LEDs are lit. If the cables are correctly connected and the LEDs are not lit, replace the cable.
4. Check <http://www.lenovo.com/support> for any firmware updates that might apply to this problem. You can view the release notes for a firmware update to determine the issues that are addressed by the update.
5. Remove the node from the chassis and check the connectors at the back of the node for bent pins. If the pins are bent, go to <http://www.lenovo.com/support> to submit a service request.
6. Install the compute node in another node bay, if one is available. If the problem remains, make sure that the compute node is connected to a port that has been enabled and that the vLAN settings allow that port to connect to the network.
7. Check <http://www.lenovo.com/support> for any service bulletins that are related to I/O-module connectivity.
8. If the problem remains, replace the I/O module, and go to <http://www.lenovo.com/support> to submit a service request.
9. (Trained service technician only) Complete the following steps:
  - a. Force the link/duplex speed.
  - b. Check the connectors on the I/O module to make sure that no pins are bent.
  - c. Check the connectors on the chassis midplane to make sure that no pins are bent.
  - d. Remove the I/O module and install a working I/O module in the same I/O bay.
    - If the problem is solved, replace the I/O module that you removed.
    - If the problem remains, replace the chassis midplane.

#### **Multiple nodes cannot ping the I/O module**

Use the information in this section to troubleshoot multiple nodes that cannot ping the I/O module.

#### **Action**

Complete the following steps until the problem is solved:

1. If you have recently updated the firmware for one or more devices in the chassis (I/O module or CMM), install the previous level of firmware.
2. Make sure that the I/O module is powered on and the applicable ports are enabled on the I/O module.
3. Make sure that all network cables are correctly connected and that the activity LEDs are lit.
4. From the compute node operating system, verify that the network device is active. Check also the network settings, such as IP address, subnet mask (if you are using IPv4), DNS, DHCP settings, and vLAN settings to make sure that the settings match the settings of the network device. See the documentation that comes with the operating system for information about viewing network devices and checking the network settings.
5. Check <http://www.lenovo.com/support> for any firmware updates that might apply to this problem. You can view the release notes for a firmware update to determine the issues that are addressed by the update.
6. Check <http://www.lenovo.com/support> for any service bulletins that are related to network connectivity.
7. (Trained service technician only) Complete the following steps:
  - a. Force the link/duplex speed.
  - b. Check the connectors on the I/O module to make sure that no pins are bent.
  - c. Check the connectors on the chassis midplane to make sure that no pins are bent.
  - d. Remove the I/O module and install a working I/O module in the same I/O bay.
    - If the problem is solved, replace the I/O module that you removed.
    - If the problem remains, replace the chassis midplane.

## **Cannot ping the Flex System Manager management node on the data network**

Use the information in this section to troubleshoot the compute node when one or more compute nodes cannot ping the management node on the data network.

### **Single node cannot ping the management node in the same chassis**

Use the information in this section to troubleshoot a single compute node that cannot ping the Flex System Manager management node in the same chassis on the data network.

#### **Action**

Complete the following steps until the problem is solved:

1. Make sure that the management node is powered on and is not hung, by logging in to the management node. If you are unable to log in from the management network, attempt to log in from the data network. If the management node is powered on and hung, perform a virtual reset of the management node from the CMM.
2. Make sure that the I/O module is powered on and is not hung, by pinging the I/O module from the management node. If the I/O module is powered on and hung, reset the I/O module. Make sure that the correct ports are enabled for the node on the I/O module.
3. Make sure that the compute node is the only one in the chassis that the management node cannot ping. If it is not, follow the steps in “Multiple nodes cannot ping the management node in the same chassis” on page 808.
4. Make sure that the configuration settings in the node are correct and that the port is enabled.
5. Check <http://www.lenovo.com/support> for any firmware updates that might apply to this issue. You can view the release notes for a firmware update to determine the issues that are addressed by the update.
6. Check <http://www.lenovo.com/support> for any service bulletins that are related to network connectivity.
7. Remove the compute node and make sure that the connectors on the chassis midplane and the node are not damaged.

8. (Trained service technician only) Complete the following steps:
  - a. Force the link/duplex speed.
  - b. Check the connectors on the node and the chassis midplane to make sure that no pins are bent.
  - c. Replace the base assembly in the compute node.

### **Single node cannot ping the management node in a different chassis**

Use the information in this section to troubleshoot a single compute node that cannot ping the Flex System Manager management node in a different chassis on the data network.

#### **Action**

Complete the following steps until the problem is solved:

1. Make sure that the management node is powered on and is not hung, by logging in to the management node. If you are unable to log in from the management network, attempt to log in from the data network. If the management node is powered on and hung, perform a virtual reset of the management node from the CMM.
2. Make sure that the I/O module is powered on and is not hung, by pinging the I/O module from the management node. If the I/O module is powered on and hung, reset the I/O module. Make sure that the correct ports are enabled for the node on the I/O module.
3. Make sure that the compute node is the only one in the chassis that the management node cannot ping. If it is not, follow the steps in “Multiple nodes cannot ping the management node in the same chassis” on page 808.
4. Make sure that the IP configuration settings on the node are correct and that the port is enabled.
5. Check <http://www.lenovo.com/support> for any firmware updates that might apply to this issue. You can view the release notes for a firmware update to determine the issues that are addressed by the update.
6. Check <http://www.lenovo.com/support> for any service bulletins that are related to network connectivity.
7. Remove the compute node and make sure that the connectors on the midplane and the node are not damaged.
8. (Trained service technician only) Complete the following steps:
  - a. Force the link/duplex speed.
  - b. Check the connectors on the node and the chassis midplane to make sure that no pins are bent.
  - c. Replace the system-board assembly in the compute node.

### **Multiple nodes cannot ping the management node in the same chassis**

Use the information in this section to troubleshoot multiple nodes that cannot ping the Flex System Manager management node in the same chassis on the data network.

#### **Action**

Complete the following steps until the problem is solved:

1. Make sure that the management node is powered on and is not hung, by logging in to the management node. If you are unable to log in from the management network, attempt to log in from the data network. If the management node is powered on and hung, perform a virtual reset of the management node from the CMM.
2. Make sure that the I/O module is powered on and is not hung, by pinging the I/O module from the management node. If the I/O module is powered on and hung, reset the I/O module. Make sure that the correct ports are enabled for the node on the I/O module.
3. Make sure that the management network port (eth1) is enabled in the management node. Make sure that the port configuration settings are correct for the data network.

4. Make sure that the configuration settings for each node are correct and that the data network ports are enabled.
5. Make sure that the configuration settings in the I/O module are correct and that the applicable ports are enabled for your compute nodes and the management node on the I/O module. If the problem remains, complete the following steps:
  - a. Restart the I/O module.
  - b. Check <http://www.lenovo.com/support> for any firmware updates that might apply to this issue. You can view the release notes for a firmware update to determine the issues that are addressed by the update.
  - c. Perform a virtual reseal of the I/O module.
  - d. Replace the I/O module.
6. Check <http://www.lenovo.com/support> for any service bulletins that are related to network connectivity.
7. Remove the management node and make sure that the connectors on the chassis midplane and the management node are not damaged.
8. (Trained service technician only) Complete the following steps:
  - a. Force the link/duplex speed.
  - b. Check the connectors on the nodes and the chassis midplane to make sure that no pins are bent.
  - c. Replace the I/O expansion card in the management node.
  - d. Replace the system-board assembly in the management node.

### **Multiple nodes cannot ping the management node in a different chassis**

Use the information in this section to troubleshoot multiple nodes that cannot ping the Flex System Manager management node in a different chassis on the data network.

#### **Action**

Complete the following steps until the problem is solved:

1. Make sure that the management node is powered on and is not hung, by logging in to the management node. If you are unable to log in from the management network, attempt to log in from the data network. If the management node is powered on and hung, perform a virtual reseal of the management node from the CMM.
2. Make sure that the I/O module is powered on and is not hung, by pinging the I/O module from the management node. If the I/O module is powered on and hung, reset the I/O module. Make sure that the correct ports are enabled for the node on the I/O module.
3. Make sure that the management network port (eth1) in the management node is enabled. Make sure that the port configuration settings are correct for the data network.
4. Make sure that the configuration settings for each node are correct and that the data network ports are enabled.
5. Make sure that the configuration settings in the I/O module are correct and that the applicable ports are enabled for your compute nodes and the management node on the I/O module. If the problem remains, complete the following steps:
  - a. Restart the I/O module.
  - b. Check <http://www.lenovo.com/support> for any firmware updates that might apply to this issue. You can view the release notes for a firmware update to determine the issues that are addressed by the update.
  - c. Perform a virtual reseal of the I/O module.
  - d. Replace the I/O module.
6. Check <http://www.lenovo.com/support> for any service bulletins that are related to network connectivity.

7. Remove the management node and make sure that the connectors on the chassis midplane and the node are not damaged.
8. (Trained service technician only) Complete the following steps:
  - a. Force the link/duplex speed.
  - b. Check the connectors on the nodes and the chassis midplane to make sure that no pins are bent.
  - c. Replace the I/O expansion card in the management node.
  - d. Replace the system-board assembly in the management node.

### **Multiple nodes cannot ping the management node in the same chassis or a different chassis**

Use the information in this section to troubleshoot multiple nodes that cannot ping the Flex System Manager management node in the same chassis or a different chassis on the data network.

#### **Action**

Complete the following steps until the problem is solved:

1. Follow the steps in “Multiple nodes cannot ping the management node in the same chassis” on page 808.
2. Follow the steps in “Multiple nodes cannot ping the management node in a different chassis” on page 809.

### **Cannot ping the Flex System Manager management node on the management network**

Use the information in this section to troubleshoot the compute node when one or more compute nodes cannot ping the management node on the management network.

#### **Single node cannot ping the management node in the same chassis**

Use the information in this section to troubleshoot a single compute node that cannot ping the Flex System Manager management node in the same chassis on the management network.

#### **Action**

Complete the following steps until the problem is solved:

1. Make sure that the management node is powered on and is not hung, by logging in to the management node. If you are unable to log in from the management network, attempt to log in from the data network. If the management node is powered on and hung, perform a virtual reset of the management node from the CMM.
2. Make sure that the CMM is powered on and is not hung, by pinging the CMM from the management node. If the CMM is powered on and hung, reset the CMM. Make sure that the IMM, the management node, and CMM are all on the same subnet.
3. Make sure that the compute node is the only one in the chassis that the management node cannot ping. If it is not, follow the steps in “Multiple nodes cannot ping the management node in the same chassis” on page 812. Make sure that the compute node appears on the chassis map (it might not be fully discovered by the management node software).
4. Make sure that the system-management processor in each compute node has a valid IP address by checking the chassis map of the remote chassis.

**Note:** If the CMM recently lost connection to the DHCP server, you must reset the IMM by using the CMM interface so that a new IP address can be acquired.

5. In the CMM user interface, click **Chassis Management > Component IP Configuration** and make sure that the IP address that is listed is the same as the IP address that is displayed in the Setup utility. If it is not the same, configure the IMM network settings correctly.

6. Check <http://www.lenovo.com/support> for any firmware updates that might apply to this issue. You can view the release notes for a firmware update to determine the issues that are addressed by the update.
7. Check <http://www.lenovo.com/support> for any service bulletins that are related to network connectivity.
8. Remove the compute node and make sure that the connectors on the chassis midplane and the node are not damaged.
9. (Trained service technician only) Complete the following steps:
  - a. Force the link/duplex speed.
  - b. Check the connectors on the node and the chassis midplane to make sure that no pins are bent.
  - c. Replace the compute node.

### Single node cannot ping the management node in a different chassis

Use the information in this section to troubleshoot a single compute node that cannot ping the Flex System Manager management node in a different chassis on the management network.

#### Action

Complete the following steps until the problem is solved:

1. Make sure that the management node is powered on and is not hung, by logging in to the management node. If you are unable to log in from the management network, attempt to log in from the data network. If the management node is powered on and hung, perform a virtual reset of the management node from the CMM.
2. Make sure that the CMM is powered on and is not hung, by pinging the CMM from the management node:
  - a. If the CMM is powered on and hung, reset the CMM
  - b. Make sure that the IMM, the management node, and CMM are all on the same subnet.
3. Make sure that the compute node is the only one in the chassis that the management node cannot ping. If it is not, follow the steps in “Multiple nodes cannot ping the management node in the same chassis” on page 812. Make sure that the compute node appears on the chassis map (it might not be fully discovered by the management node software).
4. Make sure that the IMM has acquired an IP address from the CMM by using the Setup utility on the compute node.

**Note:** If the CMM recently lost connection to the DHCP server, you must reset the IMM by using the CMM interface so that a new IP address can be acquired.

5. Make sure that the system-management processor in each compute node has a valid IP address by checking the chassis map of the remote chassis.

**Note:** If the CMM recently lost connection to the DHCP server, you must reset the IMM by using the CMM interface so that a new IP address can be acquired.

6. Check <http://www.lenovo.com/support> for any firmware updates that might apply to this issue. You can view the release notes for a firmware update to determine the issues that are addressed by the update.
7. Check <http://www.lenovo.com/support> for any service bulletins that are related to network connectivity.
8. Remove the compute node and make sure that the connectors on the chassis midplane and the node are not damaged.
9. (Trained service technician only) Complete the following steps:
  - a. Check the connectors on the node and the chassis midplane to make sure that no pins are bent.
  - b. Replace the base assembly in the compute node.

### Multiple nodes cannot ping the management node in the same chassis

Use the information in this section to troubleshoot multiple nodes that cannot ping the Flex System Manager management node in the same chassis on the management network.

#### Action

Complete the following steps until the problem is solved:

1. Make sure that the management node is powered on and is not hung, by logging in to the management node. If you are unable to log in from the management network, attempt to log in from the data network. If the management node is powered on and hung, perform a virtual reset of the management node from the CMM.
2. Make sure that the CMM is powered on and is not hung, by pinging the CMM from the management node:
  - a. If the CMM is powered on and hung, reset the CMM.
  - b. Make sure that the IMM, the management node, and CMM are all on the same subnet.
3. Make sure that the management network port (eth0) in the management node is enabled.
4. Make sure that the management node has an IP address, is on the same subnet as the CMM, and is able to ping the CMM.
5. Make sure that the system-management processor in each compute node has a valid IP address by checking the chassis map of the remote chassis.

**Note:** If the CMM recently lost connection to the DHCP server, you must reset the IMM by using the CMM interface so that a new IP address can be acquired.

If a system-management processor does not have a valid IP address, complete the following steps:

- a. Restart the CMM.
  - b. Check <http://www.lenovo.com/support> for any firmware or software updates that might apply to this issue. You can view the release notes for a firmware update to determine the issues that are addressed by the update.
  - c. Remove and reinstall the CMM.
  - d. Replace the CMM.
6. Check <http://www.lenovo.com/support> for any service bulletins that are related to network connectivity.
  7. Remove the management node and make sure that the connectors on the chassis midplane and the management node are not damaged.
  8. (Trained service technician only) Complete the following steps:
    - a. Force the link/duplex speed.
    - b. Check the connectors on the nodes and the chassis midplane to make sure that no pins are bent.
    - c. Replace the I/O expansion card in the management node.
    - d. Replace the system-board assembly in the management node .
    - e. Replace the management node.

### Multiple nodes cannot ping the management node in a different chassis

Use the information in this section to troubleshoot multiple nodes that cannot ping the Flex System Manager management node in a different chassis on the management network.

#### Action

Complete the following steps until the problem is solved:

1. Make sure that the management node is powered on and is not hung, by logging in to the management node. If you are unable to log in from the management network, attempt to log in from the data network.



If the management node is powered on and hung, perform a virtual reset of the management node from the CMM.

2. Make sure that the CMM is powered on and is not hung by pinging the CMM from the management node:
  - a. If the CMM is powered on and hung, reset the CMM.
  - b. Make sure that the IMM, the management node, and the CMM are all on the same subnet.
3. Make sure that all cables between the CMMs and the top-of-rack switch are correctly connected and secure and that the activity LEDs are lit on the applicable ports.
4. Make sure that the CMMs (the CMM in the same chassis as the management node and the CMM in the remote chassis) have the same subnet address and can ping one another. If they cannot, make sure that the ports on the top-of-rack switch are enabled. Attempt to connect the CMMs directly if possible.
5. Make sure that the management node has fully discovered the nodes within its chassis by viewing the chassis map. If it has not fully discovered the nodes, follow the steps in “Multiple nodes cannot ping the management node in the same chassis” on page 812.
6. Make sure that the management processor for each compute node has a valid IP address by checking the chassis map of the remote chassis.

**Note:** If the CMM recently lost connection to the DHCP server, you must reset the IMM by using the CMM interface so that a new IP address can be acquired.

If a system-management processor does not have a valid IP address, complete the following steps:

- a. Restart the CMM in the remote chassis.
  - b. Check <http://www.lenovo.com/support> for any firmware or software updates that might apply to this issue. You can view the release notes for a firmware update to determine the issues that are addressed by the update.
  - c. Remove and reinstall the CMM.
  - d. Replace the CMM.
7. Check <http://www.lenovo.com/support> for any service bulletins that are related to network connectivity.
  8. Remove the node and make sure that the connectors on the chassis midplane and the node are not damaged.
  9. (Trained service technician only) Complete the following steps:
    - a. Force the link/duplex speed.
    - b. Check the connectors on the nodes and the chassis midplane to make sure that no pins are bent.
    - c. Replace the I/O expansion card in the management node.
    - d. Replace the system-board assembly in the management node.

### **Multiple nodes cannot ping the management node in the same chassis or a different chassis**

Use the information in this section to troubleshoot multiple nodes that cannot ping the Flex System Manager management node in the same chassis or a different chassis on the management network.

#### **Action**

Complete the following steps until the problem is solved:

1. Follow the steps in “Multiple nodes cannot ping the management node in the same chassis” on page 812.
2. Follow the steps in “Multiple nodes cannot ping the management node in a different chassis” on page 812.

## Hard disk drive problems

Use this information to resolve hard disk drive problems.

Follow the suggested actions in the order in which they are listed in the Action column until the problem is solved.

| <ul style="list-style-type: none"><li>• Follow the suggested actions in the order in which they are listed in the Action column until the problem is solved.</li><li>• See Chapter 5 “Parts listing, Types 7167 and 2590” on page 51 to determine which components are customer replaceable units (CRU) and which components are field replaceable units (FRU) that must be replaced only by a trained service technician.</li><li>• If an action step is preceded by “(Trained service technician only),” that step must be performed only by a trained service technician.</li></ul> |  |
|--|--|
| Symptom  | Action   |
| Compute node fails to recognize one drive  | <ol style="list-style-type: none"><li>1. Verify that the drive is supported for this compute node. Go to <a href="http://www.lenovo.com/serverproven/">http://www.lenovo.com/serverproven/</a> to see a list of supported hard disk drives.</li><li>2. Make sure that the drive is seated in the drive bay properly and that there is no physical damage to the drive connectors.</li><li>3. Replace the drive (see “Removing a hot-swap hard disk drive” on page 856 and “Installing a hot-swap hard disk drive” on page 856).</li><li>4. If the drive is still not recognized, replace the hard disk drive backplane (see “Removing the hard disk drive backplane” on page 853 and “Installing the hard disk drive backplane” on page 855).</li><li>5. If the problem remains, replace the base assembly (see “Removing and replacing the base assembly” on page 863).</li></ol> |

## Intermittent problems

Use this information to solve intermittent problems.

Follow the suggested actions in the order in which they are listed in the Action column until the problem is solved.

The intermittent problems table is a two-column table that lists the symptoms and corrective actions for intermittent problems. Column 1 lists the symptom. Column 2 describes the corrective actions for each symptom.

| <ul style="list-style-type: none"> <li>• Follow the suggested actions in the order in which they are listed in the Action column until the problem is solved.</li> <li>• See Chapter 5 “Parts listing, Types 7167 and 2590” on page 51 to determine which components are customer replaceable units (CRU) and which components are field replaceable units (FRU) that must be replaced only by a trained service technician.</li> <li>• If an action step is preceded by “(Trained service technician only),” that step must be performed only by a trained service technician.</li> </ul> |  |
|--|--|
| Symptom  | Action   |
| Intermittent external device problems  | <ol style="list-style-type: none"> <li>1. Make sure that the correct device drivers are installed. See the manufacturer's website for documentation.</li> <li>2. For a USB device: <ol style="list-style-type: none"> <li>a. Make sure that the device is configured correctly (see “Using the Setup utility” on page 26).</li> <li>b. Connect the device to another port. If you are using a USB hub, remove the hub and connect the device directly to the compute node. Make sure that the device is configured correctly for the port (see “Using the Setup utility” on page 26).</li> <li>c. Run DSA Preboot USB diagnostics.</li> </ol> </li> </ol>  |
| Intermittent KVM problems  | <p>Video problems:</p> <ol style="list-style-type: none"> <li>1. Make sure that all cables and the console breakout cable are properly connected and secure.</li> <li>2. Make sure that the monitor is working properly by testing it on another compute node.</li> <li>3. Test the console breakout cable on a working compute node to ensure that it is operating properly. Replace the console breakout cable if it is defective.</li> </ol> <p>Keyboard problems:</p> <p>Make sure that all cables and the console breakout cable are properly connected and secure.</p> <p>Mouse problems:</p> <p>Make sure that all cables and the console breakout cable are properly connected and secure.</p> |
| Intermittent unexpected reboots  | <p>Check for an event code that indicates a reboot. See the event log for the management node (if available) or see the CMM event log to determine what actions might be required to resolve this issue. See “IMM event log” on page 63. Some correctable errors require that the compute node reboot so that it can disable a device, such as a DIMM or a microprocessor, to allow the compute node to boot properly.</p>   |

## Intermittent connectivity problems

Use this information to solve intermittent connectivity problems.

Follow the suggested actions in the order in which they are listed in the Action column until the problem is solved.

| <ul style="list-style-type: none"> <li>• Follow the suggested actions in the order in which they are listed in the Action column until the problem is solved.</li> <li>• See Chapter 5 “Parts listing, Types 7167 and 2590” on page 51 to determine which components are customer replaceable units (CRU) and which components are field replaceable units (FRU) that must be replaced only by a trained service technician.</li> <li>• If an action step is preceded by “(Trained service technician only),” that step must be performed only by a trained service technician.</li> </ul> |   |
|--|---|
| Symptom  | Action  |
| Single compute node cannot connect intermittently  | <ol style="list-style-type: none"> <li>1. Make sure that the network cables are correctly connected in the switch module ports and the switch module is correctly seated.</li> <li>2. Update the NIC device driver or the storage device controller device driver.</li> <li>3. See the documentation for the I/O module for resolving connectivity issues.</li> </ol>   |
| Two or more compute nodes cannot connect intermittently  | <ol style="list-style-type: none"> <li>1. Using the diagnostic tools that are provided by the device manufacturer, test the I/O module that the devices are connected to.</li> <li>2. Attempt to connect one compute node to the network first, and connect other compute nodes, one by one, to try to isolate the problem.</li> <li>3. Update the I/O module firmware, if necessary.</li> </ol> <p><b>Note:</b> Restarting the compute node and running POST diagnostics on the I/O module might also help isolate the problem; however, this might have other ramifications to the network.</p>   |
| Compute nodes are not discovered by the Flex System Manager management node or the CMM intermittently  | <ol style="list-style-type: none"> <li>1. Make sure that the compute node is recognized by the Flex System Manager management node or the CMM. It might appear as an unknown device in the chassis map. If it is not recognized, complete the following steps. <ol style="list-style-type: none"> <li>a. Remove the compute node and inspect both the compute node and the back of the compute node bay to ensure that there is no physical damage to connectors.</li> <li>b. Move the compute node to another node bay.</li> <li>c. Replace the compute node.</li> </ol> </li> <li>2. Make sure that the Flex System Manager management node or the CMM can ping the compute nodes. If they cannot, see “Cannot ping the Flex System Manager management node on the management network” on page 810.</li> <li>3. If the compute nodes are in another chassis, make sure that you have the proper software entitlements to manage that chassis with the Flex System Manager management node.</li> <li>4. Check <a href="http://www.lenovo.com/support">http://www.lenovo.com/support</a> for any firmware updates that might apply to this issue. You can view the release notes for a firmware update to determine the issues that are addressed by the update.</li> <li>5. Check <a href="http://www.lenovo.com/support">http://www.lenovo.com/support</a> for any service bulletins that are related to network connectivity.</li> </ol> |

## Memory problems

Use this information to solve memory problems.

Follow the suggested actions in the order in which they are listed in the Action column until the problem is solved.

- Follow the suggested actions in the order in which they are listed in the Action column until the problem is solved.
- See Chapter 5 “Parts listing, Types 7167 and 2590” on page 51 to determine which components are customer replaceable units (CRU) and which components are field replaceable units (FRU) that must be replaced only by a trained service technician.
- If an action step is preceded by “(Trained service technician only),” that step must be performed only by a trained service technician.

| Symptom  | Action  |
|--|---|
| <p>The amount of system memory that is displayed is less than the amount of installed physical memory.</p> | <ol style="list-style-type: none"> <li>1. Make sure that:               <ol style="list-style-type: none"> <li>a. You have installed the correct type of memory (see “Installing a DIMM ” on page 840).</li> <li>b. Memory mirroring or memory sparing mode does not account for the discrepancy. You can check the memory configuration in the Setup utility (see “Using the Setup utility” on page 26).</li> </ol> </li> <li>2. If new memory has recently been installed, make sure that no configuration events are reported in the event log. If there are any events, resolve them.</li> <li>3. If the compute node was recently installed, moved, or serviced, make sure that the DIMMs are correctly seated in the connectors (see “Installing a DIMM ” on page 840).</li> <li>4. Make sure that all DIMMs are enabled. The compute node might have automatically disabled a DIMM when it detected a problem, or a DIMM might have been manually disabled (see “Using the Setup utility” on page 26).</li> <li>5. Run memory diagnostics (see “Lenovo Dynamic System Analysis Preboot diagnostic program ” on page 65).</li> <li>6. Remove DIMMs until the compute node is showing the correct amount of memory. Install one DIMM at a time until you can determine the DIMM that is not working properly. Remove that DIMM and replace it with a good DIMM (see “Removing a DIMM” on page 839, and “Installing a DIMM ” on page 840).</li> </ol> <p><b>Note:</b> After you install or remove a DIMM, you must change and save the new configuration information by using the Setup utility. When you turn on the compute node, a message indicates that the memory configuration has changed. Start the Setup utility and select <b>Save Settings</b> (see “Using the Setup utility” on page 26 for more information) to save changes.</p> <ol style="list-style-type: none"> <li>7. Contact Support.</li> </ol> |

## Observable problems

Use this information to solve observable problems.

Follow the suggested actions in the order in which they are listed in the Action column until the problem is solved.

- Follow the suggested actions in the order in which they are listed in the Action column until the problem is solved.
- See Chapter 5 “Parts listing, Types 7167 and 2590” on page 51 to determine which components are customer replaceable units (CRU) and which components are field replaceable units (FRU) that must be replaced only by a trained service technician.
- If an action step is preceded by “(Trained service technician only),” that step must be performed only by a trained service technician.

| Symptom  | Action   |
|--|--|
| <p>Compute node is unresponsive (POST is complete and operating system is running)</p> | <p>If you are in the same location as the compute node, complete the following steps:</p> <ol style="list-style-type: none"> <li>1. If you are using a KVM connection, make sure that the connection is operating correctly. Otherwise, make sure that the keyboard and mouse are operating correctly.</li> <li>2. If possible, log in to the compute node and verify that all applications are running (no applications are hung).</li> <li>3. Restart the compute node.</li> <li>4. Make sure that any new software has been installed and configured correctly.</li> <li>5. Contact your place of purchase of the software or your software provider.</li> </ol> <p>If you are accessing the compute node from a remote location, complete the following steps:</p> <ol style="list-style-type: none"> <li>1. Make sure that all applications are running (no applications are hung).</li> <li>2. Attempt to log out of the system and log back in.</li> <li>3. Validate the network access by pinging or running a trace route to the compute node from a command line: <ol style="list-style-type: none"> <li>a. If you are unable to get a response during a ping test, attempt to ping another compute node in the chassis to determine whether it is a connection problem or compute node problem.</li> <li>b. Run a trace route to determine where the connection breaks down. Attempt to resolve a connection issue with either the VPN or the point at which the connection breaks down.</li> </ol> </li> <li>4. Restart the compute node remotely through the management interface.</li> <li>5. If the problem remains, verify that any new software has been installed and configured correctly.</li> <li>6. Contact your place of purchase of the software or your software provider.</li> </ol> |
| <p>Unusual smell</p>   | <p>An unusual smell might be coming from newly installed equipment. If the problem remains, contact Support.</p>   |

- Follow the suggested actions in the order in which they are listed in the Action column until the problem is solved.
- See Chapter 5 “Parts listing, Types 7167 and 2590” on page 51 to determine which components are customer replaceable units (CRU) and which components are field replaceable units (FRU) that must be replaced only by a trained service technician.
- If an action step is preceded by “(Trained service technician only),” that step must be performed only by a trained service technician.

| Symptom                              | Action   |
|--------------------------------------|--|
| Compute node seems to be running hot | <p>Multiple compute nodes or chassis:</p> <ol style="list-style-type: none"> <li>1. Make sure that the room temperature is within the specified range (see “Features and specifications” on page 5).</li> <li>2. Check the management node event log (if available) or the CMM event log for rising temperature events. If there are no events, the compute node is running within normal operating temperatures. Note that you can expect some variation in temperature.</li> </ol> <p>Single compute node:</p> <p>Check the management node event log (if available) or the CMM event log for rising temperature events. If there are no events, the compute node is running within normal operating temperatures. Note that you can expect some variation in temperature.</p> |
| Cracked parts or cracked chassis     | Contact Support.   |

## Optional device and FRU installation problems

Use this information to resolve optional device and FRU installation problems.

Follow the suggested actions in the order in which they are listed in the Action column until the problem is solved.

- Follow the suggested actions in the order in which they are listed in the Action column until the problem is solved.
- See Chapter 5 “Parts listing, Types 7167 and 2590” on page 51 to determine which components are customer replaceable units (CRU) and which components are field replaceable units (FRU) that must be replaced only by a trained service technician.
- If an action step is preceded by “(Trained service technician only),” that step must be performed only by a trained service technician.

| Symptom                                      | Action  |
|--|---|
| External USB device not recognized           | <ol style="list-style-type: none"> <li>1. Make sure that the correct device drivers are installed on the compute node. See the product documentation for the USB device for information about device drivers.</li> <li>2. Use the Setup utility to make sure that the device is configured correctly.</li> <li>3. If the USB device is connected to a hub or the console breakout cable, disconnect the device and connect it directly into the USB port on the front of the compute node.</li> <li>4. Run the DSA USB diagnostic tests.</li> </ol>   |
| PCIe adapters not recognized/<br>functioning | <ol style="list-style-type: none"> <li>1. Check the event log and resolve any issues related to the device.</li> <li>2. See <a href="http://www.lenovo.com/serverproven/">http://www.lenovo.com/serverproven/</a> to validate that the adapter is supported.</li> <li>3. Make sure that the adapter is installed in a correct slot.</li> <li>4. Make sure that the correct device drivers are installed for the device.</li> <li>5. Resolve any resource conflicts if running legacy mode (UEFI).</li> <li>6. Check <a href="http://www.lenovo.com/support">http://www.lenovo.com/support</a> for any service bulletins.</li> <li>7. Make sure that any adapter external connections are correct and that the connectors are not physically damaged.</li> </ol> |

## Performance problems

Use this information to solve performance problems.

Follow the suggested actions in the order in which they are listed in the Action column until the problem is solved.



- Follow the suggested actions in the order in which they are listed in the Action column until the problem is solved.
- See Chapter 5 “Parts listing, Types 7167 and 2590” on page 51 to determine which components are customer replaceable units (CRU) and which components are field replaceable units (FRU) that must be replaced only by a trained service technician.
- If an action step is preceded by “(Trained service technician only),” that step must be performed only by a trained service technician.

| Symptom                          | Action   |
|----------------------------------|--|
| Poor or slow network performance | <ol style="list-style-type: none"> <li>1. Isolate which network is operating slowly (such as storage, data, or management). You might find it helpful to use ping tools or operating-system tools such as task manager or resource manager.</li> <li>2. Check for traffic congestion on the network.</li> <li>3. Update the NIC device driver or the storage device controller device driver.</li> <li>4. Use the traffic-diagnostic tools that are provided by the I/O module manufacturer.</li> </ol>  |
| Operating-system performance     | <ol style="list-style-type: none"> <li>1. If you have recently made changes to the compute node (for example, updated device drivers or installed software applications) remove the changes.</li> <li>2. Check for any networking issues.</li> <li>3. Check the operating-system logs for performance-related errors.</li> <li>4. Check for events related to high temperatures and power issues, because the compute node might be throttled to help with cooling. If it is throttled, reduce the workload on the compute node to help improve performance.</li> <li>5. Check for events related to disabled DIMMs. If you do not have enough memory for the application workload, your operating system will have poor performance.</li> <li>6. Ensure that the workload is not too high for the configuration.</li> </ol> |

## Power-on problems

Use this information to resolve power-on problems.

Follow the suggested actions in the order in which they are listed in the Action column until the problem is solved.

- Follow the suggested actions in the order in which they are listed in the Action column until the problem is solved.
- See Chapter 5 “Parts listing, Types 7167 and 2590” on page 51 to determine which components are customer replaceable units (CRU) and which components are field replaceable units (FRU) that must be replaced only by a trained service technician.
- If an action step is preceded by “(Trained service technician only),” that step must be performed only by a trained service technician.

| Symptom                         | Action  |
|---------------------------------|---|
| Single node does not power on   | <ol style="list-style-type: none"> <li>1. Check the event logs for any events that are related to the compute node, and solve them. If a management node is available, check the event log on the management node. Otherwise, the Chassis Management Module event log.</li> <li>2. Make sure that the CMM can recognize the compute node. Log in to the CMM user interface and verify that the compute node appears in the chassis view. If the CMM cannot recognize the compute node, remove the compute node and inspect the compute node and the back of the node bay to make sure that there is no physical damage to the connectors.</li> <li>3. Make sure that the power policy that is implemented on the CMM is sufficient to enable the compute node to power on. You can view the power policy from the CMM user interface (click <b>Power Management &gt; Power Modules and Management</b>).</li> <li>4. Make sure that the management node has completed the discovery of the compute node. Log in to the management node user interface and verify that the compute node appears in the list of manageable systems.</li> <li>5. Replace the compute node.</li> </ol> <p><b>Note:</b> Until you are able to replace the compute node, you can attempt to power on the compute node from the CMM or from the management node user interface.</p> |
| Multiple nodes do not power on  | Check the event logs for any events that are related to the compute nodes, and solve them. If a management node is available, check the event log on the management node. Otherwise, check the Chassis Management Module event log.   |
| Compute node does not power off | <ol style="list-style-type: none"> <li>1. Attempt to power off the compute node through the management node user interface, if a management node is available. Otherwise, attempt to power off the compute node through the CMM user interface.</li> <li>2. Attempt to restart the system-management processor for the compute node. You can restart the system-management processor through the CMM user interface. Click the compute node in the chassis view and then click <b>Restart System Mgmt Processor</b>. After the system-management processor has been restarted, attempt to power off the compute node from the CMM.</li> <li>3. Attempt to power off the compute node by using the power button on the front of the node.</li> <li>4. Attempt to reset the compute node from the CMM command-line interface (CLI) by using the <b>reset</b> command.</li> <li>5. Reseat the CMM; then, perform steps 1-4 again.</li> </ol>   |

### Single node does not power on

Complete the following steps until the problem is solved.

1. If you recently installed, moved, or serviced the computer node, reseat the compute node in the bay. If the compute node was not recently installed, moved, or serviced, perform a virtual reseat through the CMM **service** command. For more information about the CMM **service** command, see the .

2. Check the event logs for any events that are related to the compute node, and solve them. If a management node is available, check the event log on the management node. Otherwise, check the event log on the Chassis Management Module.
3. Make sure that the CMM can recognize the compute node. Log in to the CMM user interface and verify that the compute node appears in the chassis view. If the CMM cannot recognize the compute node, remove the compute node and inspect the compute node and the back of the node bay to make sure there is no physical damage to the connectors.
4. Make sure that the power policy that is implemented on the CMM is sufficient to enable the compute node to power on. You can view the power policy from the CMM **pmpolicy** command and the CMM web interface.
  - For more information about the CMM **pmpolicy** command, see the .
  - From the CMM web interface, select **Power Modules and Management** from the Chassis Management menu. For more information, see the . All fields and options are described in the CMM web interface online help.
5. Make sure that the management node has completed the discovery of the compute node. Log in to the management node user interface and verify that the compute node appears in the list of manageable systems.
6. Replace the base assembly (see “Removing and replacing the base assembly” on page 863).

**Note:** Until you are able to replace the system-board assembly, you can attempt to power on the compute node from the CMM or from the management node user interface.

For additional information, see [UEFI Compliant Firmware on System x® and BladeCenter® Servers](#) and the [Flex System Quick start guides](#).

## Multiple nodes do not power on

Complete the following steps until the problem is solved.

1. If you recently installed, moved, or serviced the computer nodes, reseal the compute nodes in the bays. If the compute nodes were not recently installed, moved, or serviced, perform a virtual reseal through the CMM **service** command. For more information about the CMM **service** command, see the .
2. Check the event logs for any events that are related to the compute nodes, and solve them. If a management node is available, check the event log on the management node. Otherwise, check the event log on the Chassis Management Module.

## Compute node does not power off

Complete the following steps until the problem is solved.

1. Attempt to power off the compute node through the management node user interface, if a management node is available. Otherwise, attempt to power off the compute node through the CMM user interface.
2. Attempt to restart the system-management processor for the compute node. You can restart the system-management processor through the CMM user interface. Click the compute node in the chassis view and then click **Restart System Mgmt Processor**. After the system-management processor has been restarted, attempt to power off the compute node from the CMM.
3. Attempt to power off the compute node by using the power button on the front of the node.
4. Attempt to reset the compute node from the CMM command-line interface (CLI) by using the **reset** command.
5. Reseat the CMM; then, perform steps 1-5 again.

## Software problems

Use this information to solve software problems.

Complete the following steps until the problem is solved:

1. To determine whether the problem is caused by the software, make sure that:
  - The compute node has the minimum memory that is needed to use the software. For memory requirements, see the information that comes with the software.

**Note:** If you have just installed an adapter or memory, the compute node might have a memory-address conflict.

  - The software is designed to operate on the compute node.
  - Other software works on the compute node.
  - The software works on another compute node.
2. If you receive any error messages while you use the software, see the information that comes with the software for a description of the messages and suggested solutions to the problem.
3. Contact your place of purchase of the software.

---

## Solving undetermined problems

Use this information to solve undetermined problems.

**Notes:** When you are diagnosing a problem in the compute node, you must determine whether the problem is in the compute node or in the Flex System chassis.

- If all of the compute nodes have the same symptom, the problem is probably in the Flex System chassis. For more information, see the documentation for your Flex System chassis.
- If the Flex System chassis contains more than one compute node and only one of the compute nodes has the problem, troubleshoot the compute node that has the problem.

If DSA did not diagnose the failure or if the compute node is inoperative, use the information in this section.

If you suspect that a software problem is causing failures (continuous or intermittent), see “Software problems” on page 824.

Corrupted data in CMOS memory or corrupted UEFI code can cause undetermined problems. To reset the CMOS data, remove and replace the CMOS battery to override the power-on password and clear the CMOS memory; see “Removing the CMOS battery” on page 834. If you suspect that the UEFI code is corrupted, see “Recovering a UEFI image” on page 24.

Check the LEDs on all the power supplies of the Flex System chassis in which the compute node is installed. If the LEDs indicate that the power supplies are working correctly and reseating the compute node does not correct the problem, complete the following steps:

1. If no LEDs on the control panel are working, try to turn on the compute node from the Chassis Management Module (see the documentation for the Flex System chassis and Chassis Management Module for more information).
2. Turn off the compute node.
3. Remove the compute node from the Flex System chassis and remove the cover.
4. Remove or disconnect the following devices, one at a time, until you find the failure. Reinstall, turn on, and reconfigure the compute node each time.
  - I/O expansion adapter.
  - Hard disk drives.
  - DIMMs. The minimum configuration requirement is 4 GB (one 4 GB DIMM on the system board).The following minimum configuration is required for the compute node to start:

- Base assembly
  - One microprocessor
  - One 4 GB DIMM
  - A functioning Flex System chassis
5. Install and turn on the compute node. If the problem remains, suspect the following components in the following order:
    - a. DIMM
    - b. Base assembly
    - c. Microprocessor

If the problem is solved when you remove an I/O expansion adapter from the compute node but the problem recurs when you reinstall the same adapter, suspect the I/O expansion adapter; if the problem recurs when you replace the adapter with a different one, suspect the system-board assembly.

If you suspect a networking problem and the compute node passes all the system tests, suspect a network cabling problem that is external to the system.

---

## Collecting service data

The first-failure data capture (FFDA) tool monitors, tracks, and captures system hardware errors and hardware and software inventory information, and reports serviceable problems directly to Support. You can also choose to collect data manually. This tool is integrated into the IMM2. All information sent is encrypted and stored in a secure database and used for improved problem determination.

For more information about accessing the IMM2, see Chapter 4 “Accessing the IMM2” on page 43.



---

## Chapter 7. Installing, removing, and replacing compute node components

Use this information to install, remove, and replace FRUs and optional devices in the compute node.

See Chapter 5 “Parts listing, Types 7167 and 2590” on page 51 to determine whether a component is a consumable part, Tier 1 CRU, or Tier 2 CRU.

For information about the terms of the warranty and getting service and assistance, see the *Warranty Information* document.

---

### Installing an optional device

Some compute node components are available as both an optional device and a replaceable component. The installation procedure is the same for the optional device and the replaceable component.

---

### Installation guidelines

Before you remove or replace a FRU or install an optional device, read the following information:

- Before you begin, read “Safety” on page iii and “Handling static-sensitive devices” on page 828. This information will help you work safely.
- When you install your new compute node, take the opportunity to download and apply the most recent firmware updates. This step will help to ensure that any known issues are addressed and that your compute node is ready to function at maximum levels of performance. To download the latest firmware and device drivers, go to <http://www.ibm.com/support/fixcentral> and select **PureSystems, PureFlex System, Compute Node** and **x440 Compute Node**.
- Observe good housekeeping in the area where you are working. Place removed covers and other parts in a safe place.
- Back up all important data before you make changes to hard disk drives.
- Before you remove a compute node from the Flex System chassis, you must shut down the operating system and turn off the compute node. You do not have to shut down the chassis itself.
- Blue on a component indicates touch points, where you can grip the component to remove it from or install it in the compute node, open or close a latch, and so on.
- For a list of supported optional devices for the compute node, see <http://www.lenovo.com/serverproven/>.

### System reliability guidelines

Use these guidelines to ensure that the compute node meets the cooling and system reliability requirements:

- To ensure proper cooling, the Flex System chassis is not operated without a compute node or node bay filler in each node bay. See for additional information.
- A socket cover and heat-sink filler or a microprocessor and heat sink must always be installed on microprocessor sockets 1, 3, and 4. Microprocessor socket 2 will only have a socket cover when a microprocessor is not install. If the compute node has only one microprocessor, it must be installed in microprocessor socket 1.
- The air baffles are installed over the DIMM connectors.
- The ventilation holes on the compute node are not blocked.

## Handling static-sensitive devices

To reduce the possibility of damage from electrostatic discharge, observe these precautions.

**Attention:** Static electricity can damage the compute node and other electronic devices. To avoid damage, keep static-sensitive devices in their static-protective packages until you are ready to install them.

- When you work on a Flex System chassis that has an electrostatic discharge (ESD) connector, use a wrist strap, especially when you handle modules, optional devices, or compute nodes. To work correctly, the wrist strap must have a good contact at both ends (touching your skin at one end and firmly connected to the ESD connector on the front or back of the Flex System chassis).
- Limit your movement. Movement can cause static electricity to build up around you.
- Handle the device carefully, holding it by its edges or its frame.
- Do not touch solder joints, pins, or exposed circuitry.
- Do not leave the device where others can handle and damage it.
- While the device is still in its static-protective package, touch it to an *unpainted* metal part of the Flex System chassis or any *unpainted* metal surface on any other grounded rack component in the rack in which you are installing the device for at least 2 seconds. This drains static electricity from the package and from your body.
- Remove the device from its package and install it directly into the compute node without setting down the device. If it is necessary to set down the device, put it back into its static-protective package. Do not place the device on the compute node cover or on a metal surface.
- Take additional care when you handle devices during cold weather. Heating reduces indoor humidity and increases static electricity.

## Returning a device or component

If you are instructed to return a device or component, follow all packaging instructions, and use any packaging materials for shipping that are supplied to you.

## Updating the compute node configuration

Use this information to update the compute node configuration.

When the compute node starts for the first time after you add or remove an internal device, you might receive a message that the configuration has changed. The Setup utility automatically starts so that you can save the new configuration settings. See “Using the Setup utility” on page 26 for more information about the Setup utility.

Some devices have device drivers that you must install. See the documentation that comes with each device for information about installing device drivers.

The compute node operates as a symmetric multiprocessing (SMP) compute node, regardless of how many microprocessors are installed. For optimum performance, you must upgrade the operating system to support SMP. See Chapter 3 “Installing the operating system” on page 39 and your operating-system documentation for additional information.

---

## Removing a compute node from a chassis

Use this information to remove a compute node from a Flex System chassis.

Before you remove a compute node, complete the following steps:

1. Read “Safety” on page iii and “Installation guidelines” on page 827.



2. If the compute node is operating, shut down the operating system.
3. Press the power button to turn off the compute node (see “Turning off the compute node” on page 17 for more information).

To remove the compute node from a chassis, complete the following steps:

- Step 1. Open the front handles as shown in the illustration. The compute node moves out of the node bay approximately 0.6 cm (0.25 inch).

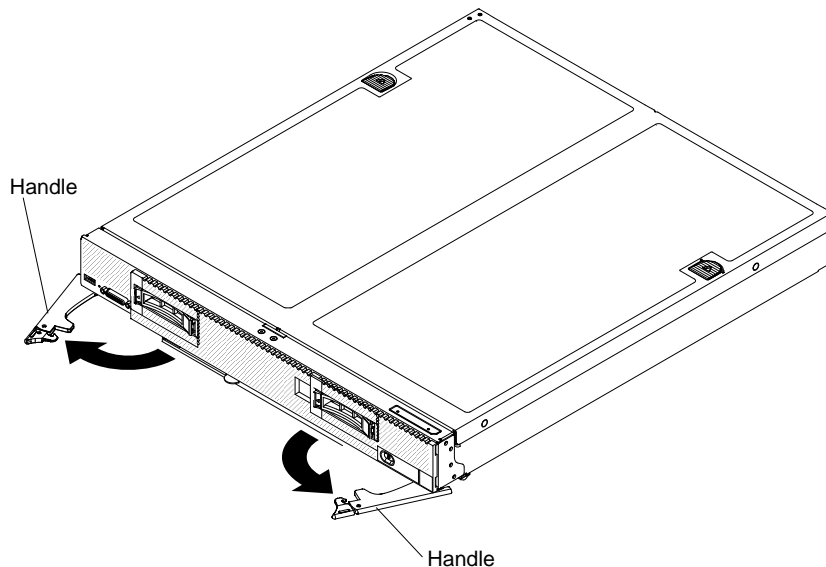

**Attention:**

- To maintain proper system cooling, do not operate the Flex System chassis without a compute node or node bay filler installed in each node bay.
- When you remove the compute node, note the node bay number. Reinstalling a compute node into a different node bay from the one it was removed from can have unintended consequences. Some configuration information and update options are established according to node bay number. If you reinstall the compute node into a different node bay, you might have to reconfigure the compute node.

- Step 2. Pull the compute node out of the node bay.

- Step 3. Install either a node bay filler or another compute node in the node bay within 1 minute.

If you are instructed to return the compute node, follow all packaging instructions, and use any packaging materials for shipping that are supplied to you.

---

## Installing a compute node in a chassis

Use this information to install a compute node in a Flex System chassis.

- Before you install a x440 Compute Node Types 7167 and 2590 in a chassis that is managed by Flex System Manager management software, make sure that the management software is version 1.1.1.0 or later. To determine whether your management software must be updated, and for more information about downloading and installing an update, see the "Updating systems" section of the .
- Before you install a x440 Compute Node Types 7167 and 2590 in a chassis, make sure the Chassis Management Module firmware release date is 08/20/2012 or later. To determine whether your CMM firmware must be updated, log on to the Chassis Management Module web interface. Click on the

**Chassis Management Module** in the graphical user interface; then, select **Firmware** . To update the CMM firmware to the latest release, see <http://www.ibm.com/support/fixcentral>. Select **PureSystems, PureFlex System, Chassis, Enterprise Chassis, Your operating system** and **Continue**.

- If you are installing a compute node model that does not have an integrated Ethernet controller, you must install a network interface adapter before you install the compute node in the chassis for management network communication. For a list of supported optional devices for the compute node, see <http://www.lenovo.com/serverproven/>.

Before you install the compute node in a chassis, read “Safety” on page iii and “Installation guidelines” on page 827.

#### Statement 21



#### CAUTION:

**Hazardous energy is present when the compute node is connected to the power source. Always replace the compute node cover before installing the compute node.**

To install the compute node in a chassis, complete the following steps.

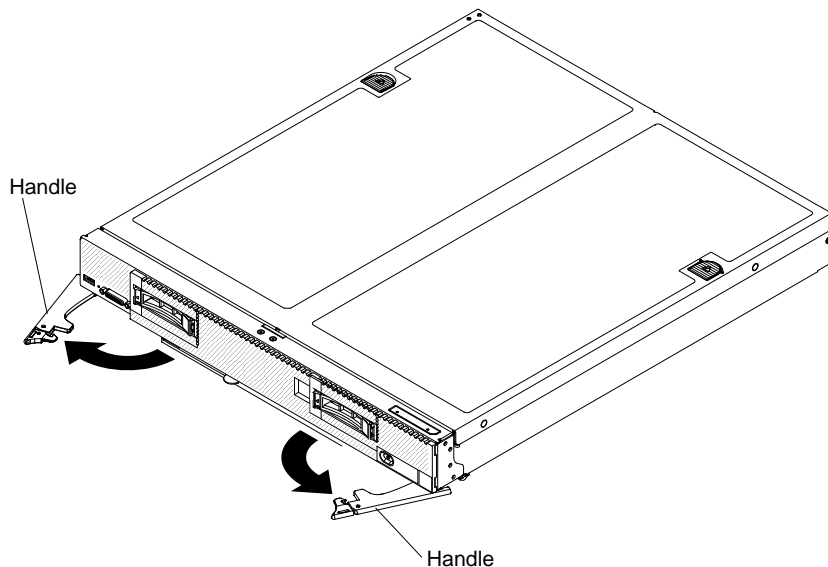

Step 1. Select the node bay.

#### Notes:

1. If you are reinstalling a compute node that you removed, you must install it in the same node bay from which you removed it. Some compute node configuration information and update options are established according to node bay number. Reinstalling a compute node into a different node bay can have unintended consequences. If you reinstall the compute node into a different node bay, you might have to reconfigure the compute node.
2. To maintain proper system cooling, do not operate the Flex System chassis without a compute node or node bay filler in each node bay.

Step 2. Make sure that the front handles on the compute node are in the open position.

Step 3. Slide the compute node into the node bay until it stops.

Step 4. Push the front handles on the front of the compute node to the closed position.

**Note:** After the compute node is installed, the IMM2 in the compute node initializes and synchronizes with the Chassis Management Module. This process takes approximately 90 seconds to complete. The power LED flashes rapidly, and the power button on the compute node does not respond until this process is complete.

Step 5. Turn on the compute node (see “Turning on the compute node” on page 16 for instructions).

Step 6. Make sure that the power LED on the compute node control panel is lit continuously, indicating that the compute node is receiving power and is turned on.

Step 7. If you have other compute nodes to install, do so now.

Step 8. You can place identifying information on the label tabs that are accessible from the front of the compute node.

If this is the initial installation of the compute node in the chassis, you must configure the compute node through the Setup utility and install the compute node operating system. See for details.

If you have changed the configuration of the compute node or if you are installing a different compute node from the one that you removed, you must configure the compute node through the Setup utility, and you might have to install the compute node operating system (see “Using the Setup utility” on page 26).

---

## Removing and replacing Tier 1 customer replaceable units (CRUs)

Use this information for removing and replacing Tier 1 CRUs.

Replacement of Tier 1 CRUs is your responsibility. If Lenovo installs a Tier 1 CRU at your request, you will be charged for the installation.

## Removing the adapter-retention assembly

Use this information to remove the adapter-retention assembly.

Before you remove the adapter-retention assembly, complete the following steps:

1. Read “Safety” on page iii and “Installation guidelines” on page 827.
2. If the compute node is installed in a Flex System chassis, remove it (see “Removing a compute node from a chassis” on page 828 for instructions).
3. Carefully lay the compute node on a flat, static-protective surface, orienting the compute node with the bezel pointing toward you.

The adapter-retention assembly consists of five separate parts. You can replace only the parts that you choose and save the unused parts for future use.

To remove the adapter-retention assembly, complete the following steps.

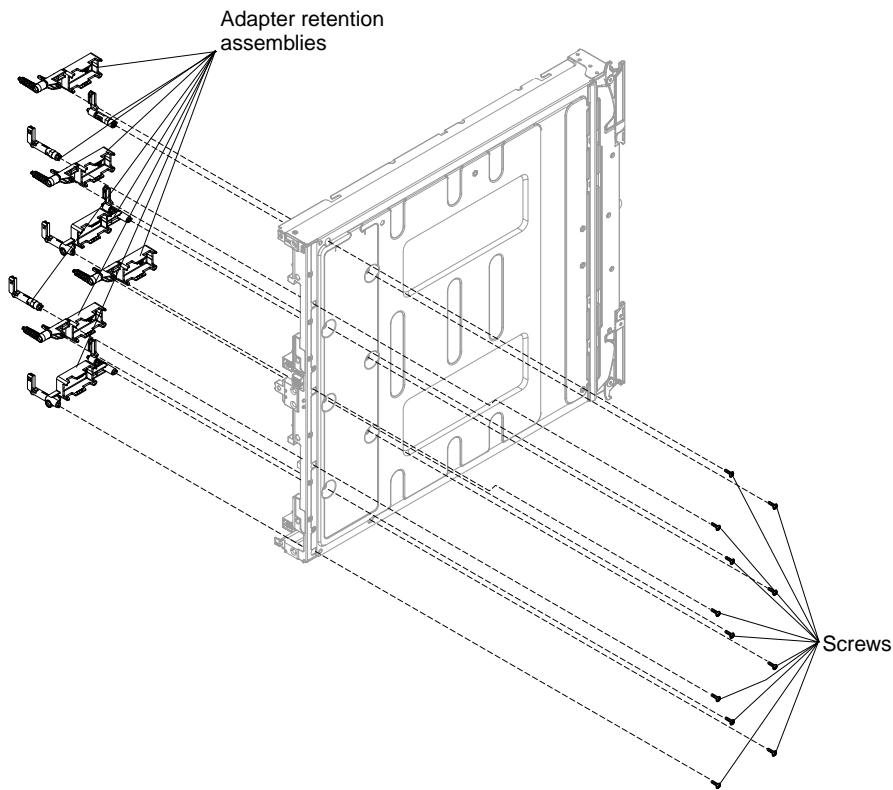

- Step 1. Remove the cover (see “Removing the compute node cover” on page 836).
- Step 2. Remove the air baffles.
- Step 3. If necessary, remove the I/O expansion adapters (see “Removing an I/O expansion adapter” on page 857).
- Step 4. Carefully place the chassis on its side with the front handle side up.
- Step 5. Using a T9 Torx screwdriver, remove the three screws that secure the adapter-retention assembly.
- Step 6. Lift the adapter-retention assembly from the system board.
- Step 7. Carefully return the chassis to the bottom-side-down orientation.

If you are instructed to return the adapter-retention assembly, follow all packaging instructions, and use any packaging materials for shipping that are supplied to you.

## Installing the adapter-retention assembly

Use this information to install the adapter-retention assembly.

Before you install the adapter-retention assembly, complete the following steps:

1. Read “Safety” on page iii and “Installation guidelines” on page 827.
2. If the compute node is installed in a Flex System chassis, remove it (see “Removing a compute node from a chassis” on page 828 for instructions).
3. Carefully lay the compute node on a flat, static-protective surface, orienting the compute node with the bezel pointing toward you.

The adapter-retention assembly consists of five separate parts. You can replace only the parts that you choose and save the unused parts for future use.

To install the adapter-retention assembly, complete the following steps.

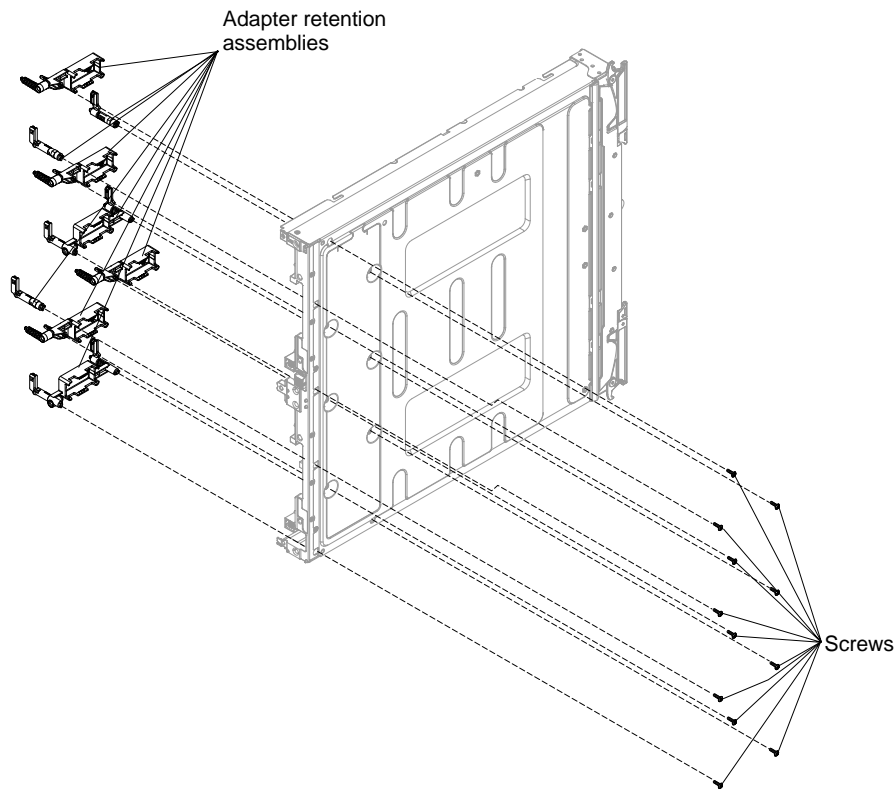

- Step 1. Remove the cover (see “Removing the compute node cover” on page 836).
- Step 2. Remove the air baffles.
- Step 3. Carefully place the chassis on its side with the front handle side up.
- Step 4. Align the adapter-retention assembly on the system board.
- Step 5. Using a T9 Torx screwdriver, install the screws that secure the adapter-retention assembly.
- Step 6. Carefully return the chassis to the bottom-side-down orientation.
- Step 7. Install the I/O expansion adapters, if you removed them (see “Installing an I/O expansion adapter” on page 858).
- Step 8. Install the air baffles.

**Attention:** Install the air baffles with the arrow indicating airflow direction pointing to the rear of the compute node.

After you install the adapter-retention assembly, complete the following steps:

1. Install the cover onto the compute node (see “Installing the compute node cover” on page 838 for instructions).
2. Install the compute node into the chassis (see “Installing a compute node in a chassis” on page 829 for instructions).

## Removing the bezel

Use this information to remove the bezel.

Before you remove the bezel, read “Safety” on page iii and “Installation guidelines” on page 827.

To remove the bezel, complete the following steps.

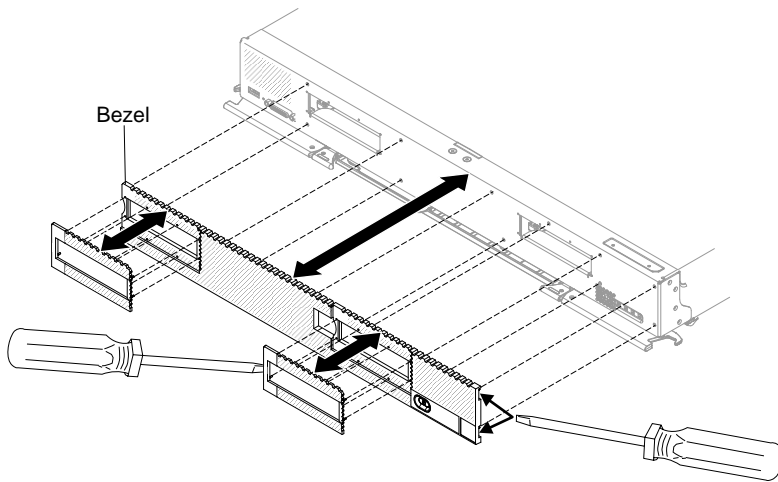

Step 1. Use a flat-blade screwdriver to carefully pull the bezel from the compute node.

Step 2. Lift the bezel from the compute node.

If you are instructed to return the bezel, follow all packaging instructions, and use any packaging materials for shipping that are supplied to you.

## Installing the bezel

Use this information to install the bezel.

Before you install the bezel, read “Safety” on page iii and “Installation guidelines” on page 827.

To install the bezel, complete the following steps.

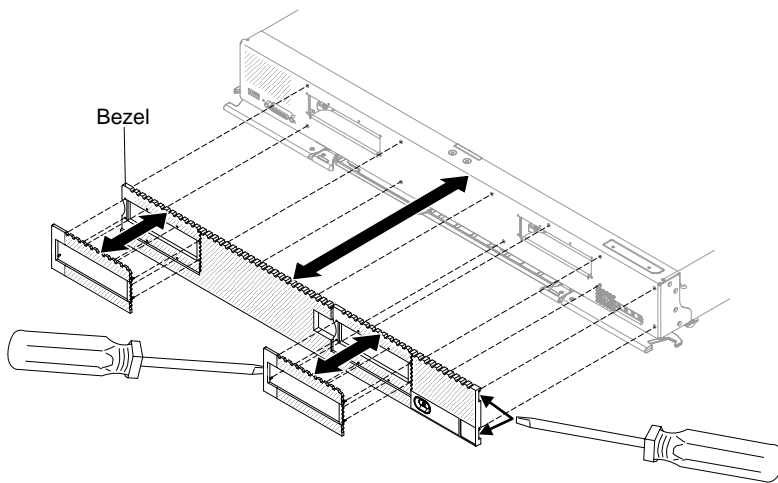

Step 1. Position the bezel on the front of the compute node.

Step 2. Press the bezel securely against the chassis.

**Note:** Make sure that the bezel is pressed flat against the chassis around the power button, to maintain access to the power button.

## Removing the CMOS battery

Use this information to remove the CMOS battery.

Before you remove the CMOS battery, complete the following steps:

1. Read “Safety” on page iii and “Installation guidelines” on page 827.
2. If the compute node is installed in a Flex System chassis, remove it (see “Removing a compute node from a chassis” on page 828 for instructions).
3. Carefully lay the compute node on a flat, static-protective surface, orienting the compute node with the bezel pointing toward you.

To remove the CMOS battery, complete the following steps:

- Step 1. Remove the cover (see “Removing the compute node cover” on page 836).
- Step 2. Locate the CMOS battery on the system board (see “System-board connectors” on page 18).
- Step 3. If a cover is over the CMOS battery, remove the cover.
- Step 4. Pivot the CMOS battery toward the middle of the compute node.

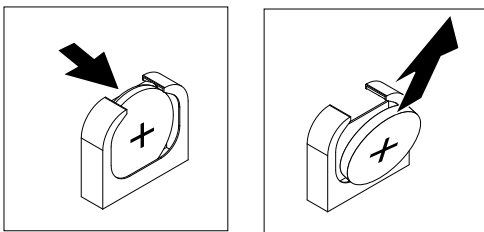

- Step 5. Lift the CMOS battery from the socket.

After you remove the CMOS battery, dispose of the CMOS battery as required by local ordinances or regulations.

## Installing the CMOS battery

Use this information to install a CMOS battery.

Before you install the CMOS battery, complete the following steps:

1. Read “Safety” on page iii and “Installation guidelines” on page 827.
2. If the compute node is installed in a Flex System chassis, remove it (see “Removing a compute node from a chassis” on page 828 for instructions).
3. Carefully lay the compute node on a flat, static-protective surface, orienting the compute node with the bezel pointing toward you.

The following notes describe information that you must consider when you are replacing the CMOS battery in the compute node:

- You must replace the CMOS battery with a lithium CMOS battery of the same type.
- To order replacement batteries, call 1-800-426-7378 within the United States, and 1-800-465-7999 or 1-800-465-6666 within Canada. Outside the U.S. and Canada, call your marketing representative or authorized reseller.
- After you replace the CMOS battery, you must reconfigure the compute node and reset the system date and time.
- To avoid possible danger, read and follow the following safety statement.

### Statement 2

**CAUTION:**

When replacing the lithium battery, use only Part Number 33F8354 or an equivalent type battery recommended by the manufacturer. If your system has a module containing a lithium battery, replace it only with the same module type made by the same manufacturer. The battery contains lithium and can explode if not properly used, handled, or disposed of. *Do not:*

- Throw or immerse into water
- Heat to more than 100° C (212° F)
- Repair or disassemble

Dispose of the battery as required by local ordinances or regulations.

**Attention:** Touching the CMOS battery on a metal surface, such as the side of the compute node, when you replace the CMOS battery can cause it to fail.

To install a CMOS battery, complete the following steps:

- Step 1. Remove the cover (see “Removing the compute node cover” on page 836).
- Step 2. Follow any special handling and installation instructions that come with the CMOS battery.
- Step 3. Locate the CMOS battery socket on the system board (see “System-board connectors” on page 18).
- Step 4. Orient the CMOS battery so that the positive (+) side faces in toward the center of the compute node.



- Step 5. Pivot the CMOS battery so that you can insert it into the bottom of the socket.
- Step 6. As you slide the CMOS battery into place, press the top of the CMOS battery into the socket.
- Step 7. If you removed a cover from the battery, replace the cover.

After you install the CMOS battery, complete the following steps:

1. Install the cover onto the compute node (see “Installing the compute node cover” on page 838 for instructions).
2. Install the compute node into the chassis (see “Installing a compute node in a chassis” on page 829 for instructions).
3. Turn on the compute node, start the Setup utility, and reset the configuration (see “Using the Setup utility” on page 26 for instructions).

## Removing the compute node cover

Use this information to remove the cover from a compute node.

Before you remove the compute node cover, complete the following steps:

1. Read “Safety” on page iii and “Installation guidelines” on page 827.
2. If the compute node is installed in a Flex System chassis, remove it (see “Removing a compute node from a chassis” on page 828 for instructions).



- Carefully lay the compute node on a flat, static-protective surface, orienting the compute node with the bezel pointing toward you.

**Statement 12**



**CAUTION:**  
The following label indicates a hot surface nearby.



**Statement 21**



**CAUTION:**  
Hazardous energy is present when the compute node is connected to the power source. Always replace the compute node cover before installing the compute node.

To remove the compute node cover, complete the following steps:

- Step 1. Press on the release button and the push point at the same time and slide the cover toward the rear of the compute node.
- Step 2. Lift the cover away from the compute node.

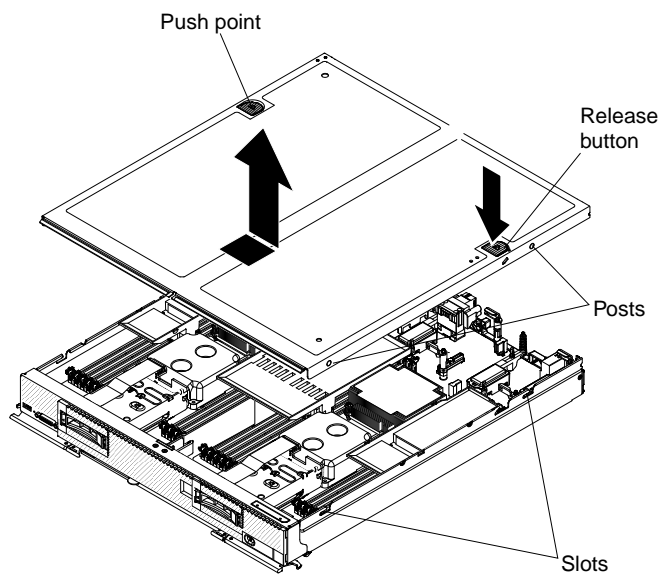

- Step 3. Lay the cover flat or store it for future use.

If you are instructed to return the cover, follow all packaging instructions, and use any packaging materials for shipping that are supplied to you.

## Installing the compute node cover

Use this information to install the compute node cover.

Before you install the compute node cover, read “Safety” on page iii and “Installation guidelines” on page 827.

**Attention:** You cannot insert the compute node into the Flex System chassis until the cover is installed and closed. Do not attempt to override this protection.

### Statement 21



#### CAUTION:

**Hazardous energy is present when the compute node is connected to the power source. Always replace the compute node cover before installing the compute node.**

To install the compute node cover, complete the following steps:

- Step 1. Carefully lay the compute node on a flat, static-protective surface, orienting the compute node with the bezel pointing toward you.
- Step 2. Orient the cover so that the posts on the inside of the cover slide into the slots on the compute node.

**Note:** Before you close the cover, make sure that the air baffles and all components are installed and seated correctly and that you have not left loose tools or parts inside the compute node.

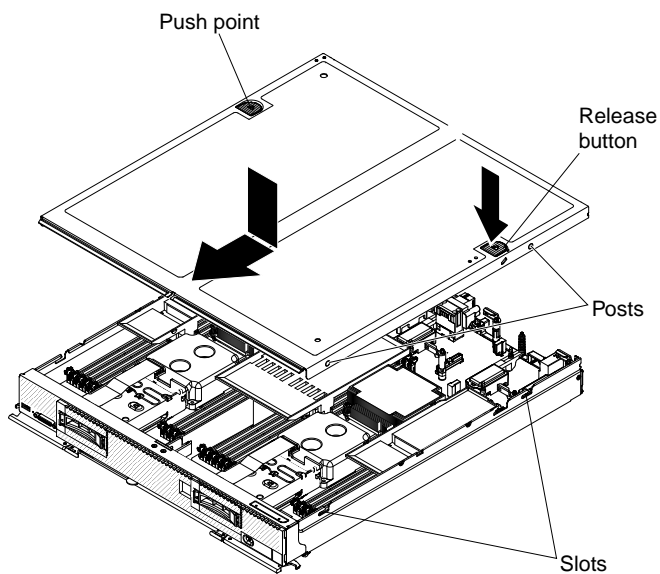

- Step 3. Hold the front of the compute node and slide the cover forward to the closed position, until it clicks into place.

After you install the compute node cover, install the compute node into the chassis (see “Installing a compute node in a chassis” on page 829 for instructions).

## Removing a DIMM

Use this information to remove a dual inline memory module (DIMM).

Before you remove a DIMM, complete the following steps:

1. Read “Safety” on page iii and “Installation guidelines” on page 827.
2. If the compute node is installed in a Flex System chassis, remove it (see “Removing a compute node from a chassis” on page 828 for instructions).
3. Carefully lay the compute node on a flat, static-protective surface, orienting the compute node with the bezel pointing toward you.

After you install or remove a DIMM, you must change and save the new configuration information by using the Setup utility. When you turn on the compute node, a message indicates that the memory configuration has changed. Start the Setup utility and select **Save Settings** (see “Using the Setup utility” on page 26 for more information) to save changes.

To remove a DIMM, complete the following steps.

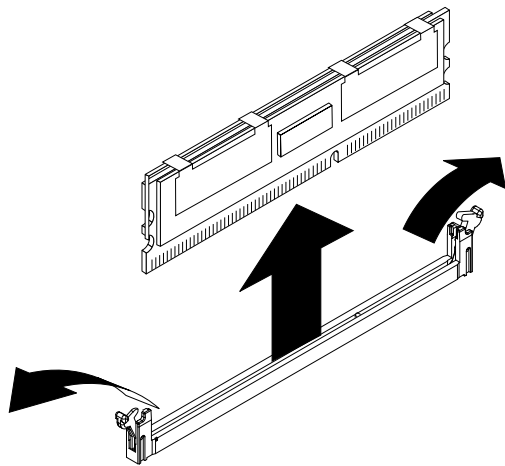

- Step 1. Remove the cover (see “Removing the compute node cover” on page 836).
- Step 2. Remove the air baffle that is installed over the DIMM connector.

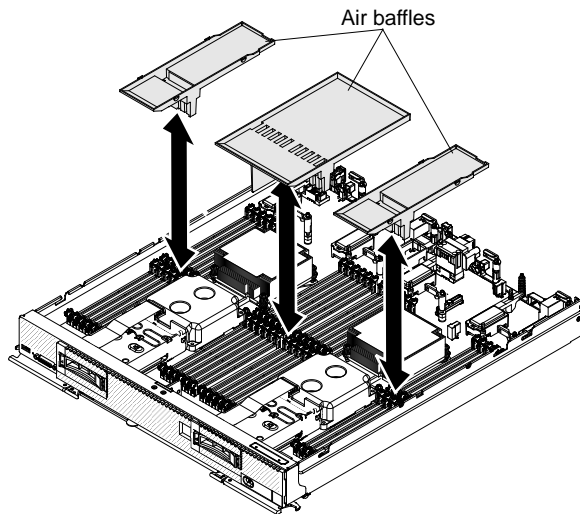

Step 3. Locate the DIMM connectors (see “System-board connectors” on page 18). Determine which DIMM you want to remove from the compute node.

**Note:** You might have to remove the I/O expansion adapter.

**Attention:** To avoid breaking the retaining clips or damaging the DIMM connectors, handle the clips gently.

Step 4. Make sure that both retaining clips on the DIMM connector from which you are removing the DIMM are in the open position.

**Note:** You might have to remove the I/O expansion adapter.

Step 5. Pull the DIMM out of the connector.

Step 6. If you are not immediately replacing the DIMM, install the air baffle.

**Attention:**

- Install the air baffles with the arrow indicating air flow direction pointing to the rear of the compute node.
- To maintain proper system cooling, do not operate the compute node without air baffles installed over the DIMM connectors.

If you are instructed to return the DIMM, follow all packaging instructions, and use any packaging materials for shipping that are supplied to you.

## Installing a DIMM

Use this information to install a DIMM.

Before you install a DIMM, complete the following steps:

1. Read “Safety” on page iii and “Installation guidelines” on page 827.
2. Read the documentation that comes with the DIMMs.
3. If the compute node is installed in a Flex System chassis, remove it (see “Removing a compute node from a chassis” on page 828 for instructions).
4. Carefully lay the compute node on a flat, static-protective surface, orienting the compute node with the bezel pointing toward you.

This component can be installed as an optional device or as a CRU. The installation procedure is the same for the optional device and the CRU.

After you install or remove a DIMM, you must change and save the new configuration information by using the Setup utility. When you turn on the compute node, a message indicates that the memory configuration has changed. Start the Setup utility and select **Save Settings** (see “Using the Setup utility” on page 26 for more information) to save changes.

If you are installing a DIMM as a result of a DIMM failure, you might have to reenable the DIMM. To re-enable the DIMM, complete the following steps:

1. Verify that the amount of installed memory is the expected amount of memory through the operating system, by watching the monitor as the compute node starts, by using the CMM `sol` command, or through the management node (if available).
  - For more information about the CMM `sol` command, see the .
  - For more information about Lenovo XClarity Administrator, see <https://support.lenovo.com/us/en/documents/LNVO-XCLARIT>.
  - For more information about Flex System Manager management software, see .
2. Run the Setup utility to reenable the DIMMs (see “Using the Setup utility” on page 26 for more information).

The compute node has a total of 48 dual inline memory module (DIMM) connectors. The compute node supports low-profile (LP) DDR3 DIMMs with error-correcting code (ECC) in 4 GB, 8 GB, 16 GB and 32 GB capacities.

The following illustration shows the system-board components, including the DIMM connectors.

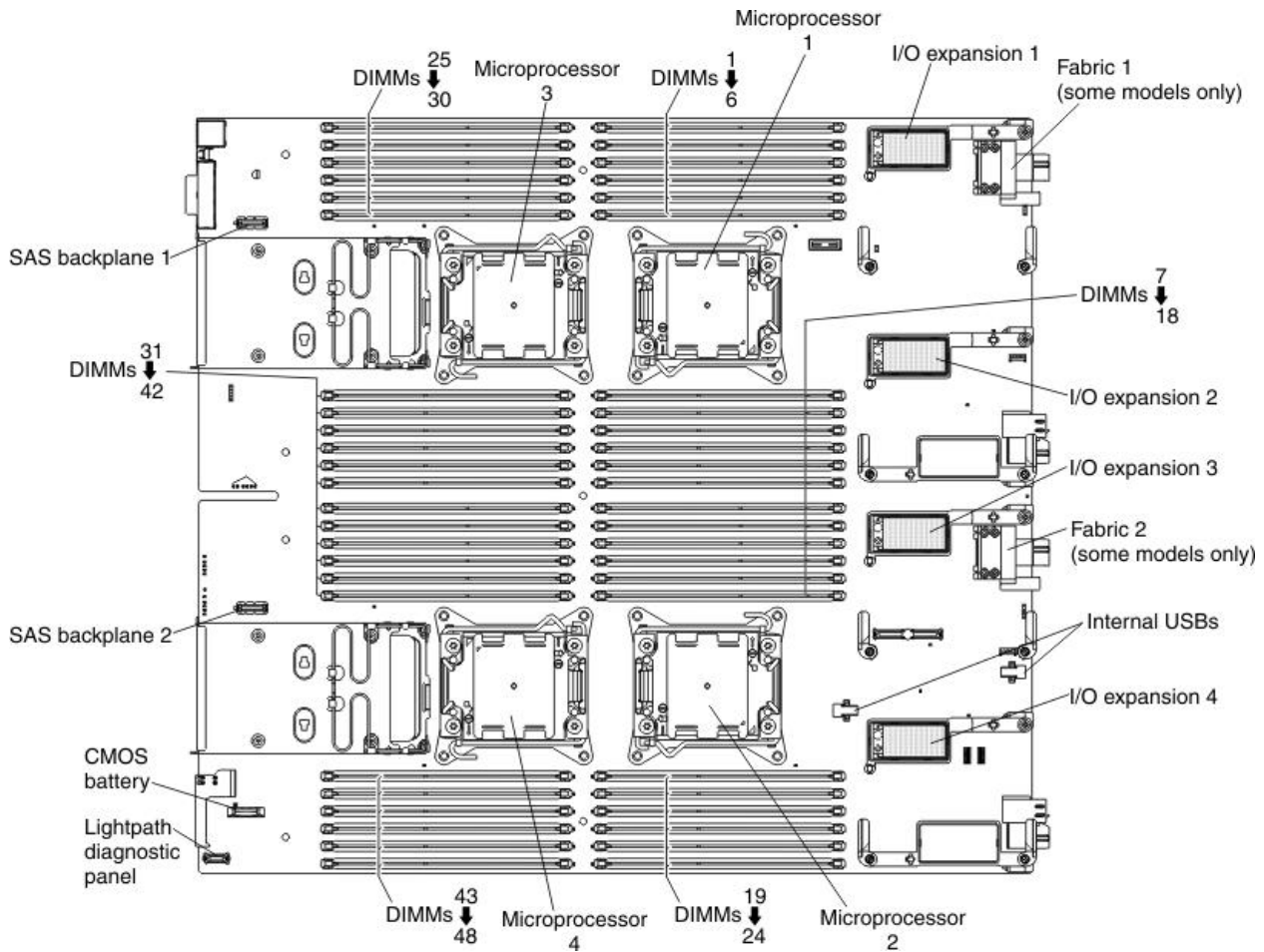

The memory is accessed internally through 16 channels (four channels for each microprocessor). Each channel contains three DIMM connectors. Each channel can have a maximum of eight ranks. The following table lists each channel and shows which DIMM connectors are in the channel.

Table 12. Memory-channel configuration

| Microprocessor   | Memory channel | DIMM connectors |
|------------------|----------------|-----------------|
| Microprocessor 1 | Channel 1      | 1, 2, and 3     |
|                  | Channel 0      | 4, 5, and 6     |
|                  | Channel 2      | 7, 8, and 9     |
|                  | Channel 3      | 10, 11, and 12  |
| Microprocessor 2 | Channel 1      | 13, 14, and 15  |
|                  | Channel 0      | 16, 17, and 18  |
|                  | Channel 2      | 19, 20, and 21  |
|                  | Channel 3      | 22, 23, and 14  |
| Microprocessor 3 | Channel 2      | 25, 26, and 27  |
|                  | Channel 3      | 28, 29, and 30  |
|                  | Channel 1      | 31, 32, and 33  |

Table 12. Memory-channel configuration (continued)

| Microprocessor   | Memory channel | DIMM connectors |
|------------------|----------------|-----------------|
|                  | Channel 0      | 34, 35, and 36  |
| Microprocessor 4 | Channel 2      | 37, 38, and 39  |
|                  | Channel 3      | 40, 41, and 42  |
|                  | Channel 1      | 43, 44, and 45  |
|                  | Channel 0      | 46, 47, and 48  |

The following notes describe information that you must consider when you install memory:

- You cannot mix RDIMMs, LRDIMMs and UDIMMs in the same compute node.
- UDIMMs are not supported at three DIMMs per channel.
- A total of eight ranks on each channel is supported.
- If a quad-rank DIMM is installed, install it in the connector at the end of the memory channel.
- If a channel has one or more quad-rank RDIMMs, only two DIMMs per channel is supported. The quad-rank, eight rank per channel limitation only applies to RDIMMs. Quad-rank LRDIMMs can be installed at three DIMMs per channel since the processor recognizes LRDIMMs as dual-rank DIMMs.

There are three memory modes:

- **Independent-channel mode:** Independent-channel mode provides a maximum of 384 GB of usable memory per processor and 1536 GB of usable memory with all four processors installed using 32 GB DIMMs. DIMMs must be first installed in the last physical DIMM connector of each channel. DIMMs should also be installed one DIMM per channel first. The best performance is seen with an even memory distribution among all four channels on the microprocessor. DIMMs can be installed without matching sizes. Individual channels may run at different DIMM timings, but all channels must run at the same interface frequency. DIMMs with different timing parameters can be installed in different connectors of the same channel, but only timings that support the slowest DIMM are applied to all the DIMMs. Faster DIMMs operate at timings that are supported by the slowest installed DIMM.
- **Mirrored-channel mode:** In mirrored-channel mode, memory is installed in pairs. Both DIMMs in a pair must be identical in capacity, type, and rank count. The channels are grouped in pairs with each channel receiving the same data. One channel is used as a backup of the other, which provides redundancy. In mirrored-channel mode, memory must be installed in pairs. The memory content is mirrored between channel 0 and channel 1 and between channel 2 and channel 3. Mirrored-channel mode requires that channel 0 and channel 1, and channel 2 and channel 3 are be populated identically in regard to size and organization. DIMM connector populations within a channel do not have to be identical, but the same DIMM connector location across channel 0 and channel 1 and across channel 2 and channel 3 must be populated in the same way. The effective memory that is available to the system is only half of what is installed.
- **Rank-sparing mode:** In rank-sparing mode, one memory DIMM rank serves as a spare of the other ranks on the same channel. The spare rank is held in reserve and is not used as active memory. The spare rank must have identical or larger memory capacity than all the other active DIMM ranks on the same channel. After an error threshold is surpassed, the contents of that rank are copied to the spare rank. The failed rank of DIMMs is taken offline, and the spare rank is put online and used as active memory in place of the failed rank. The following notes describe additional information that you must consider when you select rank-sparing memory mode:
  - Memory sparing on one channel is independent of the sparing on all other channels.
  - You can use the Setup utility to determine the status of the DIMM ranks.

- If only one DIMM is present in a channel and the DIMM is dual or single rank, then sparing mode should not be enabled.

Rank-sparing on one channel is independent of the sparing on all other channels. You can use the Setup utility to determine the status of the DIMM ranks.

Install DIMMs in the order that is indicated in the following table for independent-channel mode.

Table 13. DIMM population sequence for independent-channel mode

| Number of DIMMs installed | 1 microprocessor installed                      | 2 microprocessors installed   | 4 microprocessors installed  |
|---------------------------|---|---|--|
| 1                         | DIMM 4  | DIMM 4  | DIMM 4   |
| 2                         | DIMMs 1 and 4                                   | DIMMs 4 and 16  | DIMMs 4 and 16   |
| 3                         | DIMMs 1, 4, and 9                               | DIMMs 1, 4, and 16  | DIMMs 4, 16, and 33  |
| 4                         | DIMMs 1, 4, 9, and 12                           | DIMMs 1, 4, 13, and 16  | DIMMs 4, 16, 33, and 45  |
| 5                         | DIMMs 1, 4, 9, 5, and 12                        | DIMMs 1, 4, 9, 13, and 16   | DIMMs 1, 4, 16, 33, and 45   |
| 6                         | DIMMs 1, 2, 4, 9, 5, and 12                     | DIMMs 1, 4, 9, 13, 16, and 21   | DIMMs 1, 4, 13, 16, 33, and 45   |
| 7                         | DIMMs 1, 2, 4, 8, 9, 5, and 12                  | DIMMs 1, 4, 9, 12, 13, 16, and 21   | DIMMs 1, 4, 13, 16, 33, 36, and 45   |
| 8                         | DIMMs 1, 2, 4, 8, 9, 5, 11, and 12              | DIMMs 1, 4, 9, 12, 13, 16, 21, and 24                                     | DIMMs 1, 4, 13, 16, 33, 36, 45, and 48                                       |
| 9                         | DIMMs 1, 2, 4, 6, 8, 9, 5, 11, and 12           | DIMMs 1, 4, 5, 9, 12, 13, 16, 21, and 24                                  | DIMMs 1, 4, 9, 13, 16, 33, 36, 45, and 48                                    |
| 10                        | DIMMs 1, 2, 3, 4, 6, 8, 9, 5, 11, and 12        | DIMMs 1, 4, 5, 9, 12, 13, 16, 17, 21, and 24                              | DIMMs 1, 4, 9, 13, 16, 21, 33, 36, 45, and 48                                |
| 11                        | DIMMs 1, 2, 3, 4, 6, 7, 8, 9, 5, 11, and 12     | DIMMs 1, 2, 4, 5, 9, 12, 13, 16, 17, 21, and 24                           | DIMMs 1, 4, 9, 13, 16, 21, 28, 33, 36, 45, and 48                            |
| 12                        | DIMMs 1, 2, 3, 4, 6, 7, 8, 9, 10, 5, 11, and 12 | DIMMs 1, 2, 4, 5, 9, 12, 13, 14, 16, 17, 21, and 24                       | DIMMs 1, 4, 9, 13, 16, 21, 28, 33, 36, 40, 45, and 48                        |
| 13                        |   | DIMMs 1, 2, 4, 5, 8, 9, 12, 13, 14, 16, 17, 21, and 24                    | DIMMs 1, 4, 9, 12, 13, 16, 21, 28, 33, 36, 40, 45, and 48                    |
| 14                        |   | DIMMs 1, 2, 4, 5, 8, 9, 12, 13, 14, 16, 17, 20, 21, and 24                | DIMMs 1, 4, 9, 12, 13, 16, 21, 24, 28, 33, 36, 40, 45, and 48                |
| 15                        |   | DIMMs 1, 2, 4, 5, 8, 9, 11, 12, 13, 14, 16, 17, 20, 21, and 24            | DIMMs 1, 4, 9, 12, 13, 16, 21, 24, 25, 28, 33, 36, 40, 45, and 48            |
| 16                        |   | DIMMs 1, 2, 4, 5, 8, 9, 11, 12, 13, 14, 16, 17, 20, 21, 23, and 24        | DIMMs 1, 4, 9, 12, 13, 16, 21, 24, 25, 28, 33, 36, 37, 40, 45, and 48        |
| 17                        |   | DIMMs 1, 2, 4, 5, 6, 8, 9, 11, 12, 13, 14, 16, 17, 20, 21, 23, and 24     | DIMMs 1, 4, 5, 9, 12, 13, 16, 21, 24, 25, 28, 33, 36, 37, 40, 45, and 48     |
| 18                        |   | DIMMs 1, 2, 4, 5, 6, 8, 9, 11, 12, 13, 14, 16, 17, 18, 20, 21, 23, and 24 | DIMMs 1, 4, 5, 9, 12, 13, 16, 17, 21, 24, 25, 28, 33, 36, 37, 40, 45, and 48 |



Table 13. DIMM population sequence for independent-channel mode (continued)

| Number of DIMMs installed | 1 microprocessor installed | 2 microprocessors installed   | 4 microprocessors installed  |
|---------------------------|----------------------------|---|--|
| 19                        |                            | DIMMs 1, 2, 3, 4, 5, 6, 8, 9, 11, 12, 13, 14, 16, 17, 18, 20, 21, 23, and 24                    | DIMMs 1, 4, 5, 9, 12, 13, 16, 17, 21, 24, 25, 28, 32, 33, 36, 37, 40, 45, and 48   |
| 20                        |                            | DIMMs 1, 2, 3, 4, 5, 6, 8, 9, 11, 12, 13, 15, 14, 16, 17, 18, 20, 21, 23, and 24                | DIMMs 1, 4, 5, 9, 12, 13, 16, 17, 21, 24, 25, 28, 32, 33, 36, 37, 40, 44, 45, and 48                                       |
| 21                        |                            | DIMMs 1, 2, 3, 4, 5, 6, 7, 8, 9, 11, 12, 13, 15, 14, 16, 17, 18, 20, 21, 23, and 24             | DIMMs 1, 2, 4, 5, 9, 12, 13, 16, 17, 21, 24, 25, 28, 32, 33, 36, 37, 40, 44, 45, and 48                                    |
| 22                        |                            | DIMMs 1, 2, 3, 4, 5, 6, 7, 8, 9, 11, 12, 13, 15, 14, 16, 17, 18, 19, 20, 21, 23, and 24         | DIMMs 1, 2, 4, 5, 9, 12, 13, 14, 16, 17, 21, 24, 25, 28, 32, 33, 36, 37, 40, 44, 45, and 48                                |
| 23                        |                            | DIMMs 1, 2, 3, 4, 5, 6, 7, 8, 9, 10, 11, 12, 13, 15, 14, 16, 17, 18, 19, 20, 21, 23, and 24     | DIMMs 1, 2, 4, 5, 9, 12, 13, 14, 16, 17, 21, 24, 25, 28, 32, 33, 35, 36, 37, 40, 44, 45, and 48                            |
| 24                        |                            | DIMMs 1, 2, 3, 4, 5, 6, 7, 8, 9, 10, 11, 12, 13, 15, 14, 16, 17, 18, 19, 20, 21, 22, 23, and 24 | DIMMs 1, 2, 4, 5, 9, 12, 13, 14, 16, 17, 21, 24, 25, 28, 32, 33, 35, 36, 37, 40, 44, 45, 47, and 48                        |
| 25                        |                            |   | DIMMs 1, 2, 4, 5, 8, 9, 12, 13, 14, 16, 17, 21, 24, 25, 28, 32, 33, 35, 36, 37, 40, 44, 45, 47, and 48                     |
| 26                        |                            |   | DIMMs 1, 2, 4, 5, 8, 9, 12, 13, 14, 16, 17, 20, 21, 24, 25, 28, 32, 33, 35, 36, 37, 40, 44, 45, 47, and 48                 |
| 27                        |                            |   | DIMMs 1, 2, 4, 5, 8, 9, 12, 13, 14, 16, 17, 20, 21, 24, 25, 28, 29, 32, 33, 35, 36, 37, 40, 44, 45, 47, and 48             |
| 28                        |                            |   | DIMMs 1, 2, 4, 5, 8, 9, 12, 13, 14, 16, 17, 20, 21, 24, 25, 28, 29, 32, 33, 35, 36, 37, 40, 41, 44, 45, 47, and 48         |
| 29                        |                            |   | DIMMs 1, 2, 4, 5, 8, 9, 11, 12, 13, 14, 16, 17, 20, 21, 24, 25, 28, 29, 32, 33, 35, 36, 37, 40, 41, 44, 45, 47, and 48     |
| 30                        |                            |   | DIMMs 1, 2, 4, 5, 8, 9, 11, 12, 13, 14, 16, 17, 20, 21, 23, 24, 25, 28, 29, 32, 33, 35, 36, 37, 40, 41, 44, 45, 47, and 48 |

Table 13. DIMM population sequence for independent-channel mode (continued)

| Number of DIMMs installed | 1 microprocessor installed | 2 microprocessors installed | 4 microprocessors installed  |
|---------------------------|----------------------------|-----------------------------|--|
| 31                        |                            |                             | DIMMs 1, 2, 4, 5, 8, 9, 11, 12, 13, 14, 16, 17, 20, 21, 23, 24, 25, 26, 28, 29, 32, 33, 35, 36, 37, 40, 41, 44, 45, 47, and 48                               |
| 32                        |                            |                             | DIMMs 1, 2, 4, 5, 8, 9, 11, 12, 13, 14, 16, 17, 20, 21, 23, 24, 25, 26, 28, 29, 32, 33, 35, 36, 37, 38, 40, 41, 44, 45, 47, and 48                           |
| 33                        |                            |                             | DIMMs 1, 2, 4, 5, 6, 8, 9, 11, 12, 13, 14, 16, 17, 20, 21, 23, 24, 25, 26, 28, 29, 32, 33, 35, 36, 37, 38, 40, 41, 44, 45, 47, and 48                        |
| 34                        |                            |                             | DIMMs 1, 2, 4, 5, 6, 8, 9, 11, 12, 13, 14, 16, 17, 18, 20, 21, 23, 24, 25, 26, 28, 29, 32, 33, 35, 36, 37, 38, 40, 41, 44, 45, 47, and 48                    |
| 35                        |                            |                             | DIMMs 1, 2, 4, 5, 6, 8, 9, 11, 12, 13, 14, 16, 17, 18, 20, 21, 23, 24, 25, 26, 28, 29, 31, 32, 33, 35, 36, 37, 38, 40, 41, 44, 45, 47, and 48                |
| 36                        |                            |                             | DIMMs 1, 2, 4, 5, 6, 8, 9, 11, 12, 13, 14, 16, 17, 18, 20, 21, 23, 24, 25, 26, 28, 29, 31, 32, 33, 35, 36, 37, 38, 40, 41, 43, 44, 45, 47, and 48            |
| 37                        |                            |                             | DIMMs 1, 2, 3, 4, 5, 6, 8, 9, 11, 12, 13, 14, 16, 17, 18, 20, 21, 23, 24, 25, 26, 28, 29, 31, 32, 33, 35, 36, 37, 38, 40, 41, 43, 44, 45, 47, and 48         |
| 38                        |                            |                             | DIMMs 1, 2, 3, 4, 5, 6, 8, 9, 11, 12, 13, 14, 15, 16, 17, 18, 20, 21, 23, 24, 25, 26, 28, 29, 31, 32, 33, 35, 36, 37, 38, 40, 41, 43, 44, 45, 47, and 48     |
| 39                        |                            |                             | DIMMs 1, 2, 3, 4, 5, 6, 8, 9, 11, 12, 13, 14, 15, 16, 17, 18, 20, 21, 23, 24, 25, 26, 28, 29, 31, 32, 33, 34, 35, 36, 37, 38, 40, 41, 43, 44, 45, 47, and 48 |

Table 13. DIMM population sequence for independent-channel mode (continued)

| Number of DIMMs installed | 1 microprocessor installed | 2 microprocessors installed | 4 microprocessors installed   |
|---------------------------|----------------------------|-----------------------------|---|
| 40                        |                            |                             | DIMMs 1, 2, 3, 4, 5, 6, 8, 9, 11, 12, 13, 14, 15, 16, 17, 18, 20, 21, 23, 24, 25, 26, 28, 29, 31, 32, 33, 34, 35, 36, 37, 38, 40, 41, 43, 44, 45, 46, 47, and 48                        |
| 41                        |                            |                             | DIMMs 1, 2, 3, 4, 5, 6, 7, 8, 9, 11, 12, 13, 14, 15, 16, 17, 18, 20, 21, 23, 24, 25, 26, 28, 29, 31, 32, 33, 34, 35, 36, 37, 38, 40, 41, 43, 44, 45, 46, 47, and 48                     |
| 42                        |                            |                             | DIMMs 1, 2, 3, 4, 5, 6, 7, 8, 9, 11, 12, 13, 14, 15, 16, 17, 18, 19, 20, 21, 23, 24, 25, 26, 28, 29, 31, 32, 33, 34, 35, 36, 37, 38, 40, 41, 43, 44, 45, 46, 47, and 48                 |
| 43                        |                            |                             | DIMMs 1, 2, 3, 4, 5, 6, 7, 8, 9, 11, 12, 13, 14, 15, 16, 17, 18, 19, 20, 21, 23, 24, 25, 26, 28, 29, 30, 31, 32, 33, 34, 35, 36, 37, 38, 40, 41, 43, 44, 45, 46, 47, and 48             |
| 44                        |                            |                             | DIMMs 1, 2, 3, 4, 5, 6, 7, 8, 9, 11, 12, 13, 14, 15, 16, 17, 18, 19, 20, 21, 23, 24, 25, 26, 28, 29, 30, 31, 32, 33, 34, 35, 36, 37, 38, 40, 41, 42, 43, 44, 45, 46, 47, and 48         |
| 45                        |                            |                             | DIMMs 1, 2, 3, 4, 5, 6, 7, 8, 9, 10, 11, 12, 13, 14, 15, 16, 17, 18, 19, 20, 21, 23, 24, 25, 26, 28, 29, 30, 31, 32, 33, 34, 35, 36, 37, 38, 40, 41, 42, 43, 44, 45, 46, 47, and 48     |
| 46                        |                            |                             | DIMMs 1, 2, 3, 4, 5, 6, 7, 8, 9, 10, 11, 12, 13, 14, 15, 16, 17, 18, 19, 20, 21, 22, 23, 24, 25, 26, 28, 29, 30, 31, 32, 33, 34, 35, 36, 37, 38, 40, 41, 42, 43, 44, 45, 46, 47, and 48 |

Table 13. DIMM population sequence for independent-channel mode (continued)

| Number of DIMMs installed | 1 microprocessor installed | 2 microprocessors installed | 4 microprocessors installed   |
|---------------------------|----------------------------|-----------------------------|---|
| 47                        |                            |                             | DIMMs 1, 2, 3, 4, 5, 6, 7, 8, 9, 10, 11, 12, 13, 14, 15, 16, 17, 18, 19, 20, 21, 22, 23, 24, 25, 26, 27, 28, 29, 30, 31, 32, 33, 34, 35, 36, 37, 38, 40, 41, 42, 43, 44, 45, 46, 47, and 48     |
| 48                        |                            |                             | DIMMs 1, 2, 3, 4, 5, 6, 7, 8, 9, 10, 11, 12, 13, 14, 15, 16, 17, 18, 19, 20, 21, 22, 23, 24, 25, 26, 27, 28, 29, 30, 31, 32, 33, 34, 35, 36, 37, 38, 39, 40, 41, 42, 43, 44, 45, 46, 47, and 48 |

Install DIMMs in the order that is indicated in the following table for mirrored-channel mode.

Table 14. DIMM population sequence for mirrored-channel mode

| Number of DIMM pairs installed | 1 microprocessor installed   | 2 microprocessor installed   | 4 microprocessor installed  |
|--------------------------------|--|--|---|
| 1                              | DIMMs 1 and 4 <sup>1</sup>   | DIMMs 1 and 4 <sup>1</sup>   | DIMMs 1 and 4 <sup>1</sup>  |
| 2                              | DIMMs 1 and 4, 9 and 12 <sup>1</sup>                                       | DIMMs 1 and 4, 13 and 16 <sup>1</sup>  | DIMMs 1 and 4, 13 and 16 <sup>1</sup>   |
| 3                              | DIMMs 1 and 4, 9 and 12, 2 and 5 <sup>1</sup>                              | DIMMs 1 and 4, 13 and 16, 9 and 12 <sup>1</sup>  | DIMMs 1 and 4, 13 and 16, 33 and 36 <sup>1</sup>  |
| 4                              | DIMMs 1 and 4, 9 and 12, 2 and 5, 8 and 11 <sup>1</sup>                    | DIMMs 1 and 4, 13 and 16, 9 and 12, 21 and 24 <sup>1</sup>   | DIMMs 1 and 4, 13 and 16, 33 and 36, 45 and 48 <sup>1</sup>   |
| 5                              | DIMMs 1 and 4, 9 and 12, 2 and 5, 8 and 11, 3 and 6 <sup>1</sup>           | DIMMs 1 and 4, 13 and 16, 9 and 12, 21 and 24, 2 and 5 <sup>1</sup>  | DIMMs 1 and 4, 13 and 16, 33 and 36, 45 and 48, 9 and 12 <sup>1</sup>   |
| 6                              | DIMMs 1 and 4, 9 and 12, 2 and 5, 8 and 11, 3 and 6, 7 and 10 <sup>1</sup> | DIMMs 1 and 4, 13 and 16, 9 and 12, 21 and 24, 2 and 5, and 14 and 17 <sup>1</sup>                               | DIMMs 1 and 4, 13 and 16, 33 and 36, 45 and 48, 9 and 12, 21 and 24 <sup>1</sup>                                |
| 7                              |  | DIMMs 1 and 4, 13 and 16, 9 and 12, 21 and 24, 2 and 5, and 14 and 17, 8 and 11 <sup>1</sup>                     | DIMMs 1 and 4, 13 and 16, 33 and 36, 45 and 48, 9 and 12, 21 and 24, 25 and 28 <sup>1</sup>                     |
| 8                              |  | DIMMs 1 and 4, 13 and 16, 9 and 12, 21 and 24, 2 and 5, and 14 and 17, 8 and 11, 20 and 23 <sup>1</sup>          | DIMMs 1 and 4, 13 and 16, 33 and 36, 45 and 48, 9 and 12, 21 and 24, 25 and 28, 37 and 40 <sup>1</sup>          |
| 9                              |  | DIMMs 1 and 4, 13 and 16, 9 and 12, 21 and 24, 2 and 5, and 14 and 17, 8 and 11, 20 and 23, 3 and 6 <sup>1</sup> | DIMMs 1 and 4, 13 and 16, 33 and 36, 45 and 48, 9 and 12, 21 and 24, 25 and 28, 37 and 40, 2 and 5 <sup>1</sup> |

Table 14. DIMM population sequence for mirrored-channel mode (continued)

| Number of DIMM pairs installed | 1 microprocessor installed | 2 microprocessor installed   | 4 microprocessor installed   |
|--------------------------------|----------------------------|--|--|
| 10                             |                            | DIMMs 1 and 4, 13 and 16, 9 and 12, 21 and 24, 2 and 5, and 14 and 17, 8 and 11, 20 and 23, 3 and 6, 15 and 18 <sup>1</sup>                      | DIMMs 1 and 4, 13 and 16, 33 and 36, 45 and 48, 9 and 12, 21 and 24, 25 and 28, 37 and 40, 2 and 5, 14 and 17 <sup>1</sup>   |
| 11                             |                            | DIMMs 1 and 4, 13 and 16, 9 and 12, 21 and 24, 2 and 5, and 14 and 17, 8 and 11, 20 and 23, 3 and 6, 15 and 18, 7 and 10 <sup>1</sup>            | DIMMs 1 and 4, 13 and 16, 33 and 36, 45 and 48, 9 and 12, 21 and 24, 25 and 28, 37 and 40, 2 and 5, 14 and 17, 32 and 35 <sup>1</sup>  |
| 12                             |                            | DIMMs 1 and 4, 13 and 16, 9 and 12, 21 and 24, 2 and 5, and 14 and 17, 8 and 11, 20 and 23, 3 and 6, 15 and 18, 7 and 10, 19 and 22 <sup>1</sup> | DIMMs 1 and 4, 13 and 16, 33 and 36, 45 and 48, 9 and 12, 21 and 24, 25 and 28, 37 and 40, 2 and 5, 14 and 17, 32 and 35, 44 and 47 <sup>1</sup>   |
| 13                             |                            |  | DIMMs 1 and 4, 13 and 16, 33 and 36, 45 and 48, 9 and 12, 21 and 24, 25 and 28, 37 and 40, 2 and 5, 14 and 17, 32 and 35, 44 and 47, 8 and 11 <sup>1</sup>   |
| 14                             |                            |  | DIMMs 1 and 4, 13 and 16, 33 and 36, 45 and 48, 9 and 12, 21 and 24, 25 and 28, 37 and 40, 2 and 5, 14 and 17, 32 and 35, 44 and 47, 8 and 11, 20 and 23 <sup>1</sup>                                |
| 15                             |                            |  | DIMMs 1 and 4, 13 and 16, 33 and 36, 45 and 48, 9 and 12, 21 and 24, 25 and 28, 37 and 40, 2 and 5, 14 and 17, 32 and 35, 44 and 47, 8 and 11, 20 and 23, 26 and 29 <sup>1</sup>                     |
| 16                             |                            |  | DIMMs 1 and 4, 13 and 16, 33 and 36, 45 and 48, 9 and 12, 21 and 24, 25 and 28, 37 and 40, 2 and 5, 14 and 17, 32 and 35, 44 and 47, 8 and 11, 20 and 23, 26 and 29, 38 and 41 <sup>1</sup>          |
| 17                             |                            |  | DIMMs 1 and 4, 13 and 16, 33 and 36, 45 and 48, 9 and 12, 21 and 24, 25 and 28, 37 and 40, 2 and 5, 14 and 17, 32 and 35, 44 and 47, 8 and 11, 20 and 23, 26 and 29, 38 and 41, 3 and 6 <sup>1</sup> |

Table 14. DIMM population sequence for mirrored-channel mode (continued)

| Number of DIMM pairs installed   | 1 microprocessor installed | 2 microprocessor installed | 4 microprocessor installed  |
|--|----------------------------|----------------------------|---|
| 18   |                            |                            | DIMMs 1 and 4, 13 and 16, 33 and 36, 45 and 48, 9 and 12, 21 and 24, 25 and 28, 37 and 40, 2 and 5, 14 and 17, 32 and 35, 44 and 47, 8 and 11, 20 and 23, 26 and 29, 38 and 41, 3 and 6, 15 and 18 <sup>1</sup> |
| 1. For mirrored-channel mode, the DIMM pair must be identical in size, type, and rank count. |                            |                            |   |

To install a DIMM, complete the following steps:

- Step 1. Remove the cover (see “Removing the compute node cover” on page 836).
- Step 2. Read the documentation that comes with the DIMM.
- Step 3. Remove the air baffle installed over the DIMM connector.

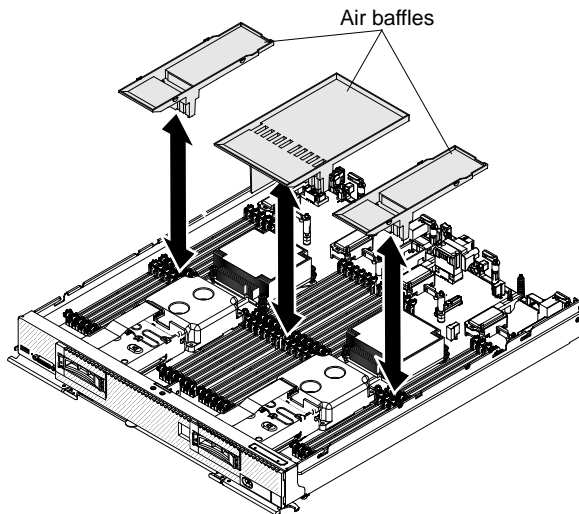

- Step 4. Locate the DIMM connectors (see “System-board connectors” on page 18). Determine which DIMM connector you want to install the DIMM in.
- Step 5. Touch the static-protective package that contains the DIMM to any *unpainted* metal surface on the Flex System chassis or any *unpainted* metal surface on any other grounded rack component in the rack in which you are installing the DIMM for at least 2 seconds; then, remove the DIMM from its package.

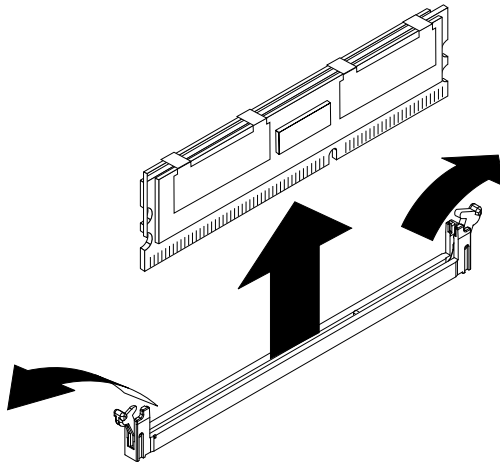

- Step 6. Make sure that both retaining clips on the DIMM connector are in the open position.
- Step 7. Turn the DIMM so that the DIMM keys align correctly with the DIMM connector on the system board.

**Attention:** To avoid breaking the retaining clips or damaging the DIMM connector, handle the clips gently.

- Step 8. Press the DIMM into the DIMM connector. The retaining clips lock the DIMM into the connector.
- Step 9. Make sure that the small tabs on the retaining clips engage the notches on the DIMM. If there is a gap between the DIMM and the retaining clips, the DIMM has not been correctly installed. Press the DIMM firmly into the connector, and then press the retaining clips toward the DIMM until the tabs are fully seated. When the DIMM is correctly installed, the retaining clips are parallel to the sides of the DIMM.

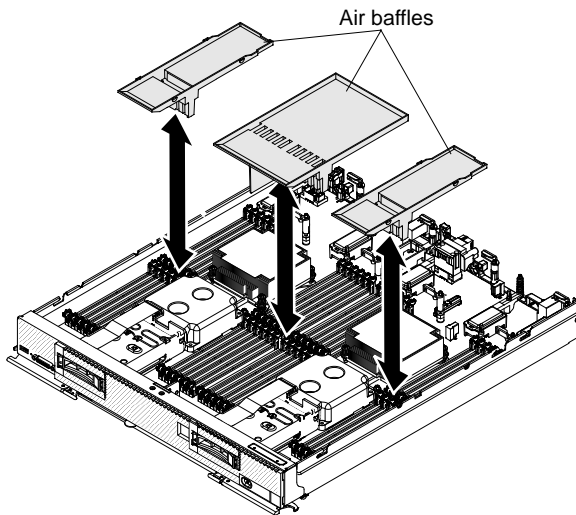

- Step 10. Install the air baffle over the DIMM connector.

**Attention:**

- Install the air baffles with the arrow indicating air flow direction pointing to the rear of the compute node.
- To maintain proper system cooling, do not operate the compute node without air baffles installed over the DIMM connectors.

After you install the DIMM, complete the following steps:

1. Install the cover onto the compute node (see “Installing the compute node cover” on page 838 for instructions).
2. Install the compute node into the chassis (see “Installing a compute node in a chassis” on page 829 for instructions).

## Removing the front handle

Use this information to remove the front handle.

Before you remove the front handles, complete the following steps:

1. Read “Safety” on page iii and “Installation guidelines” on page 827.
2. If the compute node is installed in a Flex System chassis, remove it (see “Removing a compute node from a chassis” on page 828 for instructions).
3. Carefully lay the compute node on a flat, static-protective surface with the cover side down, orienting the compute node with the bezel pointing toward you.

To remove the front handles, complete the following steps.

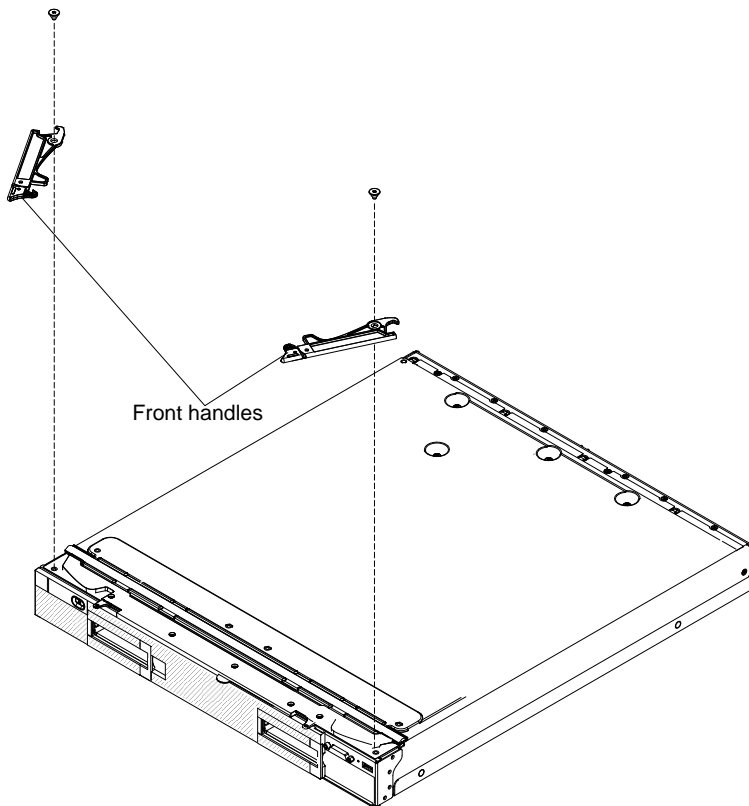

Step 1. Locate the screws that attach the handles to the compute node.

Step 2. Using a T8 Torx screwdriver, remove the screw from each front handle and save the screw in a safe place. Use the same screws when you install the front handles.

If you are instructed to return the front handles, follow all packaging instructions, and use any packaging materials for shipping that are supplied to you.

## Installing the front handles

Use this information to install the front handle.



Before you install the front handles, complete the following steps:

1. Read “Safety” on page iii and “Installation guidelines” on page 827.
2. If the compute node is installed in a Flex System chassis, remove it (see “Removing a compute node from a chassis” on page 828 for instructions).
3. Carefully lay the compute node on a flat, static-protective surface with the cover side down, orienting the compute node with the bezel pointing toward you.

To install the front handles, complete the following steps.

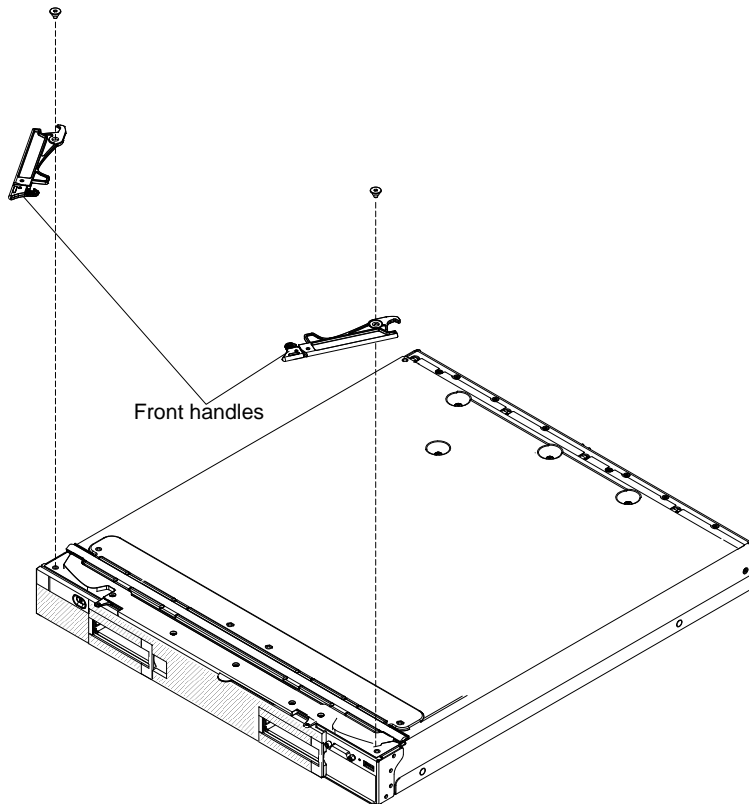

- Step 1. Orient the front handles so that the blue release latches are toward the middle of the compute node.
- Step 2. Align the hole in the handles with the holes on the compute node where the handles are installed.
- Step 3. Using a T8 Torx screwdriver, install the screw that secures each handle. Use the screws that you removed when you removed the handles.

After you install the front handles, install the compute node into the chassis (see “Installing a compute node in a chassis” on page 829 for instructions).

## Removing the hard disk drive backplane

Use this information to remove the hard disk drive backplane.

**Note:** This procedure should be performed only by trained service technicians.

Before you remove the hard disk drive backplane, complete the following steps:

1. Read “Safety” on page iii and “Installation guidelines” on page 827.

2. If the compute node is installed in a Flex System chassis, remove it (see “Removing a compute node from a chassis” on page 828 for instructions).
3. Carefully lay the compute node on a flat, static-protective surface, orienting the compute node with the bezel pointing toward you.

To remove the hard disk drive backplane, complete the following steps.

- Step 1. Remove the cover (see “Removing the compute node cover” on page 836).
- Step 2. For the hard disk drive backplane that you have to replace, disconnect the applicable hard disk drive by pressing the release latch (orange) on the hard disk drive to release the drive handle; then, use the drive handle to slide the hard disk drive approximately 12 mm (0.5 in.) out of the bay. See “Removing a hot-swap hard disk drive” on page 856).
- Step 3. To disconnect the cable from the hard disk drive backplane that you removed, pull the connector clip away from the cable to unhook the clip from the backplane as you push the cable connector toward the rear of the compute node **1**.

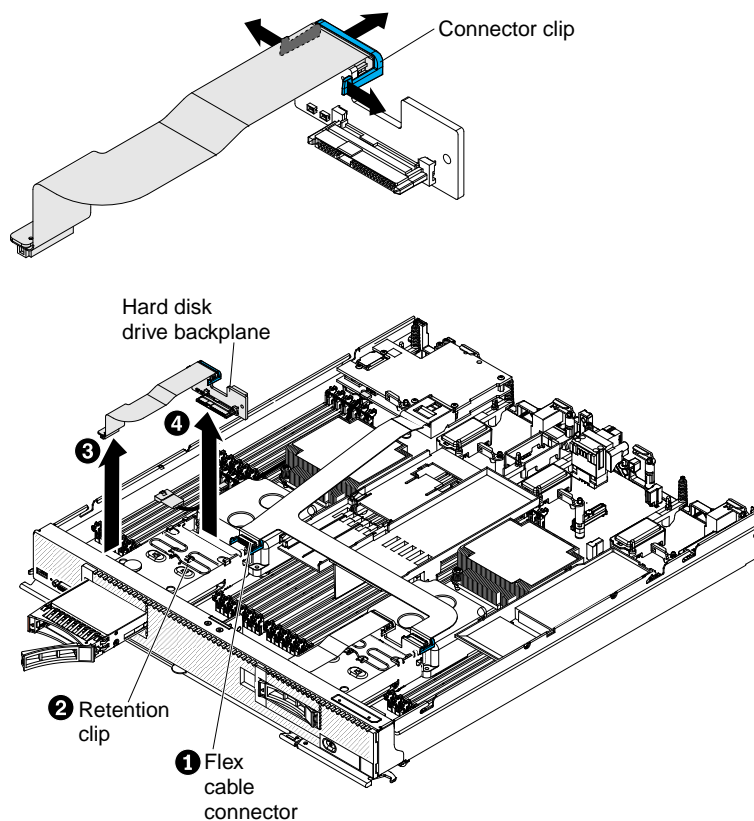

- Step 4. Push the retention clip on the hard disk drive cage toward the rear of the compute node to release it from under the tab; then, slide the retention clip toward the front of the compute node to release the hard disk drive backplane **2**.
- Step 5. Disconnect the hard disk drive backplane cable from the system board **3**.
- Step 6. Lift out the hard disk drive backplane and cable. It might be necessary to pull the backplane toward the front of the compute node before you lift it out of the compute node **4**.

If you are instructed to return the hard disk drive backplane, follow all packaging instructions, and use any packaging materials for shipping that are supplied to you.

## Installing the hard disk drive backplane

Use this information to install the hard disk drive backplane.

**Note:** This procedure should be performed only by trained service technicians.

Before you install the hard disk drive backplane, complete the following steps:

1. Read “Safety” on page iii and “Installation guidelines” on page 827.
2. If the compute node is installed in a Flex System chassis, remove it (see “Removing a compute node from a chassis” on page 828 for instructions).
3. Carefully lay the compute node on a flat, static-protective surface, orienting the compute node with the bezel pointing toward you.

To install the hard disk drive backplane, complete the following steps.

Step 1. Remove the cover (see “Removing the compute node cover” on page 836).

Step 2. To connect the backplane cable to the new hard disk drive backplane, hold open the connector clip while you push the cable connector into the backplane cable connector. Make sure that the connector clip clicks into place around the backplane.

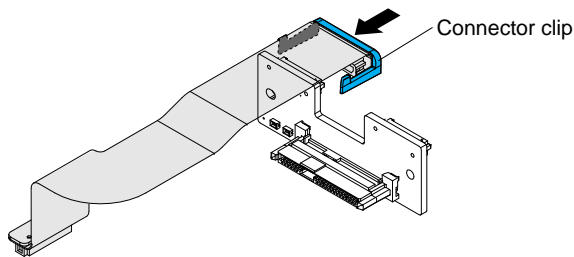

**Note:** Pull the retention clip forward when you install the backplane.

Step 3. Align the new hard disk drive backplane with the hard disk drive cage and the connector on the system board and press the backplane into position until it is fully seated in the connector **1**.

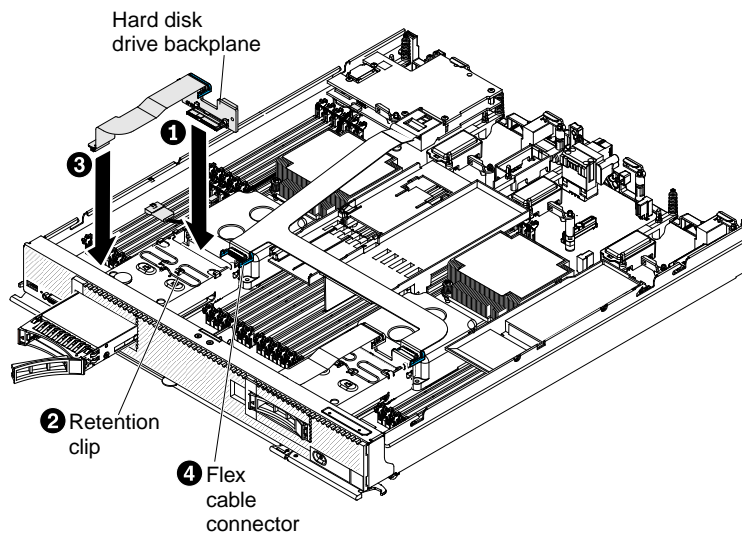

Step 4. Push the retention clip on the hard disk drive cage toward the rear of the compute node and under the tab to secure the backplane **2**.

Step 5. Connect the hard disk drive backplane cable to the system board **3**.

- Step 6. Connect the flex cable to the hard disk drive backplane connector 4.
- Step 7. Reconnect the hard disk drive by sliding it fully into the bay and closing the drive tray handle, see “Installing a hot-swap hard disk drive” on page 856
- Step 8. Install the cover onto the compute node (see “Installing the compute node cover” on page 838 for instructions).
- Step 9. Install the compute node into the chassis (see “Installing a compute node in a chassis” on page 829 for instructions).

After you install the hard disk drive backplane, complete the following steps:

1. Install the cover onto the compute node (see “Installing the compute node cover” on page 838 for instructions).
2. Install the compute node into the chassis (see “Installing a compute node in a chassis” on page 829 for instructions).

## Removing a hot-swap hard disk drive

Use this information to remove a hot-swap hard disk drive.

Before you remove a hot-swap hard disk drive, complete the following steps:

1. Back up all important data before you make changes to hard disk drives.
2. Read “Safety” on page iii and “Installation guidelines” on page 827.

The compute node has two hard disk drive bays for installing or removing hot-swap hard disk devices. To remove a hot-swap hard disk drive, complete the following steps.

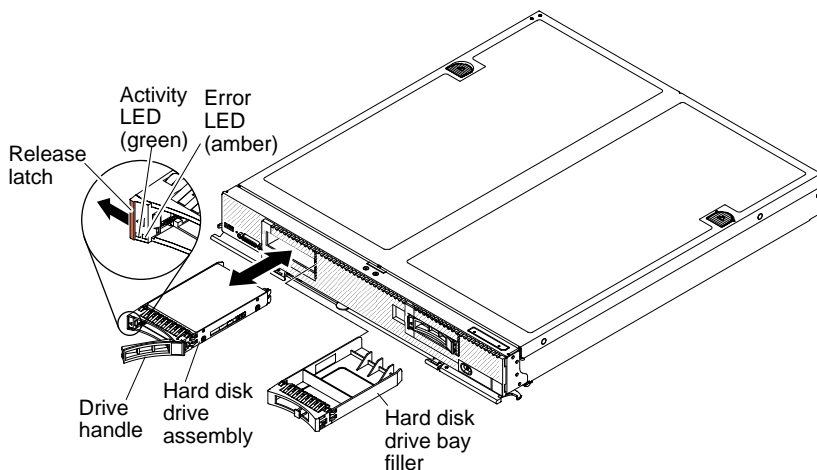

- Step 1. Press the release latch (orange) on the hard disk drive to release the drive handle.
- Step 2. Pull the release handle to remove the drive from the bay.

If you are instructed to return the hard disk drive, follow all packaging instructions, and use any packaging materials for shipping that are supplied to you.

## Installing a hot-swap hard disk drive

Use this information to install a hot-swap hard disk drive.

Before you install the hot-swap hard disk drive, read “Safety” on page iii and “Installation guidelines” on page 827.

The compute node has two SAS or SATA hard disk drive bays for installing hot-swap hard disk drives, such as hot-swap SAS hard disk drives. One hard disk drive might already be installed in the compute node in hard disk drive bay 0. If the compute node is equipped with one hard disk drive, you can install an additional drive in hard disk drive bay 1. The compute node supports using RAID 0 or RAID 1 when two hard disk drives of the same interface type are installed. See “Configuring a RAID array” on page 35 for information about RAID configuration.

To install a hot-swap hard disk drive or hard disk drive bay filler, complete the following steps.

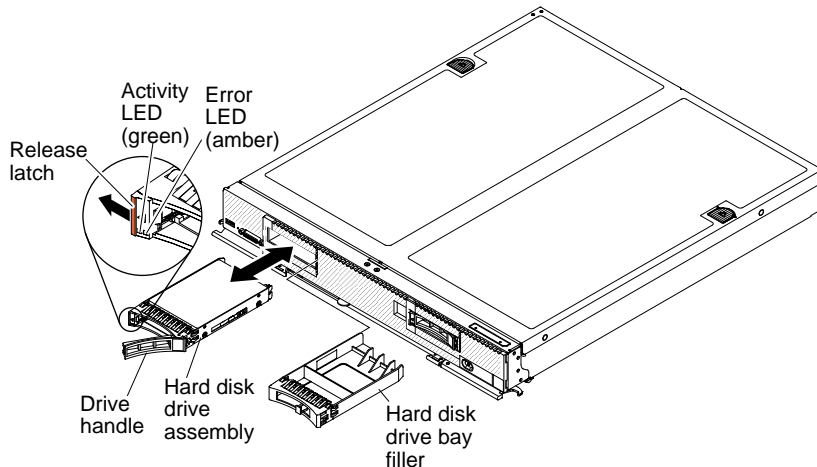

- Step 1. Identify the hard disk drive bay (hard disk drive bay 0 or hard disk drive bay 1) in which you plan to install the hot-swap hard disk drive.
- Step 2. If a hard disk drive bay filler is installed, remove it from the compute node by pulling the release lever and sliding the filler away from the compute node.
- Step 3. Touch the static-protective package that contains the hot-swap hard disk drive to any *unpainted* metal surface on the Flex System chassis or any *unpainted* metal surface on any other grounded rack component; then, remove the hard disk drive from the package.
- Step 4. Open the release lever on the hot-swap hard disk drive and slide the drive into the bay until it is firmly seated in the connector.
- Step 5. Lock the hot-swap hard disk drive into place by closing the release lever.
- Step 6. Check the hard disk drive status LEDs to make sure that the hard disk drive is operating correctly.

See “Configuring a RAID array” on page 35 for information about SAS RAID configuration.

## Removing an I/O expansion adapter

Use this information to remove an I/O expansion adapter.

Before you remove the I/O expansion adapter, complete the following steps:

1. Read “Safety” on page iii and “Installation guidelines” on page 827.
2. If the compute node is installed in a Flex System chassis, remove it (see “Removing a compute node from a chassis” on page 828 for instructions).

3. Carefully lay the compute node on a flat, static-protective surface, orienting the compute node with the bezel pointing toward you.

To remove an I/O expansion adapter, complete the following steps.

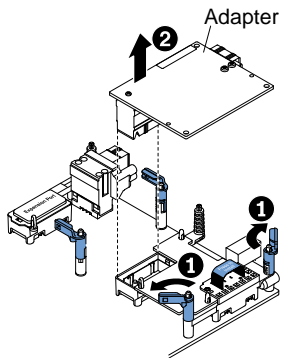

- Step 1. Remove the cover (see “Removing the compute node cover” on page 836).
- Step 2. Locate the I/O expansion adapter connectors (see “System-board layouts” on page 18).
- Step 3. Open the retention clips 1.
- Step 4. Lift the I/O expansion adapter from the connector and remove the I/O expansion adapter from the compute node 2. You might find it helpful to rock the adapter back and forth to disengage the adapter.

If you are instructed to return the I/O expansion adapter, follow all packaging instructions, and use any packaging materials for shipping that are supplied to you.

## Installing an I/O expansion adapter

Use this information to install an I/O expansion adapter.

Before you install an I/O expansion adapter, complete the following steps:

1. Read “Safety” on page iii and “Installation guidelines” on page 827.
2. If the compute node is installed in a Flex System chassis, remove it (see “Removing a compute node from a chassis” on page 828 for instructions).
3. Carefully lay the compute node on a flat, static-protective surface, orienting the compute node with the bezel pointing toward you.
4. If your adapter was previously configured, backup or record its configuration information, if possible, before replacing the adapter. See the documentation for your adapter for information and instructions.

This component can be installed as an optional device or as a CRU. The installation procedure is the same for the optional device and the CRU.

To install an I/O expansion adapter, complete the following steps.

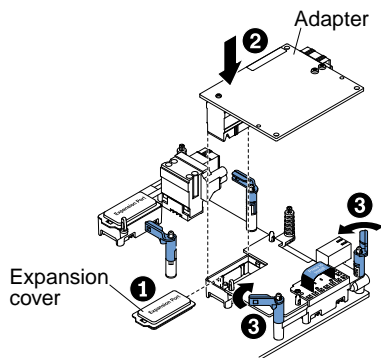

- Step 1. Remove the cover (see “Removing the compute node cover” on page 836).
- Step 2. Locate the I/O expansion connectors (see “System-board connectors” on page 18).
- Step 3. Remove the expansion cover **1** from the connector, if one is present.
- Step 4. Touch the static-protective package that contains the adapter to any *unpainted* metal surface on the Flex System chassis or any *unpainted* metal surface on any other grounded rack component; then, remove the adapter from the package.
- Step 5. Open the retention clips if they are closed.
- Step 6. Orient the connector on the expansion adapter with the I/O expansion connector and alignment pins on the system board **2**; then, press the adapter into the I/O expansion connector.
- Step 7. Firmly press on the indicated locations to seat the expansion adapter in the connector and over the alignment pins.
- Step 8. Close the retention clips **3**.
- Step 9. If you are replacing a ServeRAID adapter, import your RAID configuration to the replacement adapter as a foreign configuration. See the ServeRAID-M Software User Guide at <https://support.lenovo.com/us/en/documents/migr-5086126> for instructions.

After you install the I/O expansion adapter, complete the following steps:

1. Install the cover onto the compute node (see “Installing the compute node cover” on page 838 for instructions).
2. Install the compute node into the chassis (see “Installing a compute node in a chassis” on page 829 for instructions).
3. See the documentation that comes with the expansion adapter for device-driver and configuration information to complete the installation.

## Removing the light path diagnostics panel

Use this information to remove the light path diagnostics panel.

Before you remove the light path diagnostics panel, complete the following steps:

1. Read “Safety” on page iii and “Installation guidelines” on page 827.
2. If the compute node is installed in a Flex System chassis, remove it (see “Removing a compute node from a chassis” on page 828 for instructions).
3. Carefully lay the compute node on a flat, static-protective surface, orienting the compute node with the bezel pointing toward you.

To remove the light path diagnostics panel, complete the following steps.

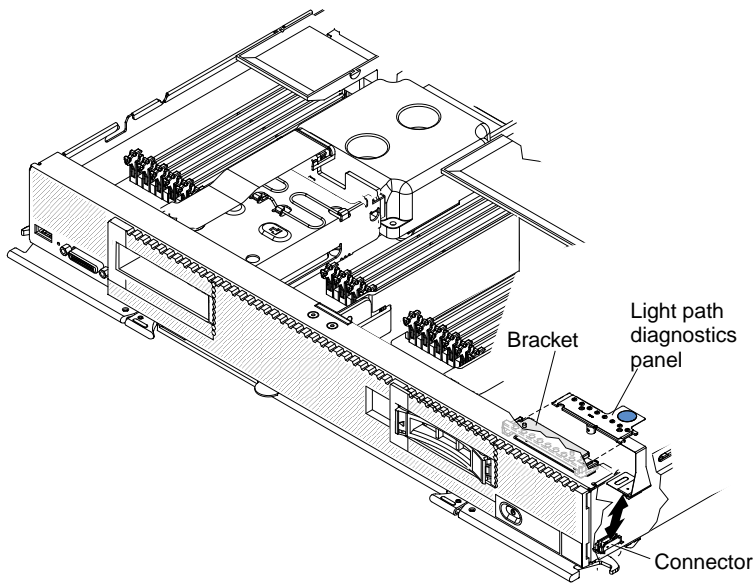

- Step 1. Remove the cover (see “Removing the compute node cover” on page 836).
- Step 2. Pull the light path diagnostics panel out of the bracket.
- Step 3. Disconnect the cable from the system board.
- Step 4. Lift the light path diagnostics panel from the compute node.

If you are instructed to return the light path diagnostics panel, follow all packaging instructions, and use any packaging materials for shipping that are supplied to you.

## Installing the light path diagnostics panel

Use this information to install the light path diagnostics panel.

Before you install the light path diagnostics panel, complete the following steps:

1. Read “Safety” on page iii and “Installation guidelines” on page 827.
2. If the compute node is installed in a Flex System chassis, remove it (see “Removing a compute node from a chassis” on page 828 for instructions).
3. Carefully lay the compute node on a flat, static-protective surface, orienting the compute node with the bezel pointing toward you.

To install a light path diagnostics panel, complete the following steps.



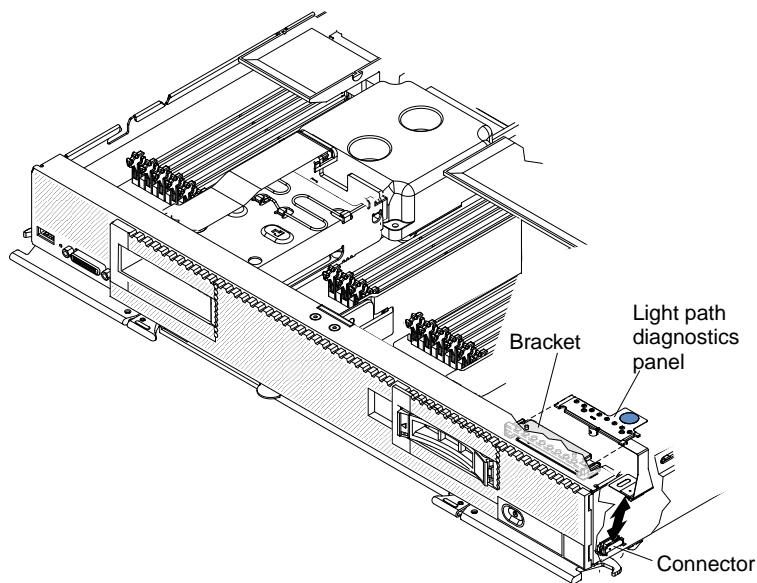

- Step 1. Remove the cover (see “Removing the compute node cover” on page 836).
- Step 2. Connect the cable on the system board.
- Step 3. Align the light path diagnostics panel with the bracket.
- Step 4. Press the light path diagnostics panel securely into the bracket.

After you install the light path diagnostics panel, complete the following steps:

1. Install the cover onto the compute node (see “Installing the compute node cover” on page 838 for instructions).
2. Install the compute node into the chassis (see “Installing a compute node in a chassis” on page 829 for instructions).

## Removing the USB flash drive

Use this information to remove the USB flash drive.

Before you remove the USB flash drive, complete the following steps:

1. Read “Safety” on page iii and “Installation guidelines” on page 827.
2. If the compute node is installed in a Flex System chassis, remove it (see “Removing a compute node from a chassis” on page 828 for instructions).
3. Carefully lay the compute node on a flat, static-protective surface, orienting the compute node with the bezel pointing away from you.

To remove the USB flash drive, complete the following steps.

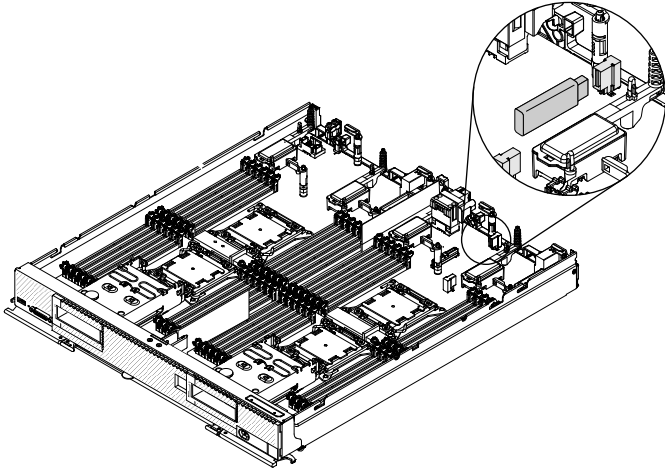

Step 1. Remove the cover (see “Removing the compute node cover” on page 836).

Step 2. Locate the USB connectors on the system board.

**Note:** You might have to remove an I/O expansion adapter to remove the USB flash drive. See “Removing an I/O expansion adapter” on page 857 for instructions.

Step 3. Pull the USB flash drive out of the connector.

If you are instructed to return the USB flash drive, follow all packaging instructions, and use any packaging materials for shipping that are supplied to you.

## Installing the USB flash drive

Use this information to install the USB flash drive.

Before you install the USB flash drive, complete the following steps:

1. Read “Safety” on page iii and “Installation guidelines” on page 827.
2. If the compute node is installed in a Flex System chassis, remove it (see “Removing a compute node from a chassis” on page 828 for instructions).
3. Carefully lay the compute node on a flat, static-protective surface, orienting the compute node with the bezel pointing toward you.

This component can be installed as an optional device or as a CRU. The installation procedure is the same for the optional device and the CRU.

To install the USB flash drive, complete the following steps.

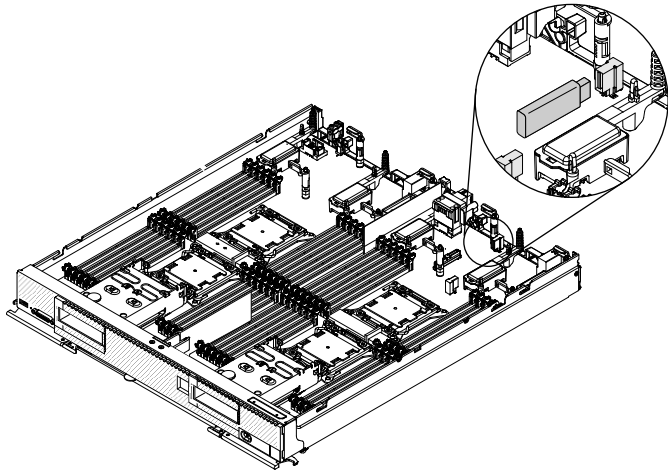

Step 1. Remove the cover (see “Removing the compute node cover” on page 836).

Step 2. Locate the USB connectors on the system board.

**Note:** You might have to remove an I/O expansion adapter install the USB flash drive. See “Removing an I/O expansion adapter” on page 857 for instructions.

Step 3. Push the USB flash drive into the connector.

After you install the USB flash drive, complete the following steps:

1. Install the cover onto the compute node (see “Installing the compute node cover” on page 838 for instructions).
2. Install the compute node into the chassis (see “Installing a compute node in a chassis” on page 829 for instructions).

---

## Removing and replacing Tier 2 customer replaceable units (CRUs)

Use this information for removing and replacing Tier 2 CRUs.

You may install a Tier 2 CRU yourself or request Lenovo to install it, at no additional charge, under the type of warranty service that is designated for the compute node. A Tier 2 CRU must be installed only by trained service technicians.

## Removing and replacing the base assembly

Use this information to remove and replace the base assembly.

### Notes:

- This procedure should be performed only by trained service technicians.
- If possible, back up all compute node settings, including the settings for any options installed in the compute node. You can backup and restore system settings using the Advanced Setup Utility (ASU) (see <https://support.lenovo.com/us/en/documents/LNVO-ASU> for information and instructions).

Before you replace the base assembly, complete the following steps:

1. Read “Safety” on page iii and “Installation guidelines” on page 827.
2. If the compute node is installed in a chassis, remove it (see “Removing a compute node from a chassis” on page 828 for instructions).

3. Carefully lay the replacement base assembly (base assembly FRU) and the defective base assembly (defective node) side-by-side on a flat, static-protective surface.
4. Obtain the following for use during the replacement procedure (see Chapter 5 “Parts listing, Types 7167 and 2590” on page 51).
  - Alcohol wipes
  - Thermal grease

**Important:** When you replace the base assembly, you must update the compute node with the latest firmware or restore the preexisting firmware. Make sure that you have the latest firmware or a copy of the preexisting firmware before you proceed. See “Updating firmware and device drivers” on page 23 for more information.

See “System-board layouts” on page 18 for more information about the locations of the connectors, switches, and LEDs on the system board.

To remove and replace the base assembly, complete the following steps:

**Important:** To avoid damage when replacing a defective base assembly, transfer internal components between the defective base assembly and the replacement base assembly one at a time. Unless otherwise noted, install each internal component in the replacement base assembly immediately after removing it from the defective base assembly.

Step 1. Remove any storage drives, optional drive components, and hard disk drive bay fillers from the defective based assembly and set them aside on a static-protective surface. (see “Removing a hot-swap hard disk drive” on page 856).

Step 2. Remove the bezel from the defective base assembly and immediately install it on the replacement base assembly (see “Removing the bezel” on page 833 and “Installing the bezel” on page 834).

**Note:** If your compute node has an RFID tag, it is already attached to the bezel.

Step 3. Remove the covers from both compute nodes (see “Removing the compute node cover” on page 836). Keep the cover that comes with the replacement base assembly for reference and re-install it on the defective base assembly prior to returning the defective base assembly.

Step 4. Remove hard disk drive backplane from the defective base assembly and immediately install it in the replacement base assembly (see “Removing the hard disk drive backplane” on page 853 and “Installing the hard disk drive backplane” on page 855).

**Note:** Install the storage drives in the same bay locations from which they were removed.

Step 5. Install any removed storage drives, optional drive components, and hard disk drive bay fillers into the replacement base assembly (see “Installing a hot-swap hard disk drive” on page 856).

Step 6. Remove the DIMM air baffles from defective base assembly and set them aside.

**Attention:**

- Remove and install only one microprocessor at a time.
- When removing or installing a microprocessor, protect the other microprocessor socket with a microprocessor heat sink filler.
- When transferring a microprocessor to a replacement base assembly, install the microprocessor heat sink filler in the defective base assembly immediately after installing the microprocessor in the replacement base assembly.

Step 7. Transfer microprocessor 1 (left rear microprocessor) and its heat sink from the defective base assembly to the replacement base assembly. Use the microprocessor installation tool that comes with the replacement base assembly to remove the microprocessor from the defective base assembly and install it immediately in the replacement base assembly.

- a. Use a screwdriver to loosen the screw on one side of the heat sink to break the seal with the microprocessor.
- b. Use a screwdriver to loosen the screws on the heat sink, rotating each screw two full turns until each screw is loose.
- c. Gently pull the heat sink from the microprocessor.

**Attention:** Do not touch the thermal material on the bottom of the heat sink. Touching the thermal material will contaminate it.

- d. Identify which release lever is labeled as the first release lever to open, and open it.

**Attention:** Do not use any tools or sharp objects to lift the release levers on the microprocessor socket. Doing so might result in permanent damage to the system board.

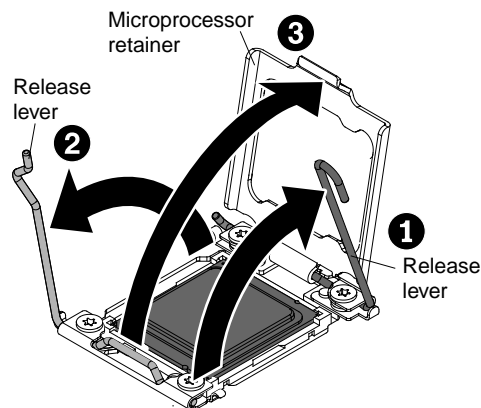

- e. Open the second release lever on the microprocessor socket.
- f. Open the microprocessor retainer.
- g. Select the empty installation tool and ensure that the handle is in the open position. If the installation tool handle is not in the open position, use the following instructions for your installation tool:
  - If using Installation Tool A, twist the microprocessor installation tool handle counterclockwise to the open position.
  - If using Installation Tool B, 1) lift the interlock latch and hold it up while you 2) twist the microprocessor installation tool handle counterclockwise to the open position, and then release the interlock latch. The following illustration of the installation tool shows the location of the interlock latch and counterclockwise rotation of the handle before loading the microprocessor.

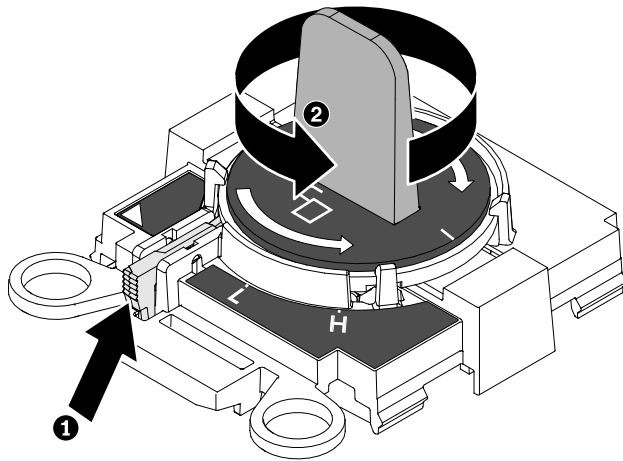

- h. Align the installation tool with the screws, as shown in the following graphic, and lower the installation tool on the microprocessor. The installation tool rests flush on the socket only when it is aligned correctly.

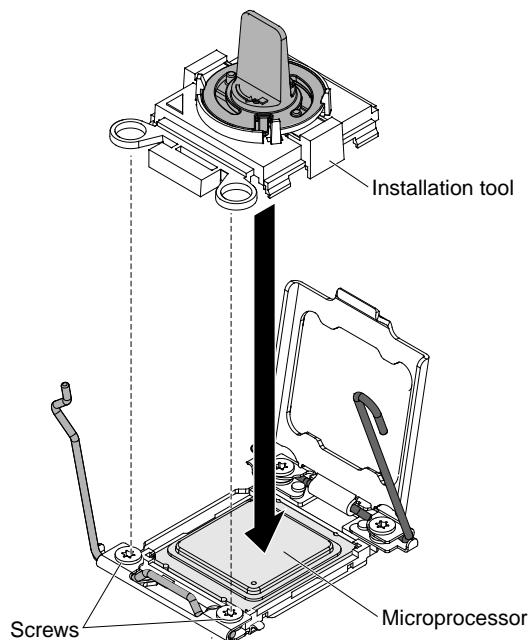

- i. Using the following instructions for your installation tool, remove the microprocessor.
- If using Installation Tool A, gently twist the handle clockwise to the closed position and lift the microprocessor out of the socket.
  - If using Installation Tool B, gently twist the handle of the installation tool clockwise until it locks in the “H” or “L” position, depending on the size of microprocessor, and then lift the microprocessor out of the socket.

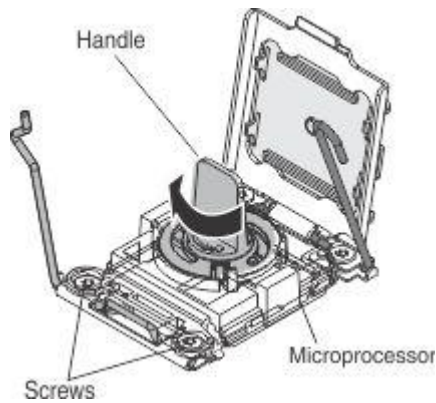

**Attention:** Do not touch the connectors on the microprocessor and the microprocessor socket.

- j. Open the packaging that contains the new microprocessor installation tool assembly and carefully remove the installation tool assembly from the package.

**Note:** Do not touch the microprocessor contacts. Contaminants on the microprocessor contacts, such as oil from your skin, can cause connection failures between the contacts and the socket.

- k. Remove the microprocessor protective cover if one is present.

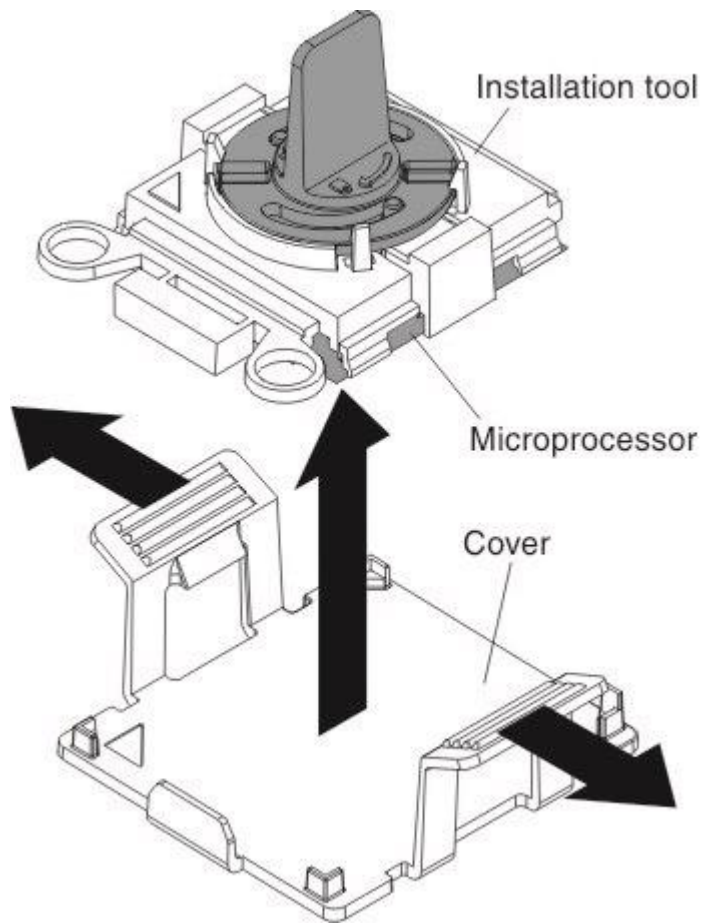

- l. Align the installation tool with the microprocessor socket. The installation tool rests flush on the socket only if it is properly aligned.

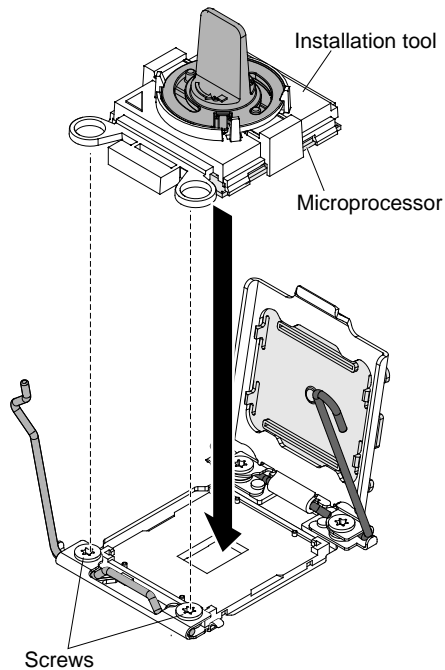

- m. Install the microprocessor using the following instructions for your installation tool.
- If using Installation Tool A, twist the handle on the microprocessor tool assembly counterclockwise to the open position to insert the microprocessor into the socket, and lift the installation tool out of the socket.
  - If using Installation Tool B, twist the handle of the installation tool assembly counterclockwise until the microprocessor is inserted into the socket, and lift the installation tool out of the socket. The following illustration shows the tool handle in the open position.

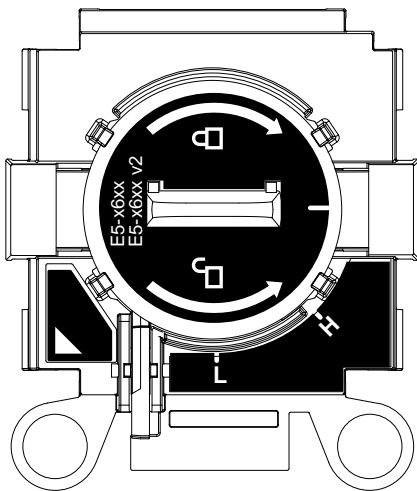

**Attention:**

- Do not press the microprocessor into the socket.
- Make sure that the microprocessor is aligned correctly in the socket before you try to close the microprocessor retainer.
- Do not touch the thermal grease on the bottom of the heat sink or on top of the microprocessor. Touching the thermal grease will contaminate it.



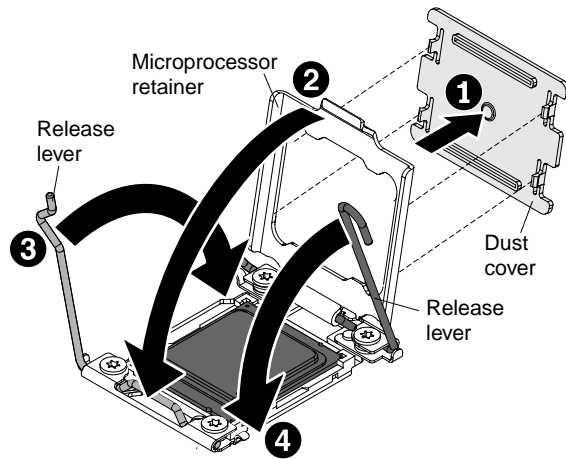

- n. Close the microprocessor retainer on the microprocessor socket.
- o. Identify which release lever is labeled as the first release lever to close, and close it.
- p. Close the second release lever on the microprocessor socket.

**Attention:**

- If you are installing a new heat sink, do not set down the heat sink after you remove the plastic cover.
- Do not touch the thermal material on the bottom of the heat sink. Touching the thermal material will contaminate it.

Step 8. Repeat step 8 for microprocessors 2, 3 and 4, if installed.

Step 9. Remove all of the installed components in the following list from the defective base assembly; then, immediately install them on the replacement base assembly:

- DIMMs. See “Removing a DIMM” on page 839 and “Installing a DIMM ” on page 840.
- Fabric connector. See “Removing a fabric connector” on page 874 and “Installing a fabric connector” on page 875.
- I/O expansion adapters. See “Removing an I/O expansion adapter” on page 857 and “Installing an I/O expansion adapter” on page 858.

Step 10. Install the DIMM air baffles in the replacement base assembly. The DIMM air baffles are required to maintain system cooling.

**Note:** Retaining clips on the DIMM connectors must be in the closed position to install the air baffles.

Step 11. Install the cover that you removed from the original (defective) base assembly onto the replacement base assembly (see “Installing the compute node cover” on page 838 for instructions).

**Important:** The heat sink fillers protect the microprocessor sockets from potential damage during shipping.

Step 12. Make sure that all four microprocessor sockets on defective base assembly have heat sink fillers installed; then, install the cover that came with the replacement base assembly onto the defective base assembly (see “Installing the compute node cover” on page 838 for instructions).

**Note:** Retention clips that secure the I/O expansion adapters must be in the closed position to install the cover.

Step 13. The new base assembly comes with a Repair Identification (RID) tag. Using a ball point pen, transfer the machine type and serial number from the old base assembly to the two labels on the Repair Identification tag; then, place Tag 1 on the label tab (see “Installing a compute node in a

chassis” on page 829) and Tag 2 on the bottom of the compute node. If you installed the new bezel on the new base assembly because the old bezel was damaged and did not transfer the Tag from the old bezel to the new bezel, install Tag 3 on the lower right corner of the new bezel. If you installed the old bezel on the new base assembly or transferred the Tag from the old bezel to the new bezel, discard Tag 3.

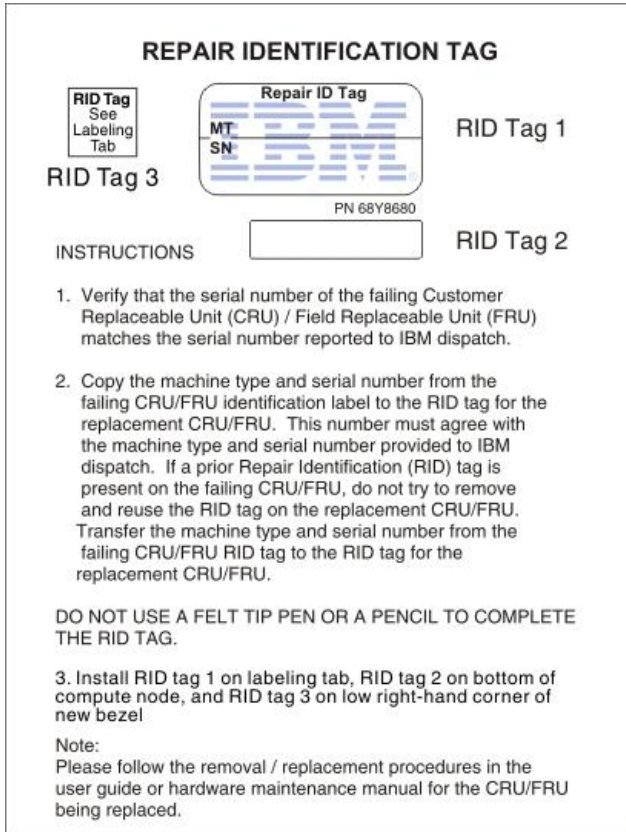

After you transfer components to the replacement base assembly, complete the following steps:

1. Install the compute node in the chassis (see “Installing a compute node in a chassis” on page 829 for instructions).
2. Use the CMM Web Interface to restore the IP address of the compute node IMM. See for more information.

**Note:** If you configured static IP addresses, you will not be able to access the node remotely or from a management device until the IP address of the IMM is restored.

3. Reactivate any Features on Demand features. Instructions for automating the activation of features and installing activation keys is in the *Lenovo Features on Demand Users Guide*. To download the document, go to <https://fod.lenovo.com/lkms>, log in, and click **Help**.
4. Update the Universally Unique Identifier (UUID) and DMI/SMBIOS data with new vital product data (VPD). Use the Advanced Settings Utility to update the UUID and DMI/SMBIOS data (see “Updating the Universally Unique Identifier and DMI/SMBIOS data” on page 32).
5. Update the compute node with the latest firmware or restore the preexisting firmware (see “Updating firmware and device drivers” on page 23 for more information).

If you are instructed to return the defective base assembly, follow all packaging instructions, and use any packaging materials for shipping that are supplied to you.

**Important:** Make sure that both heat-sink fillers are installed on the defective base assembly that you are returning, prior to shipment. Use the heat-sink fillers that were removed from the replacement base assembly when you installed the microprocessors. Do *not* install the microprocessor socket dust covers in the defective base assembly that you are returning.

## Removing the chassis bulkhead

Use this information to remove the chassis bulkhead.

**Note:** This procedure should be performed only by trained service technicians.

Before you remove the chassis bulkhead, complete the following steps:

1. Read “Safety” on page iii and “Installation guidelines” on page 827.
2. If the compute node is installed in a Flex System chassis, remove it (see “Removing a compute node from a chassis” on page 828 for instructions).
3. Carefully lay the compute node on a flat, static-protective surface, orienting the compute node with the bezel pointing toward you.

To remove the chassis bulkhead, complete the following steps.

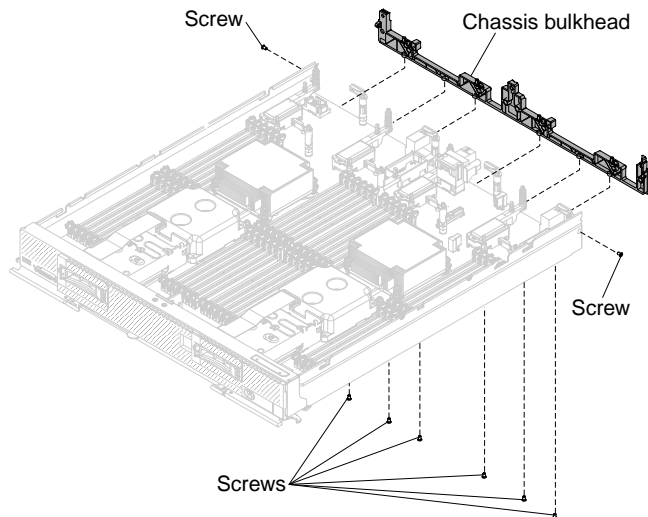

Step 1. Remove the cover (see “Removing the compute node cover” on page 836).

Step 2. Remove the fabric connector (see “Removing a fabric connector” on page 874).

Step 3. Carefully place the chassis on its side with the front handle side up.

**Note:** You might find it helpful to remove the air baffles.

Step 4. Using a T8 Torx screwdriver, remove the screws that secure the bulkhead from the bottom of the chassis.

Step 5. Carefully return the chassis to the bottom-side-down orientation.

Step 6. Using a T8 Torx screwdriver, remove the screws that secure the bulkhead from the sides of the chassis.

Step 7. Lift the chassis bulkhead from the chassis.

If you are instructed to return the chassis bulkhead, follow all packaging instructions, and use any packaging materials for shipping that are supplied to you.

## Installing the chassis bulkhead

Use this information to install the chassis bulkhead.

**Note:** This procedure should be performed only by trained service technicians.

Before you install the chassis bulkhead, complete the following steps:

1. Read “Safety” on page iii and “Installation guidelines” on page 827.
2. If the compute node is installed in a Flex System chassis, remove it (see “Removing a compute node from a chassis” on page 828 for instructions).
3. Carefully lay the compute node on a flat, static-protective surface, orienting the compute node with the bezel pointing toward you.

To install the chassis bulkhead, complete the following steps.

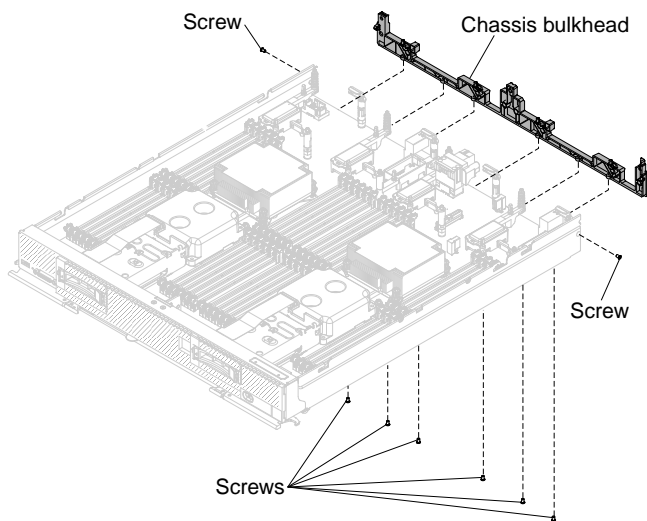

- Step 1. Remove the cover (see “Removing the compute node cover” on page 836).
- Step 2. Remove the fabric connector (see “Removing a fabric connector” on page 874).
- Step 3. Position the bulkhead in the chassis.
- Step 4. Using a T8 Torx screwdriver, install the screws that secure the bulkhead to the sides of the chassis.
- Step 5. Carefully place the chassis on its side with the front handle side up.
- Step 6. Using a T8 Torx screwdriver, install the screws that secure the bulkhead to the bottom of the chassis.
- Step 7. Carefully return the chassis to the bottom-side-down orientation.
- Step 8. Install the fabric connector (see “Installing a fabric connector” on page 875).
- Step 9. Install the air baffles, if you removed them.

### Attention:

- Install the air baffles with the arrow indicating air airflow direction pointing to the rear of the compute node.
- To maintain proper system cooling, do not operate the compute node without air baffles installed over the DIMM connectors.

After you install the chassis bulkhead, complete the following steps:

1. Install the cover onto the compute node (see “Installing the compute node cover” on page 838 for instructions).
2. Install the compute node into the chassis (see “Installing a compute node in a chassis” on page 829 for instructions).

## Removing the hard disk drive cage

Use this information to remove the hard disk drive cage.

**Note:** This procedure should be performed only by trained service technicians.

Before you remove the hard disk drive cage, complete the following steps:

1. Read “Safety” on page iii and “Installation guidelines” on page 827.
2. If the compute node is installed in a Flex System chassis, remove it (see “Removing a compute node from a chassis” on page 828 for instructions).
3. Carefully lay the compute node on a flat, static-protective surface, orienting the compute node with the bezel pointing toward you.

To remove the hard disk drive cage, complete the following steps.

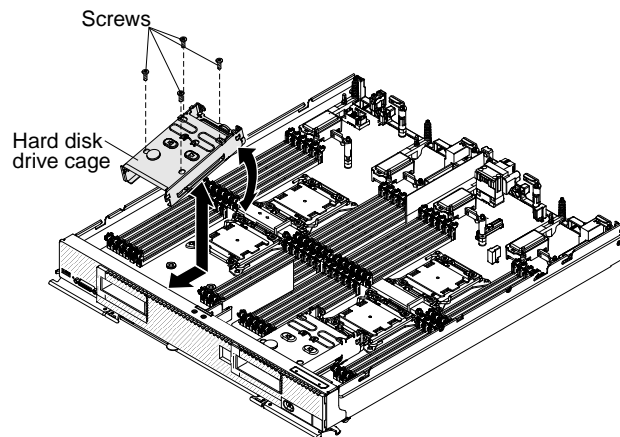

- Step 1. Remove the cover (see “Removing the compute node cover” on page 836).
- Step 2. Remove the hot-swap hard disk drives and hard disk drive bay fillers (see “Removing a hot-swap hard disk drive” on page 856).
- Step 3. Remove the hard disk drive backplane (see “Removing the hard disk drive backplane” on page 853).
- Step 4. Using a T8 Torx screwdriver, remove the four screws from the cage and rotate the cage from under the bezel; then, remove the cage from the compute node at an angle.

If you are instructed to return the hard disk drive cage, follow all packaging instructions, and use any packaging materials for shipping that are supplied to you.

## Installing the hard disk drive cage

Use this information to install the hard disk drive cage.

**Note:** This procedure should be performed only by trained service technicians.

Before you install the hard disk drive cage, complete the following steps:

1. Read “Safety” on page iii and “Installation guidelines” on page 827.

2. If the compute node is installed in a Flex System chassis, remove it (see “Removing a compute node from a chassis” on page 828 for instructions).
3. Carefully lay the compute node on a flat, static-protective surface, orienting the compute node with the bezel pointing toward you.

To install the hard disk drive cage, complete the following steps.

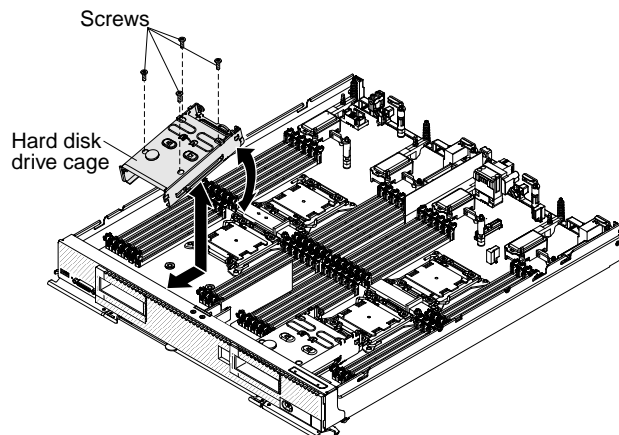

- Step 1. Remove the cover (see “Removing the compute node cover” on page 836).
- Step 2. Position the cage in the bezel at an angle and rotate the cage into position on the system board.
- Step 3. Align the cage with the screw holes on the system board.
- Step 4. Using a T8 Torx screwdriver, install the four screws and secure the cage in the compute node.
- Step 5. Install the hard disk drive backplane (see “Installing the hard disk drive backplane” on page 855).
- Step 6. Insert the hot-swap hard disk drives and hard disk drive bay fillers (see “Installing a hot-swap hard disk drive” on page 856).

After you install the hard disk drive cage, complete the following steps:

1. Install the cover onto the compute node (see “Installing the compute node cover” on page 838 for instructions).
2. Install the compute node into the chassis (see “Installing a compute node in a chassis” on page 829 for instructions).

## Removing a fabric connector

Use this information to remove a fabric connector.

**Note:** This procedure should be performed only by trained service technicians.

Before you remove the fabric connector, complete the following steps:

1. Read “Safety” on page iii and “Installation guidelines” on page 827.
2. If the compute node is installed in a Flex System chassis, remove it (see “Removing a compute node from a chassis” on page 828 for instructions).
3. Carefully lay the compute node on a flat, static-protective surface, orienting the compute node with the bezel pointing toward you.
4. Obtain a #1 Phillips screwdriver.

When you remove the fabric connector, the UEFI firmware holds the Ethernet controller in reset and displays a warning message, if an I/O expansion adapter is not installed in the I/O expansion connector 1 to provide connectivity to the chassis.

To remove a fabric connector, complete the following steps.

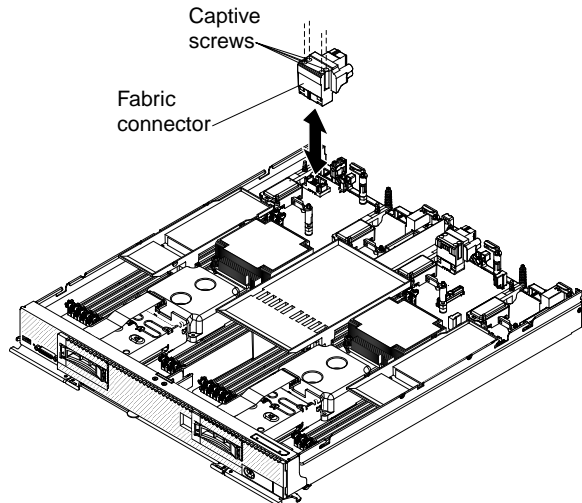

Step 1. Remove the cover (see “Removing the compute node cover” on page 836).

Step 2. Locate the fabric connector on the system board.

Step 3. Using a #1 Phillips screwdriver, loosen the four captive screws that secure the fabric connector.

Step 4. Lift the fabric connector from the system board and store it in a safe place.

If you are instructed to return the fabric connector, follow all packaging instructions, and use any packaging materials for shipping that are supplied to you.

If you have removed the fabric connector to install an I/O expansion adapter in I/O expansion connector 1, keep the fabric connector in a safe place for future use.

## Installing a fabric connector

Use this information to install a fabric connector.

**Note:** This procedure should be performed only by trained service technicians.

Before you install a fabric connector, complete the following steps:

1. Read “Safety” on page iii and “Installation guidelines” on page 827.
2. If the compute node is installed in a Flex System chassis, remove it (see “Removing a compute node from a chassis” on page 828 for instructions).
3. Carefully lay the compute node on a flat, static-protective surface, orienting the compute node with the bezel pointing toward you.
4. Obtain a #1 Phillips screwdriver.

To install a fabric connector, complete the following steps.

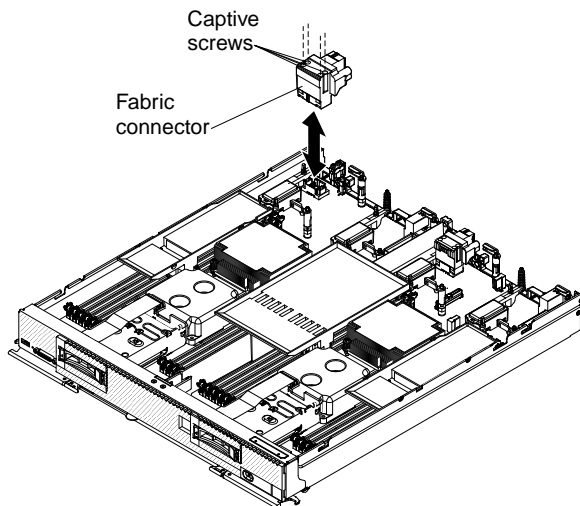

- Step 1. Remove the cover (see “Removing the compute node cover” on page 836).
- Step 2. Locate the fabric connector (see “System-board layouts” on page 18).
- Step 3. Orient the fabric connector on the system board.
- Step 4. Using a #1 Phillips screwdriver, tighten the four captive screws to secure the fabric connector.

**Attention:** Make sure that the fabric connector is secure, but do not overtighten the screws, to avoid damaging the connector.

After you install the fabric connector, complete the following steps:

1. Install the cover onto the compute node (see “Installing the compute node cover” on page 838 for instructions).
2. Install the compute node into the chassis (see “Installing a compute node in a chassis” on page 829 for instructions).

## Removing a microprocessor and heat sink

Use this information to remove a microprocessor and heat sink.

**Note:** This procedure should be performed only by trained service technicians.

Before you remove the microprocessor and heat sink, complete the following steps:

1. Read “Safety” on page iii and “Installation guidelines” on page 827.
2. If the compute node is installed in a Flex System chassis, remove it (see “Removing a compute node from a chassis” on page 828 for instructions).
3. Carefully lay the compute node on a flat, static-protective surface, orienting the compute node with the bezel pointing toward you.

The following notes describe information that you must consider when you remove a microprocessor:

- A socket cover and heat-sink filler or a microprocessor and heat sink must always be installed on microprocessor sockets 1, 3, and 4. Microprocessor socket 2 will only have a socket cover when a microprocessor is not installed. If the compute node has only one microprocessor, it must be installed in microprocessor socket 1.
- The microprocessor installation tool might become worn after several uses. Make sure that the tool can hold the microprocessor securely if you are reusing an existing microprocessor installation tool. Do not return the tool with other parts that you are returning.



- If you are installing a second microprocessor, the option kit comes with a microprocessor installation tool that you must use when you install a microprocessor. The microprocessor installation tool comes with the replacement microprocessor installed on it and a cover over the microprocessor.
- If you are replacing a defective microprocessor, the CRU kit comes with one installation tool with the replacement microprocessor installed on it and a cover over the microprocessor, and one empty installation tool without a cover.
- If you are replacing a defective microprocessor, you must obtain the following items for use during the replacement procedure (see Chapter 5 “Parts listing, Types 7167 and 2590” on page 51):
  - Alcohol wipes
  - Thermal grease

**Note:** Be sure to use the installation tool that comes with your microprocessor installation tool assembly. The tools are similar in function and design, however Tool A has one setting for installing one size of microprocessor, and supports the following families of microprocessors: E5-26xx, E5-46xx. Installation Tool B has two settings for installing two different sizes of microprocessors. The settings that are marked on Tool B are “L” for smaller low core microprocessors, and “H” for larger high core microprocessors. Installation Tool B supports the following families of microprocessors: E5-26xx, E5-46xx, E5-26xx v2, E5-46xx v2.

Microprocessor Installation Tools A and B are shown in the following illustration.

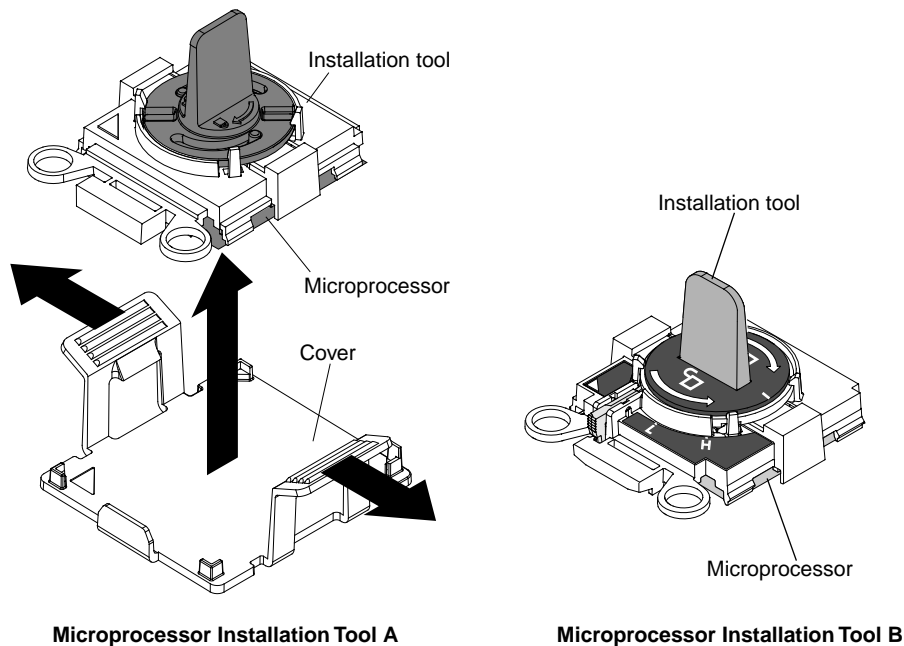

To remove a microprocessor and heat sink, complete the following steps.

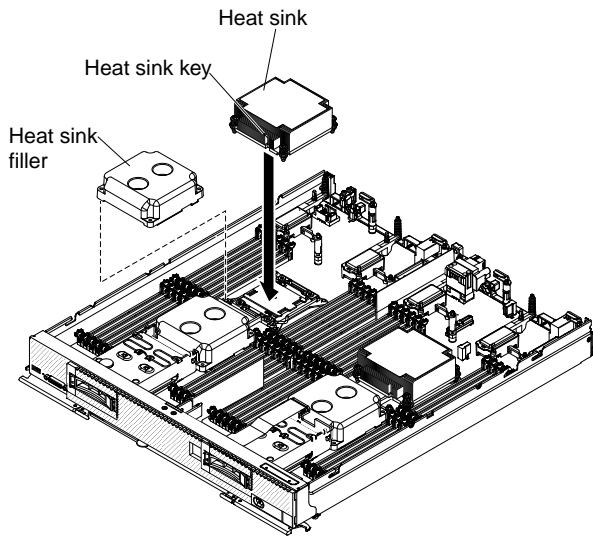

- Step 1. Remove the cover (see “Removing the compute node cover” on page 836).
- Step 2. Locate the microprocessor that is to be removed (see “System-board connectors” on page 18).
- Step 3. Remove the heat sink.

**Attention:** Do not touch the thermal material on the bottom of the heat sink. Touching the thermal material will contaminate it.

- a. Use a screwdriver to loosen the screw on one side of the heat sink to break the seal with the microprocessor.
- b. Use a screwdriver to loosen the screws on the heat sink, rotating each screw two full turns until each screw is loose.
- c. Gently pull the heat sink from the microprocessor.

**Attention:** Do not use any tools or sharp objects to lift the release levers on the microprocessor socket. Doing so might result in permanent damage to the system board.

- Step 4. Open the microprocessor socket release levers and retainer.

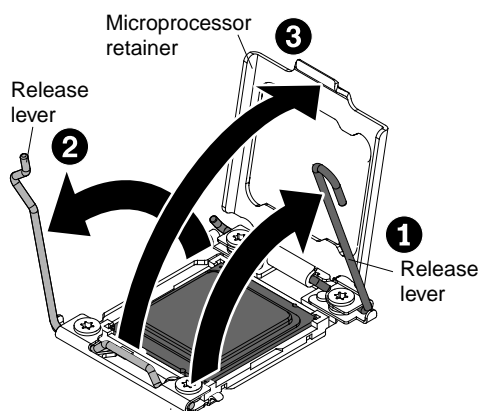

- a. Identify which release lever is labeled as the first release lever to open, and open it.
- b. Open the second release lever on the microprocessor socket.
- c. Open the microprocessor retainer.

**Attention:** Do not touch the connectors on the microprocessor and the microprocessor socket.

- Step 5. Remove the microprocessor from the socket.

- a. Select the empty installation tool and ensure that the handle is in the open position. If the installation tool handle is not in the open position, use the following instructions for your installation tool:
- If using Installation Tool A, twist the microprocessor installation tool handle counterclockwise to the open position.
  - If using Installation Tool B, 1) lift the interlock latch and hold it up while you 2) twist the microprocessor installation tool handle counterclockwise to the open position, and then release the interlock latch. The following illustration of the installation tool shows the location of the interlock latch and counterclockwise rotation of the handle before loading the microprocessor.

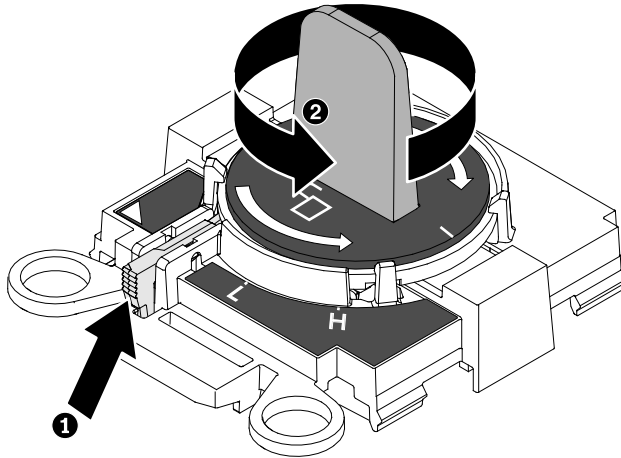

- b. Align the installation tool with the screws, as shown in the following graphic, and lower the installation tool on the microprocessor. The installation tool rests flush on the socket only when it is aligned correctly.

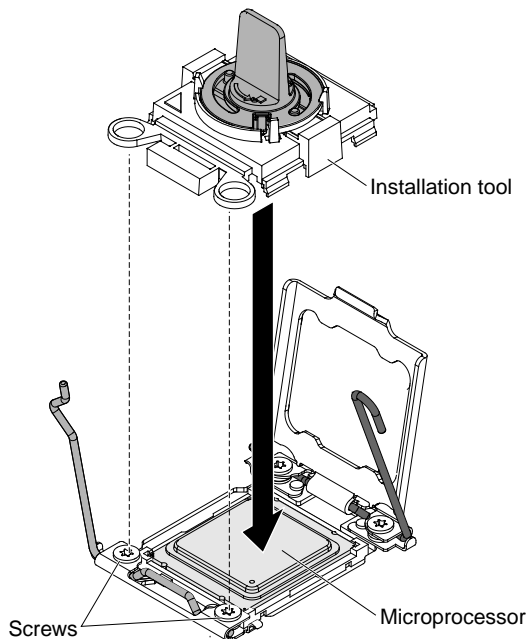

- c. Using the following instructions for your installation tool, remove the microprocessor.
- If using Installation Tool A, gently twist the handle clockwise to the closed position and lift the microprocessor out of the socket.

- If using Installation Tool B, gently twist the handle of the installation tool clockwise until it locks in the “H” or “L” position, depending on the size of microprocessor, and then lift the microprocessor out of the socket.

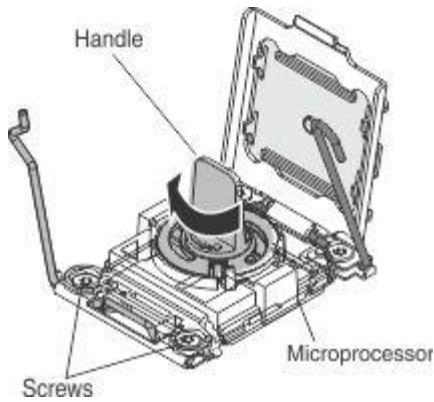

If you are instructed to return the microprocessor and heat sink, follow all packaging instructions, and use any packaging materials for shipping that are supplied to you.

## Installing a microprocessor and heat sink

Use this information to install a microprocessor and heat sink.

**Note:** This procedure should be performed only by trained service technicians.

The architecture of the Intel E5-46xx CPU and DMI switching of microprocessor sockets 1 and 2 allow for the processors to be populated as shown in the following figures.

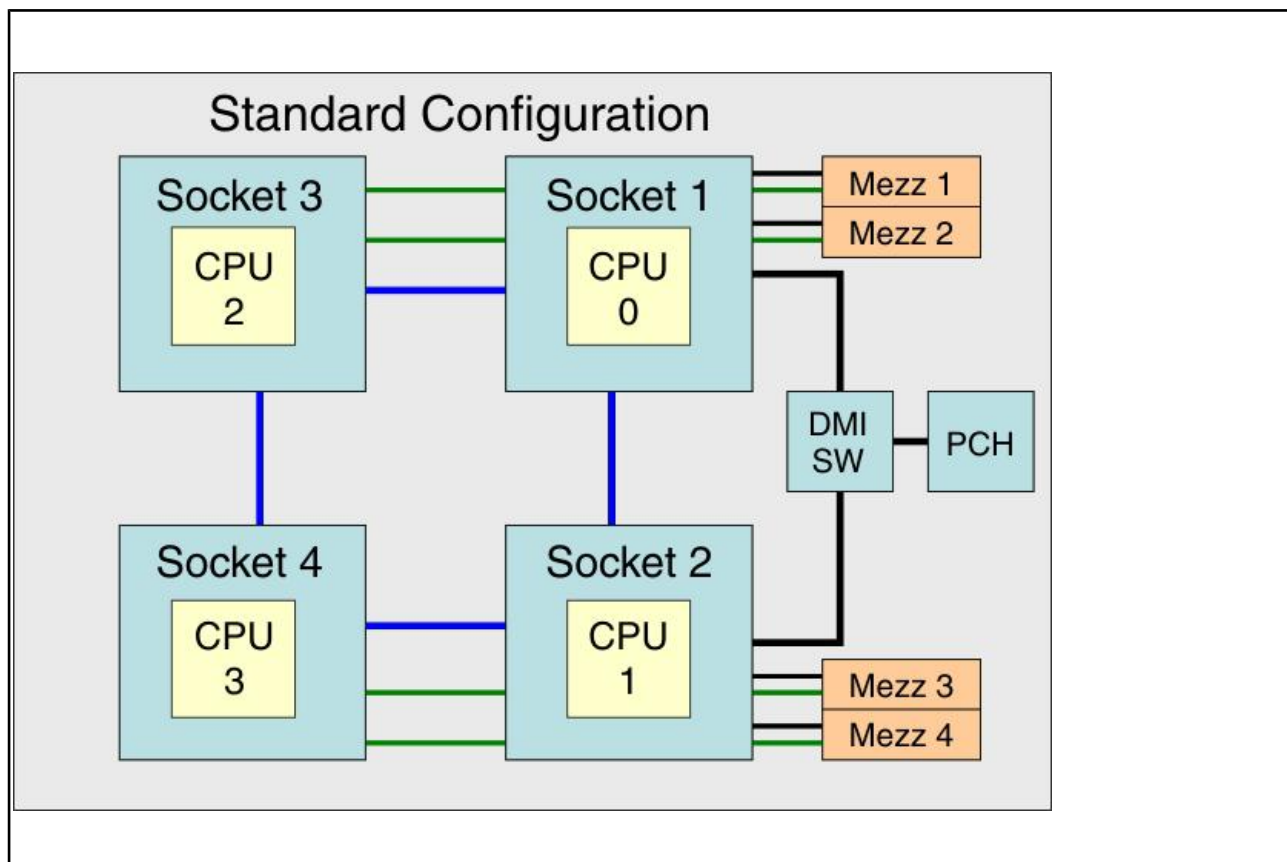

Table 15. Supported CPU installation combinations

| Number of microprocessors | Microprocessors socket 1 | Microprocessors socket 2 | Microprocessors socket 3 | Microprocessors socket 4 |
|---------------------------|--------------------------|--------------------------|--------------------------|--------------------------|
| 1                         | CPU0                     |                          |                          |                          |
| 2                         | CPU0                     | CPU1                     |                          |                          |
| 4                         | CPU0                     | CPU1                     | CPU2                     | CPU3                     |

**Notes:**

1. CPU0 is the boot strap processor.
2. If a bad processor in microprocessor socket 1 causes the processor installed in microprocessor socket 2 to become the boot strap processor and is subsequently replaced, the processor ordering reverts to the default CPU IDs for the new number of CPUs, because the FPGA would not hold the last CPU ID assignments and “add in” the replaced processor.
3. Three-processor configurations are not supported.
4. A microprocessor failure in a four-processor configuration will result in the system failing down to three functional microprocessors.

The supported microprocessor configurations are shown in the following illustrations.

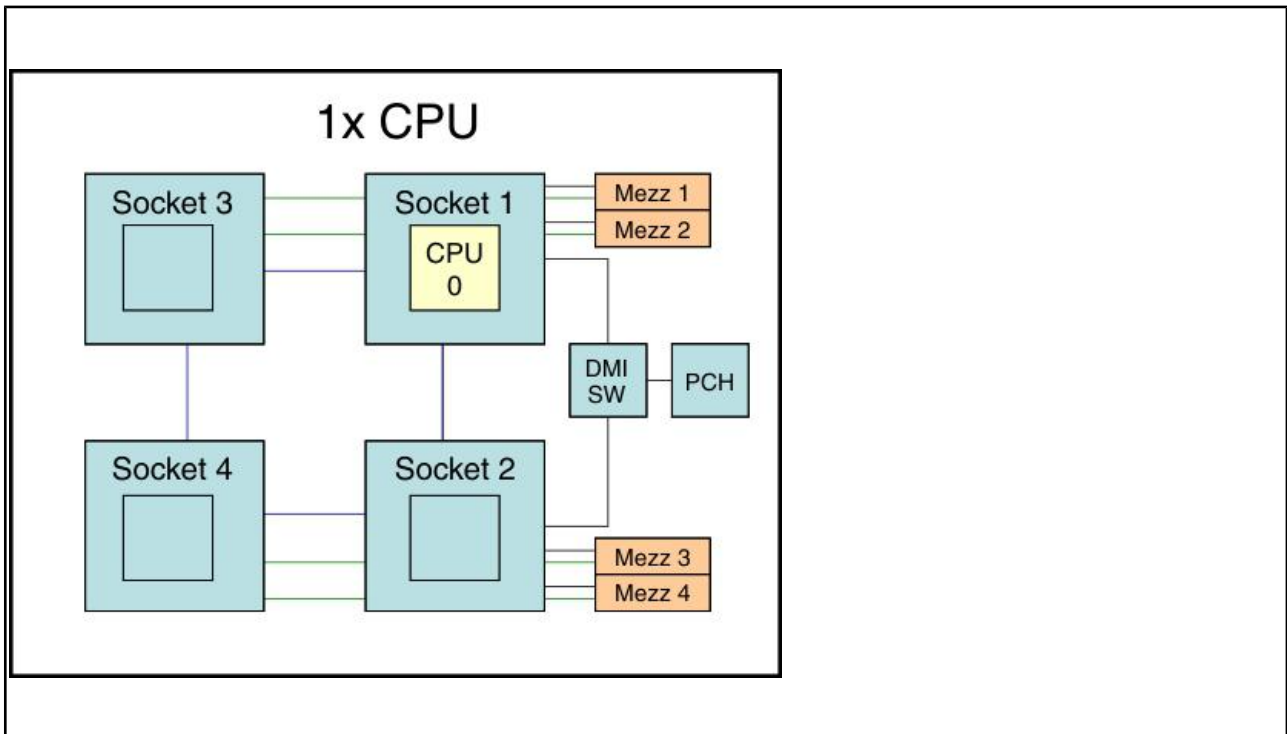

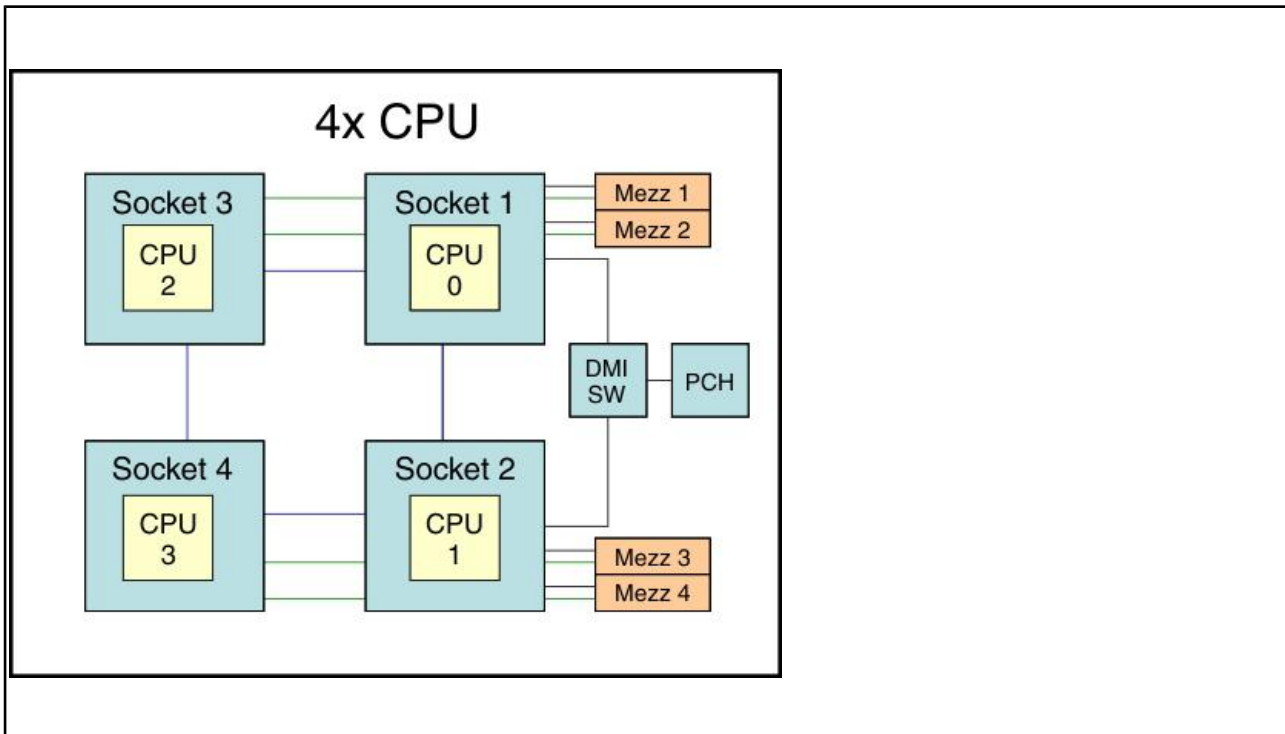
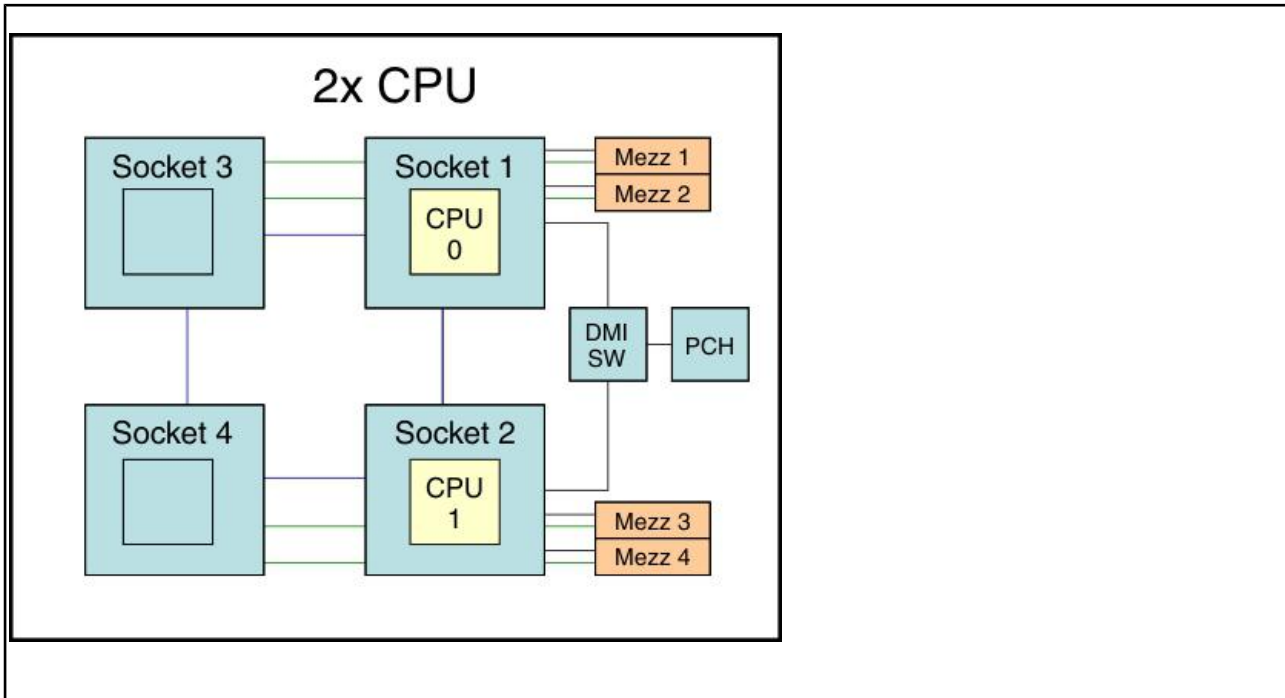

Before you install a microprocessor and heat sink, complete the following steps:

1. Read "Safety" on page iii and "Installation guidelines" on page 827.
2. If the compute node is installed in a Flex System chassis, remove it (see "Removing a compute node from a chassis" on page 828 for instructions).
3. Carefully lay the compute node on a flat, static-protective surface, orienting the compute node with the bezel pointing toward you.

The following notes describe the type of microprocessor that the compute node supports and other information that you must consider when you install a microprocessor:

- This component can be installed as an optional device or as a CRU. The installation procedure is the same for the optional device and the CRU.
- The optional microprocessors are limited by the capacity and capability of the compute node. Any microprocessors that you install must have the same specifications as the microprocessors that came with the compute node.
- A socket cover and heat-sink filler or a microprocessor and heat sink must always be installed on microprocessor sockets 1, 3, and 4. Microprocessor socket 2 will only have a socket cover when a microprocessor is not installed. If the compute node has only one microprocessor, it must be installed in microprocessor socket 1.
- If you are installing a second microprocessor, make sure that the microprocessors are identical.
- Before you install a new microprocessor, download and install the most current level of UEFI code (see “Updating firmware and device drivers” on page 23).
- When you install a second microprocessor, you might have to install additional memory or redistribute memory across the DIMM connectors. See “Installing a DIMM ” on page 840.
- The microprocessor installation tool might become worn after several uses. Make sure that the tool can hold the microprocessor securely if you are reusing an existing microprocessor installation tool. Do not return the tool with other parts that you are returning.
- If you are installing a second microprocessor, the microprocessor option kit comes with a microprocessor installation tool that you must use when you install a microprocessor. The microprocessor installation tool comes with the replacement microprocessor installed on it and a cover over the microprocessor.
- If you are replacing a defective microprocessor, the CRU kit comes with one installation tool with the replacement microprocessor installed on it and a cover over the microprocessor, and one empty installation tool without a cover.
- If you are replacing a defective microprocessor, you must obtain the following items for use during the replacement procedure (see Chapter 5 “Parts listing, Types 7167 and 2590” on page 51):
  - Alcohol wipes
  - Thermal grease

**Attention:**

1. Do not use any tools or sharp objects to lift the locking levers on the microprocessor socket. Doing so might result in permanent damage to the system board.
2. Do not touch the contacts in the microprocessor socket. Touching these contacts might result in permanent damage to the system board.

**Note:** Be sure to use the installation tool that comes with your microprocessor installation tool assembly. The tools are similar in function and design, however Tool A has one setting for installing one size of microprocessor, and supports the following families of microprocessors: E5-26xx, E5-46xx. Installation Tool B has two settings for installing two different sizes of microprocessors. The settings that are marked on Tool B are “L” for smaller low core microprocessors, and “H” for larger high core microprocessors. Installation Tool B supports the following families of microprocessors: E5-26xx, E5-46xx, E5-26xx v2, E5-46xx v2.

Microprocessor Installation Tools A and B are shown in the following illustration.

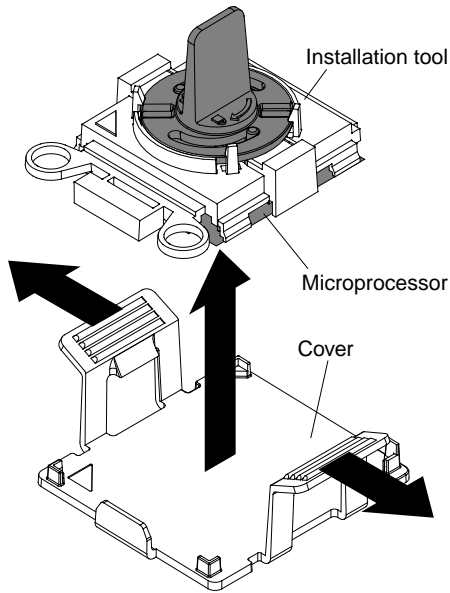

**Microprocessor Installation Tool A**

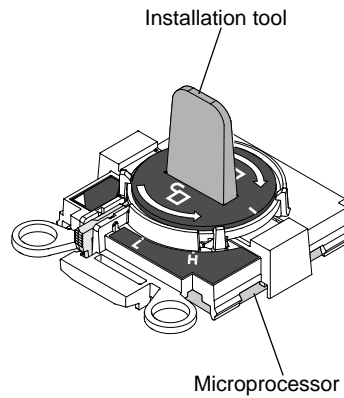

**Microprocessor Installation Tool B**

To install a microprocessor and heat sink, complete the following steps.

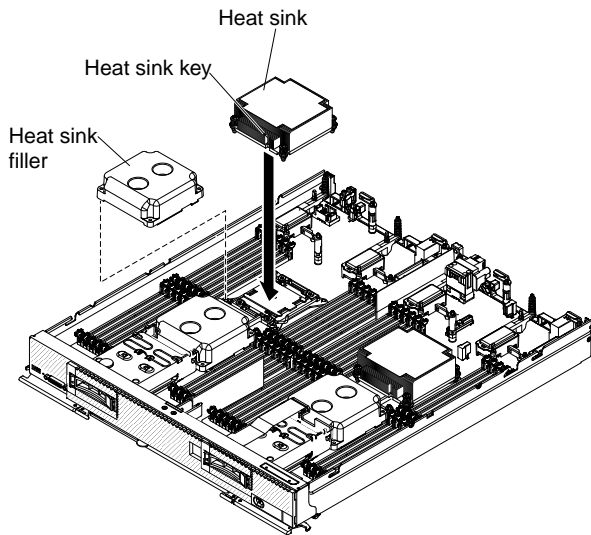

- Step 1. Remove the cover (see “Removing the compute node cover” on page 836).
- Step 2. If you are not installing a new microprocessor and a new heat sink, remove the thermal grease from the heat sink and microprocessor; then, apply new thermal grease before installation (see “Thermal grease” on page 888).
- Step 3. Remove the heat-sink filler, if one is present.
- Step 4. Open the microprocessor socket release levers and retainer.



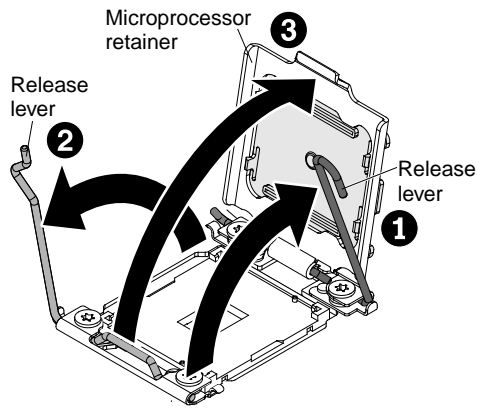

- a. Identify which release lever is labeled as the first release lever to open and open it.
- b. Open the second release lever on the microprocessor socket.
- c. Open the microprocessor retainer.

Step 5. Install the microprocessor in the microprocessor socket.

- a. Open the packaging that contains the new microprocessor installation tool assembly and carefully remove the installation tool assembly from the package.

**Note:** Do not touch the microprocessor contacts. Contaminants on the microprocessor contacts, such as oil from your skin, can cause connection failures between the contacts and the socket.

- b. Remove the microprocessor protective cover if one is present.

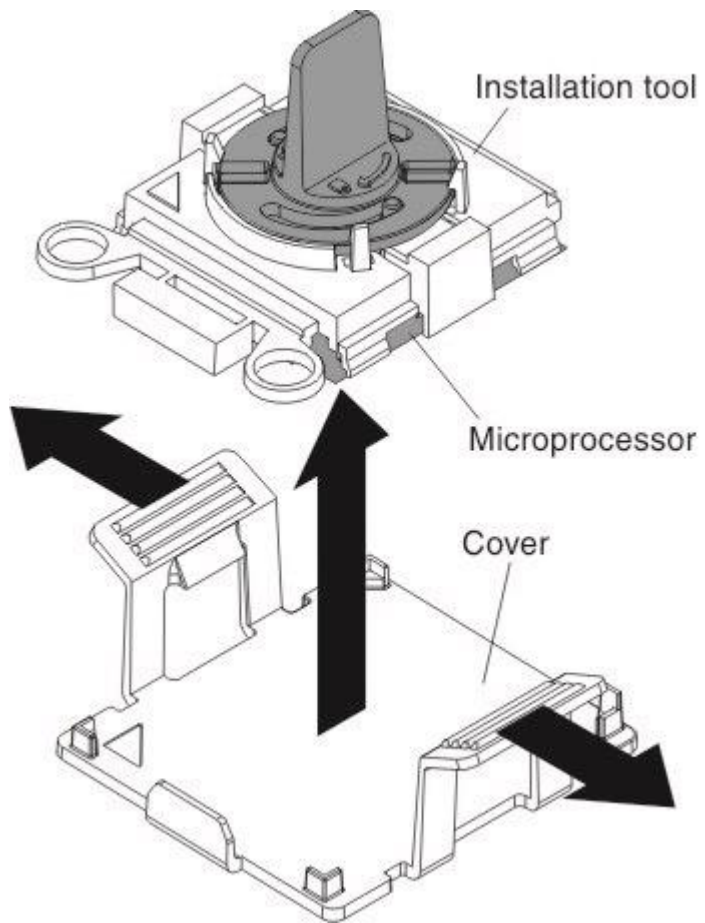

- c. Align the installation tool with the microprocessor socket. The installation tool rests flush on the socket only if it is properly aligned.

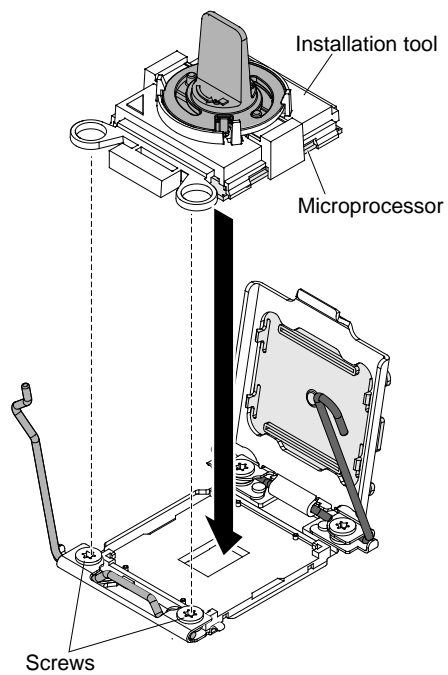

- d. Install the microprocessor using the following instructions for your installation tool.

- If using Installation Tool A, twist the handle on the microprocessor tool assembly counterclockwise to the open position to insert the microprocessor into the socket, and lift the installation tool out of the socket.
- If using Installation Tool B, twist the handle of the installation tool assembly counterclockwise until the microprocessor is inserted into the socket, and lift the installation tool out of the socket. The following illustration shows the tool handle in the open position.

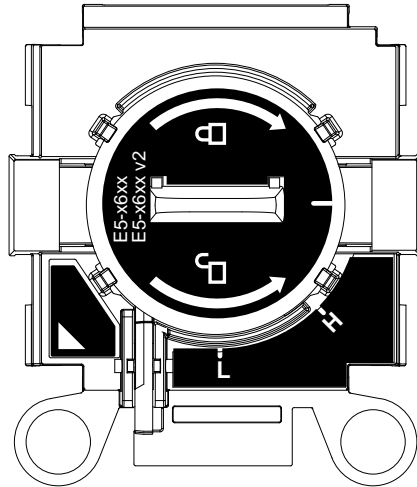

**Attention:**

- Do not press the microprocessor into the socket.
- Make sure that the microprocessor is aligned correctly in the socket before you try to close the microprocessor retainer.
- Do not touch the thermal grease on the bottom of the heat sink or on top of the microprocessor. Touching the thermal grease will contaminate it.

Step 6. Close the microprocessor socket release retainer and levers.

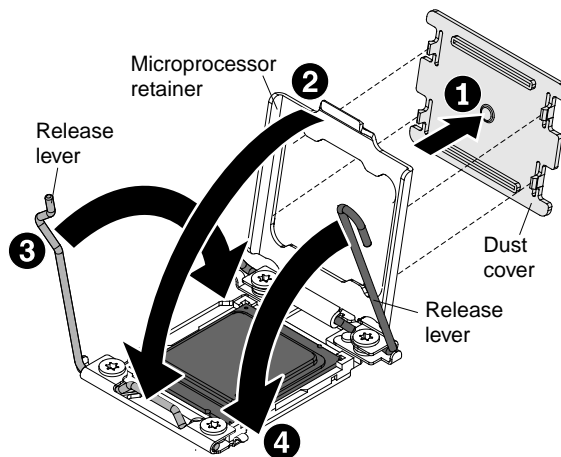

- a. Close the microprocessor retainer on the microprocessor socket.
- b. Identify which release lever is labeled as the first release lever to close, and close it.
- c. Close the second release lever on the microprocessor socket.
- d. If a socket cover is installed over the microprocessor retainer, it is released as you close the retainer. Remove the socket cover from the compute node and store it in a safe place.

**Attention:**

- If you are installing a new heat sink, do not set down the heat sink after you remove the plastic cover.
- Do not touch the thermal material on the bottom of the heat sink. Touching the thermal material will contaminate it.

- Step 7. If you are installing a new heat sink, remove the plastic protective cover from the bottom of the heat sink. If you are reinstalling a heat sink that you previously removed from the compute node, make sure that the thermal material is still on the bottom of the heat sink and on the top of the microprocessor.
- a. Position the heat sink over the microprocessor. The heat sink is keyed to assist with proper alignment.
  - b. Align and place the heat sink on top of the microprocessor in the retention bracket, thermal material side down.
  - c. Press firmly on the heat sink.
  - d. Align the screws on the heat sink with the holes on the heat-sink retention module.
  - e. Press firmly on the captive screws and tighten them with a screwdriver, alternating among the screws until they are tight. If possible, each screw should be rotated two full rotations at a time. Repeat until the screws are tight. Do not overtighten the screws by using excessive force. If you are using a torque wrench, tighten the screws to 0.9 Newton-meters (Nm) to 1.13 Nm (8 inch-pounds to 10 inch-pounds).

After you install a microprocessor and heat sink, complete the following steps:

1. Install the cover (see “Installing the compute node cover” on page 838).
2. Install the compute node in a Flex System chassis (see “Installing a compute node in a chassis” on page 829 for instructions).

## Thermal grease

Use this information to determine the guidelines for using thermal grease on a heat sink and microprocessor.

**Note:** This procedure should be performed only by trained service technicians.

The thermal grease must be replaced whenever the heat sink has been removed from the top of the microprocessor and is going to be reused or when debris is found in the grease.

To replace damaged or contaminated thermal grease on the microprocessor and heat sink, complete the following steps:

- Step 1. Place the heat-sink assembly on a clean work surface.
- Step 2. Remove the cleaning pad from its package and unfold it completely.
- Step 3. Use the cleaning pad to wipe the thermal grease from the bottom of the heat sink.

**Note:** Make sure that all of the thermal grease is removed.

- Step 4. Use a clean area of the cleaning pad to wipe the thermal grease from the microprocessor; then, dispose of the cleaning pad after all of the thermal grease is removed.

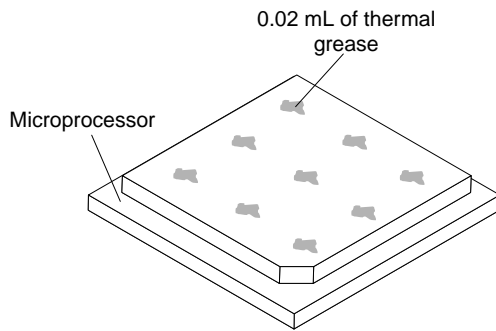

Step 5. Use the thermal-grease syringe to place nine uniformly spaced dots of 0.02 mL each on the top of the microprocessor.

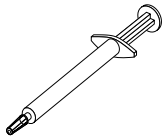

**Note:** 0.01mL is one tick mark on the syringe. If the grease is properly applied, approximately half (0.22 mL) of the grease will remain in the syringe.

Step 6. Continue with the microprocessor installation instructions in “Installing a microprocessor and heat sink” on page 880.

## Removing a microprocessor-retention assembly

Use this information to remove a microprocessor-retention assembly.

**Note:** This procedure should be performed only by trained service technicians.

Before you remove the microprocessor-retention assembly, complete the following steps:

1. Read “Safety” on page iii and “Installation guidelines” on page 827.
2. If the compute node is installed in a Flex System chassis, remove it (see “Removing a compute node from a chassis” on page 828 for instructions).
3. Carefully lay the compute node on a flat, static-protective surface, orienting the compute node with the bezel pointing toward you.

To remove a microprocessor-retention assembly, complete the following steps.

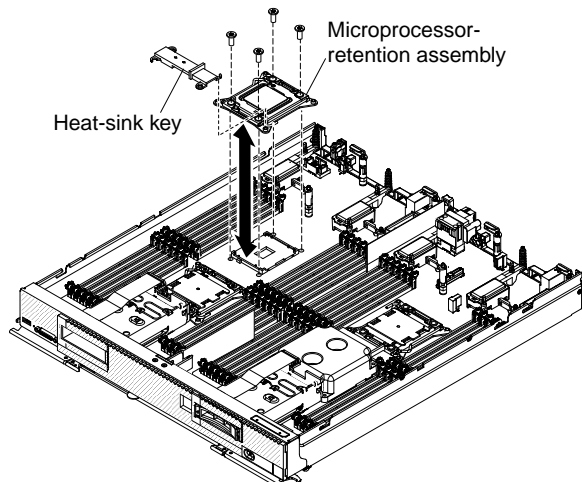

- Step 1. Remove the cover (see “Removing the compute node cover” on page 836).
- Step 2. Locate the microprocessor socket on the system board.
- Step 3. If a microprocessor and heat sink are installed, remove them (see “Removing a microprocessor and heat sink” on page 876).
- Step 4. Remove the heat-sink key from the microprocessor-retention assemblies and store it in a safe place.
- Step 5. Make sure that the microprocessor socket release levers are in the open position.
- Step 6. Using a T20 Torx screwdriver, remove the four screws that secure the microprocessor-retention assembly.

**Attention:**

1. Do not allow the microprocessor-retention assembly to touch the microprocessor socket. Doing so might result in permanent damage to the system board.
2. Do not touch the contacts in the microprocessor socket. Touching these contacts might result in permanent damage to the system board.

- Step 7. Lift the microprocessor-retention assembly from the system board.

If you are instructed to return the microprocessor-retention assembly, follow all packaging instructions, and use any packaging materials for shipping that are supplied to you.

## Installing a microprocessor-retention assembly

Use this information to install a microprocessor-retention assembly.

**Note:** This procedure should be performed only by trained service technicians.

Before you install a microprocessor-retention assembly, complete the following steps:

1. Read “Safety” on page iii and “Installation guidelines” on page 827.
2. If the compute node is installed in a Flex System chassis, remove it (see “Removing a compute node from a chassis” on page 828 for instructions).
3. Carefully lay the compute node on a flat, static-protective surface, orienting the compute node with the bezel pointing toward you.

To install a microprocessor-retention assembly, complete the following steps.

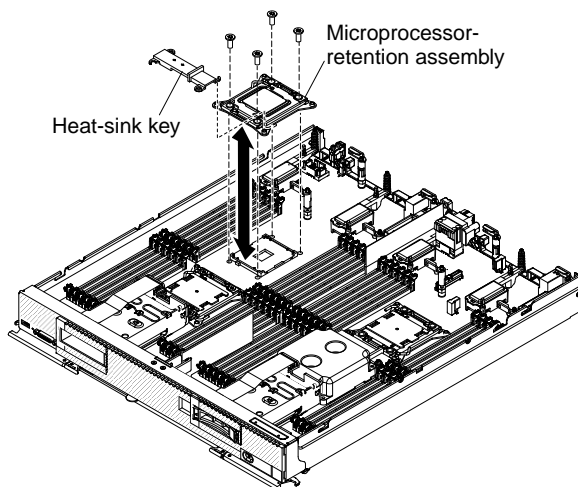

- Step 1. Remove the cover (see “Removing the compute node cover” on page 836).

Step 2. Make sure that the microprocessor socket release levers are in the open position.

Step 3. Align the microprocessor-retention assembly on the system board.

**Attention:**

1. Do not allow the microprocessor-retention assembly to touch the microprocessor socket. Doing so might result in permanent damage to the system board.
2. Do not touch the contacts in the microprocessor socket. Touching these contacts might result in permanent damage to the system board.

Step 4. Using a T20 Torx screwdriver, install the four screws to secure the microprocessor-retention assembly.

Step 5. Install the heat-sink key on the microprocessor retention assemblies.

Step 6. If necessary, install the microprocessor and heat sink (see “Installing a microprocessor and heat sink” on page 880).

After you install the microprocessor-retention assembly, complete the following steps:

1. Install the cover onto the compute node (see “Installing the compute node cover” on page 838 for instructions).
2. Install the compute node into the chassis (see “Installing a compute node in a chassis” on page 829 for instructions).





---

## Appendix A. Getting help and technical assistance

If you need help, service, or technical assistance or just want more information about Lenovo products, you will find a wide variety of sources available from Lenovo to assist you.

Use this information to obtain additional information about Lenovo and Lenovo products, and determine what to do if you experience a problem with your Lenovo system or optional device.

**Note:** This section includes references to IBM web sites and information about obtaining service. IBM is Lenovo's preferred service provider for the System x, Flex System, and NeXtScale System products.

---

### Before you call

Before you call, make sure that you have taken these steps to try to solve the problem yourself.

If you believe that you require warranty service for your Lenovo product, the service technicians will be able to assist you more efficiently if you prepare before you call.

- Check all cables to make sure that they are connected.
- Check the power switches to make sure that the system and any optional devices are turned on.
- Check for updated software, firmware, and operating-system device drivers for your Lenovo product. The Lenovo Warranty terms and conditions state that you, the owner of the Lenovo product, are responsible for maintaining and updating all software and firmware for the product (unless it is covered by an additional maintenance contract). Your service technician will request that you upgrade your software and firmware if the problem has a documented solution within a software upgrade.
- If you have installed new hardware or software in your environment, check <http://www.lenovo.com/serverproven/> to make sure that the hardware and software is supported by your product.
- Go to <http://www.lenovo.com/support> to check for information to help you solve the problem.
- Gather the following information to provide to the service technician. This data will help the service technician quickly provide a solution to your problem and ensure that you receive the level of service for which you might have contracted.
  - Hardware and Software Maintenance agreement contract numbers, if applicable
  - Machine type number (Lenovo 4-digit machine identifier)
  - Model number
  - Serial number
  - Current system UEFI and firmware levels
  - Other pertinent information such as error messages and logs
- Go to [http://www.ibm.com/support/entry/portal/Open\\_service\\_request](http://www.ibm.com/support/entry/portal/Open_service_request) to submit an Electronic Service Request. Submitting an Electronic Service Request will start the process of determining a solution to your problem by making the pertinent information available to the service technicians. The IBM service technicians can start working on your solution as soon as you have completed and submitted an Electronic Service Request.

You can solve many problems without outside assistance by following the troubleshooting procedures that Lenovo provides in the online help or in the Lenovo product documentation. The Lenovo product documentation also describes the diagnostic tests that you can perform. The documentation for most systems, operating systems, and programs contains troubleshooting procedures and explanations of error messages and error codes. If you suspect a software problem, see the documentation for the operating system or program.

---

## Using the documentation

Information about your Lenovo system and preinstalled software, if any, or optional device is available in the product documentation. That documentation can include printed documents, online documents, readme files, and help files.

See the troubleshooting information in your system documentation for instructions for using the diagnostic programs. The troubleshooting information or the diagnostic programs might tell you that you need additional or updated device drivers or other software. Lenovo maintains pages on the World Wide Web where you can get the latest technical information and download device drivers and updates. To access these pages, go to <http://www.lenovo.com/support>.

---

## Getting help and information from the World Wide Web

Up-to-date information about Lenovo products and support is available on the World Wide Web.

On the World Wide Web, up-to-date information about Lenovo systems, optional devices, services, and support is available at <http://www.lenovo.com/support>. The most current version of the product documentation is available in the following product-specific Information Centers:

**Flex System products:**<http://pic.dhe.ibm.com/infocenter/flexsys/information/index.jsp>

**System x products:**<http://shop.lenovo.com/us/en/systems/>

**NeXtScale System products:**<http://pic.dhe.ibm.com/infocenter/nxtscale/documentation/index.jsp>

---

## How to send DSA data

You can use the Enhanced Customer Data Repository to send diagnostic data to IBM.

Before you send diagnostic data to IBM, read the terms of use at <http://www.ibm.com/de/support/ecurep/terms.html>.

You can use any of the following methods to send diagnostic data:

- **Standard upload:** [http://www.ibm.com/de/support/ecurep/send\\_http.html](http://www.ibm.com/de/support/ecurep/send_http.html)
- **Standard upload with the system serial number:** [http://www.ecurep.ibm.com/app/upload\\_hw](http://www.ecurep.ibm.com/app/upload_hw)
- **Secure upload:** [http://www.ibm.com/de/support/ecurep/send\\_http.html#secure](http://www.ibm.com/de/support/ecurep/send_http.html#secure)
- **Secure upload with the system serial number:** [https://www.ecurep.ibm.com/app/upload\\_hw](https://www.ecurep.ibm.com/app/upload_hw)

---

## Creating a personalized support web page

You can create a personalized support web page by identifying Lenovo products that are of interest to you.

To create a personalized support web page, go to <http://www.ibm.com/support/mynotifications>. From this personalized page, you can subscribe to weekly email notifications about new technical documents, search for information and downloads, and access various administrative services.

---

## Software service and support

Through IBM Support Line, you can get telephone assistance, for a fee, with usage, configuration, and software problems with your Lenovo products.

For more information about Support Line and other IBM services, see <http://www.ibm.com/services> or see <http://www.ibm.com/planetwide> for support telephone numbers. In the U.S. and Canada, call 1-800-IBM-SERV (1-800-426-7378).

---

## Hardware service and support

IBM is Lenovo's preferred service provider for the System x, Flex System and NeXtScale System products.

You can receive hardware service through your Lenovo reseller or from IBM. To locate a reseller authorized by Lenovo to provide warranty service, go to <http://www.ibm.com/partnerworld> and click **Business Partner Locator**. For IBM support telephone numbers, see <http://www.ibm.com/planetwide>. In the U.S. and Canada, call 1-800-IBM-SERV (1-800-426-7378).

In the U.S. and Canada, hardware service and support is available 24 hours a day, 7 days a week. In the U.K., these services are available Monday through Friday, from 9 a.m. to 6 p.m.

---

## Taiwan product service

Use this information to contact product service for Taiwan.

委製商/進口商名稱: 台灣聯想環球科技股份有限公司  
進口商地址: 台北市南港區三重路 66 號 8 樓  
進口商電話: 0800-000-702



---

## Appendix B. Notices

Lenovo may not offer the products, services, or features discussed in this document in all countries. Consult your local Lenovo representative for information on the products and services currently available in your area.

Any reference to a Lenovo product, program, or service is not intended to state or imply that only that Lenovo product, program, or service may be used. Any functionally equivalent product, program, or service that does not infringe any Lenovo intellectual property right may be used instead. However, it is the user's responsibility to evaluate and verify the operation of any other product, program, or service.

Lenovo may have patents or pending patent applications covering subject matter described in this document. The furnishing of this document is not an offer and does not provide a license under any patents or patent applications. You can send inquiries in writing to the following:

*Lenovo (United States), Inc.  
1009 Think Place  
Morrisville, NC 27560  
U.S.A.  
Attention: Lenovo VP of Intellectual Property*

LENOVO PROVIDES THIS PUBLICATION "AS IS" WITHOUT WARRANTY OF ANY KIND, EITHER EXPRESS OR IMPLIED, INCLUDING, BUT NOT LIMITED TO, THE IMPLIED WARRANTIES OF NON-INFRINGEMENT, MERCHANTABILITY OR FITNESS FOR A PARTICULAR PURPOSE. Some jurisdictions do not allow disclaimer of express or implied warranties in certain transactions, therefore, this statement may not apply to you.

This information could include technical inaccuracies or typographical errors. Changes are periodically made to the information herein; these changes will be incorporated in new editions of the publication. Lenovo may make improvements and/or changes in the product(s) and/or the program(s) described in this publication at any time without notice.

The products described in this document are not intended for use in implantation or other life support applications where malfunction may result in injury or death to persons. The information contained in this document does not affect or change Lenovo product specifications or warranties. Nothing in this document shall operate as an express or implied license or indemnity under the intellectual property rights of Lenovo or third parties. All information contained in this document was obtained in specific environments and is presented as an illustration. The result obtained in other operating environments may vary.

Lenovo may use or distribute any of the information you supply in any way it believes appropriate without incurring any obligation to you.

Any references in this publication to non-Lenovo Web sites are provided for convenience only and do not in any manner serve as an endorsement of those Web sites. The materials at those Web sites are not part of the materials for this Lenovo product, and use of those Web sites is at your own risk.

Any performance data contained herein was determined in a controlled environment. Therefore, the result obtained in other operating environments may vary significantly. Some measurements may have been made on development-level systems and there is no guarantee that these measurements will be the same on generally available systems. Furthermore, some measurements may have been estimated through extrapolation. Actual results may vary. Users of this document should verify the applicable data for their specific environment.

---

## Trademarks

Lenovo, the Lenovo logo, Flex System, System x, NeXtScale System, and x Architecture are trademarks of Lenovo in the United States, other countries, or both.

Intel and Intel Xeon are trademarks of Intel Corporation in the United States, other countries, or both.

Internet Explorer, Microsoft, and Windows are trademarks of the Microsoft group of companies.

Linux is a registered trademark of Linus Torvalds.

Other company, product, or service names may be trademarks or service marks of others.

---

## Important notes

Processor speed indicates the internal clock speed of the microprocessor; other factors also affect application performance.

CD or DVD drive speed is the variable read rate. Actual speeds vary and are often less than the possible maximum.

When referring to processor storage, real and virtual storage, or channel volume, KB stands for 1 024 bytes, MB stands for 1 048 576 bytes, and GB stands for 1 073 741 824 bytes.

When referring to hard disk drive capacity or communications volume, MB stands for 1 000 000 bytes, and GB stands for 1 000 000 000 bytes. Total user-accessible capacity can vary depending on operating environments.

Maximum internal hard disk drive capacities assume the replacement of any standard hard disk drives and population of all hard-disk-drive bays with the largest currently supported drives that are available from Lenovo.

Maximum memory might require replacement of the standard memory with an optional memory module.

Each solid-state memory cell has an intrinsic, finite number of write cycles that the cell can incur. Therefore, a solid-state device has a maximum number of write cycles that it can be subjected to, expressed as total bytes written (TBW). A device that has exceeded this limit might fail to respond to system-generated commands or might be incapable of being written to. Lenovo is not responsible for replacement of a device that has exceeded its maximum guaranteed number of program/erase cycles, as documented in the Official Published Specifications for the device.

Lenovo makes no representations or warranties with respect to non-Lenovo products. Support (if any) for the non-Lenovo products is provided by the third party, not Lenovo.

Some software might differ from its retail version (if available) and might not include user manuals or all program functionality.

---

## Recycling information

Lenovo encourages owners of information technology (IT) equipment to responsibly recycle their equipment when it is no longer needed. Lenovo offers a variety of programs and services to assist equipment owners in recycling their IT products. For information on recycling Lenovo products, go to: <http://www.lenovo.com/recycling>.



US & Canada Only



US & Canada Only

## Particulate contamination

**Attention:** Airborne particulates (including metal flakes or particles) and reactive gases acting alone or in combination with other environmental factors such as humidity or temperature might pose a risk to the device that is described in this document.

Risks that are posed by the presence of excessive particulate levels or concentrations of harmful gases include damage that might cause the device to malfunction or cease functioning altogether. This specification sets forth limits for particulates and gases that are intended to avoid such damage. The limits must not be viewed or used as definitive limits, because numerous other factors, such as temperature or moisture content of the air, can influence the impact of particulates or environmental corrosives and gaseous contaminant transfer. In the absence of specific limits that are set forth in this document, you must implement practices that maintain particulate and gas levels that are consistent with the protection of human health and safety. If Lenovo determines that the levels of particulates or gases in your environment have caused damage to the device, Lenovo may condition provision of repair or replacement of devices or parts on implementation of appropriate remedial measures to mitigate such environmental contamination. Implementation of such remedial measures is a customer responsibility.

Table 16. Limits for particulates and gases

| Contaminant   | Limits  |
|---|---|
| Particulate   | <ul style="list-style-type: none"> <li>The room air must be continuously filtered with 40% atmospheric dust spot efficiency (MERV 9) according to ASHRAE Standard 52.2<sup>1</sup>.</li> <li>Air that enters a data center must be filtered to 99.97% efficiency or greater, using high-efficiency particulate air (HEPA) filters that meet MIL-STD-282.</li> <li>The deliquescent relative humidity of the particulate contamination must be more than 60%<sup>2</sup>.</li> <li>The room must be free of conductive contamination such as zinc whiskers.</li> </ul> |
| Gaseous   | <ul style="list-style-type: none"> <li>Copper: Class G1 as per ANSI/ISA 71.04-1985<sup>3</sup></li> <li>Silver: Corrosion rate of less than 300 Å in 30 days</li> </ul>   |
| <p><sup>1</sup> ASHRAE 52.2-2008 - <i>Method of Testing General Ventilation Air-Cleaning Devices for Removal Efficiency by Particle Size</i>. Atlanta: American Society of Heating, Refrigerating and Air-Conditioning Engineers, Inc.</p> <p><sup>2</sup> The deliquescent relative humidity of particulate contamination is the relative humidity at which the dust absorbs enough water to become wet and promote ionic conduction.</p> <p><sup>3</sup> ANSI/ISA-71.04-1985. <i>Environmental conditions for process measurement and control systems: Airborne contaminants</i>. Instrument Society of America, Research Triangle Park, North Carolina, U.S.A.</p> |   |

## Telecommunication regulatory statement

This product may not be certified in your country for connection by any means whatsoever to interfaces of public telecommunications networks. Further certification may be required by law prior to making any such connection. Contact a Lenovo representative or reseller for any questions.

---

## Electronic emission notices

When you attach a monitor to the equipment, you must use the designated monitor cable and any interference suppression devices that are supplied with the monitor.

### Federal Communications Commission (FCC) statement

**Note:** This equipment has been tested and found to comply with the limits for a Class A digital device, pursuant to Part 15 of the FCC Rules. These limits are designed to provide reasonable protection against harmful interference when the equipment is operated in a commercial environment. This equipment generates, uses, and can radiate radio frequency energy and, if not installed and used in accordance with the instruction manual, may cause harmful interference to radio communications. Operation of this equipment in a residential area is likely to cause harmful interference, in which case the user will be required to correct the interference at his own expense.

Properly shielded and grounded cables and connectors must be used in order to meet FCC emission limits. Lenovo is not responsible for any radio or television interference caused by using other than recommended cables and connectors or by unauthorized changes or modifications to this equipment. Unauthorized changes or modifications could void the user's authority to operate the equipment.

This device complies with Part 15 of the FCC Rules. Operation is subject to the following two conditions: (1) this device may not cause harmful interference, and (2) this device must accept any interference received, including interference that might cause undesired operation.

### Industry Canada Class A emission compliance statement

This Class A digital apparatus complies with Canadian ICES-003.

### Avis de conformité à la réglementation d'Industrie Canada

Cet appareil numérique de la classe A est conforme à la norme NMB-003 du Canada.

### Australia and New Zealand Class A statement

**Attention:** This is a Class A product. In a domestic environment this product may cause radio interference in which case the user may be required to take adequate measures.

### European Union EMC Directive conformance statement

This product is in conformity with the protection requirements of EU Council Directive 2014/30/EU on the approximation of the laws of the Member States relating to electromagnetic compatibility. Lenovo cannot accept responsibility for any failure to satisfy the protection requirements resulting from a non-recommended modification of the product, including the installation of option cards from other manufacturers.

This product has been tested and found to comply with the limits for Class A equipment according to European Standards harmonized in the Directives in compliance. The limits for Class A equipment were derived for commercial and industrial environments to provide reasonable protection against interference with licensed communication equipment.

Lenovo, Einsteinova 21, 851 01 Bratislava, Slovakia



**Warning:** This is a Class A product. In a domestic environment this product may cause radio interference in which case the user may be required to take adequate measures.



## Germany Class A statement

### **Deutschsprachiger EU Hinweis: Hinweis für Geräte der Klasse A EU-Richtlinie zur Elektromagnetischen Verträglichkeit**

**Deutschsprachiger EU Hinweis: Hinweis für Geräte der Klasse A EU-Richtlinie zur Elektromagnetischen Verträglichkeit** Dieses Produkt entspricht den Schutzanforderungen der EU-Richtlinie 2014/30/EU zur Angleichung der Rechtsvorschriften über die elektromagnetische Verträglichkeit in den EU-Mitgliedsstaaten und hält die Grenzwerte der Klasse A der Norm gemäß Richtlinie.

Um dieses sicherzustellen, sind die Geräte wie in den Handbüchern beschrieben zu installieren und zu betreiben. Des Weiteren dürfen auch nur von der Lenovo empfohlene Kabel angeschlossen werden. Lenovo übernimmt keine Verantwortung für die Einhaltung der Schutzanforderungen, wenn das Produkt ohne Zustimmung der Lenovo verändert bzw. wenn Erweiterungskomponenten von Fremdherstellern ohne Empfehlung der Lenovo gesteckt/eingebaut werden.

### **Deutschland:**

**Einhaltung des Gesetzes über die elektromagnetische Verträglichkeit von Betriebsmitteln** Dieses Produkt entspricht dem „Gesetz über die elektromagnetische Verträglichkeit von Betriebsmitteln“ EMVG (früher „Gesetz über die elektromagnetische Verträglichkeit von Geräten“). Dies ist die Umsetzung der EU-Richtlinie 2014/30/EU in der Bundesrepublik Deutschland.

**Zulassungsbescheinigung laut dem Deutschen Gesetz über die elektromagnetische Verträglichkeit von Betriebsmitteln, EMVG vom 20. Juli 2007 (früher Gesetz über die elektromagnetische Verträglichkeit von Geräten), bzw. der EMV EU Richtlinie 2014/30/EU, für Geräte der Klasse A.**

Dieses Gerät ist berechtigt, in Übereinstimmung mit dem Deutschen EMVG das EG-Konformitätszeichen - CE - zu führen. Verantwortlich für die Konformitätserklärung nach Paragraph 5 des EMVG ist die Lenovo (Deutschland) GmbH, Meitnerstr. 9, D-70563 Stuttgart.

Informationen in Hinsicht EMVG Paragraph 4 Abs. (1) 4: **Das Gerät erfüllt die Schutzanforderungen nach EN 55024 und EN 55032 Klasse A.**

Nach der EN 55032: „Dies ist eine Einrichtung der Klasse A. Diese Einrichtung kann im Wohnbereich Funkstörungen verursachen; in diesem Fall kann vom Betreiber verlangt werden, angemessene Maßnahmen durchzuführen und dafür aufzukommen.“

Nach dem EMVG: „Geräte dürfen an Orten, für die sie nicht ausreichend entstört sind, nur mit besonderer Genehmigung des Bundesministers für Post und Telekommunikation oder des Bundesamtes für Post und Telekommunikation betrieben werden. Die Genehmigung wird erteilt, wenn keine elektromagnetischen Störungen zu erwarten sind.“ (Auszug aus dem EMVG, Paragraph 3, Abs. 4). Dieses Genehmigungsverfahren ist nach Paragraph 9 EMVG in Verbindung mit der entsprechenden Kostenverordnung (Amtsblatt 14/93) kostenpflichtig.

Anmerkung: Um die Einhaltung des EMVG sicherzustellen sind die Geräte, wie in den Handbüchern angegeben, zu installieren und zu betreiben.

## Japanese electromagnetic compatibility statements

### Japan VCCI Class A statement

この装置は、クラスA情報技術装置です。この装置を家庭環境で使用すると電波障害を引き起こすことがあります。この場合には使用者が適切な対策を講ずるよう要求されることがあります。 V C C I - A

## Korea Communications Commission (KCC) statement

이 기기는 업무용(A급)으로 전자파적합기기로서 판매자 또는 사용자는 이 점을 주의하시기 바라며, 가정외의 지역에서 사용하는 것을 목적으로 합니다.

This is electromagnetic wave compatibility equipment for business (Type A). Sellers and users need to pay attention to it. This is for any areas other than home.

## Russia Electromagnetic Interference (EMI) Class A statement

### ВНИМАНИЕ!

Настоящее изделие относится к оборудованию класса А. При использовании в бытовой обстановке это оборудование может нарушать функционирование других технических средств в результате создаваемых промышленных радиопомех. В этом случае от пользователя может потребоваться принятие адекватных мер.

## People's Republic of China Class A electronic emission statement

### 中华人民共和国“A类”警告声明

#### 声明

此为A级产品，在生活环境中，该产品可能会造成无线电干扰。在这种情况下，可能需要用户对其干扰采取切实可行的措施。

## Taiwan Class A compliance statement

警告使用者：  
這是甲類的資訊產品，在居住的環境中使用時，可能會造成射頻干擾，在這種情況下，使用者會被要求採取某些適當的對策。

## Taiwan BSMI RoHS declaration

| 單元 Unit   | 限用物質及其化學符號<br>Restricted substances and its chemical symbols |                  |                  |  |  |  |
|---|--|------------------|------------------|--|--|--|
|   | 鉛Lead<br>(Pb)  | 汞Mercury<br>(Hg) | 鎘Cadmium<br>(Cd) | 六價鉻<br>Hexavalent<br>chromium<br>(Cr <sup>6+</sup> ) | 多溴聯苯<br>Polybrominated<br>biphenyls<br>(PBB) | 多溴二苯醚<br>Polybrominated<br>diphenyl ethers<br>(PBDE) |
| 機架  | ○  | ○                | ○                | ○  | ○  | ○  |
| 外部蓋板  | ○  | ○                | ○                | ○  | ○  | ○  |
| 機械組零件   | -  | ○                | ○                | ○  | ○  | ○  |
| 空氣傳動設備  | -  | ○                | ○                | ○  | ○  | ○  |
| 冷卻組零件   | -  | ○                | ○                | ○  | ○  | ○  |
| 內存模塊  | -  | ○                | ○                | ○  | ○  | ○  |
| 處理器模塊   | -  | ○                | ○                | ○  | ○  | ○  |
| 電纜組零件   | -  | ○                | ○                | ○  | ○  | ○  |
| 電源  | -  | ○                | ○                | ○  | ○  | ○  |
| 儲備設備  | -  | ○                | ○                | ○  | ○  | ○  |
| 電路卡   | -  | ○                | ○                | ○  | ○  | ○  |
| 光碟機   | -  | ○                | ○                | ○  | ○  | ○  |
| 雷射器   | -  | ○                | ○                | ○  | ○  | ○  |
| <p>備考1. “超出0.1 wt %” 及 “超出0.01 wt %” 係指限用物質之百分比含量超出百分比含量基準值。<br/>           Note1 : “exceeding 0.1wt%” and “exceeding 0.01 wt%” indicate that the percentage content of the restricted substance exceeds the reference percentage value of presence condition.</p> <p>備考2. “○” 係指該項限用物質之百分比含量未超出百分比含量基準值。<br/>           Note2 : “○” indicates that the percentage content of the restricted substance does not exceed the percentage of reference value of presence.</p> <p>備考3. “-” 係指該項限用物質為排除項目。<br/>           Note3 : The “-” indicates that the restricted substance corresponds to the exemption.</p> |  |                  |                  |  |  |  |



---

# Index

## A

- accessing IMM2
  - remotely 43
- accessing the IMM2 43
- activity LED 13
- adapter-retention assembly
  - installing 832
  - removing 831
- adapters and UEFI drivers, Setup utility 26
- Advanced Settings Utility (ASU) 32
- array, SAS 856
- assistance, getting 893
- Attention notice, meaning 4
- Australia Class A statement 900

## B

- base assembly
  - installing 863
  - removing 863
  - replacing 863
- base assembly FRU 863
- bezel
  - installing 834
  - removing 833
- boot manager, Setup utility 26
- Boot Selection Menu program 32
- Brocade documentation 3
- button, power 13

## C

- Canada Class A electronic emission statement 900
- Cannot communicate with the CMM 800
- Cannot communicate with the I/O module 801
- Cannot communicate with the management node 800
- cannot connect during initial setup, troubleshooting 801
- Cannot log in to the CMM 803
- Cannot log in to the I/O module 803
- Cannot log in to the management node 803
- Cannot log in, troubleshooting 803
- Cannot ping the CMM, troubleshooting 803
- Cannot ping the I/O module, troubleshooting 806
- Cannot ping the management node, troubleshooting 807, 810
- Caution notice, meaning 4
- chassis bulkhead
  - installing 872
  - removing 871
- chassis management module 7
- check log LED 13
- China Class A electronic emission statement 902
- Class A electronic emission notice 900
- CMM cannot ping the CMM 805
- CMOS battery 18
  - installing 835
  - removing 834
- collecting service data 825
- commands on USB interface preference, Setup utility 26
- components
  - compute node, removing and replacing 827
  - illustrated 13
  - returning 828
  - system board 18
- compute node
  - installing 829

- parts list 51
- removing 828

- compute node cover
  - installing 838
  - removing 836
- compute node start problems 799
- configuration
  - minimum 824
  - updating 828
- configuration summary, viewing 45
- configuring
  - compute node 25
  - LAN over USB interface manually 49
  - RAID array 35
- configuring a RAID array 35
- conflicts, LAN over USB interface 48
- connectivity problems 800
- connectors, system board 18
- console breakout cable 16
- contamination, particulate and gaseous 899
- controller
  - Ethernet 7
  - memory 7
  - video 7
- controls 13
- cover
  - installing 838
  - removing 836
- creating a personalized support web page 894
- CRUs, Tier 1, removing and replacing 831
- CRUs, Tier 2, removing and replacing 863
- custom support web page 894

## D

- Danger notice, meaning 4
- defective node 863
- device drivers, updating 23
- device, returning 828
- devices and I/O ports, Setup utility 26
- diagnostic messages, DSA 65
- diagnostic tools 57
- diagnostics, light path 57
- dimensions, x440 Compute Node Types 7167 and 2590 5
- DIMM
  - installing 840
  - removing 839
  - specifications 5
- DIMM connectors 18
- disabling LAN over USB interface 48
- DMI/SMBIOS data, updating
  - locally: keyboard controller style 33
  - locally: LAN over USB 33
  - remotely over a LAN 34
- documentation
  - using 894
- Documentation Browser
  - requirements 3
  - using 3
- documentation CD 3
- documentation, Brocade 3
- documentation, related 2
- drive
  - option, SAS 856
  - option, SATA 856
- DSA
  - running 65

- text messages 65
- viewing test results 66
- DSA diagnostics
  - overview 65
- DSA log 202
- DSA, sending data 894
- Dynamic system analysis diagnostics, *See* DSA

## E

- electronic emission Class A notice 900
- Electronic Service Agent (ESA) 825
- error codes 202
  - IMM 202
  - IMM2 202
  - UEFI diagnostic codes 775
- error symptoms
  - hard disk drive 814
  - software 824
- errors
  - connectivity 800
  - memory 816
  - observable problems 817
  - software 824
- Ethernet controller 7
- European Union EMC Directive conformance statement 900
- event log
  - IMM2 63
- event log IMM2, viewing through Setup utility 63
- event logs 202
  - viewing without restarting compute node 63

## F

- fabric connector
  - installing 875
  - location 18
  - removing 874
- fault LED 13
- FCC Class A notice 900
- features
  - ServerGuide 40
- features, compute node 7
- field replaceable unit (FRU) 827
- fields, UEFI diagnostic code 775
- filler, node bay 829
- finding the UEFI diagnostic code 776
- firmware
  - recovering from update failure 24
  - updating 23
- Flex System x440 Compute Node introduction 1
- Force legacy video on boot, Setup utility 26
- front handle
  - installing 852
  - removing 852

## G

- gaseous contamination 899
- Germany Class A statement 901
- guidelines
  - installation 827
  - system reliability 827

## H

- handle, front
  - installing 852
  - removing 852

- hard disk drive
  - problems 814
  - specifications 7
  - support 7
- hard disk drive backplane
  - installing 855
  - removing 853
- hard disk drive cage
  - installing 873
  - removing 873
- hard disk drives
  - hot swap, installing 856
  - specifications 7
  - support 7
- hardware and software requirements 3
- hardware service and support telephone numbers 895
- HDD backplane connector 18
- heat sink
  - installing 880
  - removing 876
  - thermal grease 888
- help
  - from the World Wide Web 894
  - from World Wide Web 894
  - sending diagnostic data 894
  - sources of 893
- host server startup sequence, changing 45
- hot-swap hard disk device
  - SAS hard disk drive 856
  - SATA hard disk drive 856
- hot-swap hard disk drive
  - installing 856
  - removing 856
- hot-swap hard disk drive backplane
  - installing 855
  - removing 853
- hot-swap hard disk drive cage
  - removing 873

## I

- identify LED 13
- IMM2
  - accessing 48
  - action descriptions 45
  - clearing the system event log 26
  - IP addresses, LAN over USB 48
  - MAC address and hostname 43
  - network access tag 43
  - reset to defaults 26
  - Setup utility 26
  - system event log, viewing through Setup utility 63
  - viewing the system event log 26
- IMM2 Web interface
  - logging in 44
- Important notice, meaning 4
- important notices 898
- indicators 13
- information center 894
- installation guidelines 827
- installing
  - bezel 834
  - compute node 829
  - hot-swap hard disk drives 856
  - optional devices 827
  - SAS hard disk drive 856
  - SATA hard disk drive 856
- installing an operating system
  - without ServerGuide 41
- installing an operating system, typical 41
- installing an optional device 827
- integrated management module, *See* IMM2

intermittent connectivity problems 815  
intermittent problems 814  
introduction, Flex System x440 Compute Node 1  
I/O expansion adapter  
  installing 858  
  removing 857  
I/O expansion connectors 18  
IP addresses, LAN over USB 48

## J

Japanese electromagnetic compatibility statements 902  
jumpers, system board 18

## K

KCS address, IMM2 48  
keyboard controller style address, IMM2 48  
Korea Class A electronic emission statement 902

## L

LAN over USB  
  IP addresses 48  
  Linux driver installation 50  
  Windows driver installation 49  
LAN over USB interface  
  configuring manually 49  
  conflicts 48  
  disabling interface 48  
  resolving conflicts 48  
LEDs  
  activity 13  
  check log 13  
  CMOS battery error 19  
  DIMMs 19  
  fault 13  
  identify 13  
  I/O expansion adapter 19  
  microprocessor 19  
  power 13  
  SAS backplane 19  
  system board 19  
  viewing light path 57  
LEDs, light path diagnostic 59  
legacy support, Setup utility 26  
legacy Think support, Setup utility 26  
Lenovo XClarity Administrator 11  
light path diagnostic LEDs, viewing 57  
light path diagnostics 57  
light path diagnostics LEDs 59  
light path diagnostics panel 19  
  installing 860  
  removing 859  
Linux driver installation, LAN over USB 50  
load-sharing  
  power throttling 7  
logging on to the IMM2 Web interface 44  
Logic Configuration Utility, LSI 36  
LSI Logic Configuration Utility program 36

## M

MAC address 43  
MAC address label 43  
major components  
  system board 13  
memory  
  specifications 5

memory mirroring 840  
memory module  
  installing 840  
  removing 839  
  specifications 7  
memory problems 816  
memory, Setup utility 26  
messages  
  IMM 202  
  UEFI diagnostic codes 775  
microprocessor  
  installing 880  
  removing 876  
  specifications 5  
  thermal grease 888  
microprocessor connector 18  
microprocessor-retention assembly  
  installing 890  
  removing 889  
minimum configuration 824  
Multiple nodes cannot ping the CMM 804  
Multiple nodes cannot ping the I/O module 806  
Multiple nodes cannot ping the management node 808, 810,  
  812–813  
Multiple nodes cannot ping the management node in a  
  different chassis 809, 812  
multiple nodes do not power on 823

## N

network access tag 43  
network configuration, Setup utility 26  
network, Setup utility 26  
New Zealand Class A statement 900  
node bay filler 829  
notes, important 898  
notices 897  
  electronic emission 900  
  FCC, Class A 900

## O

observable problems 817  
one compute node experiences a sudden loss of  
  connectivity 802  
one compute node is unable to connect during the initial  
  setup 801  
one or more compute nodes is unable to communicate  
  with SAN 801  
operating modes, Setup utility 26  
operating system  
  installing 39–40  
operating system installation  
  with ServerGuide 41  
  without ServerGuide 41  
optional device and FRU installation problems 819  
optional devices, installing 827

## P

particulate contamination 899  
parts listing 51  
People's Republic of China Class A electronic emission  
  statement 902  
performance problems 820  
periscope connector  
  installing 875  
  removing 874  
POST  
  event viewer 26

- POST event log 202
- POST watchdog timer, Setup utility 26
- power
  - throttling 7
  - power button 13
  - power LED 13
  - power off 13
  - power on 13
  - power-on problems 821, 823
    - compute node does not power off 823
    - single node does not power on 822
- power, Setup utility 26
- problems
  - compute node start 799
  - connectivity 800
  - hard disk drive 814
  - intermittent 814
  - intermittent connectivity 815
  - memory 816
  - multiple nodes do not power on 823
  - observable problems 817
  - optional device and FRU installation 819
  - performance 820
  - power-on 821, 823
    - compute node does not power off 823
    - single node does not power on 822
  - software 824
  - undetermined 824
- problems, solving 57
- processors, Setup utility 26
- product service, Taiwan 895
- publications CD 3
- publications, Brocade 3
- publications, related 2
- PXE Boot Agent 45
- PXE boot protocol, setting 31

## R

- reboot system on NMI, Setup utility 26
- redundant array of independent disks (RAID)
  - SAS array 856
- rehook INT, Setup utility 26
- related documentation 2
- reliability
  - features 12
  - RAS features 12
- remotely accessing IMM2 43
- removing
  - bezel 833
  - compute node 828
  - front handle 852
  - hot-swap hard disk drive 856
- removing and replacing compute node components 827
- removing and replacing CRUs 831, 863
- replacing
  - thermal grease 888
- requirements
  - hardware 3
  - hardware and software 3
  - software 3
- returning a device or component 828
- RFID tag 1
- Russia Class A electronic emission statement 902

## S

- safety iii
- safety statements iii-iv
- SAS array, type supported 856
- SAS hard disk drive
  - hot-swap hard disk device 856

- installing 856
- SAS ID address 43
- SATA hard disk drive
  - hot-swap hard disk device 856
  - installing 856
- scripting toolkit, ServerGuide 41
- SCSI 856
- sending diagnostic data 894
- Serial Attached SCSI (SAS)
  - hot-swap hard disk drive
    - installing 856
    - removing 856
- ServerGuide
  - features 40
  - using to install operating system 41
- ServerGuide CD 7
- ServerGuide scripting toolkit 41
- service and support
  - before you call 893
  - hardware 895
  - software 894
- Service and Support Manager 825
- service bulletins 57
- setting the PXE boot protocol 31
- setting up the LAN-on-motherboard (LOM) feature 36
- Setup utility
  - menu 26
  - overview 26
- Single node cannot ping the CMM 804
- Single node cannot ping the I/O module 806
- Single node cannot ping the management node 807, 810
- Single node cannot ping the management node, different chassis 808, 811
- SMBIOS data, updating
  - locally: keyboard controller style 33
  - locally: LAN over USB 33
  - remotely over a LAN 34
- software problems 824
- software service and support telephone numbers 894
- solving hardware and software problems 57
- specifications
  - x440 Compute Node Types 7167 and 2590 5
- start options, Setup utility 26
- starting the compute node 16
- startup sequence, changing 45
- static electricity 828
- static-sensitive devices, handling 828
- stopping the compute node 17
- storage drive
  - problems 814
- support web page, custom 894
- switches, system board 20
- symptom, troubleshooting 799
- system board
  - connectors 18
  - jumpers 18
  - layouts 18
  - LEDs 19
  - switches 20
- system event log 202
- system event logs, Setup utility 26
- system information, Setup utility 26
- system reliability guidelines 827
- system security, Setup utility 26
- system settings, Setup utility 26
- system summary, Setup utility 26
- system-board assembly
  - components 13
- systems management
  - chassis management module 7
  - Flex System Manager management software 7



## T

- Taiwan BSMI RoHS declaration 903
- Taiwan Class A electronic emission statement 902
- Taiwan product service 895
- telecommunication regulatory statement 899
- telephone numbers 894–895
- test results, viewing DSA 66
- thermal grease, replacing 888
- Tier 1 CRU 827
- Tier 1 CRUs, removing and replacing 831
- Tier 2 CRU 827
- Tier 2 CRUs, removing and replacing 863
- tools, diagnostic 57
- TPM
  - Setup utility 26
- trademarks 898
- troubleshooting 57
  - service bulletins 57
- troubleshooting by symptom 799
- troubleshooting tables 799
- Troubleshooting, cannot communicate with the CMM 800
- Troubleshooting, cannot communicate with the I/O module 801
- Troubleshooting, cannot communicate with the management node 800
- troubleshooting, cannot connect during initial setup 801
- Troubleshooting, cannot log in 803
- Troubleshooting, cannot log in to the CMM 803
- Troubleshooting, cannot log in to the I/O module 803
- Troubleshooting, cannot log in to the management node 803
- Troubleshooting, cannot ping the CMM 803
- Troubleshooting, cannot ping the I/O module 806
- Troubleshooting, cannot ping the management node 807, 810
- Troubleshooting, CMM cannot ping the CMM 805
- Troubleshooting, multiple nodes cannot ping the CMM 804
- Troubleshooting, multiple nodes cannot ping the I/O module 806
- Troubleshooting, multiple nodes cannot ping the management node 808, 810, 812–813
- Troubleshooting, multiple nodes cannot ping the management node in a different chassis 809, 812
- troubleshooting, one compute node experiences a sudden loss of connectivity 802
- troubleshooting, one compute node is unable to connect during the initial setup 801
- troubleshooting, one or more compute nodes is unable to communicate with SAN 801
- Troubleshooting, single node cannot ping the CMM 804
- Troubleshooting, single node cannot ping the I/O module 806
- Troubleshooting, single node cannot ping the management node 807, 810
- Troubleshooting, single node cannot ping the management node, different chassis 808, 811
- troubleshooting, two or more compute nodes are unable to communicate during initial setup 802
- troubleshooting, two or more compute nodes experience a sudden loss of connectivity 803

- trusted platform module, Setup utility 26
- turning off the compute node 17
- turning on the compute node 16
- two or more compute nodes are unable to communicate during initial setup 802
- two or more compute nodes experience a sudden loss of connectivity 803

## U

- UEFI diagnostic code fields 775
- UEFI diagnostic code, finding 776
- UEFI diagnostic codes 775
- UEFI drivers, Setup utility 26
- UEFI events 202
- UEFI firmware
  - recovering from update failure 24
  - updating 23
  - updating using Flex System Manager Chassis Manager 23
  - updating using ToolsCenter Bootable Media Creator 23
  - updating using UpdateXpress 23
- unable to communicate 800
- undetermined problems 824
- United States FCC Class A notice 900
- updating
  - configuration 828
  - device drivers 23
  - firmware 23
- USB flash drive
  - installing 862
  - removing 861
- user security, Setup utility 26

## V

- viewing DSA test results 66
- Virtual Light Path 45

## W

- Web interface
  - logging in 44
- weight, x440 Compute Node Types 7167 and 2590 5
- Windows driver installation, LAN over USB 49

## X

- x440 Compute Node Types 7167 and 2590
  - dimensions 5
  - specifications 5
  - weight 5







Part Number: 00YJ281

Printed in China

(1P) P/N: 00YJ281

