



## Flex System x220 Compute Node Product Guide

The Flex System™ x220 Compute Node is the next generation cost-optimized compute node designed for less demanding workloads and low-density virtualization. The x220 is efficient and equipped with flexible configuration options and advanced management to run a broad range of workloads.

*Suggested use:* For clients looking to deploy an entry virtualization solution as part of a larger data center infrastructure.

The following figure shows the Flex System x220 Compute Node.



Figure 1. The Flex System x220 Compute Node

### Did you know?

Lenovo Flex System is a new category of computing that integrates multiple server architectures, networking, storage, and system management capability into a single system that is easy to deploy and manage. Flex System has full and built-in virtualization support of servers, storage, and networking to speed provisioning and increased resiliency. In addition, it supports open industry standards, such as operating systems, networking and storage fabrics, virtualization, and system management protocols, to easily fit within existing and future data center environments. Flex System is scalable and extendable with multigenerational upgrades to protect and maximize IT investments.

## Key features

The Flex System x220 Compute Node is a high-availability, scalable compute node optimized to support the next-generation microprocessor technology. With a balance between cost and system features, the x220 is an ideal platform for general business workloads. This section describes the key features of the server.

### Scalability and performance

The x220 offers numerous features to boost performance, improve scalability, and reduce costs:

- The Intel Xeon processor E5-2400 product family improves productivity by offering affordable dual-socket system performance with eight-core processors with up to 2.3 GHz core speeds, up to 20 MB of L3 cache, and one QPI interconnect link of up to 8 GTps.
- Up to two processors, 16 cores total, and 32 threads maximize the concurrent execution of multithreaded applications.
- Intelligent and adaptive system performance with Intel Turbo Boost Technology 2.0 allows processor cores to run at maximum speeds during peak workloads by temporarily going beyond processor Thermal Design Power (TDP).
- Intel Hyper-Threading Technology boosts performance for multithreaded applications by enabling simultaneous multithreading within each processor core, up to two threads per core.
- Intel Virtualization Technology integrates hardware-level virtualization hooks that allow operating system vendors to better use the hardware for virtualization workloads.
- Intel Advanced Vector Extensions (AVX) improve floating point performance for compute-intensive technical and scientific applications compared to Intel Xeon 5600 series processors.
- There are 12 DIMM sockets supporting low profile (LP) RDIMMs, UDIMMs and LRDIMMs, with a total capacity of up to 384 GB using 32 GB LRDIMMs
- Supports memory speeds of up to 1600 MHz to maximize memory performance.
- Support for 1.8-inch solid-state drives to maximize I/O operations per second (IOPS) and significantly improve application performance.
- Supports the Storage Expansion Node providing an additional 12 hot-swap 2.5-inch drive bays for local storage.
- The theoretical maximum memory bandwidth of the Intel Xeon processor E5-2400 product family is 38.4 GBps, which is 20% more than in the previous generation of Intel Xeon 5600 processors.
- The server offers PCI Express 3.0 I/O expansion capabilities that improve the theoretical maximum bandwidth by 60% (8 GTps per link) compared to the previous generation of PCI Express 2.0.
- With Intel Integrated I/O Technology, the PCI Express 3.0 controller is integrated into the Intel Xeon processor E5 family. This integration reduces I/O latency and increases overall system performance.
- Support for high-bandwidth I/O adapters, up to two in each x220 Compute Node. Support for 10 Gb Ethernet, 16 Gb Fibre Channel, and FDR InfiniBand expansion cards.
- Supports the PCIe Expansion Node for support for up to six additional I/O adapters.

### Availability and serviceability

The x220 provides many features to simplify serviceability and increase system uptime:

- Chipkill, memory mirroring, and memory rank sparing for redundancy in the event of a non-correctable memory failure.
- Tool-less cover removal provides easy access to upgrades and serviceable parts, such as processor, memory, and adapter cards.
- Hot-swap drives supporting integrated RAID 1 redundancy for data protection and greater system uptime.
- A light path diagnostics panel and individual light path LEDs lead the technician to failed (or failing) components. These features simplify servicing, speeds up problem resolution, and helps improve system availability.
- Predictive Failure Analysis (PFA) detects when system components (such as processors, memory, and hard disk drives) operate outside of standard thresholds and generates proactive alerts in advance of possible failure, therefore increasing uptime.

- Solid-state drives (SSDs), which offer significantly better reliability than traditional mechanical HDDs for greater uptime.
- A built-in Integrated Management Module II (IMM2) continuously monitors system parameters, triggers alerts, and performs recovery actions in case of failures to minimize downtime.
- Built-in diagnostics using Dynamic Systems Analysis (DSA) Preboot speeds up troubleshooting tasks to reduce service time.
- Three-year customer replaceable unit and on-site limited warranty, next business day 9x5. Optional service upgrades are available.

### **Manageability and security**

Powerful systems management features simplify local and remote management of the x220:

- The server includes an Integrated Management Module II (IMM2) to monitor server availability and perform remote management.
- An integrated industry-standard Unified Extensible Firmware Interface (UEFI) enables improved setup, configuration, and updates, and simplifies error handling.
- Integrated Trusted Platform Module (TPM) V 1.2 support enables advanced cryptographic functionality, such as digital signatures and remote attestation.
- Industry-standard AES NI support for faster, stronger encryption.
- Integrates with the IBM® Flex System™ Manager for proactive systems management. It offers comprehensive systems management for the entire Flex System platform, increasing uptime, reducing costs, and improving productivity through advanced server management capabilities.
- Fabric Manager simplifies the deployment of infrastructure connections by managing network and storage address assignments.
- Intel Execute Disable Bit functionality can help prevent certain classes of malicious buffer overflow attacks when combined with a supporting operating system.
- Intel Trusted Execution Technology provides enhanced security through hardware-based resistance to malicious software attacks, allowing an application to run in its own isolated space protected from all other software running on a system.

### **Energy efficiency**

The x220 offers the following energy-efficiency features to save energy, reduce operational costs, increase energy availability, and contribute to a green environment:

- Component-sharing design of the Flex System chassis provides ultimate power and cooling savings.
- The Intel Xeon processor E5-2400 product family offers better performance over the previous generation while fitting into the same TDP limits.
- Intel Intelligent Power Capability powers individual processor elements on and off as needed, to reduce power draw.
- Low-voltage Intel Xeon processors draw less energy to satisfy demands of power and thermally constrained data centers and telecommunication environments.
- Low-voltage 1.35 V DDR3 memory RDIMMs consume 15% less energy than 1.5 V DDR3 RDIMMs.
- Solid-state drives (SSDs) consume as much as 80% less power than traditional spinning 2.5-inch HDDs.
- The server uses hexagonal ventilation holes, a part of IBM Calibrated Vecteded Cooling™ technology. Hexagonal holes can be grouped more densely than round holes, providing more efficient airflow through the system.

## Locations of key components and connectors

The following figure shows the front of the server.

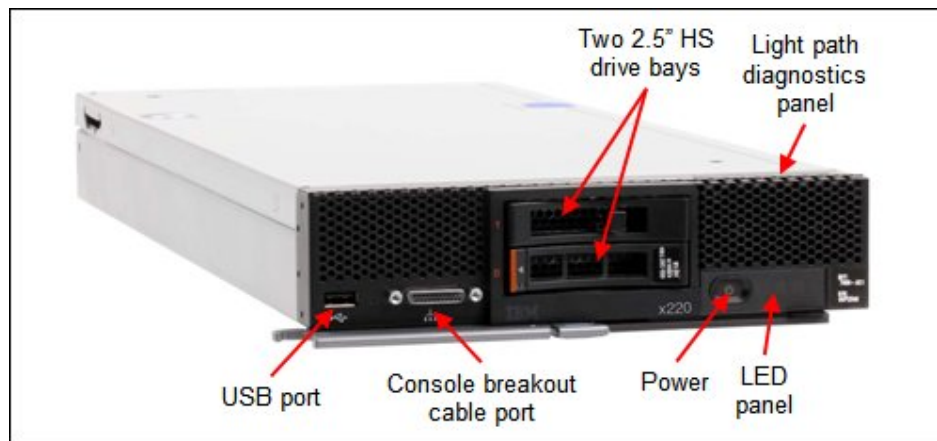

Figure 2. Front view of the Flex System x220 Compute Node

The following figure shows the locations of key components inside the server.

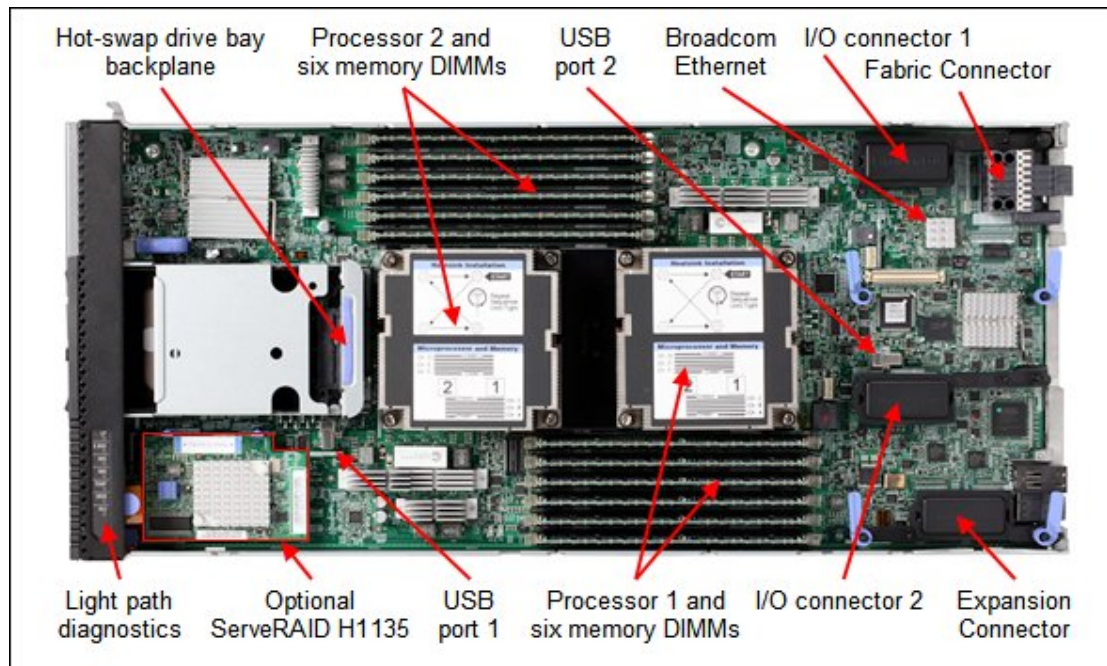

Figure 3. Inside view of the Flex System x220 Compute Node

## Standard specifications

The following table lists the standard specifications.

Table 1. Standard specifications

Components	Specification
Form factor	Standard-width compute node.
Chassis support	Flex System Enterprise Chassis.

Components	Specification
Processor	Up to two Intel Xeon Processor E5-2400 product family processors with eight-core (up to 2.3 GHz), six-core (up to 2.4 GHz), or quad-core (up to 2.2 GHz), one QPI link running at 8.0 GTps, L3 cache up to 20 MB, and memory speeds up to 1600 MHz. The server also supports one Intel Pentium Processor 1400 product family processor with two cores, up to 2.8 GHz, 5 MB L3 cache, and 1066 MHz memory speeds.
Chipset	Intel C600 series.
Memory	Up to 12 DIMM sockets (six DIMMs per processor) using Low Profile (LP) DDR3 DIMMs. RDIMMs, UDIMMs and LRDIMMs are supported. 1.5 V and low-voltage 1.35 V DIMMs are supported. Support for up to 1600 MHz memory speed, depending on the processor. Three memory channels per processor (two DIMMs per channel). Supports two DIMMs per channel operating at 1600 MHz (2 DPC @ 1600 MHz) with single and dual rank RDIMMs.
Memory maximums	With LRDIMMs: Up to 384 GB with 12x 32 GB LRDIMMs and two E5-2400 processors. With RDIMMs: Up to 192 GB with 12x 16 GB RDIMMs and two E5-2400 processors. With UDIMMs: Up to 48 GB with 12x 4 GB UDIMMs and two E5-2400 processors. Half of these maximums and DIMMs counts with one processor installed.
Memory protection	ECC, Chipkill (for x4-based memory DIMMs), and optional memory mirroring and memory rank sparing.
Disk drive bays	Two 2.5-inch hot-swap SAS/SATA drive bays supporting SAS, SATA, and SSD drives. Optional support for an additional four 1.8" SSDs mounted internally. Onboard ServeRAID C105 supports SATA drives only. Up to 12 additional 2.5-inch drive bays with the optional Storage Expansion Node.
Maximum internal storage	With two 2.5-inch hot-swap drives (intermix of SAS and SATA HDDs and SSDs is supported): * Up to 2 TB with 1 TB 2.5-inch NL SAS HDDs * Up to 2.4 TB with 1.2 TB 2.5-inch SAS HDDs * Up to 2 TB with 1 TB 2.5-inch NL SATA HDDs * Up to 3.2 TB with 1.6 TB 2.5-inch SATA SSDs. With 1.8-inch SSDs internally and ServeRAID M5115 RAID adapter: * Up to 4.8 TB with two 1.6 TB 2.5-inch SATA SSDs and four 400 GB 1.8-inch SSDs.
RAID support	Software RAID 0 and 1 with integrated LSI-based 3 Gbps ServeRAID C105 controller; supports SATA drives only. Non-RAID not supported. Optional ServeRAID H1135 RAID adapter with LSI SAS2004 controller, supports SAS/SATA drives with hardware-based RAID 0 and 1. An H1135 adapter is installed in a dedicated PCIe 2.0 x4 connector and does not use either I/O adapter slot. Optional ServeRAID M5115 RAID adapter with RAID 0, 1, 10, 5, 50 support and 1 GB cache. M5115 uses the I/O adapter slot 1. Can be installed in all models, including models with embedded a 1 GbE with Fabric connector. Supports up to eight 1.8-inch SSD with expansion kits. Optional flash-backup for cache, RAID 6/60, and SSD performance enabler.
Network interfaces	Some models (see <a href="#">Table 2</a> ): Embedded dual-port Broadcom BCM5718 Ethernet Controller that supports Wake on LAN and Serial over LAN, IPv6. TCP/IP Offload Engine (TOE) not supported. Routes to chassis I/O module bays 1 and 2 through a Fabric Connector to the chassis midplane. The Fabric Connector precludes the use of I/O adapter slot 1, with the exception that the M5115 can be installed in slot 1 while the Fabric Connector is installed. Remaining models: No network interface standard; optional 1 Gb or 10 Gb Ethernet adapters.
PCI Expansion slots	Two connectors for I/O adapters; each connector has PCIe x8+x4 interfaces. Includes an Expansion Connector (PCIe 3.0 x16) to connect an expansion node such as the PCIe Expansion Node Dedicated PCIe 2.0 x4 interface for ServeRAID H1135 adapter only. PCIe Expansion Node supports two full-height PCIe adapters, two low-profile PCIe adapters and two Flex System I/O adapters.
Ports	USB ports: One external and two internal ports for an embedded hypervisor. A console breakout cable port on the front of the server provides local KVM and serial ports (cable standard with chassis; additional cables optional).
Optical drive bays	No internal bays; use an external USB drive. See <a href="http://support.lenovo.com/en/documents/pd011281">http://support.lenovo.com/en/documents/pd011281</a> for options.
Systems management	UEFI, Integrated Management Module 2 (IMM2) with Renesas SH7757 controller, Predictive Failure Analysis, light path diagnostics panel, automatic server restart, and remote presence. Support for Flex System Manager, IBM Systems Director, and ServerGuide.

Components	Specification
Security features	Power-on password, administrator's password, and Trusted Platform Module V1.2.
Video	Matrox G200eR2 video core with 16 MB video memory integrated into the IMM2. Maximum resolution is 1600x1200 at 75 Hz with 16 M colors.
Limited warranty	Three-year customer-replaceable unit and on-site limited warranty with 9x5/NBD.
Operating systems supported	Microsoft Windows Server 2008 R2, Red Hat Enterprise Linux 5 and 6, SUSE Linux Enterprise Server 10 and 11, VMware ESX 4.1 and 5. See "Supported operating systems" for details.
Service and support	Optional service upgrades are available through ServicePac® offerings: 4-hour or 2-hour response time, 8-hour fix time, 1-year or 2-year warranty extension, remote technical support for hardware and selected and original equipment manufacturer (OEM) software.
Dimensions	Width: 217 mm (8.6 in.), height: 56 mm (2.2 in.), depth: 492 mm (19.4 in.)
Weight	Maximum configuration: 6.4 kg (14.11 lb).

The x220 servers are shipped with the following items:

- Statement of Limited Warranty
- Important Notices
- Documentation CD that contains the *Installation and User's Guide*

## Standard models

The following table lists the standard models.

Table 2. Standard models

Model	Intel Processor** E5-2400: 2 maximum Pentium 1400: 1 max	Memory	RAID	Disk bays†	Disks	1 GbE Embed‡	I/O slots (used/max)
7906-A2x	1x Intel Pentium 1403 2C 2.6 GHz 5 MB 1066 MHz 80W	1x 4GB 1066 MHz* UDIMM	C105	2x 2.5-inch hot-swap	Open	Standard	1 / 2‡
7906-B2x	1x Intel Xeon E5-2430L 6C 2.0 GHz 15 MB 1333 MHz 60W	1x 4GB 1333 MHz UDIMM	C105	2x 2.5-inch hot-swap	Open	Standard	1 / 2‡
7906-C2x	1x Intel Xeon E5-2403 4C 1.8 GHz 10 MB 1066 MHz 80W	1x 4GB 1066 MHz* RDIMM	C105	2x 2.5-inch hot-swap	Open	Standard	1 / 2‡
7906-D2x	1x Intel Xeon E5-2420 6C 1.9 GHz 15 MB 1333 MHz 95W	1x 4GB 1333 MHz RDIMM	C105	2x 2.5-inch hot-swap	Open	Standard	1 / 2‡
7906-F2x	1x Intel Xeon E5-2418L 4C 2.0GHz 10MB 1333MHz 50W	1x 4GB 1333 MHz RDIMM	C105	2x 2.5-inch hot-swap	Open	Standard	1 / 2‡
7906-G2x	1x Intel Xeon E5-2430 6C 2.2 GHz 15 MB 1333 MHz 95W	1x 4GB 1333 MHz RDIMM	C105	2x 2.5-inch hot-swap	Open	No	0 / 2
7906-G4x	1x Intel Xeon E5-2430 6C 2.2 GHz 15 MB 1333 MHz 95W	1x 4GB 1333 MHz RDIMM	C105	2x 2.5-inch hot-swap	Open	Standard	1 / 2‡
7906-H2x	1x Intel Xeon E5-2440 6C 2.4 GHz 15 MB 1333 MHz 95W	1x 4GB 1333 MHz RDIMM	C105	2x 2.5-inch hot-swap	Open	Standard	1 / 2‡
7906-J2x	1x Intel Xeon E5-2450 8C 2.1 GHz 20 MB 1600 MHz 95W	1x 4GB 1333 MHz* RDIMM	C105	2x 2.5-inch hot-swap	Open	No	0 / 2
7906-L2x	1x Intel Xeon E5-2470 8C 2.3 GHz 20 MB 1600 MHz 95W	1x 4GB 1333 MHz* RDIMM	C105	2x 2.5-inch hot-swap	Open	No	0 / 2
7906-DBx§	2x Intel Xeon E5-2420 6C 1.9 GHz 15 MB 1333 MHz 95W	2x 4GB 1333 MHz RDIMM	C105	14x 2.5-inch hot-swap with Storage Expansion Node§	Open	Standard	1 / 2‡

\*\* Processor details: Processor quantity and model, cores, core speed, L3 cache, memory speed, and power consumption.

\* For model A2x and C2x, the standard DIMM is rated at 1333 MHz, but operates at up to 1066 MHz to match the processor memory speed. Conversely, for models J2x and L2x, the processor memory speed is rated at 1600 MHz, but operates up to 1333 MHz to match the rated speed of the installed DIMM. Actual memory speed maximums depend on several factors, as described in "Memory options".

† The 2.5-inch drive bays can be replaced and expanded with a new backplane and a ServeRAID M5115 RAID controller to support up to eight 1.8-inch solid-state drives (SSDs).

‡ These models include an Embedded 1 Gb Ethernet controller. Connections are routed to the chassis midplane using a Fabric Connector. The Fabric Connector precludes the use of an I/O adapter in I/O connector 1 (with the exception of the ServeRAID M5115 RAID controller).

§ Model DBx is optimized as a Network Attached Storage (NAS) offering and includes the Flex System Storage Expansion Node (68Y8588) as standard

Model 7906-DBx is a new Network Attached Storage (NAS) optimized model that includes the x220 compute node and the Flex System Storage Expansion Node connected together as a single unit at the factory. This single model number enables a simpler acquisition for both business partners and direct sales. The combination of the x220 compute node and the storage node is certified with Windows Storage Server 2012 meaning that this configuration is an excellent foundation for a low cost NAS solution. Windows Storage Server 2012 is available via the Reseller Option Kit (ROK) program using part number 00Y6302. Model DBx does not include drives giving you maximum flexibility when it comes to selecting drives, either SAS or SATA disk drives or high-performance solid-state drives.

## Chassis support

The x220 is supported in the Flex System Enterprise Chassis. Up to 14 x220 Compute Nodes can be installed in the chassis (10U of rack space).

## Processor options

The x220 supports the processor options listed in the following table. The server supports one or two Intel Xeon E5-2400 processors, but the server supports only one Intel Pentium 1403 or 1407 processor or E5-1410 processor. The table also shows which server models have each processor standard. If no corresponding *where used* model for a particular processor is listed, then this processor is available only through configure-to-order (CTO) process.

Table 3. Processor options

Part number	Feature code*	Intel Xeon processor description	Models where used
Intel Pentium processors			
None	A1VZ / None	Intel Pentium 1403 2C 2.6 GHz 5 MB 1066 MHz 80 W	A2x
None*	A1W0 / None	Intel Pentium 1407 2C 2.8 GHz 5 MB 1066 MHz 80 W	-
Intel Xeon processors			
None*	A3C4 / None	Intel Xeon E5-1410 4C 2.8GHz 10MB 1333MHz 80W	-
90Y4801	A1VY / A1WC	Intel Xeon E5-2403 4C 1.8 GHz 10 MB 1066 MHz 80 W	C2x
90Y4800	A1VX / A1WB	Intel Xeon E5-2407 4C 2.2 GHz 10 MB 1066 MHz 80 W	-
90Y4799	A1VW / A1WA	Intel Xeon E5-2420 6C 1.9 GHz 15 MB 1333 MHz 95 W	D2x, DBx
90Y4797	A1VU / A1W8	Intel Xeon E5-2430 6C 2.2 GHz 15 MB 1333 MHz 95 W	G2x, G4x
90Y4796	A1VT / A1W7	Intel Xeon E5-2440 6C 2.4 GHz 15 MB 1333 MHz 95 W	H2x
90Y4795	A1VS / A1W6	Intel Xeon E5-2450 8C 2.1 GHz 20 MB 1600 MHz 95 W	J2x
90Y4793	A1VQ / A1W4	Intel Xeon E5-2470 8C 2.3 GHz 20 MB 1600 MHz 95 W	L2x
Intel Xeon processors - Low power			
00D9528	A3C7 / A3CA	Intel Xeon E5-2418L 4C 2.0GHz 10MB 1333MHz 50W	F2x
00D9527	A3C6 / A3C9	Intel Xeon E5-2428L 6C 1.8GHz 15MB 1333MHz 60W	-
90Y4805	A1W2 / A1WE	Intel Xeon E5-2430L 6C 2.0 GHz 15 MB 1333 MHz 60 W	B2x
00D9526	A3C5 / A3C8	Intel Xeon E5-2448L 8C 1.8GHz 20MB 1600MHz 70W	-
90Y4804	A1W1 / A1WD	Intel Xeon E5-2450L 8C 1.8 GHz 20 MB 1600 MHz 70 W	-

\* The Intel Pentium 1407 and Intel Xeon E5-1410 are available through CTO or special bid only.

\*\* The first feature code is for processor 1 and second feature code is for processor 2

## Memory options

Lenovo DDR3 memory is compatibility tested and tuned for optimal performance and throughput. Lenovo memory specifications are integrated into the light path diagnostics for immediate system performance feedback and optimum system uptime. From a service and support standpoint, Lenovo memory automatically assumes the system warranty, and Lenovo provides service and support worldwide.

The x220 supports Low Profile (LP) DDR3 memory RDIMMs, UDIMMs and LRDIMMs. The server supports up to six DIMMs when one processor is installed and up to 12 DIMMs when two processors are installed. Each processor has three memory channels, and there are two DIMMs per channel.

The following rules apply when selecting the memory configuration:

- Mixing 1.5 V and 1.35 V DIMMs in the same server is supported, but all DIMMs operate at 1.5 V.
- The maximum number of ranks supported per channel is eight.
- The maximum quantity of DIMMs that can be installed in the server depends on the number of processors, as shown in the "Max. qty supported" row in the following table.



- All DIMMs in all processor memory channels operate at the same speed, which is determined as the lowest value of:
  - Memory speed supported by a specific processor.
  - Lowest maximum operating speed for the selected memory configuration that depends on rated speed, as shown under the "Max. operating speed" section in the following table. The shaded cells indicate that the speed indicated is the maximum that the DIMM allows.

The following table shows the maximum memory speeds that are achievable based on the installed DIMMs and the number of DIMMs per channel. The table also shows maximum memory capacity at any speed supported by the DIMM and maximum memory capacity at rated DIMM speed. In the table, cells highlighted with a grey background indicate when the specific combination of DIMM voltage and number of DIMMs per channel still allows the DIMMs to operate at rated speed.

Table 4. Maximum memory speeds (Part 1: UDIMMs and LRDIMMs)

Spec	UDIMMs				LRDIMMs	
	Single rank		Dual rank		Quad rank	
Rank						
Part numbers	49Y1403 (2 GB)		49Y1404 (4 GB)		90Y3105 (32 GB)	
Rated speed	1333 MHz		1333 MHz		1333 MHz	
Rated voltage	1.35 V		1.35 V		1.35 V	
Operating voltage	1.35 V	1.5 V	1.35 V	1.5 V	1.35 V	1.5 V
Max quantity*	12	12	12	12	12	12
Largest DIMM	2 GB	2 GB	4 GB	4 GB	32 GB	32 GB
Max memory capacity	24 GB	24 GB	48 GB	48 GB	384 GB	384 GB
Max memory at rated speed	12 GB	12 GB	24 GB	24 GB	N/A	192 GB
<b>Maximum operating speed (MHz)</b>						
1 DIMM per channel	1333 MHz	1333 MHz	1333 MHz	1333 MHz	1066 MHz	1333 MHz
2 DIMMs per channel	1066 MHz	1066 MHz	1066 MHz	1066 MHz	1066 MHz	1066 MHz

\* The maximum quantity supported is shown for two processors installed. When one processor is installed, the maximum quantity supported is half of that shown.

Table 5. Maximum memory speeds (Part 2: RDIMMs)

Spec	RDIMMs							
	Single rank			Dual rank			Quad rank	
Part numbers	49Y1406 (4 GB)		49Y1559 (4 GB)	49Y1407 (4 GB) 49Y1397 (8 GB) 49Y1563 (16 GB)		90Y3178 (4 GB) 90Y3109 (8 GB) 00D4968 (16 GB)		49Y1400 (16 GB)
Rated speed	1333 MHz		1600 MHz	1333 MHz		1600 MHz		1066 MHz
Rated voltage	1.35 V		1.5 V	1.35 V		1.5 V		1.35 V
Operating voltage	1.35 V	1.5 V	1.5 V	1.35 V	1.5 V	1.5 V		1.35 V 1.5 V
Max quantity*	12	12	12	12	12	12		12 12
Largest DIMM	4 GB	4 GB	4 GB	16 GB	16 GB	16 GB		16 GB 16 GB
Max memory capacity	48 GB	48 GB	48 GB	192 GB	192 GB	192 GB		192 GB 192 GB
Max memory at rated speed	48 GB	48 GB	48 GB	129 GB	192 GB	192 GB		N/A N/A
<b>Maximum operating speed (MHz)</b>								
1 DIMM per channel	1333 MHz	1333 MHz	1600 MHz	1333 MHz	1333 MHz	1600 MHz	800 MHz	800 MHz
2 DIMMs per channel	1333 MHz	1333 MHz	1600 MHz	1333 MHz	1333 MHz	1600 MHz	800 MHz	800 MHz

\* The maximum quantity supported is shown for two processors installed. When one processor is installed, the maximum quantity supported is half of that shown.

The following memory protection technologies are supported:

- ECC
- Chipkill (for x4-based memory DIMMs; look for "x4" in the DIMM description)
- Memory mirroring
- Memory sparing

If memory mirroring is used, then DIMMs must be installed in pairs (minimum of one pair per processor), and both DIMMs in a pair must be identical in type and size.

If memory rank sparing is used, then a minimum of one quad-rank DIMM or two single-rank or dual-rank DIMMs must be installed per populated channel (the DIMMs do not need to be identical). In rank sparing mode, one rank of a DIMM in each populated channel is reserved as spare memory. The size of a rank varies depending on the DIMMs installed.

The following table lists the memory options available for the x220 server. DIMMs can be installed one at a time, but for performance reasons, install them in sets of three (one for each of the three memory channels).

Table 6. Memory options for the x220

Part number	Feature code	Description	Models where used
Registered DIMMs (RDIMMs) - 1333 MHz and 1066 MHz			
49Y1406	8941	4 GB (1x 4 GB, 1Rx4, 1.35 V) PC3L-10600 CL9 ECC DDR3 1333 MHz LP RDIMM	J2x, L2x, DBx
49Y1407	8942	4 GB (1x 4 GB, 2Rx8, 1.35 V) PC3L-10600 CL9 ECC DDR3 1333 MHz LP RDIMM	C2x, D2x, F2x, G2x, G4x, H2x
49Y1397	8923	8 GB (1x 8 GB, 2Rx4, 1.35 V) PC3L-10600 CL9 ECC DDR3 1333 MHz LP RDIMM	-
49Y1563	A1QT	16 GB (1x16GB, 2Rx4, 1.35V) PC3L-10600 CL9 ECC DDR3 1333MHz LP RDIMM	-
49Y1400	8939	16 GB (1x 16 GB, 4Rx4, 1.35 V) PC3L-8500 CL7 ECC DDR3 1066 MHz LP RDIMM	-
Registered DIMMs (RDIMMs) - 1600 MHz			
49Y1559	A28Z	4 GB (1x4GB, 1Rx4, 1.5V) PC3-12800 CL11 ECC DDR3 1600MHz LP RDIMM	-
90Y3178	A24L	4 GB (1x4GB, 2Rx8, 1.5V) PC3-12800 CL11 ECC DDR3 1600MHz LP RDIMM	-
90Y3109	A292	8 GB (1x 8 GB, 2Rx4, 1.5 V) PC3-12800 CL11 ECC DDR3 1600 MHz LP RDIMM	-
00D4968	A2U5	16 GB (1x16GB, 2Rx4, 1.5V) PC3-12800 CL11 ECC DDR3 1600MHz LP RDIMM	-
Unbuffered DIMMs (UDIMMs)			
49Y1403	A0QS	2 GB (1x 2 GB, 1Rx8, 1.35 V) PC3L-10600 ECC DDR3 1333 MHz LP UDIMM	A2x, B2x
49Y1404	8648	4 GB (1x 4 GB, 2Rx8, 1.35 V) PC3L-10600 CL9 ECC DDR3 1333 MHz LP UDIMM	-
Load-reduced DIMMs (LRDIMMs)			
90Y3105	A291	32GB (1x32GB, 4Rx4, 1.35V) PC3L-10600 CL9 ECC DDR3 1333MHz LP LRDIMM	-

## RAID controllers for internal storage

The x220 server has two 2.5-inch hot-swap drive bays accessible from the front of the blade server (Figure 2). The server optionally supports 1.8-inch solid-state drives, as described later in this section.

The x220 supports three disk controllers:

- ServeRAID C105: An onboard SATA controller with software RAID capabilities
- ServeRAID H1135: An entry level hardware RAID controller
- ServeRAID M5115: An advanced RAID controller with cache, backup, and RAID options

These three controllers are mutually exclusive. The following table lists the ordering information.

Table 7. Internal storage controller ordering information

Part number	Feature code	Description	Maximum supported
Standard	None	ServeRAID C105	1
90Y4750	A1XJ	ServeRAID H1135 Controller for Flex System and BladeCenter®	1
90Y4390	A2XW	ServeRAID M5115 SAS/SATA Controller	1

### ServeRAID C105 controller

On standard models, the two 2.5-inch drive bays are connected to a ServeRAID C105 onboard SATA controller with software RAID capabilities. The C105 functionality is embedded in the Intel C600 chipset.

The C105 has the following features:

- Support for SATA drives (SAS is not supported)
- Support for RAID 0 and RAID 1 (non-RAID is not supported)
- 6 Gbps throughput per port
- Support for up to two volumes
- Support for virtual drive sizes greater than 2 TB
- Fixed stripe unit size of 64 KB
- Support for MegaRAID Storage Manager management software

**Note:** There is no native (in-box) driver for Windows and Linux; the drivers must be downloaded separately. There is no support for VMware, Hyper-V, Xen, or solid-state drives (SSD).

### **ServeRAID H1135**

The x220 also supports an entry level hardware RAID solution with the addition of the ServeRAID H1135 Controller for Flex System and BladeCenter. The H1135 is installed in a dedicated slot at the front of the server (see [Figure 3](#)). When the H1135 adapter is installed, the C105 controller is disabled.

The H1135 has the following features:

- Based on the LSI SAS2004 6 Gbps SAS 4-port controller
- PCIe 2.0 x4 host interface
- CIOv form factor (supported in the x220 and BladeCenter HS23E)
- Support for SAS, SATA, and SSD drives
- Support for RAID 0, RAID 1, and non-RAID
- 6 Gbps throughput per port
- Support for up to two volumes
- Fixed stripe size of 64 KB
- Native driver support in Windows, Linux, and VMware
- S.M.A.R.T. support
- Support for MegaRAID Storage Manager management software

### **ServeRAID M5115**

The ServeRAID M5115 SAS/SATA Controller (90Y4390) is an advanced RAID controller supporting RAID 0, 1, 10, 5, 50, and optional 6 and 60. It includes 1 GB of cache, which can be backed up to flash memory when attached to an optional supercapacitor. The M5115 attaches to the I/O adapter 1 connector and can be attached even if the Fabric Connector is installed (used to route the Embedded Gb Ethernet to chassis bays 1 and 2). The ServeRAID M5115 cannot be installed if an adapter is installed in I/O adapter slot 1. When the M5115 adapter is installed, the C105 controller is disabled.

The ServeRAID M5115 supports combinations of 2.5-inch drives and 1.8-inch solid-state drives:

- Up to two 2.5-inch drives only
- Up to two 2.5-inch drives, plus up to four 1.8-inch solid-state drives

We describe these configurations in the following section.

The ServeRAID M5115 controller has the following specifications:

- Eight internal 6 Gbps SAS/SATA ports.
- PCI Express 3.0 x8 host interface.
- 6 Gbps throughput per port.
- 800 MHz dual-core IBM PowerPC® processor with an LSI SAS2208 6 Gbps RAID on Chip (ROC) controller.

- Support for RAID levels 0, 1, 10, 5, 50 standard; support for RAID 6 and 60 with optional upgrade using 90Y4411.
- Onboard 1 GB data cache (DDR3 running at 1333 MHz) with optional flash backup (MegaRAID CacheVault technology) as part of the Enablement Kit 90Y4424.
- Support for SAS and SATA HDDs and SSDs.
- Support for intermixing SAS and SATA HDDs and SSDs. Mixing different types of drives in the same array (drive group) is not recommended.
- Support for self-encrypting drives (SEDs) with MegaRAID SafeStore.
- Optional support for SSD performance acceleration with MegaRAID FastPath and SSD caching with MegaRAID CacheCade Pro 2.0 (90Y4447).
- Support for up to 64 virtual drives, up to 128 drive groups, up to 16 virtual drives per one drive group, and up to 32 physical drives per one drive group.
- Support for logical unit number (LUN) sizes up to 64 TB.
- Configurable stripe size up to 1 MB.
- Compliant with Disk Data Format (DDF) configuration on disk (COD).
- S.M.A.R.T. support.
- MegaRAID Storage Manager management software.

### ServeRAID M5115 configurations and options

The x220 with the addition of the M5115 controller supports 2.5-inch drives or 1.8-inch solid-state drives or combinations of the two.

At least one hardware kit is required with the ServeRAID M5115 controller, and there are three hardware kits that are supported that enable specific drive support:

- ServeRAID M5100 Series Enablement Kit for Flex System x220 (90Y4424) enables support for up to two 2.5-inch HDDs or SSDs in the hot-swap bays in the front of the server. It includes a CacheVault unit, which enables MegaRAID CacheVault flash cache protection. This enablement kit replaces the standard two-bay backplane (which is attached through the planar to an onboard controller) with a new backplane that attaches to an included flex cable to the M5115 controller. It also includes an air baffle, which also serves as an attachment for the CacheVault unit.  
MegaRAID CacheVault flash cache protection uses NAND flash memory powered by a supercapacitor to protect data stored in the controller cache. This module eliminates the need for a lithium-ion battery commonly used to protect DRAM cache memory on PCI RAID controllers. To avoid the possibility of data loss or corruption during a power or server failure, CacheVault technology transfers the contents of the DRAM cache to NAND flash using power from the supercapacitor. After the power is restored to the RAID controller, the saved data is transferred from the NAND flash back to the DRAM cache, which can then be flushed to disk.
- ServeRAID M5100 Series SSD Expansion Kit for Flex System x220 (90Y4426) enables support for up to four internal 1.8-inch SSDs. This kit includes two air baffles, left and right, which can attach two 1.8-inch SSD attachment locations and flex cables for attachment to up to four 1.8-inch SSDs.

The following table shows the kits required for each combination of drives. For example, if you plan to install eight 1.8-inch SSDs, then you need the M5115 controller, the Flash kit, and the SSD Expansion kit.

Table 8. ServeRAID M5115 hardware kits

Desired drive support			Components required		
Maximum number of 2.5-inch drives	Maximum number of 1.8-inch SSDs		ServeRAID M5115 90Y4390	Enablement Kit 90Y4424	SSD Expansion Kit 90Y4426
2	0	=>	Required	Required	
2	4 (internal)	=>	Required	Required	Required

The following figure shows how the ServeRAID M5115 and the Enablement Kit are installed in the server to support two 2.5-inch drives with MegaRAID CacheVault flash cache protection (row 1 of the preceding table).

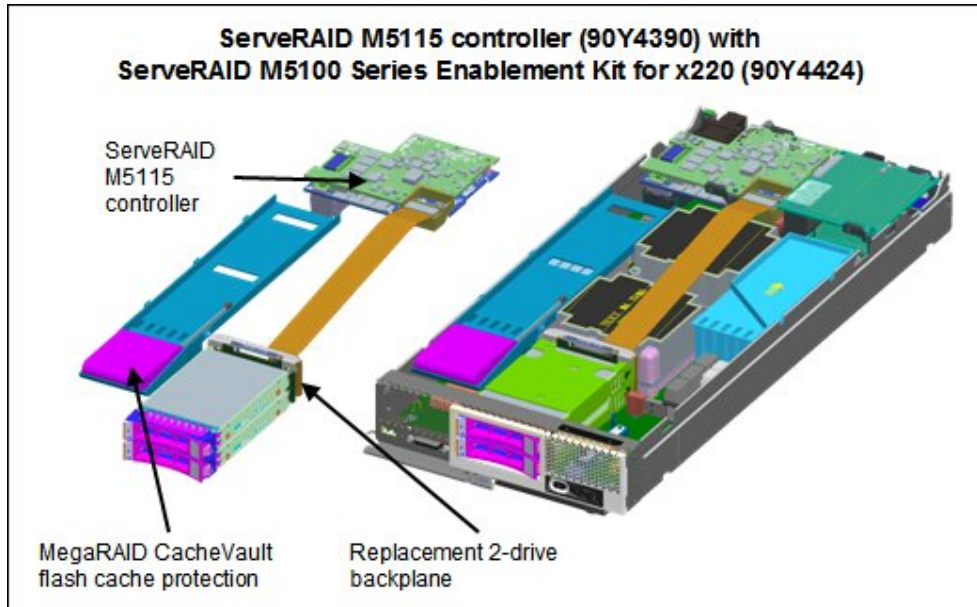

Figure 4. The ServeRAID M5115 and the Enablement Kit installed

For the configuration of two 2.5-inch drives, plus up to four 1.8-inch SSDs, the drives are installed in the following locations:

- Two 2.5 drives in the front of the system in the two 2.5-inch drive bays
- Two 1.8-inch SSDs in a tray above the memory banks for processor 1
- Two 1.8-inch SSDs in a tray above the memory banks for processor 2

Optional add-ons to the ServeRAID M5115 controller are RAID 6 support, SSD performance accelerator, and SSD caching enabler. The feature upgrades are as listed in the following table. These are all Lenovo Feature on Demand (FoD) license upgrades.

Table 9. Supported upgrade features

Part number	Feature code	Description	Maximum supported
90Y4410	A2Y1	ServeRAID M5100 Series RAID 6 Upgrade for Flex System	1
90Y4412	A2Y2	ServeRAID M5100 Series Performance Upgrade for Flex System (MegaRAID FastPath)	1
90Y4447	A36G	ServeRAID M5100 Series SSD Caching Enabler for Flex System (MegaRAID CacheCade Pro 2.0)	1

These features are described as follows:

- RAID 6 Upgrade (90Y4410)  
Adds support for RAID 6 and RAID 60. This is an FoD license.
- Performance Upgrade (90Y4412)  
The Performance Upgrade for Flex System (implemented using the LSI MegaRAID FastPath software) provides high-performance I/O acceleration for SSD-based virtual drives by using an extremely low-latency I/O path to increase the maximum I/O per second (IOPS) capability of the controller. This feature boosts the performance of applications with a highly random data storage access pattern, such as transactional databases. Part number 90Y4412 is an FoD license.
- SSD Caching Enabler for traditional hard drives (90Y4447)  
The SSD Caching Enabler for Flex System (implemented using the LSI MegaRAID CacheCade Pro 2.0) is designed to accelerate the performance of hard disk drive (HDD) arrays with only an incremental investment in solid-state drive (SSD) technology. The feature enables the SSDs to be configured as a dedicated cache to

help maximize the I/O performance for transaction-intensive applications, such as databases and web serving. The feature tracks data storage access patterns and identifies the most frequently accessed data. The hot data is then automatically stored on the SSDs that are assigned as a dedicated cache pool on the ServeRAID controller. Part number 90Y4447 is an FoD license. This feature requires that at least one SSD drive be installed.

**Note:** Not all SSDs support SSD Caching Enabler (CacheCade) feature. See <http://ibm.com/support/entry/portal/docdisplay?Indocid=MIGR-5094754> for details.

## Internal drive options

The 1.8-inch solid-state drives supported with the ServeRAID M5115 are listed in the following table.

Table 10. Supported 1.8-inch solid-state drives

Part number	Feature code	Description	Maximum supported
<b>1.8" 6 Gb Solid-state drives - Enterprise</b>			
00W1120	A3HQ	100GB SATA 1.8" MLC Enterprise SSD	4
49Y6119	A3AN	200GB SATA 1.8" MLC Enterprise SSD	4
49Y6124	A3AP	400GB SATA 1.8" MLC Enterprise SSD	4
41Y8366	A4FS	S3700 200GB SATA 1.8" MLC Enterprise SSD	4
41Y8371	A4FT	S3700 400GB SATA 1.8" MLC Enterprise SSD	4
<b>1.8" 6 Gb Solid-state drives - Enterprise value</b>			
00AJ040	A4KV	S3500 80GB SATA 1.8" MLC Enterprise Value SSD	4
00AJ045	A4KW	S3500 240GB SATA 1.8" MLC Enterprise Value SSD	4
00AJ050	A4KX	S3500 400GB SATA 1.8" MLC Enterprise Value SSD	4

The 2.5-inch drive bays support SAS or SATA hard disk drives (HDDs) or SATA solid-state drives (SSDs). The following table lists the supported 2.5-inch drive options. The maximum quantity supported is two.

Table 11. 2.5-inch drive options for internal disk storage

Part number	Feature code	Description	Supported by ServeRAID controller		
			C105	H1135	M5115
<b>2.5" 10K 6 Gb SAS hard disk drives</b>					
42D0637	5599	300GB 10K 6Gbps SAS 2.5" SFF Slim-HS HDD	No	Yes	Yes
49Y2003	5433	600GB 10K 6Gbps SAS 2.5" SFF Slim-HS HDD	No	Yes	Yes
81Y9650	A282	900GB 10K 6Gbps SAS 2.5" SFF HS HDD	No	Yes	Yes
90Y8877	A2XC	300GB 10K 6Gbps SAS 2.5" SFF G2HS HDD	No	Yes	Yes
90Y8872	A2XD	600GB 10K 6Gbps SAS 2.5" SFF G2HS HDD	No	Yes	Yes
00AD075	A48S	1.2TB 10K 6Gbps SAS 2.5" G2HS HDD	No	Yes	Yes
<b>2.5" 15K 6 Gb SAS hard disk drives</b>					
42D0677	5536	146GB 15K 6Gbps SAS 2.5" SFF Slim-HS HDD	No	Yes	Yes
81Y9670	A283	300GB 15K 6Gbps SAS 2.5" SFF HS HDD	No	Yes	Yes
90Y8926	A2XB	146GB 15K 6Gbps SAS 2.5" SFF G2HS HDD	No	Yes	Yes
00AJ300	A4VB	600GB 15K 6Gbps SAS 2.5" G2HS HDD	No	Yes	Yes
<b>2.5" 10K 6 Gb Self-encrypting drives (SEDs)</b>					
90Y8913	A2XF	300GB 10K 6Gbps SAS 2.5" SFF G2HS SED	No	Yes	Yes
90Y8908	A3EF	600GB 10K 6Gbps SAS 2.5" SFF G2HS SED	No	Yes	Yes
81Y9662	A3EG	900GB 10K 6Gbps SAS 2.5" SFF G2HS SED	No	Yes	Yes

Part number	Feature code	Description	Supported by ServeRAID controller		
			C105	H1135	M5115
00AD085	A48T	1.2TB 10K 6Gbps SAS 2.5" G2HS SED	No	Yes	Yes
<b>2.5" 15K 6 Gb Self-encrypting drives (SEDs)</b>					
90Y8944	A2ZK	146GB 15K 6Gbps SAS 2.5" SFF G2HS SED	No	Yes	Yes
<b>2.5" 6 Gb SAS-SSD hybrid drives</b>					
00AD102	A4G7	600GB 10K 6Gbps SAS 2.5" G2HS Hybrid	No	Yes	Yes
<b>2.5" 6 Gb NL SAS hard disk drives</b>					
42D0707	5409	500GB 7200 6Gbps NL SAS 2.5" SFF Slim-HS HDD	No	Yes	Yes
81Y9690	A1P3	1TB 7.2K 6Gbps NL SAS 2.5" SFF HS HDD	No	Yes	Yes
90Y8953	A2XE	500GB 7.2K 6Gbps NL SAS 2.5" SFF G2HS HDD	No	Yes	Yes
<b>2.5" 6 Gb NL SATA hard disk drives</b>					
81Y9722	A1NX	250GB 7.2K 6Gbps NL SATA 2.5" SFF HS HDD	Yes	Yes	Yes
81Y9726	A1NZ	500GB 7.2K 6Gbps NL SATA 2.5" SFF HS HDD	Yes	Yes	Yes
81Y9730	A1AV	1TB 7.2K 6Gbps NL SATA 2.5" SFF HS HDD	Yes	Yes	Yes
<b>2.5" 6 Gb SATA Solid-state drives - Enterprise</b>					
41Y8331	A4FL	S3700 200GB SATA 2.5" MLC HS Enterprise SSD	No	Yes	Yes
41Y8336	A4FN	S3700 400GB SATA 2.5" MLC HS Enterprise SSD	No	Yes	Yes
41Y8341	A4FQ	S3700 800GB SATA 2.5" MLC HS Enterprise SSD	No	Yes	Yes
<b>2.5" 6 Gb SAS Solid-state drives - Enterprise</b>					
43W7718	A2FN	200GB SATA 2.5" MLC HS SSD	No	Yes	Yes
00W1125	A3HR	100GB SATA 2.5" MLC HS Enterprise SSD	No	Yes	Yes
49Y6134	A3EY	400GB SAS 2.5" MLC HS Enterprise SSD	No	Yes	Yes
49Y6139	A3F0	800GB SAS 2.5" MLC HS Enterprise SSD	No	Yes	Yes
49Y6195	A4GH	1.6TB SAS 2.5" MLC HS Enterprise SSD	No	Yes	Yes
<b>2.5" 6 Gb Solid-state drives - Enterprise value</b>					
00AJ000	A4KM	S3500 120GB SATA 2.5" MLC HS Enterprise Value SSD	No	Yes	Yes
00AJ005	A4KN	S3500 240GB SATA 2.5" MLC HS Enterprise Value SSD	No	Yes	Yes
00AJ010	A4KP	S3500 480GB SATA 2.5" MLC HS Enterprise Value SSD	No	Yes	Yes
00AJ015	A4KQ	S3500 800GB SATA 2.5" MLC HS Enterprise Value SSD	No	Yes	Yes
00FN268	A5U4	S3500 1.6TB SATA 2.5" MLC HS Enterprise Value SSD	No	Yes	Yes
49Y5844	A3AU	512GB SATA 2.5" MLC HS Enterprise Value SSD	No	Yes	Yes
00AJ355	A56Z	120GB SATA 2.5" MLC HS Enterprise Value SSD	No	Yes	Yes
00AJ360	A570	240GB SATA 2.5" MLC HS Enterprise Value SSD	No	Yes	Yes
00AJ365	A571	480GB SATA 2.5" MLC HS Enterprise Value SSD	No	Yes	Yes
00AJ370	A572	800GB SATA 2.5" MLC HS Enterprise Value SSD	No	Yes	Yes



## Flex System Storage Expansion Node

The x220 supports the attachment of the Flex System Storage Expansion Node. The Flex System Storage Expansion Node provides the ability to attach additional 12 hot-swap 2.5-inch HDDs or SSDs locally to the attached compute node. The Storage Expansion Node provides storage capacity for Network Attach Storage (NAS) workloads, providing flexible storage to match capacity, performance and reliability needs.

Model 7906-DBx includes the Storage Expansion Node as standard as listed in [Table 2](#). All other models support the SEN as an option.

The following figure shows the Flex System Storage Expansion Node attached to a compute node.



Figure 5. Flex System Storage Expansion Node (right) attached to a compute node (left)

The ordering information for the Storage Expansion Node is shown in the following table.

Table 12. Ordering part number and feature code

Part number	Feature code	Description	Maximum supported
68Y8588	A3JF	Flex System Storage Expansion Node	1

The Storage Expansion Node has the following features:

- Connects directly to supported compute nodes via a PCIe 3.0 interface to the compute node's expansion connector (See Figure 3)
- Support for 12 hot-swap 2.5-inch drive, accessible via a sliding tray
- Support for 6 Gbps SAS and SATA drives, both HDDs and SSDs
- Based on an LSI SAS2208 6 Gbps RAID on Chip (ROC) controller
- Supports RAID 0, 1, 5, 10, and 50 as standard. JBOD also supported. Optional RAID 6 and 60 with an FoD upgrade.
- Optional 512 MB or 1 GB cache with cache-to-flash super capacitor offload

**Note:** The use of the Storage Expansion Node requires that the x220 Compute Node have both processors installed.

For more information, see the Product Guide on the Flex System Storage Expansion Node, <http://www.redbooks.ibm.com/abstracts/tips0914.html?Open>

## Internal tape drives

The server does not support an internal tape drive. However, it can be attached to external tape drives using Fibre Channel connectivity.

## Optical drives

The server does not support an internal optical drive option, however, you can connect an external USB optical drive. See <http://support.lenovo.com/en/documents/pd011281> for information about available external optical drives from Lenovo. Alternatively, use the remote media feature of the IMMv2 and the Chassis Management Module. (Ask dw: Last line applies to Flex Sys only?)

**Note:** The USB port on the compute nodes supply up to 0.5 A at 5 V. For devices that require more power, an additional power source will be required.

## Embedded 1 Gb Ethernet controller

Some models of the x220 include an Embedded 1 Gb Ethernet controller (also known as LAN on Motherboard or LOM) built into the system board. [Table 2](#) lists what models of the x220 include the controller. Each x220 model that includes the controller also has the Compute Node Fabric Connector installed in I/O connector 1 (and physically screwed onto the system board) to provide connectivity to the Enterprise Chassis midplane. [Figure 3](#) shows the location of the Fabric Connector.

The Fabric Connector enables port 1 on the controller to be routed to I/O module bay 1 and port 2 to be routed to I/O module bay 2. The Fabric Connector can be unscrewed and removed, if required, to allow the installation of an I/O adapter on I/O connector 1.

The Embedded 1 Gb Ethernet controller has the following features:

- Broadcom BCM5718 based
- Dual-port Gigabit Ethernet controller
- PCIe 2.0 x2 host bus interface
- Supports Wake on LAN
- Supports Serial over LAN
- Supports IPv6

**Note:** TCP/IP Offload Engine (TOE) is not supported.

## I/O expansion options

The x220 has two I/O expansion connectors for attaching I/O adapter cards. There is a third expansion connector designed to connect an expansion node such as the PCIe Expansion Node. The I/O expansion connectors are a very high-density 216-pin PCIe connector. Installing I/O adapter cards allows the server to connect with switch modules in the Flex System Enterprise Chassis. Each slot has one PCI Express 3.0 x8 and one PCI Express x4 interface and both slots support the same form-factor adapters.

The following figure shows the location of the I/O expansion connectors.

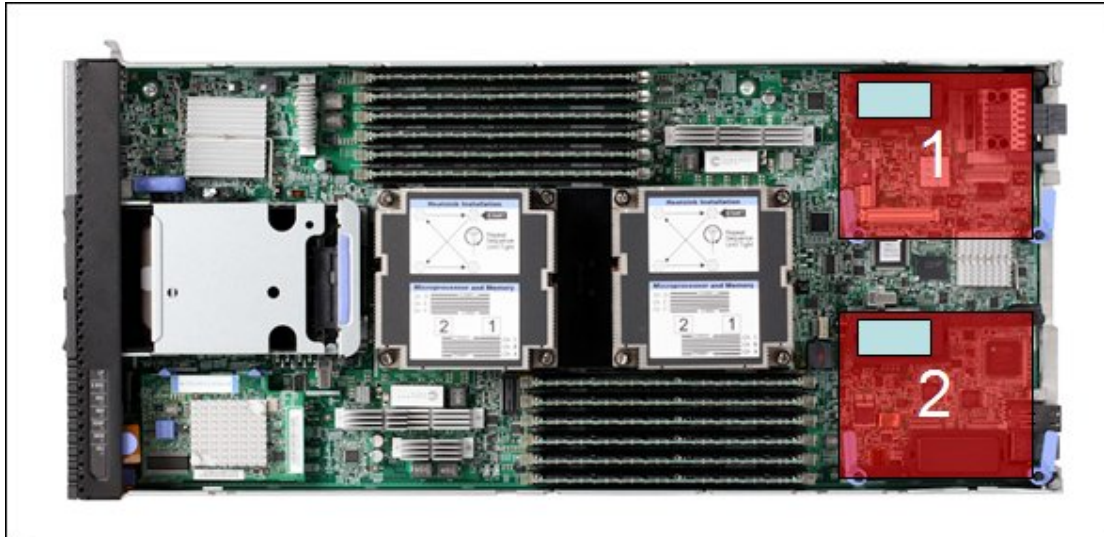

Figure 6. Location of the I/O adapter slots in the Flex System x220 Compute Node

All I/O adapters are the same shape and can be used in any available slot.. A compatible switch or pass-through module must be installed in the corresponding I/O bays in the chassis, as indicated in the following table. Installing two switches means that all ports of the adapter are enabled, which improves performance and network availability.

Table 13. Adapter to I/O bay correspondence

I/O adapter slot in the server	Port on the adapter	Corresponding I/O module bay in the chassis
Slot 1	Port 1	Module bay 1
	Port 2	Module bay 2
	Port 3 (for 4-port cards)	Module bay 1
	Port 4 (for 4-port cards)	Module bay 2
Slot 2	Port 1	Module bay 3
	Port 2	Module bay 4
	Port 3 (for 4-port cards)	Module bay 3
	Port 4 (for 4-port cards)	Module bay 4

The following figure shows the location of the switch bays in the Flex System Enterprise Chassis.

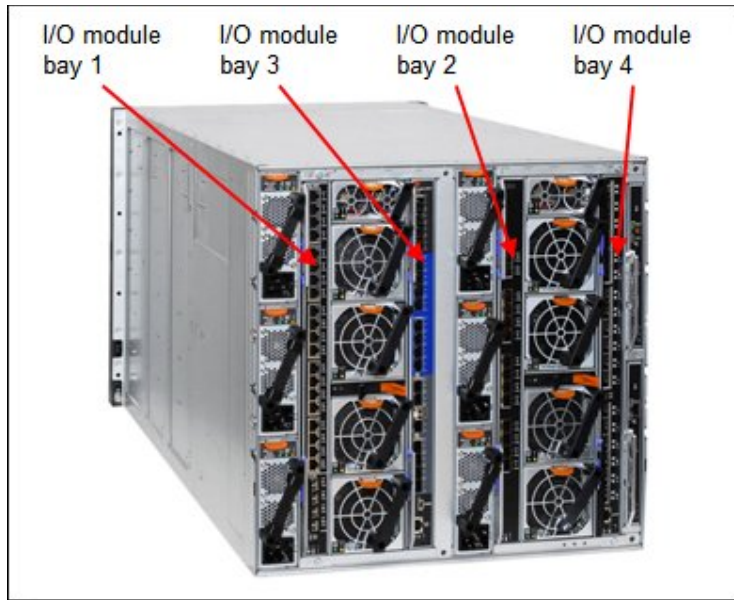

Figure 7. Location of the switch bays in the Flex System Enterprise Chassis

The following figure shows how two-port adapters are connected to switches installed in the chassis.

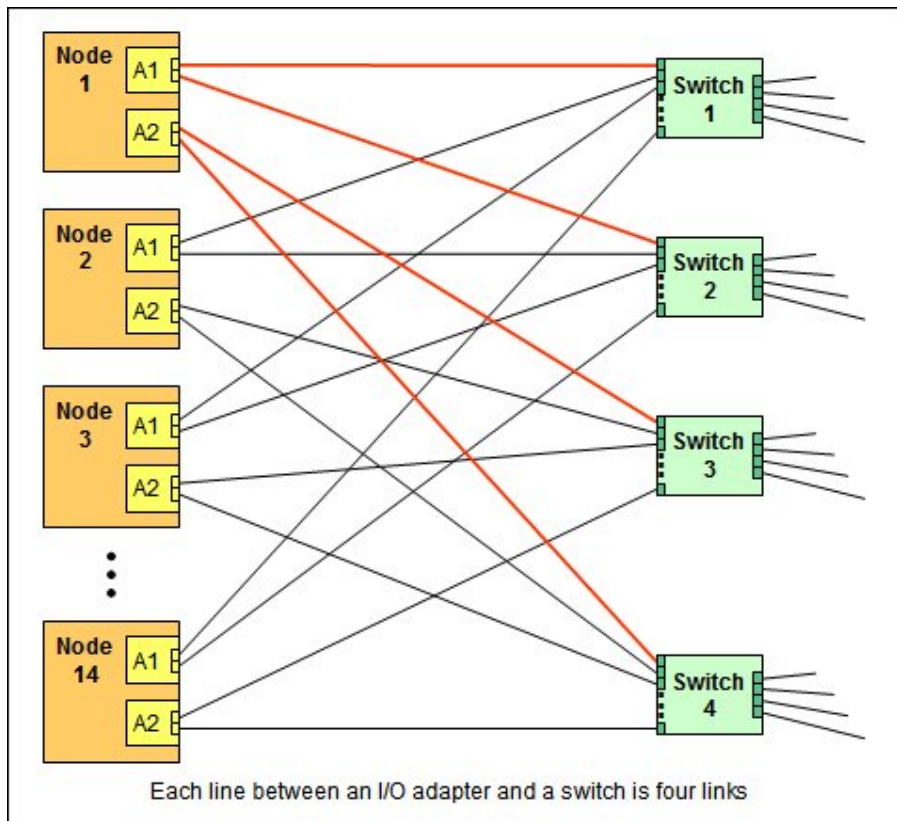

Figure 8. Logical layout of the interconnects between I/O adapters and I/O modules

## Flex System PCIe Expansion Node

The x220 supports the attachment of the Flex System PCIe Expansion Node. The Flex System PCIe Expansion Node provides the ability to attach additional PCI Express cards such as High IOPS SSD adapters, fabric mezzanine cards, and next-generation graphics processing units (GPU) to supported Flex System compute nodes. This capability is ideal for many applications that require high performance I/O, special telecommunications network interfaces, or hardware acceleration using a PCI Express card. The PCIe Expansion Node supports up to four PCIe 2.0 adapters and two additional Flex System expansion adapters.

The PCIe Expansion Node is attached to the x220 as shown in the following figure.

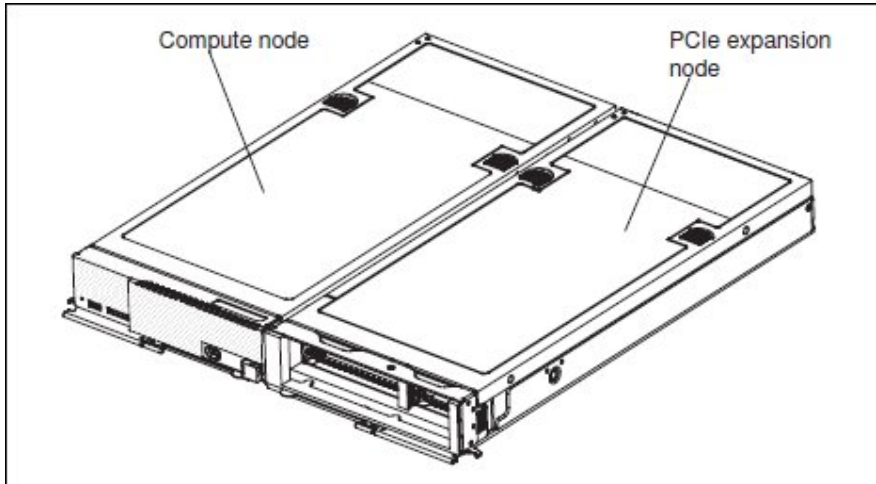

Figure 9. PCIe Expansion Node

The ordering information for the PCIe Expansion Node is shown in the following table.

Table 14. Ordering part number and feature code

Part number	Feature code	Description	Maximum supported
81Y8983	A1BV	Flex System PCIe Expansion Node	1

The PCIe Expansion Node has the following features:

- Support for up to four standard PCIe 2.0 adapters:
  - Two PCIe 2.0 x16 slots that support full-length, full-height adapters
  - Two PCIe 2.0 x8 slots that support half-length, low-profile adapters
- Support for PCIe 3.0 adapters by operating them in PCIe 2.0 mode
- Support for one full-length, full-height double-wide adapter (consuming the space of the two full-length, full-height adapter slots)
- Support for PCIe cards with higher power requirements -- a single adapter card (up to 225W), or to two adapters (up to 150W each)
- Two Flex System I/O expansion connectors for to further expand the I/O capability of the attached compute node.

**Note:** The use of the PCIe Expansion Node requires that the x220 Compute Node have both processors installed.

For more information, see the Product Guide on the Flex System PCIe Expansion Node, <http://www.redbooks.ibm.com/abstracts/tips0906.html?Open>

## Network adapters

As described in "Embedded 1 Gb Ethernet Adapter," certain models have a Embedded 1 Gb Ethernet controller on the system board, and its ports are routed to the midplane and switches installed in the chassis through a Compute Node Fabric Connector that takes the place of an adapter in I/O slot 1.

Models without the Embedded 1 Gb Ethernet controller do not include any other Ethernet connections to the Enterprise Chassis midplane as standard. Therefore, for those models, an I/O adapter must be installed in either I/O connector 1 or I/O connector 2 to provide network connectivity between the server and the chassis midplane and ultimately to the network switches.

The following table lists the supported network adapters and upgrades. Adapters can be installed in either slot. However, compatible switches must be installed in the corresponding bays of the chassis. All adapters can also be installed in the PCIe Expansion Node.

Table 15. Network adapters

Part number	Feature code	Description	Number of ports	Maximum supported*
<b>40 Gb Ethernet</b>				
90Y3482	A3HK	Flex System EN6132 2-port 40Gb Ethernet Adapter	2	2
<b>10 Gb Ethernet</b>				
90Y3554	A1R1	Flex System CN4054 10 Gb Virtual Fabric Adapter	4	2
90Y3558	A1R0	Flex System CN4054 Virtual Fabric Adapter (SW Upgrade) (FoD to provide FCoE and iSCSI support) (one license required per adapter)	License	2
90Y3466	A1QY	Flex System EN4132 2-port 10 Gb Ethernet Adapter	2	2
<b>1 Gb Ethernet</b>				
49Y7900	A10Y	Flex System EN2024 4-port 1 Gb Ethernet Adapter	4	2
<b>InfiniBand</b>				
90Y3454	A1QZ	Flex System IB6132 2-port FDR InfiniBand Adapter	2	2

\* For models with the Embedded 1 Gb Ethernet controller standard, the Compute Node Fabric Connector occupies the same space as an I/O adapter in I/O slot 1, so you have to remove the Fabric Connector if you plan to install an adapter in I/O slot 1.

For adapter-to-switch compatibility, see the Flex System Interoperability Guide:  
<http://www.redbooks.ibm.com/fsig>

For more information, see the list of Product Guides in the Adapter cards category:  
<http://www.redbooks.ibm.com/portals/puresystems?Open&page=pg&cat=adapters>

## Storage host bus adapters

The following table lists storage HBAs supported by the x220 server. Adapters can be installed in either slot. However, compatible switches must be installed in the corresponding bays of the chassis. All adapters can also be installed in the PCIe Expansion Node.

Table 16. Storage adapters

Part number	Feature code	Description	Number of ports	Maximum supported*
Fibre Channel				
88Y6370	A1BP	Flex System FC5022 2-port 16 Gb FC Adapter	2	2
69Y1938	A1BM	Flex System FC3172 2-port 8 Gb FC Adapter	2	2
95Y2375	A2N5	Flex System FC3052 2-port 8 Gb FC Adapter	2	2
95Y2386	A45R	Flex System FC5052 2-port 16Gb FC Adapter	2	2
95Y2391	A45S	Flex System FC5054 4-port 16Gb FC Adapter	4	2
69Y1942	A1BQ	Flex System FC5172 2-port 16Gb FC Adapter	2	2

\* For models with the Embedded 1 Gb Ethernet controller standard, the Compute Node Fabric Connector occupies the same space as an I/O adapter in I/O slot 1, so you have to remove the Fabric Connector if you plan to install an adapter in I/O slot 1.

For more information, see the list of Product Guides in the Adapter cards category:  
<http://www.redbooks.ibm.com/portals/puresystems?Open&page=pg&cat=adapters>

## PCIe SSD adapters

The compute node supports the High IOPS SSD adapters listed in the following table.

**Note:** These adapters are installed in an attached PCIe Expansion Node.

Table 17. SSD adapters

Part number	Feature code	Description	Maximum supported
46C9078	A3J3	365GB High IOPS MLC Mono Adapter (low-profile adapter)	4
46C9081	A3J4	785GB High IOPS MLC Mono Adapter (low-profile adapter)	4
81Y4519*	5985	640GB High IOPS MLC Duo Adapter (full-height adapter)	2
81Y4527*	A1NB	1.28TB High IOPS MLC Duo Adapter (full-height adapter)	2
90Y4377	A3DY	1.2TB High IOPS MLC Mono Adapter (low-profile adapter)	4
90Y4397	A3DZ	2.4TB High IOPS MLC Duo Adapter (full-height adapter)	2

\* Withdrawn from marketing

For information about the High IOPS adapters, the following Product Guides:

- High IOPS MLC Adapters  
<http://www.redbooks.ibm.com/abstracts/tips0907.html>
- High IOPS Modular Adapters  
<http://www.redbooks.ibm.com/abstracts/tips0937.html>
- High IOPS SSD PCIe Adapters  
<http://www.redbooks.ibm.com/abstracts/tips0729.html>

## GPU adapters

The compute node supports the GPU adapters listed in the following table.

**Note:** These adapters are installed in an attached PCIe Expansion Node.

Table 18. GPU adapters

Part number	Feature code	Description	Maximum supported
94Y5960	A1R4	NVIDIA Tesla M2090 (full-height adapter)	1*
47C2120	A4F1	NVIDIA GRID K1 for Flex System PCIe Expansion Node	1†
47C2121	A4F2	NVIDIA GRID K2 for Flex System PCIe Expansion Node	1†
47C2119	A4F3	NVIDIA Tesla K20 for Flex System PCIe Expansion Node	1†
47C2137	A5HD	NVIDIA Tesla K40 for Flex System PCIe Expansion Node	1†
47C2122	A4F4	Intel Xeon Phi 5110P for Flex System PCIe Expansion Node	1†

\* When this double-wide adapter is installed in the PCIe Expansion Node, it occupies both full-height slots. The low-profile slots and Flex System I/O expansion slots can still be used.

† If installed, only this adapter is supported in the system. No other PCIe adapters may be installed.

\*\* Orderable as separate MTM 4765-001 feature 4809. Available via AAS (e-config) only.

## Power supplies

Server power is derived from the power supplies installed in the chassis. There are no server options regarding power supplies.



## Integrated virtualization

The x220 supports the ESXi hypervisor on a USB memory key via two internal USB ports (see [Figure 3](#)). The supported USB memory keys are listed in the following table.

There are two types of USB keys, preloaded keys or blank keys. Blank keys allow you to download a Lenovo customized version of ESXi and load it onto the key. The x220 supports one or two keys installed, but only certain combinations:

Supported combinations:

- One preload key
- One blank key
- One preload key and one blank key
- Two blank keys

Unsupported combinations:

- Two preload keys

Installing two preloaded keys will prevent ESXi from booting as described in <http://kb.vmware.com/kb/1035107>. Having two keys installed provides a backup boot device. both devices are listed in the boot menu, which allows you to boot from either device or to set one as a backup in case the first one gets corrupted.

Table 19. Virtualization options

Part number	Feature code	Description	Maximum supported
41Y8298	A2G0	Blank USB Memory Key for VMware ESXi Downloads	2
41Y8300	A2VC	USB Memory Key for VMware ESXi 5.0	1
41Y8307	A383	USB Memory Key for VMware ESXi 5.0 Update1	1
41Y8311	A2R3	USB Memory Key for VMWare ESXi 5.1	1
41Y8382	A4WZ	USB Memory Key for VMware ESXi 5.1 Update 1	1
41Y8385	A584	USB Memory Key for VMware ESXi 5.5	1

**Note:** VMware is not supported with the ServeRAID C105 disk controller (Software RAID), but is supported with the use of ServeRAID H1135 controller (part number 90Y4750) or ServeRAID M5115 controller (part number 90Y4390).

## Light path diagnostics

For quick problem determination when you are physically at the server, the x220 offers a three-step guided path:

1. The Fault LED on the front panel
2. The light path diagnostics panel, shown in the following figure.
3. LEDs next to key components on the system board

The x220 light path diagnostics panel is visible when you remove the server from the chassis. The panel is located at the upper right side of the compute node, as shown in the following figure.

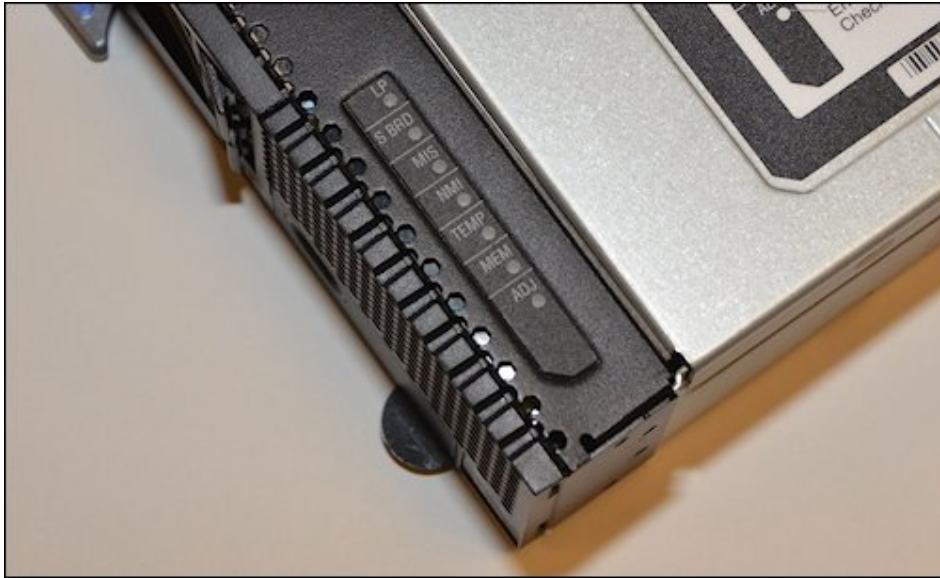

Figure 10. Location of x220 light path diagnostics panel

To illuminate the light path diagnostics LEDs, power off the compute node, slide it out of the chassis, and press the power button. The power button doubles as the light path diagnostics remind button when the server is removed from the chassis.

The meanings of the LEDs in the light path diagnostics panel are listed in the following table.

Table 20. Light path diagnostic panel LEDs

LED	Meaning
LP	The light path diagnostics panel is operational.
S BRD	A system board error is detected.
MIS	A mismatch has occurred between the processors, DIMMs, or HDDs within the configuration (as reported by POST).
NMI	A non-maskable interrupt (NMI) has occurred.
TEMP	An over-temperature condition occurs that was critical enough to shut down the server.
MEM	A memory fault has occurred. The corresponding DIMM error LEDs on the system board are also lit.
ADJ	A fault is detected in the adjacent expansion unit (if installed).

## Remote management

The server contains an Integrated Management Module II (IMM2), which interfaces with the advanced management module in the chassis. The combination of these features provides advanced service-processor control, monitoring, and an alerting function. If an environmental condition exceeds a threshold or if a system component fails, LEDs on the system board are lit to help you diagnose the problem, the error is recorded in the event log, and you are alerted to the problem. A virtual presence capability comes standard for remote server management.

Remote server management is provided through industry-standard interfaces:

- Intelligent Platform Management Interface (IPMI) Version 2.0
- Simple Network Management Protocol (SNMP) Version 3
- Common Information Model (CIM)
- Web browser

The server also supports virtual media and remote control features, which provide the following functions:

- Remotely viewing video with graphics resolutions up to 1600x1200 at 75 Hz with up to 23 bits per pixel, regardless of the system state
- Remotely accessing the server using the keyboard and mouse from a remote client
- Mapping the CD or DVD drive, diskette drive, and USB flash drive on a remote client, and mapping ISO and diskette image files as virtual drives that are available for use by the server
- Uploading a diskette image to the IMM2 memory and mapping it to the server as a virtual drive
- Capturing blue-screen errors

## Supported operating systems

The server supports the following operating systems:

- Microsoft Windows Server 2008 HPC Edition
- Microsoft Windows Server 2008 R2
- Microsoft Windows Server 2008, Datacenter x64 Edition
- Microsoft Windows Server 2008, Enterprise x64 Edition
- Microsoft Windows Server 2008, Standard x64 Edition
- Microsoft Windows Server 2008, Web x64 Edition
- Microsoft Windows Server 2012
- Red Hat Enterprise Linux 5 Server with Xen x64 Edition
- Red Hat Enterprise Linux 5 Server x64 Edition
- Red Hat Enterprise Linux 6 Server x64 Edition
- SUSE LINUX Enterprise Server 10 for AMD64/EM64T
- SUSE LINUX Enterprise Server 11 for AMD64/EM64T
- SUSE LINUX Enterprise Server 11 with Xen for AMD64/EM64T
- VMware ESX 4.1
- VMware ESXi 4.1
- VMware vSphere 5.0 (ESXi)
- VMware vSphere 5.1 (ESXi)

**Note:** There is no native (in-box) driver for the ServeRAID C105 controller for Windows and Linux; the drivers must be downloaded separately. The ServeRAID C105 controller does not support for VMware, Hyper-V, Xen, or solid-state drives (SSD).

Check the Lenovo Operating System Interoperability Guide for the latest information about the specific versions and service levels supported and any other prerequisites.

<http://lenovopress.com/osig>

## Physical specifications

Dimensions and weight (approximate):

- Width: 217 mm (8.6 in.)
- Height: 56 mm (2.2 in.)
- Depth: 492 mm (19.4 in.)
- Maximum weight: 6.4 kg (14.11 lb)

Shipping dimensions and weight (approximate):

- Height: 197 mm (7.8 in.)
- Depth: 603 mm (23.7 in.)
- Width: 430 mm (16.9 in.)
- Weight: 8 kg (17.6 lb)

## Supported environment

The Flex System x220 compute node complies with ASHRAE Class A3 specifications.

This is the supported operating environment:

Power on:

- Temperature: 5 - 40 °C (41 - 104 °F)
- Humidity, non-condensing: -12 °C dew point (10.4 °F) and 8 - 85% relative humidity
- Maximum dew point: 24 °C (75 °F)
- Maximum altitude: 3048 m (10,000 ft)
- Maximum rate of temperature change: 5 °C/hr (41 °F/hr)

Power off:

- Temperature: 5 - 45 °C (41 - 113 °F)
- Relative humidity: 8 - 85%
- Maximum dew point: 27 °C (80.6 °F)

Storage (non-operating):

- Temperature: 1 - 60 °C (33.8 - 140 °F)
- Altitude: 3050 m (10,006 ft)
- Relative humidity: 5 - 80%
- Maximum dew point: 29 °C (84.2°F)

Shipment (non-operating):

- Temperature: -40 - 60 °C (-40 - 140 °F)
- Altitude: 10,700 m (35,105 ft)
- Relative humidity: 5 - 100%
- Maximum dew point: 29 °C (84.2 °F)

## Warranty options

The system has a three-year warranty with 24x7 standard call center support and 9x5 Next Business Day onsite coverage. Also available are Lenovo Services warranty maintenance upgrades and post-warranty maintenance agreements, with a well-defined scope of services, including service hours, response time, term of service, and service agreement terms and conditions.

Lenovo warranty service upgrade offerings are country-specific. Not all warranty service upgrades are available in every country. For more information about Lenovo warranty service upgrade offerings that are available in your country, go to the Data Center Advisor and Configurator (formerly known as LESC) website <http://lesc.lenovo.com>, then do the following:

1. In the Customize a Model box in the middle of the page, select the **Services** option in the Customization Option dropdown menu
2. Enter in the machine type & model of the system
3. From the search results, you can click either **Deployment Services** or **Support Services** to view the offerings

The following table explains warranty service definitions in more detail.

Table 21. Warranty service definitions

Term	Description
On-site service	A service technician will arrive at the client's location for equipment service.
24x7x2 hour	A service technician is scheduled to arrive at the client's location within two hours after remote problem determination is completed. Lenovo provides service around the clock, every day, including Lenovo holidays.
24x7x4 hour	A service technician is scheduled to arrive at the client's location within four hours after remote problem determination is completed. Lenovo provides service around the clock, every day, including Lenovo holidays.
9x5x4 hour	A service technician is scheduled to arrive at the client's location within four business hours after remote problem determination is completed. Lenovo provides service 8:00 am - 5:00 pm in the client's local time zone, Monday-Friday, excluding Lenovo holidays. For example, if a customer reports an incident at 3:00 pm on Friday, the technician will arrive by 10:00 am the following Monday.
9x5 next business day	A service technician is scheduled to arrive at the client's location on the business day after remote problem determination is completed. Lenovo provides service 8:00 am - 5:00 pm in the client's local time zone, Monday - Friday, excluding Lenovo holidays. Calls received after 4:00 pm local time require an extra business day for service dispatch. Next business day service is not guaranteed.
Committed Repair	Problems receive priority handling so that repairs are completed within the committed time of 6, 8, or 24 hours. Lenovo provides service 24 hours/day, every day, including Lenovo holidays.

The following Lenovo warranty service upgrades are available:

- Warranty and maintenance service upgrades:
  - Three, four, or five years of 9x5 or 24x7 service coverage
  - Onsite response from next business day to 2 or 4 hours
  - Committed repair service
  - Warranty extension of up to 5 years
  - Post warranty extensions
- Committed Repair Service
 

Committed Repair Services enhances the level of Warranty Service Upgrade or Post Warranty/Maintenance Service offering associated with the selected systems. Offerings vary and are available in select countries.

  - Priority handling to meet defined time frames to restore the failing machine to good working condition
  - Committed repair service levels are measured within the following coverage hours:
    - 24x7x6: Service performed 24 hours per day, 7 days per week, within 6 hours
    - 24x7x8: Service performed 24 hours per day, 7 days per week, within 8 hours
    - 24x7x24: Service performed 24 hours per day, 7 days per week, within 24 hours
- Hard Disk Drive Retention
 

Lenovo's Hard Disk Drive Retention (HDDR) service is a multi-drive hard drive retention offering that ensures your data is always under your control, regardless of the number of hard drives that are installed in your Lenovo server. In the unlikely event of a hard drive failure, you retain possession of your hard drive while Lenovo replaces the failed drive part. Your data stays safely on your premises, in your hands. The Hard Drive Retention service can be purchased in convenient bundles with our warranty upgrades and extensions.

- **Microcode Support**  
Keeping microcode current helps prevent hardware failures and security exposure. There are two levels of service: analysis of the installed base and analysis and update where required. Offerings vary by country and can be bundled with other warranty upgrades and extensions.
- **Remote Technical Support Services (RTS)**  
RTS provides comprehensive technical call center support for covered servers, storage, operating systems, and applications. Providing a single source for support of hardware and software issues, RTS can reduce problem resolution time, decreasing the cost to address technical problems and increasing uptime. Offerings are available for Windows, Linux, IBM Systems Director, VMware, Microsoft business applications, and Lenovo System x storage devices, and IBM OEM storage devices.

## Regulatory compliance

The server conforms to the following standards:

- ASHRAE Class A3
- FCC - Verified to comply with Part 15 of the FCC Rules Class A
- Canada ICES-004, issue 3 Class A
- UL/IEC 60950-1
- CSA C22.2 No. 60950-1
- NOM-019
- Argentina IEC 60950-1
- Japan VCCI, Class A
- IEC 60950-1 (CB Certificate and CB Test Report)
- China CCC (GB4943); (GB9254, Class A); (GB17625.1)
- Taiwan BSMI CNS13438, Class A; CNS14336
- Australia/New Zealand AS/NZS CISPR 22, Class A
- Korea KN22, Class A, KN24
- Russia/GOST ME01, IEC 60950-1, GOST R 51318.22, GOST R 51318.249, GOST R 51317.3.2, GOST R 51317.3.3
- IEC 60950-1 (CB Certificate and CB Test Report)
- CE Mark (EN55022 Class A, EN60950-1, EN55024, EN61000-3-2, and EN61000-3-3)
- CISPR 22, Class A
- TUV-GS (EN60950-1/IEC 60950-1, EK1-ITB2000)

## Related publications and links

For more information, see the following resources:

- US Product Announcement:  
<http://ibm.com/common/ssi/cgi-bin/ssialias?infotype=dd&subtype=ca&&htmlfid=897/ENUS112-096>
- Flex System Information Center:  
<http://publib.boulder.ibm.com/infocenter/flexsys/information/index.jsp>
- *Flex System x220 Compute Node Installation and Service Guide* :  
[http://publib.boulder.ibm.com/infocenter/flexsys/information/topic/com.ibm.acc.7906.doc/printable\\_doc.html](http://publib.boulder.ibm.com/infocenter/flexsys/information/topic/com.ibm.acc.7906.doc/printable_doc.html)
- ServerProven for Flex System:  
<http://www.lenovo.com/us/en/serverproven/flexsystem.shtml>
- Operating System Interoperability Guide:  
<http://lenovopress.com/osig>
- *Flex System Interoperability Guide* :

<http://www.redbooks.ibm.com/fsig>

## **Related product families**

Product families related to this document are the following:

- [Blade Servers](#)

## Notices

Lenovo may not offer the products, services, or features discussed in this document in all countries. Consult your local Lenovo representative for information on the products and services currently available in your area. Any reference to a Lenovo product, program, or service is not intended to state or imply that only that Lenovo product, program, or service may be used. Any functionally equivalent product, program, or service that does not infringe any Lenovo intellectual property right may be used instead. However, it is the user's responsibility to evaluate and verify the operation of any other product, program, or service. Lenovo may have patents or pending patent applications covering subject matter described in this document. The furnishing of this document does not give you any license to these patents. You can send license inquiries, in writing, to:

Lenovo (United States), Inc.  
1009 Think Place - Building One  
Morrisville, NC 27560  
U.S.A.  
Attention: Lenovo Director of Licensing

LENOVO PROVIDES THIS PUBLICATION "AS IS" WITHOUT WARRANTY OF ANY KIND, EITHER EXPRESS OR IMPLIED, INCLUDING, BUT NOT LIMITED TO, THE IMPLIED WARRANTIES OF NON-INFRINGEMENT, MERCHANTABILITY OR FITNESS FOR A PARTICULAR PURPOSE. Some jurisdictions do not allow disclaimer of express or implied warranties in certain transactions, therefore, this statement may not apply to you.

This information could include technical inaccuracies or typographical errors. Changes are periodically made to the information herein; these changes will be incorporated in new editions of the publication. Lenovo may make improvements and/or changes in the product(s) and/or the program(s) described in this publication at any time without notice.

The products described in this document are not intended for use in implantation or other life support applications where malfunction may result in injury or death to persons. The information contained in this document does not affect or change Lenovo product specifications or warranties. Nothing in this document shall operate as an express or implied license or indemnity under the intellectual property rights of Lenovo or third parties. All information contained in this document was obtained in specific environments and is presented as an illustration. The result obtained in other operating environments may vary. Lenovo may use or distribute any of the information you supply in any way it believes appropriate without incurring any obligation to you.

Any references in this publication to non-Lenovo Web sites are provided for convenience only and do not in any manner serve as an endorsement of those Web sites. The materials at those Web sites are not part of the materials for this Lenovo product, and use of those Web sites is at your own risk. Any performance data contained herein was determined in a controlled environment. Therefore, the result obtained in other operating environments may vary significantly. Some measurements may have been made on development-level systems and there is no guarantee that these measurements will be the same on generally available systems. Furthermore, some measurements may have been estimated through extrapolation. Actual results may vary. Users of this document should verify the applicable data for their specific environment.

**© Copyright Lenovo 2017. All rights reserved.**

This document, TIPS0885, was created or updated on January 30, 2015.

Send us your comments in one of the following ways:

- Use the online Contact us review form found at:  
<http://lenovopress.com/TIPS0885>
- Send your comments in an e-mail to:  
[comments@lenovopress.com](mailto:comments@lenovopress.com)

This document is available online at <http://lenovopress.com/TIPS0885>.



## Trademarks

Lenovo, the Lenovo logo, and For Those Who Do are trademarks or registered trademarks of Lenovo in the United States, other countries, or both. A current list of Lenovo trademarks is available on the Web at <http://www3.lenovo.com/us/en/legal/copytrade/>.

The following terms are trademarks of Lenovo in the United States, other countries, or both:

BladeCenter®  
Flex System™  
Lenovo Services™  
Lenovo®  
ServeRAID™  
ServerGuide™  
ServerProven®  
System x®

The following terms are trademarks of other companies:

Intel®, Pentium®, and Intel Xeon® are trademarks or registered trademarks of Intel Corporation or its subsidiaries in the United States and other countries.

Linux® is a trademark of Linus Torvalds in the United States, other countries, or both.

Microsoft® and Windows® are trademarks of Microsoft Corporation in the United States, other countries, or both.

Other company, product, or service names may be trademarks or service marks of others.