



Hewlett Packard
Enterprise

HPE ProLiant DL380 Gen10 Plus Server Maintenance and Service Guide

Part Number: 30-88124EA0-003

Published: October 2021

Edition: 3

HPE ProLiant DL380 Gen10 Plus Server Maintenance and Service Guide

Abstract

This document is for the person who installs, administers, and troubleshoots servers and storage systems. Hewlett Packard Enterprise assumes you are qualified in the servicing of computer equipment and trained in recognizing hazards in products with hazardous energy levels.

Part Number: 30-88124EA0-003

Published: October 2021

Edition: 3

© Copyright 2021 Hewlett Packard Enterprise Development LP

Notices

The information contained herein is subject to change without notice. The only warranties for Hewlett Packard Enterprise products and services are set forth in the express warranty statements accompanying such products and services. Nothing herein should be construed as constituting an additional warranty. Hewlett Packard Enterprise shall not be liable for technical or editorial errors or omissions contained herein.

Confidential computer software. Valid license from Hewlett Packard Enterprise required for possession, use, or copying. Consistent with FAR 12.211 and 12.212, Commercial Computer Software, Computer Software Documentation, and Technical Data for Commercial Items are licensed to the U.S. Government under vendor's standard commercial license.

Links to third-party websites take you outside the Hewlett Packard Enterprise website. Hewlett Packard Enterprise has no control over and is not responsible for information outside the Hewlett Packard Enterprise website.

Acknowledgments

Intel[®], Itanium[®], Optane[™], Pentium[®], Xeon[®], Intel Inside[®], and the Intel Inside logo are trademarks of Intel Corporation in the U.S. and other countries.

Microsoft[®], Windows[®], and Windows Server[®] are either registered trademarks or trademarks of Microsoft Corporation in the United States and/or other countries.

Linux[®] is the registered trademark of Linus Torvalds in the U.S. and other countries.

VMware ESXi[™] and VMware vSphere[®] are registered trademarks or trademarks of VMware, Inc. in the United States and/or other jurisdictions.

Red Hat[®] Enterprise Linux[®] are registered trademarks of Red Hat, Inc. in the United States and other countries.

microSD[®] is a trademark or a registered trademark of SD-3D in the United States, other countries of both.

All third-party marks are property of their respective owners.

Table of contents

- Illustrated parts catalog
 - Mechanical components
 - Air baffle spare parts
 - Access panel spare parts
 - Tertiary PCI riser cage spare part
 - Primary and secondary PCI riser cage spare part
 - Chassis ears spare parts
 - Fan cage spare part
 - 2U bezel spare part
 - Rail kit spare parts
 - Miscellaneous mechanical spare parts
 - Hard drive blank spare part
 - Miscellaneous rear blanks spare parts
 - Fan blanks, energy pack latch, and retention clips spare kit
 - Optical drive blank spare part
 - System components
 - DIMM spare parts
 - Persistent memory module spare parts
 - Processor spare parts
 - Third Generation Intel Xeon Scalable Processors
 - 43XX processor spare parts
 - 53XX processor spare parts
 - 63xx processor spare parts
 - 83xx processor spare parts
 - Heatsink spare parts
 - Power supply spare parts
 - Controller spare parts
 - Smart Array controller spare parts
 - Host bus adapter spare parts
 - Infiniband adapter spare parts
 - Ethernet adapter spare parts
 - PCI riser board spare parts
 - Pensando Distributed Services Platform spare parts
 - OCP 3.0 adapter spare parts
 - System board assembly spare parts
 - System battery spare part
 - Server options
 - Drive spare parts
 - NVMe drive spare parts
 - SAS drive spare parts
 - SATA drive spare parts
 - Fan spare parts

- Backplane board spare parts
 - Chassis Intrusion Detection Switch spare part
 - Rear serial port interface spare part
 - Energy pack spare parts
 - HPE Smart Storage Hybrid Capacitor spare part
 - HPE Smart Storage Battery spare part
 - Power module spare parts
 - LFF front I/O board spare part
 - HPE NS204i-p NVMe OS Boot Device spare parts
 - HPE Trusted Platform Module 2.0 Gen10 Plus spare part
 - Cable spare parts
- Customer self repair
- Removal and replacement procedures
 - Required tools
 - Safety considerations
 - Electrostatic discharge
 - Symbols on equipment
 - Rack warnings and cautions
 - Server warnings and cautions
 - Preparation procedures
 - Accessing the Systems Insight Display
 - Power down the server
 - Extend the server from the rack
 - Remove the server from the rack
 - Releasing the cable management arm
 - Remove the access panel
 - Removing the air baffle
 - Release the full-length expansion board retainer
 - Removing and replacing the rack rails
 - Removing and replacing the cable management arm
 - Removing and replacing the front bezel
 - Removing and replacing a drive blank
 - Removing and replacing a hot-plug SAS, SATA or NVMe drive
 - Removing and replacing the hot-plug fan
 - Removing and replacing the fan cage
 - Removing and replacing a power supply blank
 - Removing and replacing a hot-plug AC power supply
 - Removing and replacing the HPE 800 W Flex Slot -48 VDC hot-plug power supply
 - Removing and replacing an HPE 1600 W Flex Slot -48 VDC hot-plug power supply
 - Removing and replacing the primary PCIe riser cage
 - Removing and replacing the secondary and tertiary PCIe riser cages
 - Removing and replacing the PCIe riser blank
 - Removing and replacing the PCIe riser board
 - Removing and replacing an expansion slot blank

- Removing and replacing an expansion board
- Removing and replacing a GPU enablement board
- Removing and replacing the fan cage
- Removing and replacing the OCP NIC 3.0 adapter
- Removing and replacing the SFF universal media bay
- Removing and replacing the LFF power switch module
- Removing and replacing the SFF optical drive
- Removing and replacing the LFF optical drive
- Removing and replacing the 8 SFF drive cage
- Removing and replacing the 8 SFF drive backplane
- Removing and replacing the 2 SFF front drive cage
- Removing and replacing the 2 SFF rear drive bay and riser cage
- Removing and replacing the 2 SFF drive cage
- Removing and replacing the 2 SFF rear drive backplane
- Removing and replacing a midplane drive cage
- Removing and replacing the midplane drive backplane
- Removing and replacing the 2LFF rear drive bay and riser cage
- Removing and replacing the LFF backplane assembly
- Removing and replacing a front LFF drive backplane
- Removing and replacing a rear serial port interface (primary)
- Removing and replacing an SFF power switch module
- Removing and replacing an SFF standard chassis ear
- Removing and replacing the LFF chassis ear assembly
- Removing and replacing an LFF chassis ear with power/UID
- Removing and replacing the front I/O board in the LFF right chassis ear
- Removing and replacing the chassis intrusion detection switch
- Removing and replacing a DIMM
- Removing a DIMM or persistent memory module
 - Persistent memory module handling guidelines
 - Disabling encryption for a persistent memory module
 - Configuring the server for Intel Optane persistent memory 200 series for HPE
- Removing and replacing an energy pack
- Removing and replacing a type-a Smart Array Controller
- Removing and replacing the Pensando DSP DSC-25 2p SFP28 card
 - Decommissioning the Pensando DSP DSC-25 2p SFP28 card
 - Removing the Pensando DSP DSC-25 2p SFP28 card
 - Replacing the Pensando DSP DSC-25 2p SFP28 card
- Removing and replacing the HPE NS204i-p NVMe OS Boot Device option
 - Removing and replacing the boot device
 - Removing and replacing a boot device drive
 - Relocating the M.2 drive retaining latches
- Removing and replacing a processor or heatsink
- Removing and replacing the system battery
- Removing and replacing the system board

- Re-entering the server serial number and product ID
- HPE Trusted Platform Module 2.0 Gen10 Plus option
- Troubleshooting
 - Troubleshooting resources
- Diagnostic tools
 - UEFI System Utilities
 - Selecting the boot mode
 - Secure Boot
 - Launching the Embedded UEFI Shell
 - iLO Service Port
 - Intelligent Provisioning
 - HPE Insight Remote Support
 - HPE InfoSight for servers
 - USB support
 - External USB functionality
 - Smart Storage Administrator
- Component identification
 - Front panel components
 - Front panel LEDs and buttons
 - UID button functionality
 - Front panel LED power fault codes
 - Systems Insight Display LEDs
 - Systems Insight Display combined LED descriptions
 - Rear panel components
 - Rear panel LEDs
 - System board components
 - Heatsink and socket components
 - DIMM label identification
 - Intel Optane persistent memory 200 series for HPE label identification
 - DIMM slot locations
 - System maintenance switch descriptions
 - Drive box identification
 - Drive numbering
 - HPE Basic Drive LED definitions
 - Fan bay numbering
 - DSC-25 2-port SFP28 card ports and LEDs
 - HPE NS204i-p NVMe OS Boot Device components
 - HPE NS204i-p NVMe OS Boot Device LED definitions
- Cabling
 - Cabling guidelines
 - Power cabling
 - Cable routing: Front 8SFF power cabling
 - Cable routing: Front 12LFF power cabling
 - Cable routing: Midplane power cabling

- Cable routing: Front 2SFF side-by-side power cabling
 - Cable routing: Rear 2SFF power cabling
 - Cabling diagrams
 - Cable routing: 2NVMe box 6 to AROC NVMe adapter
 - Cable routing: 6NVMe box 3 to 3-port primary riser
 - Cable routing: 6NVMe box 3 to 3-port primary riser
 - Cable routing: 8NVMe balanced box 2 to system board
 - Cable routing: 8NVMe P2 box 1 to system board/secondary riser
 - Cable routing: 8NVMe P1 box 3 to system board/primary riser
 - Cable routing: 12NVMe BAL P1 box 2+3 to system board/primary riser/OCP NVMe adapter/Type-a controller
 - Cable routing: 12NVMe BAL P2 box 1+2 to system board/4-port NVMe secondary riser
 - Cable routing: 12NVMe DIFF P1 box 2+3 to system board/4-port NVMe primary riser
 - Cable routing: 12NVMe DIFF P1 box 1+2 to system board/4-port NVMe secondary riser
 - Cable routing: 24NVMe Balanced
 - Cable routing: 24NVMe Differential
 - Cable routing: 8NVMe box 3 to 4-port primary riser
 - Cable routing: 8NVMe box 1 to 4-port secondary riser
 - Cable routing: 8NVMe box 1+2 to type-a controller
 - Cable routing: 8SFF box 2 to type-a controller
 - Cable routing: 8SFF box 3 to 2-port primary type-p controller
 - Cable routing: 8SFF box 2 to 2-port primary type-p controller
 - Cable routing: 2SFF side-by-side to primary type-p controller
 - Cable routing: 8SFF 4-port box 1 to 4-port secondary type-p controller
 - Cable routing: 8SFF 4-port box 2 to 4-port primary type-p controller
 - Cable routing: 8SFF 4-port box 3 to 4-port primary type-p controller
 - Cable routing: 8SFF box 1+2+3 to 4-port secondary type-p controller
 - Cable routing: 8SFF box 1+2+3 to 4-port primary type-p controller
 - Cable routing: 4LFF SAS/SATA box 7 to 4-port type-a controller
 - Cable routing: Front I/O cabling
 - Cable routing: Serial port
 - Cable routing: OCP NVMe enablement
- Specifications
 - Environmental specifications
 - Mechanical specifications
 - Power supply specifications
 - HPE 800 W Flex Slot Universal Hot-plug Low Halogen Power Supply
 - HPE 800 W Flex Slot Platinum Hot-plug Low Halogen Power Supply
 - HPE 800 W Flex Slot Titanium Hot-plug Low Halogen Power Supply
 - HPE 800 W Flex Slot -48 VDC Hot-plug Low Halogen Power Supply
 - HPE 1600 W Flex Slot Platinum Hot-plug Low Halogen Power Supply
 - HPE 1600 W Flex Slot -48 VDC Hot-plug Power Supply
- Support and other resources
 - Accessing Hewlett Packard Enterprise Support
 - Accessing updates

- Remote support
- Warranty information
- Regulatory information
- Documentation feedback

Illustrated parts catalog

Mechanical components

Hewlett Packard Enterprise continually improves and changes product parts. For complete and current supported parts information, see the [Hewlett Packard Enterprise PartSurfer website](#).

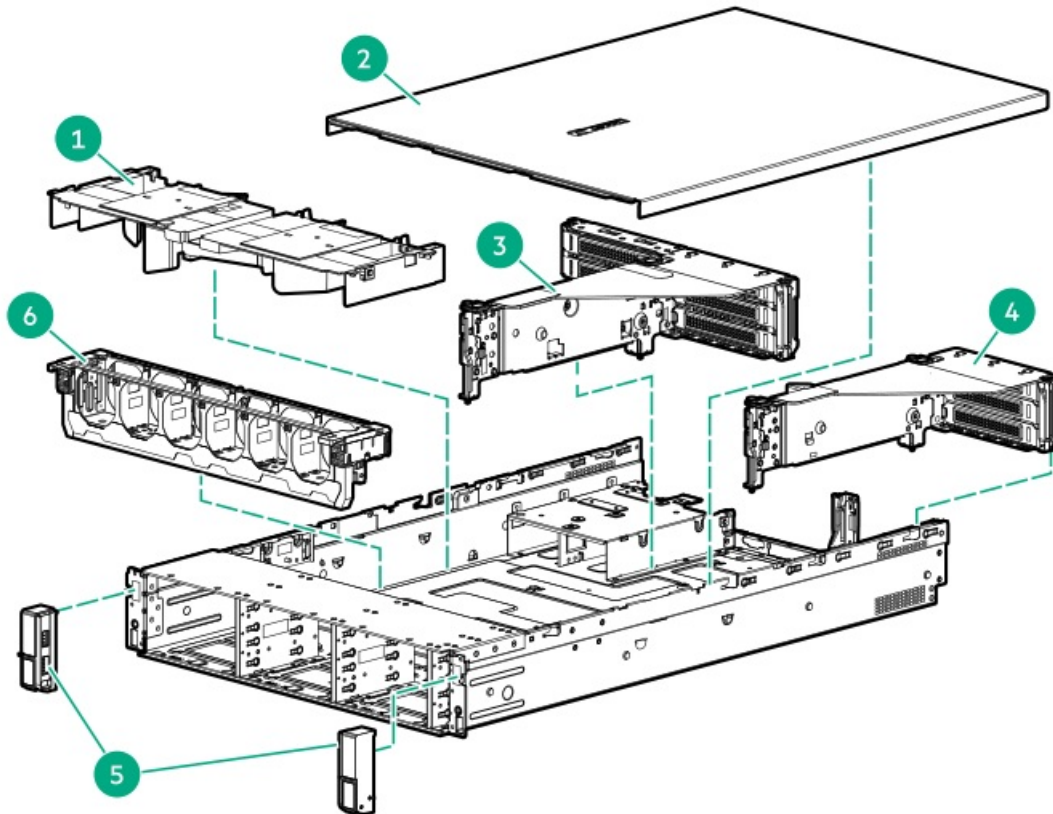

Item	Description
1	Air baffle spare parts
2	Access panel spare parts
3	Tertiary PCI riser cage spare part
4	Primary and secondary PCI riser cage spare part
5	Chassis ears spare parts
6	Fan cage spare part
7	2U bezel spare part*
8	Rail kit spare parts*
9	Miscellaneous mechanical spare parts*
	<ul style="list-style-type: none">• Hard drive blank spare part• Miscellaneous rear blanks spare parts

Item	Description
	<ul style="list-style-type: none"> • Fan blanks, energy pack latch, and retention clips spare kit
	<ul style="list-style-type: none"> • Optical drive blank spare part

* Not shown

For more information, see [Removal and replacement procedures](#).

Air baffle spare parts

Customer self repair: Mandatory

Description	Spare part number
Air baffle	P38194-001

Access panel spare parts

Customer self repair: Mandatory

Description	Spare part number
Access panel (SFF model)	P41709-001
Access panel (LFF model)	P41710-001

Tertiary PCI riser cage spare part

Customer self repair: Optional

Description	Spare part number
Tertiary PCI riser cage	P24030-001

Primary and secondary PCI riser cage spare part

Customer self repair: Mandatory

Description	Spare part number
Primary and secondary PCI riser cage	P24028-001

Chassis ears spare parts

Customer self repair: Mandatory

Description	Spare part number
SFF/LFF right and left ears kit plus power cable	P24141-001

Fan cage spare part

Customer self repair: Mandatory

Description	Spare part number
Fan cage	P24029-001

2U bezel spare part

Customer self repair: Mandatory

Description	Spare part number
2U bezel	875065-001

Rail kit spare parts

Customer self repair: Mandatory

Description	Spare part number
SFF 2U easy install rail kit	P24098-001
LFF 2U easy install rail kit	P24099-001
2U cable management arm	P24100-001

Description	Spare part number
-------------	-------------------

Miscellaneous mechanical spare parts

Hard drive blank spare part

Customer self repair: Mandatory

Description	Spare part number
LFF HDD blank kit	P15816-001
SFF HDD blank kit	652999-001

Miscellaneous rear blanks spare parts

Customer self repair: Mandatory

Description	Spare part number
Rear OCP blank	P24101-001
Quad NIC blank	P19929-001
Fan blanks, HPE Smart Storage Battery latch, retainers	875066-001
Serial port blank	P40857-001
Power supply blank	775423-001
Optical disk drive blank	707300-001

Fan blanks, energy pack latch, and retention clips spare kit

Customer self repair: Mandatory

Description	Spare part number
<ul style="list-style-type: none">Fan blanks (2)	P39788-001
<ul style="list-style-type: none">Energy pack latch	
<ul style="list-style-type: none">Retention clips for the primary riser cage (2)	
<ul style="list-style-type: none">Retention clip for the secondary/tertiary riser cage	

Optical drive blank spare part

Customer self repair: Mandatory

Description	Spare part number
Optical drive blank	707300-001

System components

Hewlett Packard Enterprise continually improves and changes product parts. For complete and current supported parts information, see the [Hewlett Packard Enterprise PartSurfer website](#).

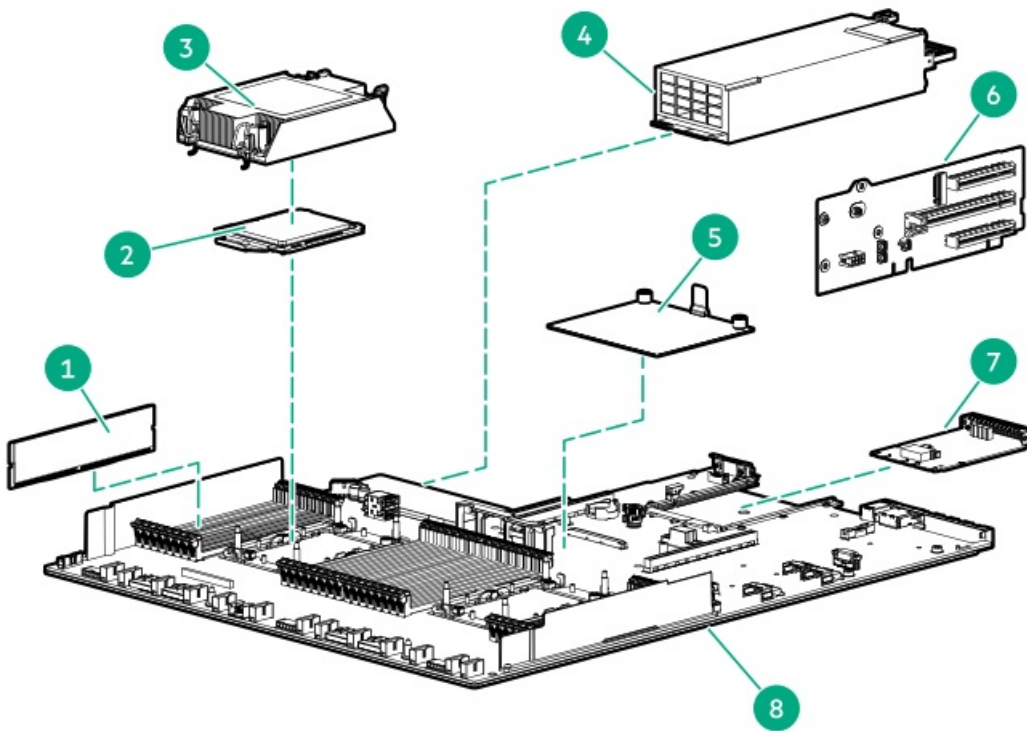

Item	Description
1	DIMM spare parts
	Persistent memory module spare parts
2	Processor spare parts
3	Heatsink spare parts
4	Power supply spare parts
5	Controller spare parts

Item Description

	<ul style="list-style-type: none">• Smart Array controller spare parts
	<ul style="list-style-type: none">• Host bus adapter spare parts
	<ul style="list-style-type: none">• Infiniband adapter spare parts
	<ul style="list-style-type: none">• Ethernet adapter spare parts
6	PCI riser board spare parts
7	OCP 3.0 adapter spare parts
8	System board assembly spare parts
9	System battery spare part*

* Not shown

For more information, see [Removal and replacement procedures](#).

DIMM spare parts

Customer self repair: Mandatory

3200 MT/s DIMMs

Description	Spare part number
8GB 1Rx8 PC4-3200AA-R Smart Kit	P21671-001
16GB 1Rx4 PC4-3200AA-R Smart Kit	P21672-001
16GB 2Rx8 PC4-3200AA-R Smart Kit	P21673-001
32GB 2Rx4 PC4-3200AA-R Smart Kit	P21674-001
64GB 2Rx4 PC4-3200AA-R Smart Kit	P21676-001
128GB 4Rx4 PC4-3200AA-L Smart Kit	P21677-001
256GB 8Rx4 PC4-3200AA-L 3DS Smart	P21678-001
32GB 1Rx4 PC4-3200AA-R Smart Kit	P41682-001

Persistent memory module spare parts

Customer self repair: Mandatory

Description	Spare part number
Intel Optane 128GB PMem 200 for HPE	P31373-001
Intel Optane 256GB PMem 200 for HPE	P31374-001
Intel Optane 512GB PMem 200 for HPE	P31375-001

Processor spare parts

Third Generation Intel Xeon Scalable Processors

43XX processor spare parts

Customer self repair: **Optional**

Description	Spare part number
Intel Xeon Silver 4309Y processor (8C, 105W, 2.8GHz)	P44450-001
Intel Xeon Silver 4310 processor (2.1G, 12C, 120W)	P44449-001
Intel Xeon Silver 4314 processor (2.4G, 16C, 135W)	P44448-001
Intel Xeon Silver 4316 processor (2.3G, 20C, 150W)	P44447-001

53XX processor spare parts

Customer self repair: **Optional**

Description	Spare part number
Intel Xeon-G 5315Y 3.2G, 8C, 140W processor	P44443-001
Intel Xeon-G 5317 3.0G, 12C, 150W processor	P44442-001
Intel Xeon-G 5318N 2.1G, 24C, 135W	P44438-001
Intel Xeon-G 5318S 2.1G, 24C, 165W processor	P44433-001
Intel Xeon-G 5318Y 2.1G, 24C, 165W processor	P44446-001
Intel Xeon-G 5320 2.2G, 26C, 185W processor	P44445-001

63xx processor spare parts

Customer self repair: **Optional**

Description	Spare part number
Intel Xeon-G 6312U 2.4G, 24C, 185W processor	P44434-001
Intel Xeon-G 6342 2.8G, 24C, 230W processor	P44439-001
Intel Xeon-G 6334 3.6G, 8C, 165W processor	P44440-001
Intel Xeon-G 6326 2.9G, 16C, 185W processor	P44441-001
Intel Xeon-G 6336Y 2.4G, 24C, 185W processor	P44444-001
Intel Xeon-G 6330 2.0GHz 28c 205W processor	P41711-001
Intel Xeon-G 6338 2.0GHz 32c 205W processor	P41712-001
Intel Xeon-G 6346 3.1GHz 16c 205W processor	P41714-001
Intel Xeon-G 6354 3.0GHz 18c 205W processor	P41715-001
Intel Xeon-G 6348 2.6GHz 28c 235W processor	P41716-001
Intel Xeon-G 6338N 2.2GHz 32c 185W processor	P41725-001
Intel Xeon-G 6330N 2.2GHz 28c 165W processor	P41726-001
Intel Xeon-G 6314U 2.3GHz 32c 205W processor	P41727-001

83xx processor spare parts

Customer self repair: **Optional**

Description	Spare part number
Intel Xeon-P 8352Y 2.2GHz 32c 205W processor	P41713-001
Intel Xeon-P 8352M 2.3GHz 32c 185W processor	P46146 -001
Intel Xeon-P 8358 2.6GHz 32c 250W processor	P41717-001
Intel Xeon-P 8360Y 2.4GHz 36c 250W processor	P41718-001
Intel Xeon-P 8362 2.8GHz 32c 265W processor	P46147 -001
Intel Xeon-P 8368 2.4GHz 38c 270W processor	P41719-001
Intel Xeon-P 8380 2.3GHz 40c 270W processor	P41720-001
Intel Xeon-P 8358P 2.6GHz 32c 240W processor	P41721-001
Intel Xeon-P 8352V 2.1GHz 36c 195W processor	P41722-001
Intel Xeon-P 8351N 2.4GHz 36c 225W processor	P41724-001
Intel Xeon-P 8352S 2.2GHz 32c 205W processor	P41728-001

Heatsink spare parts

Customer self repair: **Optional**

Description	Spare part number
Standard heatsink	P31216-001
Performance heatsink	P31215-001

Power supply spare parts

Customer self repair: Mandatory

Description	Spare part number
HPE 800W Flex Slot Universal Hot-plug Low Halogen Power Supply	866727-001
HPE 800W Flex Slot Platinum Hot-plug Low Halogen Power Supply	P39385-001
HPE 800W Flex Slot Titanium Hot-plug Low Halogen Power Supply	866793-001
HPE 800W Flex Slot -48VDC Hot-plug Low Halogen Power Supply	866728-001
HPE 1600W Flex Slot -48VDC Hot-plug Power Supply	P18510-001
HPE 1600W Flex Slot Platinum Hot-plug Low Halogen Power Supply	P39384-001

Controller spare parts

Smart Array controller spare parts

Customer self repair: Mandatory

Description	Spare part number
HPE Smart Array P816i-a SR Gen10 Controller	836261-001
HPE Smart Array P408i-a SR Gen10 Controller	836260-001
HPE Smart Array E208i-a SR Gen10 Controller	836259-001
HPE Smart Array P408i-p SR Gen10 Controller	836269-001
HPE Smart Array P408e-p SR Gen10 Controller	836270-001
HPE Smart Array E208i-p SR Gen10 Controller	836266-001
HPE Smart Array E208e-p SR Gen10 Controller	836267-001
Broadcom MegaRAID MR216i-a Tri-Mode Gen10 Plus Controller	P28348-001
Broadcom MegaRAID MR216i-p Tri-Mode Gen10 Plus Controller	P28336-001
Broadcom MegaRAID MR416i-a Tri-Mode Gen10 Plus Controller	P28335-001
Broadcom MegaRAID MR416i-p Tri-Mode Gen10 Plus Controller	P17303-001
Microchip SmartRAID SR416i-a Tri-Mode Gen10 Plus Controller	P13928-001

Description	Spare part number
Microchip SmartRAID SR932i-p Tri-Mode Gen10 Plus Controller	P04223-001

Host bus adapter spare parts

Customer self repair: Mandatory

Description	Spare part number
HPE SN1200E 16Gb Single Port Fibre Channel Host Bus Adapter	870001-001
HPE SN1200E 16Gb Dual Port Fibre Channel Host Bus Adapter	870002-001
HPE SN1600E 32Gb Single Port Fibre Channel Host Bus Adapter	P31338-001
HPE SN1600E 32Gb Dual Port Fibre Channel Host Bus Adapter	869999-001
HPE SN1610E 32Gb 1-port Fibre Channel Host Bus Adapter	P14421-001
HPE SN1610E 32Gb 2-port Fibre Channel Host Bus Adapter	P14422-001
HPE SN1100Q 16Gb Single Port Fibre Channel Host Bus Adapter	863010-001
HPE SN1100Q 16Gb Dual Port Fibre Channel Host Bus Adapter	853011-001
HPE SN1600Q 32Gb Dual Port Fibre Channel Host Bus Adapter	868141-001
HPE SN1610Q 32Gb 1-port Fibre Channel Host Bus Adapter	P14419-001
HPE SN1610Q 32Gb 2-port Fibre Channel Host Bus Adapter	P14420-001

Infiniband adapter spare parts

Customer self repair: Mandatory

Description	Spare part number
HPE InfiniBand HDR/Ethernet 200Gb 1-port QSFP56 PCIe4 x16 MCX653105A-HDAT Adapter	P24754-001
HPE InfiniBand HDR/Ethernet 200Gb 2-port QSFP56 PCIe4 x16 MCX653106A-HDAT Adapter	P36072-001

Description	Spare part number
HPE 100Gb 1-port OP101 QSFP28 x16 PCIe Gen3 with Intel Omni-Path Architecture Adapter	829335-B21
HPE InfiniBand HDR100/Ethernet 100Gb 1-port QSFP56 PCIe4 x16 MCX653105A-ECAT Adapter	841703-001
HPE InfiniBand HDR100/Ethernet 100Gb 2-port QSFP56 PCIe4 x16 MCX653106A-ECAT Adapter	P24752-001

Ethernet adapter spare parts

Customer self repair: Mandatory

Description	Spare part number
Intel I350-T4 Ethernet 1Gb 4-port BASE-T Adapter	P22200-001
Broadcom BCM57416 Ethernet 10Gb 2-port BASE-T Adapter	P26987-001
Marvell QL41132HLRJ Ethernet 10Gb 2-port BASE-T Adapter	P11688-001
Broadcom BCM57412 Ethernet 10Gb 2-port SFP+ Adapter	P26874-001
Intel X710-DA2 Ethernet 10Gb 2-port SFP+ Adapter	P31328-001
Marvell QL41132HLCU Ethernet 10Gb 2-port SFP+ Adapter	P22199-001
Broadcom BCM57414 Ethernet 10/25Gb 2-port SFP28 Adapter	P26871-001
Intel E810-XXVDA2 Ethernet 10/25Gb 2-port SFP28 Adapter	P14483-001
Intel E810-XXVDA4 Ethernet 10/25Gb 4-port SFP28 Adapter	P10582-001
Mellanox MCX512F-ACHT Ethernet 10/25Gb 2-port SFP28 Adapter	P16004-001
Marvell QL41232HLCU Ethernet 10/25Gb 2-port SFP28 Adapter	P23451-001
Xilinx X2522-25G-PLUS Ethernet 10/25Gb 2-port SFP28 Adapter	P22204-001
Xilinx X2522-25G Ethernet 10/25Gb 2-port SFP28 Adapter	P24737-001
HPE Ethernet 100Gb 1-port QSFP28 PCIe3 x16 MCX515A-CCAT Adapter	P36071-001
Mellanox MCX623106AS-CDAT Ethernet 100Gb 2-port QSFP56 Adapter	P26155-001
Intel E810-CQDA2 Ethernet 100Gb 2-port QSFP28 Adapter	P22201-001
Mellanox MCX623105AS-VDAT Ethernet 200Gb 1-port QSFP56 Adapter	P14488-001
Marvell QL41134HLCU Ethernet 10Gb 4-port SFP+ Adapter	P13346-001
Mellanox MCX6314 Ethernet 10/25GbE 2-port SFP28 OCP3 Adapter	P42933-001
Mellanox MCX631102 Ethernet 10/25GbE 2-port SFP28 Adapter	P42934-001

PCI riser board spare parts

Customer self repair: Optional

Description	Spare part number
x16/x16 Slot 2/3 riser	P18720-001
x16 cabled riser	P24031-001
x16 Tertiary riser	P24034-001
2 x8, Tertiary riser	P24038-001
2Port, Tertiary riser	P24039-001
3 x16,Tri-mode riser	P24048-001
x16 2Port SlimSAS riser	P24181-001
4Port SlimSAS riser	P24182-001
x16, 3Port riser	P24184-001
x16/x16 Slot 1/2 riser	P18721-001
x8/x16/x8 Gen3 riser	P24043-001

Pensando Distributed Services Platform spare parts

Customer self repair: Optional

Description	Spare part number
Pensando Distributed Services Platform DSC-25 Enterprise 10/25Gb 2-port SFP28 Card	P27682-001

OCP 3.0 adapter spare parts

Customer self repair: Optional

Description	Spare part number
HPE ProLiant DL300 Gen10 Plus OCP x16 Enablement Kit	P24037-001
Intel I350-T4 Ethernet 1Gb 4-port BASE-T OCP3 Adapter	P14487-001
Broadcom BCM57416 Ethernet 10Gb 2-port BASE-T OCP3 Adapter	P13640-001
Marvell QL41132HQRJ Ethernet 10Gb 2-port BASE-T OCP3 Adapter	P13345-001

Description	Spare part number
Intel X710-DA2 Ethernet 10Gb 2-port SFP+ OCP3 Adapter	P31327-001
Marvell QL41132HQU Ethernet 10Gb 2-port SFP+ OCP3 Adapter	P11586-001
Intel E810-CQDA2 Ethernet 100Gb 2-port QSFP28 OCP3 Adapter	P24113-001
Broadcom BCM57414 Ethernet 10/25Gb 2-port SFP28 OCP3 Adapter	P14484-001
Intel E810-XXVDA2 Ethernet 10/25Gb 2-port SFP28 OCP3 Adapter	P14485-001
Mellanox MCX562A-ACAI Ethernet 10/25Gb 2-port SFP28 OCP3 Adapter	P12619-001
Marvell QL41232HQU Ethernet 10/25Gb 2-port SFP28 OCP3 Adapter	P11710-001
Broadcom BCM57412 Ethernet 10Gb 2-port SFP+ OCP3 Adapter	P26256-B21
HPE InfiniBand HDR/Ethernet 200Gb 1-port QSFP56 OCP3 PCIe4 x16 Adapter	P31323-B21
HPE InfiniBand HDR/Ethernet 200Gb 2-port QSFP56 OCP3 PCIe4 x16 Adapter	P31348-B21

System board assembly spare parts

Customer self repair: **Optional**

Description	Spare part number
System board for third-generation Intel Xeon scalable processors	P31231-001

System battery spare part

Customer self repair: **Mandatory**

Description	Spare part number
System battery	319603-001

Server options

Hewlett Packard Enterprise continually improves and changes product parts. For complete and current supported parts information, see the [Hewlett Packard Enterprise PartSurfer website](#).

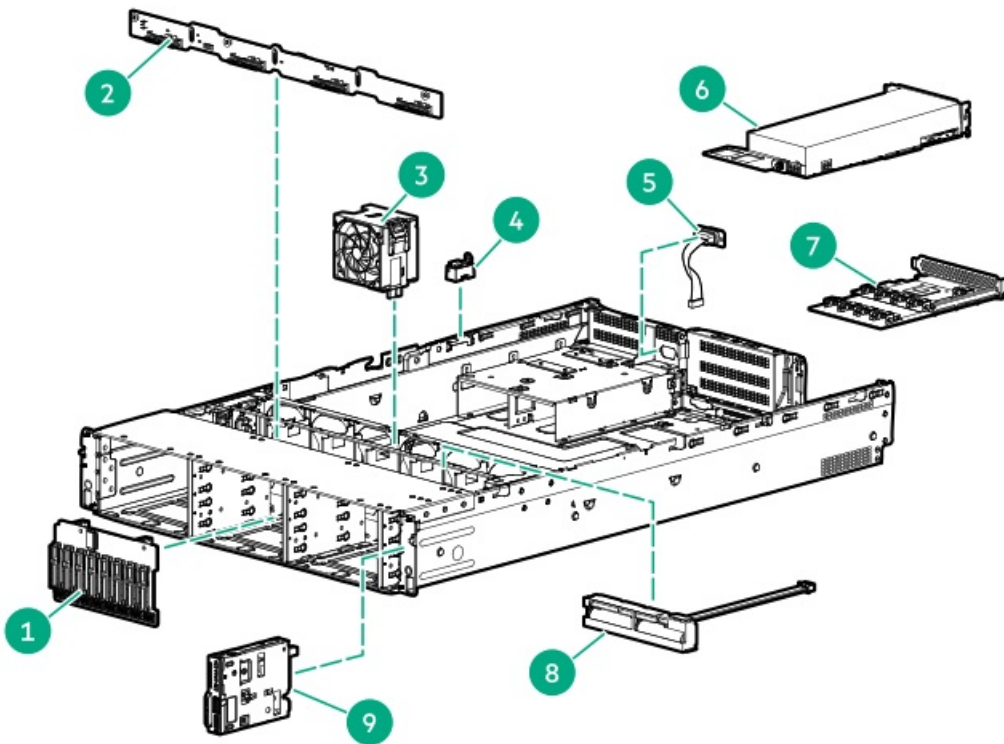

Item	Description
1	<u>Drive spare parts</u>
	<ul style="list-style-type: none"> • <u>NVMe drive spare parts</u> • <u>SAS drive spare parts</u> • <u>SATA drive spare parts</u>
2	<u>Backplane board spare parts</u>
3	<u>Fan spare parts</u>
4	<u>Chassis Intrusion Detection Switch spare part</u>
5	<u>Rear serial port interface spare part</u>
6	<u>Energy pack spare parts</u>
7	<u>Power module spare parts</u>
8	<u>LFF front I/O board spare part *</u>
9	<u>HPE Trusted Platform Module 2.0 Gen10 Plus spare part *</u>
10	<u>Cable spare parts *</u>

* Not shown

For more information, see [Removal and replacement procedures](#).

Drive spare parts

NVMe drive spare parts

Customer self repair: **Mandatory**

Description	Spare part number
HPE 800GB NVMe MU SFF BC U.3 PE8030 SSD	P41488-001
HPE 1.6TB NVMe MU SFF BC U.3 PE8030 SSD	P41492-001
HPE 3.2TB NVMe MU SFF BC U.3 PE8030 SSD	P41493-001
HPE 6.4TB NVMe MU SFF BC U.3 PE8030 SSD	P41494-001
HPE 800GB NVMe MU SFF BC U.3 CD6 SSD	P41511-001
HPE 1.6TB NVMe MU SFF BC U.3 CD6 SSD	P41512-001
HPE 3.2TB NVMe MU SFF BC U.3 CD6 SSD	P41513-001
HPE 6.4TB NVMe MU SFF BC U.3 CD6 SSD	P41514-001
HPE 960GB NVMe RI SFF BC U.3 PE8010 SSD	P41562-001
HPE 1.92TB NVMe RI BC U.3 PE8010 SSD	P41515-001
HPE 3.84TB NVMe RI BC U.3 PE8010 SSD	P41516-001
HPE 7.68TB NVMe RI BC U.3 PE8010 SSD	P41510-001
HPE 1.92TB NVMe RI SFF BC U.3 CD6 SSD	P41515-001
HPE 3.84TB NVMe RI SFF BC U.3 CD6 SSD	P41516-001
HPE 7.68TB NVMe RI SFF BC U.3 CD6 SSD	P41510-001
HPE 800GB NVMe MU SFF BC U.3 CM6 SSD	P41517-001
HPE 1.6TB NVMe MU SFF BC U.3 CM6 SSD	P41518-001
HPE 3.2TB NVMe MU SFF BC U.3 CM6 SSD	P41519-001
HPE 6.4TB NVMe MU SFF BC U.3 CM6 SSD	P41520-001
HPE 1.6TB NVMe MU SFF BC U.2 P4610 SSD	P41547-001
HPE 3.2TB NVMe MU SFF BC U.2 P4610 SSD	P41548-001
HPE 6.4TB NVMe MU SFF BC U.2 P4610 SSD	P41549-001
HPE 1.92TB NVMe RI SFF BC U.3 CM6 SSD	P41515-001
HPE 3.84TB NVMe RI SFF BC U.3 CM6 SSD	P41516-001
HPE 2TB NVMe RI SFF BC U.2 P4510 SSD	P41545-001
HPE 4TB NVMe RI SFF BC U.2 P4510 SSD	P41546-001
HPE 375GB NVMe WI SFF BC U.2 P4800x SSD	P41550-001
HPE 750GB NVMe WI SFF BC U.2 P4800x SSD	P41551-001

SAS drive spare parts

Customer self repair: **Mandatory**

LFF drives

Description	Spare part number
HPE 1.6TB SAS MU LFF LPC PM6 SSD	P41502-001
HPE 600GB SAS 15K LFF LPC HDD	P40783-001

SFF drives

Description	Spare part number
HPE 960GB SAS MU SFF BC VS MV SSD	P41535-001
HPE 1.92TB SAS MU SFF BC VS MV SSD	P41536-001
HPE 3.84TB SAS MU SFF BC VS MV SSD	P41537-001
HPE 960GB SAS RI SFF BC VS MV SSD	P41531-001
HPE 1.92TB SAS RI SFF BC VS MV SSD	P41532-001
HPE 3.84TB SAS RI SFF BC VS MV SSD	P41533-001
HPE 7.68TB SAS RI SFF BC VS MV SSD	P41534-001
HPE 800GB SAS MU SFF BC PM6 SSD	P41500-001
HPE 1.6TB SAS MU SFF BC PM6 SSD	P41501-001
HPE 3.2TB SAS MU SFF BC PM6 SSD	P41503-001
HPE 6.4TB SAS MU SFF BC PM6 SSD	P41504-001
HPE 800GB SAS MU SFF BC PM1645a SSD	P41558-001
HPE 1.6TB SAS MU SFF BC PM1645a SSD	P41559-001
HPE 3.2TB SAS MU SFF BC PM1645a SSD	P41560-001
HPE 6.4TB SAS MU SFF BC PM1645a SSD	P41561-001
HPE 800GB SAS MU SFF BC SS540 SSD	P41571-001
HPE 1.6TB SAS MU SFF BC SS540 SSD	P41572-001
HPE 3.2TB SAS MU SFF BC SS540 SSD	P41573-001
HPE 960GB SAS RI SFF BC PM6 SSD	P41495-001
HPE 1.92TB SAS RI SFF BC PM6 SSD	P41496-001
HPE 3.84TB SAS RI SFF BC PM6 SSD	P41497-001
HPE 7.68TB SAS RI SFF BC PM6 SSD	P41498-001
HPE 15.3TB SAS RI SFF BC PM6 SSD	P41499-001
HPE 960GB SAS RI SFF BC PM1643a SSD	P41554-001
HPE 1.92TB SAS RI SFF BC PM1643a SSD	P41555-001
HPE 3.84TB SAS RI SFF BC PM1643a SSD	P41556-001
HPE 7.68TB SAS RI SFF BC PM1643a SSD	P41557-001
HPE 400GB SAS WI SFF BC PM6 SSD	P41505-001
HPE 800GB SAS WI SFF BC PM6 SSD	P41506-001
HPE 800GB SAS WI SFF BC SS540 SSD	P41575-001
HPE 1.6TB SAS WI SFF BC PM6 SSD	P41507-001
HPE 400GB SAS WI SFF BC SS540 SSD	P41574-001
HPE 300GB SAS 15K SFF BC HDD	P30561-001
HPE 2.4TB SAS 10K SFF BC 512e HDD	P30562-001

Description	Spare part number
HPE 2TB SAS 7.2K SFF BC 512e HDD	P30575-001
HPE 1.2TB SAS 10K SFF BC HDD	P30563-001
HPE 300GB SAS 10K SFF BC HDD	P40785-001
HPE 900GB SAS 15K SFF BC HDD	P40784-001

SATA drive spare parts

Customer self repair: **Mandatory**

SFF drives

Description	Spare part number
HPE 960GB SATA MU SFF BC SED 5300M SSD	P42597-001
HPE 1.92TB SATA MU SFF BC SED 5300M SSD	P42598-001
HPE 480GB SATA RI SFF BC SED 5300P SSD	P42595-001
HPE 1.92TB SATA RI SFF BC SED 5300P SSD	P42596-001
HPE 480GB SATA MU SFF BC MV SSD	P41527-001
HPE 960GB SATA MU SFF BC MV SSD	P41528-001
HPE 1.92TB SATA MU SFF BC MV SSD	P41529-001
HPE 3.84TB SATA MU SFF BC MV SSD	P41530-001
HPE 240GB SATA RI SFF BC MV SSD	P41521-001
HPE 480GB SATA RI SFF BC MV SSD	P41522-001
HPE 960GB SATA RI SFF BC MV SSD	P41523-001
HPE 1.92TB SATA RI SFF BC MV SSD	P41524-001
HPE 3.84TB SATA RI SFF BC MV SSD	P41525-001
HPE 7.68TB SATA RI SFF BC MV SSD	P41526-001
HPE 480GB SATA MU SFF BC S4610 SSD	P41543-001
HPE 3.84TB SATA MU SFF BC S4610 SSD	P41544-001
HPE 1.92TB SATA RI SFF BC S4510 SSD	P41541-001
HPE 3.84TB SATA RI SFF BC S4510 SSD	P41542-001
HPE 7.68TB SATA VRO SFF BC 5210 SSD	P41553-001
HPE 2TB SATA 7.2K SFF BC 512e HDD	P30573-001
HPE 1TB SATA 7.2K SFF BC HDD	P30574-001
HPE 480GB SATA MU SFF BC PM897 SSD	P46049-001
HPE 960GB SATA MU SFF BC PM897 SSD	P46050-001
HPE 1.92TB SATA MU SFF BC PM897 SSD	P46051-001
HPE 480GB SATA MU SFF SC PM897 SSD	P48131-001
HPE 960GB SATA MU SFF SC PM897 SSD	P48132-001
HPE 1.92TB SATA MU SFF SC PM897 SSD	P48133-001

Description	Spare part number
HPE 480GB SATA RI SFF SC PM893 SSD	P48134-001
HPE 960GB SATA RI SFF SC PM893 SSD	P48135-001
HPE 1.92TB SATA RI SFF SC PM893 SSD	P48136-001
HPE 3.84TB SATA RI SFF SC PM893 SSD	P48137-001

Fan spare parts

Customer self repair: Mandatory

Description	Spare part number
Standard fan	P23971-001
High-performance fan	P23970-001

Backplane board spare parts

Customer self repair: Optional

Description	Spare part number
8SFF SAS/SATA backplane	P39777-001
2SFF U.3 x4 SAS/SATA/NVMe UBM3 backplane	P39783-001
2SFF SAS/SATA UBM2 backplane	P39778-001
2SFF x1 SAS/SATA UBM2 backplane	P39779-001
8SFF U.3 x 4 premium backplane	P39780-001
8SFF U.3 x1 basic backplane	P39781-001
4LFF SAS backplane	P23681-001
2SFF stacked U.3 x4 premium backplane	P39782-001
2LFF stacked/riser backplane	P24042-001
8SFF 2x4 U.3 x1 basic midplane	P39784-001
8SFF U.2 x4 UBM4 backplane	P39785-001

Chassis Intrusion Detection Switch spare part

Customer self repair: Mandatory

Description	Spare part number
Chassis Intrusion Detection Switch	P24555-001

Rear serial port interface spare part

Customer self repair: Mandatory

Description	Spare part number
Rear serial port interface	875571-001

Energy pack spare parts

HPE Smart Storage Hybrid Capacitor spare part

Customer self repair: mandatory

Description	Spare part number
HPE Smart Storage Hybrid Capacitor, 145mm cable	P07473-001

HPE Smart Storage Battery spare part

Customer self repair: Mandatory

Description	Spare part number
HPE Smart Storage Battery	878643-001

Power module spare parts

Customer self repair: Mandatory



Description	Spare part number
Power module without SID	P23972-001
Power/SID module	P40670-001
LFF power/optical drive module	P23973-001
Power module cable	P24127-001

LFF front I/O board spare part

Customer self repair: Optional

Description	Spare part number
LFF front I/O board	875088-001

HPE NS204i-p NVMe OS Boot Device spare parts

Customer self repair: Mandatory

Description	Spare part number
HPE NS204i-p NVMe OS Boot Device	P14379-001
480 GB NVMe x4 RI M.2 22110 DS SSD	P24886-001

HPE Trusted Platform Module 2.0 Gen10 Plus spare part

Customer self repair: No

Description	Spare part number
HPE Trusted Platform Module 2.0 Gen10 Plus	P23625-001

Cable spare parts

Customer self repair: Mandatory

Description	Spare part number
2SFF SAS/SATA cable kit <ul style="list-style-type: none"> X4 to 7p, SAS/SATA, 2SFF FRT/BK 	P24553-001
8NVMe cable kit <ul style="list-style-type: none"> Box 1/2, 8NVMe, P1-2 to MLB,1A-B/2A-B Box 2, 8NVMe, P3-4 to MLB,1B/2B Box 2, 8NVMe, P3 to type-a,7A 	P24554-001
Display port/USB/DVD/Serial cable kit <ul style="list-style-type: none"> Display PORT + USB 2.0 USB to USB Port, FRONT ODD, Slim SATA SERIAL PORT 	P24138-001
NVME Direct Connect Riser Cables, Bay2 splitter P1-4 x16 secondary <ul style="list-style-type: none"> Splitter, Box 2, P1-2 to X16, Secondary Splitter, Box 2, P3-4 to X16, Secondary 	P24135-001
NVME Direct Connect Riser Cables, Bay1 and Bay3 splitter P1-4 x16 primary <ul style="list-style-type: none"> Splitter, Box 3, P.P.1-4 to X16, Primary Splitter, Box 1, P.P.1-4 to X16, Primary 	P24134-001
NVME Direct Connect Riser Cables, Bay1 x16 pri/sec + Bay2 x32 primary/secondary <ul style="list-style-type: none"> Box 2, PP 1,2,3,4, to X32 Box 1, PP 1,2,3,4, to X32 Box 1, Media 2SFF-X16 	P24132-001
NVME Direct Connect Riser Cables, Bay1/2 P1/2 <ul style="list-style-type: none"> Box 2, PP 1, 2, to X32 Box 2, PP 3, 4, to X32 	P24131-001
NVME Direct Connect Riser Cables <ul style="list-style-type: none"> Box 3, P.P. 1-4 to R06 Riser Box 3, P. BP-Single X32 Box 2, Premium BP - MB Port 1-4 	P24130-001
OCP X8 RA PCIe P1/ P2 <ul style="list-style-type: none"> CPU to Riser Port 1, 686mm CPU to 2nd Riser, Port 1, 686mm 	P24129-001
Power cables kit <ul style="list-style-type: none"> I/O Wire to Board, FRONT PWR, 1x5 to 2x4, LFF, 240mm PWR, 1x5 to 2x4, LFF, 400mm PWR, 1x5 to 2x4 + x, LFF, 400mm PWR, 2x3 to 2x3, SFF PWR, 2x5 to 2x3 + 2x4 	P23361-001
8SFF mini-SAS kit	784621-001
SAS 2SFF+8SFF+AROC/H240+P440 Kit	784629-001
Power cables for 4LFF/8SFF kit	875096-001
Front I/O Board to Board	P24127-001
Midplane Prem/Basic to Board	P24133-001
Midplane to controller	P24136-001
Fan-Out cable SAS1-3 SAS/SATA-X8	P24137-001

Hewlett Packard Enterprise products are designed with many Customer Self Repair (CSR) parts to minimize repair time and allow for greater flexibility in performing defective parts replacement. If during the diagnosis period Hewlett Packard Enterprise (or Hewlett Packard Enterprise service providers or service partners) identifies that the repair can be accomplished by the use of a CSR part, Hewlett Packard Enterprise will ship that part directly to you for replacement. There are two categories of CSR parts:

- **Mandatory**—Parts for which customer self repair is mandatory. If you request Hewlett Packard Enterprise to replace these parts, you will be charged for the travel and labor costs of this service.
- **Optional**—Parts for which customer self repair is optional. These parts are also designed for customer self repair. If, however, you require that Hewlett Packard Enterprise replace them for you, there may or may not be additional charges, depending on the type of warranty service designated for your product.

 **NOTE:** Some Hewlett Packard Enterprise parts are not designed for customer self repair. In order to satisfy the customer warranty, Hewlett Packard Enterprise requires that an authorized service provider replace the part. These parts are identified as "No" in the Illustrated Parts Catalog.

Based on availability and where geography permits, CSR parts will be shipped for next business day delivery. Same day or four-hour delivery may be offered at an additional charge where geography permits. If assistance is required, you can call the Hewlett Packard Enterprise Support Center and a technician will help you over the telephone. Hewlett Packard Enterprise specifies in the materials shipped with a replacement CSR part whether a defective part must be returned to Hewlett Packard Enterprise. In cases where it is required to return the defective part to Hewlett Packard Enterprise, you must ship the defective part back to Hewlett Packard Enterprise within a defined period of time, normally five (5) business days. The defective part must be returned with the associated documentation in the provided shipping material. Failure to return the defective part may result in Hewlett Packard Enterprise billing you for the replacement. With a customer self repair, Hewlett Packard Enterprise will pay all shipping and part return costs and determine the courier/carrier to be used.

For more information about the Hewlett Packard Enterprise CSR program, contact your local service provider.

Parts only warranty service

Your Hewlett Packard Enterprise Limited Warranty may include a parts only warranty service. Under the terms of parts only warranty service, Hewlett Packard Enterprise will provide replacement parts free of charge.

For parts only warranty service, CSR part replacement is mandatory. If you request Hewlett Packard Enterprise to replace these parts, you will be charged for the travel and labor costs of this service.

Réparation par le client (CSR)

Les produits Hewlett Packard Enterprise comportent de nombreuses pièces CSR (Customer Self Repair = réparation par le client) afin de minimiser les délais de réparation et faciliter le remplacement des pièces défectueuses. Si pendant la période de diagnostic, Hewlett Packard Enterprise (ou ses partenaires ou mainteneurs agréés) détermine que la réparation peut être effectuée à l'aide d'une pièce CSR, Hewlett Packard Enterprise vous l'envoie directement. Il existe deux catégories de pièces CSR :

- **Obligatoire**—Pièces pour lesquelles la réparation par le client est obligatoire. Si vous demandez à Hewlett Packard Enterprise de remplacer ces pièces, les coûts de déplacement et main d'œuvre du service vous seront facturés.
- **Facultatif**—Pièces pour lesquelles la réparation par le client est facultative. Ces pièces sont également conçues pour permettre au client d'effectuer lui-même la réparation. Toutefois, si vous demandez à Hewlett Packard Enterprise de remplacer ces pièces, l'intervention peut ou non vous être facturée, selon le type de garantie applicable à votre produit.

REMARQUE: Certaines pièces Hewlett Packard Enterprise ne sont pas conçues pour permettre au client d'effectuer lui-même la réparation. Pour que la garantie puisse s'appliquer, Hewlett Packard Enterprise exige que le remplacement de la pièce soit effectué par un Mainteneur Agréé. Ces pièces sont identifiées par la mention "Non" dans le Catalogue illustré.

Les pièces CSR sont livrées le jour ouvré suivant, dans la limite des stocks disponibles et selon votre situation géographique. Si votre situation géographique le permet et que vous demandez une livraison le jour même ou dans les 4 heures, celle-ci vous sera facturée. Pour toute assistance, appelez le Centre d'assistance Hewlett Packard Enterprise pour qu'un technicien vous aide au téléphone. Dans les documents envoyés avec la pièce de rechange CSR, Hewlett Packard Enterprise précise s'il est nécessaire de lui retourner la pièce défectueuse. Si c'est le cas, vous devez le faire dans le délai indiqué, généralement cinq (5) jours ouvrés. La pièce et sa documentation doivent être retournées dans l'emballage fourni. Si vous ne retournez pas la pièce défectueuse, Hewlett Packard Enterprise se réserve le droit de vous facturer les coûts de remplacement. Dans le cas d'une pièce CSR, Hewlett Packard Enterprise supporte l'ensemble des frais d'expédition et de retour, et détermine la société de courses ou le transporteur à utiliser.

Pour plus d'informations sur le programme CSR de Hewlett Packard Enterprise, contactez votre Mainteneur Agréé local.

Service de garantie "pièces seules"

Votre garantie limitée Hewlett Packard Enterprise peut inclure un service de garantie "pièces seules". Dans ce cas, les pièces de rechange fournies par Hewlett Packard Enterprise ne sont pas facturées.

Dans le cadre de ce service, la réparation des pièces CSR par le client est obligatoire. Si vous demandez à Hewlett Packard Enterprise de remplacer ces pièces, les coûts de déplacement et main d'œuvre du service vous seront facturés.

Riparazione da parte del cliente

Per abbreviare i tempi di riparazione e garantire una maggiore flessibilità nella sostituzione di parti difettose, i prodotti Hewlett Packard Enterprise sono realizzati con numerosi componenti che possono essere riparati direttamente dal cliente (CSR, Customer Self Repair). Se in fase di diagnostica Hewlett Packard Enterprise (o un centro di servizi o di assistenza Hewlett Packard Enterprise) identifica il guasto come riparabile mediante un ricambio CSR, Hewlett Packard Enterprise lo spedisce direttamente al cliente per la sostituzione. Vi sono due categorie di parti CSR:

- **Obbligatorie**—Parti che devono essere necessariamente riparate dal cliente. Se il cliente ne affida la riparazione ad Hewlett Packard Enterprise, deve sostenere le spese di spedizione e di manodopera per il servizio.
- **Opzionali**—Parti la cui riparazione da parte del cliente è facoltativa. Si tratta comunque di componenti progettati per questo scopo. Se tuttavia il cliente ne richiede la sostituzione ad Hewlett Packard Enterprise, potrebbe dover sostenere spese aggiuntive a seconda del tipo di garanzia previsto per il prodotto.

NOTA: alcuni componenti Hewlett Packard Enterprise non sono progettati per la riparazione da parte del cliente. Per rispettare la garanzia, Hewlett Packard Enterprise richiede che queste parti siano sostituite da un centro di assistenza autorizzato. Tali parti sono identificate da un "No" nel Catalogo illustrato dei componenti.

In base alla disponibilità e alla località geografica, le parti CSR vengono spedite con consegna entro il giorno lavorativo seguente. La consegna nel giorno stesso o entro quattro ore è offerta con un supplemento di costo solo in alcune zone. In caso di necessità si può richiedere l'assistenza telefonica di un addetto del centro di supporto tecnico Hewlett Packard Enterprise. Nel materiale fornito con una parte di ricambio CSR, Hewlett Packard Enterprise specifica se il cliente deve restituire dei componenti. Qualora sia richiesta la resa ad Hewlett Packard Enterprise del componente difettoso, lo si deve spedire ad Hewlett Packard Enterprise entro un determinato periodo di tempo, generalmente cinque (5) giorni lavorativi. Il componente difettoso deve essere restituito con la documentazione associata nell'imballo di spedizione fornito. La mancata restituzione del componente può comportare la fatturazione del ricambio da parte di Hewlett Packard Enterprise. Nel caso di riparazione da parte del cliente, Hewlett Packard Enterprise sostiene tutte le spese di spedizione e resa e sceglie il corriere/vettore da utilizzare.

Per ulteriori informazioni sul programma CSR di Hewlett Packard Enterprise, contattare il centro di assistenza di zona.

Servizio di garanzia per i soli componenti

La garanzia limitata Hewlett Packard Enterprise può includere un servizio di garanzia per i soli componenti. Nei termini di garanzia del servizio per i soli componenti, Hewlett Packard Enterprise fornirà gratuitamente le parti di ricambio.

Per il servizio di garanzia per i soli componenti è obbligatoria la formula CSR che prevede la riparazione da parte del cliente. Se il cliente invece richiede la sostituzione ad Hewlett Packard Enterprise dovrà sostenere le spese di spedizione e di manodopera per il servizio.

Customer Self Repair

Hewlett Packard Enterprise Produkte enthalten viele CSR-Teile (Customer Self Repair), um Reparaturzeiten zu minimieren und höhere Flexibilität beim Austausch defekter Bauteile zu ermöglichen. Wenn Hewlett Packard Enterprise (oder ein Hewlett Packard Enterprise Servicepartner) bei der Diagnose feststellt, dass das Produkt mithilfe eines CSR-Teils repariert werden kann, sendet Ihnen Hewlett Packard Enterprise dieses Bauteil zum Austausch direkt zu. CSR-Teile werden in zwei Kategorien unterteilt:

- **Zwingend**—Teile, für die das Customer Self Repair-Verfahren zwingend vorgegeben ist. Wenn Sie den Austausch dieser Teile von Hewlett Packard Enterprise vornehmen lassen, werden Ihnen die Anfahrt- und Arbeitskosten für diesen Service berechnet.
- **Optional**—Teile, für die das Customer Self Repair-Verfahren optional ist. Diese Teile sind auch für Customer Self Repair ausgelegt. Wenn Sie jedoch den Austausch dieser Teile von Hewlett Packard Enterprise vornehmen lassen möchten, können bei diesem Service je nach den für Ihr Produkt vorgesehenen Garantiebedingungen zusätzliche Kosten anfallen.

HINWEIS: Einige Hewlett Packard Enterprise Teile sind nicht für Customer Self Repair ausgelegt. Um den Garantieanspruch des Kunden zu erfüllen, muss das Teil von einem Hewlett Packard Enterprise Servicepartner ersetzt werden. Im illustrierten Teilekatalog sind diese Teile mit „No“ bzw. „Nein“ gekennzeichnet.

CSR-Teile werden abhängig von der Verfügbarkeit und vom Lieferziel am folgenden Geschäftstag geliefert. Für bestimmte Standorte ist eine Lieferung am selben Tag oder innerhalb von vier Stunden gegen einen Aufpreis verfügbar. Wenn Sie Hilfe benötigen, können Sie das Hewlett Packard Enterprise Support Center anrufen und sich von einem Mitarbeiter per Telefon helfen lassen. Den Materialien von

Hewlett Packard Enterprise, die mit einem CSR-Ersatzteil geliefert werden, können Sie entnehmen, ob das defekte Teil an Hewlett Packard Enterprise zurückgeschickt werden muss. Wenn es erforderlich ist, das defekte Teil an Hewlett Packard Enterprise zurückzuschicken, müssen Sie dies innerhalb eines vorgegebenen Zeitraums tun, in der Regel innerhalb von fünf (5) Geschäftstagen. Das defekte Teil muss mit der zugehörigen Dokumentation in der Verpackung zurückgeschickt werden, die im Lieferumfang enthalten ist. Wenn Sie das defekte Teil nicht zurückschicken, kann Hewlett Packard Enterprise Ihnen das Ersatzteil in Rechnung stellen. Im Falle von Customer Self Repair kommt Hewlett Packard Enterprise für alle Kosten für die Lieferung und Rücksendung auf und bestimmt den Kurier-/Frachtdienst.

Weitere Informationen über das Hewlett Packard Enterprise Customer Self Repair Programm erhalten Sie von Ihrem Servicepartner vor Ort.

Parts-only Warranty Service (Garantieservice ausschließlich für Teile)

Ihre Hewlett Packard Enterprise Garantie umfasst möglicherweise einen Parts-only Warranty Service (Garantieservice ausschließlich für Teile). Gemäß den Bestimmungen des Parts-only Warranty Service stellt Hewlett Packard Enterprise Ersatzteile kostenlos zur Verfügung.

Für den Parts-only Warranty Service ist das CSR-Verfahren zwingend vorgegeben. Wenn Sie den Austausch dieser Teile von Hewlett Packard Enterprise vornehmen lassen, werden Ihnen die Anfahrt- und Arbeitskosten für diesen Service berechnet.

Reparaciones del propio cliente

Los productos de Hewlett Packard Enterprise incluyen muchos componentes que el propio usuario puede reemplazar (Customer Self Repair, CSR) para minimizar el tiempo de reparación y ofrecer una mayor flexibilidad a la hora de realizar sustituciones de componentes defectuosos. Si, durante la fase de diagnóstico, Hewlett Packard Enterprise (o los proveedores o socios de servicio de Hewlett Packard Enterprise) identifica que una reparación puede llevarse a cabo mediante el uso de un componente CSR, Hewlett Packard Enterprise le enviará dicho componente directamente para que realice su sustitución. Los componentes CSR se clasifican en dos categorías:

- **Obligatorio**—Componentes cuya reparación por parte del usuario es obligatoria. Si solicita a Hewlett Packard Enterprise que realice la sustitución de estos componentes, tendrá que hacerse cargo de los gastos de desplazamiento y de mano de obra de dicho servicio.
- **Opcional**—Componentes cuya reparación por parte del usuario es opcional. Estos componentes también están diseñados para que puedan ser reparados por el usuario. Sin embargo, si precisa que Hewlett Packard Enterprise realice su sustitución, puede o no conllevar costes adicionales, dependiendo del tipo de servicio de garantía correspondiente al producto.

NOTA: Algunos componentes de Hewlett Packard Enterprise no están diseñados para que puedan ser reparados por el usuario. Para que el usuario haga valer su garantía, Hewlett Packard Enterprise pone como condición que un proveedor de servicios autorizado realice la sustitución de estos componentes. Dichos componentes se identifican con la palabra "No" en el catálogo ilustrado de componentes.

Según la disponibilidad y la situación geográfica, los componentes CSR se enviarán para que lleguen a su destino al siguiente día laborable. Si la situación geográfica lo permite, se puede solicitar la entrega en el mismo día o en cuatro horas con un coste adicional. Si precisa asistencia técnica, puede llamar al Centro de asistencia técnica de Hewlett Packard Enterprise y recibirá ayuda telefónica por parte de un técnico. Con el envío de materiales para la sustitución de componentes CSR, Hewlett Packard Enterprise especificará si los componentes defectuosos deberán devolverse a Hewlett Packard Enterprise. En aquellos casos en los que sea necesario devolver algún componente a Hewlett Packard Enterprise, deberá hacerlo en el periodo de tiempo especificado, normalmente cinco días laborables. Los componentes defectuosos deberán devolverse con toda la documentación relacionada y con el embalaje de envío. Si no enviara el componente defectuoso requerido, Hewlett Packard Enterprise podrá cobrarle por el de sustitución. En el caso de todas sustituciones que lleve a cabo el cliente, Hewlett Packard Enterprise se hará cargo de todos los gastos de envío y devolución de componentes y escogerá la empresa de transporte que se utilice para dicho servicio.

Para obtener más información acerca del programa de Reparaciones del propio cliente de Hewlett Packard Enterprise, póngase en contacto con su proveedor de servicios local.

Servicio de garantía exclusivo de componentes

La garantía limitada de Hewlett Packard Enterprise puede que incluya un servicio de garantía exclusivo de componentes. Según las condiciones de este servicio exclusivo de componentes, Hewlett Packard Enterprise le facilitará los componentes de repuesto sin cargo adicional alguno.

Para este servicio de garantía exclusivo de componentes, es obligatoria la sustitución de componentes por parte del usuario (CSR). Si solicita a Hewlett Packard Enterprise que realice la sustitución de estos componentes, tendrá que hacerse cargo de los gastos de desplazamiento y de mano de obra de dicho servicio.

Customer Self Repair

Veel onderdelen in Hewlett Packard Enterprise producten zijn door de klant zelf te repareren, waardoor de reparatieduur tot een minimum beperkt kan blijven en de flexibiliteit in het vervangen van defecte onderdelen groter is. Deze onderdelen worden CSR-onderdelen (Customer Self Repair) genoemd. Als Hewlett Packard Enterprise (of een Hewlett Packard Enterprise Service Partner) bij de diagnose vaststelt dat de reparatie kan worden uitgevoerd met een CSR-onderdeel, verzendt Hewlett Packard Enterprise dat onderdeel rechtstreeks naar u, zodat u het defecte onderdeel daarmee kunt vervangen. Er zijn twee categorieën CSR-onderdelen:

- **Verplicht**—Onderdelen waarvoor reparatie door de klant verplicht is. Als u Hewlett Packard Enterprise verzoekt deze onderdelen voor u te vervangen, worden u voor deze service reiskosten en arbeidsloon in rekening gebracht.
- **Optioneel**—Onderdelen waarvoor reparatie door de klant optioneel is. Ook deze onderdelen zijn ontworpen voor reparatie door de klant. Als u echter Hewlett Packard Enterprise verzoekt deze onderdelen voor u te vervangen, kunnen daarvoor extra kosten in rekening worden gebracht, afhankelijk van het type garanteservice voor het product.

OPMERKING: Sommige Hewlett Packard Enterprise onderdelen zijn niet ontwikkeld voor reparatie door de klant. In verband met de garantievoorzieningen moet het onderdeel door een geautoriseerde Service Partner worden vervangen. Deze onderdelen worden in de geïllustreerde onderdelencatalogus aangemerkt met "Nee".

Afhankelijk van de leverbaarheid en de locatie worden CSR-onderdelen verzonden voor levering op de eerstvolgende werkdag. Levering op dezelfde dag of binnen vier uur kan tegen meerkosten worden aangeboden, indien dit mogelijk is gezien de locatie. Indien assistentie is gewenst, belt u het Hewlett Packard Enterprise Support Center om via de telefoon ondersteuning van een technicus te ontvangen. Hewlett Packard Enterprise vermeldt in de documentatie bij het vervangende CSR-onderdeel of het defecte onderdeel aan Hewlett Packard Enterprise moet worden geretourneerd. Als het defecte onderdeel aan Hewlett Packard Enterprise moet worden teruggezonden, moet u het defecte onderdeel binnen een bepaalde periode, gewoonlijk vijf (5) werkdagen, retourneren aan Hewlett Packard Enterprise. Het defecte onderdeel moet met de bijbehorende documentatie worden geretourneerd in het meegeleverde verpakkingsmateriaal. Als u het defecte onderdeel niet terugzendt, kan Hewlett Packard Enterprise u voor het vervangende onderdeel kosten in rekening brengen. Bij reparatie door de klant betaalt Hewlett Packard Enterprise alle verzendkosten voor het vervangende en geretourneerde onderdeel en kiest Hewlett Packard Enterprise zelf welke koerier/transportonderneming hiervoor wordt gebruikt.

Neem contact op met een Service Partner voor meer informatie over het Customer Self Repair programma van Hewlett Packard Enterprise.

Garanteservice "Parts Only"

Het is mogelijk dat de Hewlett Packard Enterprise garantie alleen de garanteservice "Parts Only" omvat. Volgens de bepalingen van de Parts Only garanteservice zal Hewlett Packard Enterprise kosteloos vervangende onderdelen ter beschikking stellen.

Voor de Parts Only garanteservice is vervanging door CSR-onderdelen verplicht. Als u Hewlett Packard Enterprise verzoekt deze onderdelen voor u te vervangen, worden u voor deze service reiskosten en arbeidsloon in rekening gebracht

Reparo feito pelo cliente

Os produtos da Hewlett Packard Enterprise são projetados com muitas peças para reparo feito pelo cliente (CSR) de modo a minimizar o tempo de reparo e permitir maior flexibilidade na substituição de peças com defeito. Se, durante o período de diagnóstico, a Hewlett Packard Enterprise (ou fornecedores/parceiros da Hewlett Packard Enterprise) concluir que o reparo pode ser efetuado pelo uso de uma peça CSR, a Hewlett Packard Enterprise enviará a peça diretamente ao cliente. Há duas categorias de peças CSR:

- **Obrigatória**—Peças cujo reparo feito pelo cliente é obrigatório. Se desejar que a Hewlett Packard Enterprise substitua essas peças, serão cobradas as despesas de transporte e mão-de-obra do serviço.
- **Opcional**—Peças cujo reparo feito pelo cliente é opcional. Essas peças também são projetadas para o reparo feito pelo cliente. No entanto, se desejar que a Hewlett Packard Enterprise as substitua, pode haver ou não a cobrança de taxa adicional, dependendo do tipo de serviço de garantia destinado ao produto.

OBSERVAÇÃO: Algumas peças da Hewlett Packard Enterprise não são projetadas para o reparo feito pelo cliente. A fim de cumprir a garantia do cliente, a Hewlett Packard Enterprise exige que um técnico autorizado substitua a peça. Essas peças estão identificadas com a marca "No" (Não), no catálogo de peças ilustrado.

Conforme a disponibilidade e o local geográfico, as peças CSR serão enviadas no primeiro dia útil após o pedido. Onde as condições geográficas permitirem, a entrega no mesmo dia ou em quatro horas pode ser feita mediante uma taxa adicional. Se precisar de auxílio, entre em contato com o Centro de suporte técnico da Hewlett Packard Enterprise para que um técnico o ajude por telefone. A Hewlett Packard Enterprise especifica nos materiais fornecidos com a peça CSR de reposição se a peça com defeito deve ser devolvida à Hewlett Packard Enterprise. Nos casos em que isso for necessário, é preciso enviar a peça com defeito à Hewlett Packard Enterprise, você deverá enviar a peça com defeito de volta para a Hewlett Packard Enterprise dentro do período de tempo definido, normalmente em 5 (cinco) dias úteis. A peça com defeito deve ser enviada com a documentação correspondente no material de transporte fornecido. Caso não o faça, a Hewlett Packard Enterprise poderá cobrar a reposição. Para as peças de reparo feito pelo cliente, a Hewlett Packard Enterprise paga todas as despesas de transporte e de devolução da peça e determina a transportadora/serviço postal a ser utilizado.

Para obter mais informações sobre o programa de reparo feito pelo cliente da Hewlett Packard Enterprise, entre em contato com o fornecedor de serviços local.

Service de garantia apenas para peças

A garantia limitada da Hewlett Packard Enterprise pode incluir um serviço de garantia apenas para peças. Segundo os termos do serviço de garantia apenas para peças, a Hewlett Packard Enterprise fornece as peças de reposição sem cobrar nenhuma taxa.

No caso desse serviço, a substituição de peças CSR é obrigatória. Se desejar que a Hewlett Packard Enterprise substitua essas peças, serão cobradas as despesas de transporte e mão-de-obra do serviço.

カスタマーセルフリペア

修理時間を短縮し、故障部品の交換における高い柔軟性を確保するために、Hewlett Packard Enterprise製品には多数のカスタマーセルフリペア（CSR）部品があります。診断の際に、CSR部品を使用すれば修理ができるとHewlett Packard Enterprise（Hewlett Packard EnterpriseまたはHewlett Packard Enterprise正規保守代理店）が判断した場合、Hewlett Packard Enterpriseはその部品を直接、お客様に発送し、お客様に交換していただきます。CSR部品には以下の2種類があります。

- **必須** - カスタマーセルフリペアが必須の部品。当該部品について、もしもお客様がHewlett Packard Enterpriseに交換作業を依頼される場合には、その修理サービスに関する交通費および人件費がお客様に請求されます。
- **任意** - カスタマーセルフリペアが任意である部品。この部品もカスタマーセルフリペア用です。当該部品について、もしもお客様がHewlett Packard Enterpriseに交換作業を依頼される場合には、お買い上げの製品に適用される保証サービス内容の範囲内においては、別途費用を負担していただくことなく保証サービスを受けることができます。

注：Hewlett Packard Enterprise製品の一部の部品は、カスタマーセルフリペアの対象外です。製品の保証を継続するためには、Hewlett Packard EnterpriseまたはHewlett Packard Enterprise正規保守代理店による交換作業が必須となります。部品カタログには、当該部品がカスタマーセルフリペア除外品である旨が記載されています。

部品供給が可能な場合、地域によっては、CSR部品を翌営業日に届くように発送します。また、地域によっては、追加費用を負担いただくことにより同日または4時間以内に届くように発送することも可能な場合があります。サポートが必要なときは、Hewlett Packard Enterpriseサポートセンターに電話していただければ、技術者が電話でアドバイスします。交換用のCSR部品または同梱物には、故障部品をHewlett Packard Enterpriseに返送する必要があるかどうかが表示されています。故障部品をHewlett Packard Enterpriseに返送する必要がある場合は、指定期限内（通常は5営業日以内）に故障部品をHewlett Packard Enterpriseに返送してください。故障部品を返送する場合は、届いた時の梱包箱に関連書類とともに入れてください。故障部品を返送しない場合、Hewlett Packard Enterpriseから部品費用が請求されます。カスタマーセルフリペアの際には、Hewlett Packard Enterpriseは送料および部品返送費を全額負担し、使用する宅配便会社や運送会社を指定します。

部品のみ保証サービス

Hewlett Packard Enterprise保証サービスには、部品のみ保証サービスが適用される場合があります。このサービスでは、交換部品は無償で提供されます。

部品のみ保証サービスにおいては、CSR部品をお客様により交換作業していただくことが必須となります。当該部品について、もしもお客様がHewlett Packard Enterpriseに交換作業を依頼される場合には、その修理サービスに関する交通費および人件費がお客様のご負担となります。

客户自行维修

Hewlett Packard Enterprise 产品提供许多客户自行维修 (CSR) 部件，以尽可能缩短维修时间和在更换缺陷部件方面提供更大的灵活性。如果在诊断期间 Hewlett Packard Enterprise (或 Hewlett Packard Enterprise 服务提供商或服务合作伙伴) 确定可以通过使用 CSR 部件完成维修，Hewlett Packard Enterprise 将直接把该部件发送给您进行更换。有两类 CSR 部件：

- **强制性的** — 要求客户必须自行维修的部件。如果您请求 Hewlett Packard Enterprise 更换这些部件，则必须为该服务支付差旅费和人工费用。
- **可选的** — 客户可以选择是否自行维修的部件。这些部件也是为客户自行维修设计的。不过，如果您要求 Hewlett Packard Enterprise 为您更换这些部件，则根据为您的产品指定的保修服务类型，Hewlett Packard Enterprise 可能收取或不再收取任何附加费用。

注：某些 Hewlett Packard Enterprise 部件的设计并未考虑客户自行维修。为了满足客户保修的需要，Hewlett Packard Enterprise 要求授权服务提供商更换相关部件。这些部件在部件图解目录中标记为“否”。

CSR 部件将在下一个工作日发运（取决于备货情况和允许的地理范围）。在允许的地理范围内，可在当天或四小时内发运，但要收取额外费用。如果需要帮助，您可以致电 Hewlett Packard Enterprise 技术支持中心，将会有技术人员通过电话为您提供帮助。Hewlett Packard Enterprise 会在随更换的 CSR 部件发运的材料中指明是否必须将有缺陷的部件返还给 Hewlett Packard Enterprise。如果要求您将有缺陷的部件返还给 Hewlett Packard Enterprise，那么您必须在规定的期限内（通常是五 (5) 个工作日）将缺陷部件发给 Hewlett Packard Enterprise。有缺陷的部件必须随所提供的发运材料中的相关文件一起返还。如果未能送还有缺陷的部件，Hewlett Packard Enterprise 可能会要求您支付更换费用。客户自行维修时，Hewlett Packard Enterprise 将承担所有相关运输和部件返回费用，并指定快递商/承运商。

有关 Hewlett Packard Enterprise 客户自行维修计划的详细信息，请与您当地的服务提供商联系。

仅部件保修服务

您的 Hewlett Packard Enterprise 有限保修服务可能涉及仅部件保修服务。根据仅部件保修服务条款的规定，Hewlett Packard Enterprise 将免费提供更换的部件。

仅部件保修服务要求进行 CSR 部件更换。如果您请求 Hewlett Packard Enterprise 更换这些部件，则必须为该服务支付差旅费和人工费用。

客戶自行維修

Hewlett Packard Enterprise 產品設計了許多「客戶自行維修」(CSR) 的零件以減少維修時間，並且使得更換瑕疵零件時能有更大的彈性。如果在診斷期間，Hewlett Packard Enterprise (或 Hewlett Packard Enterprise 服務供應商或維修夥伴) 辨認出此項維修工作可以藉由使用 CSR 零件來完成，則 Hewlett Packard Enterprise 將直接寄送該零件給您作更換。CSR 零件分為兩種類別：

- **強制的** — 客戶自行維修所使用的零件是強制性的。如果您要求 Hewlett Packard Enterprise 更換這些零件，Hewlett Packard Enterprise 將會向您收取此服務所需的外出費用與勞動成本。
- **選購的** — 客戶自行維修所使用的零件是選購的。這些零件也設計用於客戶自行維修之用。不過，如果您要求 Hewlett Packard Enterprise 為您更換，則可能需要也可能不需要負擔額外的費用，端視針對此產品指定的保固服務類型而定。

備註：某些 Hewlett Packard Enterprise 零件沒有消費者可自行維修的設計。為符合客戶保固，Hewlett Packard Enterprise 需要授權的服務供應商更換零件。這些零件在圖示的零件目錄中，被標示為「否」。

基於材料取得及環境允許的情況下，CSR 零件將於下一個工作日以快遞寄送。在環境的允許下當天或四小時內送達，則可能需要額外的費用。若您需要協助，可致電 Hewlett Packard Enterprise 支援中心，會有一位技術人員透過電話來協助您。不論損壞的零件是否必須退回，Hewlett Packard Enterprise 皆會在與 CSR 替換零件一起運送的材料中註明。若要將損壞的零件退回 Hewlett Packard Enterprise，您必須在指定的一段時間內 (通常為五 (5) 個工作天)，將損壞的零件寄回 Hewlett Packard Enterprise。損壞的零件必須與寄送資料中隨附的相關技術文件一併退還。如果無法退還損壞的零件，Hewlett Packard Enterprise 可能要向您收取替換費用。針對客戶自行維修情形，Hewlett Packard Enterprise 將負責所有運費及零件退還費用，並指定使用何家快遞/貨運公司。

如需 Hewlett Packard Enterprise 的 CSR 方案詳細資訊，請連絡您當地的服務供應商。

僅限零件的保固服務

您的「Hewlett Packard Enterprise 有限保固」可能包含僅限零件的保固服務。在僅限零件的保固服務情況下，Hewlett Packard Enterprise 將免費提供替換零件。

針對僅限零件的保固服務，CSR 零件替換是強制性的。如果您要求 Hewlett Packard Enterprise 更換這些零件，Hewlett Packard Enterprise 將會向您收取此服務所需的外出費用與勞動成本。

고객 셀프 수리

Hewlett Packard Enterprise 제품은 수리 시간을 최소화하고 결함이 있는 부품 교체 시 더욱 융통성을 발휘할 수 있도록 하기 위해 고객 셀프 수리(CSR) 부품을 다량 사용하여 설계되었습니다. 진단 기간 동안 Hewlett Packard Enterprise(또는 Hewlett Packard Enterprise 서비스 공급업체 또는 서비스 협력업체)에서 CSR 부품을 사용하여 수리가 가능하다고 판단되면 Hewlett Packard Enterprise는 해당 부품을 바로 사용자에게 보내어 사용자가 교체할 수 있도록 합니다. CSR 부품에는 두 가지 종류가 있습니다.

- **필수** - 고객 셀프 수리가 의무 사항인 필수 부품. 사용자가 Hewlett Packard Enterprise에 이 부품의 교체를 요청할 경우 이 서비스에 대한 출장비 및 작업비가 청구됩니다.
- **선택 사항** - 고객 셀프 수리가 선택 사항인 부품. 이 부품들도 고객 셀프 수리가 가능하도록 설계되었습니다. 하지만 사용자가 Hewlett Packard Enterprise에 이 부품의 교체를 요청할 경우 사용자가 구입한 제품에 해당하는 보증 서비스 유형에 따라 추가 비용 없이 교체가 가능할 수 있습니다.

참고: 일부 Hewlett Packard Enterprise 제품은 고객 셀프 수리가 불가능하도록 설계되었습니다. Hewlett Packard Enterprise는 만족스러운 고객 보증을 위해 공인 서비스 제공업체를 통해 부품을 교체하도록 하고 있습니다. 이러한 부품들은 Illustrated Parts Catalog에 "No"라고 표시되어 있습니다.

CSR 부품은 재고 상태와 지리적 조건이 허용하는 경우 다음 영업일 납품이 가능하도록 배송이 이루어집니다. 지리적 조건이 허용하는 경우 추가 비용이 청구되는 조건으로 당일 또는 4시간 배송이 가능할 수도 있습니다. 도움이 필요하시면 Hewlett Packard Enterprise Support Center로 전화하십시오. 전문 기술자가 전화로 도움을 줄 것입니다. Hewlett Packard Enterprise는 결함이 발생한 부품을 Hewlett Packard Enterprise로 반환해야 하는지 여부를 CSR 교체 부품과 함께 배송된 자료에 지정합니다. 결함이 발생한 부품을 Hewlett Packard Enterprise로 반환해야 하는 경우에는 지정된 기간 내(통상 영업일 기준 5일)에 Hewlett Packard Enterprise로 반환해야 합니다. 이때 결함이 발생한 부품은 제공된 포장 재료에 넣어 관련 설명서와 함께 반환해야 합니다. 결함이 발생한 부품을 반환하지 않는 경우 Hewlett Packard Enterprise가 교체 부품에 대해 비용을 청구할 수 있습니다. 고객 셀프 수리의 경우, Hewlett Packard Enterprise는 모든 운송 및 부품 반환 비용을 부담하며 이용할 운송업체 및 택배 서비스를 결정합니다.

Hewlett Packard Enterprise CSR 프로그램에 대한 자세한 내용은 가까운 서비스 제공업체에 문의하십시오.

부품 제공 보증 서비스

Hewlett Packard Enterprise 제한 보증에는 부품 제공 보증 서비스가 포함될 수 있습니다. 이러한 경우 Hewlett Packard Enterprise는 부품 제공 보증 서비스의 조건에 따라 교체 부품만을 무료로 제공합니다.

부품 제공 보증 서비스 제공 시 CSR 부품 교체는 의무 사항입니다. 사용자가 Hewlett Packard Enterprise에 이 부품의 교체를 요청할 경우 이 서비스에 대한 출장비 및 작업비가 청구됩니다.

Removal and replacement procedures

Required tools

You need the following items for some procedures:

- T-10 Torx screwdriver
- T-15 Torx screwdriver
- T-30 Torx screwdriver

Safety considerations

Before performing service procedures, review all the safety information.

Electrostatic discharge

Be aware of the precautions you must follow when setting up the system or handling components. A discharge of static electricity from a finger or other conductor may damage system boards or other static-sensitive devices. This type of damage may reduce the life expectancy of the system or component.

To prevent electrostatic damage:

- Avoid hand contact by transporting and storing products in static-safe containers.
- Keep electrostatic-sensitive parts in their containers until they arrive at static-free workstations.
- Place parts on a grounded surface before removing them from their containers.
- Avoid touching pins, leads, or circuitry.
- Always be properly grounded when touching a static-sensitive component or assembly. Use one or more of the following methods when handling or installing electrostatic-sensitive parts:
 - Use a wrist strap connected by a ground cord to a grounded workstation or computer chassis. Wrist straps are flexible straps with a minimum of 1 megohm \pm 10 percent resistance in the ground cords. To provide proper ground, wear the strap snug against the skin.
 - Use heel straps, toe straps, or boot straps at standing workstations. Wear the straps on both feet when standing on conductive floors or dissipating floor mats.
 - Use conductive field service tools.
 - Use a portable field service kit with a folding static-dissipating work mat.

If you do not have any of the suggested equipment for proper grounding, have an authorized reseller install the part.

For more information on static electricity or assistance with product installation, contact an authorized reseller.

Symbols on equipment

The following symbols might be found on the equipment to indicate the presence of potentially hazardous conditions.

 **WARNING:**



This symbol indicates the presence of hazardous energy circuits or electric shock hazards. Refer all servicing to qualified personnel.

To reduce the risk of injury from electric shock hazards, do not open this enclosure. Refer all maintenance, upgrades, and servicing to qualified personnel.

 **WARNING:**



This symbol indicates the presence of electric shock hazards. The area contains no user or field serviceable parts. Do not open for any reason.

To reduce the risk of injury from electric shock hazards, do not open this enclosure.

 **WARNING:**



This symbol on an RJ-45 receptacle indicates a network interface connection.

To reduce the risk of electric shock, fire, or damage to the equipment, do not plug telephone or telecommunications connectors into this receptacle.

 **WARNING:**



This symbol indicates the presence of a hot surface or hot component. If this surface is contacted, the potential for injury exists.

To reduce the risk of injury from a hot component, allow the surface to cool before touching.

 **WARNING:**



This symbol indicates that the component exceeds the recommended weight for one individual to handle safely.

To reduce the risk of personal injury or damage to the equipment, observe local occupational health and safety requirements and guidelines for manual material handling.

 **WARNING:**



These symbols, on power supplies or systems, indicate that the equipment is supplied by multiple sources of power.

To reduce the risk of injury from electric shock, remove all power cords to disconnect power from the system completely.

Rack warnings and cautions

 **WARNING:**

When all components are removed, the server weighs 0. When all components are installed, the server can weigh up to 0.

Before configuring your rack solution, be sure to check the rack manufacturer weight limits and specifications. Failure to do so can result in physical injury or damage to the equipment and the facility.

 **WARNING:**

The server is heavy. To reduce the risk of personal injury or damage to the equipment, do the following:

- Observe local occupational health and safety requirements and guidelines for manual material handling.
 - Get help to lift and stabilize the product during installation or removal, especially when the product is not fastened to the rails. The server weighs more than 0, so at least two people must lift the server into the enclosure together. An additional person may be required to help align the server if the server is installed higher than chest level.
 - Use caution when installing the server in or removing the server from the enclosure.
 - Adequately stabilize the enclosure before extending a component outside the enclosure. Extend only one component at a time. An enclosure may become unstable if more than one component is extended.
 - Do not stack anything on top of rail-mounted component or use it as a work surface when extended from the rack.
-

 **WARNING:**

To reduce the risk of personal injury or damage to the equipment, be sure that:

- The rack has anti-tip measures in place. Such measures include floor-bolting, anti-tip feet, ballast, or a combination as specified by the rack manufacturer and applicable codes.
 - The leveling jacks (feet) are extended to the floor.
 - The full weight of the rack rests on the leveling jacks (feet).
 - The stabilizing feet are attached to the rack if it is a single-rack installation.
 - The racks are coupled together in multiple rack installations.
-

 **WARNING:**

To reduce the risk of personal injury or equipment damage when unloading a rack:

- At least two people are needed to safely unload the rack from the pallet. An empty 42U rack can weigh as much as 115 kg (253 lb), can stand more than 2.1 m (7 ft) tall, and might become unstable when being moved on its casters.
 - Never stand in front of the rack when it is rolling down the ramp from the pallet. Always handle the rack from both sides.
-

△ CAUTION:

Always plan the rack installation so that the heaviest item is on the bottom of the rack. Install the heaviest item first, and continue to populate the rack from the bottom to the top.

△ CAUTION:

Before installing the server in a enclosure, be sure to properly scope the limitations of the enclosure. Before proceeding with the installation, consider the following:

- You must fully understand the static and dynamic load carrying capacity of the enclosure and be sure that it can accommodate the weight of the server .
 - Be sure sufficient clearance exists for cabling, installation and removal of the server , and movement of the rack doors.
-

Server warnings and cautions

Before installing a server, be sure that you understand the following warnings and cautions.

⚠ WARNING: To reduce the risk of electric shock, personal injury, and damage to the equipment:

- Do not attempt to service any parts of the equipment other than those specified in the following procedure. Any other activities may require that you shut down the server and remove the power cord.
 - Installation and maintenance of this product must be performed by individuals who are knowledgeable about the procedures, precautions, and hazards associated with the product.
-

⚠ WARNING: To reduce the risk of personal injury from hot surfaces, allow the drives and the internal system components to cool before touching them.

⚠ WARNING:

To reduce the risk of fire or burns after removing the energy pack:

- Do not disassemble, crush, or puncture the energy pack.
- Do not short external contacts.
- Do not dispose of the energy pack in fire or water.
- Do not expose the energy pack to low air pressure as it might lead to explosion or leakage of flammable liquid or gas.
- Do not expose the energy pack to temperatures higher than 60°C (140°F).

After power is disconnected, battery voltage might still be present for 1s to 160s.

⚠ CAUTION: Do not operate the server for long periods with the access panel open or removed. Operating the server in this manner results in improper airflow and improper cooling that can lead to thermal damage.

Preparation procedures

Accessing the Systems Insight Display

The Systems Insight Display is supported only on SFF models.

Procedure

1. Press and release the panel.

2. After the display fully ejects, rotate the display to view the LEDs.

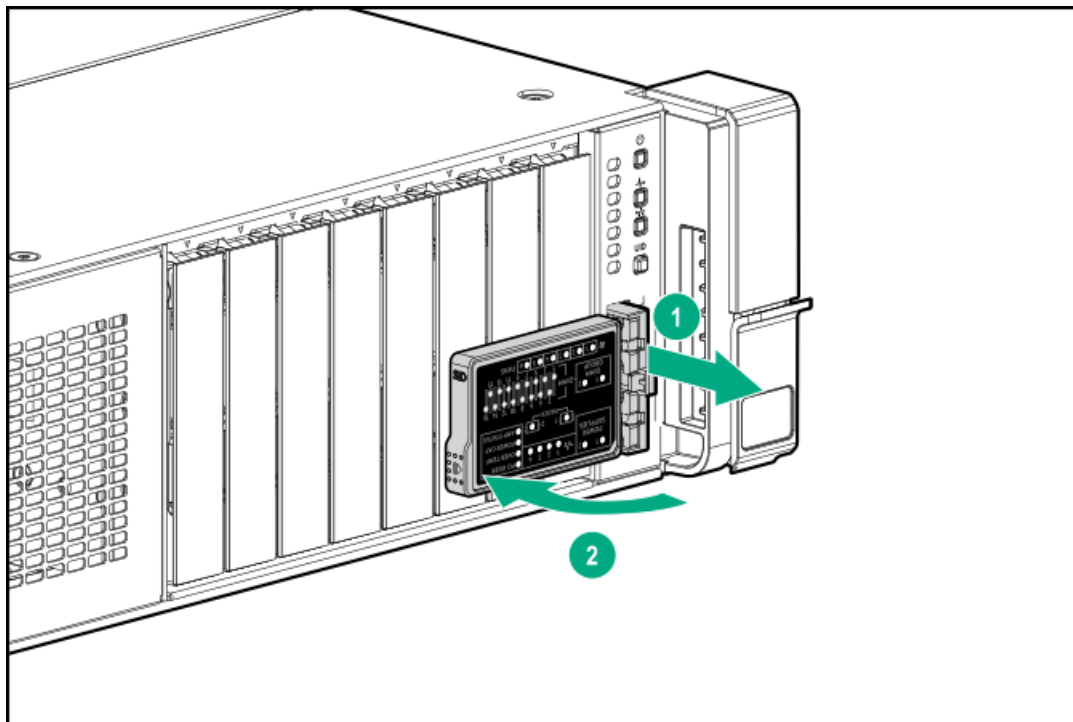

Power down the server

Before powering down the server for any upgrade or maintenance procedures, perform a backup of critical server data and programs.

ⓘ IMPORTANT:

When the server is in standby mode, auxiliary power is still being provided to the system.

To power down the server, use one of the following methods:

- Press and release the Power On/Standby button.
This method initiates a controlled shutdown of applications and the OS before the server enters standby mode.
- Press and hold the Power On/Standby button for more than 4 seconds to force the server to enter standby mode.
This method forces the server to enter standby mode without properly exiting applications and the OS. If an application stops responding, you can use this method to force a shutdown.
- Use a virtual power button selection through iLO.
This method initiates a controlled remote shutdown of applications and the OS before the server enters standby mode.

Before proceeding, verify that the server is in standby mode by observing that the system power LED is amber.

Extend the server from the rack

1. Pull down the quick release levers on each side of the server.
2. If necessary, use a T-25 Torx screwdriver to loosen the shipping screws.
3. Extend the server from the rack.

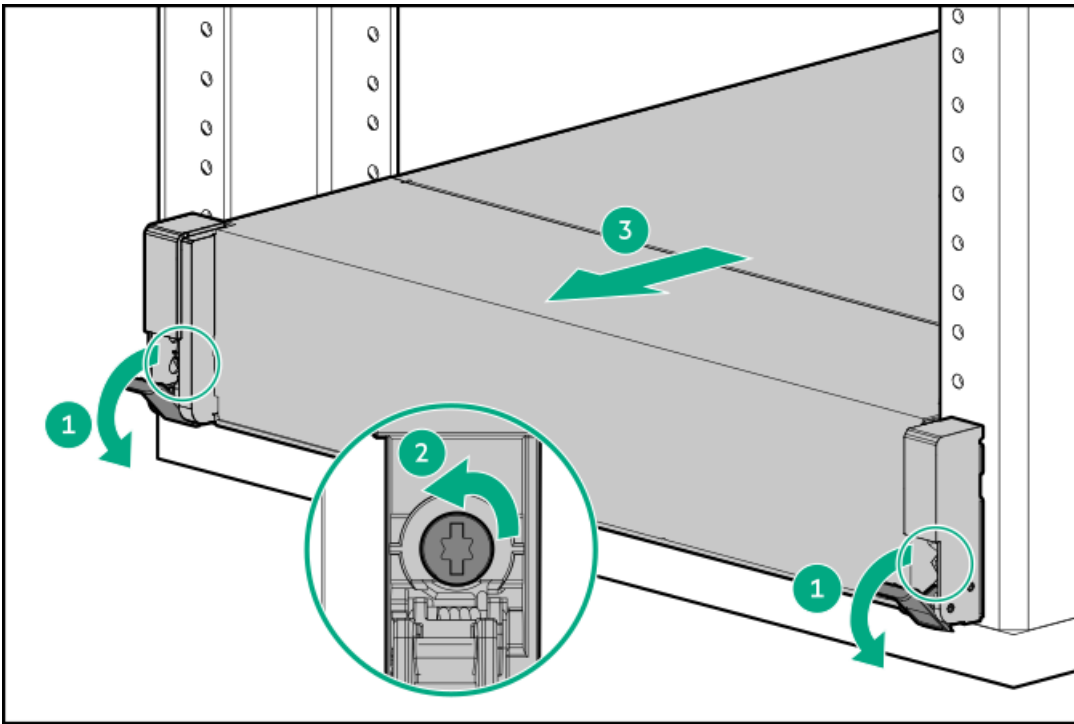

4. After performing the installation or maintenance procedure, slide the server back into the rack, and then press the server firmly into the rack to secure it in place.

⚠ WARNING:

To reduce the risk of personal injury, be careful when pressing the server rail-release latches and sliding the server into the rack. The sliding rails could pinch your fingers.

Remove the server from the rack

To remove the server from a Hewlett Packard Enterprise, Compaq-branded, Telco, or third-party rack, complete the following.

Procedure

1. Power down the server .
2. Extend the server from the rack.
3. Disconnect the cabling and remove the server from the rack.

For more information, see the documentation that ships with the rack mounting option.

4. Place the server on a sturdy, level surface.

Releasing the cable management arm

Release the cable management arm and then swing the arm away from the rack.

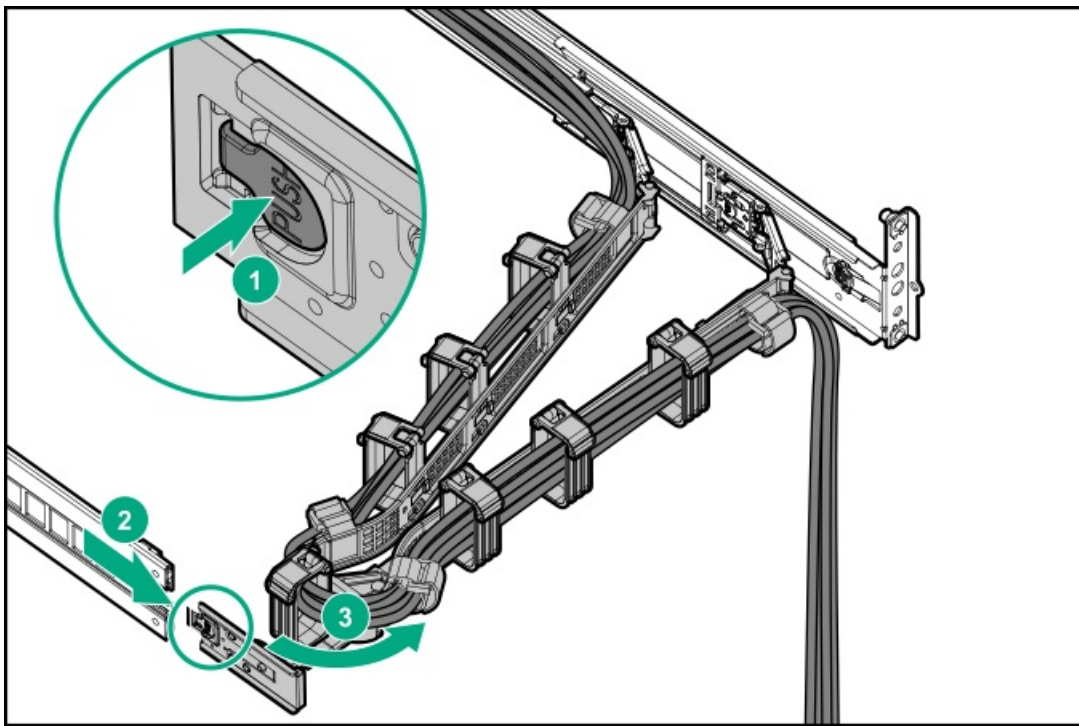

Remove the access panel

WARNING: To reduce the risk of personal injury from hot surfaces, allow the drives and the internal system components to cool before touching them.

CAUTION: Do not operate the server for long periods with the access panel open or removed. Operating the server in this manner results in improper airflow and improper cooling that can lead to thermal damage.

Procedure

1. Power down the server.
2. Extend the server from the rack.
3. Open or unlock the locking latch, slide the access panel to the rear of the chassis, and remove the access panel.

Removing the air baffle

CAUTION: Do not detach the cable that connects the battery pack to the cache module. Detaching the cable causes any unsaved data in the cache module to be lost.

CAUTION: For proper cooling, do not operate the server without the access panel, baffles, expansion slot covers, or blanks installed. If the server supports hot-plug components, minimize the amount of time the access panel is open.

Procedure

1. Power down the server.
2. Remove all power:
 - a. Disconnect each power cord from the power source.

- b. Disconnect each power cord from the server.
3. Do one of the following:
 - Extend the server from the rack.
 - Remove the server from the rack.
4. Remove the access panel.
5. Remove the air baffle.

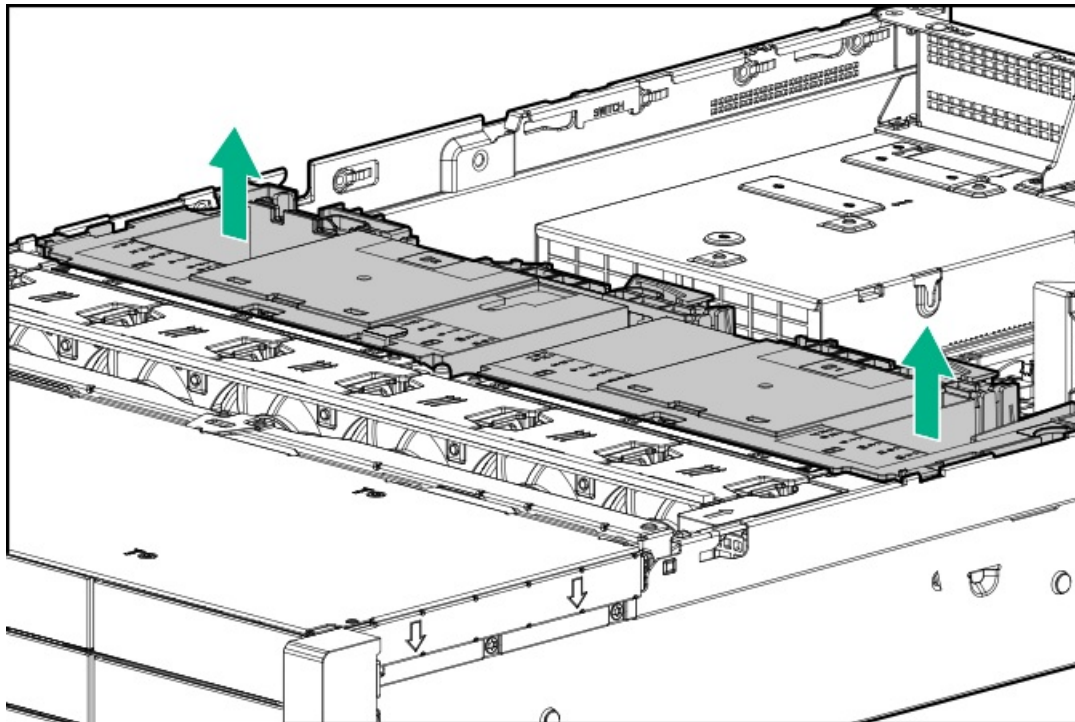

Release the full-length expansion board retainer

Procedure

1. Power down the server.
2. Remove all power:
 - a. Disconnect each power cord from the power source.
 - b. Disconnect each power cord from the server.
3. Do one of the following:
 - Extend the server from the rack.
 - Remove the server from the rack.
4. Remove the access panel.
5. Remove the air baffle.
6. Release the full-length expansion board retainer.

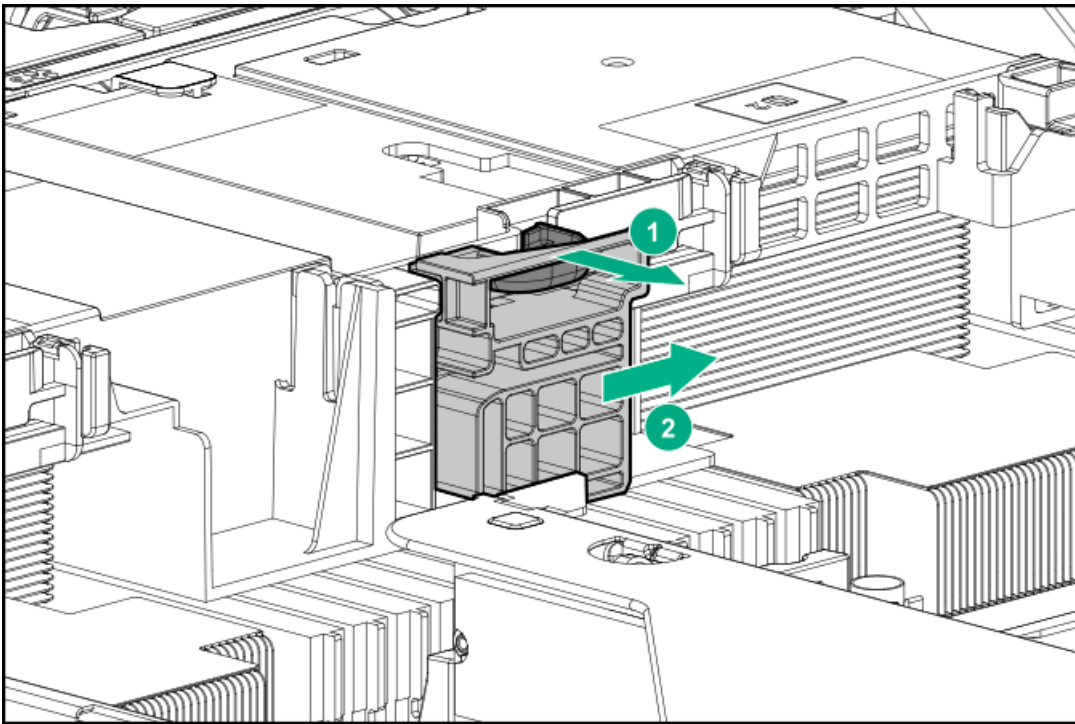

To replace the component, reverse the removal procedure.

Removing and replacing the rack rails

⚠ WARNING:

To reduce the risk of personal injury or damage to the equipment, you must adequately support the enclosure during installation and removal.

Prerequisites

Before you begin, be sure that you have the appropriate screwdriver for the screws in the rack.

Procedure

1. Power down the server.
2. Remove all power:
 - a. Disconnect each power cord from the power source.
 - b. Disconnect each power cord from the server.
3. Remove the server from the rack.
4. Place the server on a sturdy, level surface.

i IMPORTANT:

When removing the rail from the rack, always remove the front of the rail first.

5. Remove the rail from the rack.

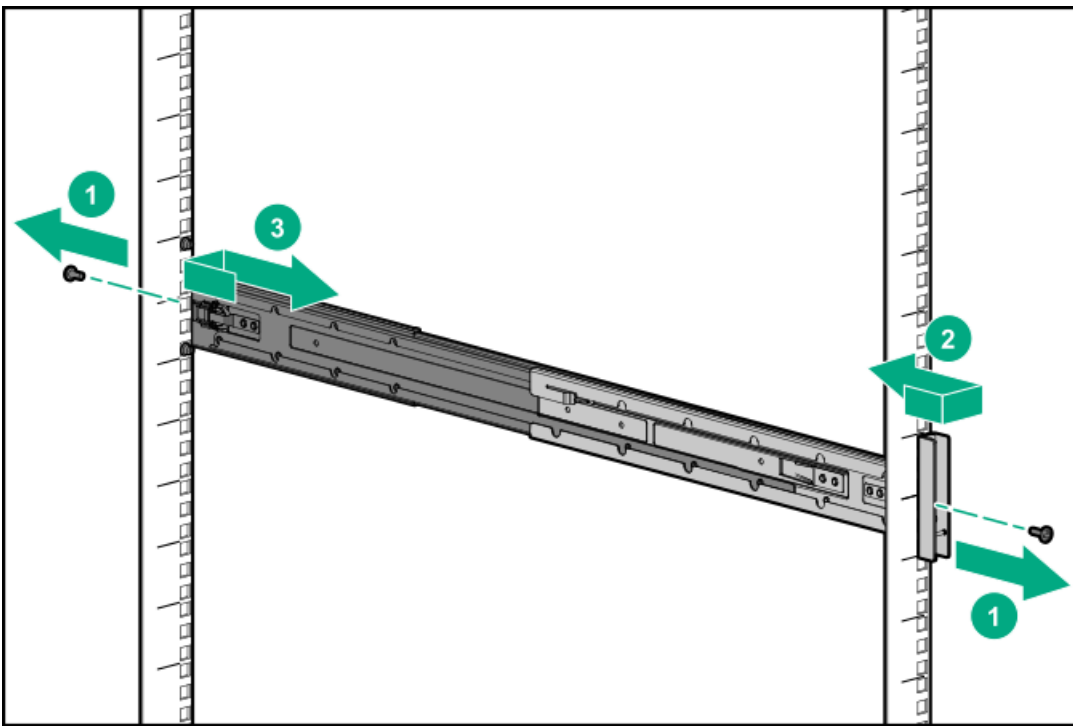

To replace the component, reverse the removal procedure.

Removing and replacing the cable management arm

Procedure

1. Power down the server.
2. Remove all power:
 - a. Disconnect each power cord from the power source.
 - b. Disconnect each power cord from the server.
3. Extend the server from the rack.
4. Remove the cables from the cable management arm.

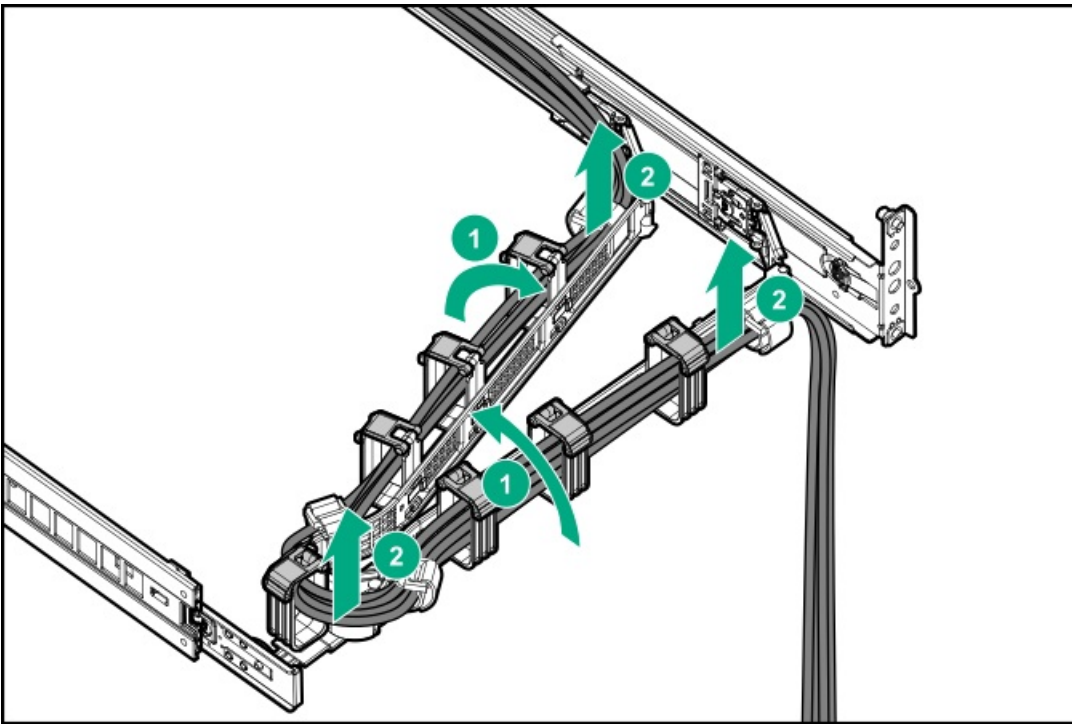

5. Remove the cable management arm.

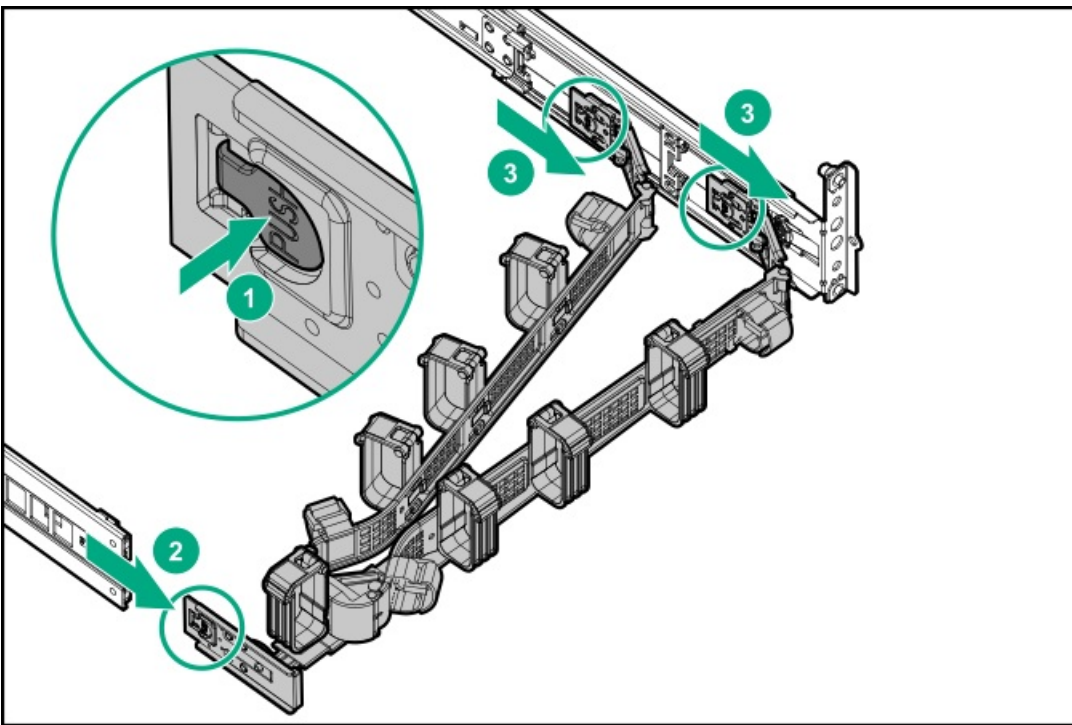

To replace the component, reverse the removal procedure.

Removing and replacing the front bezel

Procedure

1. If installed, remove the Kensington security lock.



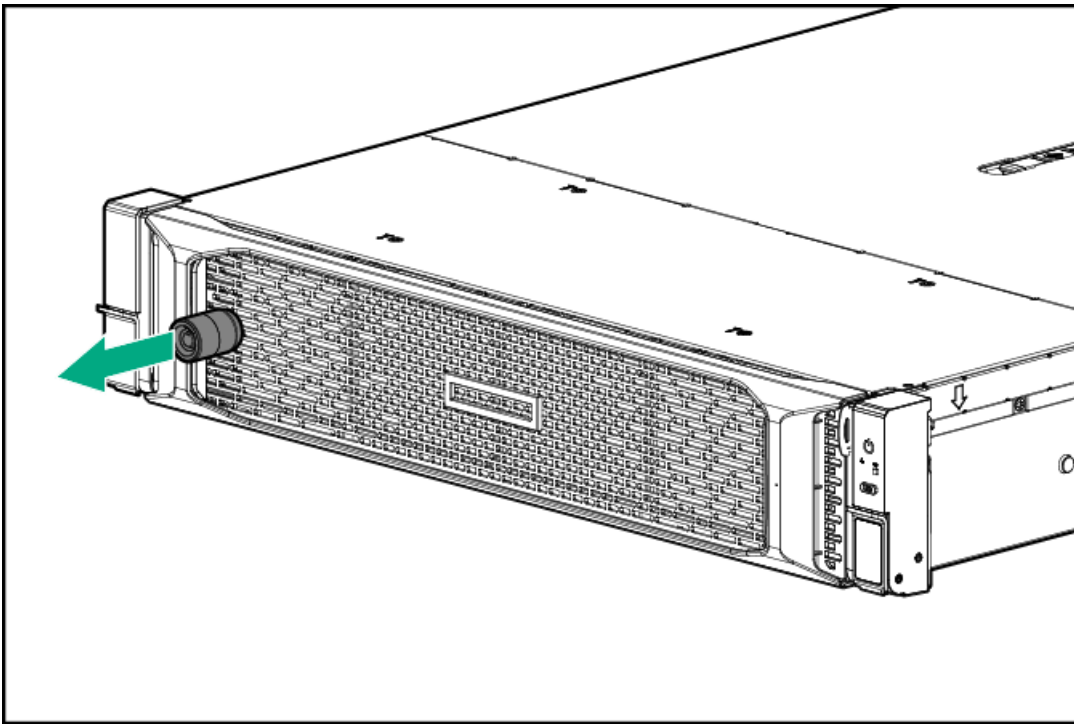

2. Remove the front bezel.

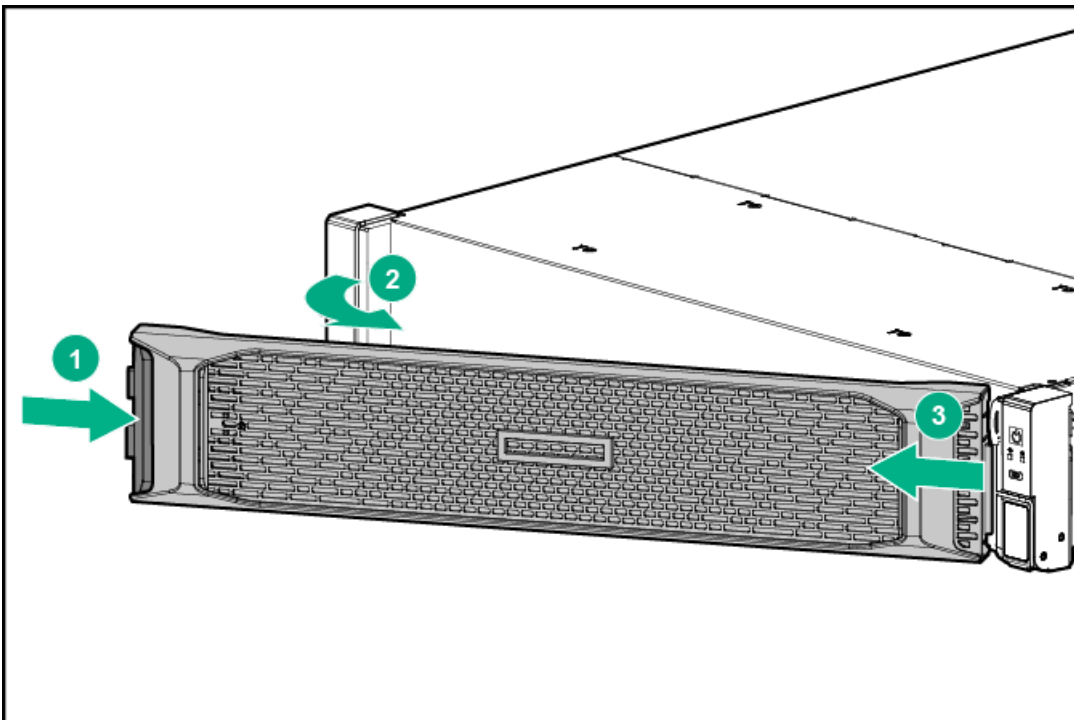

To replace the component, reverse the removal procedure.

Removing and replacing a drive blank

CAUTION: To prevent improper cooling and thermal damage, do not operate the server unless all bays are populated with either a component or a blank.

Procedure

1. If installed, remove the front bezel.
2. Remove the drive blank.

- LFF drive blank

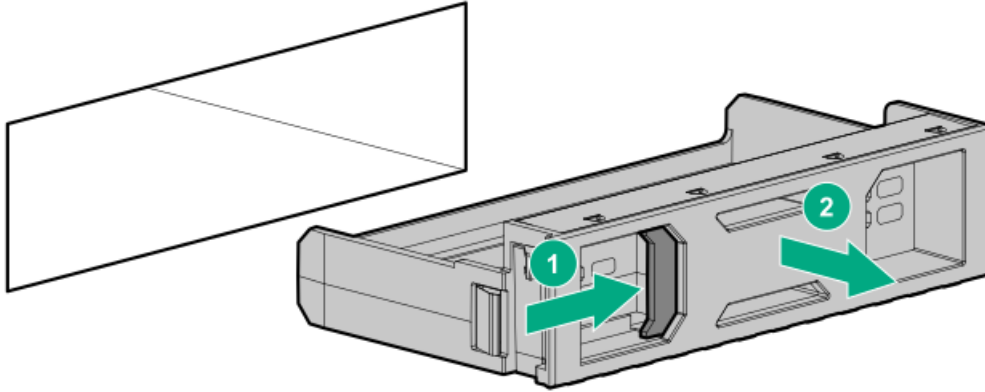

- SFF drive blank

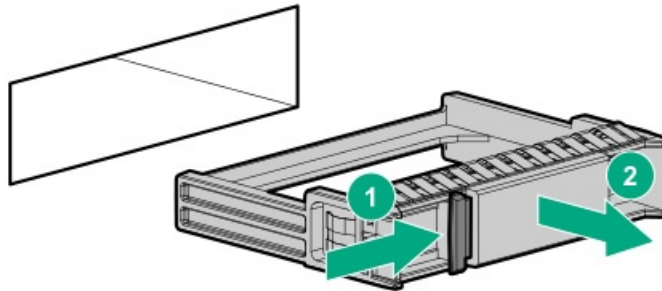

To replace the component, reverse the removal procedure.

Removing and replacing a hot-plug SAS, SATA or NVMe drive

CAUTION: To prevent improper cooling and thermal damage, do not operate the server unless all bays are populated with either a component or a blank.

Procedure

1. Back up all server data on the drive.
2. If installed, remove the front bezel.
3. Observe the drive LED status and determine if it can be removed.
4. Remove the drive.

- LFF drive

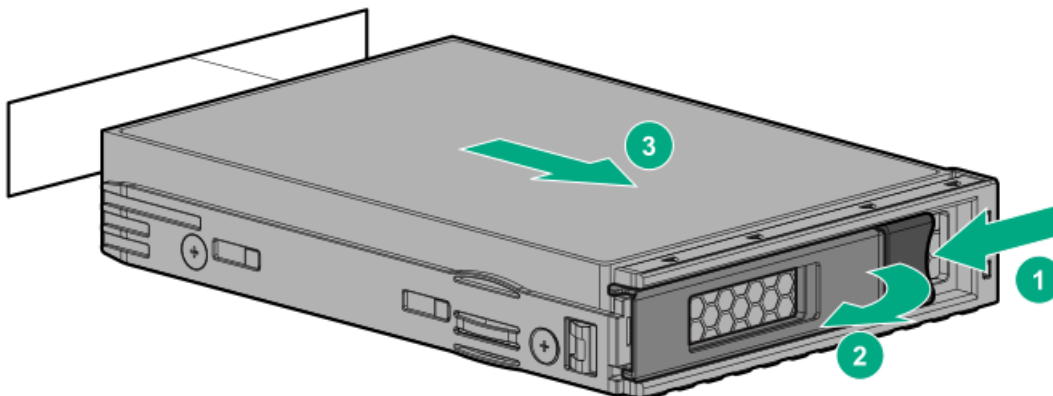

- SFF drive

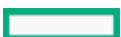

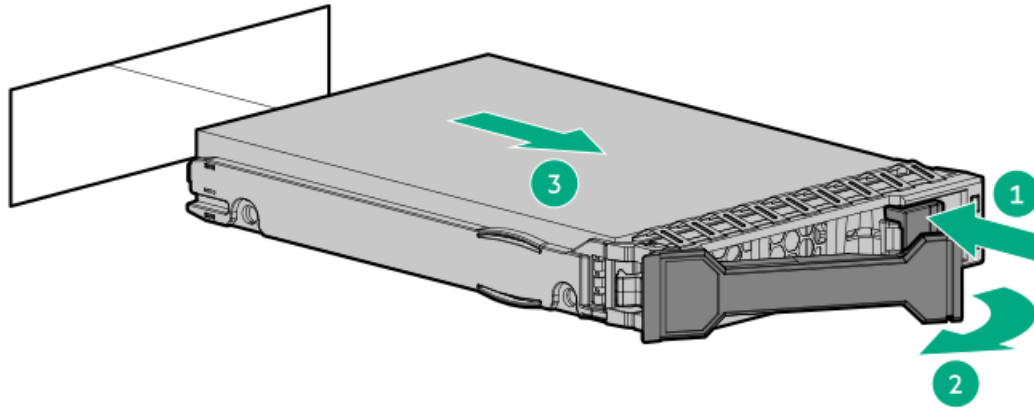

To replace the component, reverse the removal procedure.

Removing and replacing the hot-plug fan

Procedure

1. Extend the server from the rack ([Extend the server from the rack](#)).
2. Remove the access panel ([Remove the access panel](#)).

⚠ CAUTION: Do not operate the server for long periods with the access panel open or removed. Operating the server in this manner results in improper airflow and improper cooling that can lead to thermal damage.

ⓘ IMPORTANT: For optimum cooling, install fans in all primary fan locations.

For more information, refer to the fan locations table in the server user guide.

3. Remove the fan.

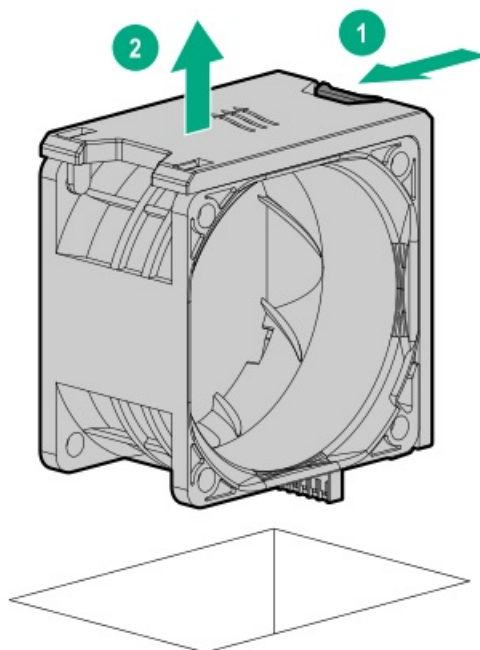

To replace the component, reverse the removal procedure.

Removing and replacing the fan cage

Procedure

1. [Power down the server.](#)
2. Remove all power:
 - a. Disconnect each power cord from the power source.
 - b. Disconnect each power cord from the server.
3. Do one of the following:
 - [Extend the server from the rack.](#)
 - [Remove the server from the rack.](#)
4. [Remove the access panel.](#)

△ CAUTION: Do not operate the server for long periods with the access panel open or removed. Operating the server in this manner results in improper airflow and improper cooling that can lead to thermal damage.

5. Remove the fan cage.

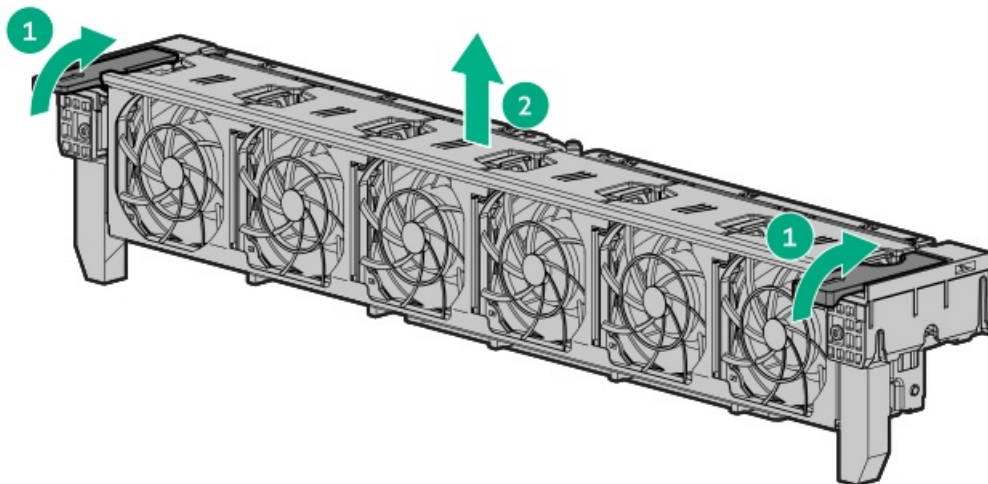

i IMPORTANT: For optimum cooling, install fans in all primary fan locations.

For more information, see [Fan bay numbering.](#)

To replace the component, reverse the removal procedure.

Removing and replacing a power supply blank

⚠ WARNING: To reduce the risk of personal injury from hot surfaces, allow the power supply or power supply blank to cool before touching it.

△ CAUTION: To prevent improper cooling and thermal damage, do not operate the server unless all bays are populated with either a component or a blank.

Procedure

1. Remove the power supply blank.

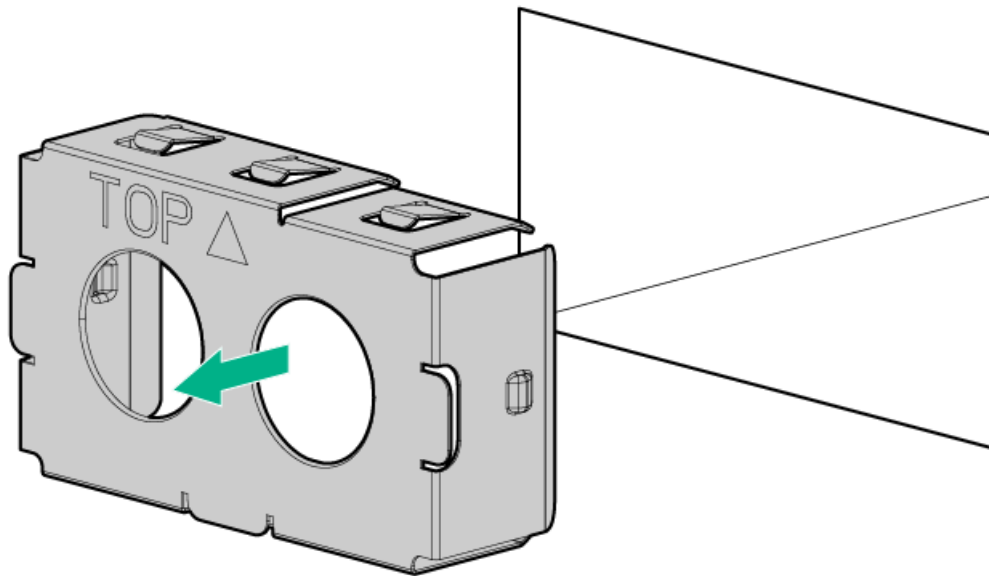

2. Immediately install the replacement power supply blank spare.

Removing and replacing a hot-plug AC power supply

⚠ WARNING:

To reduce the risk of personal injury, fire, or damage to the equipment, do not overload the AC supply branch circuit that provides power to the rack. Consult the electrical authority having jurisdiction over wiring and installation requirements of your facility.

⚠ WARNING: To reduce the risk of personal injury from hot surfaces, allow the drives, power supplies, and internal system components to cool before touching them.

⚠ CAUTION: To prevent damage to electrical components, properly ground the server before beginning any installation procedure. Improper grounding can cause electrostatic discharge.

⚠ CAUTION:

To prevent improper cooling and thermal damage, do not operate the server or the enclosure unless all drive and device bays are populated with either a component or a blank.

Procedure

1. If installed, release the cable management arm.
2. If the server is using a single power supply only, remove all power from the server:
 - a. Back up all server data.
 - b. Power down the server.
 - c. Disconnect all peripheral cables from the server.
3. Release the power cord from the strain relief strap.

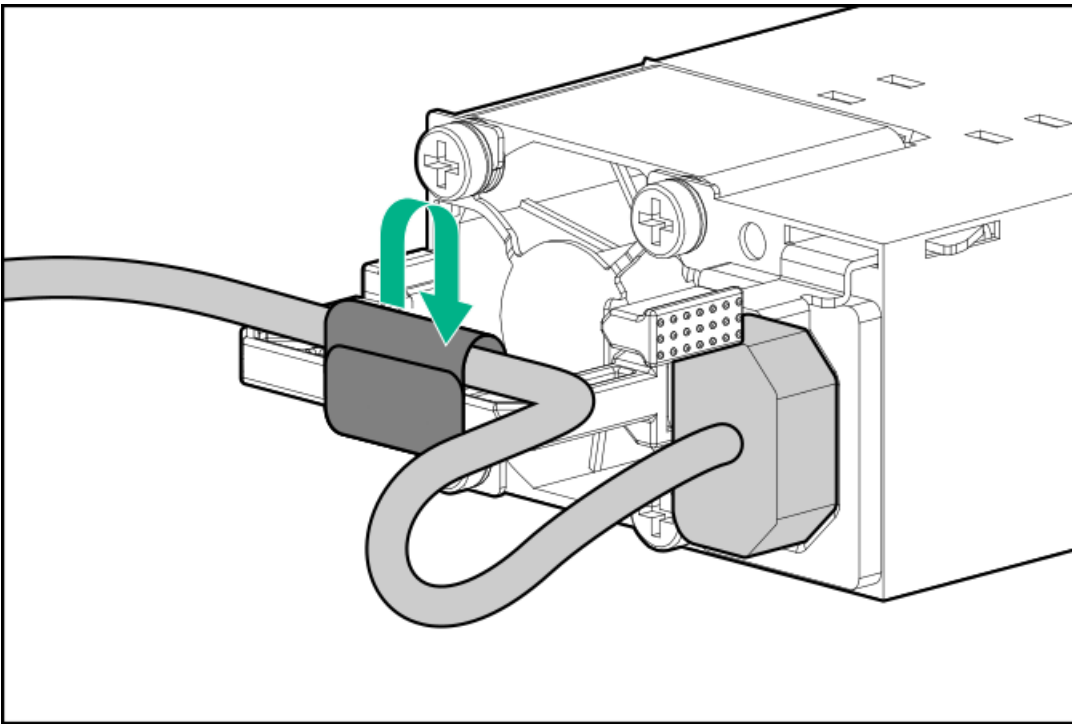

4. Disconnect the power cord from the power supply.

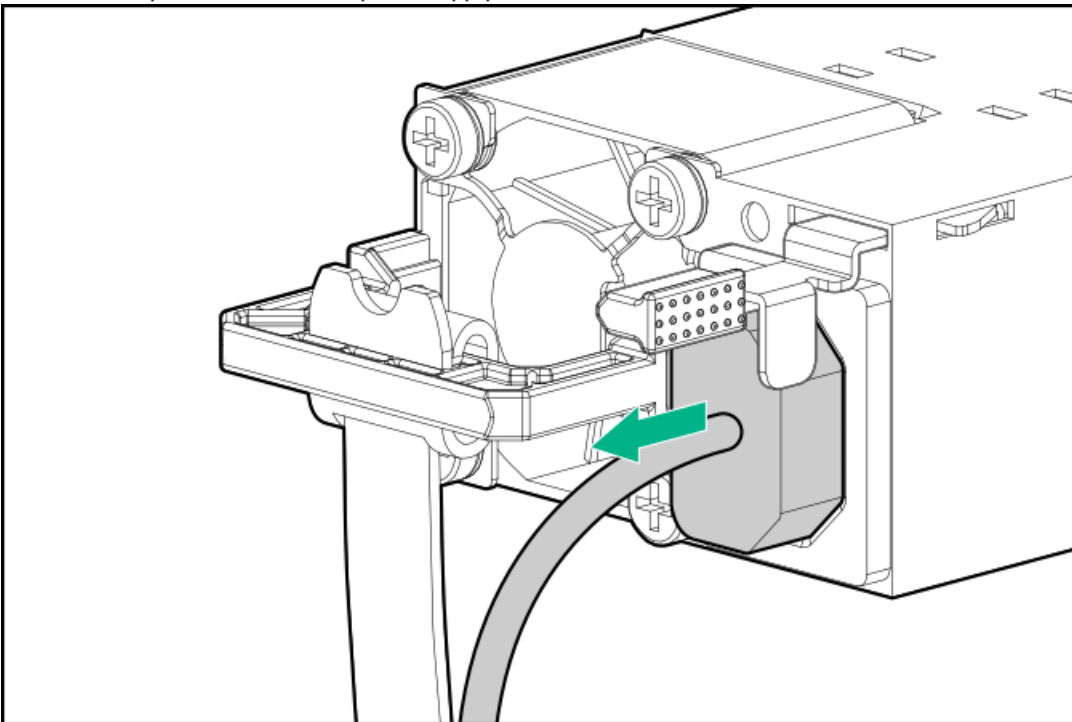

5. Remove the power supply.

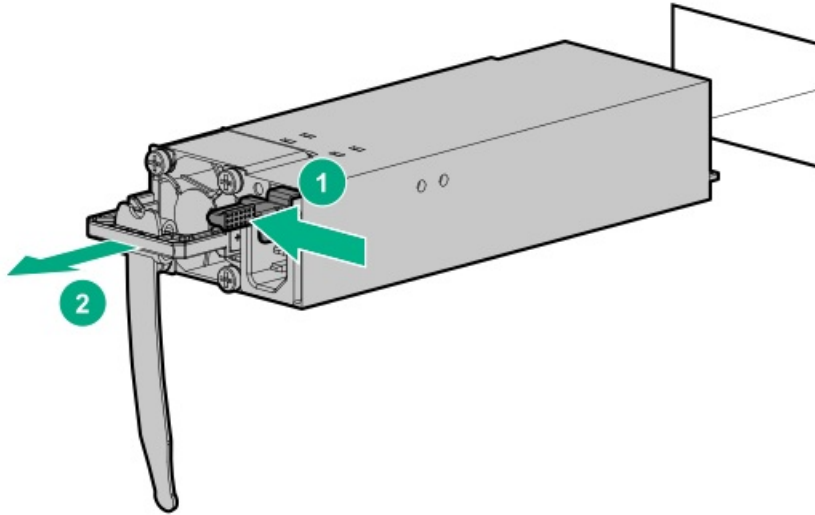

To replace the component, reverse the removal procedure.

Removing and replacing the HPE 800 W Flex Slot -48 VDC hot-plug power supply

⚠ WARNING:

To reduce the risk of electric shock, fire, and damage to the equipment, you must install this product in accordance with the following guidelines:

- The HPE 800 W Flex Slot -48 VDC hot-plug power supply is intended only for installation in Hewlett Packard Enterprise servers located in a restricted access location.
- The HPE 800 W Flex Slot -48 VDC hot-plug power supply is not intended for direct connection to the DC supply branch circuit. Only connect this power supply to a power distribution unit (PDU) that provides an independent overcurrent-protected output for each DC power supply. Each output overcurrent-protected device in the PDU must be suitable for interrupting fault current available from the DC power source and must be rated no more than 30 A.
- The PDU output must have a shut-off switch or a circuit breaker to disconnect power for each power supply. To completely remove power from the power supply, disconnect power at the PDU. Disconnect the power for each power supply, if there are multiple power supplies.
- In accordance with applicable national requirements for Information Technology Equipment and Telecommunications Equipment, this power supply only connects to DC power sources that are classified as SELV or TNV. Generally, these requirements are based on the International Standard for Information Technology Equipment, IEC 60950-1/IEC 62368-1. In accordance with local and regional electric codes and regulations, the DC source must have one pole (Neutral/Return) reliably connected to earth ground.
- You must connect the power supply ground screw located on the front of the power supply to a suitable ground (earth) terminal. In accordance with local and regional electric codes and regulations, this terminal must be connected to a suitable building ground (earth) terminal. Do not rely on the rack or cabinet chassis to provide adequate ground (earth) continuity.

Prerequisites

Before you perform this procedure, make sure that you have the following items:

- No. 1 Phillips screwdriver
- If you are replacing the factory installed ground lug, use the KST RNB5-5 crimp terminal ring or equivalent. Use an M5-0.80 x 8 screw to attach the ground lug to the power supply.

Procedure

1. If installed, release the cable management arm.
2. If the server is using a single power supply only, remove all power from the server:
 - a. Back up all server data.
 - b. Power down the server.
 - c. Disconnect all peripheral cables from the server.
3. Release the power cord, wires, and/or cables from the strain relief strap.
4. To access the ground cable screw, slide the power supply out of the bay.

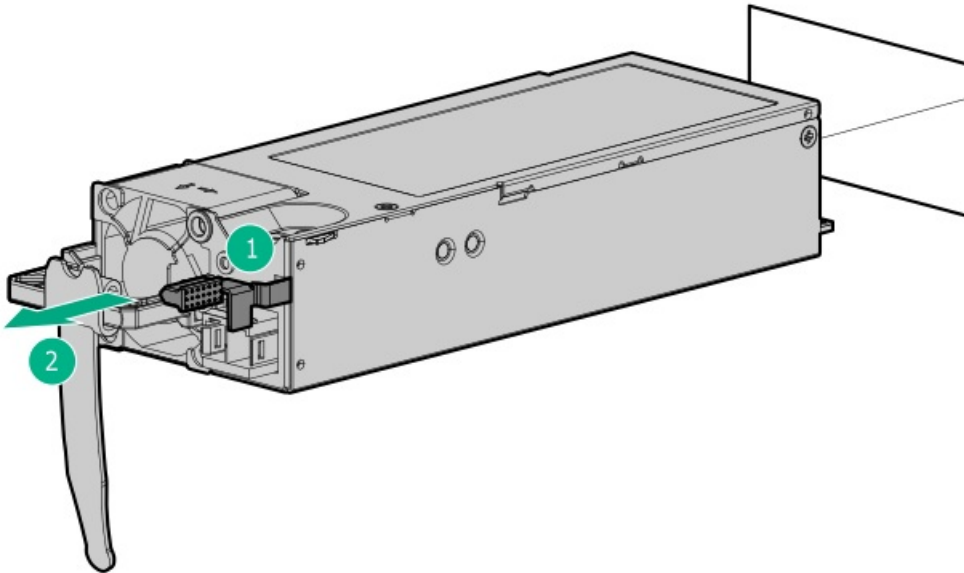

5. Detach the ground (earthed) cable from the power supply.

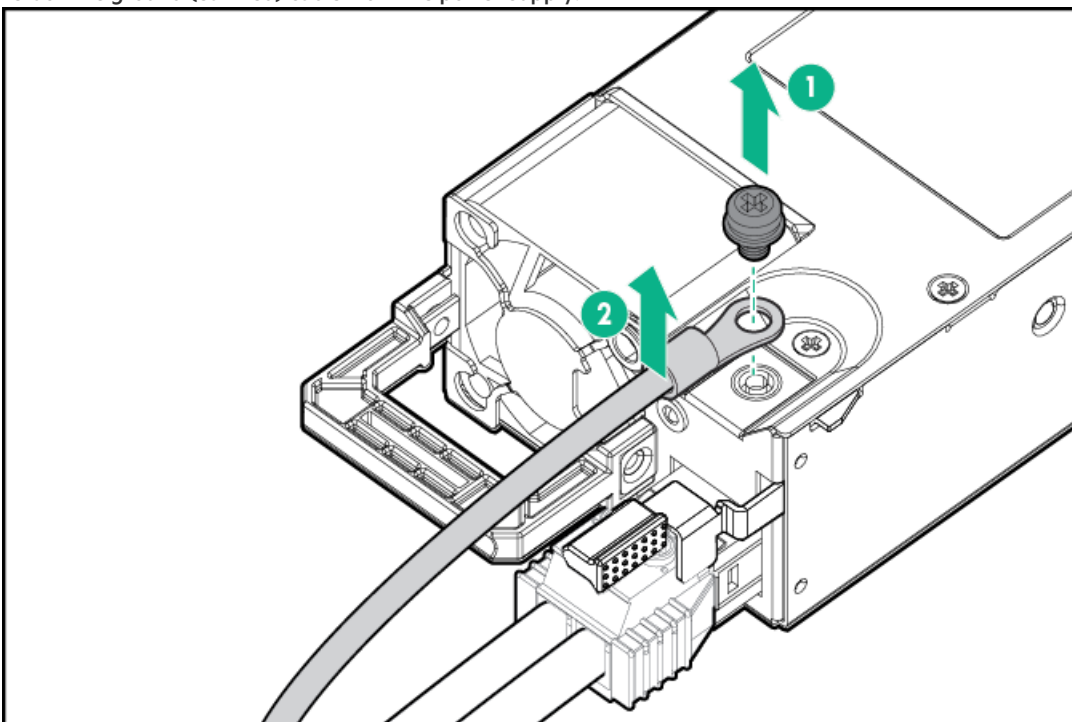

6. Remove the terminal block connector from the power supply.



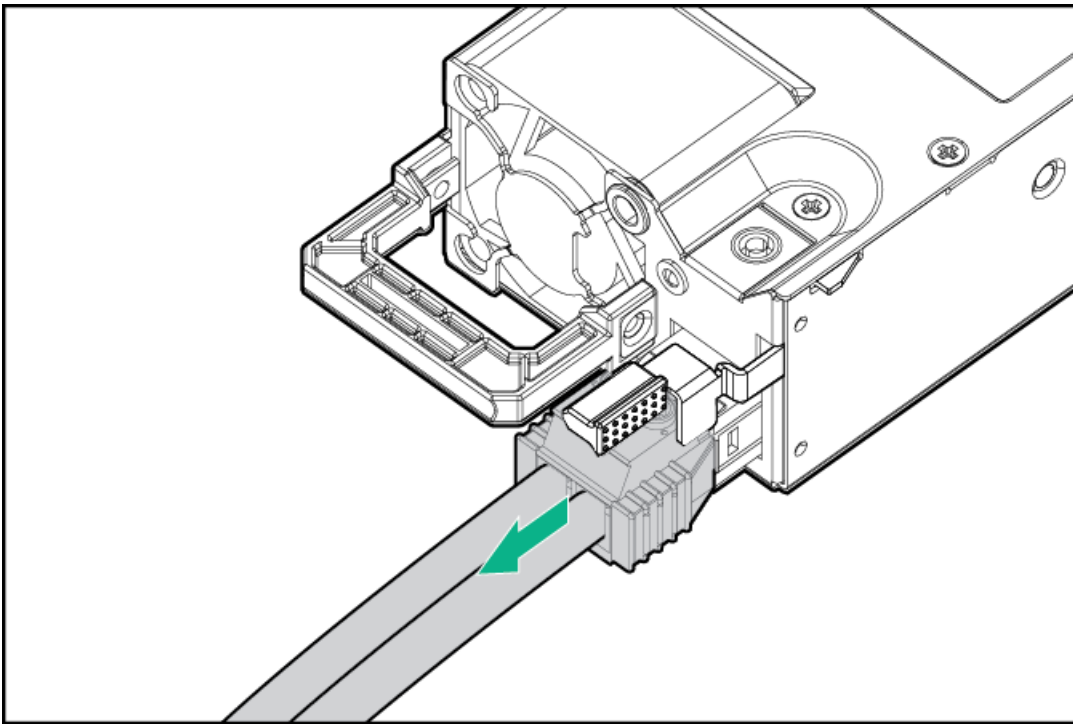

To replace the component, reverse the removal procedure.

Removing and replacing an HPE 1600 W Flex Slot -48 VDC hot-plug power supply

⚠ WARNING:

To reduce the risk of electric shock, fire, and damage to the equipment, you must install this product in accordance with the following guidelines:

- The HPE 1600 W Flex Slot -48 VDC hot-plug power supply is intended only for installation in Hewlett Packard Enterprise servers located in a restricted access location.
- The HPE 1600 W Flex Slot -48 VDC hot-plug power supply is not intended for direct connection to the DC supply branch circuit. Only connect this power supply to a power distribution unit (PDU) that provides an independent overcurrent-protected output for each DC power supply. Each output overcurrent-protected device in the PDU must be suitable for interrupting fault current available from the DC power source and must be rated no more than 45 A.
- The PDU output must have a shut-off switch or a circuit breaker to disconnect power for each power supply. To completely remove power from the power supply, disconnect power at the PDU. The end product may have multiple power supplies. To remove all power from the product, disconnect the power for each power supply.
- In accordance with applicable national requirements for Information Technology Equipment and Telecommunications Equipment, this power supply only connects to DC power sources that are classified as SELV or TNV. Generally, these requirements are based on the International Standard for Information Technology Equipment, IEC 60950-1/IEC 62368-1. In accordance with local and regional electric codes and regulations, the DC source must have one pole (Neutral/Return) reliably connected to earth ground.
- You must connect the power supply ground screw located on the front of the power supply to a suitable ground (earth) terminal. In accordance with local and regional electric codes and regulations, this terminal must be connected to a suitable building ground (earth) terminal. Do not rely on the rack or cabinet chassis to provide adequate ground (earth) continuity.

Prerequisites

Before you perform this procedure, make sure that you have a No. 1 Phillips screwdriver.

Procedure

1. If installed, release the cable management arm.
2. If the server is using a single power supply only, remove all power from the server:
 - a. Back up all server data.
 - b. Power down the server.
 - c. Disconnect all peripheral cables from the server.
3. Slide the power supply out of the bay.
4. Release the ground (earthed), -48 V, and return wires from the strain relief strap.

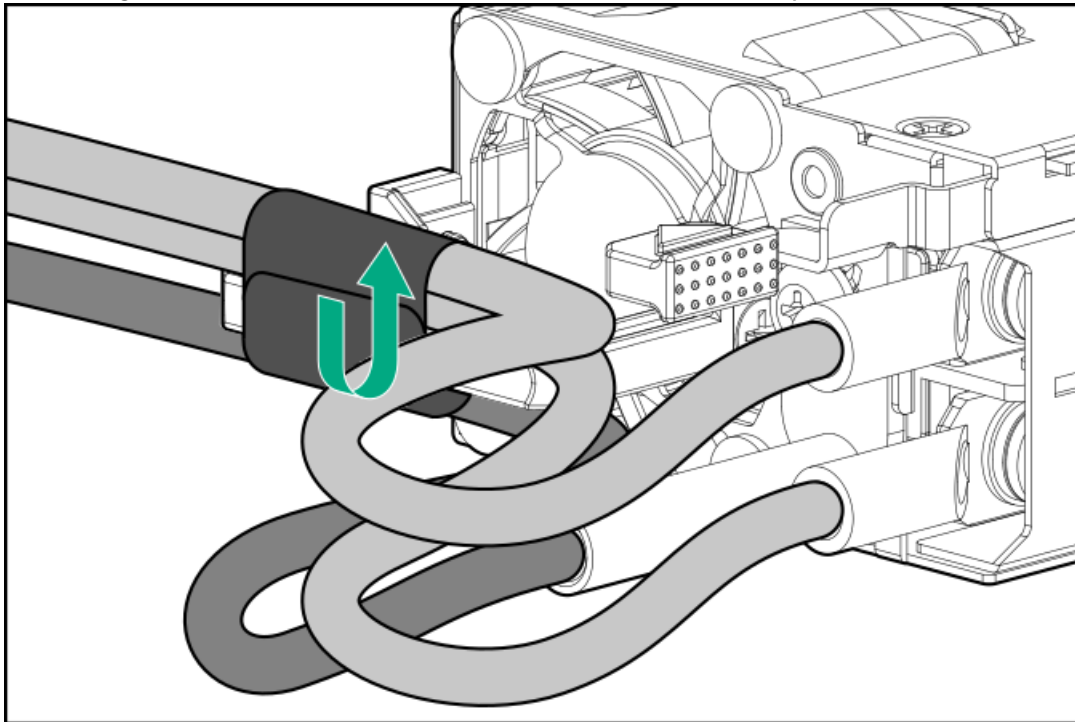

5. Disconnect the ground (earthed) wire from the power supply.

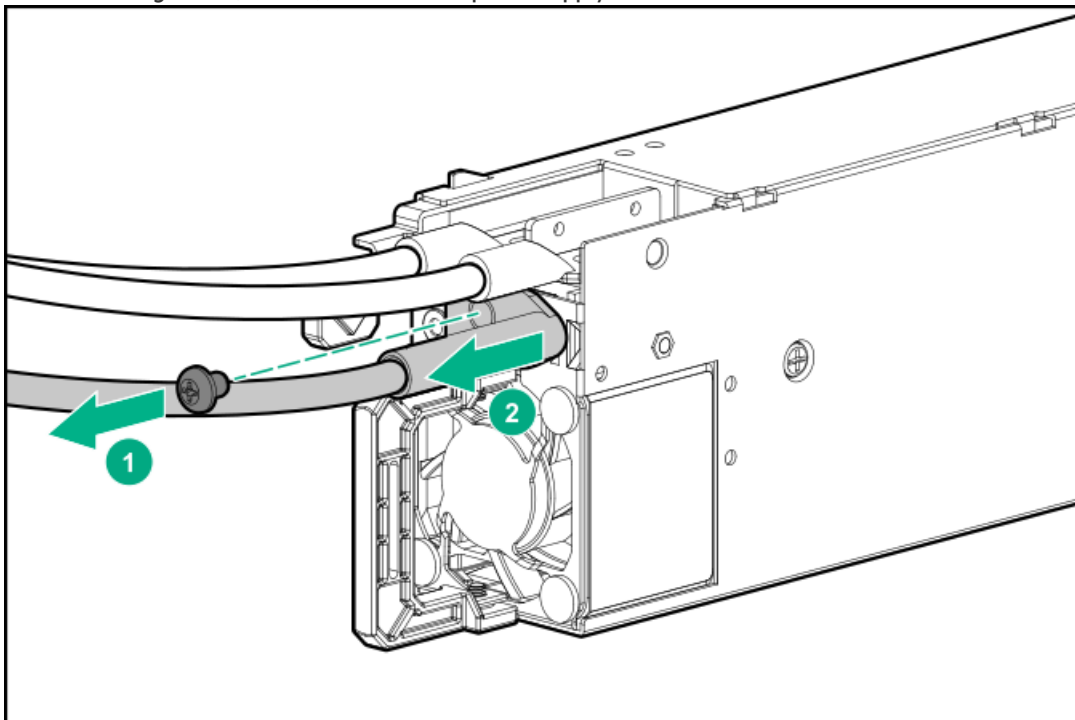

6. Remove the clear plastic cover from the power supply.



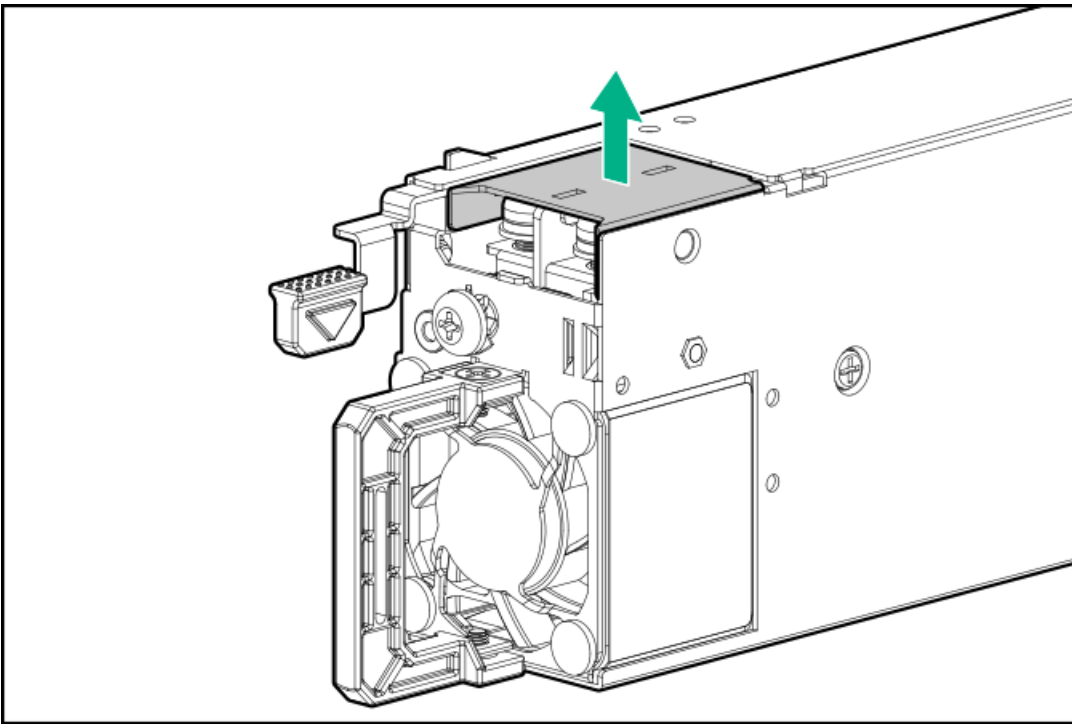

7. Disconnect the -48 V and return wires from the power supply.

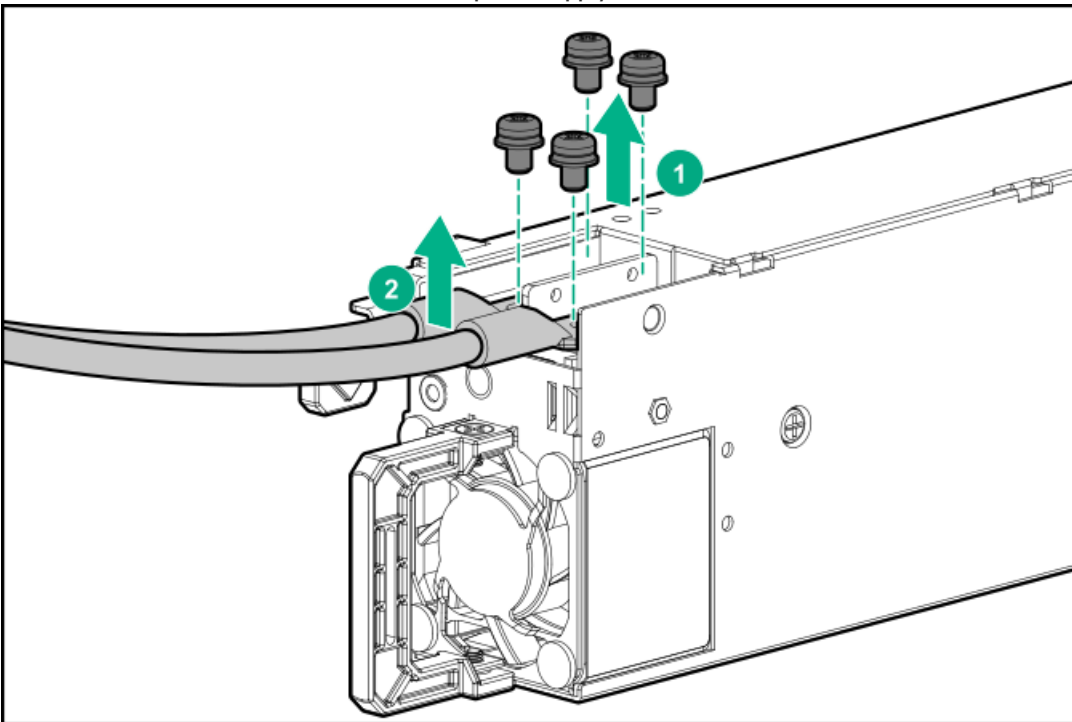

To replace the component, reverse the removal procedure.

Removing and replacing the primary PCIe riser cage

CAUTION: To prevent improper cooling or thermal damage, the server PCI slots must have an expansion slot blank or an expansion board installed.

Procedure

1. Power down the server.
2. Remove all power:
 - a. Disconnect each power cord from the power source.
 - b. Disconnect each power cord from the server.
3. Disconnect any external cables that are connected to the expansion board.
4. Do one of the following:
 - Extend the server from the rack.
 - Remove the server from the rack.
5. Remove the access panel.
6. Disconnect any internal cables that are connected to the expansion board.
7. Remove the expansion board.
8. Remove the PCIe riser cage.

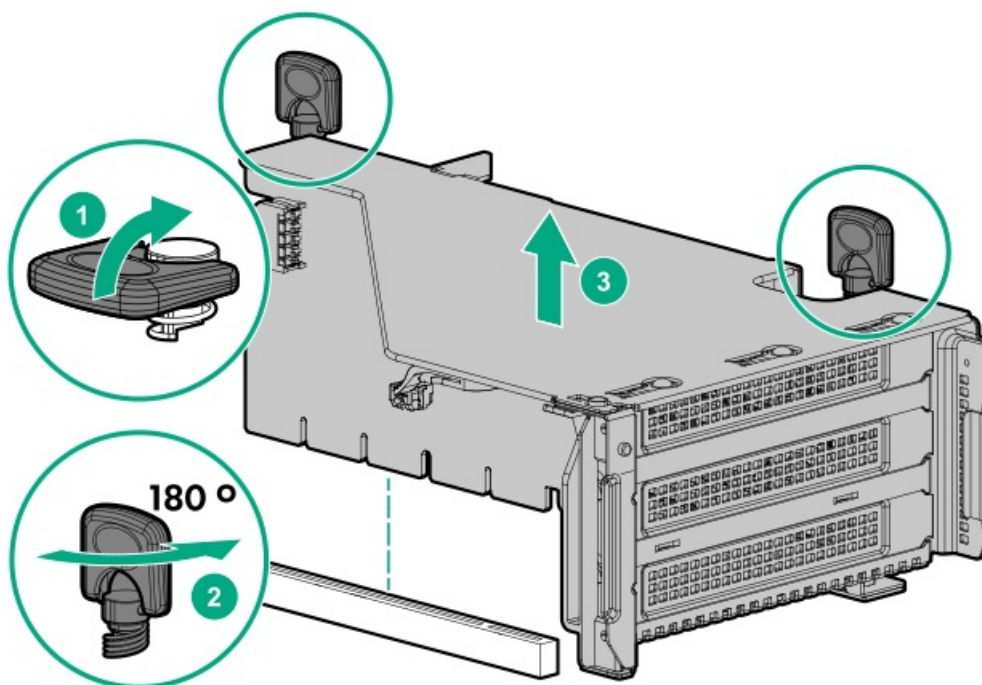

To replace the component, reverse the removal procedure.

Removing and replacing the secondary and tertiary PCIe riser cages

CAUTION: To prevent improper cooling or thermal damage, the server PCI slots must have an expansion slot blank or an expansion board installed.

Procedure

1. Power down the server.
2. Remove all power:
 - a. Disconnect each power cord from the power source.
 - b. Disconnect each power cord from the server.

3. Disconnect any external cables that are connected to the expansion board.
4. Do one of the following:
 - [Extend the server from the rack.](#)
 - [Remove the server from the rack.](#)
5. [Remove the access panel.](#)
6. Disconnect any internal cables that are connected to the expansion board.
7. [Removing and replacing an expansion board.](#)
8. Remove the PCIe riser cage.

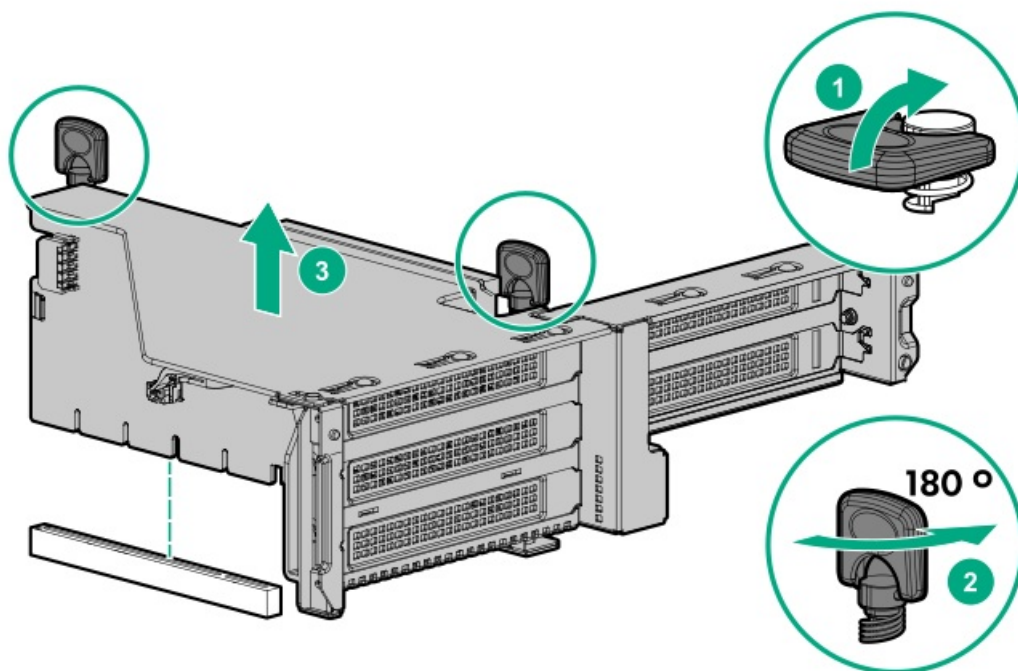

To replace the component, reverse the removal procedure.

Removing and replacing the PCIe riser blank

CAUTION: To prevent improper cooling or thermal damage, the server PCI slots must have an expansion slot blank or an expansion board installed.

Procedure

1. Power down the server ([Power down the server](#)).
2. Remove all power:
 - a. Disconnect each power cord from the power source.
 - b. Disconnect each power cord from the server.
3. Do one of the following:
 - Extend the server from the rack ([Extend the server from the rack](#)).
 - Remove the server from the rack ([Remove the server from the rack](#)).
4. Remove the access panel ([Remove the access panel](#)).

5. Remove the PCIe riser blank:

- Primary or secondary

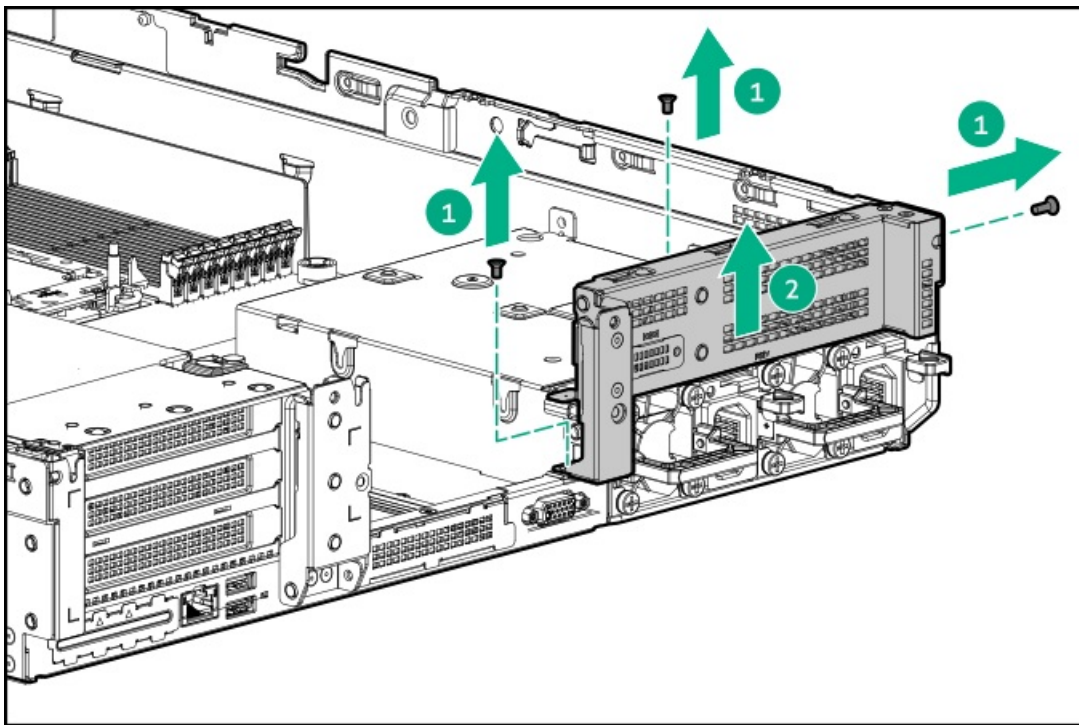
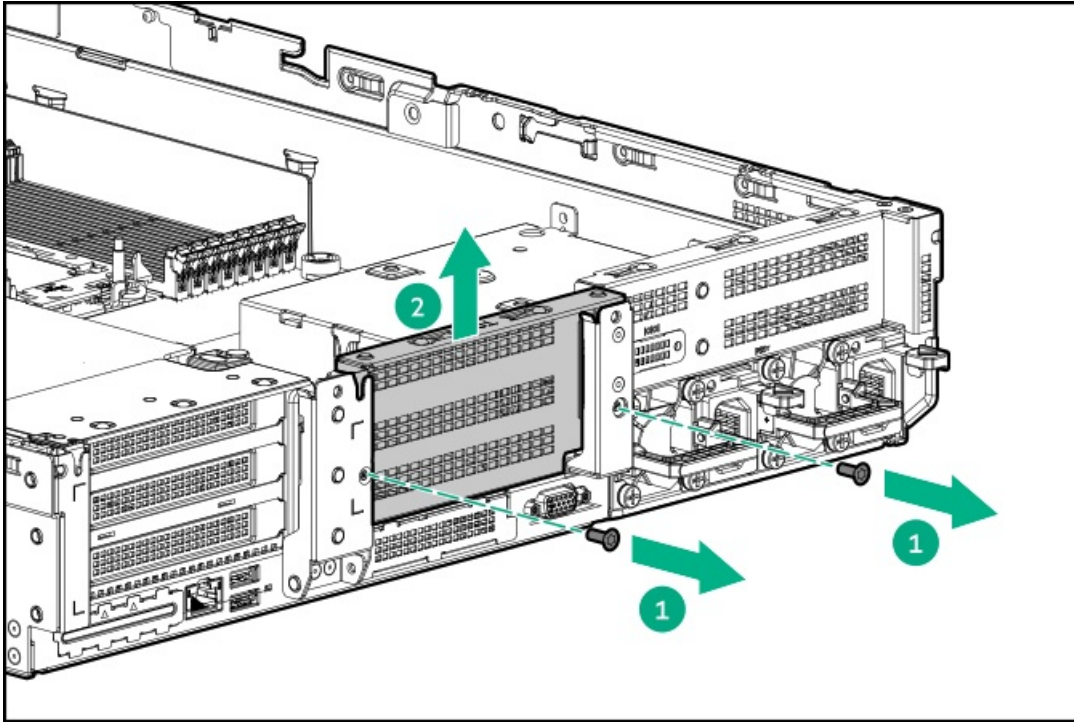

- Tertiary

To replace the component, reverse the removal procedure.

Removing and replacing the PCIe riser board

Prerequisites

Before you perform this procedure, make sure that you have a T-15 Torx screwdriver available.

Procedure

1. Power down the server.
2. Remove all power:
 - a. Disconnect each power cord from the power source.
 - b. Disconnect each power cord from the server.
3. Do one of the following:
 - Extend the server from the rack.
 - Remove the server from the rack.
4. Remove the access panel.
5. Release the full-length expansion board retainer if necessary .
6. Remove the PCIe riser cage:
 - Remove the primary PCIe riser cages
 - Remove the secondary and tertiary PCIe riser cage
7. Remove any expansion boards from the PCIe riser cage.
8. Remove the PCIe riser board:
 - Primary and secondary riser cage

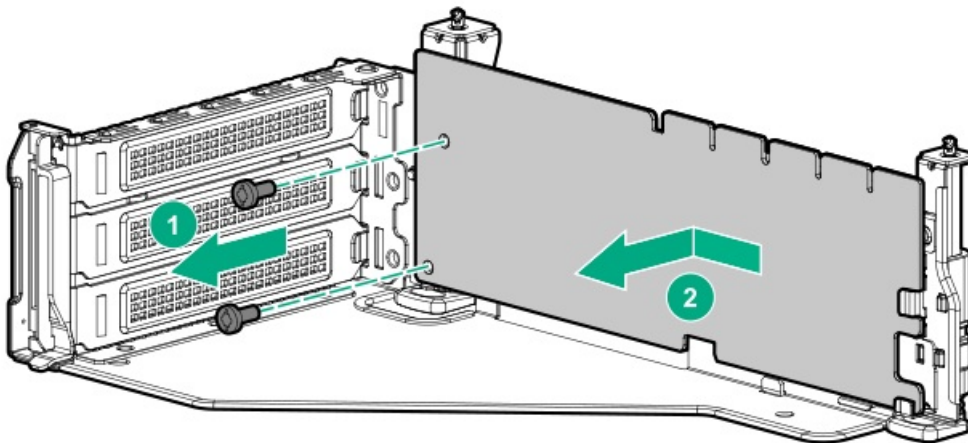

- Tertiary riser cage

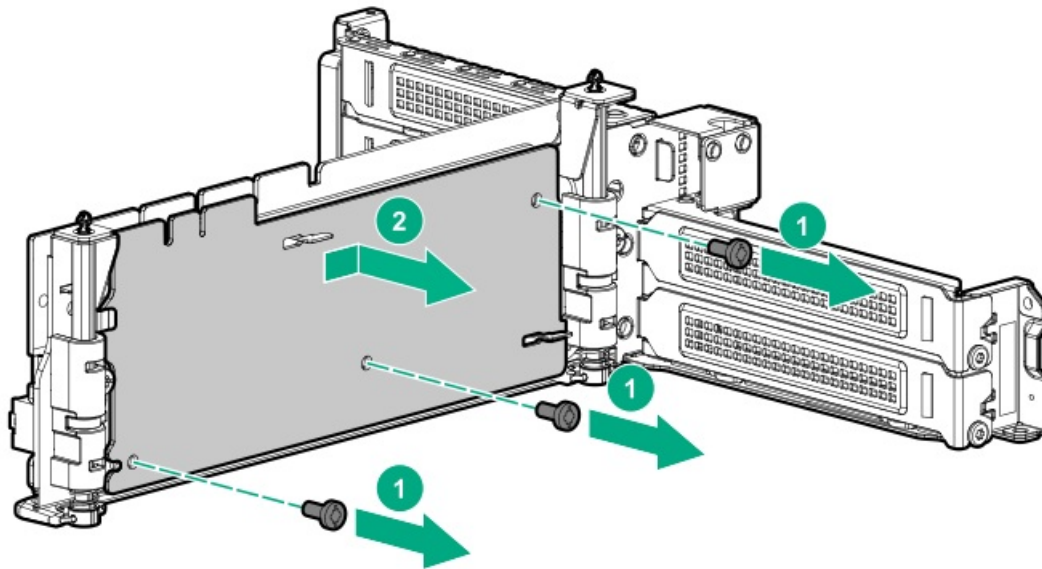

To replace the component, reverse the removal procedure.

Removing and replacing an expansion slot blank

⚠ WARNING: To reduce the risk of personal injury, electric shock, or damage to the equipment, remove power from the server by removing the power cord. The front panel Power On/Standby button does not shut off system power. Portions of the power supply and some internal circuitry remain active until AC power is removed.

⚠ CAUTION: For proper cooling, do not operate the server without the access panel, baffles, expansion slot covers, or blanks installed. If the server supports hot-plug components, minimize the amount of time the access panel is open.

Procedure

1. Power down the server.
2. Remove all power:
 - a. Disconnect each power cord from the power source.
 - b. Disconnect each power cord from the server.
3. Do one of the following:
 - Extend the server from the rack.
 - Remove the server from the rack.
4. Remove the access panel.
5. Remove the PCIe riser cage:
 - Remove the primary PCIe riser cages
 - Remove the secondary and tertiary PCIe riser cage
6. Remove the expansion slot blank.

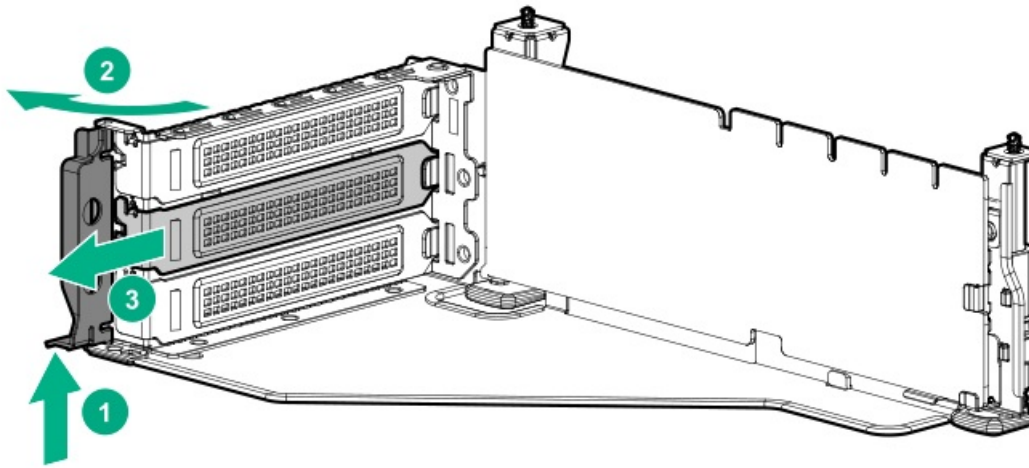

To replace the component, reverse the removal procedure.

Removing and replacing an expansion board

⚠ WARNING: To reduce the risk of personal injury, electric shock, or damage to the equipment, remove power from the server by removing the power cord. The front panel Power On/Standby button does not shut off system power. Portions of the power supply and some internal circuitry remain active until AC power is removed.

Procedure

1. Power down the server.
2. Remove all power:
 - a. Disconnect each power cord from the power source.
 - b. Disconnect each power cord from the server.
3. Disconnect any external cables that are connected to the expansion board.
4. Do one of the following:
 - Extend the server from the rack.
 - Remove the server from the rack.
5. Remove the access panel.
6. Disconnect any internal cables that are connected to the expansion board.
7. Release the full-length expansion board retainer if necessary.
8. Remove the PCIe riser cage:
 - Remove the primary PCIe riser cages.
 - Remove the secondary and tertiary PCIe riser cage.
9. Remove the expansion board.

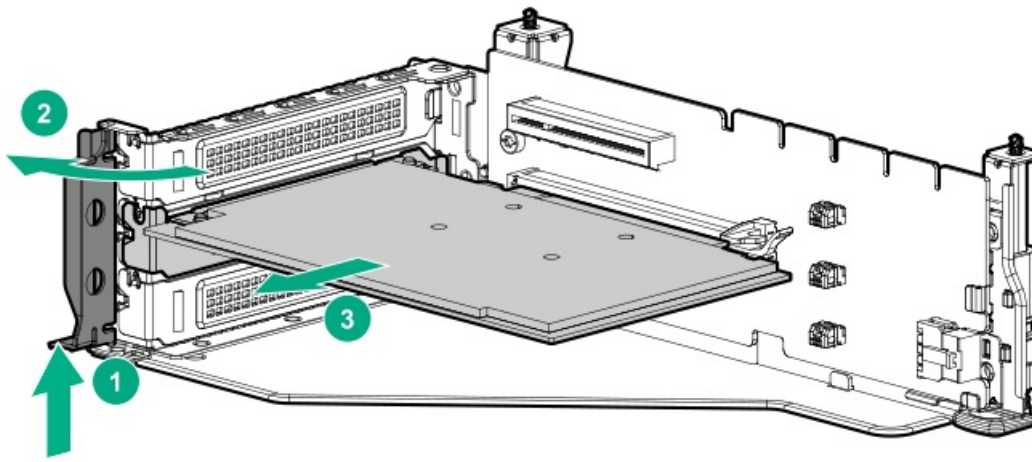

To replace the component, reverse the removal procedure.

Removing and replacing a GPU enablement board

⚠ WARNING: To reduce the risk of personal injury, electric shock, or damage to the equipment, remove the power cord to remove power from the server. The front panel Power On/Standby button does not shut off system power. Portions of the power supply and some internal circuitry remain active until AC power is removed.

⚠ CAUTION: To prevent improper cooling and thermal damage, do not operate the server unless all PCI slots have either an expansion slot cover or an expansion board installed.

Procedure

1. Power down the server.
2. Remove all power:
 - a. Disconnect each power cord from the power source.
 - b. Disconnect each power cord from the server.
3. Do one of the following:
 - Extend the server from the rack.
 - Remove the server from the rack.
4. Remove the access panel.
5. Remove the air baffle.
6. Release the full-length expansion board retainer.
7. Remove the PCIe riser cage:
 - Remove the primary PCIe riser cages
 - Remove the secondary and tertiary PCIe riser cage
8. Disconnect the power cable from the GPU.
9. Remove the GPU enablement board from the GPU-enabled riser cage:
 - Primary riser cage

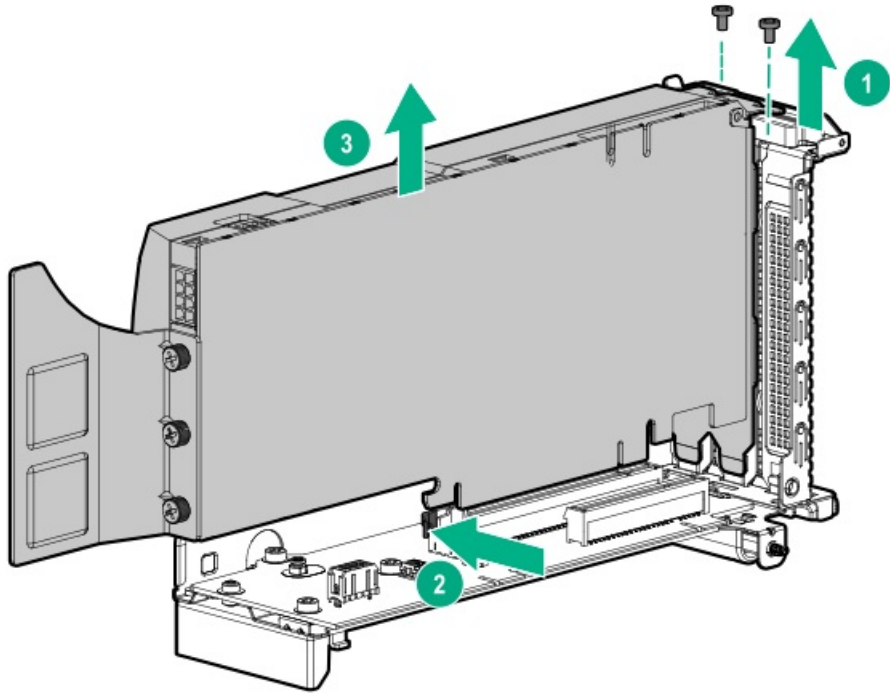

- Secondary and tertiary riser cage

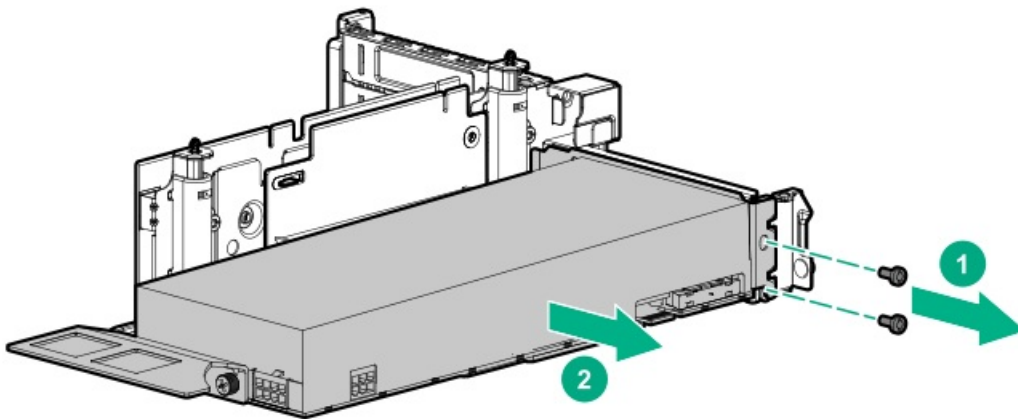

To replace the component, reverse the removal procedure.

Removing and replacing the fan cage

Procedure

1. Power down the server ([Power down the server](#)).
2. Remove all power:
 - a. Disconnect each power cord from the power source.
 - b. Disconnect each power cord from the server.
3. Do one of the following:
 - Extend the server from the rack ([Extend the server from the rack](#)).
 - Remove the server from the rack ([Remove the server from the rack](#)).
4. Remove the access panel ([Remove the access panel](#)).

5. Remove the fan cage.

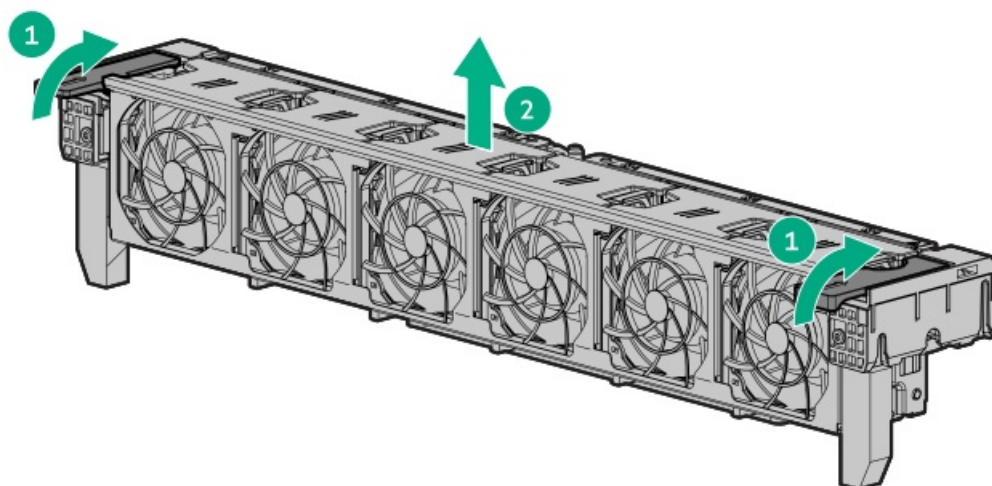

CAUTION: Do not operate the server for long periods with the access panel open or removed. Operating the server in this manner results in improper airflow and improper cooling that can lead to thermal damage.

IMPORTANT: For optimum cooling, install fans in all primary fan locations.

For more information, refer to the fan locations table in the server user guide.

To replace the component, reverse the removal procedure.

Removing and replacing the OCP NIC 3.0 adapter

WARNING: To reduce the risk of personal injury, electric shock, or damage to the equipment, remove power from the server by removing the power cord. The front panel Power On/Standby button does not shut off system power. Portions of the power supply and some internal circuitry remain active until AC power is removed.

Procedure

1. Power down the server.
2. Remove all power:
 - a. Disconnect each power cord from the power source.
 - b. Disconnect each power cord from the server.
3. Disconnect any external cables that are connected to the expansion board.
4. Do one of the following:
 - Extend the server from the rack.
 - Remove the server from the rack.
5. Remove the access panel.
6. Remove the secondary riser cage (if equipped) (Removing and replacing the secondary and tertiary PCIe riser cage.).
7. Remove the OCP 3.0 adapter.

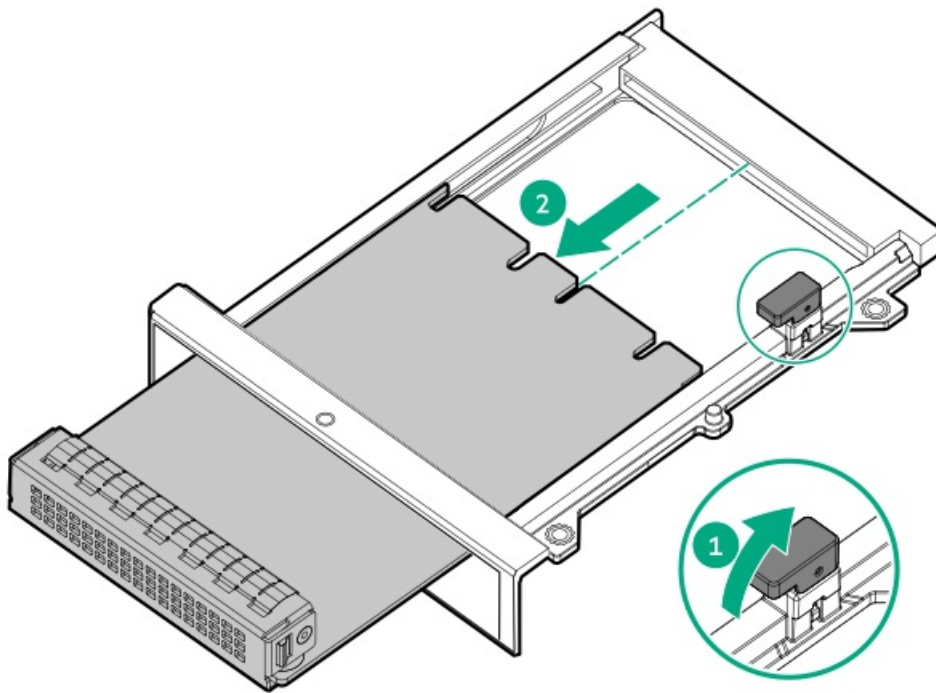

To replace the component, reverse the removal procedure.

Removing and replacing the SFF universal media bay

Prerequisites

Before you perform this procedure, make sure that you have a T-15 Torx screwdriver available.

Procedure

1. Power down the server.
2. Remove all power:
 - a. Disconnect each power cord from the power source.
 - b. Disconnect each power cord from the server.
3. Do one of the following:
 - Extend the server from the rack.
 - Remove the server from the rack.
4. Remove the access panel.
5. Remove all hot-plug hard drives.
6. Remove the fan cage.
7. Disconnect all cables from the universal media bay.
8. Remove the universal media bay.

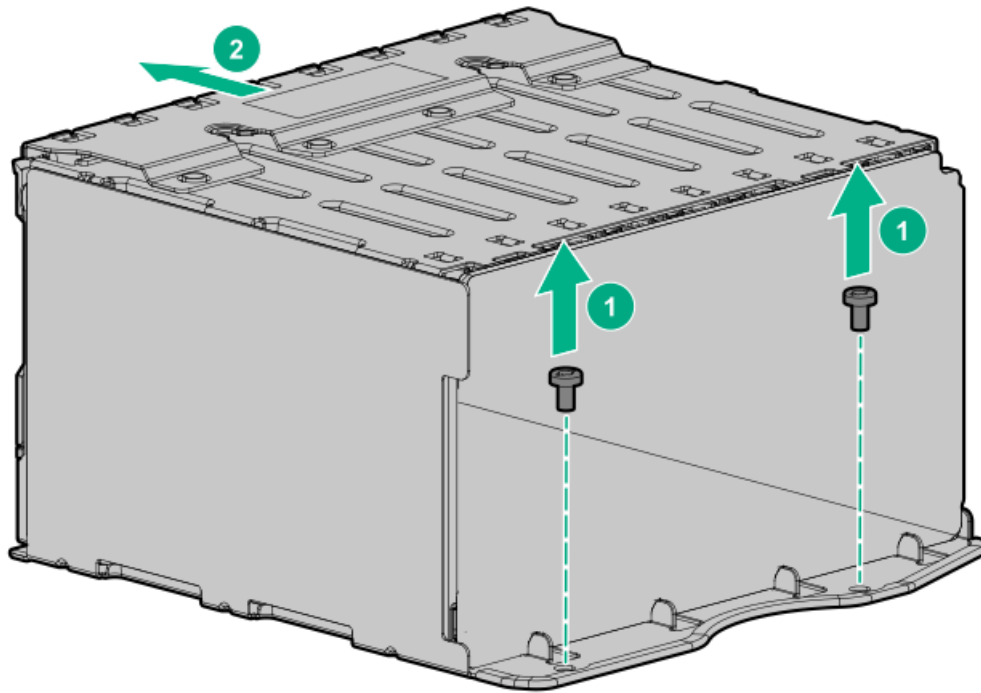

To replace the component, reverse the removal procedure.

Removing and replacing the LFF power switch module

Prerequisites

Before you perform this procedure, make sure that you have a T-10 Torx screwdriver available.

Procedure

1. Power down the server.
2. Remove all power:
 - a. Disconnect each power cord from the power source.
 - b. Disconnect each power cord from the server.
3. Do one of the following:
 - Extend the server from the rack.
 - Remove the server from the rack.
4. Remove the access panel.
5. Remove all hot-plug hard drives.
6. Remove the fan cage.
7. Disconnect all cables connecting the power switch module to the system board and other components.
8. Feeding the cables through the front of the server, remove the power switch module.

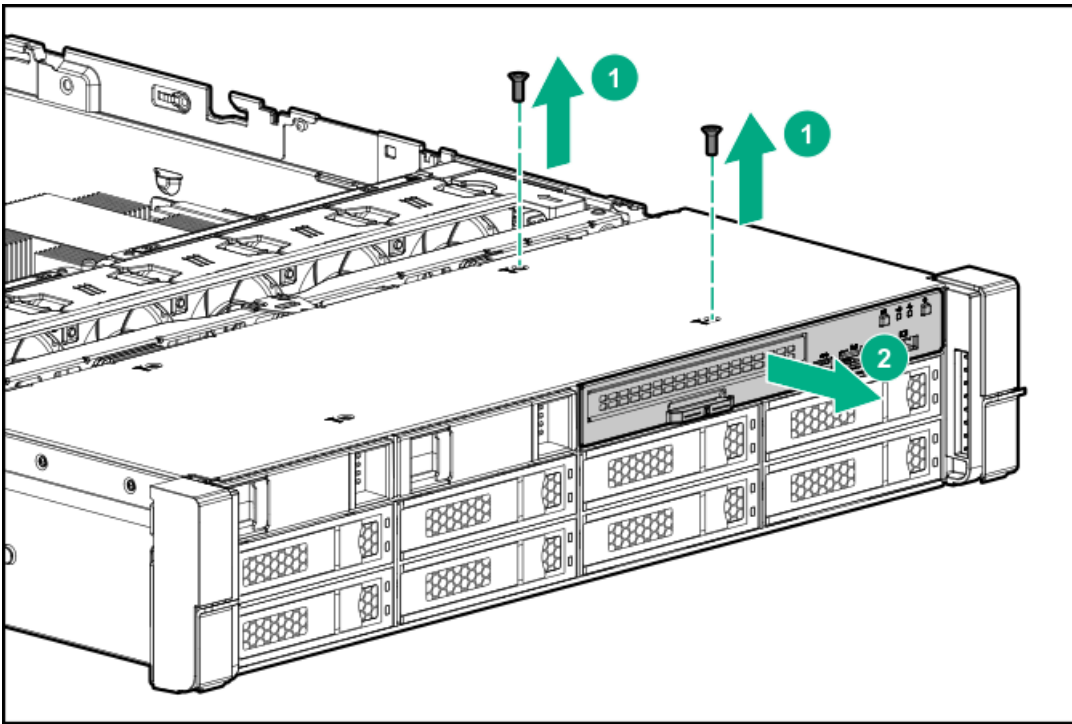

To replace the component, reverse the removal procedure.

Removing and replacing the SFF optical drive

Prerequisites

Before you perform this procedure, make sure that you have a T-10 Torx screwdriver available.

Procedure

1. Power down the server.
2. Remove all power:
 - a. Disconnect each power cord from the power source.
 - b. Disconnect each power cord from the server.
3. Do one of the following:
 - Extend the server from the rack.
 - Remove the server from the rack.
4. Remove the access panel.
5. Remove the fan cage.
6. Disconnect all cables from the SFF universal media bay.
7. Remove the SFF universal media bay.
8. Remove the optical drive.

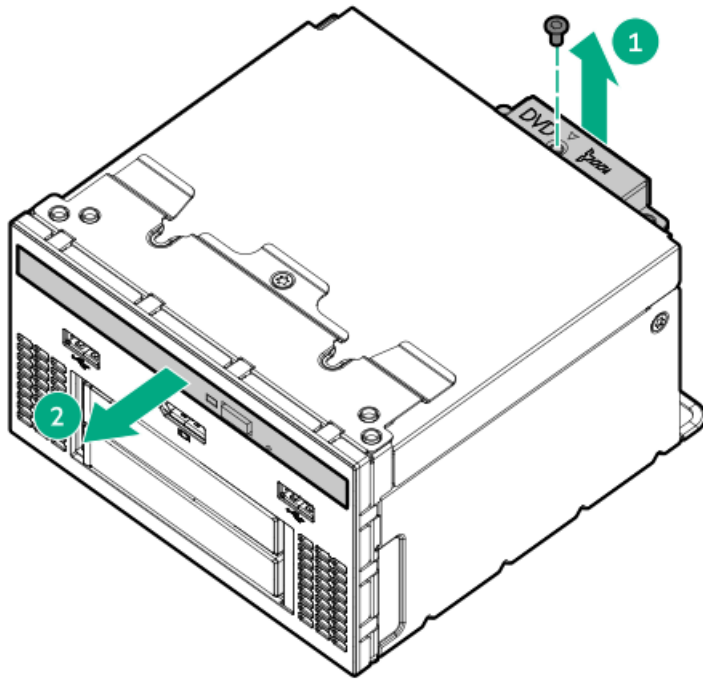

9. Remove the optical drive bracket and retain for use with the replacement optical drive.

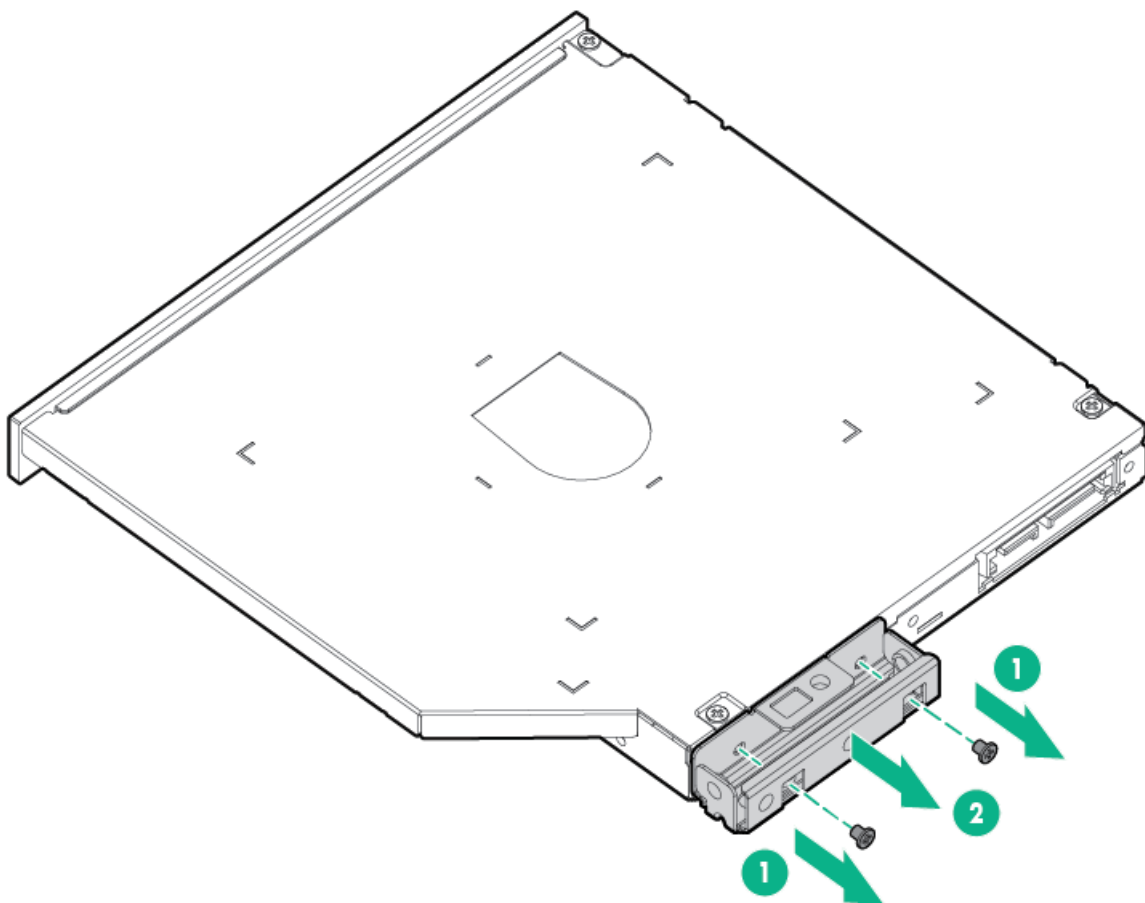

10. Before replacing the component, install the optical drive bracket retained from the optical drive you are replacing.



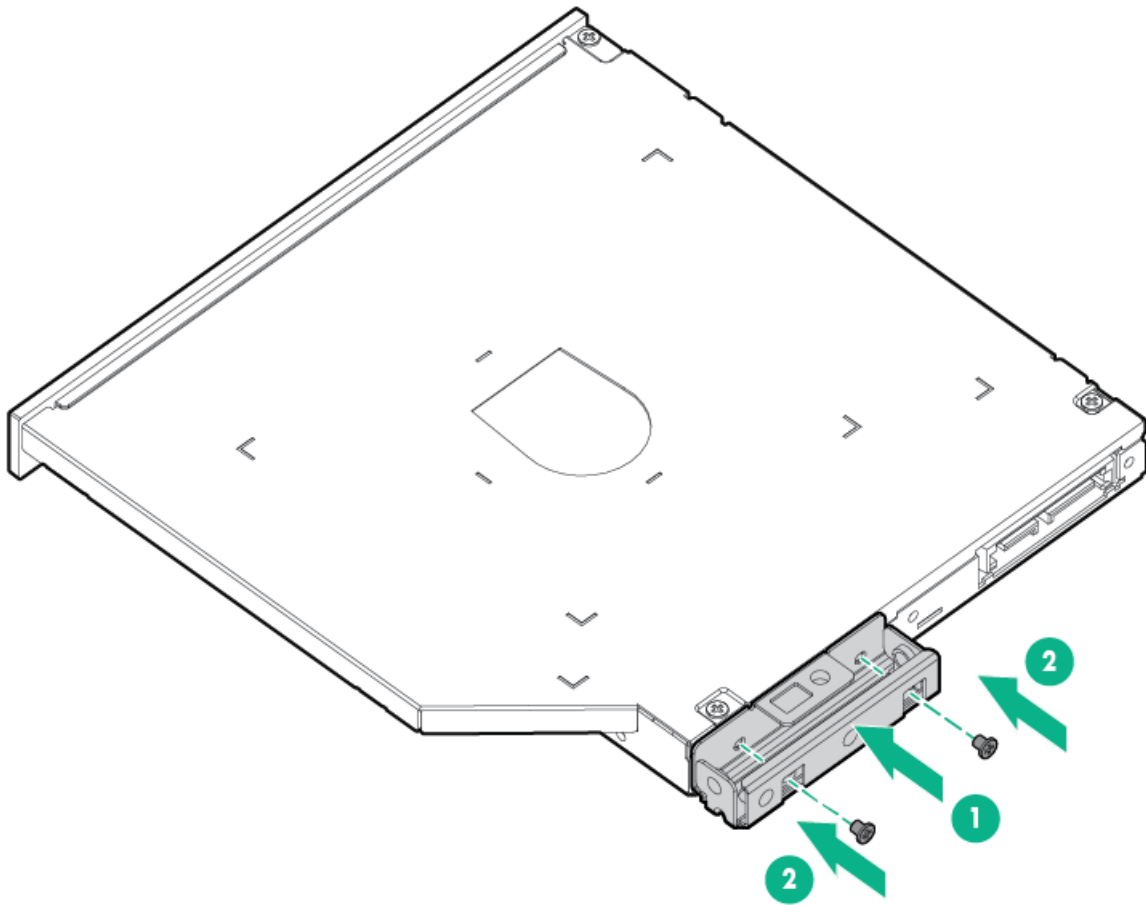

To replace the component, reverse the removal procedure.

Removing and replacing the LFF optical drive

Prerequisites

Before you perform this procedure, make sure that you have a T-10 Torx screwdriver available.

Procedure

1. Power down the server.
2. Remove all power:
 - a. Disconnect each power cord from the power source.
 - b. Disconnect each power cord from the server.
3. Do one of the following:
 - Extend the server from the rack.
 - Remove the server from the rack.
4. Remove the access panel.
5. Remove the fan cage.
6. Disconnect all cables from the LFF power switch module.
7. Remove the LFF power switch module.
8. Remove the optical drive.

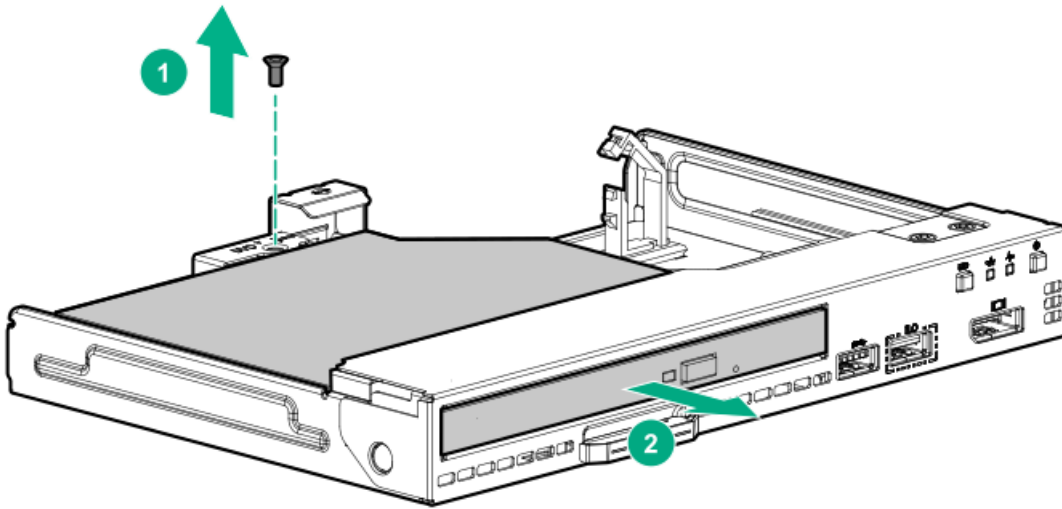

To replace the component, reverse the removal procedure.

Removing and replacing the 8 SFF drive cage

Prerequisites

Before you perform this procedure, make sure that you have a T-15 Torx screwdriver available.

Procedure

1. Power down the server.
2. Remove all power:
 - a. Disconnect each power cord from the power source.
 - b. Disconnect each power cord from the server.
3. Do one of the following:
 - Extend the server from the rack.
 - Remove the server from the rack.
4. Remove the access panel.
5. Remove all drives.
6. Remove the fan cage.
7. Disconnect all cables from the drive backplane.
8. Remove the drive cage.

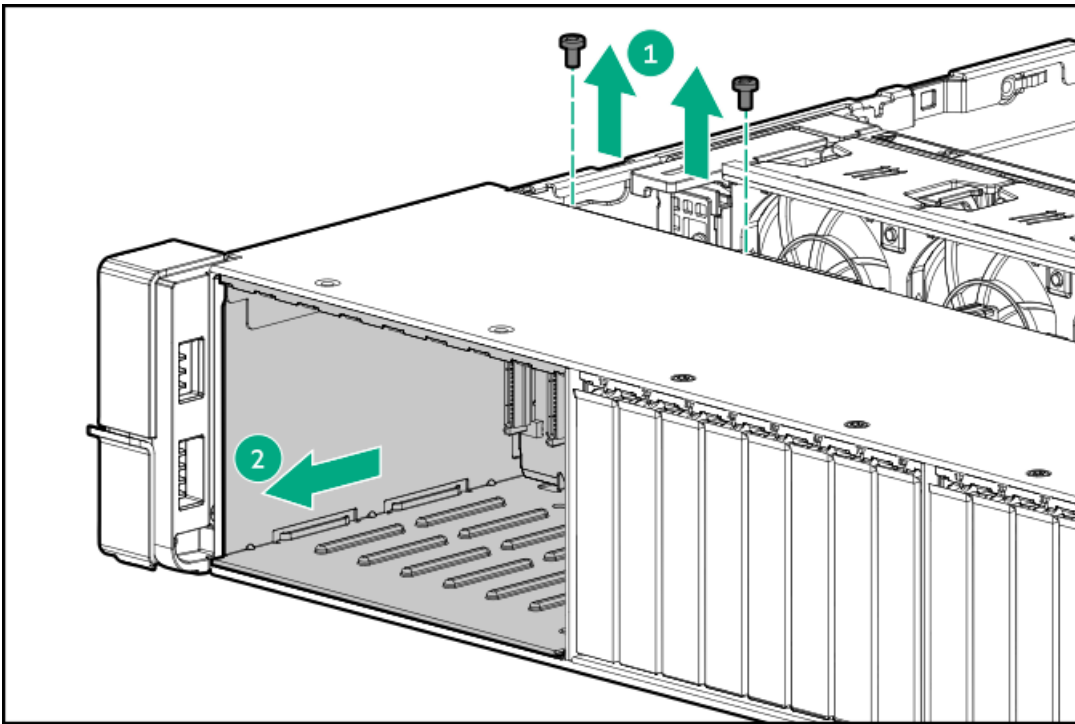

To replace the component, reverse the removal procedure.

Removing and replacing the 8 SFF drive backplane

Prerequisites

Before you perform this procedure, make sure that you have a T-15 Torx screwdriver available.

Procedure

1. Power down the server.
2. Remove all power:
 - a. Disconnect each power cord from the power source.
 - b. Disconnect each power cord from the server.
3. Do one of the following:
 - Extend the server from the rack.
 - Remove the server from the rack.
4. Remove the access panel.
5. Remove the fan cage.
6. Remove all drives.
7. Remove the 8 SFF drive cage.
8. Remove the drive backplane.

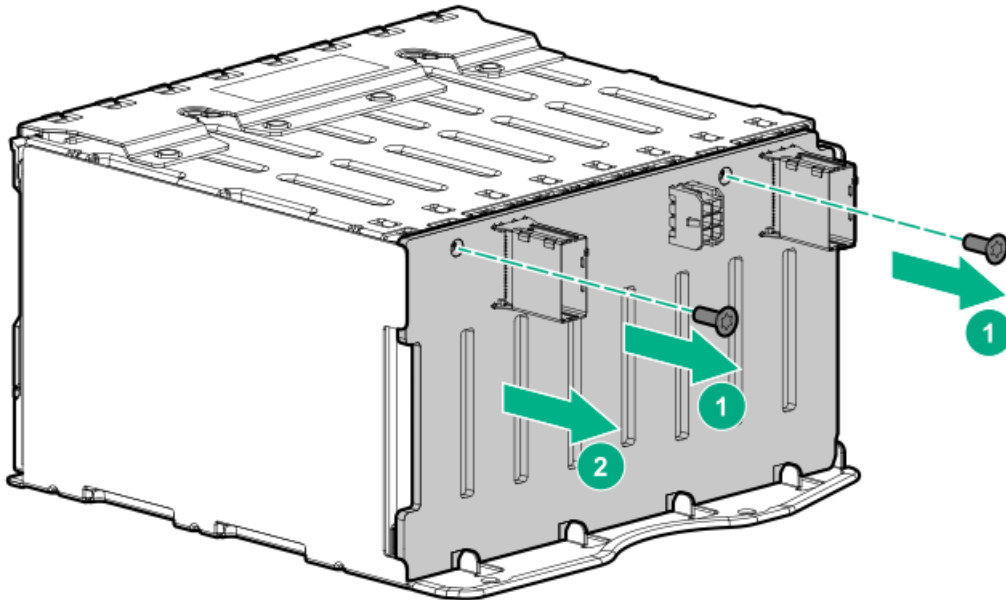

To replace the component, reverse the removal procedure.

Removing and replacing the 2 SFF front drive cage

Prerequisites

Before you perform this procedure, make sure that you have a T-10 Torx screwdriver available.

Procedure

1. Power down the server.
2. Remove all power:
 - a. Disconnect each power cord from the power source.
 - b. Disconnect each power cord from the server.
3. Do one of the following:
 - Extend the server from the rack.
 - Remove the server from the rack.
4. Remove the access panel.
5. Remove all drives.
6. Disconnect all cables from the drive backplane.
7. Remove the drive cage.

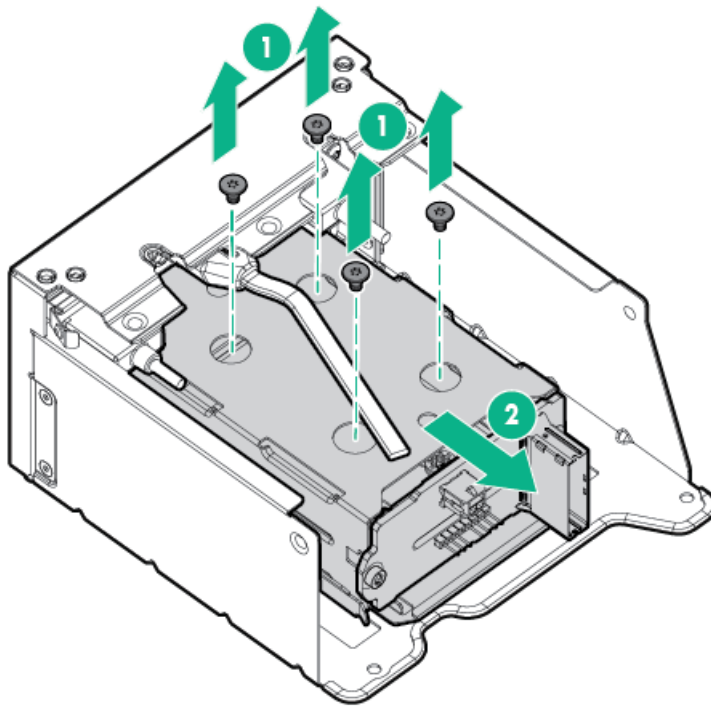

To replace the component, reverse the removal procedure.

Removing and replacing the 2 SFF rear drive bay and riser cage

Procedure

1. Power down the server.
2. Remove all power:
 - a. Disconnect each power cord from the power source.
 - b. Disconnect each power cord from the server.
3. Do one of the following:
 - Extend the server from the rack.
 - Remove the server from the rack.
4. Remove the access panel.
5. Remove all drives.
6. Disconnect all cables from the drive backplane.
7. Remove the drive cage.

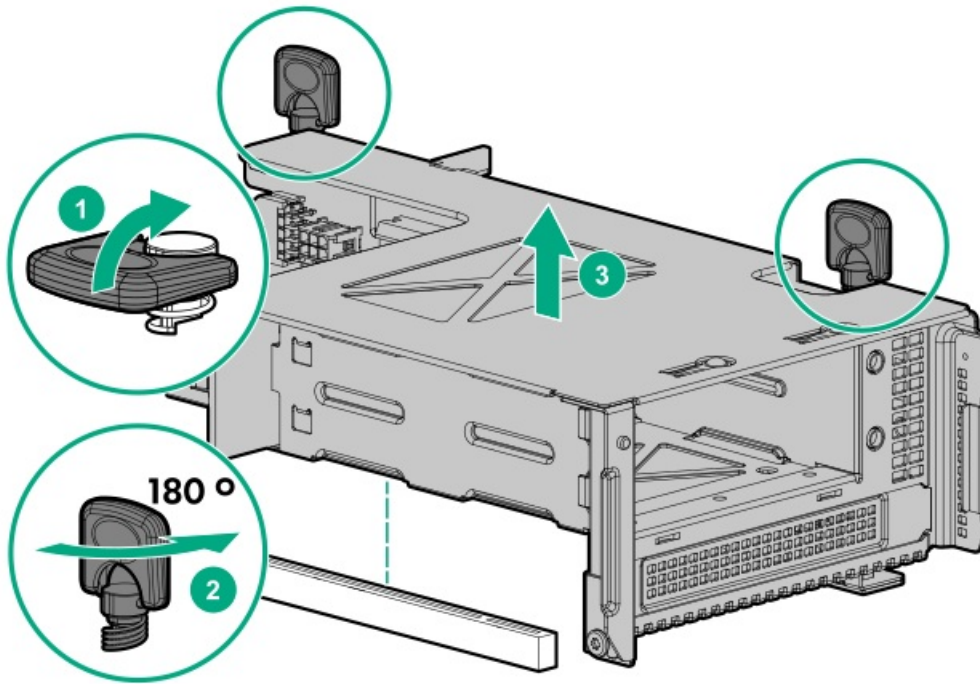

To replace the component, reverse the removal procedure.

Removing and replacing the 2 SFF drive cage

Procedure

1. Power down the server.
2. Remove all power:
 - a. Disconnect each power cord from the power source.
 - b. Disconnect each power cord from the server.
3. Do one of the following:
 - Extend the server from the rack.
 - Remove the server from the rack.
4. Remove the access panel.
5. Remove all drives.
6. Disconnect all cables from the drive backplane.
7. Remove the drive cage.

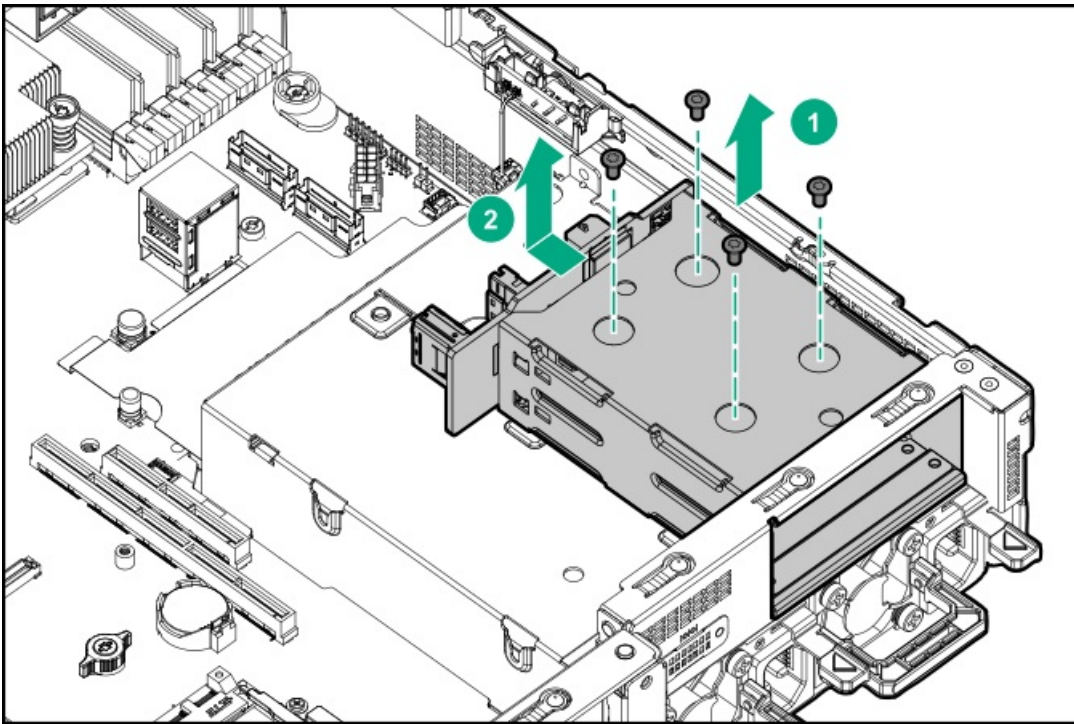

To replace the component, reverse the removal procedure.

Removing and replacing the 2 SFF rear drive backplane

Prerequisites

Before you perform this procedure, make sure that you have a T-15 Torx screwdriver available.

Procedure

1. Power down the server.
2. Remove all power:
 - a. Disconnect each power cord from the power source.
 - b. Disconnect each power cord from the server.
3. Do one of the following:
 - Extend the server from the rack.
 - Remove the server from the rack.
4. Remove the access panel.
5. Remove the fan cage.
6. Remove all drives.
7. Remove the 2 SFF drive cage.
8. Remove the drive backplane.

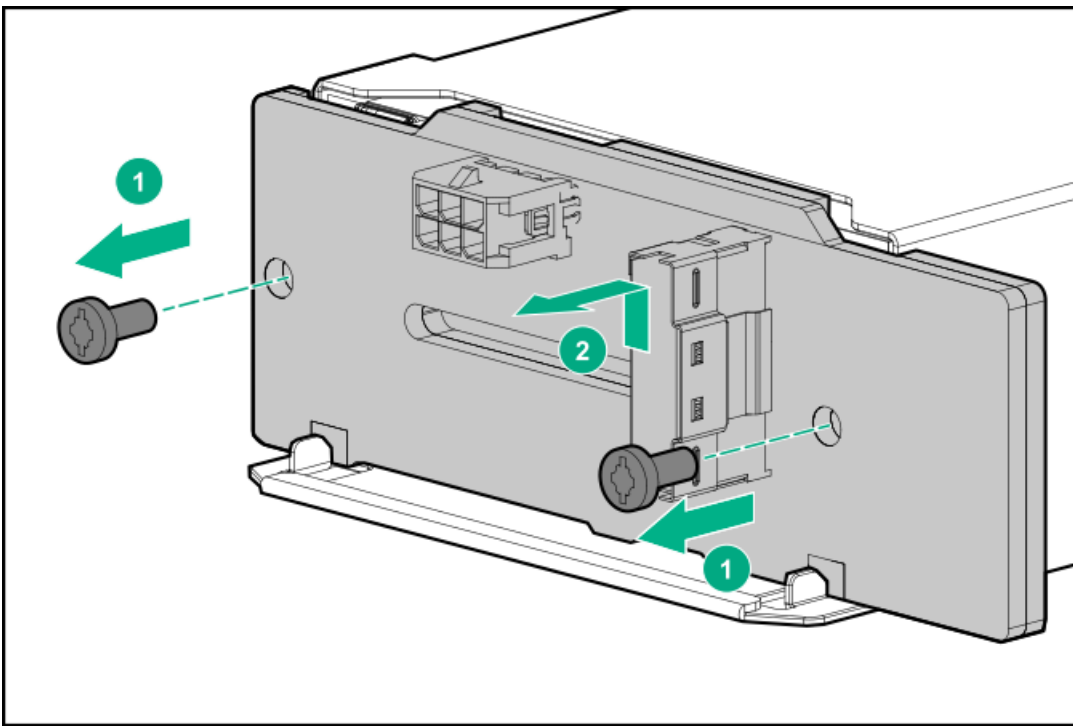

To replace the component, reverse the removal procedure.

Removing and replacing a midplane drive cage

Procedure

1. Power down the server ([Power down the server](#)).
2. Remove all power:
 - a. Disconnect each power cord from the power source.
 - b. Disconnect each power cord from the server.
3. Do one of the following:
 - Extend the server from the rack ([Extend the server from the rack](#)).
 - Remove the server from the rack ([Remove the server from the rack](#)).
4. Remove the access panel ([Remove the access panel](#)).
5. If installed, remove all riser cages:
 - Primary or secondary PCIe riser cage ([Removing and replacing the primary PCIe riser cage](#))
 - Tertiary PCIe riser cage ([Removing and replacing the secondary and tertiary PCIe riser cages](#))
6. Disconnect the power and cables from the drive cage.
7. Lift the blue tabs on the drive cage.
8. Remove all drives ([Removing and replacing a hot-plug SAS, SATA or NVMe drive](#)).
9. Pull the plunger pin to unlock the drive cage.
10. Using both hands, remove the drive cage from the server.

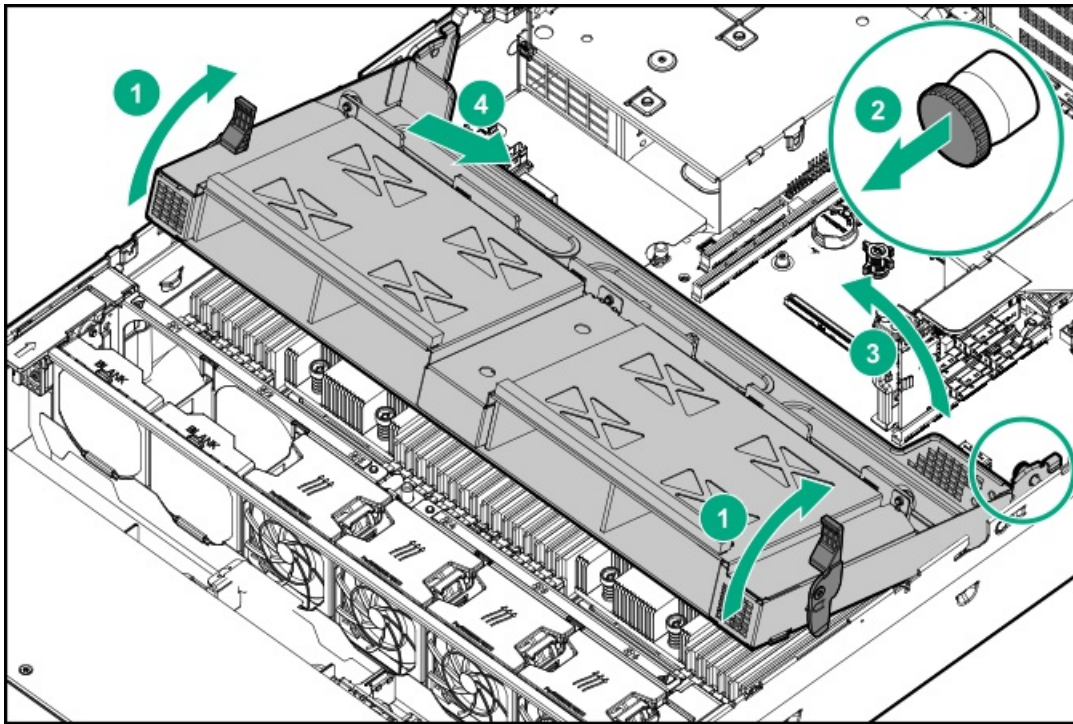

To replace the component, reverse the removal procedure.

Removing and replacing the midplane drive backplane

Prerequisites

Before you perform this procedure, make sure that you have a T-15 Torx screwdriver available.

Procedure

1. Power down the server.
2. Remove all power:
 - a. Disconnect each power cord from the power source.
 - b. Disconnect each power cord from the server.
3. Do one of the following:
 - Extend the server from the rack.
 - Remove the server from the rack.
4. Remove the access panel.
5. Remove the midplane cage.
6. Remove the NVMe drive backplane.

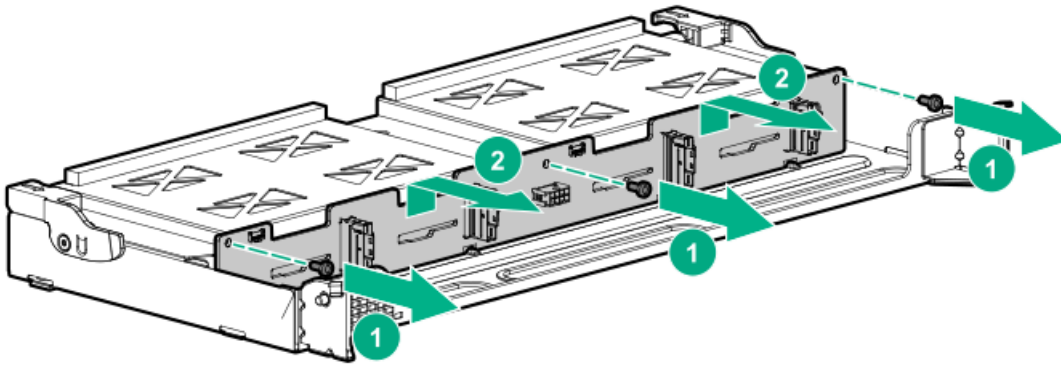

To replace the component, reverse the removal procedure.

Removing and replacing the 2LFF rear drive bay and riser cage

Procedure

1. Power down the server ([Power down the server](#)).
2. Remove all power:
 - a. Disconnect each power cord from the power source.
 - b. Disconnect each power cord from the server.
3. Do one of the following:
 - Extend the server from the rack ([Extend the server from the rack](#)).
 - Remove the server from the rack ([Remove the server from the rack](#)).
4. Remove the access panel ([Remove the access panel](#)).
5. Remove all drives ([Removing and replacing a hot-plug SAS, SATA or NVMe drive](#)).
6. Disconnect all cables from the drive backplane.
7. Remove the drive cage.

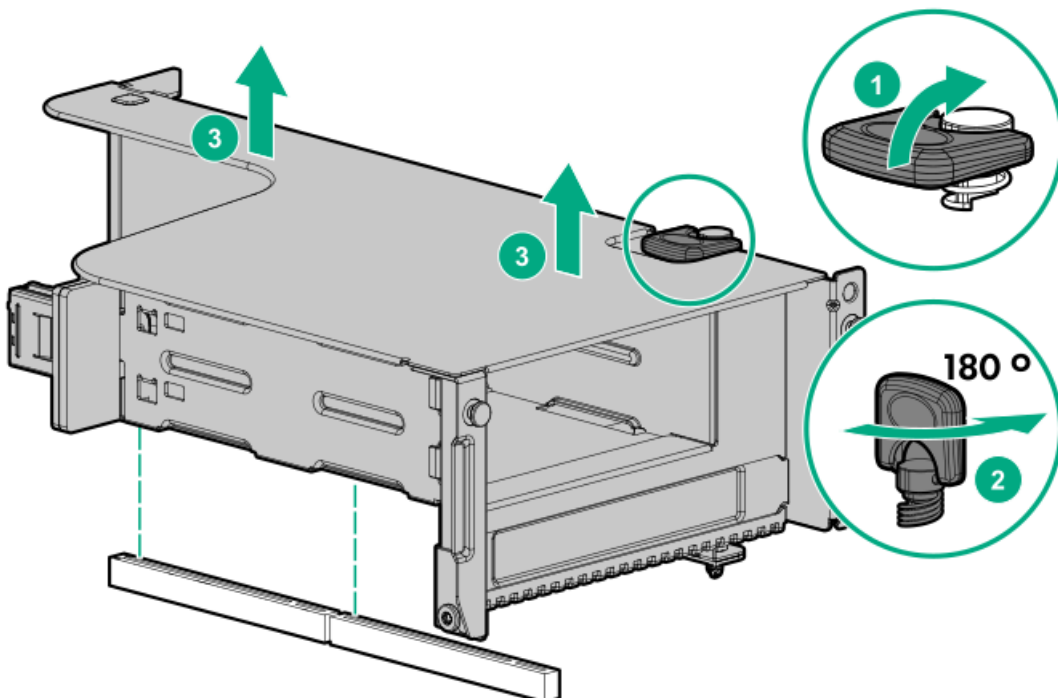

To replace the component, reverse the removal procedure.

Removing and replacing the LFF backplane assembly

Prerequisites

Before you perform this procedure, make sure that you have a T-10 Torx screwdriver available.

Procedure

1. Power down the server.
2. Remove all power:
 - a. Disconnect each power cord from the power source.
 - b. Disconnect each power cord from the server.
3. Do one of the following:
 - Extend the server from the rack.
 - Remove the server from the rack.
4. Remove the access panel.
5. Remove the fan cage).
6. Remove all drives.
7. Disconnect all cables connected to the LFF backplane assembly.
8. Remove the LFF backplane assembly.

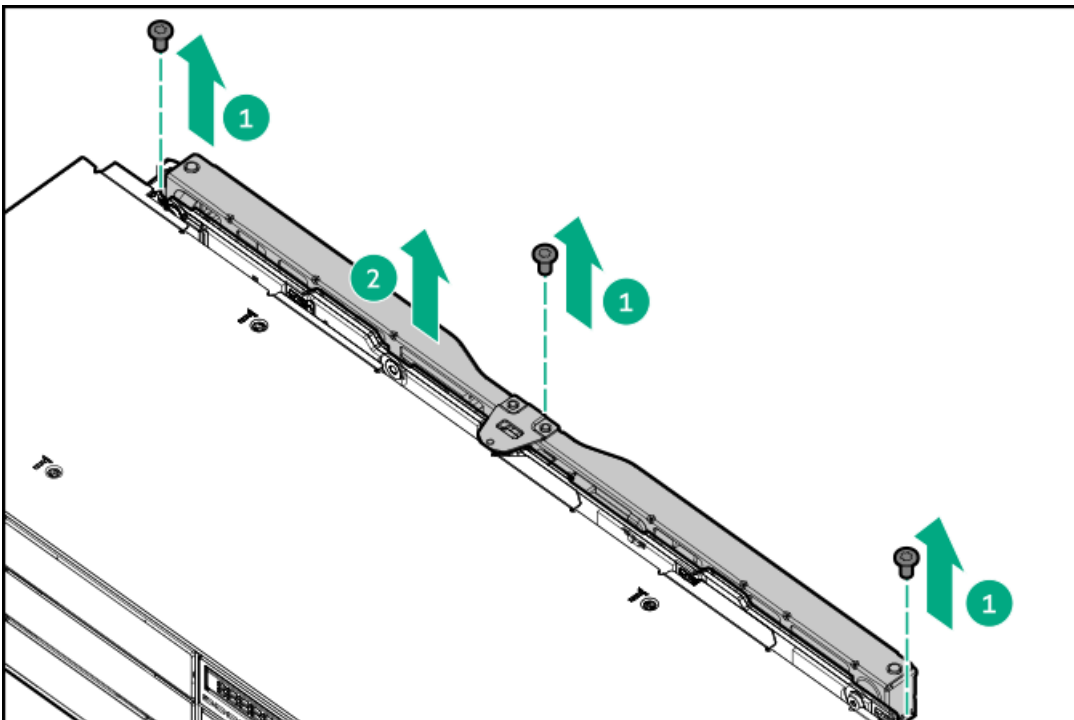

To replace the component, reverse the removal procedure.

Removing and replacing a front LFF drive backplane

Prerequisites

Before you perform this procedure, make sure that you have a T-15 Torx screwdriver available.

Procedure

1. Power down the server.
2. Remove all power:
 - a. Disconnect each power cord from the power source.
 - b. Disconnect each power cord from the server.
3. Do one of the following:
 - Extend the server from the rack.
 - Remove the server from the rack.
4. Remove the access panel.
5. Remove the fan cage.
6. Remove all drives.
7. Disconnect all cables connected to the LFF backplane assembly.
8. Remove the LFF backplane assembly.

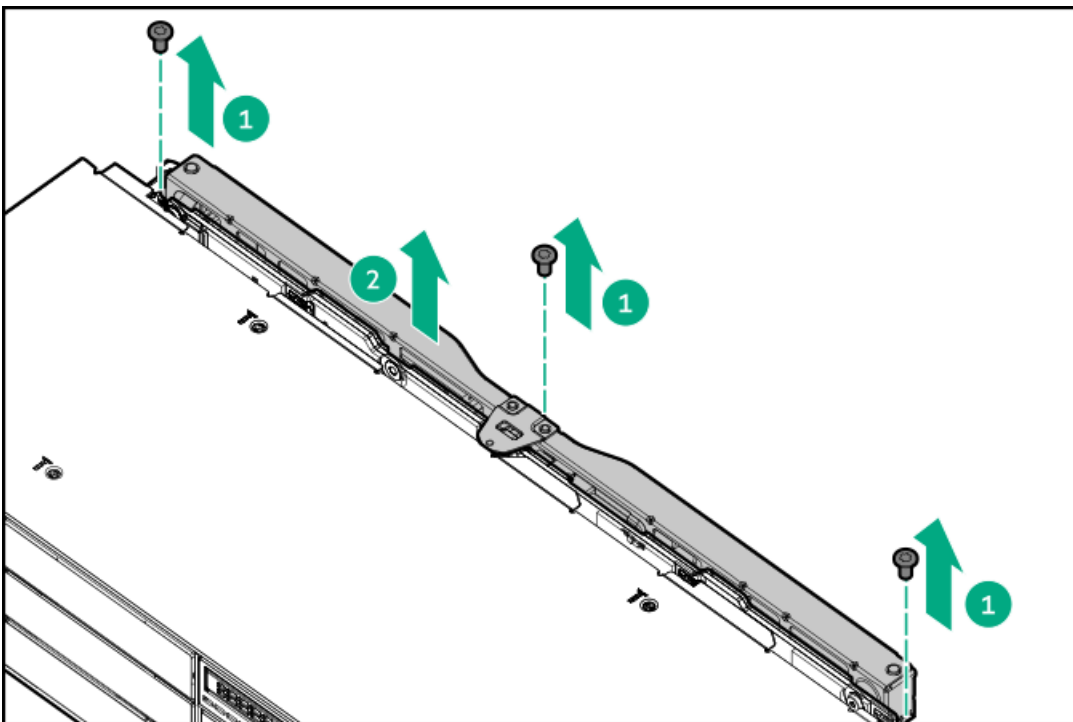

9. Remove the drive backplane.

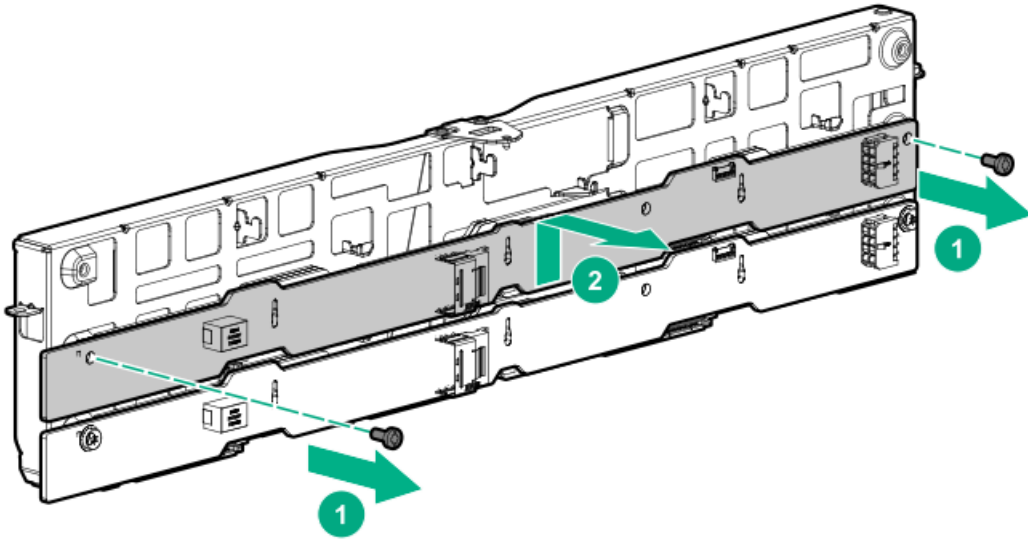

To replace the component, reverse the removal procedure.

Removing and replacing a rear serial port interface (primary)

Prerequisites

Before you perform this procedure, make sure that you have a T-10 Torx screwdriver available.

Procedure

1. Power down the server.
2. Remove all power:
 - a. Disconnect each power cord from the power source.
 - b. Disconnect each power cord from the server.
3. Do one of the following:
 - Extend the server from the rack.
 - Remove the server from the rack.
4. Remove the access panel.
5. Using a T-10 Torx screwdriver, remove the screws securing the serial port.

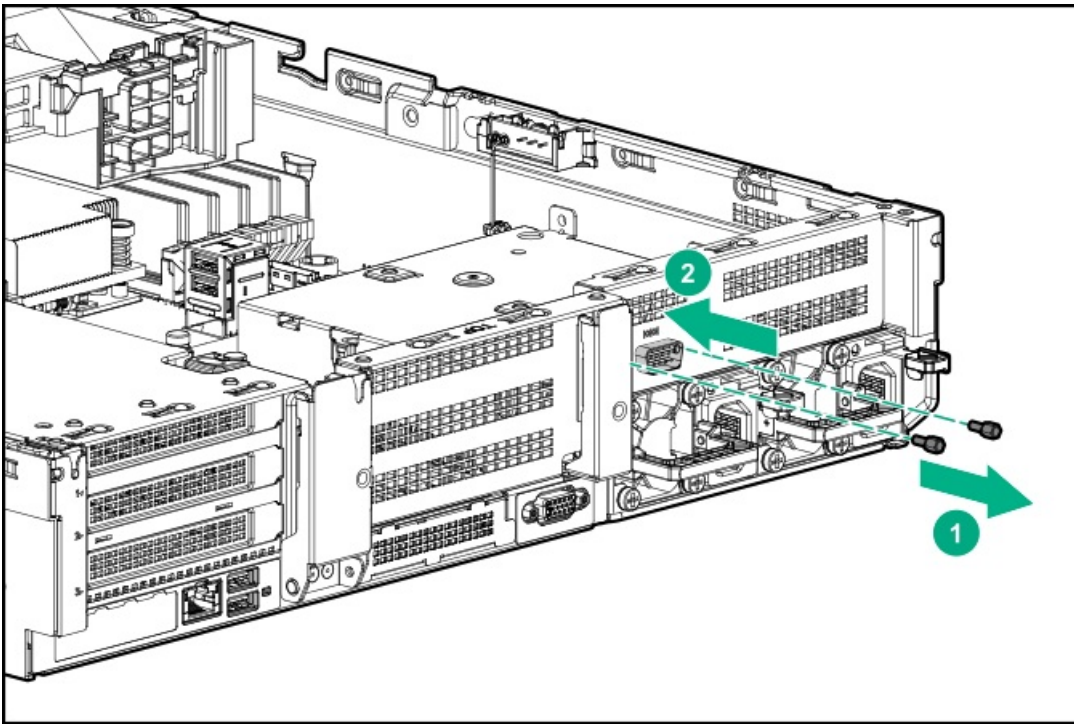

6. Disconnect and remove the serial cable.

To replace the component, reverse the removal procedure.

Removing and replacing an SFF power switch module

Prerequisites

Before you perform this procedure, make sure that you have a T-10 Torx screwdriver available.

Procedure

1. Power down the server.
2. Do one of the following:
 - Extend the server from the rack.
 - Remove the server from the rack.
3. Remove the access panel.
4. Disconnect cables from the power switch module.
5. Remove the power switch module.

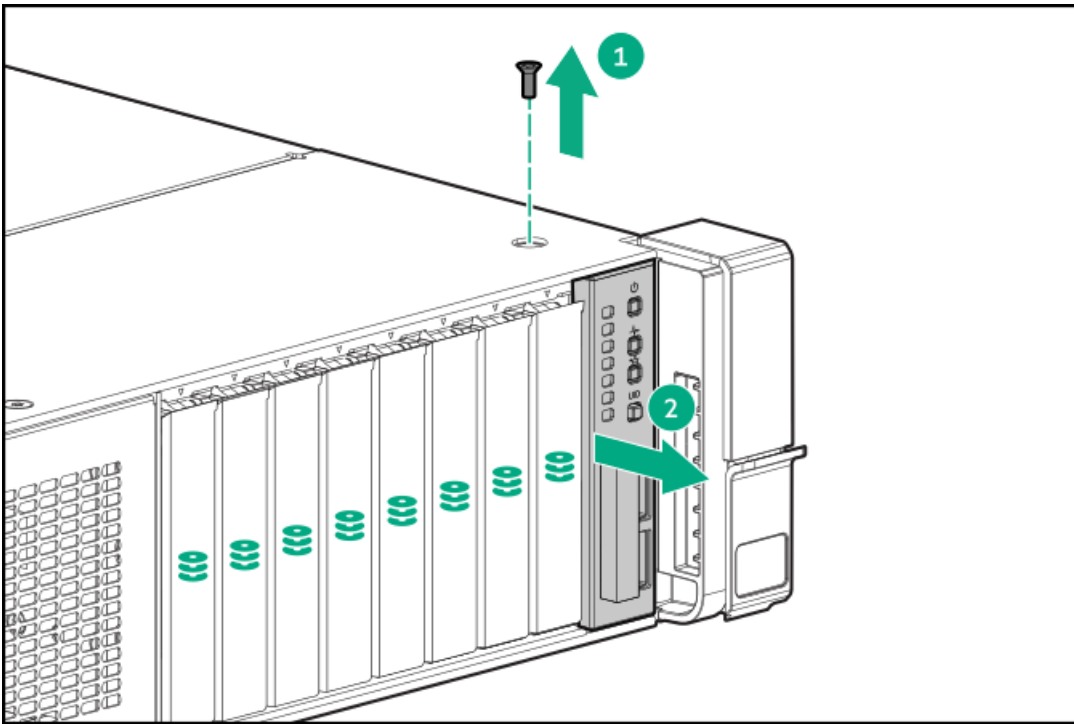

To replace the component, reverse the removal procedure.

Removing and replacing an SFF standard chassis ear

Procedure

1. Power down the server ([Power down the server](#)).
2. Remove all power:
 - a. Disconnect each power cord from the power source.
 - b. Disconnect each power cord from the server.
3. Do one of the following:
 - Extend the server from the rack ([Extend the server from the rack](#)).
 - Remove the server from the rack ([Remove the server from the rack](#)).
4. Remove the chassis ear.

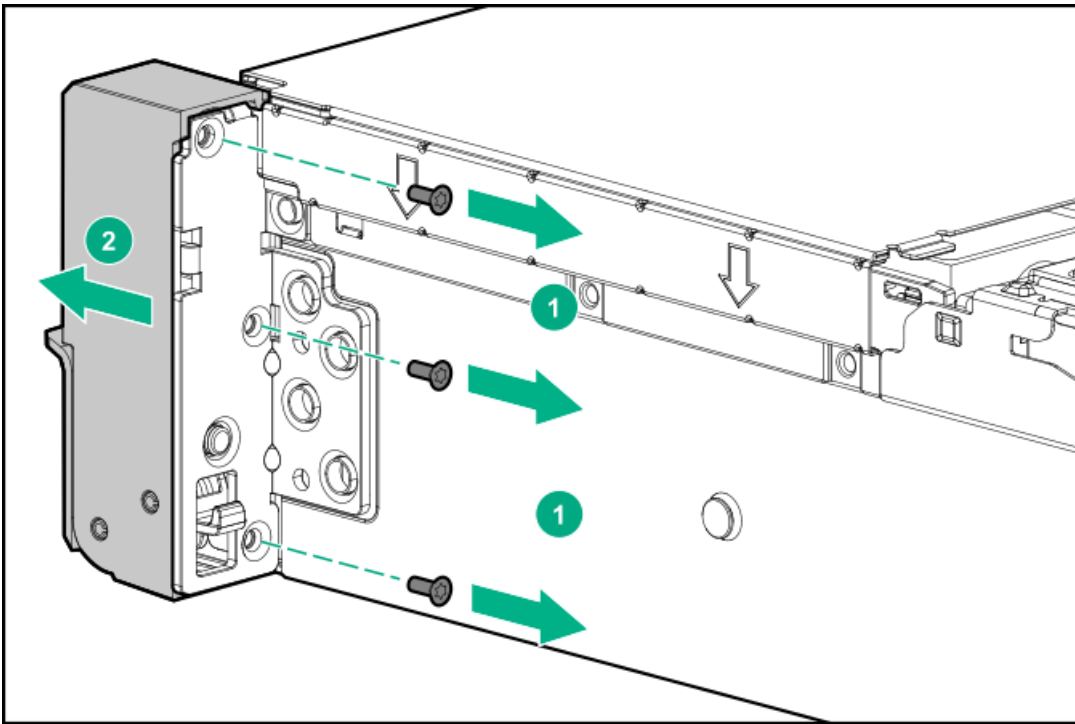

To replace the component, reverse the removal procedure.

Removing and replacing the LFF chassis ear assembly

Prerequisites

Before you perform this procedure, make sure that you have a T-10 Torx screwdriver available.

Procedure

1. Power down the server.
2. Remove all power:
 - a. Disconnect each power cord from the power source.
 - b. Disconnect each power cord from the server.
3. Remove the server from the rack.
4. Remove the access panel.
5. Disconnect the power switch cable.

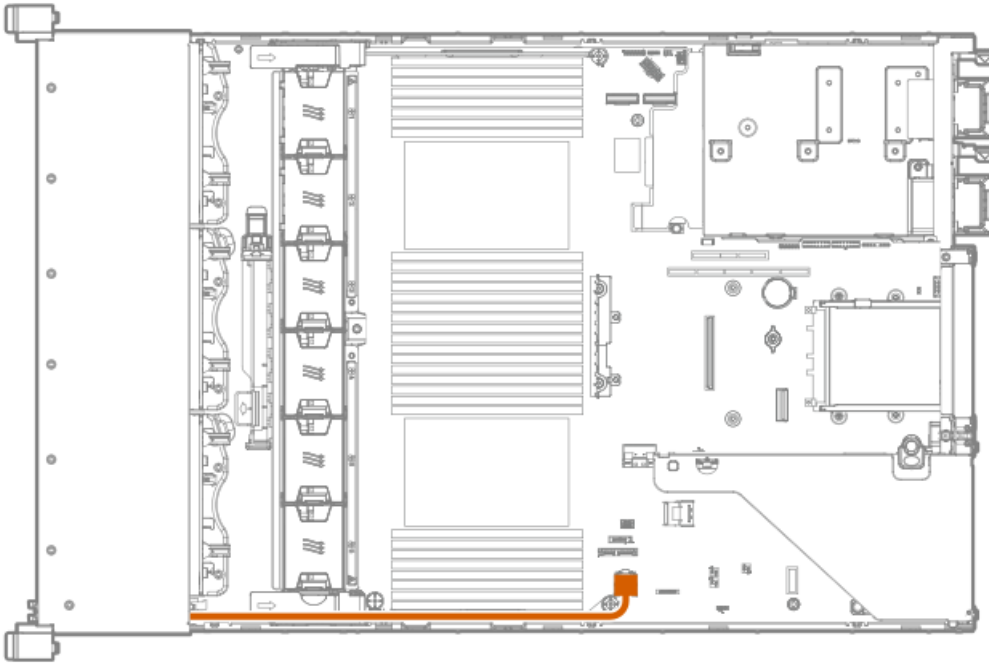

6. Remove the cable protection panel behind the chassis ear.

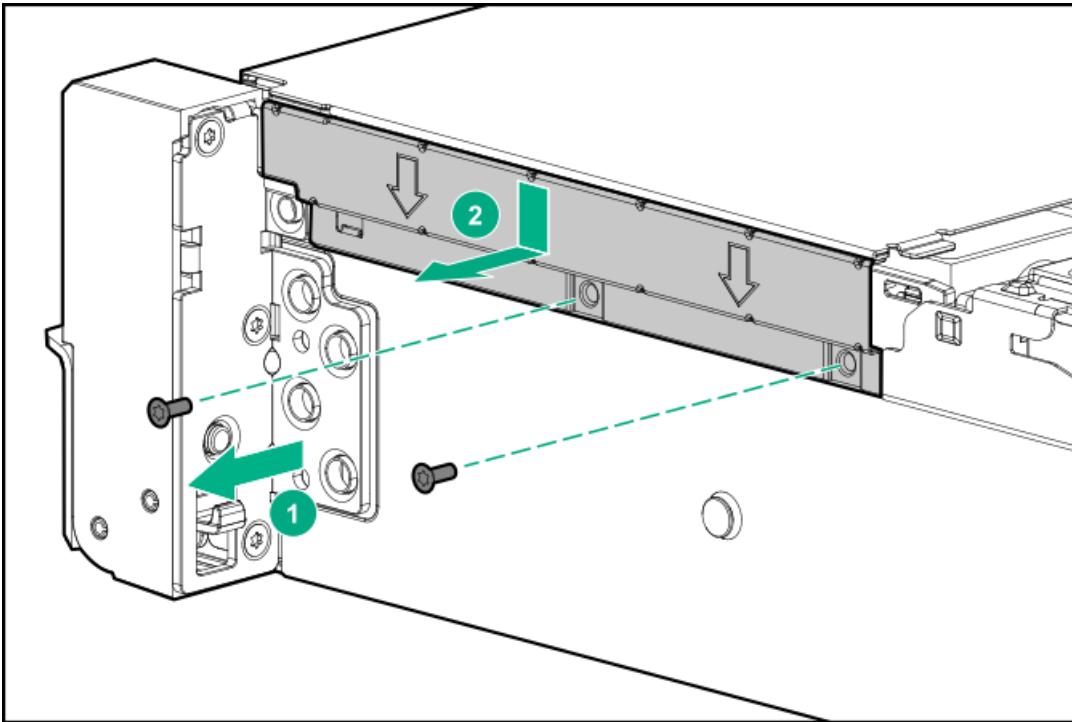

7. Remove the chassis ear assembly.



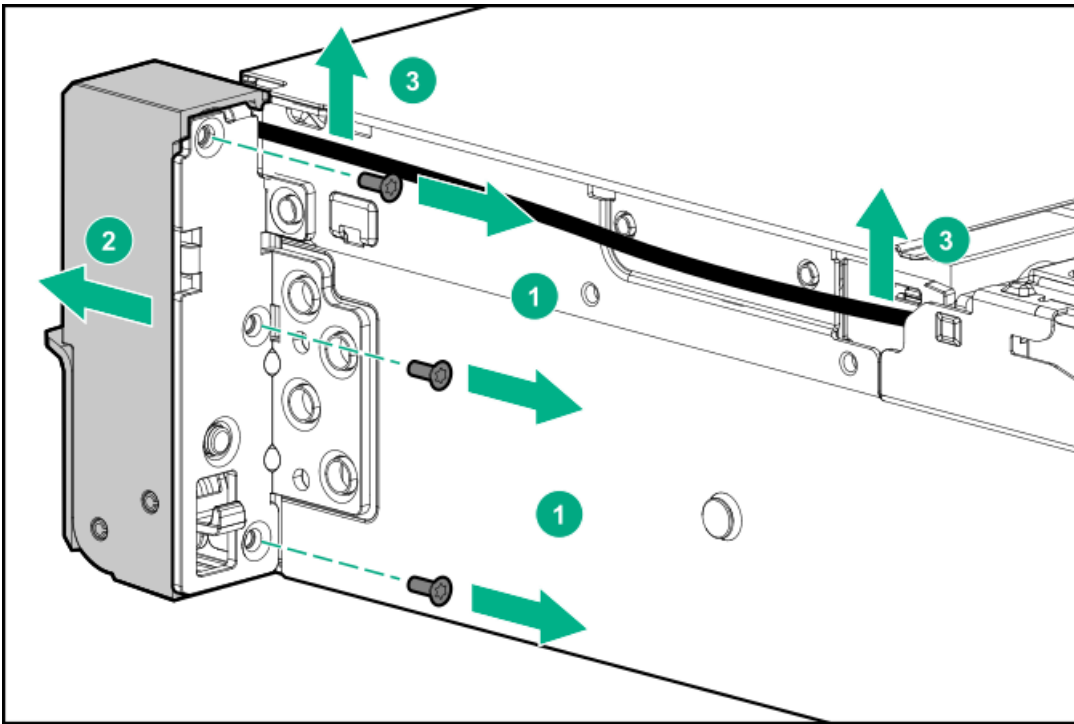

To replace the component, reverse the removal procedure.

Removing and replacing an LFF chassis ear with power/UID

Procedure

1. Power down the server ([Power down the server](#)).
2. Remove all power:
 - a. Disconnect each power cord from the power source.
 - b. Disconnect each power cord from the server.
3. Do one of the following:
 - Extend the server from the rack ([Extend the server from the rack](#)).
 - Remove the server from the rack ([Remove the server from the rack](#)).
4. Remove the access panel ([Remove the access panel](#)).
5. Disconnect the cable.

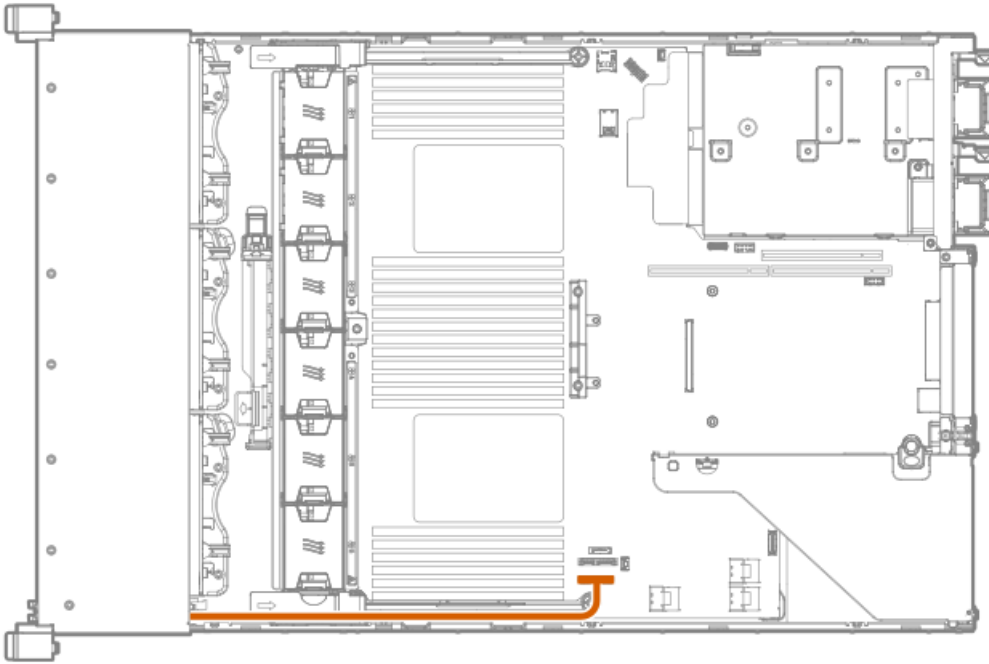

6. Remove the cable protection panel.

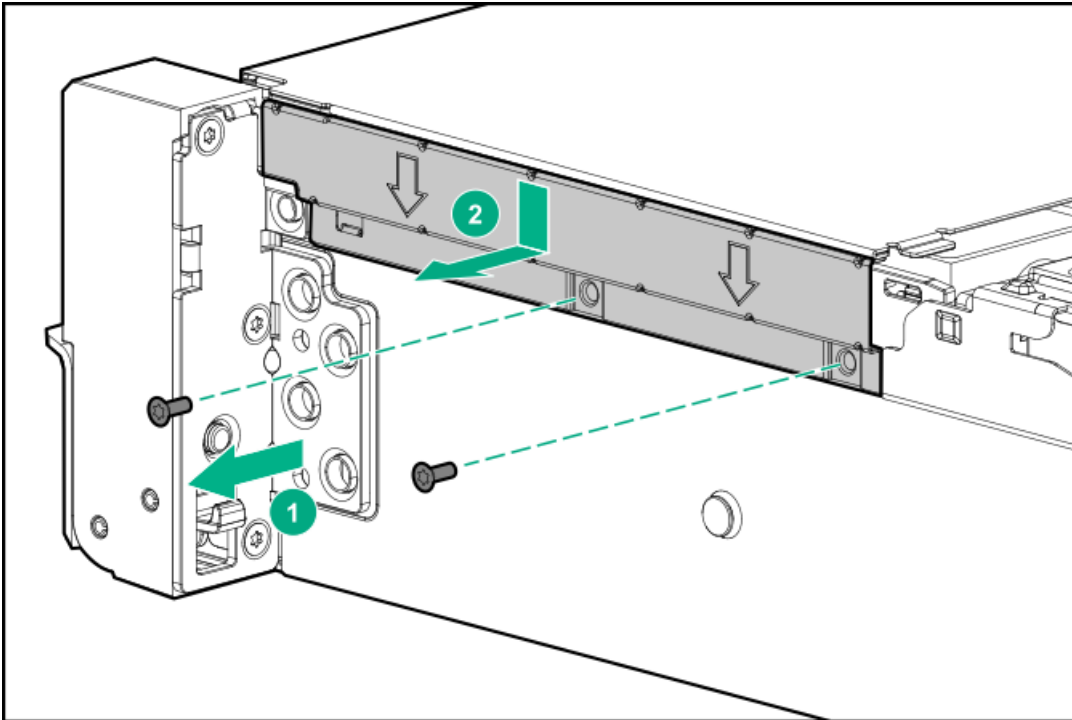

7. Remove the chassis ear.



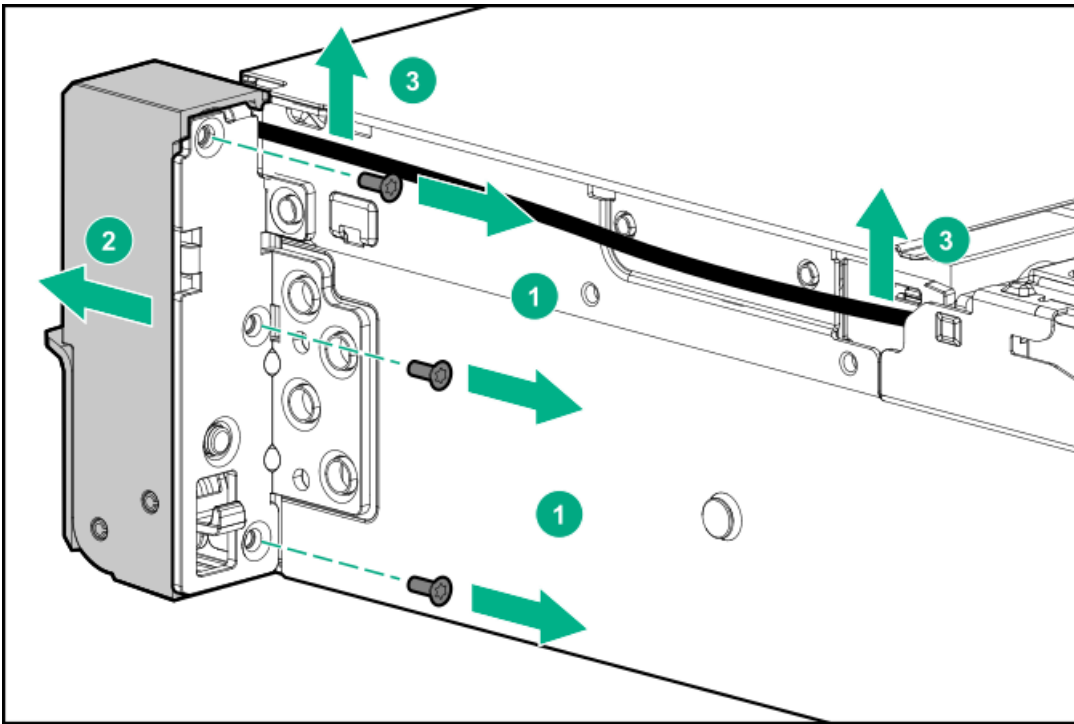

To replace the component, reverse the removal procedure.

Removing and replacing the front I/O board in the LFF right chassis ear

Prerequisites

Before you perform this procedure, make sure that you have the following tools available:

- T-10 Torx screwdriver
- Small flat head screwdriver

Procedure

1. Power down the server.
2. Remove all power:
 - a. Disconnect each power cord from the power source.
 - b. Disconnect each power cord from the server.
3. Remove the server from the rack.
4. Remove the access panel.
5. Remove the cable protection panel.

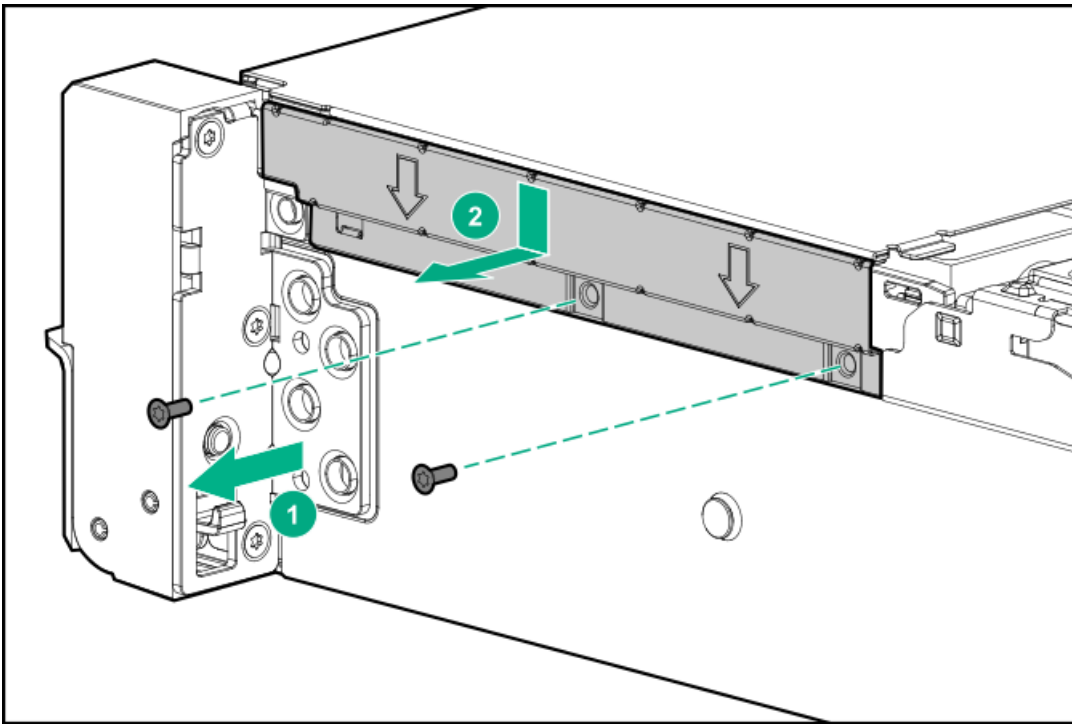

6. To allow some cable slack for disengaging the right chassis ear, detach the power switch cable from the side of the chassis.
7. Disengage the right chassis ear:
 - a. Remove the screws behind the chassis ear.
 - b. Pull up on the chassis ear.
 - c. Rotate the chassis ear open.

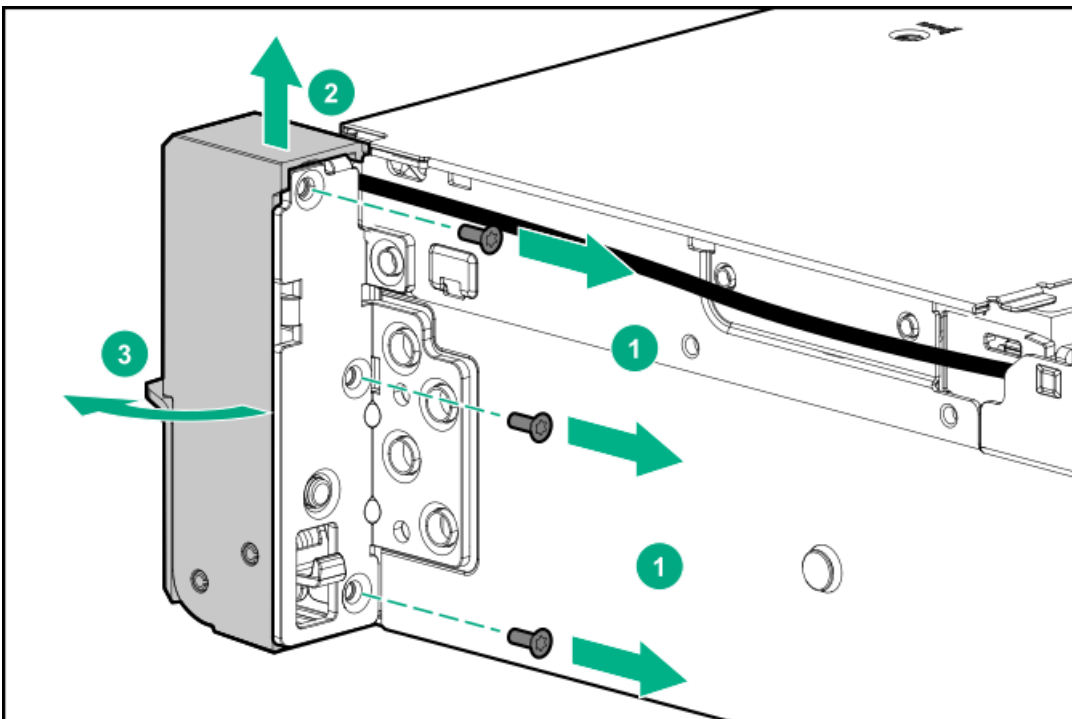

8. Remove the front I/O board from the right chassis ear.



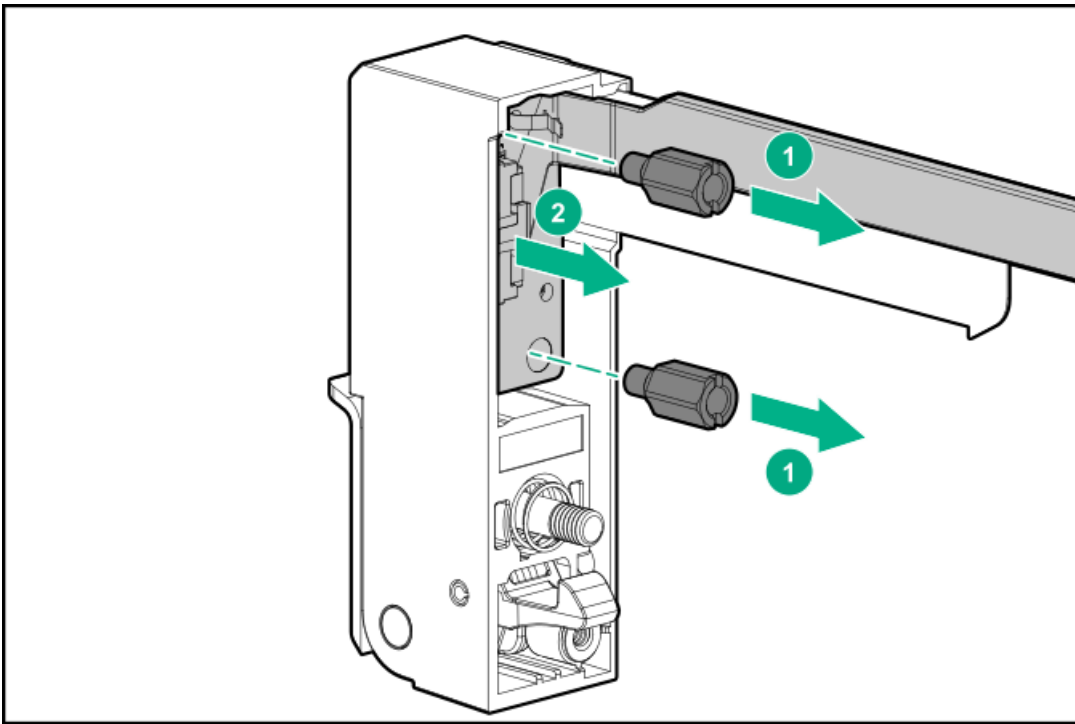

9. Press and hold the cable latch, and then disconnect the power switch cable.

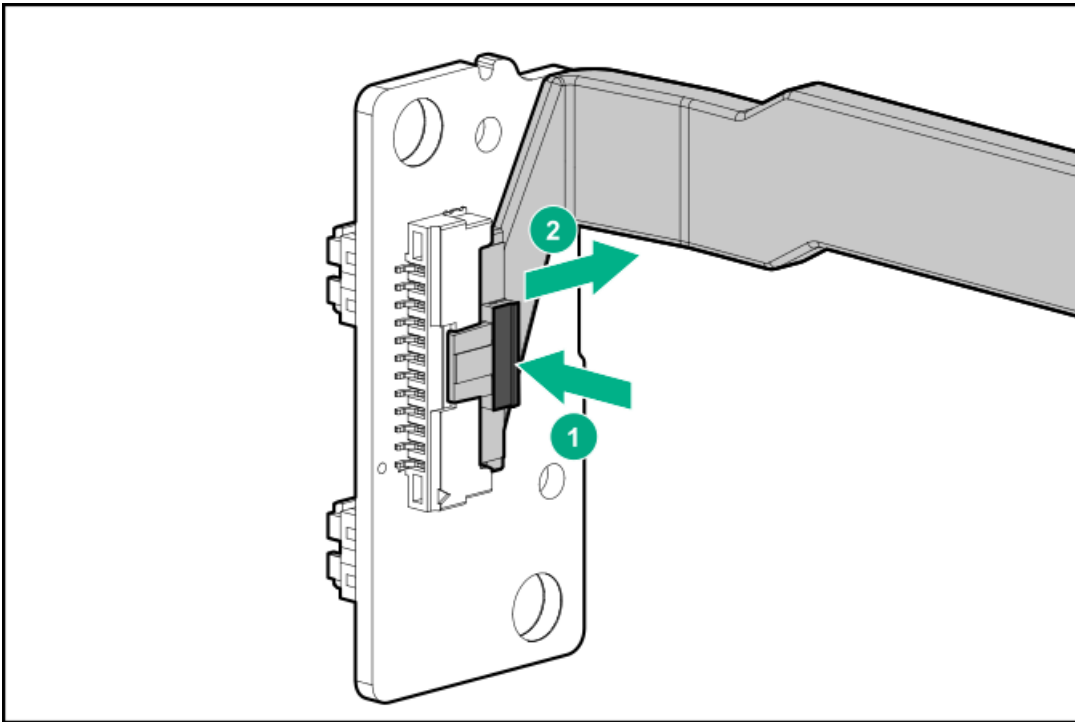

To replace the component, reverse the removal procedure.

Removing and replacing the chassis intrusion detection switch

Procedure

1. Power down the server.
2. Remove all power:
 - a. Disconnect each power cord from the power source.
 - b. Disconnect each power cord from the server.

3. Remove the server from the rack.
4. Remove the access panel.
5. Remove the chassis intrusion detection switch.

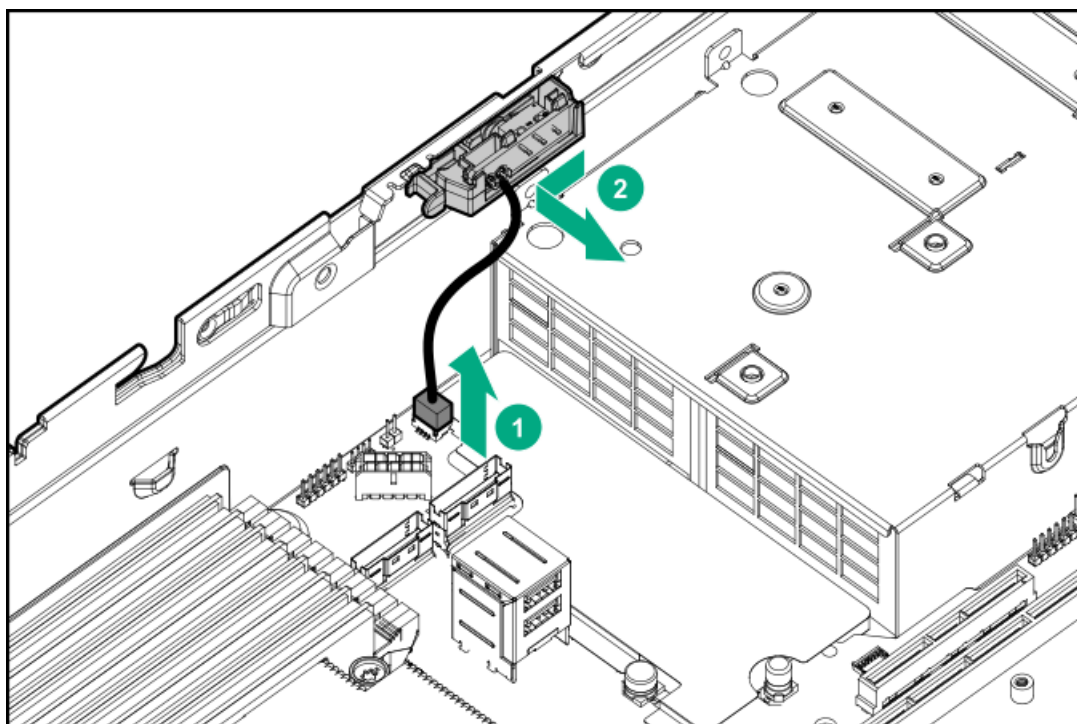

To replace the component, reverse the removal procedure.

Removing and replacing a DIMM

To identify the DIMMs installed in the server, see [DIMM slot locations](#).

Procedure

1. Power down the server.
2. Remove all power:
 - a. Disconnect each power cord from the power source.
 - b. Disconnect each power cord from the server.
3. Do one of the following:
 - Extend the server from the rack.
 - Remove the server from the rack.
4. Remove the access panel.
5. Do one of the following:
 - Remove the air baffle.
 - Remove the midplane drive cage.
6. Remove the DIMM.

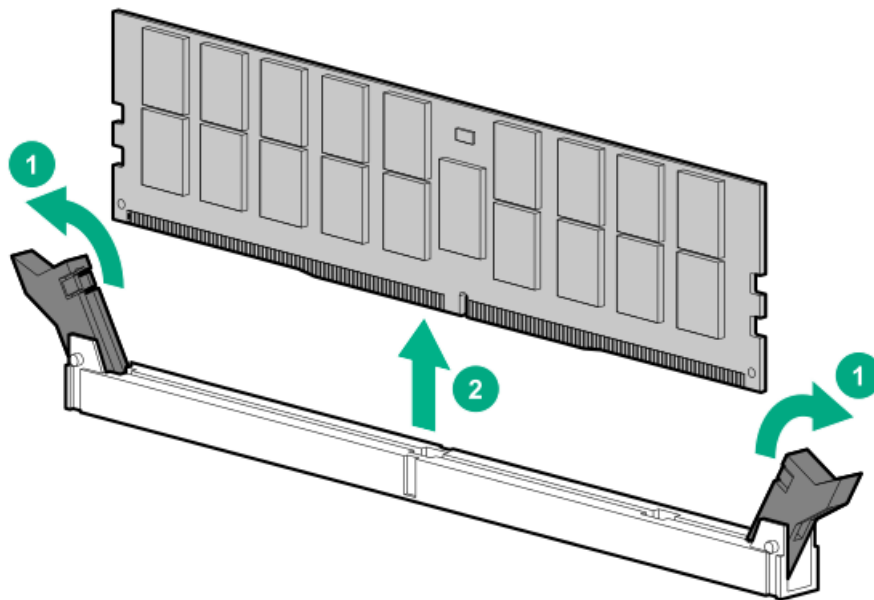

To replace the component, reverse the removal procedure.

For DIMM configuration information, see the server user guide.

Removing a DIMM or persistent memory module

CAUTION:
Electrostatic discharge can damage electronic components. Be sure you are properly grounded before beginning this procedure.

CAUTION:
Failure to properly handle DIMMs can cause damage to DIMM components and the system board connector.

For server-specific steps used in this procedure, see the server maintenance and service guide for your product on the Hewlett Packard Enterprise website:

- HPE ProLiant Gen10 Plus servers (<https://www.hpe.com/info/proliantgen10plus-docs>)
- HPE Synergy Gen10 Plus compute modules (<https://www.hpe.com/info/synergy-docs>)

Prerequisites

- Before handling or removing a DIMM or persistent memory module, see the [Persistent memory module handling guidelines](#).
- If the persistent memory modules are encrypted, you must disable encryption before replacing a failed persistent memory module.

Procedure

1. If persistent memory module encryption is enabled, disable it.

For more information, see [Disabling encryption for a persistent memory module](#).

2. Power down the server:

- a. Shut down the OS as directed by the OS documentation.
- b. To place the server in standby mode, press the Power On/Standby button.

When the server enters standby power mode, the system power LED changes to amber.

- c. Disconnect the power cords (rack and tower servers).

3. Do one of the following:

- Extend the server from the rack.
 - Remove the server from the rack, if necessary.
 - Remove the server or server blade from the enclosure.
4. Place the server on a flat, level work surface.
 5. Remove the access panel.
 6. Access the DIMM slots.
 7. Remove the DIMM or persistent memory module.

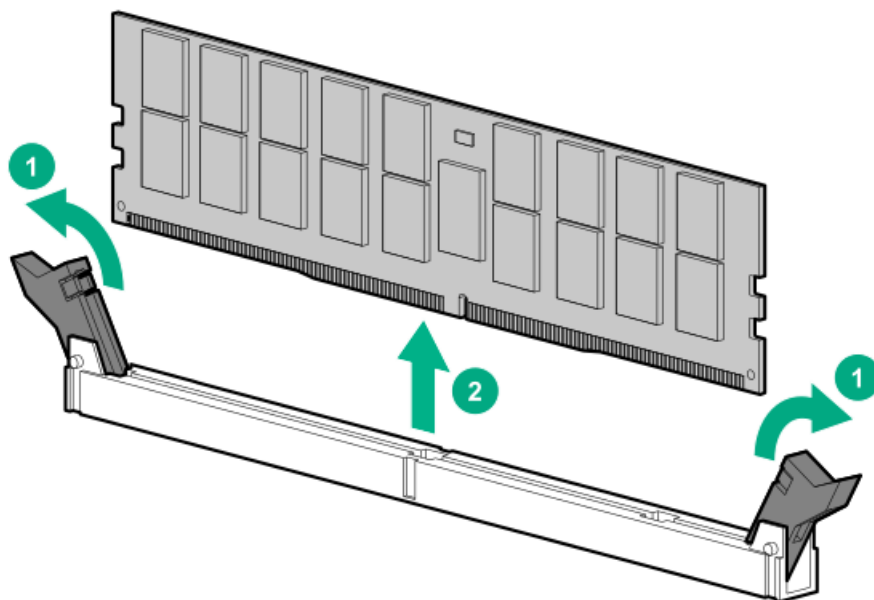

Persistent memory module handling guidelines

⚠ CAUTION:

Failure to properly handle persistent memory modules can damage the component and the system board connector.

When handling a persistent memory module, observe the following guidelines:

- Avoid electrostatic discharge.
- Always hold persistent memory modules by the side edges only.
- Avoid touching the connectors on the bottom of the persistent memory module.
- Never wrap your fingers around a persistent memory module.
- Avoid touching the components on the sides of the persistent memory module.
- Never bend or flex the persistent memory module.

When installing a persistent memory module, observe the following guidelines:

- Before seating the persistent memory module, open the persistent memory module slot and align the persistent memory module with the slot.
- To align and seat the persistent memory module, use two fingers to hold the persistent memory module along the side edges.
- To seat the persistent memory module, use two fingers to apply gentle pressure along the top of the persistent memory module.

For more information, see the Hewlett Packard Enterprise website (<https://www.hpe.com/support/DIMM-20070214-CN>).

Disabling encryption for a persistent memory module

Use this procedure to disable encryption for a single or specific persistent memory modules.

To disable encryption for all persistent memory modules in the server at once, as might be required for migration or service procedures, see [Disabling encryption for a persistent memory module](#).

i IMPORTANT:

Be sure to observe all pop-up messages displayed in UEFI System Utilities that pertain to persistent memory. Failure to follow the instructions in these messages might cause persistent memory data loss.

Procedure

1. From the System Utilities screen, select **System Configuration > BIOS/Platform Configuration (RBSU) > Server Security > Device Encryption Options > Device Encryption Settings > Encrypted Devices**.

2. Make the following selections:

- a. Select **Device**—Select the persistent memory module.
- b. Select **Operation**—Disable Encryption.

3. Select **Start Operation**.

If local key management is enabled, enter the passphrase for the persistent memory module.

The selected persistent memory module is now unencrypted.

4. Repeat this process to disable encryption for other persistent memory modules.

Configuring the server for Intel Optane persistent memory 200 series for HPE

After installing persistent memory modules, configure the server for Intel Optane persistent memory for HPE.

i IMPORTANT:

Always follow recommendations from your software application provider for high-availability best practices to ensure maximum uptime and data protection.

A number of configuration tools are available, including:

- **UEFI System Utilities**—Configure the server by using the UEFI System Utilities through the Remote Console. To access the UEFI System Utilities, press F9 during POST.
- **iLO RESTful API**—Use the iLO RESTful API through tools such as the RESTful Interface Tool (ilorest) or other third-party tools.

For more information, see the Intel Optane persistent memory 200 series for HPE User Guide on the Hewlett Packard Enterprise website (<https://www.hpe.com/info/persistentmemory-docs>).

Removing and replacing an energy pack

Procedure

1. Power down the server.

2. Remove all power:

- a. Disconnect each power cord from the power source.
- b. Disconnect each power cord from the server.

3. Do one of the following:

- [Extend the server from the rack.](#)
 - [Remove the server from the rack.](#)
4. [Remove the access panel.](#)
 5. Do one of the following:
 - [Remove the air baffle.](#)
 - [Remove the midplane drive cage.](#)
 6. [Remove the fan cage.](#)
 7. Disconnect the energy pack cable, and then remove the energy pack.

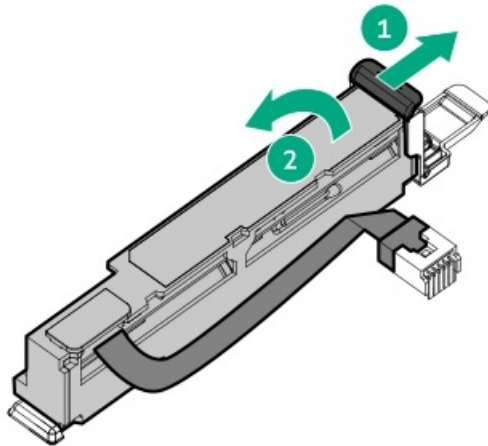

To replace the component, reverse the removal procedure.

Removing and replacing a type-a Smart Array Controller

Procedure

1. Power down the server ([Power down the server](#)).
2. Remove all power:
 - a. Disconnect each power cord from the power source.
 - b. Disconnect each power cord from the server.
3. Do one of the following:
 - Extend the server from the rack ([Extend the server from the rack](#)).
 - Remove the server from the rack ([Remove the server from the rack](#)).
4. Remove the access panel ([Remove the access panel](#)).
5. Do one of the following:
 - Remove the air baffle ([Removing the air baffle](#)).
 - Remove the 4 LFF midplane cage ([Removing and replacing a midplane drive cage](#)).
6. Disconnect the SAS cables.

7. Remove the controller.

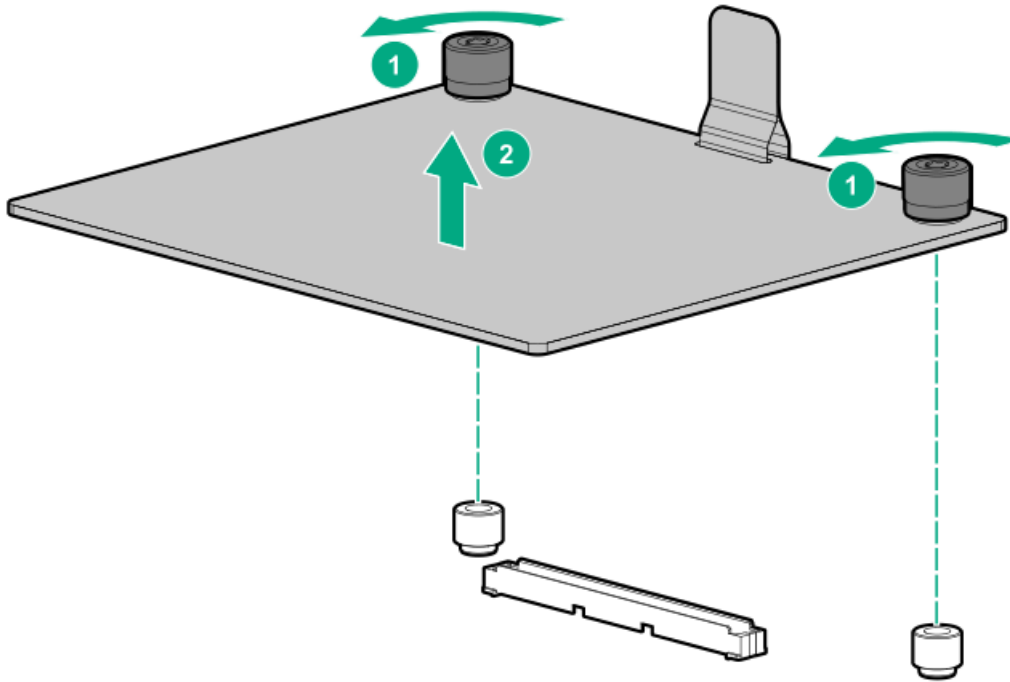

To replace the component, reverse the removal procedure.

Removing and replacing the Pensando DSP DSC-25 2p SFP28 card

Decommissioning the Pensando DSP DSC-25 2p SFP28 card

Procedure

Before removing the DSC-25 card from the server, you must first decommission the card using the Pensando Policy and Services Manager (PSM).

For more information, see Pensando Distributed Services Card for Single-Wire Management (DSC-25-SWM) Removal/Replacement Guide on the Hewlett Packard Enterprise website (<https://www.hpe.com/support/dsc25-replacement>).

Removing the Pensando DSP DSC-25 2p SFP28 card

NOTE:

Images might differ from the actual product.

Prerequisites

The DSC-25 card has been decommissioned.

Procedure

1. Observe the following alerts:

 **WARNING:** To reduce the risk of personal injury from hot surfaces, allow the drives and the internal system components to cool before touching them.

△ CAUTION:

A discharge of static electricity from a finger or other conductor might damage system boards or other static-sensitive devices. To prevent damage, observe antistatic precautions.

△ CAUTION:

To prevent improper cooling and thermal damage, do not operate the server unless all PCI slots have either an expansion slot cover or an expansion board installed.

2. Power down the server.
3. Remove all power:
 - a. Disconnect each power cord from the power source.
 - b. Disconnect each power cord from the server.
4. Do one of the following:
 - Extend the server from the rack.
 - Remove the server from the rack.
5. Remove the access panel.

△ CAUTION: Do not operate the server for long periods with the access panel open or removed. Operating the server in this manner results in improper airflow and improper cooling that can lead to thermal damage.

6. Remove the primary PCIe riser cage.

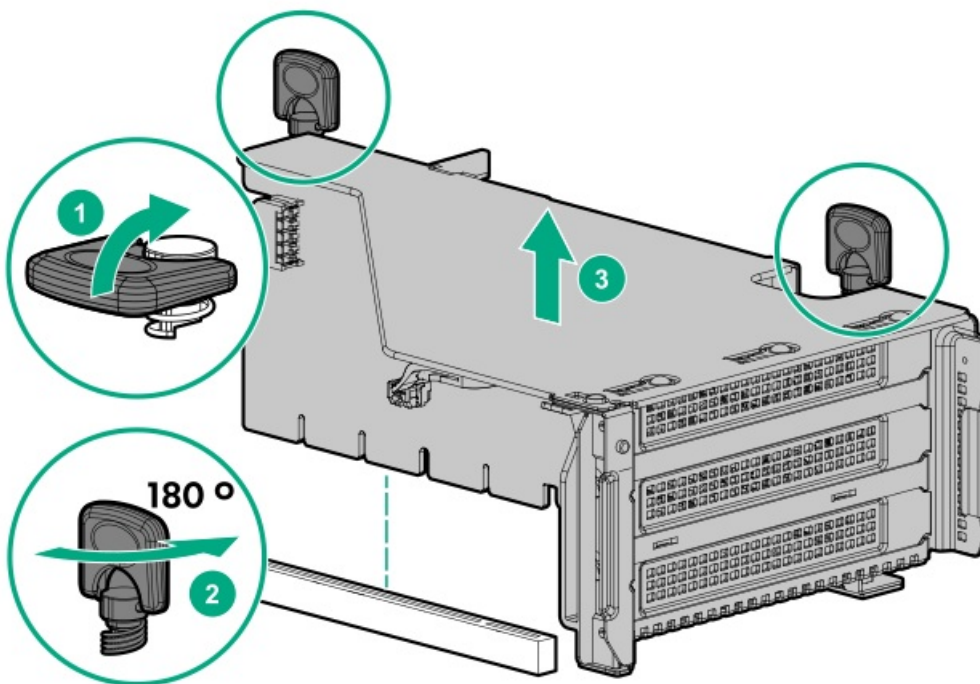

7. Remove the DSC-25 card from the slot.

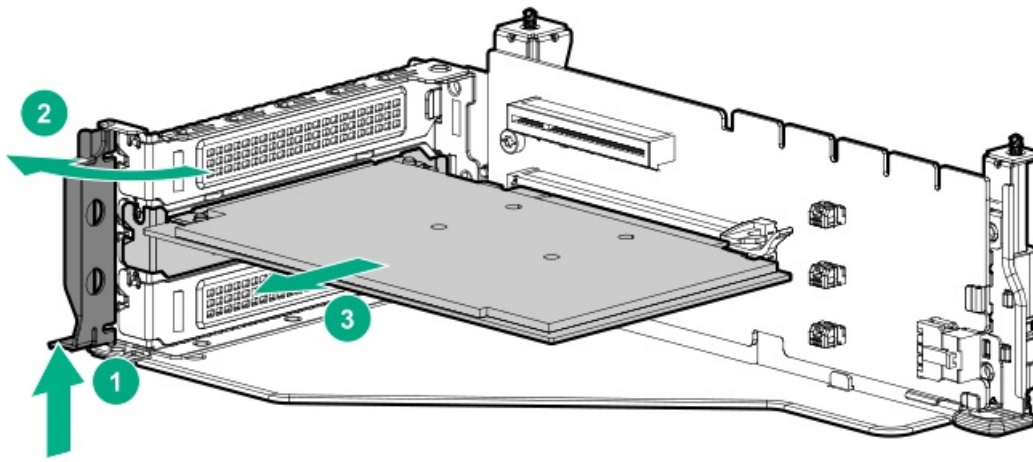

Replacing the Pensando DSP DSC-25 2p SFP28 card

Pensando DSP iLO Sideband ALOM Module requires that the accompanying Smart I/O card (Pensando DSP DSC-25 2p SFP28 card) be installed on slot 1 of the primary PCIe riser cage.

Procedure

1. Install the DSC-25 card into the PCIe slot:

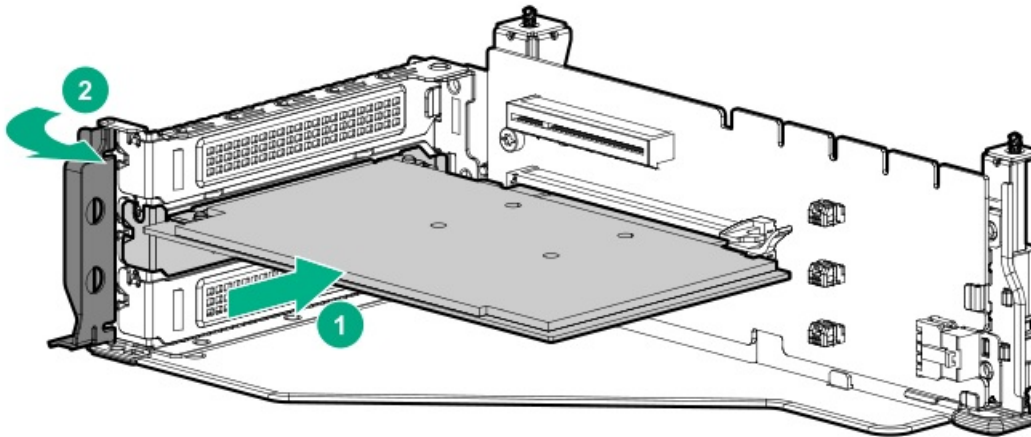

2. Install the PCIe riser cage into the server.

△ CAUTION:

Do not twist the cable service loop during installation.

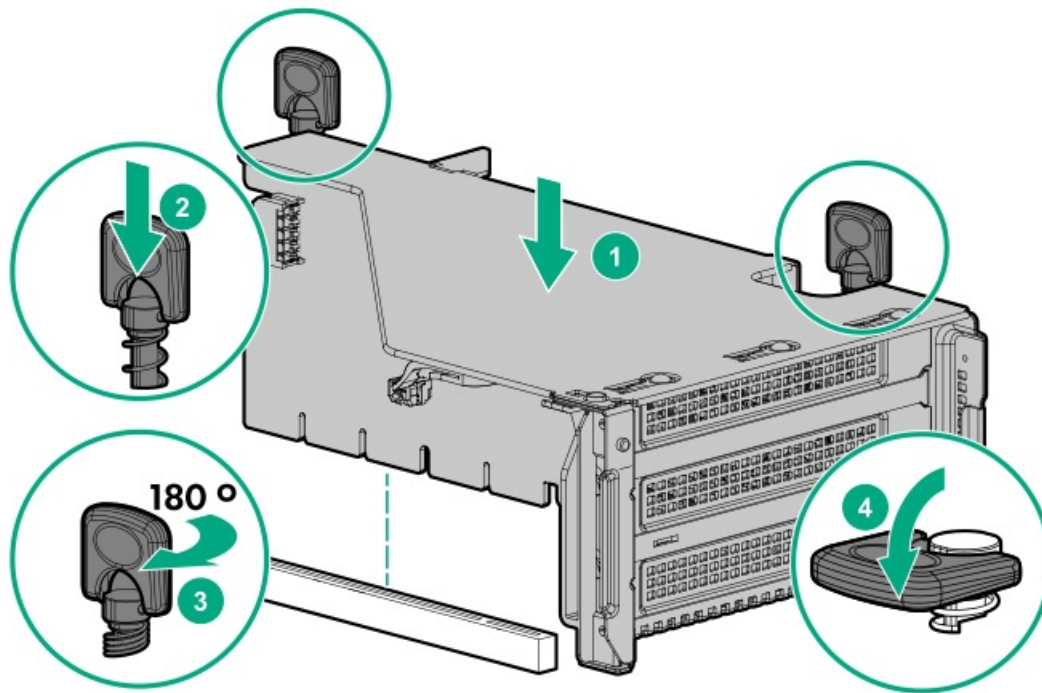

3. Install the access panel.
4. Slide the server into the rack.
5. Connect each power cord to the server.
6. Connect each power cord to the power source.
7. Power up the server.
8. Admit the new card to the Pensando Policy and Services Manager (PSM).

For more information, see the replacement instructions for the card on the Hewlett Packard Enterprise website

<https://www.hpe.com/support/hpesc>

Removing and replacing the HPE NS204i-p NVMe OS Boot Device option

Removing and replacing the boot device

Prerequisites

Procedure

1. Observe the following alerts:

⚠ CAUTION:

The boot device and the drives installed on the boot device are not hot-pluggable. To remove the boot device, or a drive from the boot device, you must first power down the server.

⚠ WARNING: To reduce the risk of personal injury from hot surfaces, allow the drives and the internal system components to cool before touching them.

2. Back up all server data.
3. Power down the server.

4. Remove all power:
 - a. Disconnect each power cord from the power source.
 - b. Disconnect each power cord from the server.
5. Do one of the following:
 - Extend the server from the rack.
 - Remove the server from the rack.
 - Remove the compute module from the enclosure.
6. Place the server on a flat, level work surface.
7. Remove the access panel.
8. Remove the primary PCIe riser cage.
9. Remove the boot device.

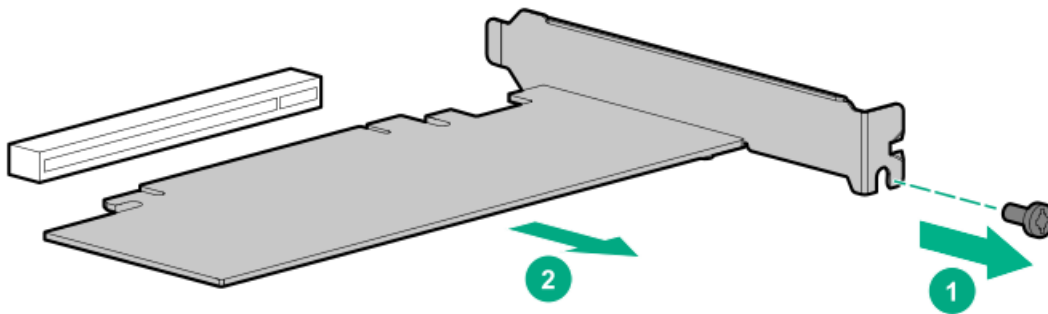

10. Remove the drives from the boot device.

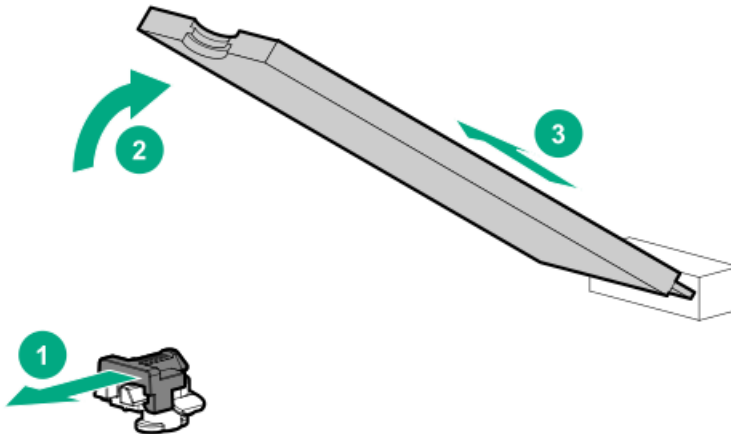

Retain these drives for installation onto the replacement boot device.

To replace the component, reverse the removal procedure.

Removing and replacing a boot device drive

The boot device supports two physical drive sizes:

- 22110 (110 mm)
- 2280 (80 mm)

Two drives of the same physical size, or one of each size, can be installed at the same time. Depending on the replacement drive size,

you might need to [relocate the M.2 drive retaining latches](#) on the boot device.

Prerequisites

Review the [boot device drive bay LEDs](#) to determine the failed drive.

Procedure

1. Observe the following alerts:

⚠ CAUTION:

The boot device and the drives installed on the boot device are not hot-pluggable. To remove the boot device, or a drive from the boot device, you must first power down the server.

⚠ WARNING: To reduce the risk of personal injury from hot surfaces, allow the drives and the internal system components to cool before touching them.

2. Back up all server data.
3. Power down the server.
4. Remove all power:
 - a. Disconnect each power cord from the power source.
 - b. Disconnect each power cord from the server.
5. Do one of the following:
 - Extend the server from the rack ([Extend the server from the rack](#)).
 - Remove the server from the rack ([Remove the server from the rack](#)).
 - Remove the compute module from the enclosure.
6. Place the server on a flat, level work surface.
7. Remove the access panel, if necessary ([Remove the access panel](#)).
8. Remove the PCIe riser cage, if necessary ([Removing and replacing the primary PCIe riser cage](#)).
9. Remove the boot device.

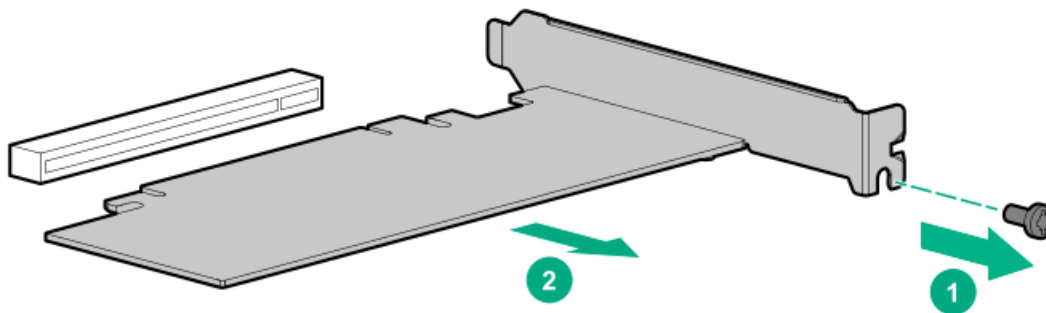

10. Remove the failed drive from the boot device.

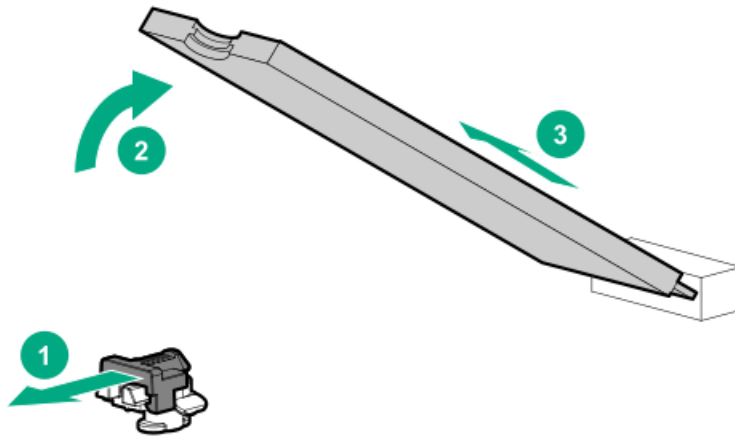

To replace the component, reverse the removal procedure.

Relocating the M.2 drive retaining latches

Procedure

1. If your spare kit includes an 80 mm replacement drive, remove the retaining latch from its current location.

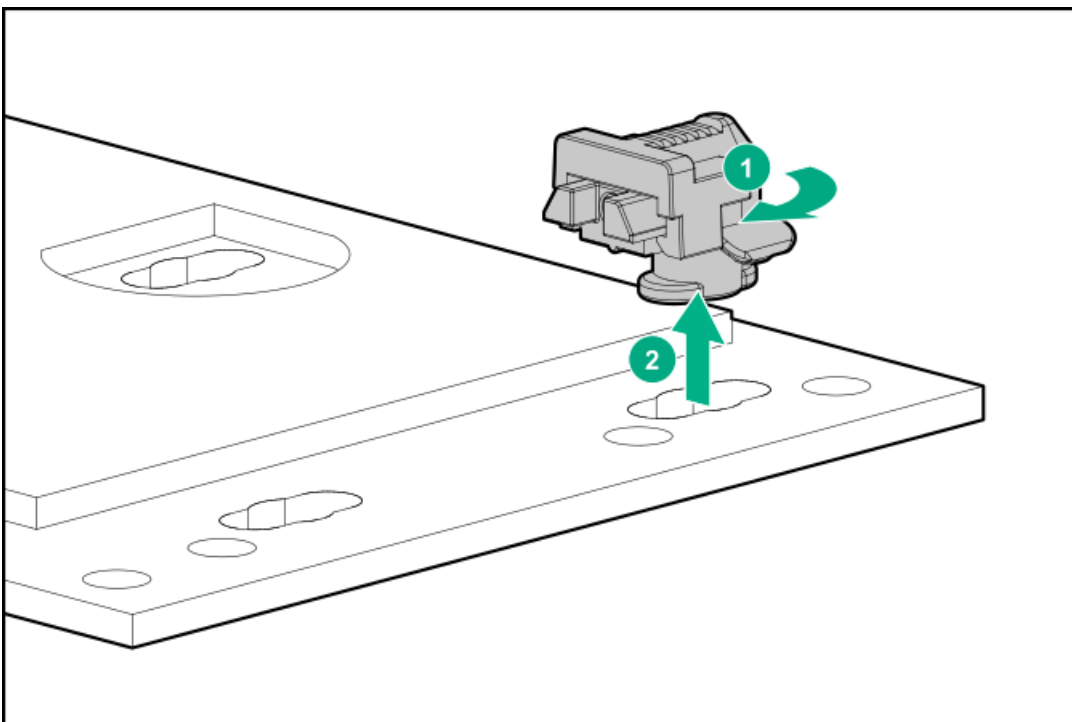

2. Install the retaining latch at the 80 mm drive location.

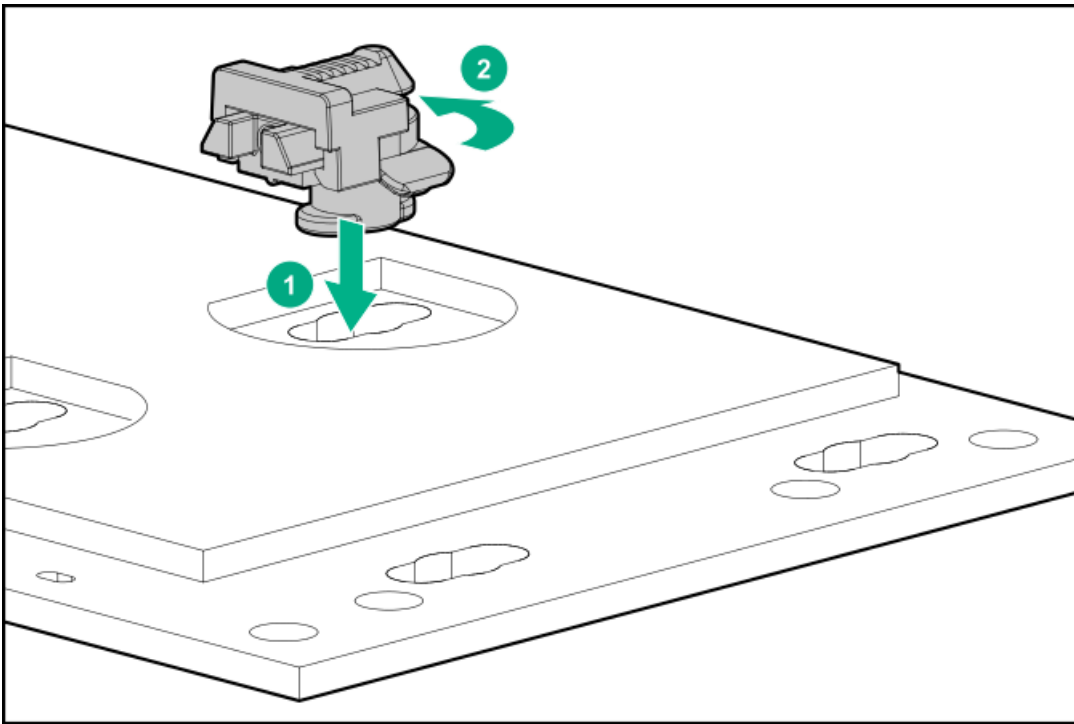

Removing and replacing a processor or heatsink

Prerequisites

Before you perform this procedure, make sure that you have the following items available:

- The components included with the spare kit
- Thermal grease
- T-30 Torx screwdriver

Procedure

1. Observe the following alerts.

⚠ **CAUTION:** When handling the heatsink, always hold it along the top and bottom of the fins. Holding it from the sides can damage the fins.

⚠ **CAUTION:** To prevent possible server malfunction and damage to the equipment, multiprocessor configurations must contain processors with the same part number.

⚠ **CAUTION:** If installing a processor with a faster speed, update the system ROM before installing the processor. To download firmware and view installation instructions, see the [Hewlett Packard Enterprise Support Center website](#).

2. Power down the server.
3. Remove all power:
 - a. Disconnect each power cord from the power source.
 - b. Disconnect each power cord from the server.
4. Do one of the following:

- a. Extend the server from the rack.
 - b. Remove the server from the rack.
5. Remove the access panel.
 6. Remove any components or cables that may prevent access to the processor heatsink assembly.
 7. Observe the following cautions.

△ CAUTION: Install the processor heatsink assembly as soon as possible after removing it. Do not leave the processor socket unpopulated for extended periods of time.

8. Remove the processor heatsink assembly from the socket:
 - a. Allow the heatsink to cool.
 - b. Using a T-30 Torx screwdriver, loosen the heatsink nuts.

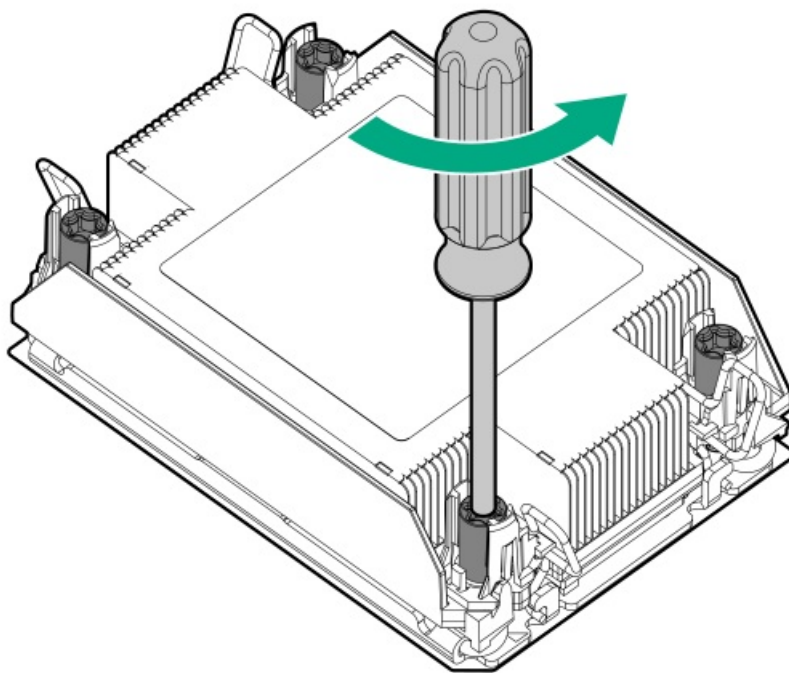

- c. Lift the processor heatsink assembly up and away from the system board.

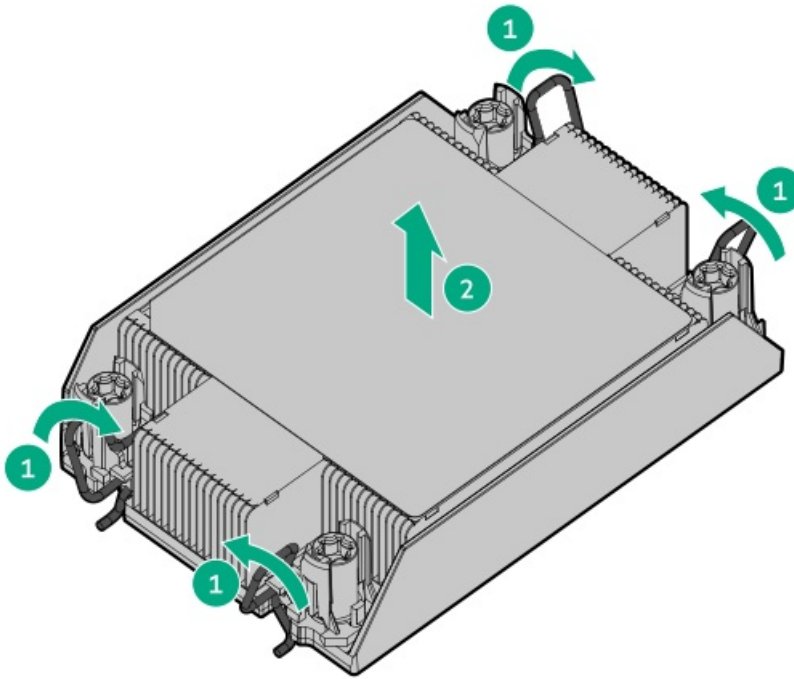

- d. Turn the processor heatsink assembly over and place it on a work surface with the processor assembly facing up.
 - e. Install the dust cover.
9. Separate the processor assembly and heatsink.

⚠ **CAUTION: THE CONTACTS ARE VERY FRAGILE AND EASILY DAMAGED.** To avoid damage to the socket or processor, do not touch the contacts.

⚠ **CAUTION:** The processor assembly must be removed and replaced as a unit. Do not remove the processor from the carrier.

The TIM breaker is on the processor carrier and releases the adhesion between the processor and the heatsink.

⚠ **CAUTION:** After the TIM breaker is used, the processor might become unlatched from the carrier. To avoid damage to the processor, handle the processor assembly carefully.

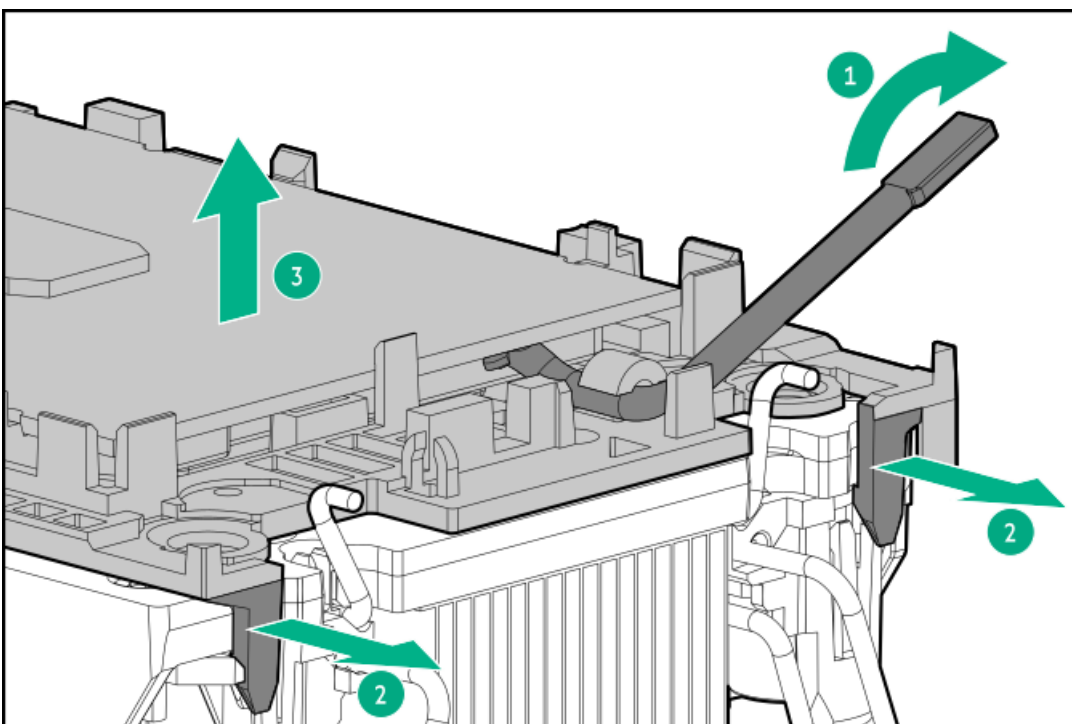

10. Using a cleaning solvent, such as alcohol wipes, remove the existing thermal grease from the processor and heatsink.

11. Apply a full thermal grease syringe to the new processor.

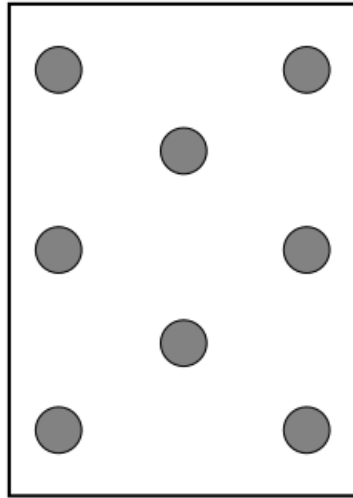

If installing a new heatsink, the thermal grease is preapplied.

12. Install the processor assembly on the heatsink.

Align the Pin 1 indicators on the processor and heatsink, and then latch the processor assembly to the heatsink.

Your processor assembly or heatsink or both may look different than the one shown.

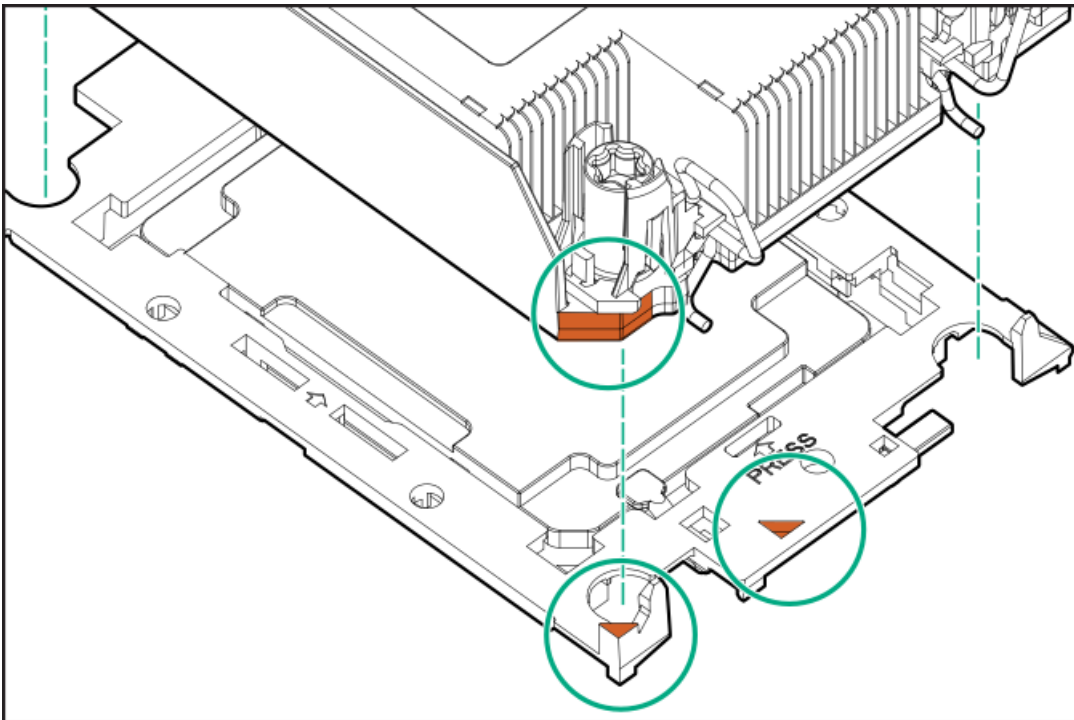

13. Install the processor heatsink assembly:

- a. Identify the front of the server label on the heatsink.
- b. Align the processor heatsink assembly with the alignment pins and gently install it evenly on the socket.

Be sure the latches lock the heatsink into place. The heatsink alignment posts are keyed. The processor will only install one way.

Your heatsink may look different than the one shown.



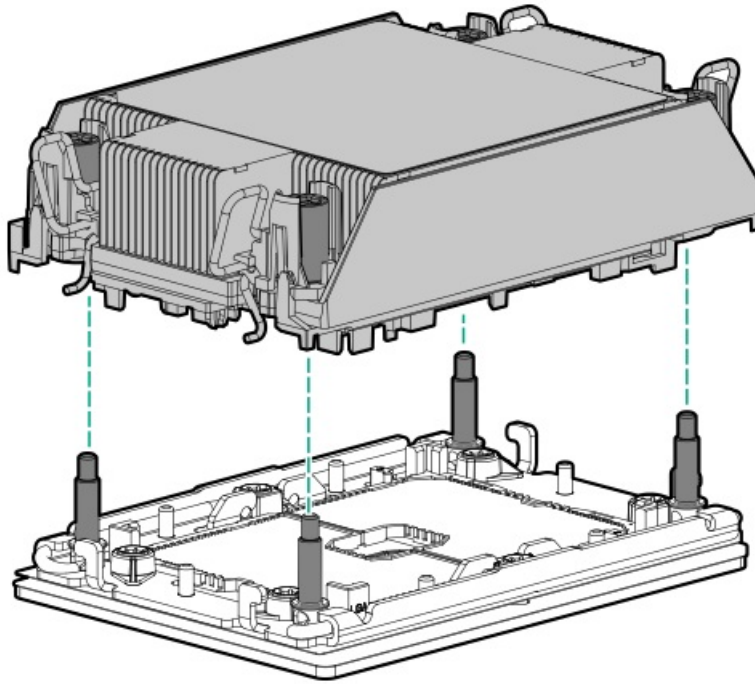

c. Tighten the nuts.

 **NOTE:** Do not tighten the nuts to more than 12 in-lbs or 1.3Nm. Over tightening the nuts, could crack or damage the nuts.

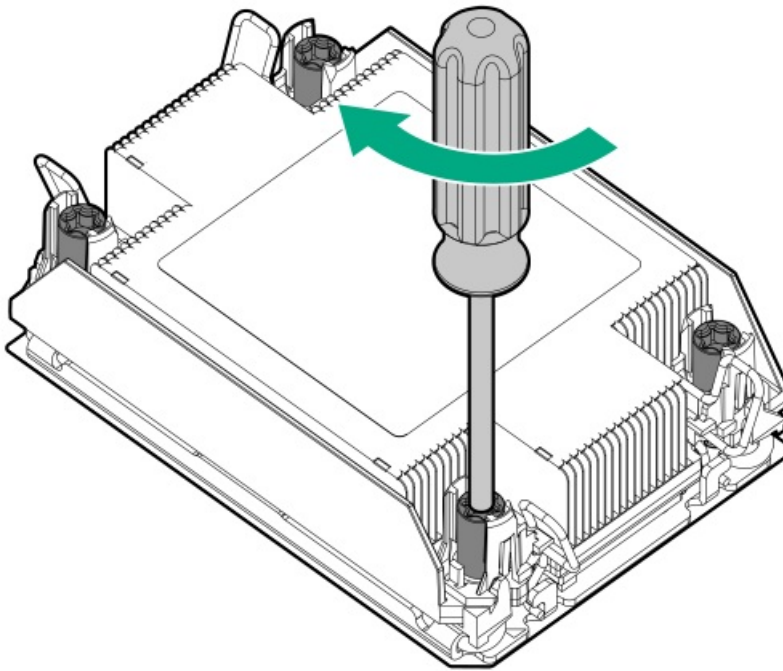

Removing and replacing the system battery

The system battery provides power to the real-time clock. If the server no longer automatically displays the correct date and time, you might need to replace the system battery.

 **WARNING:** The computer contains an internal lithium manganese dioxide, a vanadium pentoxide, or an alkaline battery pack. A risk of fire and burns exists if the battery pack is not properly handled. To reduce the risk of personal injury:

- Do not attempt to recharge the battery.

- Do not expose the battery to temperatures higher than 60°C (140°F).
- Do not expose the battery to extremely low air pressure as it might lead to explosion or leakage of flammable liquid or gas.
- Do not disassemble, crush, puncture, short external contacts, or dispose of in fire or water.
- Replace only with the spare designated for this product.

Procedure

1. Power down the server ([Power down the server](#)).
2. Remove all power:
 - Disconnect each power cord from the power source.
 - Disconnect each power cord from the server.
3. Do one of the following:
 - Extend the server from the rack ([Extend the server from the rack](#)).
 - Remove the server from the rack ([Remove the server from the rack](#)).
4. Remove the access panel ([Remove the access panel](#)).
5. If installed, remove the tertiary PCIe riser cage ([Removing and replacing the secondary and tertiary PCIe riser cages](#)).
6. Locate the battery ([System board components](#)).
7. Remove the battery.

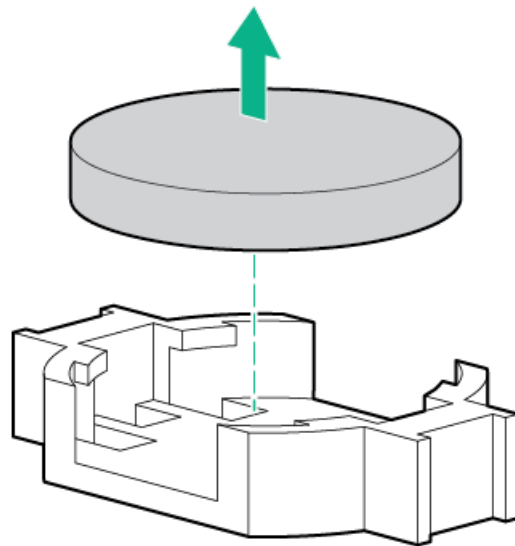

8. To replace the component, reverse the removal procedure.
9. Properly dispose of the old battery.

For more information about battery replacement or proper disposal, contact an authorized reseller or an authorized service provider.

Removing and replacing the system board

Prerequisites

If persistent memory modules are installed in the server and are encrypted with local key management, do one of the following:

- Manually retrieve the persistent memory module passwords from the server (user-generated passwords only)
- Export a password file to a USB key.

Hewlett Packard Enterprise recommends exporting the password file to a USB key.

For more information, see the Intel Optane persistent memory 200 series for HPE User Guide on the Hewlett Packard Enterprise website (<https://www.hpe.com/info/persistentmemory-docs>).

Procedure

Removing the system board

1. Power down the server.
2. Remove all power:
 - a. Disconnect each power cord from the power source.
 - b. Disconnect each power cord from the server.
3. Remove the server from the rack.
4. Remove all power supplies.
5. Remove the access panel.
6. Do one of the following:
 - Remove the air baffle.
 - Remove the midplane drive cage.
7. Remove the primary or secondary PCIe riser cage.
8. If installed, remove the tertiary PCIe riser cage .
9. Remove the OCP 3.0 adapter.
10. Remove all DIMMs.

Be sure to note the DIMM slot locations in which each DIMM is installed. These components must be installed in the same locations on the new system board.

11. Remove the persistent memory modules installed on the system board .

Be sure to note the DIMM slot locations in which each persistent memory module is installed. These components must be installed in the same locations on the new system board.

12. Remove the fan cage.
13. Disconnect all cables connected to the system board.
14. Observe the following cautions.

 **CAUTION:** Be sure to loosen each heatsink nut in the order indicated. Otherwise, damage might occur to the heatsink or processor.

 **CAUTION:** Install the processor heatsink assembly as soon as possible after removing it. Do not leave the processor socket unpopulated for extended periods of time.

15. Remove the processor-heatsink assembly.
16. Remove the processor heatsink assembly:
 - a. Allow the heatsink to cool.
 - b. Using a T-30 Torx screwdriver, loosen the heatsink nuts.

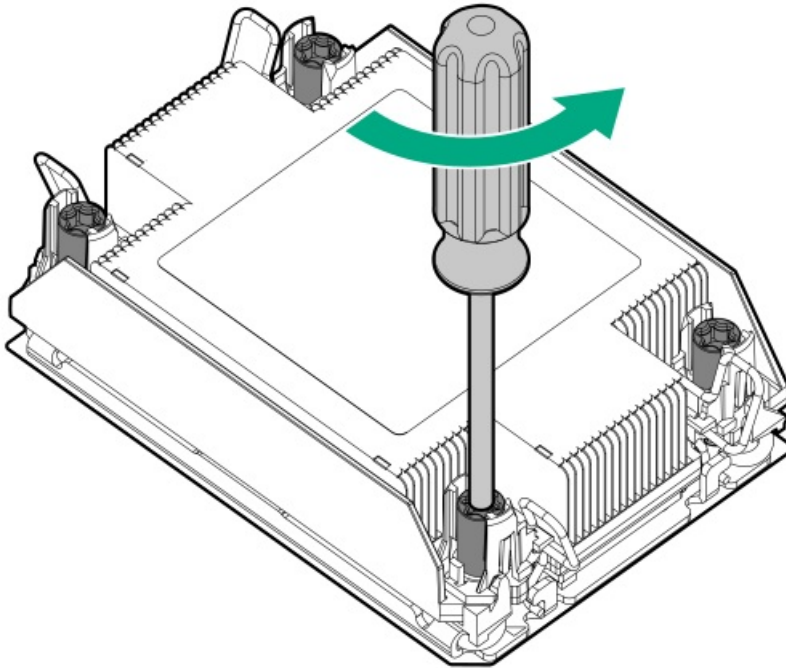

c. Lift the processor heatsink assembly up and away from the system board.

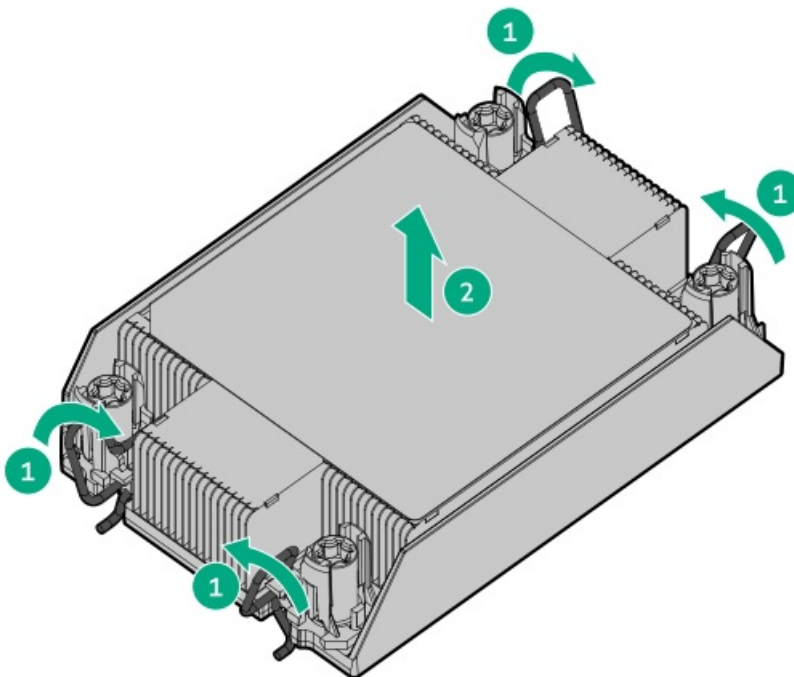

d. Turn the processor heatsink assembly over and place it on a work surface with the processor assembly facing up.

e. Install the dust cover.

17. Loosen the system board thumbscrews.

18. Remove the system board, using the handle to lift it out of the chassis.



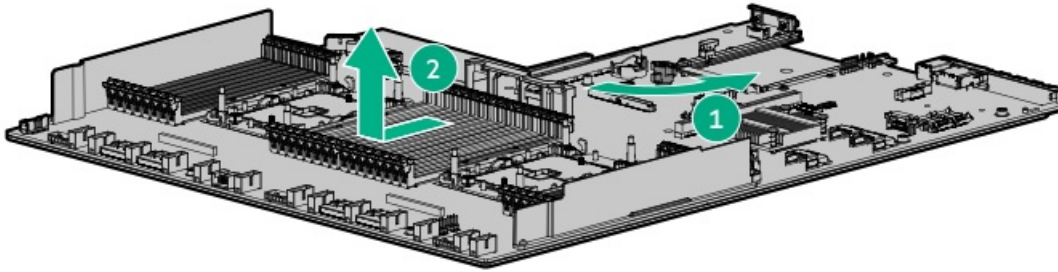

Replacing the system board

19. Install the spare system board.

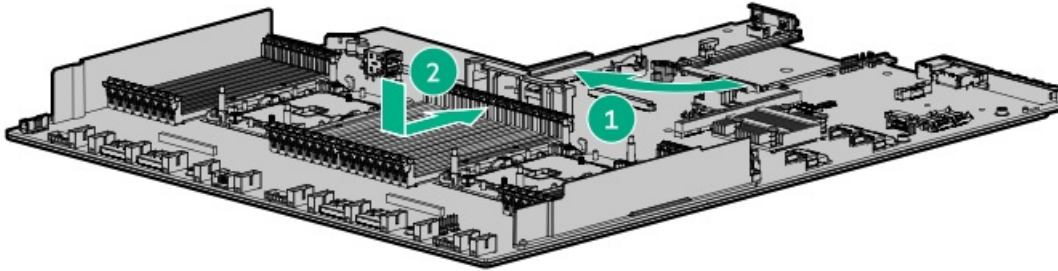

20. Install the processor-heatsink assembly:

- a. Identify the front of the server label on the heatsink.
- b. Align the processor heatsink assembly with the alignment pins and gently install it evenly on the socket.

Be sure the latches lock the heatsink into place. The heatsink alignment posts are keyed. The processor will only install one way.

Your heatsink may look different than the one shown.

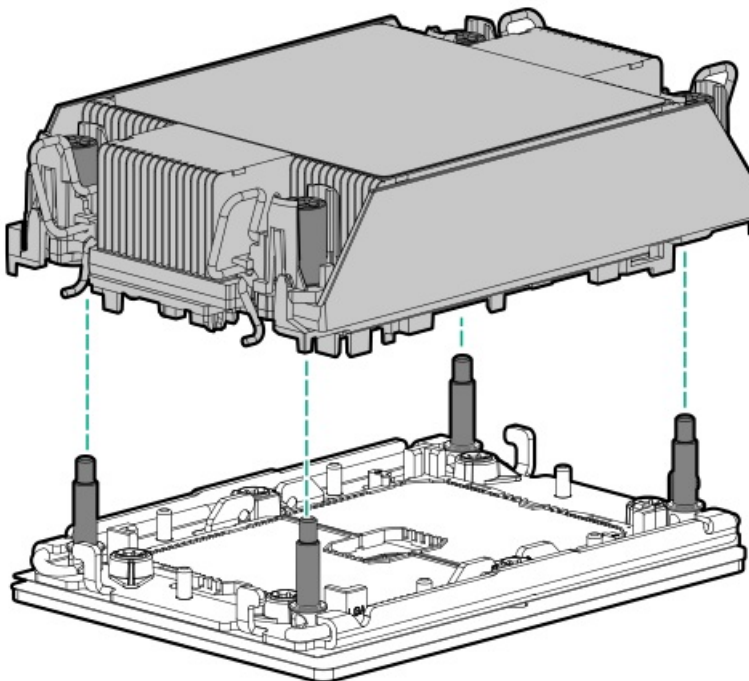

- c. Tighten the nuts.

NOTE: Do not tighten the nuts to more than 12 in-lbs or 1.3Nm. Over tightening the nuts, could crack or damage the nuts.

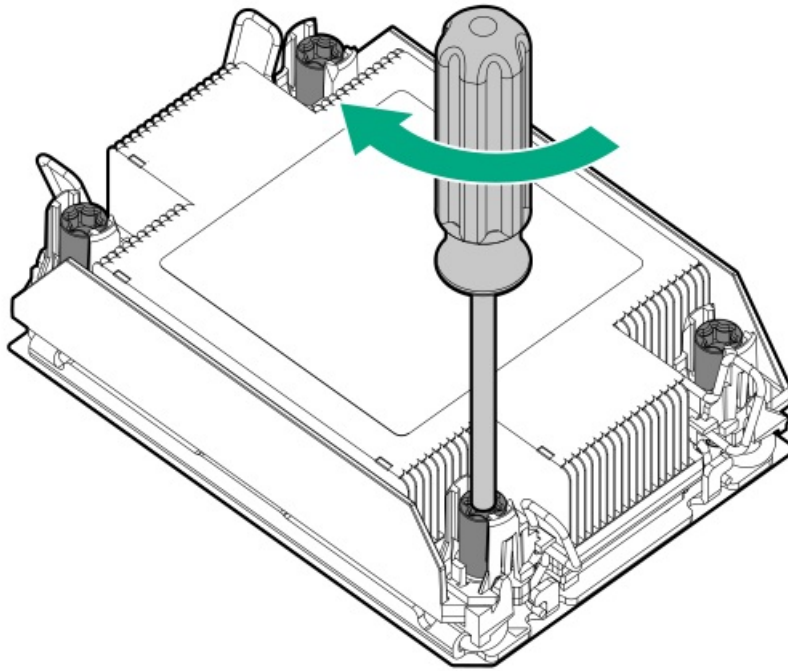

21. Install all components removed from the failed system board.

Be sure to install the DIMMs and persistent memory modules in the same DIMM slots as the failed system board.

22. Install the access panel.
23. Install the power supplies.
24. Power up the server.
25. Ensure all firmware, including option cards and embedded devices, is updated to the same versions to ensure that the latest drivers are being used.
26. Re-enter any Secure Boot Keys that were previously added in the Secure Boot configuration.
27. Re-enter the server serial number and the product ID.
28. Review the persistent memory configuration of the server.

For more information, see [Configuring the server for Intel Optane persistent memory 200 series for HPE.](#)

29. Do one of the following:

- If persistent memory modules are encrypted with local key management, either manually enter the persistent memory module passwords in the System Utilities or import the password file from the USB key.
- If persistent memory modules are encrypted with remote key management, enroll the server iLO in the key management server to provide access to the data on the persistent memory modules.

For more information, see the Intel Optane persistent memory 200 series for HPE User Guide on the Hewlett Packard Enterprise website (<https://www.hpe.com/info/persistentmemory-docs>).

Re-entering the server serial number and product ID

After you replace the system board, the server serial number and the product ID must be configured:

Procedure

1. Access System Utilities. During POST, press F9.
2. On the System Utilities home screen, select System Configuration > BIOS/Platform Configuration (RBSU) > Advanced Options > Advanced Service Options.

3. Select the Serial Number field and press Enter.

The following alert appears:

```
The serial number is modified by qualified service personnel and must match the serial number located on the chassis.
```

4. Click OK.
5. Type the serial number and press Enter.
6. From the System Utilities screen, select System Configuration > BIOS/Platform Configuration (RBSU) > Date and Time.
7. Select a setting, and then complete your entry:
 - Date (mm-dd-yyyy)—Enter the date in a month-day-year (mm-dd-yyyy) format.
 - Time (hh:mm:ss)—Enter the time in a 24-hour format (hh:mm:ss) format.
 - Time Zone—Select your current time zone for the system.
 - Daylight Savings Time:
 - Enabled—Adjusts the local time displayed by one hour for Daylight Savings Time.
 - Disabled—Does not adjust the local time displayed for Daylight Savings Time.
 - Time Format
 - Coordinated Universal Time (UTC) — Calculates the time stored in the hardware Real Time Clock (RTC) from the associated Time Zone setting.
 - Local Time—Removes the use of the Time Zone setting.

This option is useful for addressing interaction issues between Windows operating systems set in Legacy BIOS boot mode.

8. Save your settings.
9. Select the Product ID field and press Enter.

The following alert appears:

```
Product ID is modified only by qualified personnel. This value must match the product ID located on the chassis.
```

10. Type the product ID and press Enter.
11. Press F10 to save the configuration.

The procedure is complete.

HPE Trusted Platform Module 2.0 Gen10 Plus option

The option is not a customer-removable part.

CAUTION: If the TPM is removed from the original server and powered up on a different server, data stored in the TPM including keys will be erased.

If you suspect a TPM board failure, leave the TPM installed and remove the system board ([Removing and replacing the system board](#)). Contact a Hewlett Packard Enterprise authorized service provider for a replacement system board and TPM module.

Troubleshooting

Troubleshooting resources

Troubleshooting resources are available for HPE Gen10 and Gen10 Plus server products in the following documents:

- Troubleshooting Guide for HPE ProLiant Gen10 and Gen10 Plus servers provides procedures for resolving common problems and comprehensive courses of action for fault isolation and identification, issue resolution, and software maintenance.
- Error Message Guide for HPE ProLiant Gen10 Plus servers and HPE Synergy provides a list of error messages and information to assist with interpreting and resolving error messages.
- Integrated Management Log Messages and Troubleshooting Guide for HPE ProLiant Gen10 and Gen10 Plus servers and HPE Synergy provides IML messages and associated troubleshooting information to resolve critical and cautionary IML events.

To access troubleshooting resources for your product, see the [Hewlett Packard Enterprise website](#).

Diagnostic tools

UEFI System Utilities

The UEFI System Utilities is embedded in the system ROM. Its features enable you to perform a wide range of configuration activities, including:

- Configuring system devices and installed options.
- Enabling and disabling system features.
- Displaying system information.
- Selecting the primary boot controller or partition.
- Configuring memory options.
- Launching other preboot environments.

HPE servers with UEFI can provide:

- Support for boot partitions larger than 2.2 TB. Such configurations could previously only be used for boot drives when using RAID solutions.
- Secure Boot that enables the system firmware, option card firmware, operating systems, and software collaborate to enhance platform security.
- UEFI Graphical User Interface (GUI)
- An Embedded UEFI Shell that provides a preboot environment for running scripts and tools.
- Boot support for option cards that only support a UEFI option ROM.

Selecting the boot mode

This server provides two Boot Mode configurations: UEFI Mode and Legacy BIOS Mode. Certain boot options require that you select a specific boot mode. By default, the boot mode is set to UEFI Mode. The system must boot in UEFI Mode to use certain options, including:

- Secure Boot, UEFI Optimized Boot, Generic USB Boot, IPv6 PXE Boot, iSCSI Boot, NVMe Boot and Boot from URL
- Fibre Channel/FCoE Scan Policy

 **NOTE:**

The boot mode you use must match the operating system installation. If not, changing the boot mode can impact the ability of the server to boot to the installed operating system.

Prerequisite

When booting to UEFI Mode, leave UEFI Optimized Boot enabled.

Procedure

1. From the System Utilities screen, select System Configuration > BIOS/Platform Configuration (RBSU) > Boot Options > Boot Mode.
2. Select a setting.
 - UEFI Mode (default)—Configures the system to boot to a UEFI compatible operating system.
 - Legacy BIOS Mode—Configures the system to boot to a traditional operating system in Legacy BIOS compatibility mode.
3. Save your setting.
4. Reboot the server.

Secure Boot

Secure Boot is a server security feature that is implemented in the BIOS and does not require special hardware. Secure Boot ensures that each component launched during the boot process is digitally signed and that the signature is validated against a set of trusted certificates embedded in the UEFI BIOS. Secure Boot validates the software identity of the following components in the boot process:

- UEFI drivers loaded from PCIe cards
- UEFI drivers loaded from mass storage devices
- Preboot UEFI Shell applications
- OS UEFI boot loaders

When Secure Boot is enabled:

- Firmware components and operating systems with boot loaders must have an appropriate digital signature to execute during the boot process.
- Operating systems must support Secure Boot and have an EFI boot loader signed with one of the authorized keys to boot. For more information about supported operating systems, see <https://www.hpe.com/servers/ossupport>.

You can customize the certificates embedded in the UEFI BIOS by adding or removing your own certificates, either from a management console directly attached to the server, or by remotely connecting to the server using the iLO Remote Console.

You can configure Secure Boot:

- Using the System Utilities options described in the following sections.
- Using the iLO RESTful API to clear and restore certificates. For more information, see the Hewlett Packard Enterprise website (<https://www.hpe.com/info/redfish>).
- Using the `secboot` command in the Embedded UEFI Shell to display Secure Boot databases, keys, and security reports.

Launching the Embedded UEFI Shell

Use the Embedded UEFI Shell option to launch the Embedded UEFI Shell. The Embedded UEFI Shell is a preboot command-line environment for scripting and running UEFI applications, including UEFI boot loaders. The Shell also provides CLI-based commands you can use to obtain system information, and to configure and update the system BIOS.

Prerequisites

- Embedded UEFI Shell is set to Enabled.

Procedure

1. From the System Utilities screen, select Embedded Applications > Embedded UEFI Shell.

The Embedded UEFI Shell screen appears.

2. Press any key to acknowledge that you are physically present.

This step ensures that certain features, such as disabling Secure Boot or managing the Secure Boot certificates using third-party UEFI tools, are not restricted.

3. If an administrator password is set, enter it at the prompt and press Enter.

The `Shell>` prompt appears.

4. Enter the commands required to complete your task.

5. Enter the `exit` command to exit the Shell.

iLO Service Port

The Service Port is a USB port with the label **iLO** on supported servers and compute modules.

To find out if your server or compute module supports this feature, see the server specifications document at the following website: <https://www.hpe.com/info/qs>.

When you have physical access to a server, you can use the Service Port to do the following:

- Download the Active Health System Log to a supported USB flash drive.

When you use this feature, the connected USB flash drive is not accessible by the host operating system.

- Connect a client (such as a laptop) with a supported USB to Ethernet adapter to access the following:

- iLO web interface
- Remote console
- iLO RESTful API
- CLI

Hewlett Packard Enterprise recommends the HPE USB to Ethernet Adapter (part number Q7Y55A).

Some servers, such as the XL170r, require an adapter to connect a USB to Ethernet adapter to the iLO Service Port.

Hewlett Packard Enterprise recommends the HPE Micro USB to USB Adapter (part number 789904-B21).

When you use the iLO Service Port:

- Actions are logged in the iLO event log.
- The server UID flashes to indicate the Service Port status.

You can also retrieve the Service Port status by using a REST client and the iLO RESTful API.

- You cannot use the Service Port to boot any device within the server, or the server itself.
- You cannot access the server by connecting to the Service Port.
- You cannot access the connected device from the server.

For more information about the iLO Service Port, see the iLO user guide at the following website: <https://www.hpe.com/support/ilo-docs>.



For more information, see the [Anywhere Access to HPE ProLiant Gen10 Servers](#) video.

Intelligent Provisioning

Intelligent Provisioning is a single-server deployment tool embedded in ProLiant servers and HPE Synergy compute modules. Intelligent Provisioning simplifies server setup, providing a reliable and consistent way to deploy servers.

Intelligent Provisioning prepares the system for installing original, licensed vendor media and Hewlett Packard Enterprise-branded versions of OS software. Intelligent Provisioning also prepares the system to integrate optimized server support software from the Service Pack for ProLiant (SPP). SPP is a comprehensive systems software and firmware solution for ProLiant servers, server blades, their enclosures, and HPE Synergy compute modules. These components are preloaded with a basic set of firmware and OS components that are installed along with Intelligent Provisioning.

i IMPORTANT:

HPE ProLiant XL servers do not support operating system installation with Intelligent Provisioning, but they do support the maintenance features. For more information, see "Performing Maintenance" in the Intelligent Provisioning user guide and online help.

After the server is running, you can update the firmware to install additional components. You can also update any components that have been outdated since the server was manufactured.

To access Intelligent Provisioning:

- Press F10 from the POST screen and enter either Intelligent Provisioning or HPE Rapid Setup Software.
- From the iLO web interface using Lifecycle Management. Lifecycle Management allows you to access Intelligent Provisioning without rebooting your server.

HPE Insight Remote Support

Hewlett Packard Enterprise strongly recommends that you register your device for remote support to enable enhanced delivery of your Hewlett Packard Enterprise warranty, HPE support services, or Hewlett Packard Enterprise contractual support agreement. Insight Remote Support supplements your monitoring continuously to ensure maximum system availability by providing intelligent event diagnosis, and automatic, secure submission of hardware event notifications to Hewlett Packard Enterprise, which will initiate a fast and accurate resolution, based on your product's service level. Notifications can be sent to your authorized Hewlett Packard Enterprise Channel Partner for onsite service, if configured and available in your country.

For more information, see *Insight Remote Support and Insight Online Setup Guide for ProLiant Servers and BladeSystem c-Class Enclosures* on the [Hewlett Packard Enterprise website](#). Insight Remote Support is available as part of Hewlett Packard Enterprise Warranty, HPE support services, or Hewlett Packard Enterprise contractual support agreement.

HPE InfoSight for servers

The HPE InfoSight portal is a secure web interface hosted by HPE that allows you to monitor supported devices through a graphical interface.

HPE InfoSight for servers:

- Combines the machine learning and predictive analytics of HPE InfoSight with the health and performance monitoring of Active Health System (AHS) and HPE iLO to optimize performance and predict and prevent problems
- Provides automatic collection and analysis of the sensor and telemetry data from AHS to derive insights from the behaviors of the install base to provide recommendations to resolve problems and improve performance

For more information on getting started and using HPE InfoSight for servers, go to: <https://www.hpe.com/info/infosight-servers-docs>.

USB support

Hewlett Packard Enterprise Gen10 and Gen10 Plus servers support all USB operating speeds depending on the device that is connected to the server.

External USB functionality

Hewlett Packard Enterprise provides external USB support to enable local connection of USB devices for server administration, configuration, and diagnostic procedures.

For additional security, external USB functionality can be disabled through USB options in UEFI System Utilities.

Smart Storage Administrator

SSA is the main tool for configuring arrays on these controllers. It exists in three interface formats: the SSA GUI, the SSA CLI, and SSA Scripting. All formats provide support for configuration tasks. Some of the advanced tasks are available in only one format.

The diagnostic features in SSA are also available in the standalone software Smart Storage Administrator Diagnostics Utility CLI.

- **Accessing SSA in the offline environment:** Using one of multiple methods, you can run SSA before launching the host operating system. In offline mode, users can configure or maintain detected and supported HPE ProLiant devices, such as optional controllers and integrated controllers. Some SSA features are only available in the offline environment, such as setting the boot controller or performing split-mirror operations.
- **Accessing SSA in the online environment:** This method requires an administrator to download the SSA executables and install them. You can run SSA online after launching the host operating system.

Component identification

Front panel components

SFF front panel components

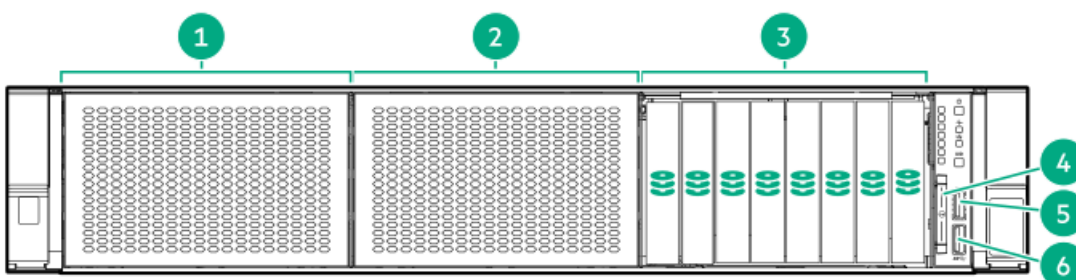

Item	Description
1	Box 1 (optional drives or universal media bay)
2	Box 2 (optional drives)
3	Box 3 Drives 1-8
4	Serial number/iLO information pull tab or optional Systems Insight Display
5	iLO Service port
6	USB 3.0 port

Universal media bay components

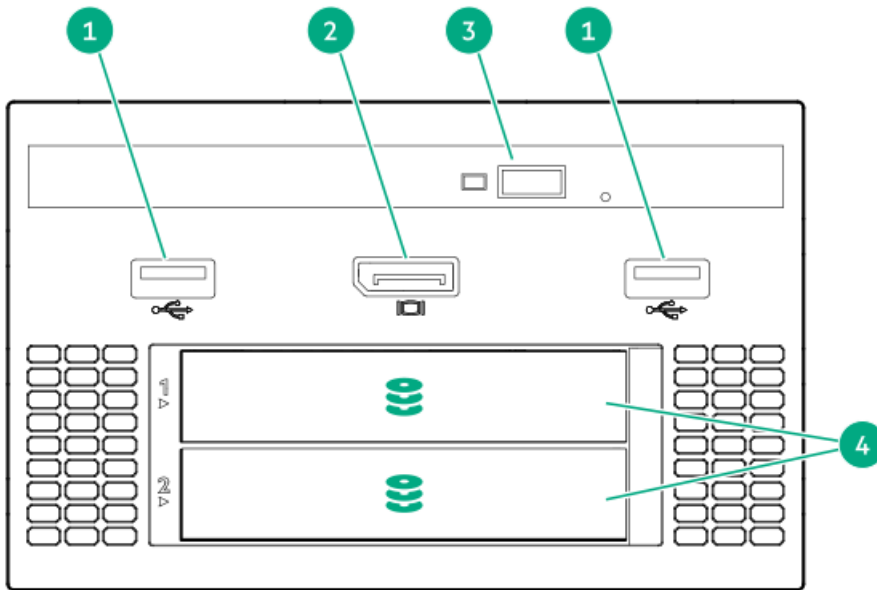

Item	Description
1	USB 2.0 port
2	Video display port
3	Optical disc drive (optional)
4	Drives (optional)

12-drive LFF front panel components



Item	Description
1	Drive bays or Optical/video/USB (optional)
2	Drive bays (optional)
3	Drive bays

8-drive LFF model front panel components



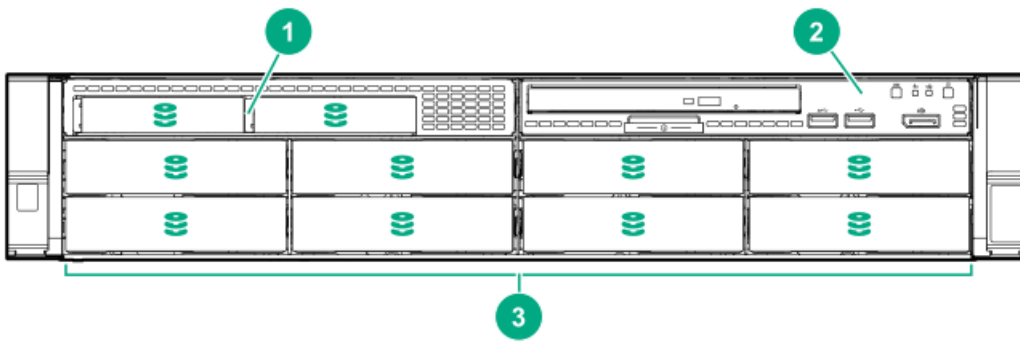

Item Description

1	2 SFF module (optional)
2	LFF power switch module
3	Drive bays

LFF power switch module components

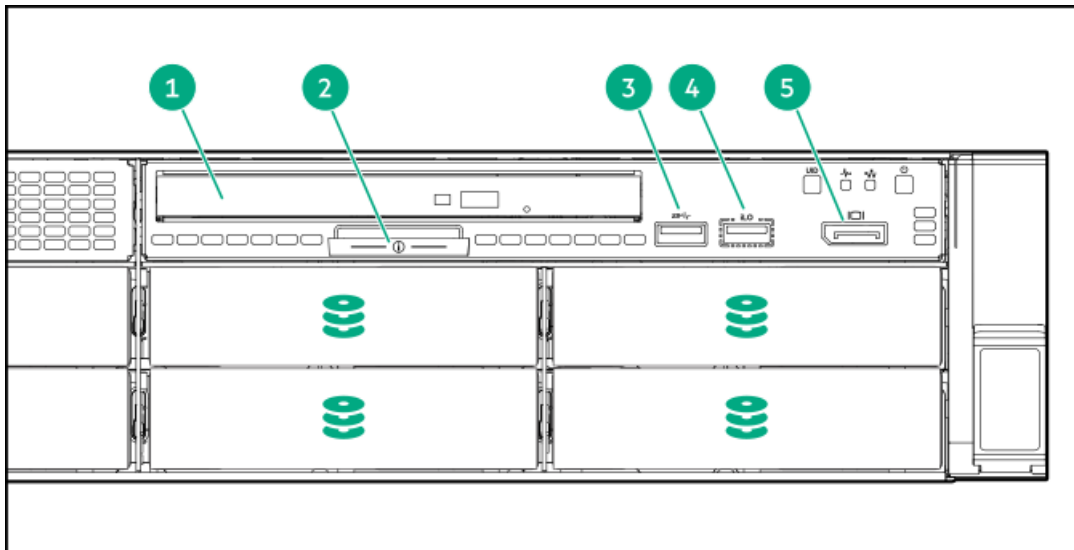

Item Description

1	Optical disk drive
2	Serial number/iLO information pull tab
3	USB 3.0 port
4	iLO Service port
5	Display port

Front panel LEDs and buttons

SFF front panel LEDs and buttons



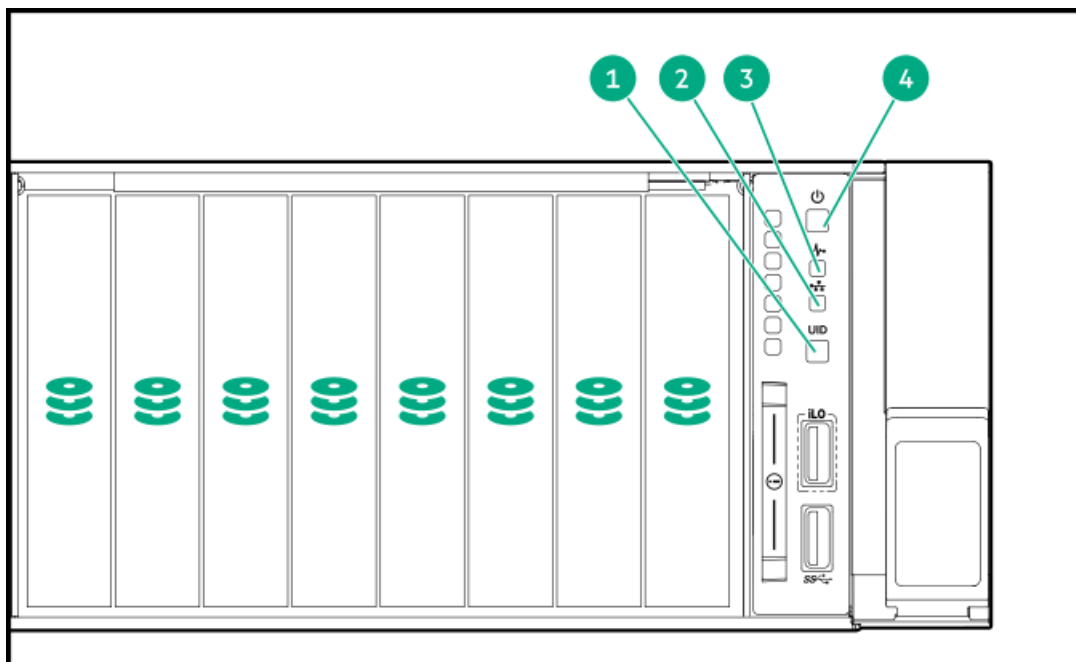

Item	Description	Status
1	UID button/LED ¹	<ul style="list-style-type: none"> • Solid blue = Activated • Flashing blue: <ul style="list-style-type: none"> ◦ 1 Hz/cycle per sec = Remote management or firmware upgrade in progress ◦ 4 Hz/cycle per sec = iLO manual reboot sequence initiated ◦ 8 Hz/cycle per sec = iLO manual reboot sequence in progress ◦ Off = Deactivated
2	NIC status LED ¹	<ul style="list-style-type: none"> • Solid green = Link to network • Flashing green (1 Hz/cycle per sec) = Network active • Off = No network activity
3	Health LED ¹	<ul style="list-style-type: none"> • Solid green = Normal • Flashing green (1 Hz/cycle per sec) = iLO is rebooting • Flashing amber = System degraded • Flashing red (1 Hz/cycle per sec) = System critical ²
4	Power On/Standby button and system power LED ¹	<ul style="list-style-type: none"> • Solid green = System on • Flashing green (1 Hz/cycle per sec) = Performing power on sequence • Solid amber = System in standby • Off = No power present ³

¹ When all four LEDs described in this table flash simultaneously, a power fault has occurred.

² If the health LED indicates a degraded or critical state, review the system IML or use iLO to review the system health status.

³ Facility power is not present, the power cord is not attached, no power supplies are installed, power supply failure has occurred, or

the power button cable is disconnected.

12 LFF front panel LEDs and buttons

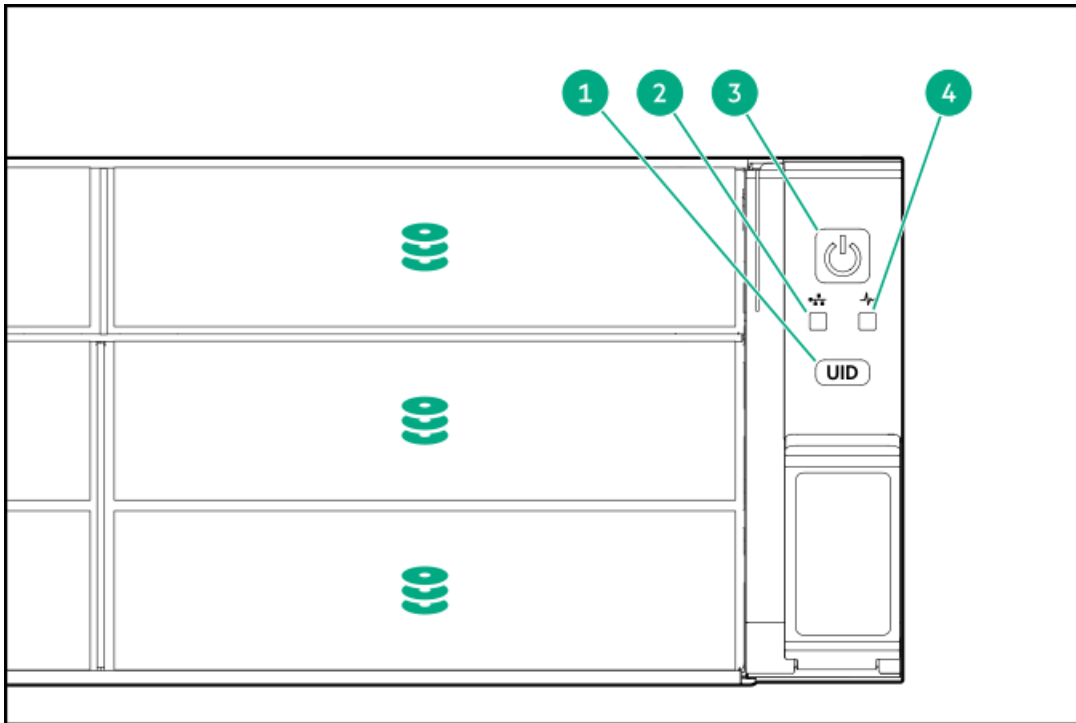

Item	Description	Status
1	UID button/LED ¹	<ul style="list-style-type: none">• Solid blue = Activated• Flashing blue:<ul style="list-style-type: none">◦ 1 Hz/cycle per sec = Remote management or firmware upgrade in progress◦ 4 Hz/cycle per sec = iLO manual reboot sequence initiated◦ 8 Hz/cycle per sec = iLO manual reboot sequence in progress• Off = Deactivated
2	NIC status LED ¹	<ul style="list-style-type: none">• Solid green = Link to network• Flashing green (1 Hz/cycle per sec) = Network active• Off = No network activity
3	Power On/Standby button and system power LED ¹	<ul style="list-style-type: none">• Solid green = System on• Flashing green (1 Hz/cycle per sec) = Performing power on sequence• Solid amber = System in standby• Off = No power present ²

Item	Description	Status
4	Health LED ¹	<ul style="list-style-type: none"> • Solid green = Normal • Flashing green (1 Hz/cycle per sec) = iLO is rebooting • Flashing amber = System degraded • Flashing red (1 Hz/cycle per sec) = System critical ³

¹ When all four LEDs described in this table flash simultaneously, a power fault has occurred.

² Facility power is not present, the power cord is not attached, no power supplies are installed, power supply failure has occurred, or the power button cable is disconnected.

³ If the health LED indicates a degraded or critical state, review the system IML or use iLO to review the system health status.

LFF power switch module LEDs and buttons

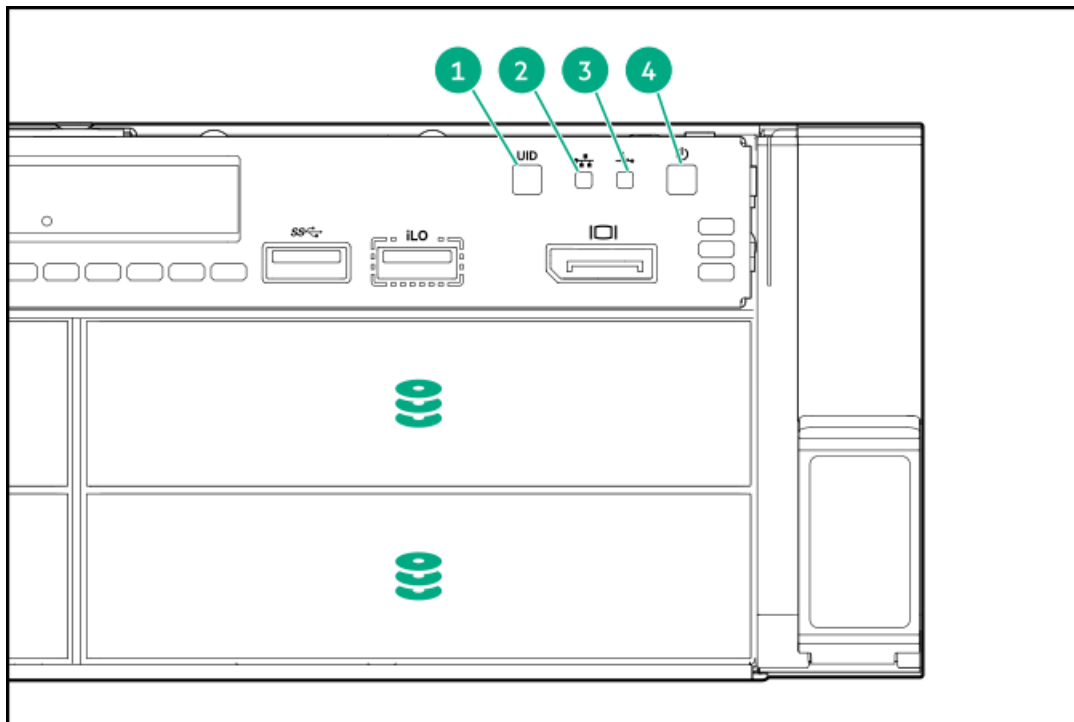

Item	Description	Status
1	UID button/LED ¹	<ul style="list-style-type: none"> • Solid blue = Activated • Flashing blue: <ul style="list-style-type: none"> ◦ 1 Hz/cycle per sec = Remote management or firmware upgrade in progress ◦ 4 Hz/cycle per sec = iLO manual reboot sequence initiated ◦ 8 Hz/cycle per sec = iLO manual reboot sequence in progress • Off = Deactivated

Item	Description	Status
2	NIC status LED ¹	<ul style="list-style-type: none"> • Solid green = Link to network • Flashing green (1 Hz/cycle per sec) = Network active • Off = No network activity
3	Health LED ¹	<ul style="list-style-type: none"> • Solid green = Normal • Flashing green (1 Hz/cycle per sec) = iLO is rebooting • Flashing amber = System degraded • Flashing red (1 Hz/cycle per sec) = System critical ²
4	Power On/Standby button and system power LED ¹	<ul style="list-style-type: none"> • Solid green = System on • Flashing green (1 Hz/cycle per sec) = Performing power on sequence • Solid amber = System in standby • Off = No power present ³

¹ When all four LEDs described in this table flash simultaneously, a power fault has occurred.

² If the health LED indicates a degraded or critical state, review the system IML or use iLO to review the system health status.

³ Facility power is not present, the power cord is not attached, no power supplies are installed, power supply failure has occurred, or the power button cable is disconnected.

UID button functionality

The UID button can be used to display the Server Health Summary when the server will not power on. For more information, see the latest HPE iLO 5 User Guide on the [Hewlett Packard Enterprise website](#).

Front panel LED power fault codes

The following table provides a list of power fault codes, and the subsystems that are affected. Not all power faults are used by all servers.

Subsystem	LED behavior
System board	1 flash
Processor	2 flashes
Memory	3 flashes
Riser board PCIe slots	4 flashes
OCP adapter	5 flashes
Storage controller	6 flashes
System board PCIe slots	7 flashes
Power backplane	8 flashes
Storage backplane	9 flashes

Subsystem	LED behavior
Power supply	10 flashes
PCIe expansion cards installed in riser board	11 flashes
Chassis	12 flashes
GPU card	13 flashes

Systems Insight Display LEDs

The Systems Insight Display LEDs represent the system board layout. The display enables diagnosis with the access panel installed.

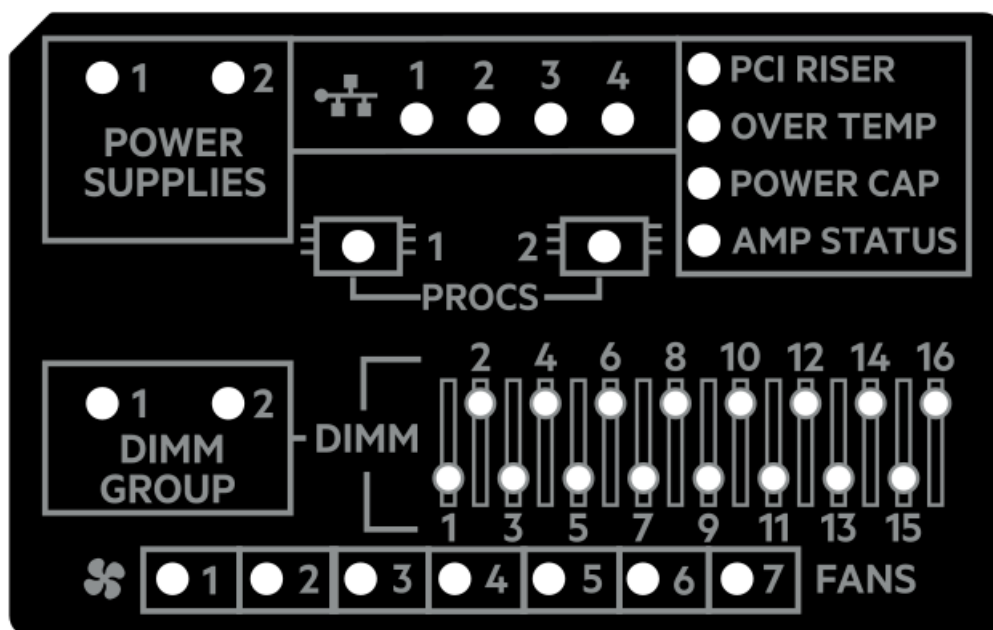

Description	Status
Processor LEDs	Off = Normal Amber = Failed processor
DIMM LEDs	Off = Normal Amber = Failed DIMM or configuration issue
Fan LEDs	Off = Normal Amber = Failed fan or missing fan
NIC LEDs ¹	Off = No link to network Solid green = Network link Flashing green = Network link with activity If power is off, the front panel LED is not active. For status, see Rear panel LEDs .
Power supply LEDs	Off = Normal Solid amber = Power subsystem degraded, power supply failure, or input power lost.

Description	Status
PCI riser LED	Off = Normal Amber = Incorrectly installed PCI riser cage
Over temp LED	Off = Normal Amber = High system temperature detected
Power cap LED	Off = System is in standby, or no cap is set. Solid green = Power cap applied
Amp Status LED	Off = AMP modes disabled Solid green = AMP mode enabled Solid amber = Failover Flashing amber = Invalid configuration

¹ Embedded NIC ports are not equipped on the server. NIC LEDs on the Systems Insight Display will flash based on the network adapter port activity. In the case of a dual-port adapters, only NIC LED 1 and 2 will illuminate to correspond with the activity of the respective network ports.

When the health LED on the front panel illuminates either amber or red, the server is experiencing a health event. For more information on the combination of these LEDs, see [Systems Insight Display combined LED descriptions](#).

Systems Insight Display combined LED descriptions

The combined illumination of the following LEDs indicates a system condition:

- Systems Insight Display LEDs
- System power LED
- Health LED

Systems Insight Display LED and color	Health LED	System power LED	Status
Processor (amber)	Red	Amber	One or more of the following conditions might exist: <ul style="list-style-type: none"> • Processor in socket X has failed. • Processor X is not installed in the socket. • Processor X is unsupported. • ROM detects a failed processor during POST.
Processor (amber)	Amber	Green	Processor in socket X is in a pre-failure condition.
DIMM (amber)	Red	Green	One or more DIMMs have failed.
DIMM (amber)	Amber	Green	DIMM in slot X is in a pre-failure condition.
Over temp (amber)	Amber	Green	The Health Driver has detected a cautionary temperature level.

Systems Insight Display LED and color	Health LED	System power LED	Status
Over temp (amber)	Red	Amber	The server has detected a hardware critical temperature level.
PCI riser (amber)	Red	Green	The PCI riser cage is not seated properly.
Fan (amber)	Amber	Green	One fan has failed or has been removed.
Fan (amber)	Red	Green	Two or more fans have failed or been removed.
Power supply (amber)	Red	Amber	One or more of the following conditions might exist: <ul style="list-style-type: none"> • Only one power supply is installed and that power supply is in standby. • Power supply fault. • System board fault.
Power supply (amber)	Amber	Green	One or more of the following conditions might exist: <ul style="list-style-type: none"> • Redundant power supply is installed and only one power supply is functional. • AC power cord is not plugged into redundant power supply. • Redundant power supply fault. • Power supply mismatch at POST or power supply mismatch through hot-plug addition.
Power cap (off)	—	Amber	Standby.
Power cap (green)	—	Flashing green	Waiting for power.
Power cap (green)	—	Green	Power is available.
Power cap (flashing amber)	—	Amber	Power is not available.

i IMPORTANT: If more than one DIMM slot LED is illuminated, further troubleshooting is required. Test each bank of DIMMs by removing all other DIMMs. Isolate the failed DIMM by replacing each DIMM in a bank with a known working DIMM.

Rear panel components

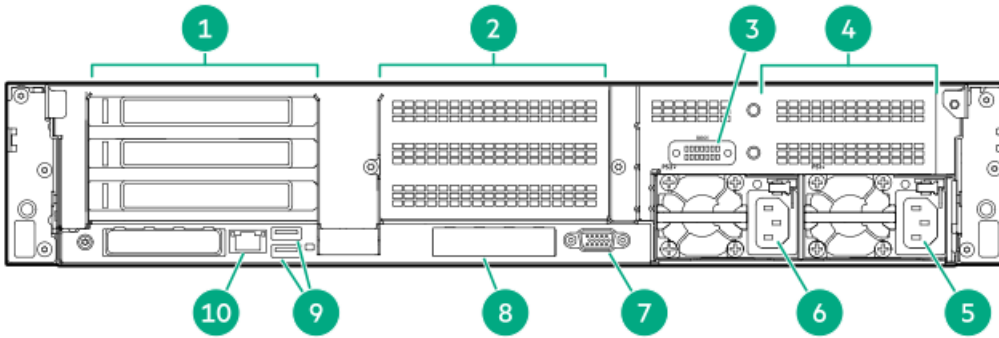

Item	Description
1	Primary riser slots 1–3 (optional drive cage)
2	Secondary riser slots 4–6 (optional drive cage)
3	Serial port (optional) ¹
4	Tertiary riser slots 7–8 (optional drive cage)
5	Power supply 1
6	Power supply 2
7	Video (VGA) port
8	OCP 3.0 adapter (optional)
9	USB 3.0 connectors
10	iLO Management Port

¹ When a secondary or tertiary riser cage is installed as shown, the serial port can be installed in the riser slot 8.

Rear panel LEDs

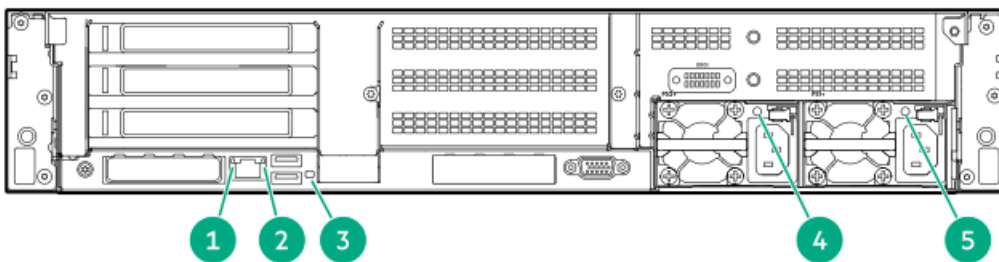

Item	Description	Status
1	Link LED	<ul style="list-style-type: none"> Off = No network link Green = Network link
2	Status LED	<ul style="list-style-type: none"> Off = No network activity Solid green = Link to network Flashing green = Network activity
3	UID LED	<ul style="list-style-type: none"> Off = Deactivated Solid blue = Activated Flashing blue = System is being managed remotely

Item	Description	Status
4-5	Power supply LED	<ul style="list-style-type: none"> Off = System is off or power supply has failed Solid green = Normal

System board components

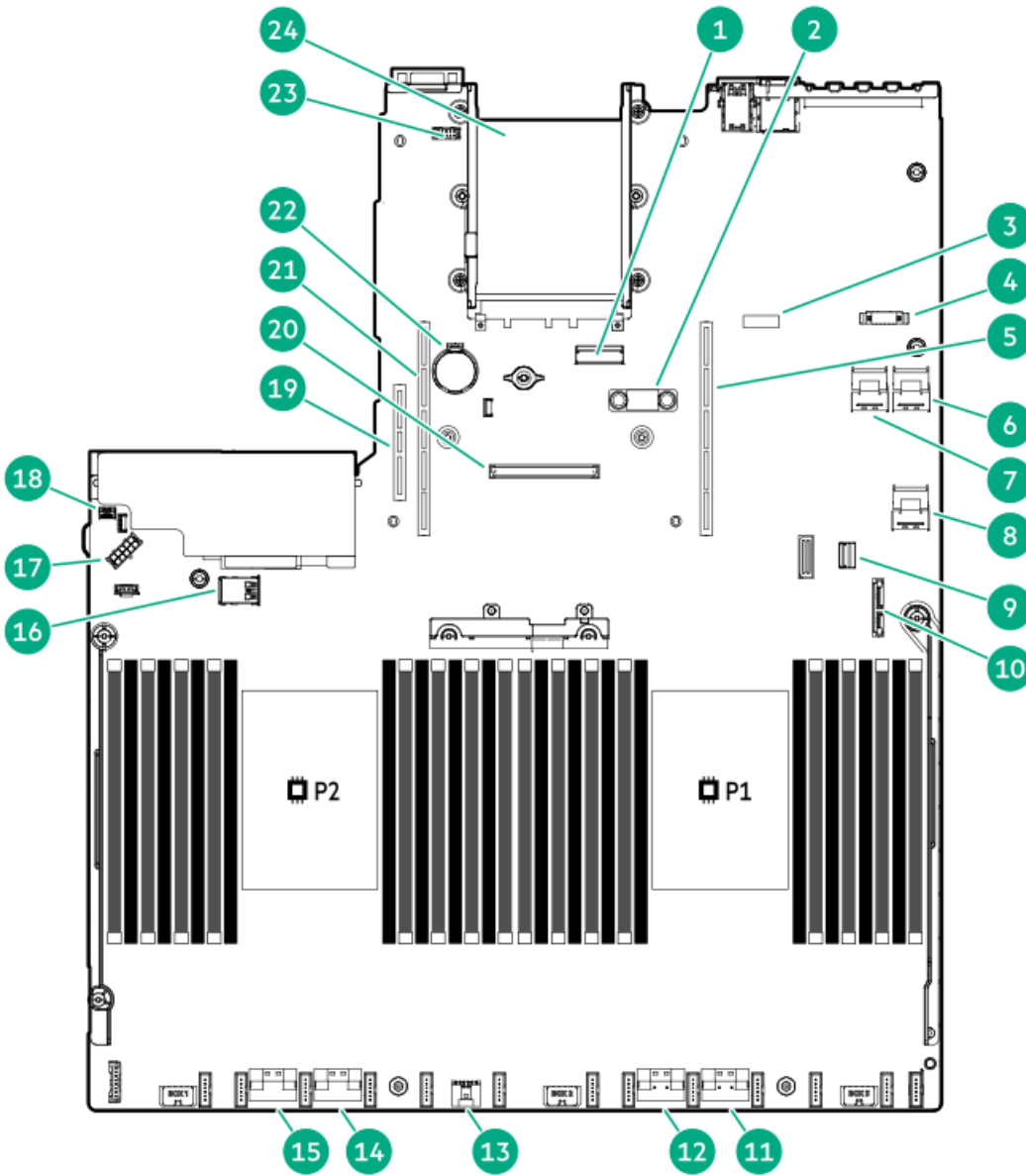

Item	Description
1	x8 Slimline connector
2	TPM connector
3	System maintenance switch
4	Front display port/USB 2.0 connector
5	Primary (processor 1) PCIe riser connector
6	x4 SATA port 2
7	x4 SATA port 1

Item	Description
8	x4 SATA port 3
9	Front power/USB 3.0 connector
10	SATA optical port 4
11	x8 NVMe port 2A
12	x8 NVMe port 1A
13	Energy pack connector
14	x8 NVMe port 2B
15	x8 NVMe port 1B
16	Dual internal USB 3.0 connector
17	Drive backplane power connector
18	Chassis Intrusion Detection connector
19	Tertiary (processor 2) PCIe riser connector
20	Type-a storage controller slot
21	Secondary (processor 2) PCIe riser connector
22	System battery
23	Serial port connector
24	OCP 3.0 adapter bay

Heatsink and socket components

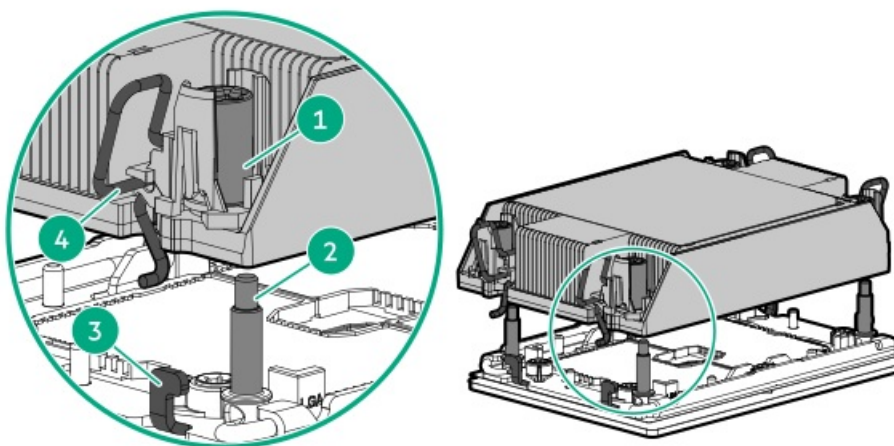

Item	Description
1	Heatsink nuts
2	Alignment screws
3	Latch tabs
4	Heatsink latches

DIMM label identification

To determine DIMM characteristics, see the label attached to the DIMM. The information in this section helps you to use the label to locate specific information about the DIMM.

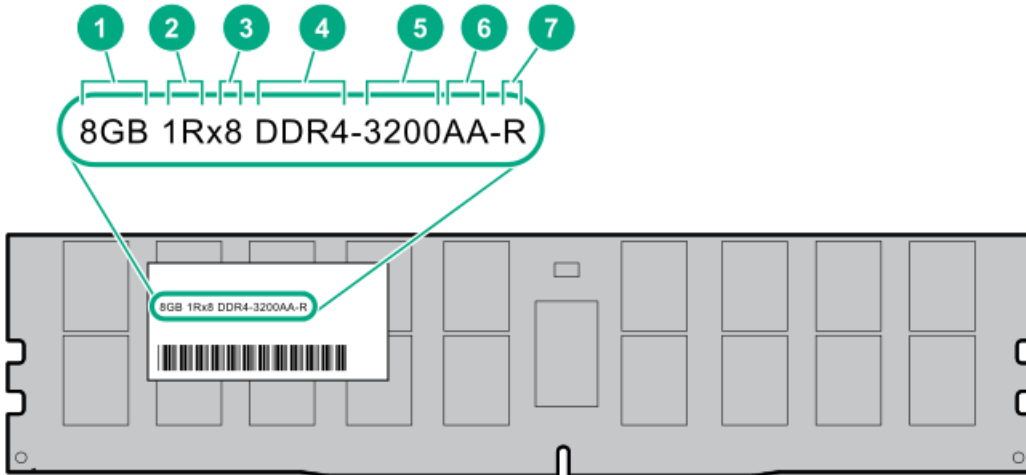

Item	Description	Example
1	Capacity	8 GB 16 GB 32 GB 64 GB 128 GB 256 GB
2	Rank	1R = Single rank 2R = Dual rank 4R = Quad rank 8R = Octal rank
3	Data width on DRAM	x4 = 4-bit x8 = 8-bit
4	Memory generation	PC4 = DDR4
5	Maximum memory speed	3200 MT/s
6	CAS latency	AA = CAS 22-22-22 AA = CAS 26-22-22 (for 3DS LRDIMM)
7	DIMM type	R = RDIMM (registered) L = LRDIMM (load reduced)

For more information about product features, specifications, options, configurations, and compatibility, see the HPE DDR4

Intel Optane persistent memory 200 series for HPE label identification

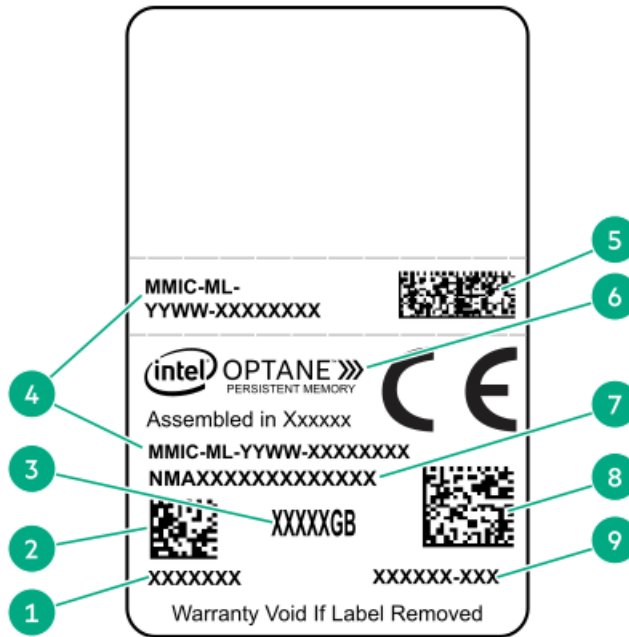

Item	Description	Example
1	Work Order Number	XXXXXXXX
2	Work Order Number Barcode	XXXXXXXX
3	Capacity	128 GB 256 GB 512 GB
4	Unique ID number	8089-A2-1802-1234567A
5	Serial Number and Part Number Barcode	S8089A218040000168APNMAXXXXXXXXXXXXXXX
6	Product Name	Intel® Optane™ persistent memory
7	Part Number	1234567A
8	Serial Number Barcode	8089-A2-1802-1234567A
9	PBA Number	XXXXXX-XXX

For more information about product features, specifications, options, configurations, and compatibility, see the product QuickSpecs on the Hewlett Packard Enterprise website (<https://www.hpe.com/support/persistentmemoryQS>).

DIMM slot locations

DIMM slots are numbered sequentially (1 through 16) for each processor.

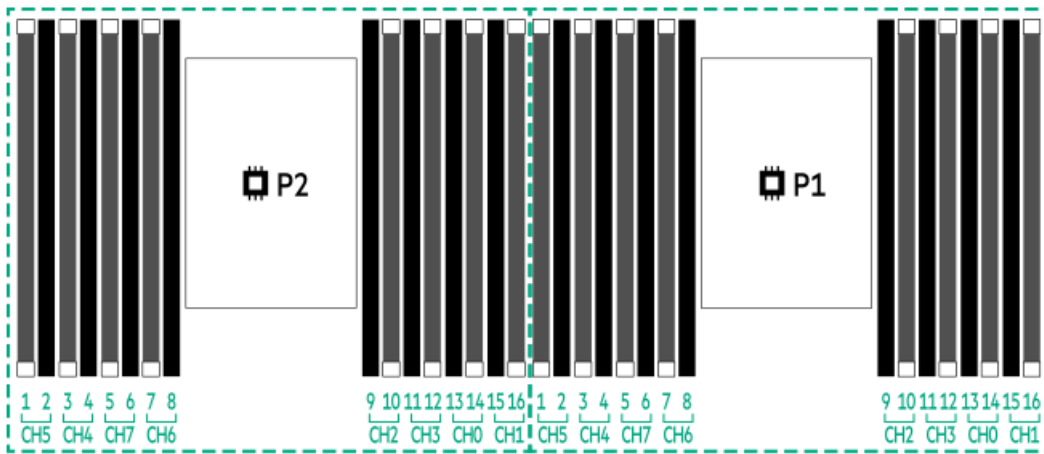

System maintenance switch descriptions

Position	Default	Function
S1 ¹	Off	Off = iLO security is enabled. On = iLO security is disabled.
S2	Off	Reserved
S3	Off	Reserved
S4	Off	Reserved
S5 ¹	Off	Off = Power-on password is enabled. On = Power-on password is disabled.
S6 ^{1, 2, 3}	Off	Off = No function On = Restore default manufacturing settings
S7	Off	Reserved
S8	—	Reserved
S9	—	Reserved
S10	—	Reserved
S11	—	Reserved
S12	—	Reserved

¹ To access the redundant ROM, set S1, S5, and S6 to On.

² When the system maintenance switch position 6 is set to the On position, the system is prepared to restore all configuration settings to their manufacturing defaults.

³ When the system maintenance switch position 6 is set to the On position and Secure Boot is enabled, some configurations cannot be restored.

For more information, see [Secure Boot](#).

Drive box identification

Front boxes

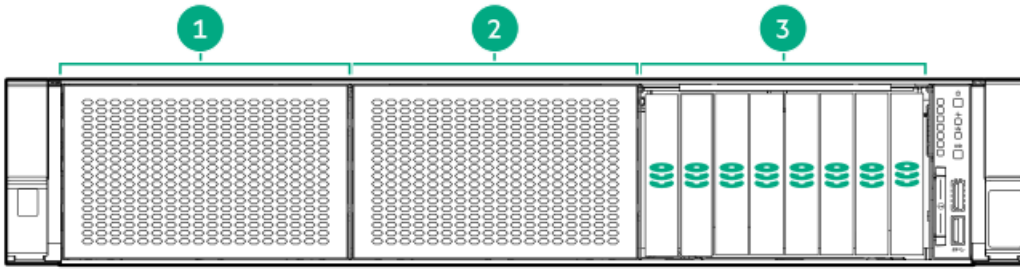

Item	Description
1	Box 1
2	Box 2
3	Box 3



Item	Description
1	Box 1
2	Box 2
3	Box 3

Rear boxes

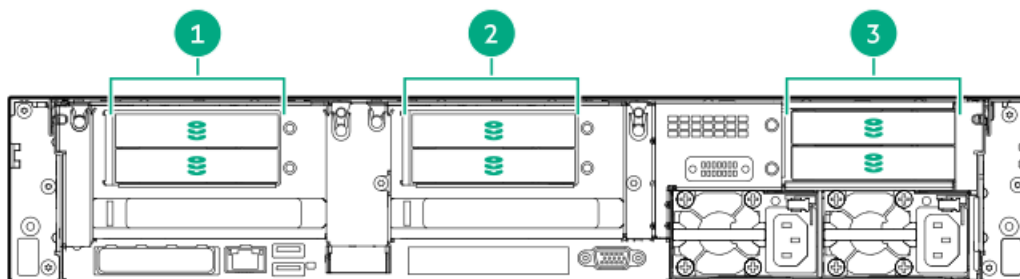

Item	Description
1	Box 4
2	Box 5
3	Box 6

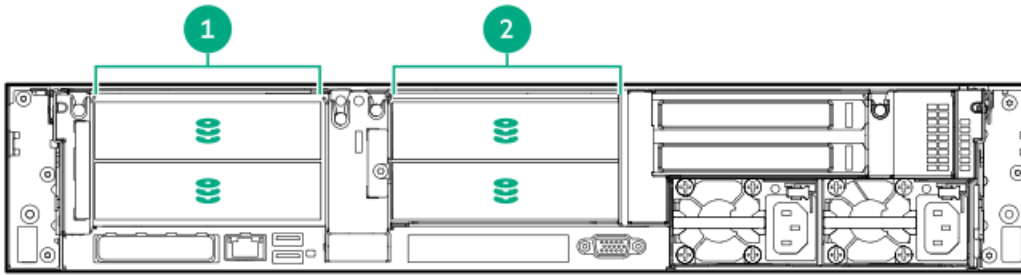

Item Description

1	Box 4
2	Box 5

Midplane box (LFF)

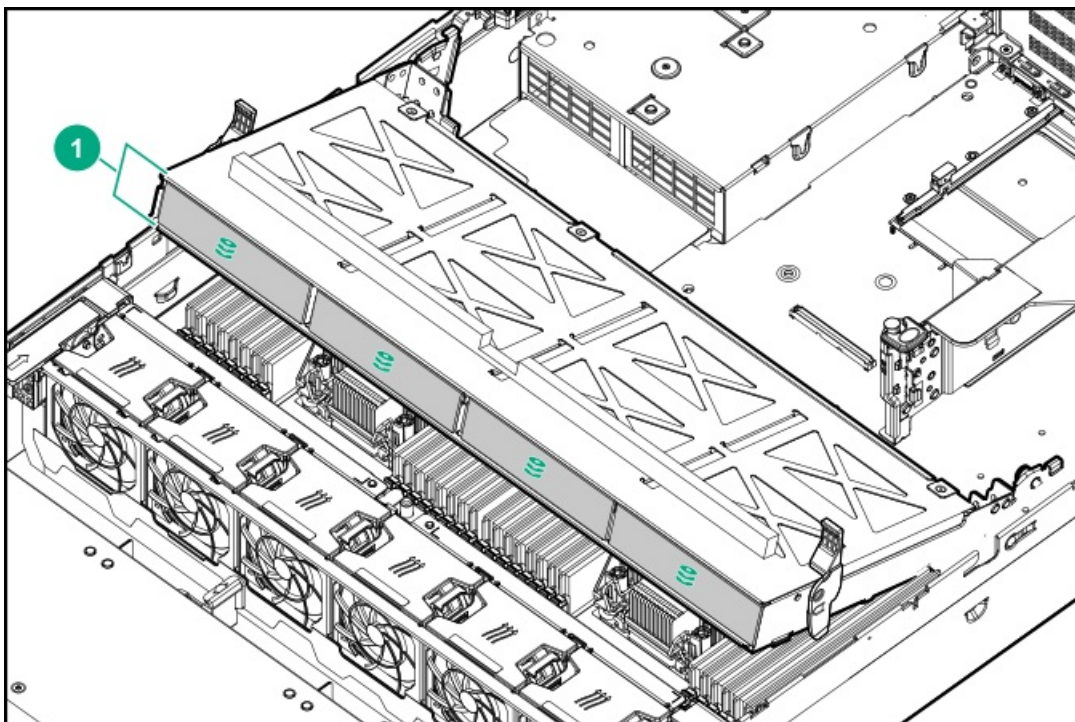

Item Description

1	Box 7
---	-------

Midplane box (SFF)



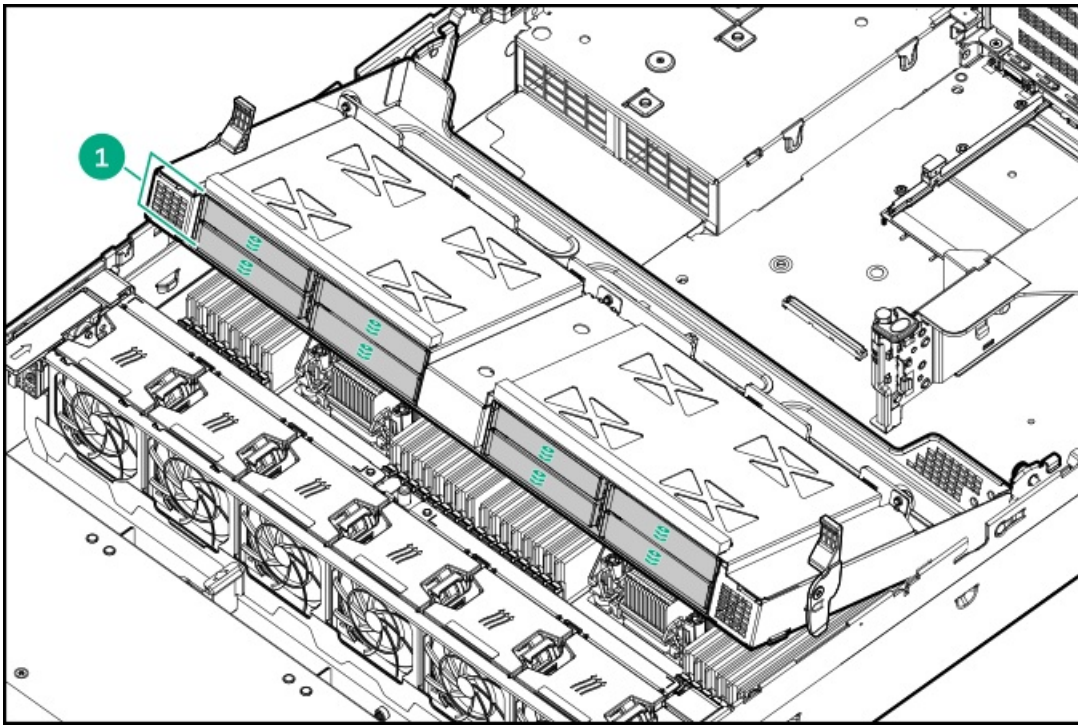

Item	Description
1	Box 7

Drive numbering

When the drive backplane is connected directly to a storage controller, then each drive box starts at 1. The following images are examples of common configurations.

24 SFF

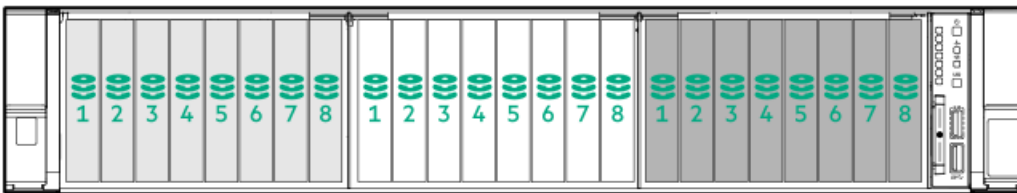

12 SFF





12 LFF



6 SFF rear panel

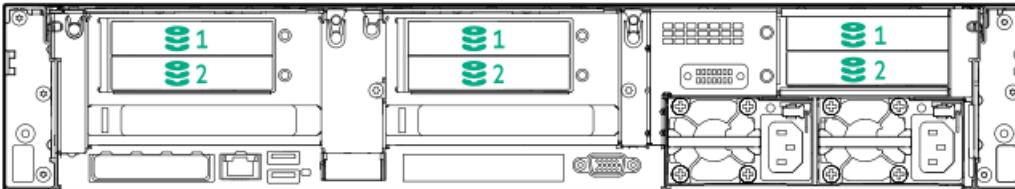

2x 2 LFF rear panel



Universal media bay

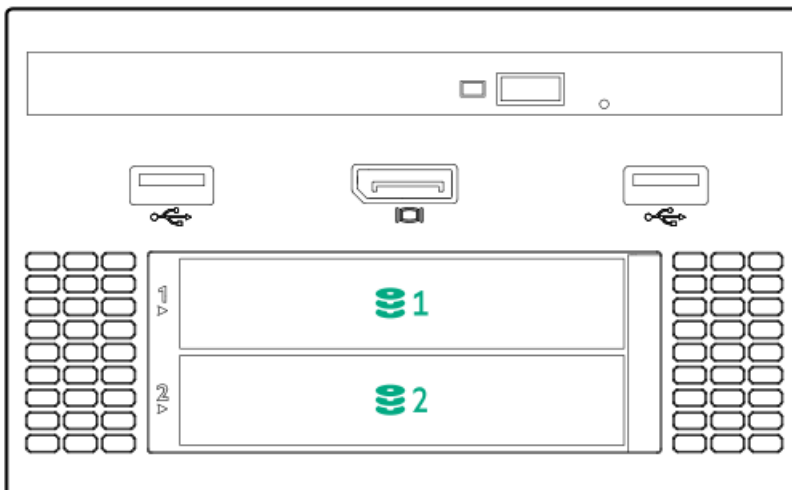

8 LFF + Universal media bay, optional 2 SFF, and optical drive

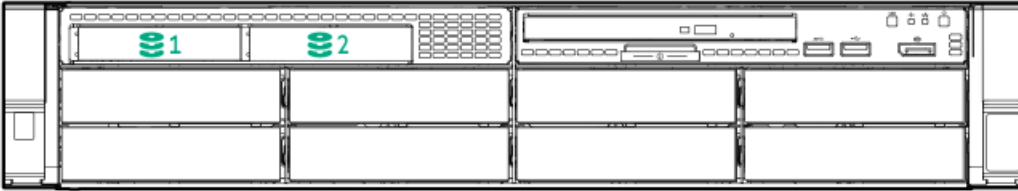

Midplane box LFF

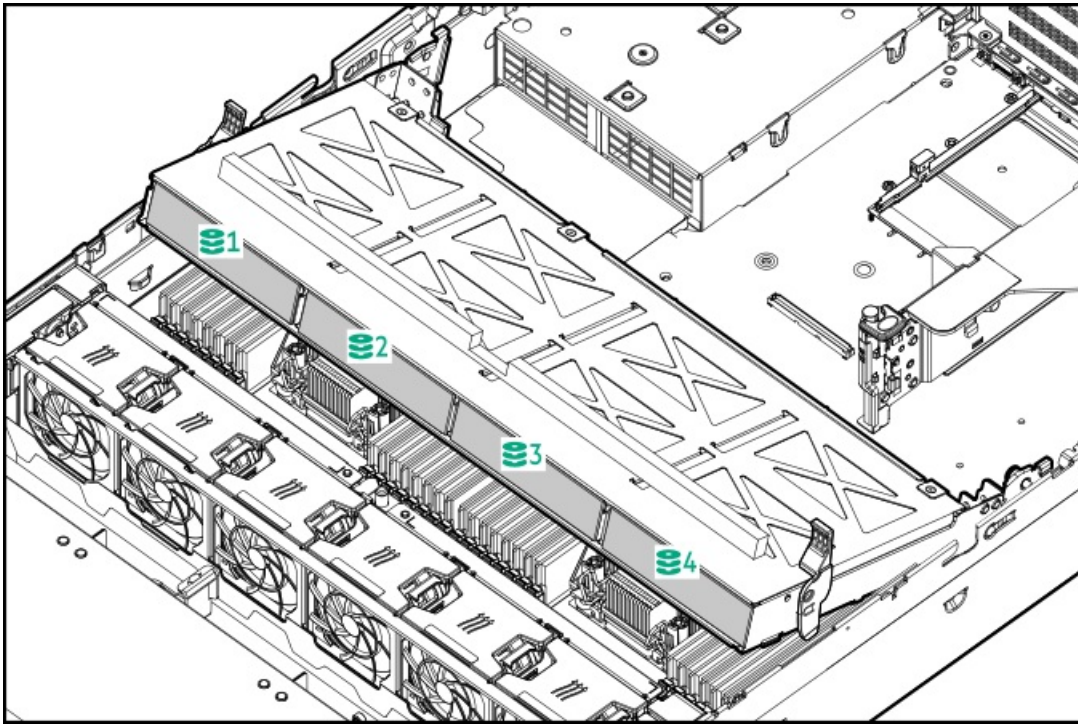

Midplane box SFF

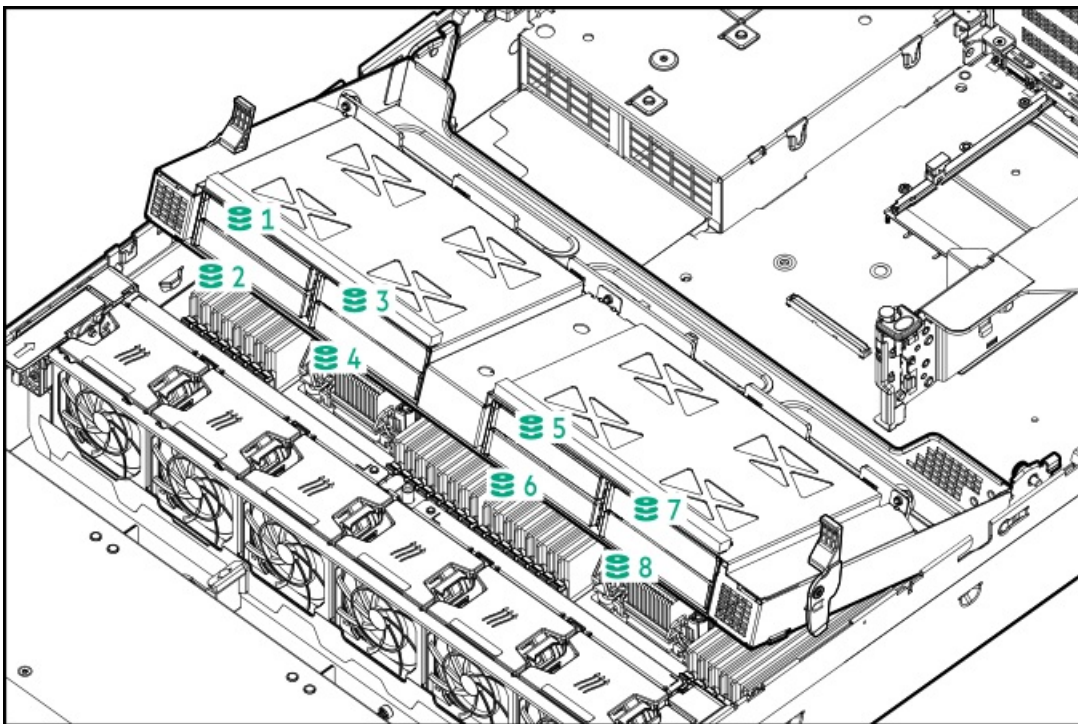

HPE Basic Drive LED definitions

LFF low-profile drive carrier

The LFF low-profile drive carrier supports hot-plug SAS and SATA drives.

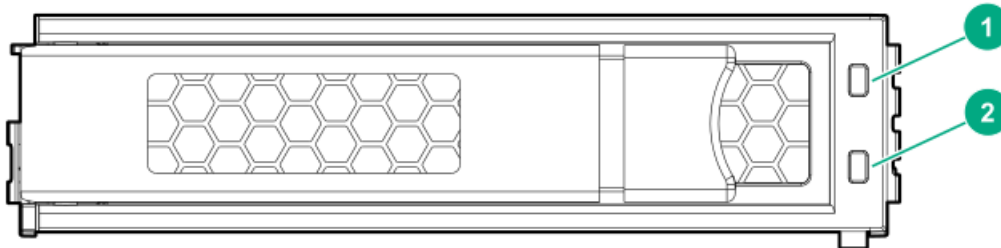

SFF basic drive carrier

The SFF basic drive carrier supports hot-plug SAS, SATA, and NVMe drives.

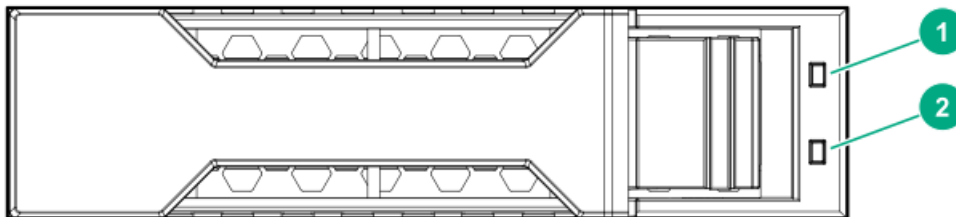

Item	LED	Status	Definition
1	Fault/Locate	Solid amber	This drive has failed, is unsupported, or is invalid.
		Solid blue	The drive is operating normally and being identified by a management application.
		Flashing amber/blue (1 flash per second)	The drive has failed, or a predictive failure alert has been received for this drive. The drive has also been identified by a management application.
		Flashing amber (1 flash per second)	A predictive failure alert has been received for this drive. Replace the drive as soon as possible.
2	Online/Activity	Solid green	The drive is online and has no activity.

Item	LED	Status	Definition
		Flashing green (1 flash per second)	The drive is doing one of the following: <ul style="list-style-type: none"> • Rebuilding or performing a RAID • Performing a stripe size migration • Performing a capacity expansion • Performing a logical drive extension • Erasing • Spare part activation
		Flashing green (4 flashes per second)	The drive is operation normally and has activity.
		Off	The drive is not configured by a RAID controller or is a spare drive.

Fan bay numbering

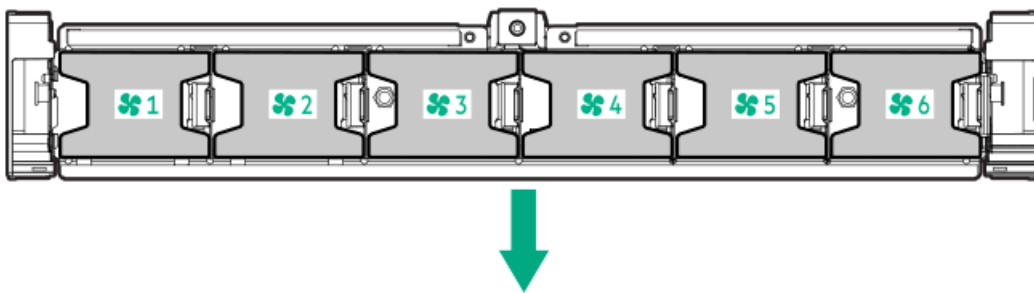

The arrow points to the front of the server.

DSC-25 2-port SFP28 card ports and LEDs

Ports

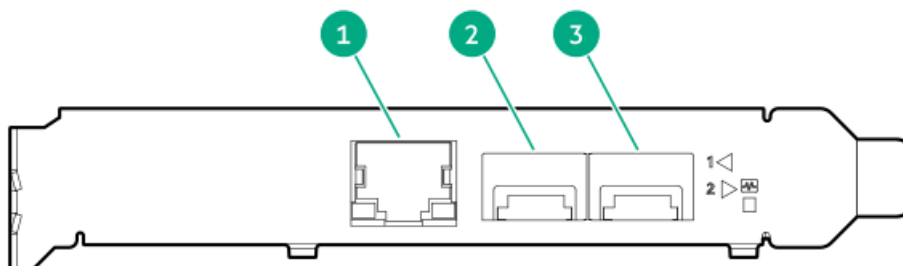

Table 1: Ports

Item	Port	Description
------	------	-------------

Item	Port	Description
1	Management port	1GbE RJ45
2	Network interface port	10/25G SFP+ based
3	Network interface port	10/25G SFP+ based

LEDs

The HPE for Pensando DSP DSC-25 2p SFP28 card is a dual-port, single-slot, half-height, half-length (HHHL) SFP28 network adapter. It has LEDs for Link (L) and Activity (A) for each port. A half-height bracket is shown in the following illustration with SFP28 ports and LEDs.

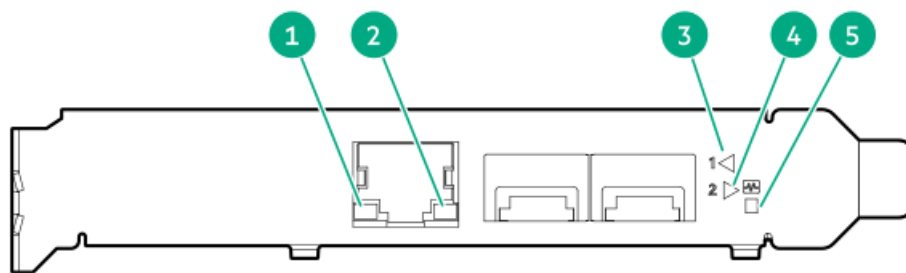
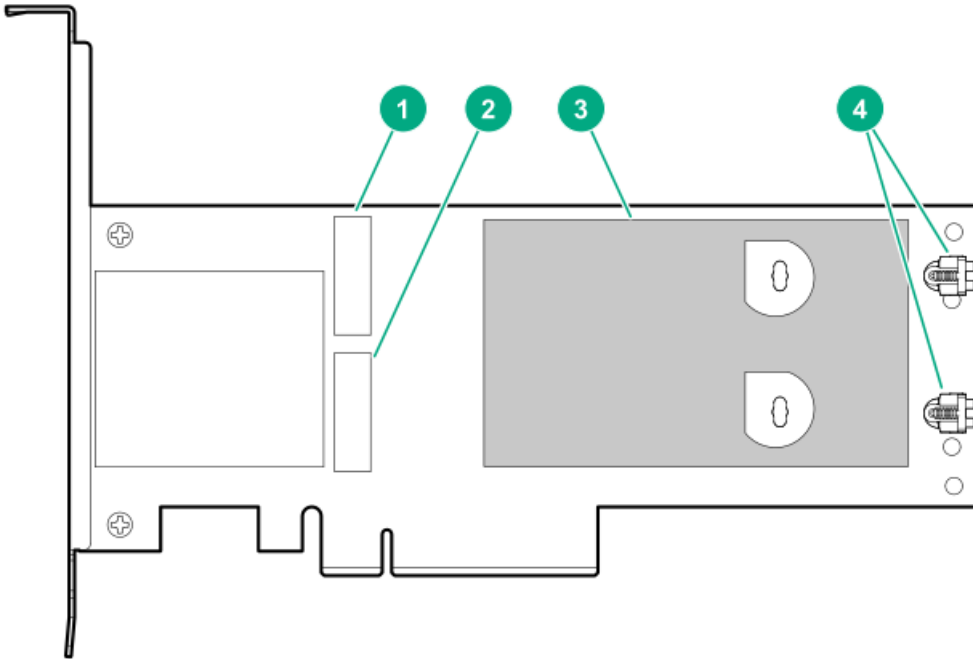

Table 2: LED indicators

Item	LED	Status	Description
1	Management Port Activity LED	Off	No activity
		Flashing	Passing traffic; flashing frequency indicates traffic intensity
2	Management Port Link LED	Off	A link has not been established
		Solid green	Valid Ethernet link
3	SFP Port 1 Link/Activity LED	Off	A link has not been established
		Solid green	Valid Ethernet link
		Flashing green	Passing traffic; flashing frequency indicates traffic intensity
		Solid amber	Link fault
4	SFP Port 2 Link/Activity LED	Off	A link has not been established
		Solid green	Valid Ethernet link
		Flashing green	Passing traffic; flashing frequency indicates traffic intensity
		Solid amber	Link fault
5	System status LED	Off	System is not powered
		Solid amber	Power is up, software has not booted yet
		Solid green	System is up and fully operational

HPE NS204i-p NVMe OS Boot Device components



Item	Description
1	Drive bay 1
2	Drive bay 2
3	Thermal interface pad with removable liner
4	M.2 drive retaining latches

HPE NS204i-p NVMe OS Boot Device LED definitions

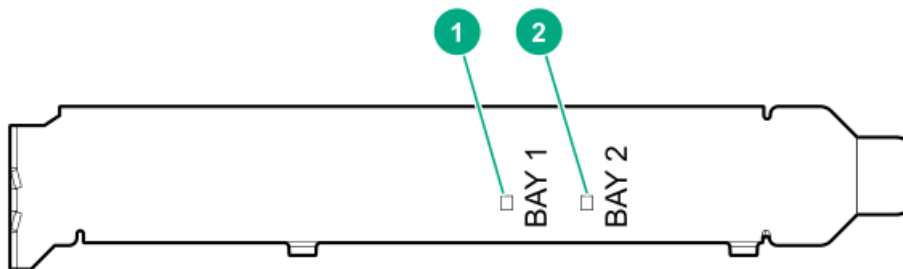

Item	Description	Fault LED status
1	Bay 1 LED	Off: Normal Flashing 1Hz: Drive predictive failure

Item	Description	Amber: Drive failure Fault LED status
2	Bay 2 LED	

Cabling

Cabling guidelines

The cable colors in the cabling diagrams used in this chapter are for illustration purposes only.

Observe the following guidelines when working with server cables.

Before connecting cables

- Note the port labels on the PCA components. Not all these components are used by all servers:
 - System board ports
 - Drive and power supply backplane ports
 - Expansion board ports (controllers, adapters, expanders, risers, and similar boards)
- Note the label near each cable connector. This label indicates the destination port for the cable connector.
- Some data cables are prebent. Do not unbend or manipulate the cables.
- To prevent mechanical damage or depositing oil that is present on your hands, and other contamination, do not touch the ends of the connectors.

When connecting cables

- Before connecting a cable to a port, lay the cable in place to verify the length of the cable.
- Use the internal cable management features to properly route and secure the cables.
- When routing cables, be sure that the cables are not in a position where they can be pinched or crimped.
- Avoid tight bend radii to prevent damaging the internal wires of a power cord or a server cable. Never bend power cords and server cables tight enough to cause a crease in the sheathing.
- Make sure that the excess length of cables is properly secured to avoid excess bends, interference issues, and airflow restriction.
- To prevent component damage and potential signal interference, make sure that all cables are in their appropriate routing position before installing a new component and before closing up the server after hardware installation/maintenance.

When disconnecting cables

- Grip the body of the cable connector. Do not pull on the cable itself because this action can damage the internal wires of the cable or the pins on the port.
- If a cable does not disconnect easily, check for any release latch that must be pressed to disconnect the cable.

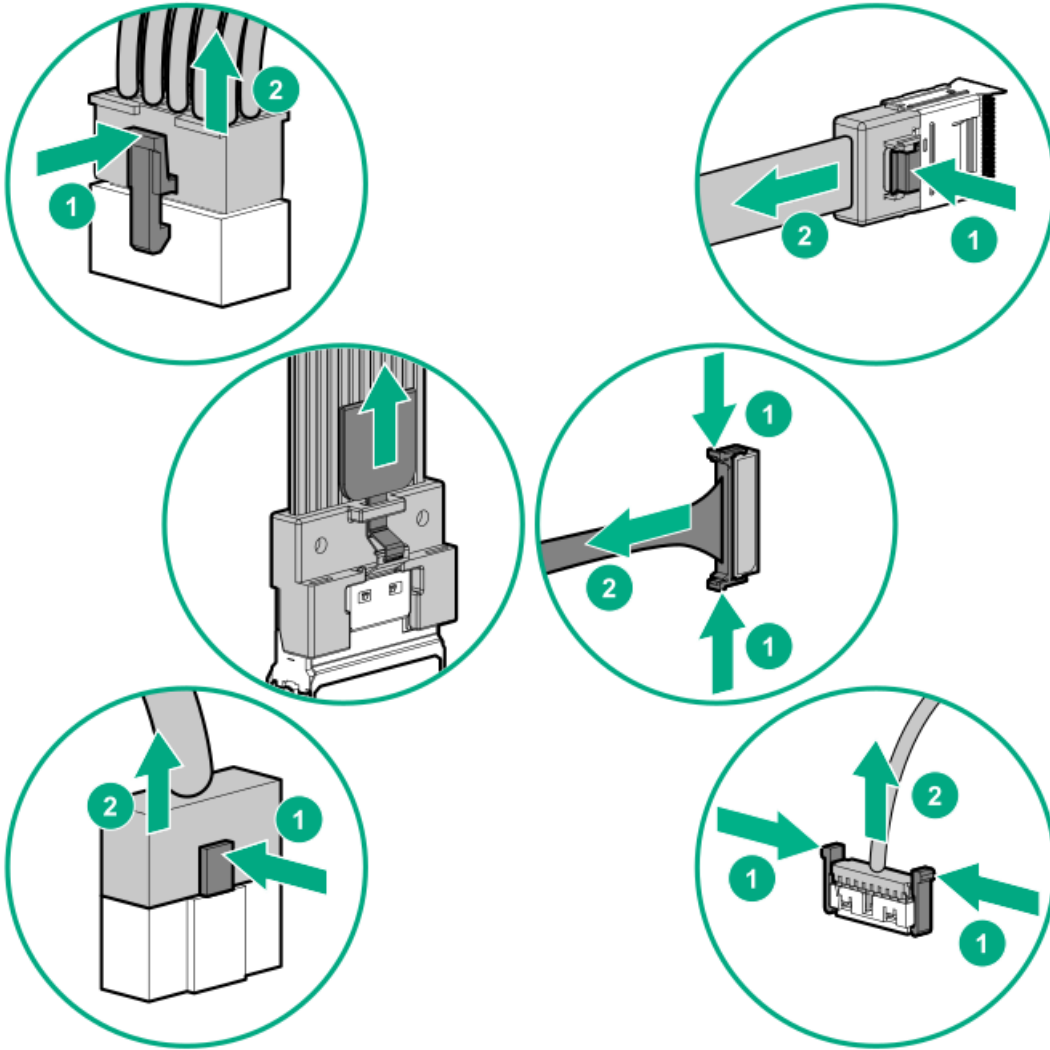

- Remove cables that are no longer being used. Retaining them inside the server can restrict airflow. If you intend to use the removed cables later, label and store them for future use.

Power cabling

Use the following tables to find cabling information and diagrams.

Table 36: Power cables

Cable description	Cable part number	From	To
PWR, 1x5 to 2x4, LFF, 240mm	P14341-001	Backplane	System board
PWR, 1x5 to 2x4, LFF, 400mm	P14342-001	Backplane	System board
PWR, 1x5 to 2x4 + x, LFF, 400mm	P14343-001	Backplane	System board
PWR, 2x3 to 2x3, SFF	P14345-001	Backplane	System board
PWR, 2x5 to 2x3 + 2x4 Midplane	P14346-001	Backplane	System board
PWR, 4LFF/8SFF	869825-001	Backplane	System board
I/O Wire to Board, FRONT	P14312-001	Backplane	System board

Cable routing: Front 8SFF power cabling

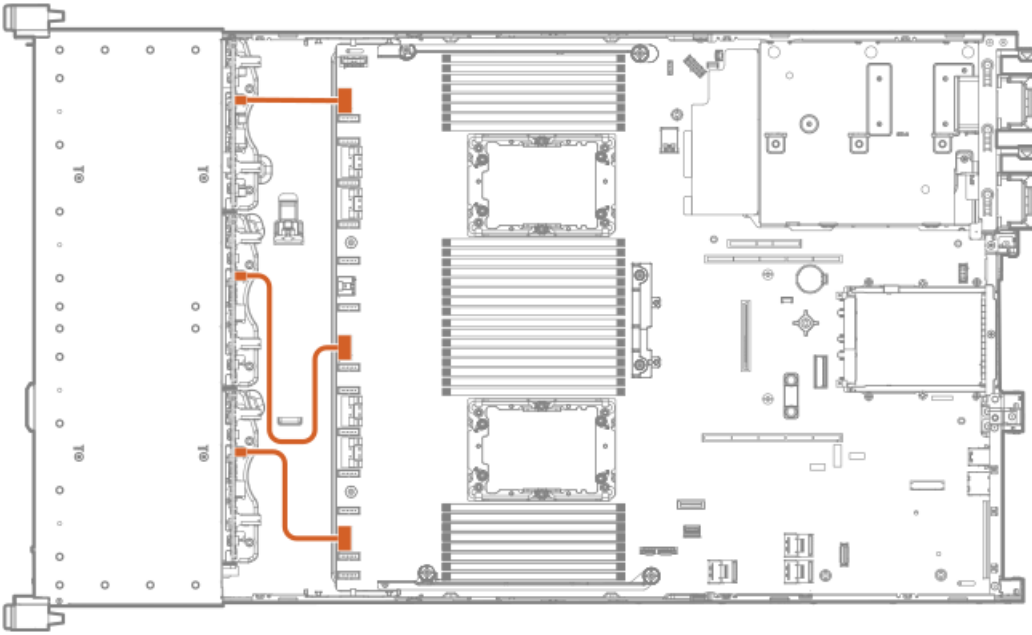

Cable routing: Front 12LFF power cabling

Box 1

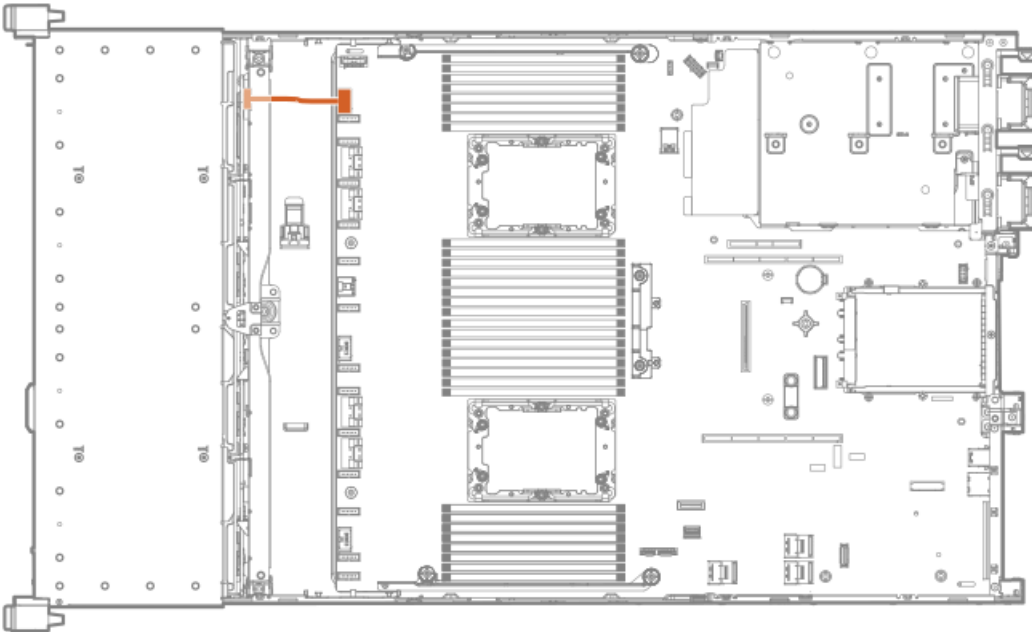

Box 2



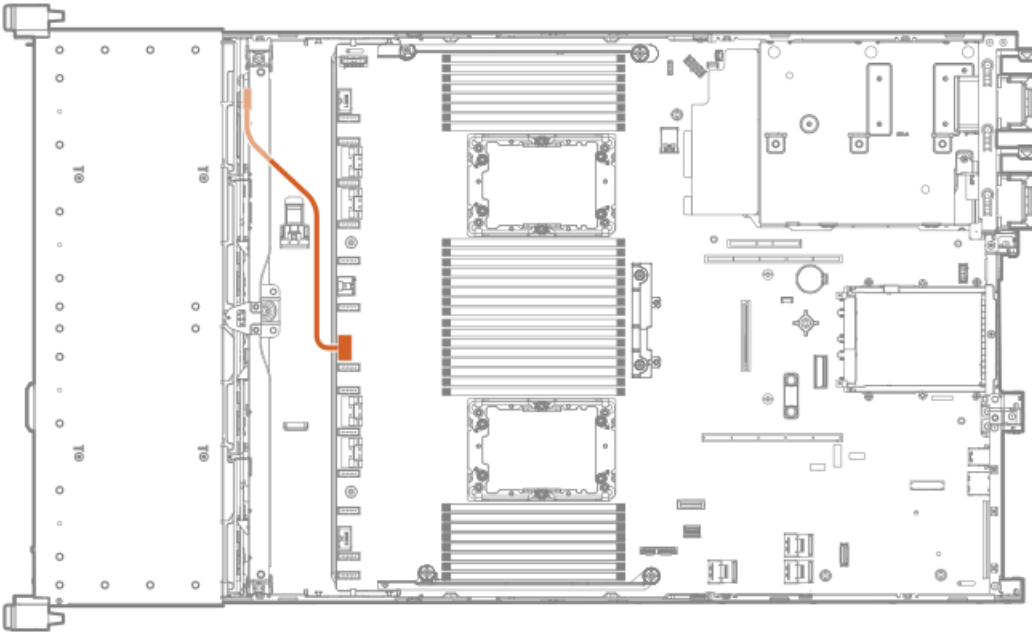

Box 3

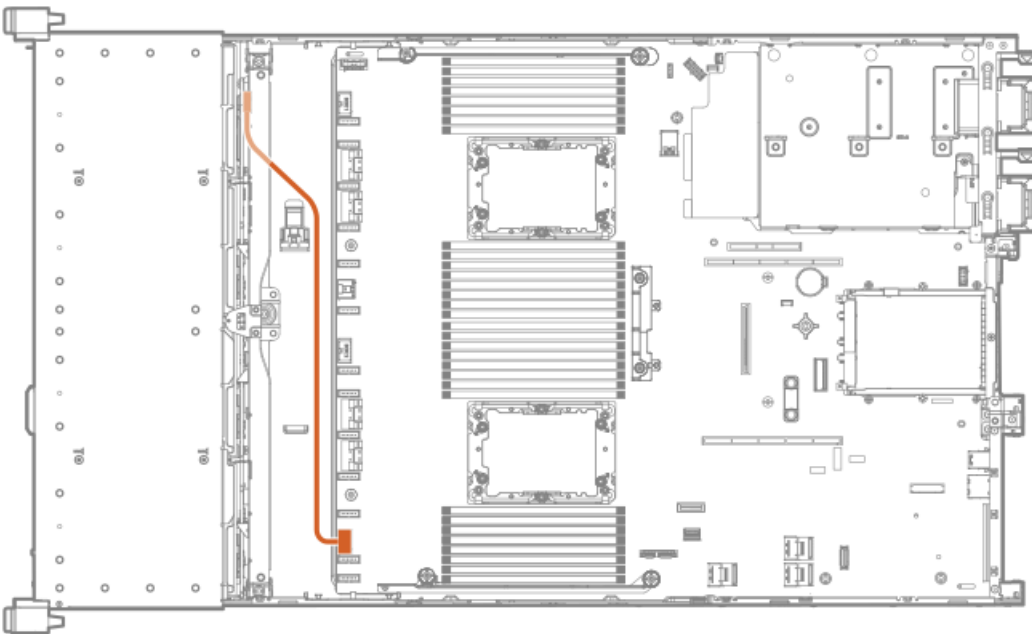

Cable routing: Midplane power cabling

8SFF midplane shown



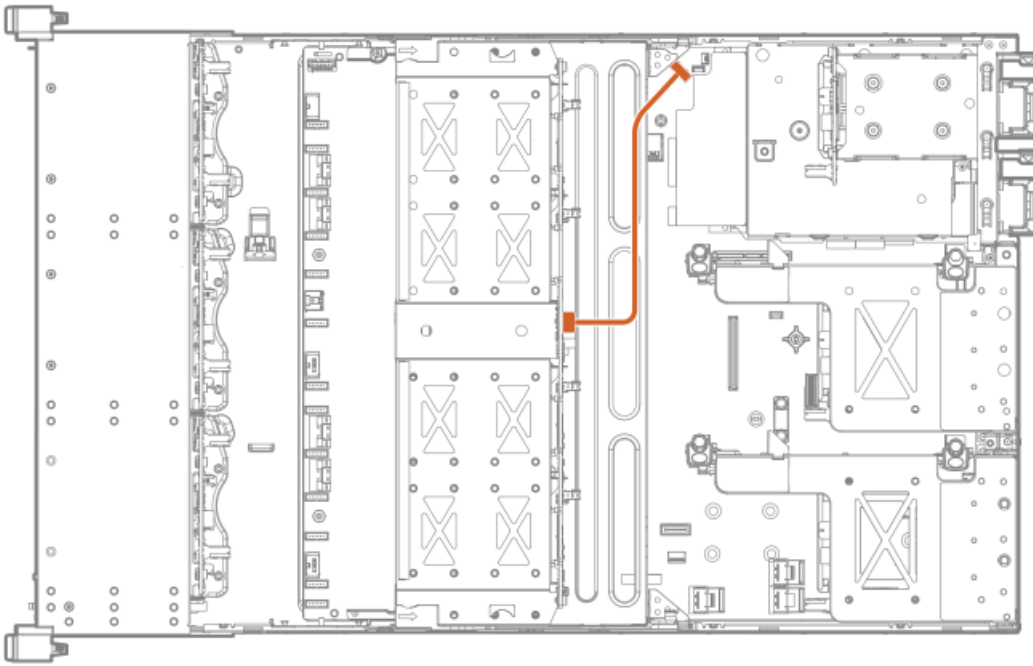

Cable routing: Front 2SFF side-by-side power cabling

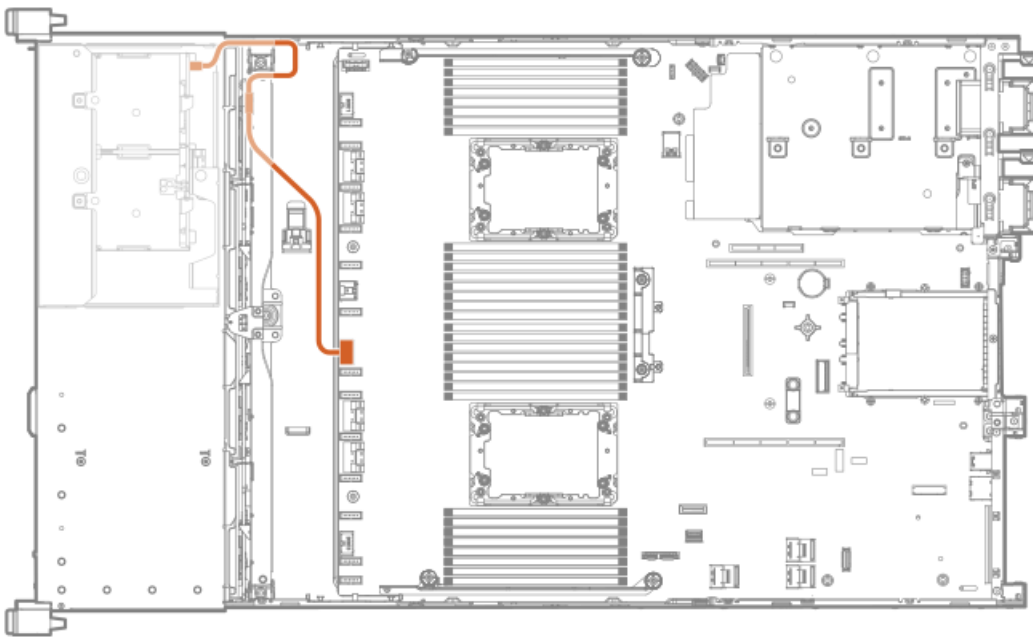

Cable routing: Rear 2SFF power cabling

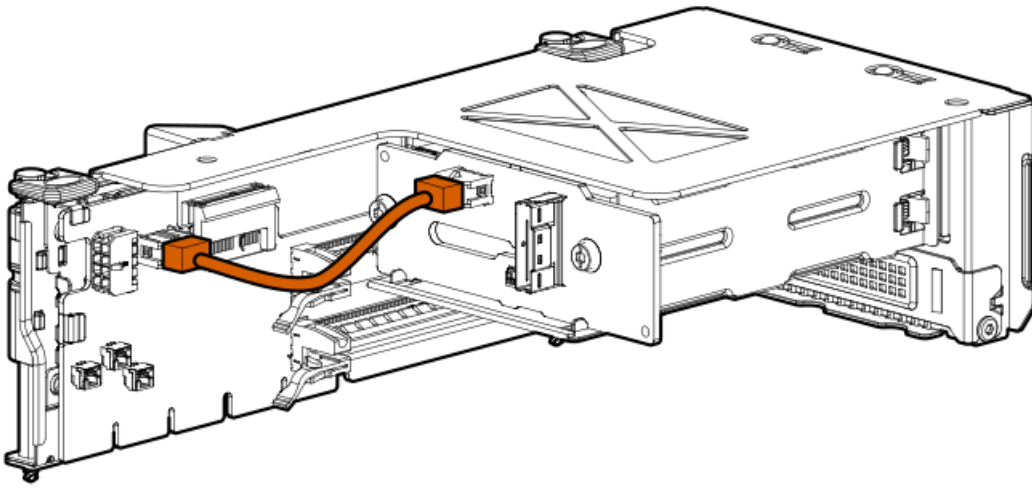

Cabling diagrams

Use the following tables to find cabling information and diagrams.

Table 4: Cable kits

Option kit	Cable part number*	From	To
2SFF stacked	P22903-001	2SFF box 6	AROC to NVMe adapter
2SFF stacked	P22761-001	2SFF stacked	Type-a controller
8SFF SAS/SATA	776402-001	Box 1/2	Type-a/p controller
	747568-001	Box 3	Type-a/p controller
	P14335-001	Box 1/2/3	Type-a/p controller
8NVMe	P22345-001	Box 1/2	System board
		Port 1 and 2	Port 1A-B/2A-B
	P22346-001	Box 2/3	System board
		Port 3-4	Port 1B/2B
	P22347-001	Box 2/3	Type-a controller
		Port 3	
8SFF midplane	P14334-001	Box 7	Type-p controller
		Ports 1-4	
8NVMe midplane	P14329-001	Box 7	Type-p controller
		Port 1	
NVMe direct connect	P14331-001	Box 2	Type-a/p controller
		Ports 1-2	
	P14332-001	Box 2	Type-a/p controller
		Ports 3-4	

Option kit	Cable part number*	From	To
	P14330-001	Box 1/3 Ports 3-4	Primary/tertiary type-p controller
	P14333-001	Box 1/3 Ports 1-2	Primary/tertiary type-p controller
	P14326-001	Box 2 Ports 1-4	Type-p controller
	P14327-001	Box 1 Ports 1-4	Type-p controller
	P14328-001	Box 1 2SFF stacked	Tertiary type-p controller
	P14324-001	Box 2 Ports 1-2	Secondary type-p controller
	P14325-001	Box 2 Ports 3-4	Secondary type-p controller
	P14320-001	Box 3 Ports 1-4	Primary riser
	P14321-001	Box 3 Ports 1-4	Primary type-p controller
	P14322-001	Box 2 Ports 1-4	System board Port 1A-B/2A-B
OCP enablement kit	P14337-001	OCP adapter	Primary riser
	P14339-001	OCP adapter	Secondary riser

Table 5: Front I/O

Cable description	Cable part number	From	To
Display port + USB 2.0	P14314-001	Component	System board
USB to USB Port	P14315-001	Component	System board
Optical Disk Drive, SATA	P14316-001	Component	System board
Serial port	P14317-001	Component	System board

Table 36: Power cables

Cable description	Cable part number	From	To
I/O Wire to Board, FRONT	P14312-001	Backplane	System board
PWR, 1x5 to 2x4, LFF, 240mm	P14341-001	Backplane	System board
PWR, 1x5 to 2x4, LFF, 400mm	P14342-001	Backplane	System board
PWR, 1x5 to 2x4 + x, LFF, 400mm	P14343-001	Backplane	System board

Cable description	Cable part number	From	To
PWR, 2x3 to 2x3, SFF	P14345-001	Backplane	System board
PWR, 2x5 to 2x3 + 2x4	P14346-001	Backplane	System board
PWR, 4LFF/8SFF	869825-001	Backplane	System board

Cable routing: 2NVMe box 6 to AROC NVMe adapter

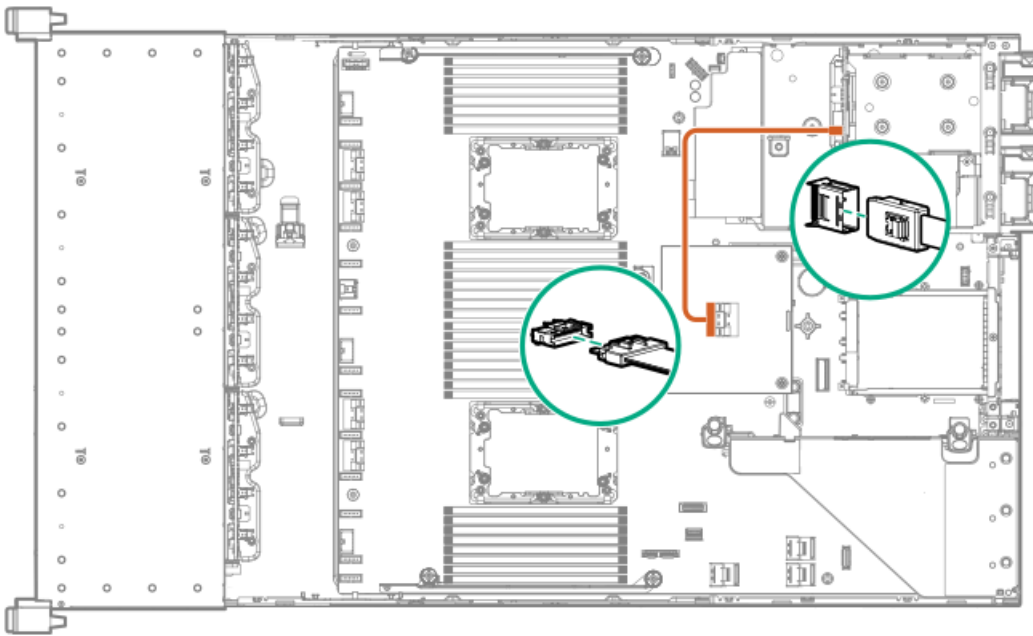

Cable routing: 6NVMe box 3 to 3-port primary riser



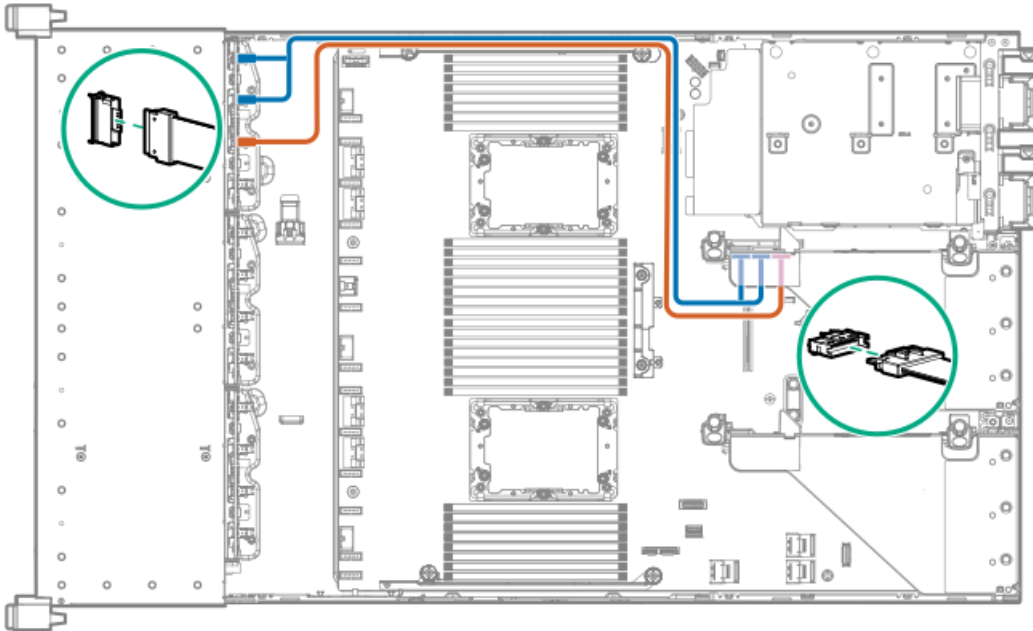

Cable routing: 6 NVMe box 3 to 3-port primary riser

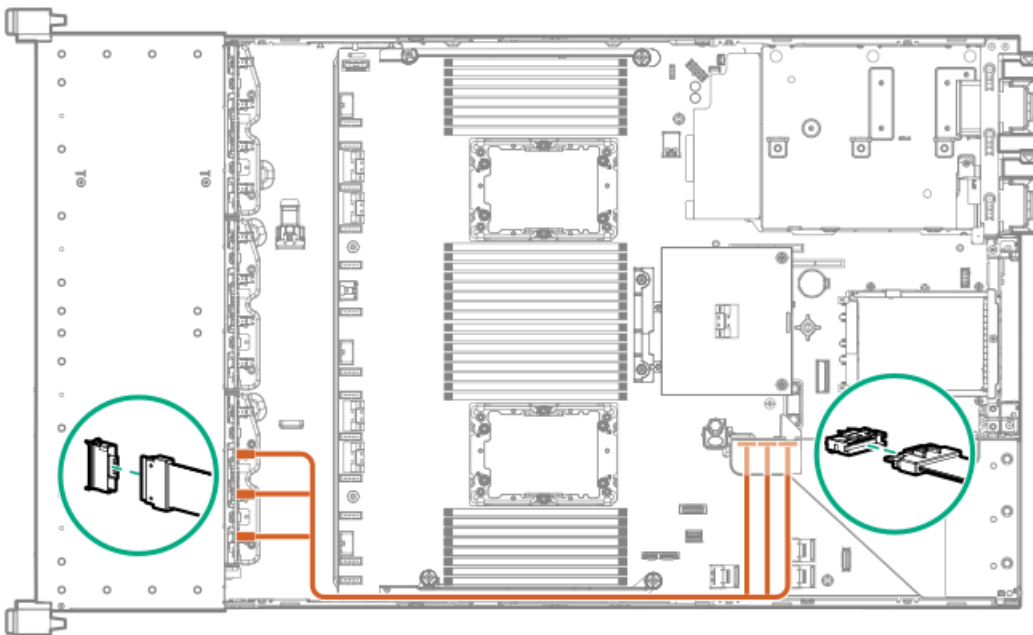

Cable routing: 8 NVMe balanced box 2 to system board

8 NVMe direct attach

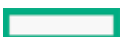

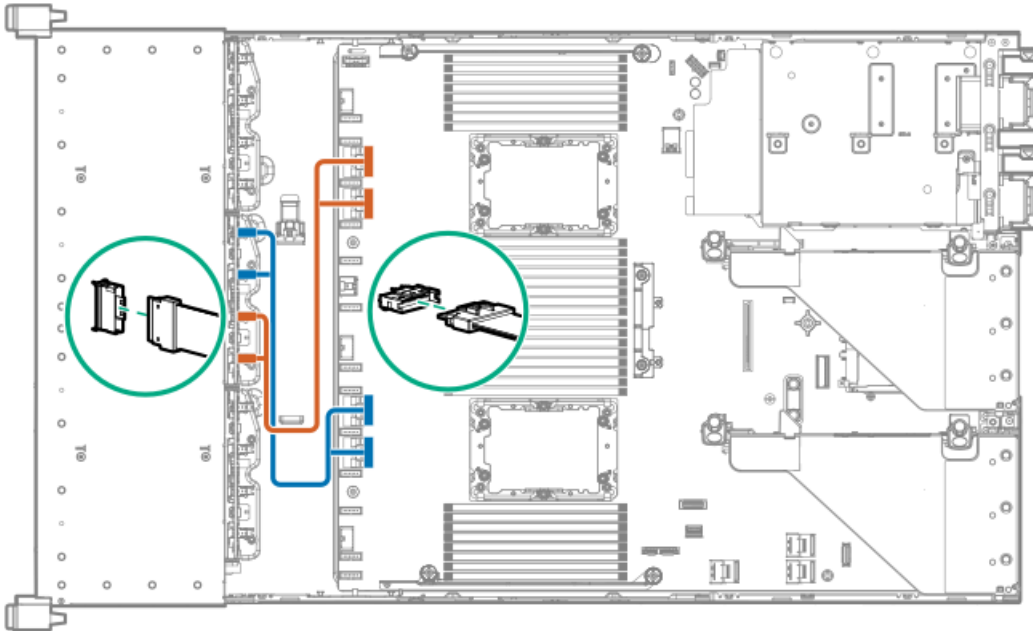

Cable routing: 8NVMe P2 box 1 to system board/secondary riser

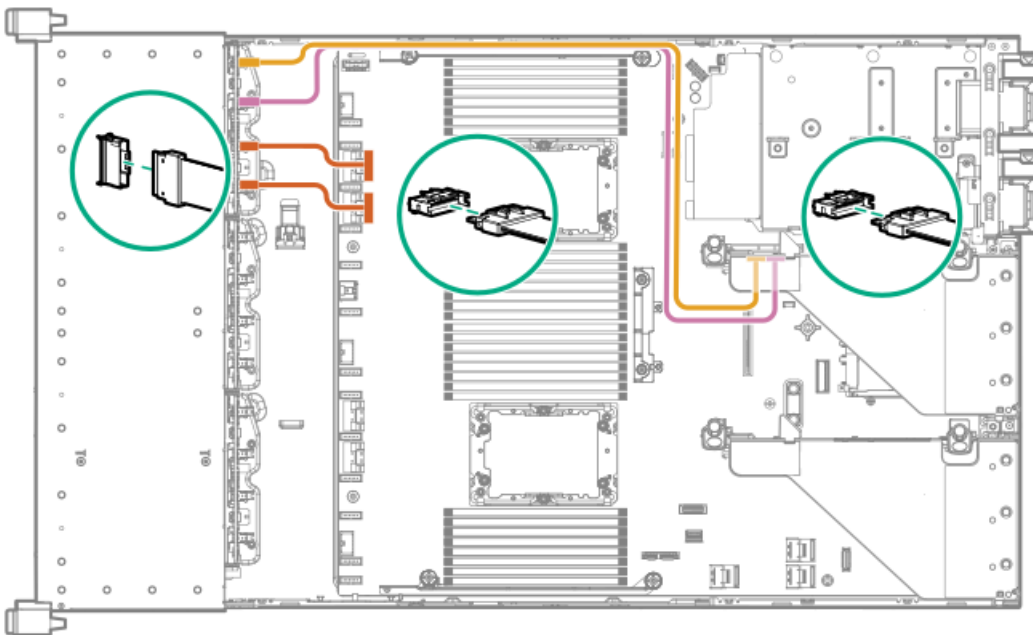

Cable routing: 8NVMe P1 box 3 to system board/primary riser



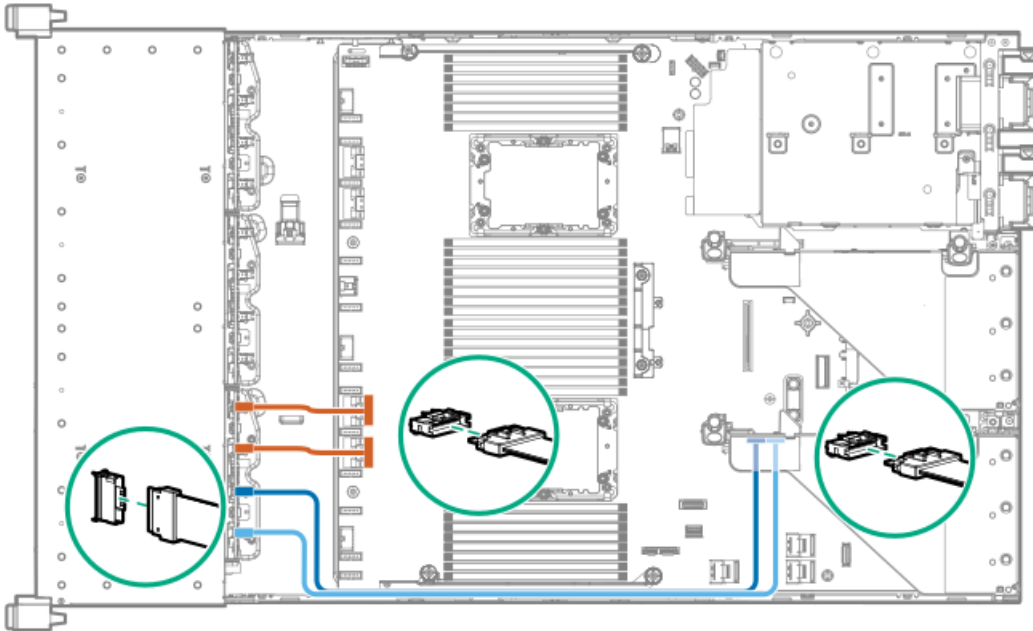

Cable routing: 12NVMe BAL P1 box 2+3 to system board/primary riser/OCP NVMe adapter/Type-a controller

12NVMe P1

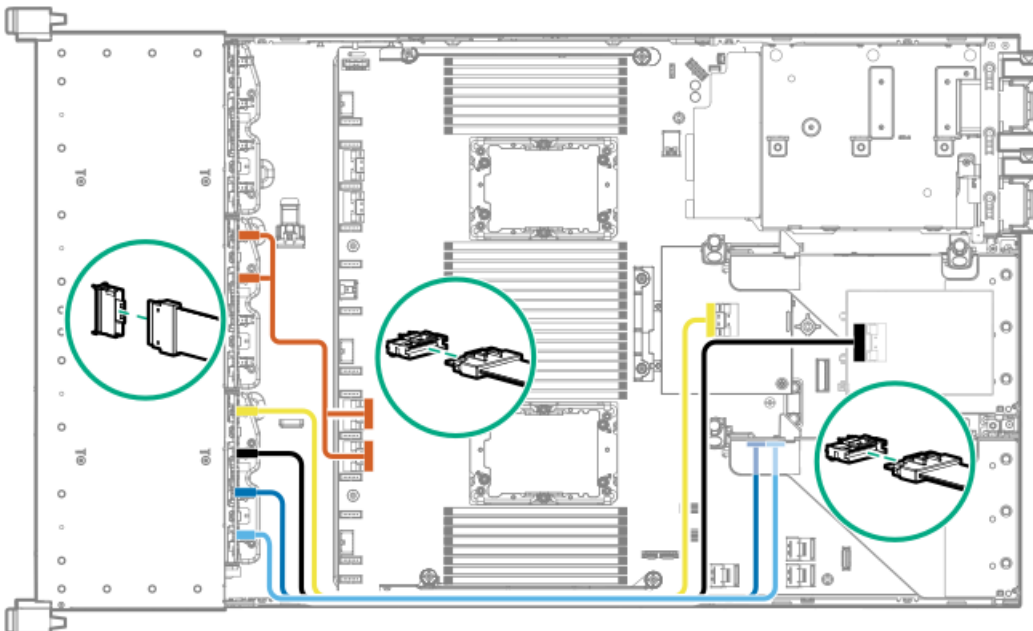

Cable routing: 12NVMe BAL P2 box 1+2 to system board/4-port NVMe secundar riser



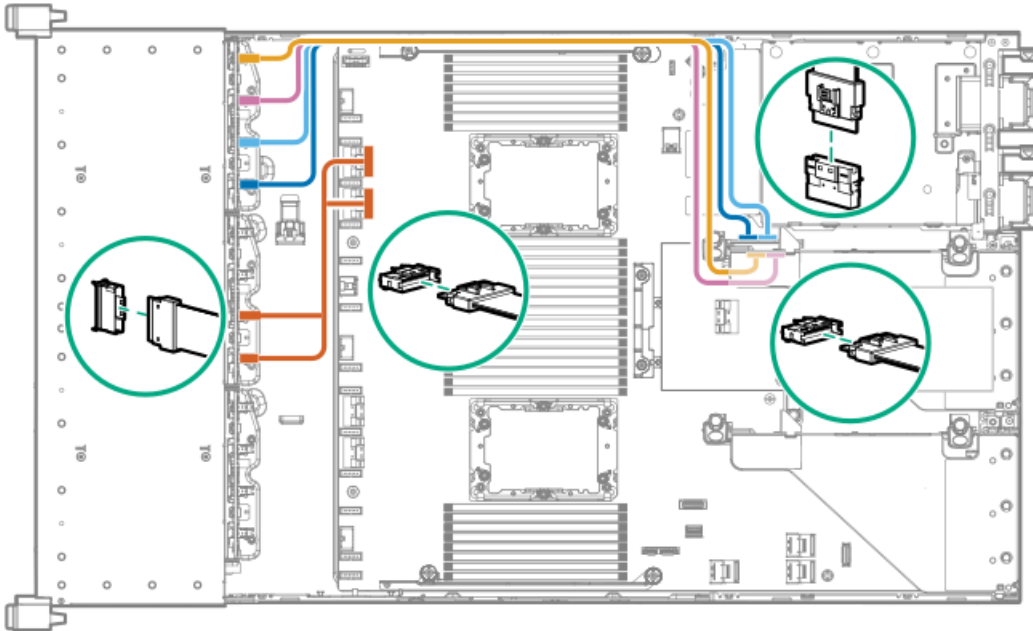

Cable routing: 12NVMe DIFF P1 box 2+3 to system board/4-port NVMe primary riser

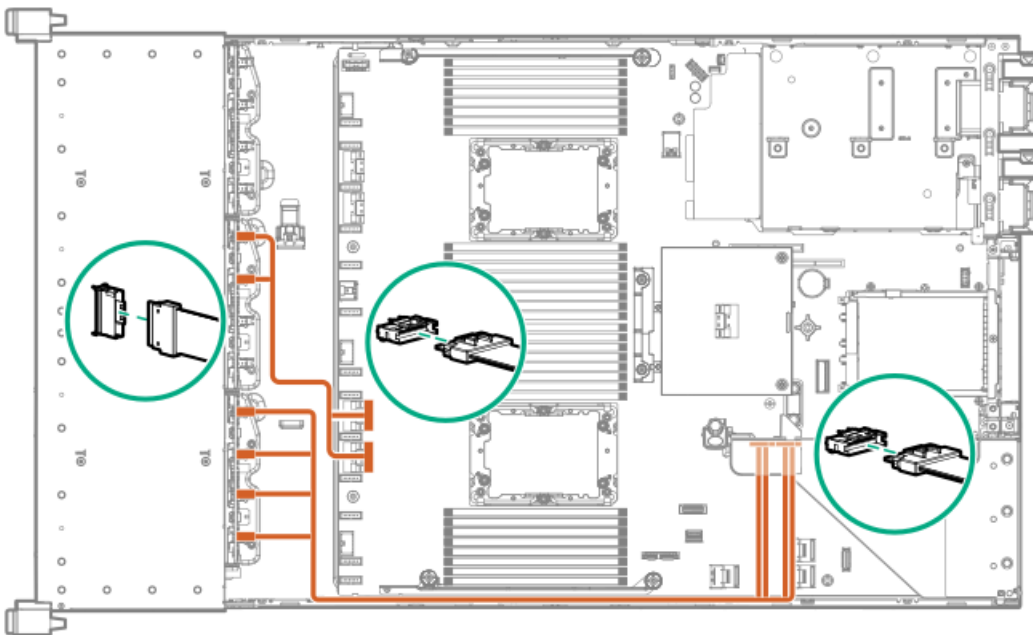

Cable routing: 12NVMe DIFF P1 box 1+2 to system board/4-port NVMe secondary riser

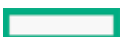

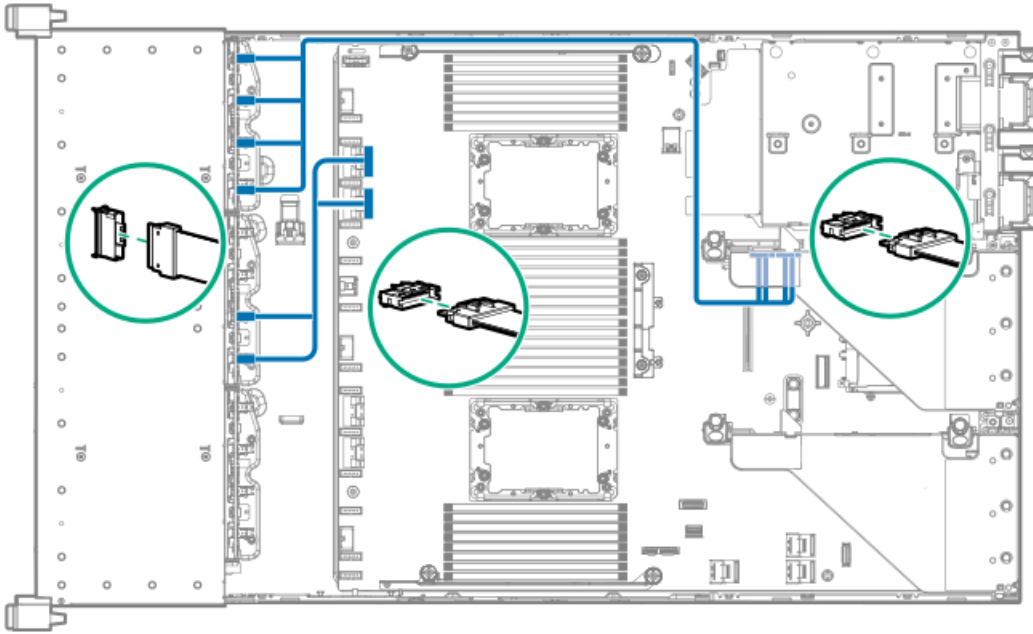

Cable routing: 24 NVMe Balanced

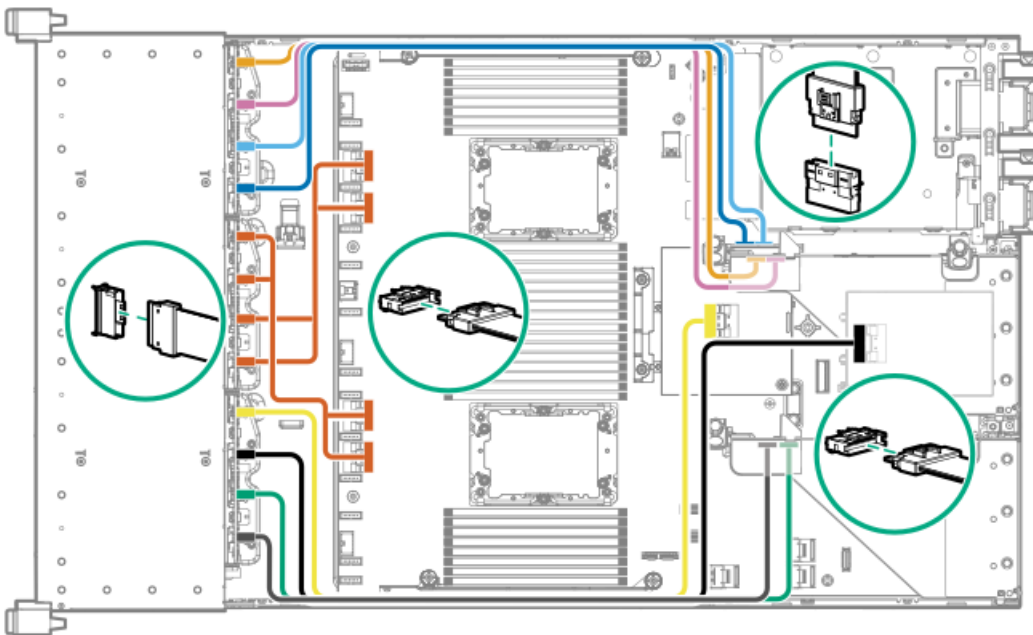

Cable routing: 24 NVMe Differential



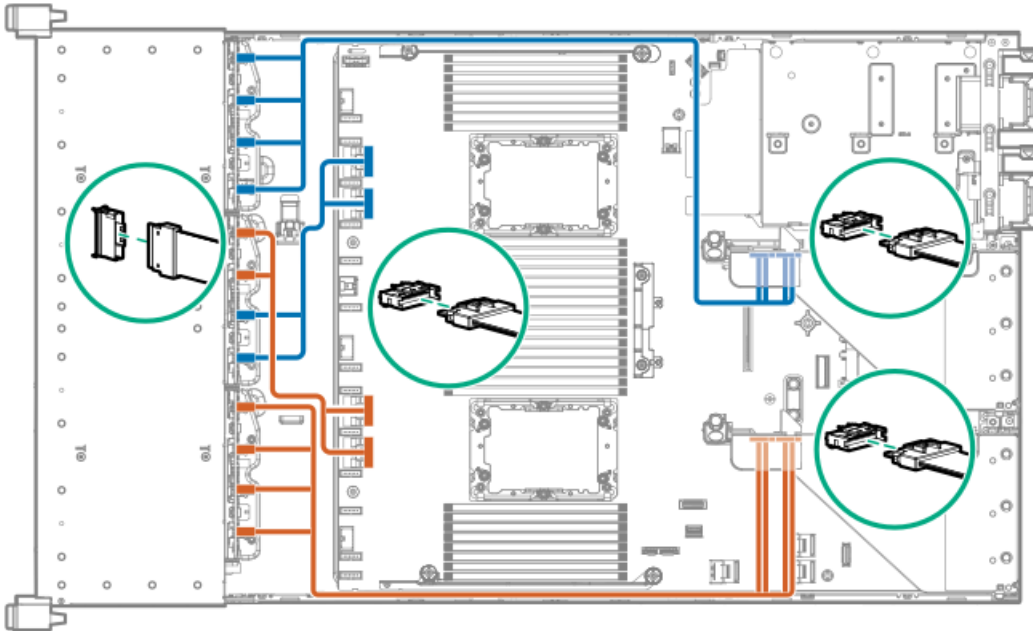

Cable routing: 8NVMe box 3 to 4-port primary riser

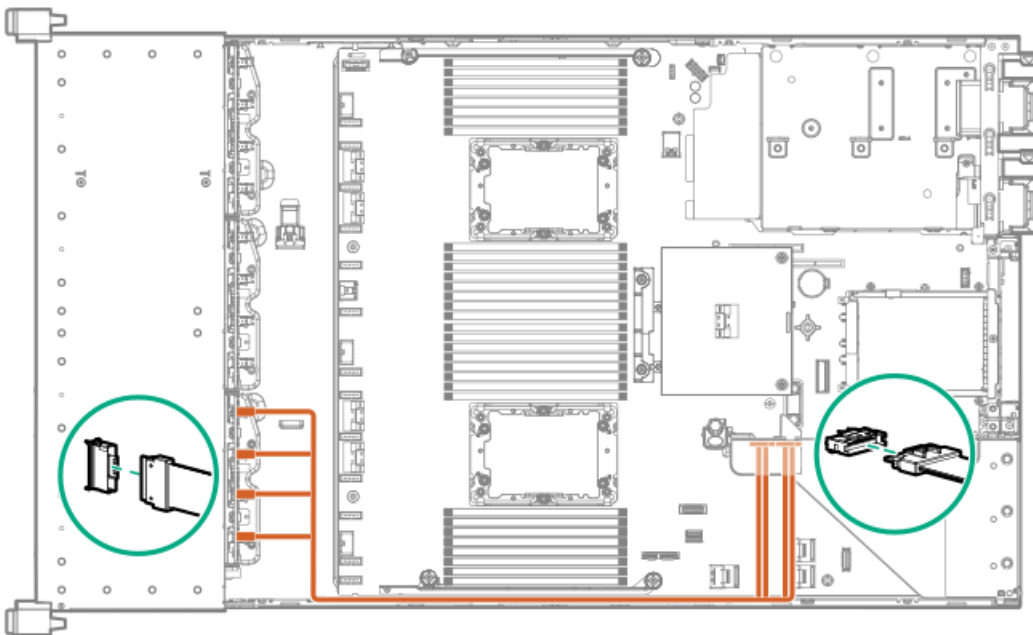

Cable routing: 8NVMe box 1 to 4-port secondary riser



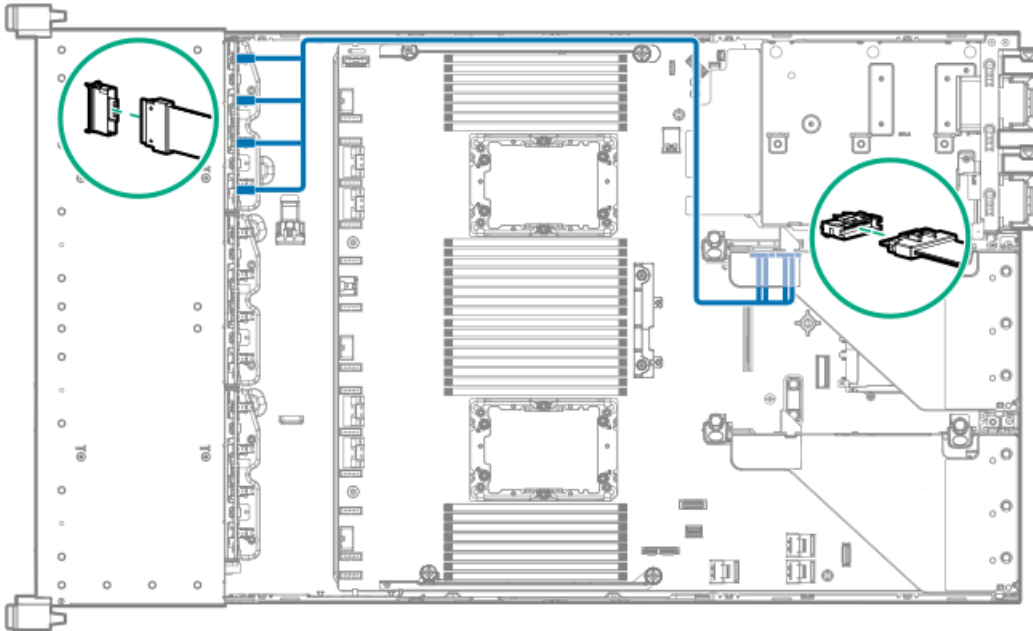

Cable routing: 8NVMe box 1+2 to type-a controller

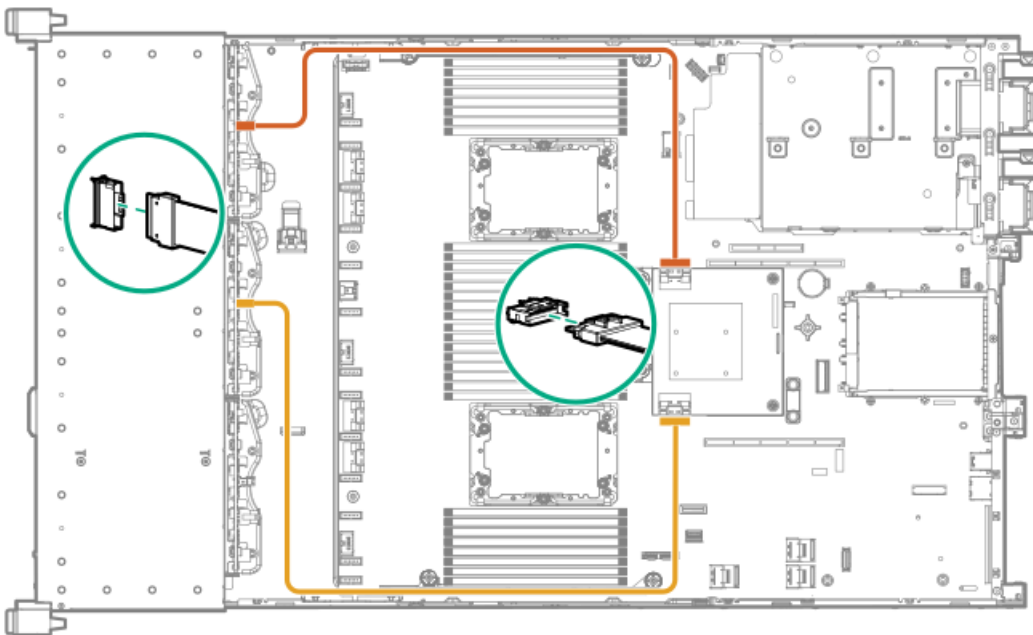

Cable routing: 8SFF box 2 to type-a controller



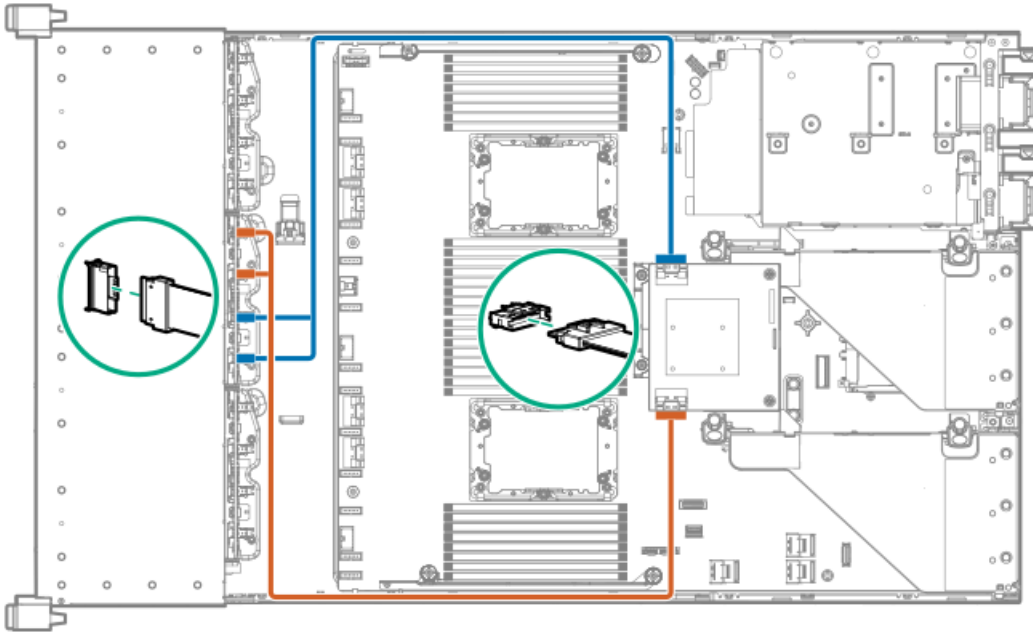

Cable routing: 8SFF box 3 to 2-port primary type-p controller

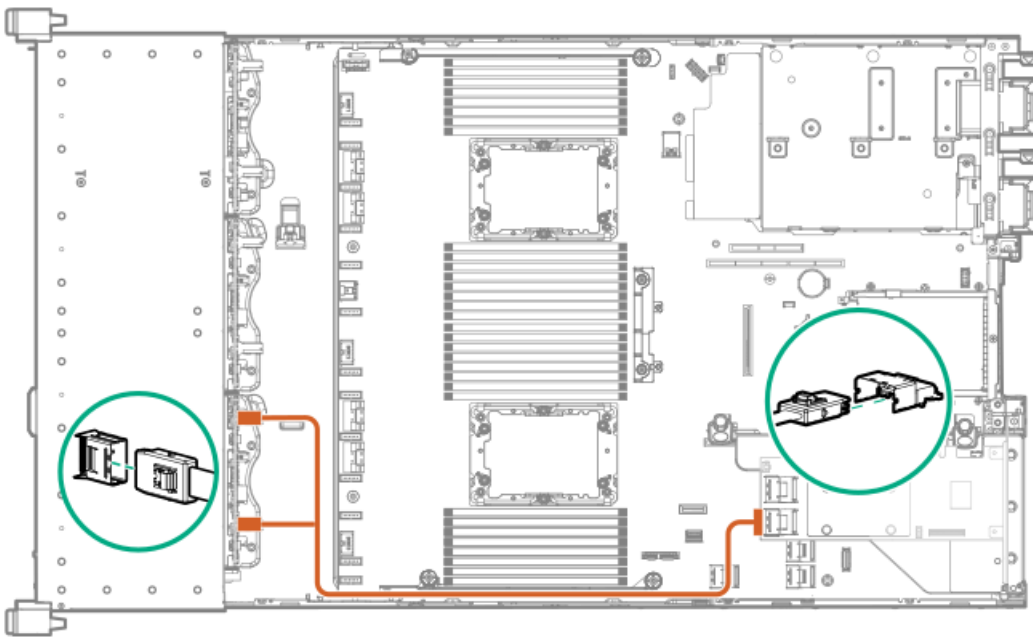

Cable routing: 8SFF box 2 to 2-port primary type-p controller



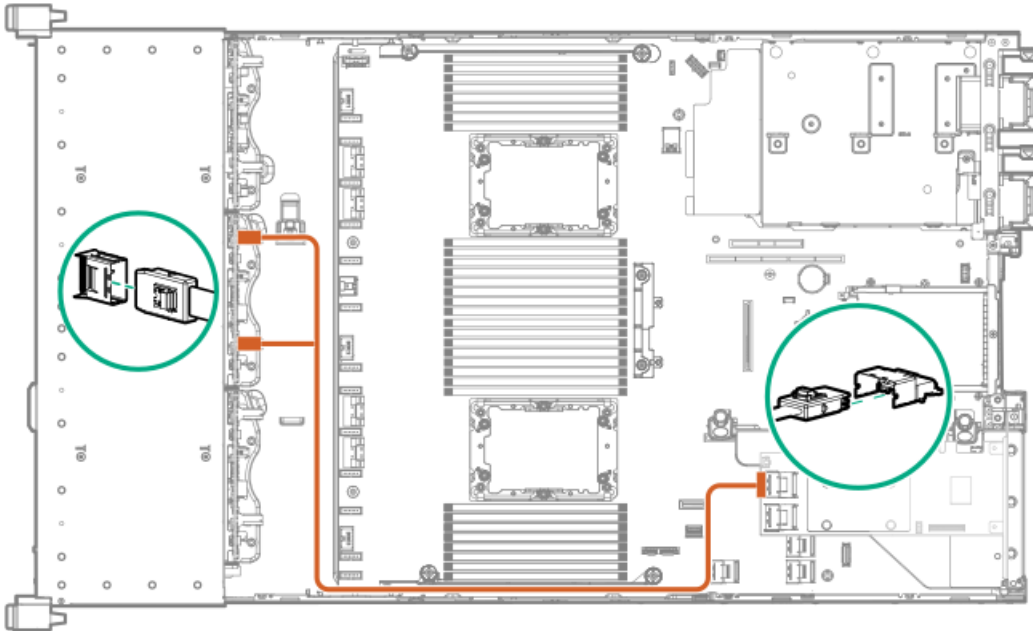

Cable routing: 2SFF side-by-side to primary type-p controller

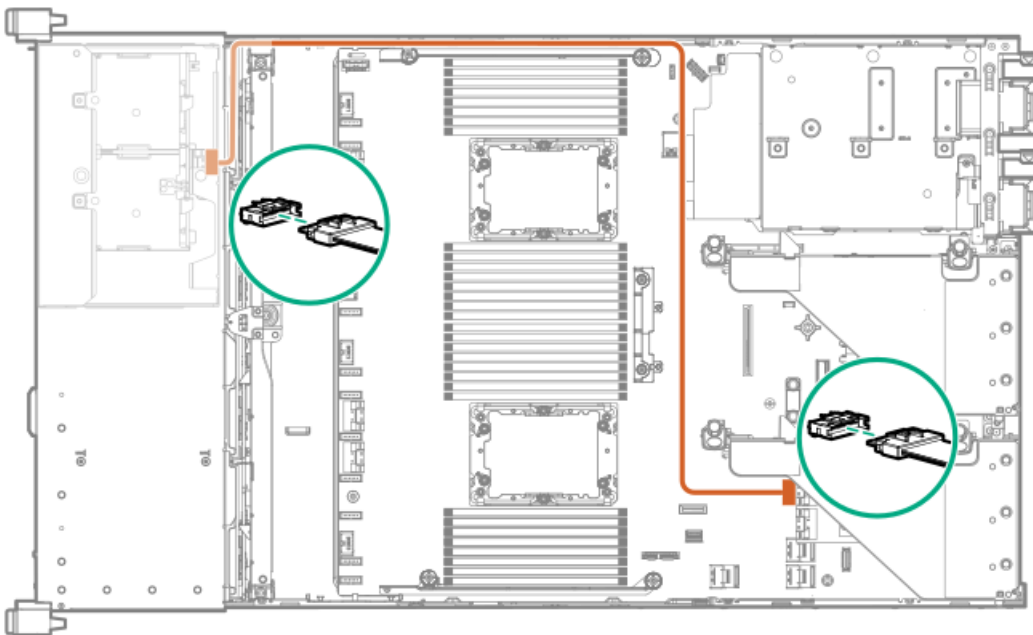

Cable routing: 8SFF 4-port box 1 to 4-port secondary type-p controller



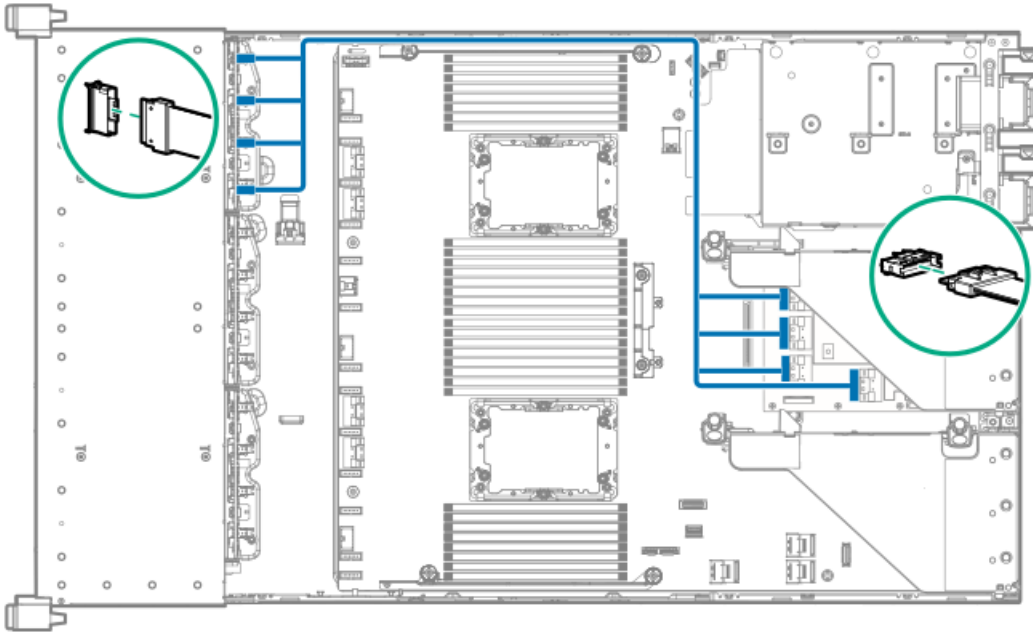

Cable routing: 8SFF 4-port box 2 to 4-port primary type-p controller

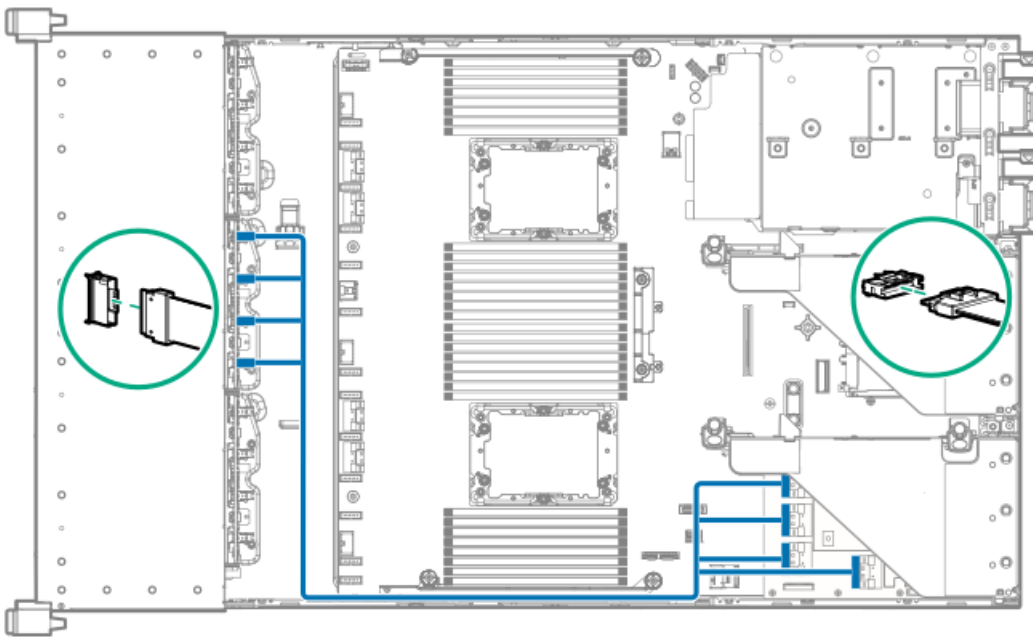

Cable routing: 8SFF 4-port box 3 to 4-port primary DL type-p controller

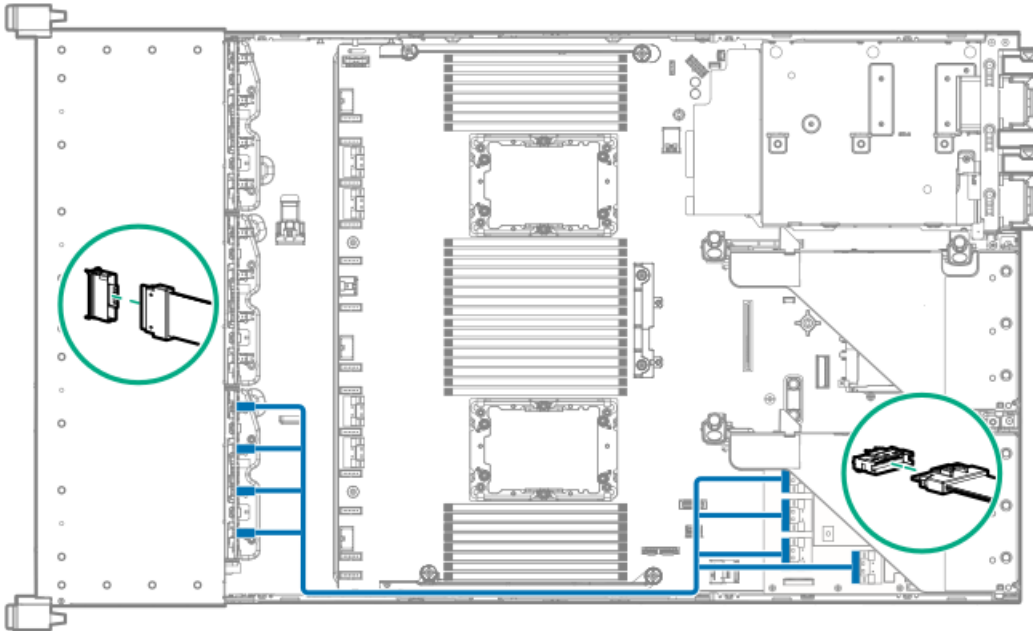

Cable routing: 8SFF box 1+2+3 to 4-port secondary type-p controller

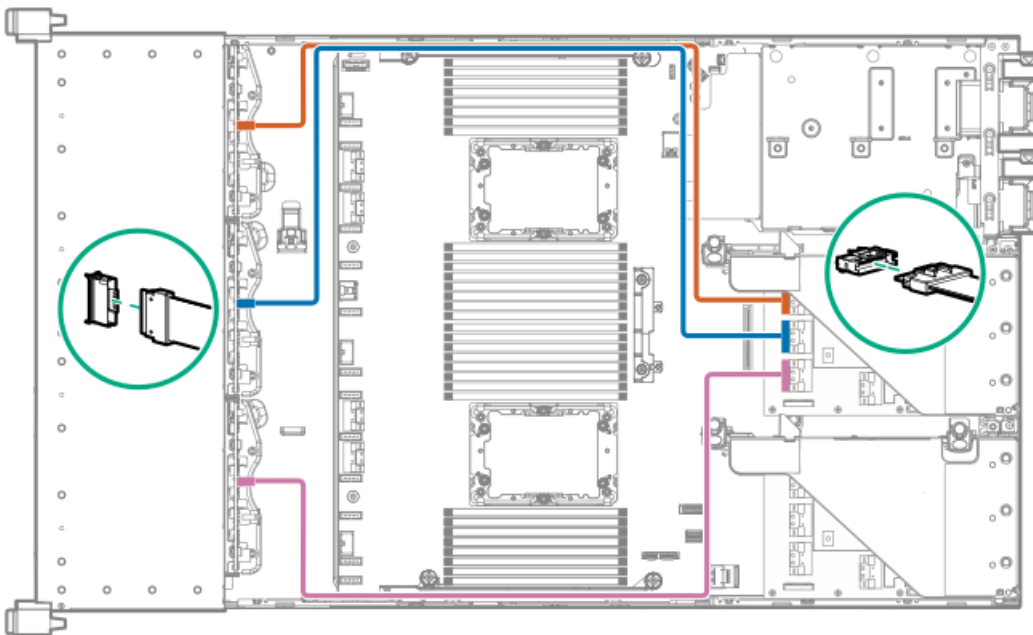

Cable routing: 8SFF box 1+2+3 to 4-port primary type-p controller

8SFF



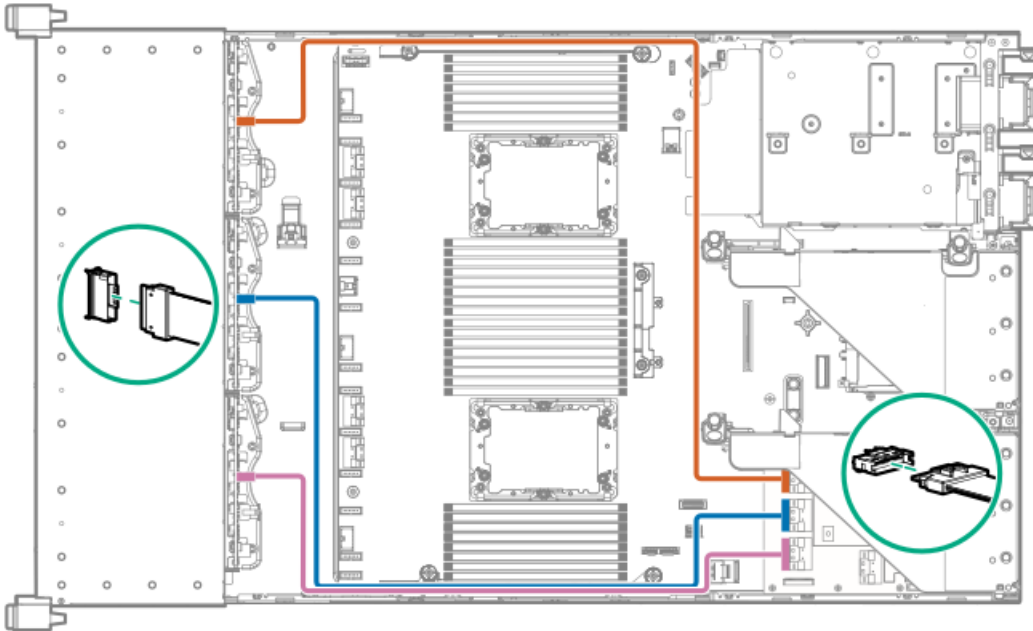

Cable routing: 4LFF SAS/SATA box 7 to 4-port type-a controller

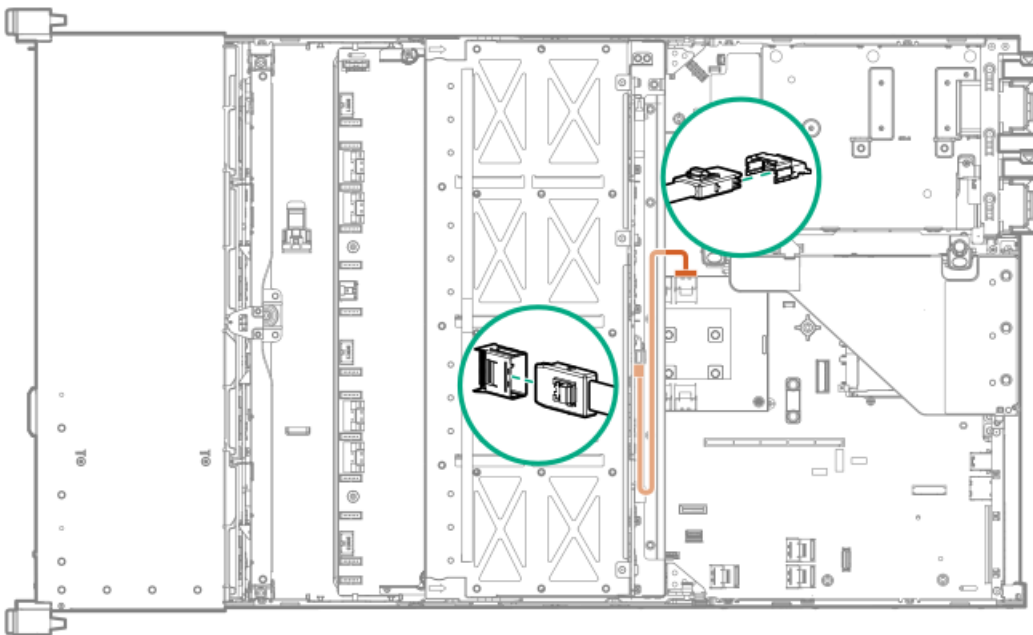

Cable routing: Front I/O cabling

SFF Universal Media Bay Display Port



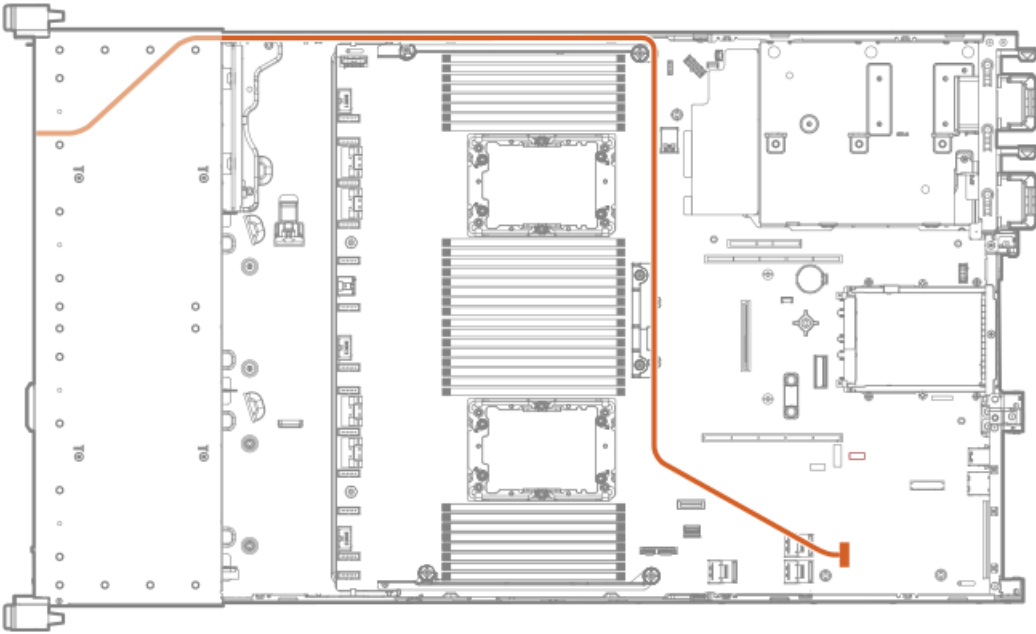

SFF Universal Media Bay USB to system board

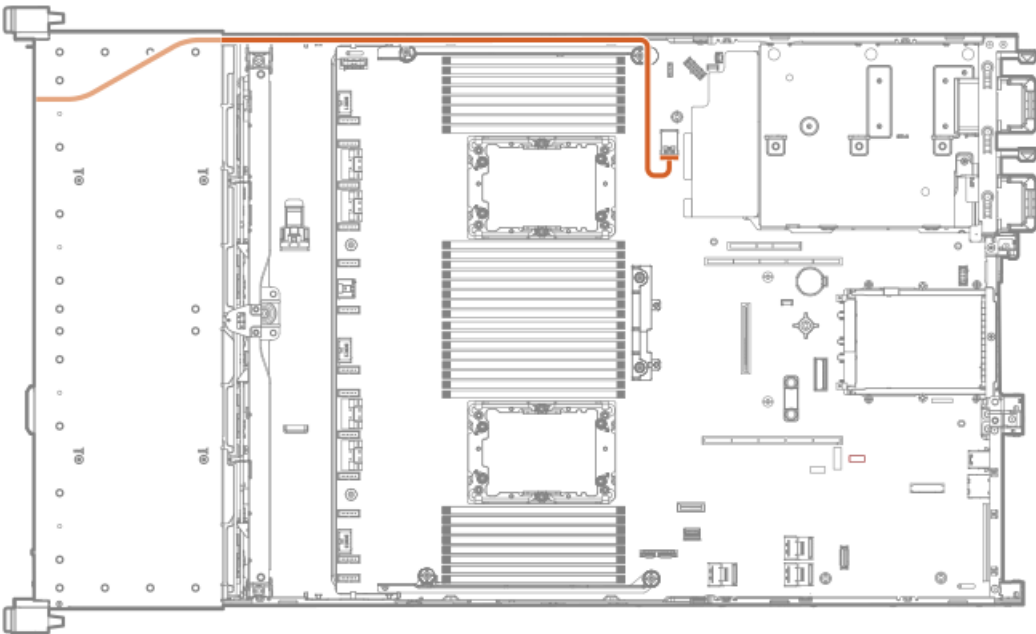

SFF Universal Media Bay optical disk drive



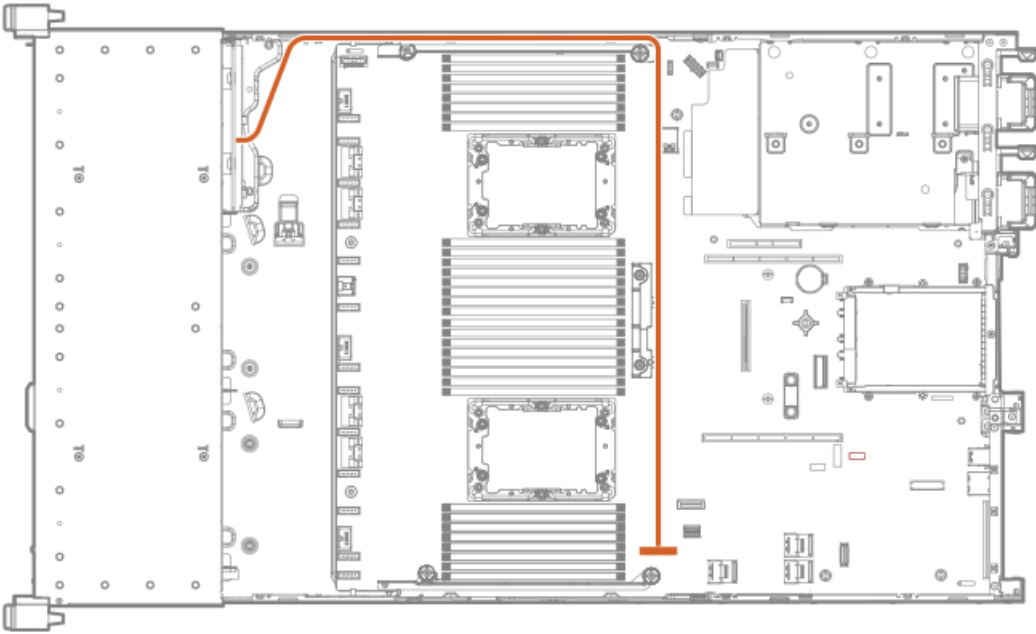

SFF/LFF power switch

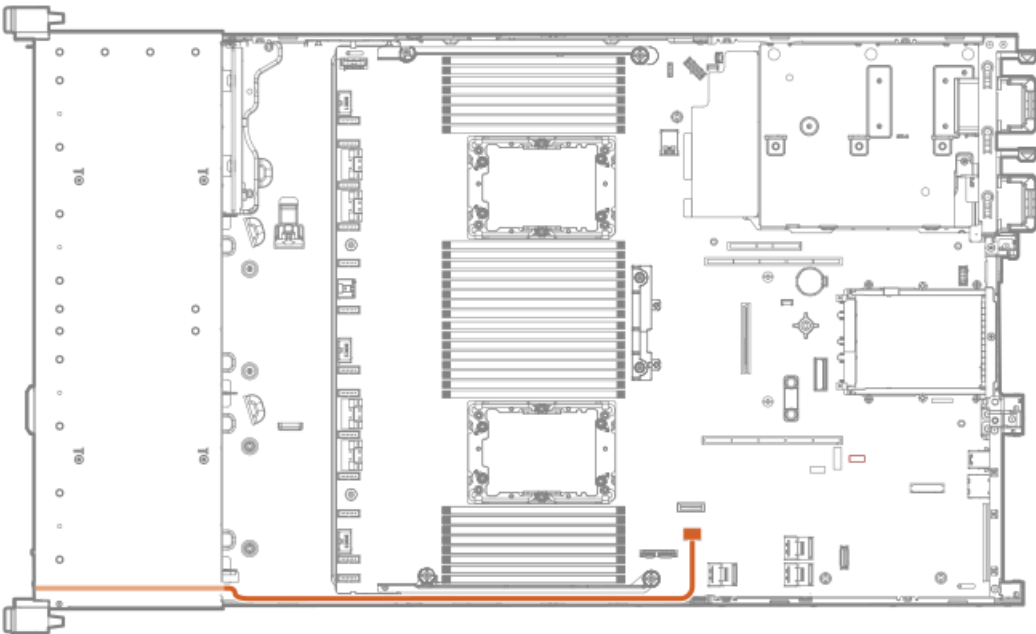

SFF/LFF Systems Insight Display



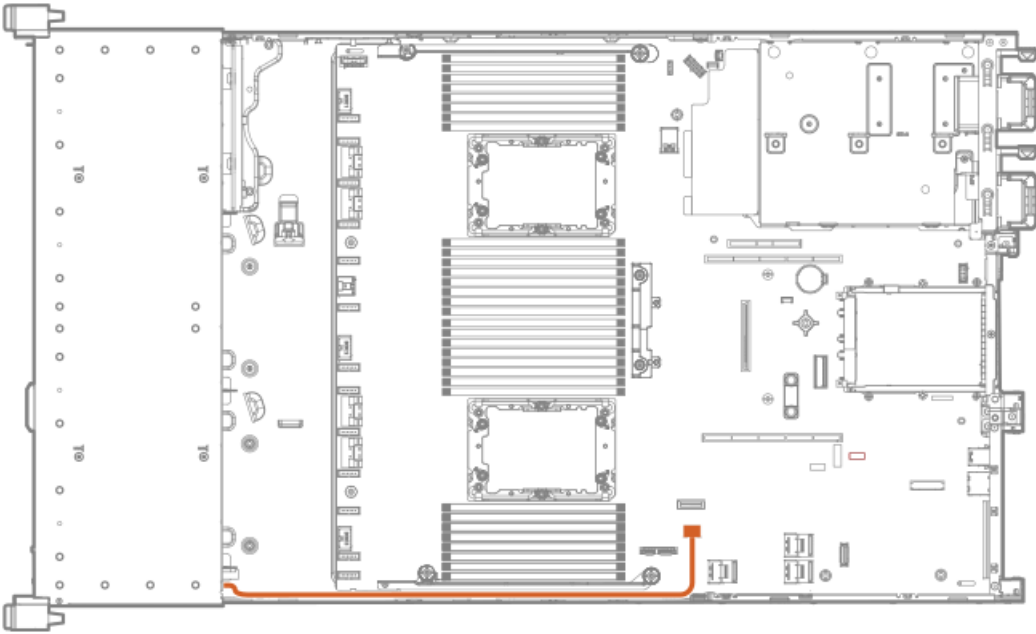

LFF optical disk drive

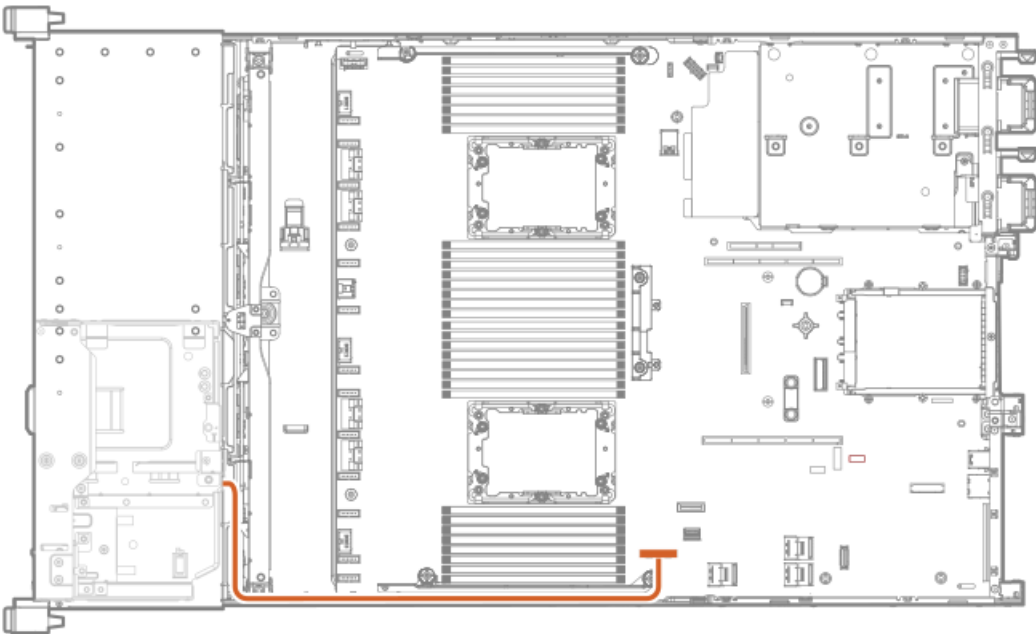

LFF display port



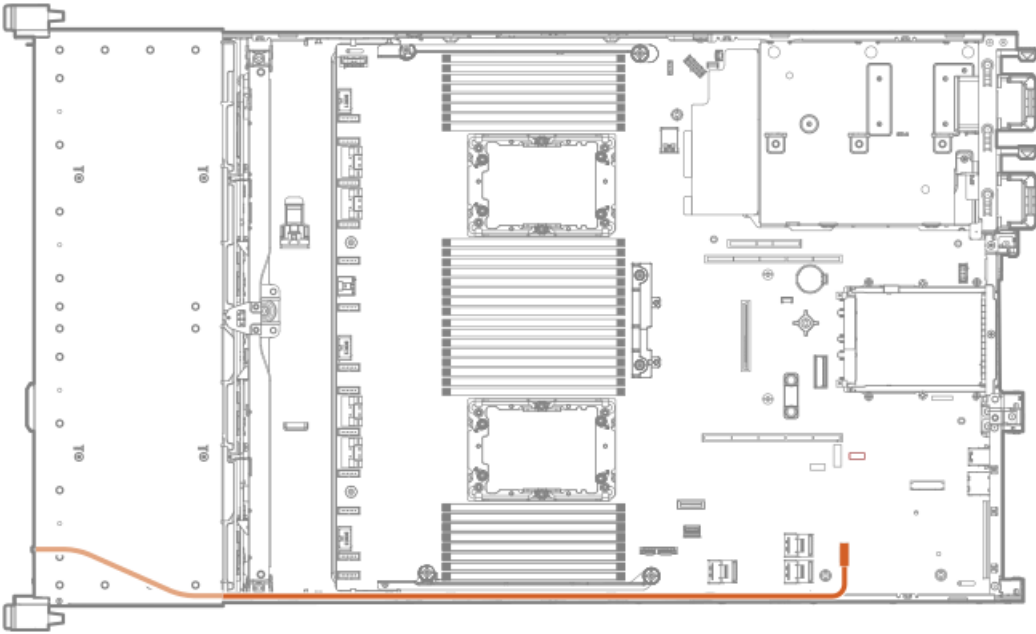

LFF power switch module

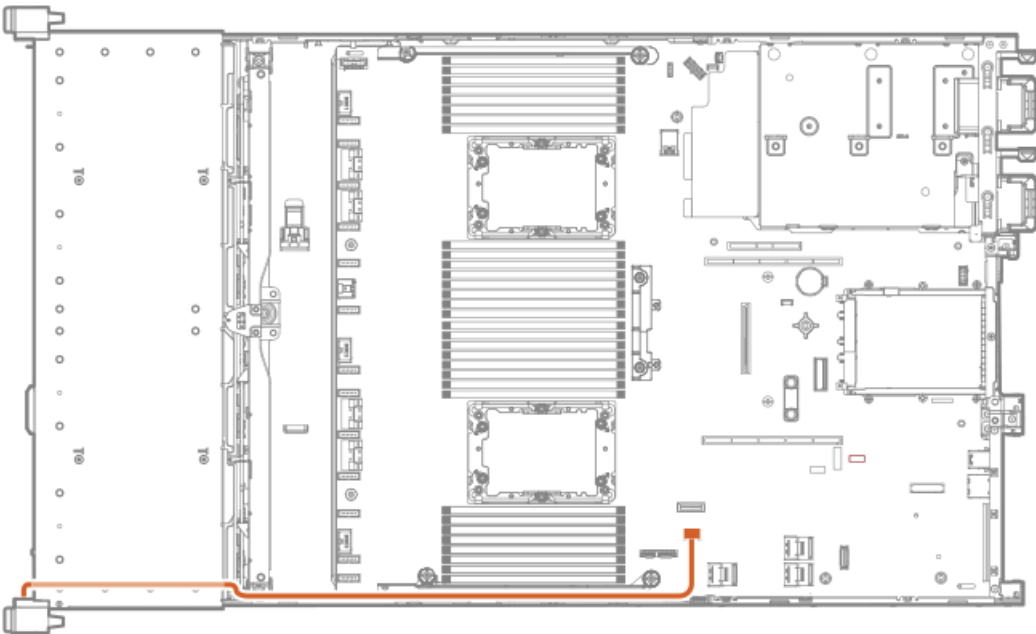

Cable routing: Serial port

Standard



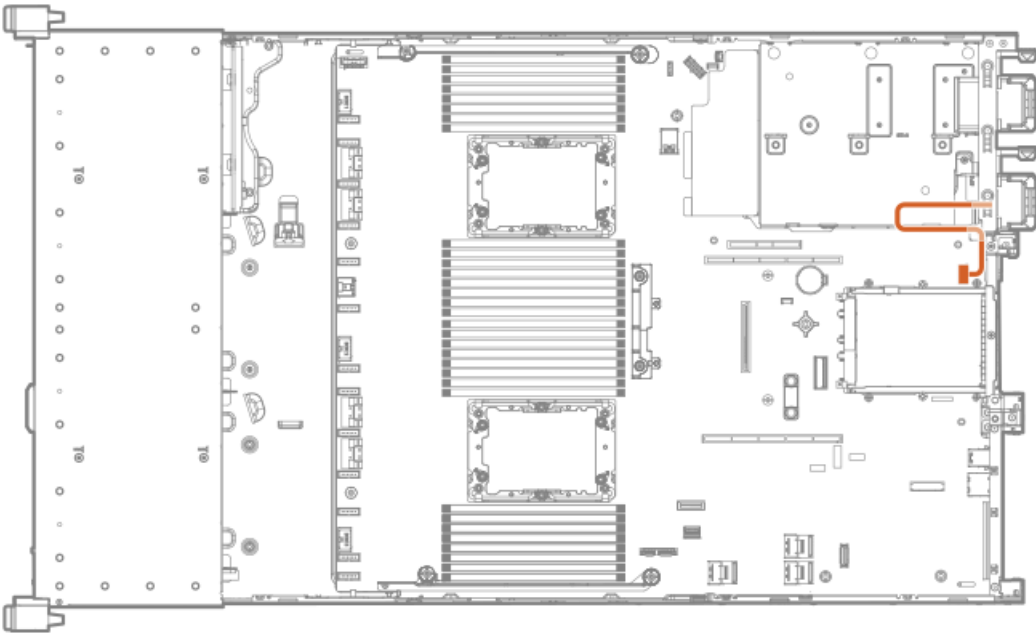

Tertiary riser

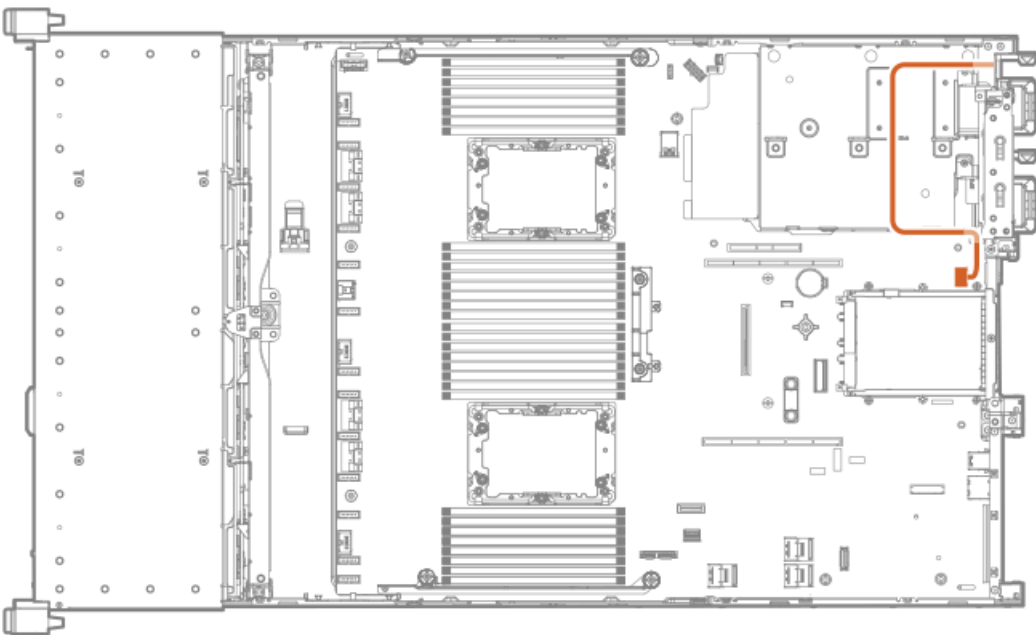

Cable routing: OCP NVMe enablement



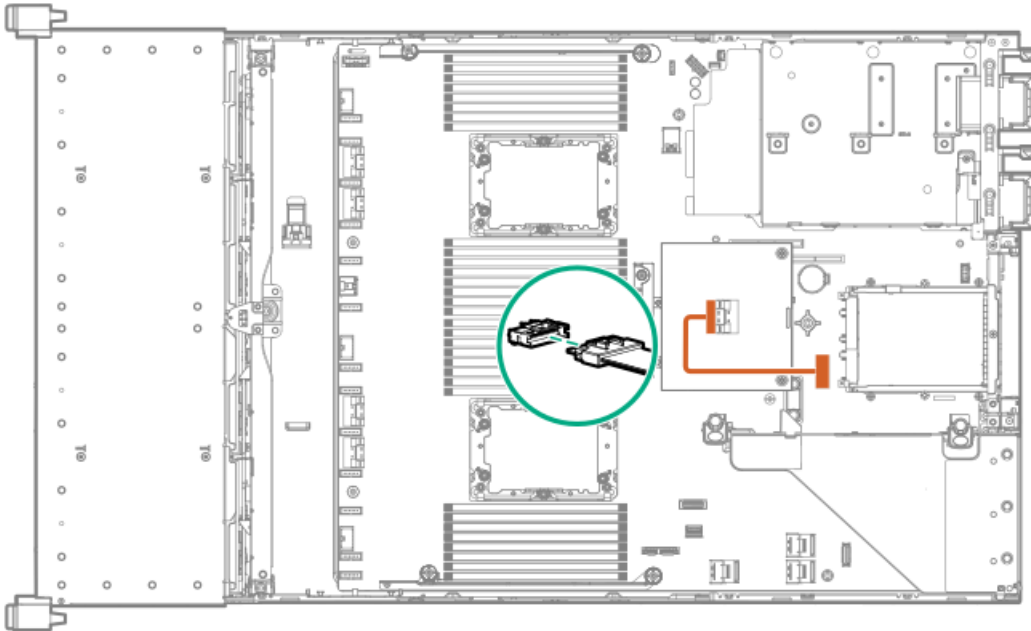

Specifications

For more information on cable, power, environmental, compliance, and general specifications, see the [HPE Compute Transceiver and Cable Hardware Matrix](#).

Environmental specifications

Specification	Value
Temperature range ¹	—
Operating	10°C to 35°C (50°F to 95°F)
Nonoperating	-30°C to 60°C (-22°F to 140°F)
Relative humidity (noncondensing)	—
Operating	Minimum to be the higher (more moisture) of -12°C (10.4°F) dew point or 8% relative humidity Maximum to be 24°C (75.2°F) dew point or 90% relative humidity
Nonoperating	5% to 95% 38.7°C (101.7°F), maximum wet bulb temperature

¹ All temperature ratings shown are for sea level. An altitude derating of 1.0°C per 304.8 m (1.8°F per 1000 ft) to 3048 m (10,000 ft) is applicable. No direct sunlight allowed. Maximum rate of change is 20°C per hour (36°F per hour). The upper limit and rate of change might be limited by the type and number of options installed.

For certain approved hardware configurations, the supported system inlet temperature range is extended:

- 5°C to 10°C (41°F to 50°F) and 35°C to 40°C (95°F to 104°F) at sea level with an altitude derating of 1.0°C per every 175 m (1.8°F per every 574 ft) above 900 m (2953 ft) to a maximum of 3048 m (10,000 ft).

- 40°C to 45°C (104°F to 113°F) at sea level with an altitude derating of 1.0°C per every 125 m (1.8°F per every 410 ft) above 900 m (2953 ft) to a maximum of 3048 m (10,000 ft).

The approved hardware configurations for this system are listed on the [Hewlett Packard Enterprise website](#).

Mechanical specifications

Specification	Value
Height	8.75 cm (3.44 in)
Depth, SFF	71.2 cm (28.00 in)
Depth, LFF	74.9 cm (29.50 in)
Width	44.54 cm (17.54 in)
Weight, SFF minimum	16.12 kg (35.54 lbs)
Weight, SFF maximum	28.77 kg (63.43 lbs)
Weight, LFF minimum	22.48 kg (49.56 lbs)
Weight, LFF maximum	33.99 kg (74.94 lbs)

Power supply specifications

Depending on the installed options and the regional location where the server was purchased, the server can be configured with one of the following power supplies:

- [HPE 800 W Flex Slot Universal Hot-plug Low Halogen Power Supply](#)
- [HPE 800 W Flex Slot Platinum Hot-plug Low Halogen Power Supply](#)
- [HPE 800 W Flex Slot Titanium Hot-plug Low Halogen Power Supply](#)
- [HPE 800 W Flex Slot -48 VDC Hot-plug Low Halogen Power Supply](#)
- [HPE 1600 W Flex Slot Platinum Hot-plug Low Halogen Power Supply](#)
- [HPE 1600 W Flex Slot -48 VDC Hot-plug Power Supply](#)

For detailed power supply specifications, see the QuickSpecs on the [Hewlett Packard Enterprise website](#).

HPE 800 W Flex Slot Universal Hot-plug Low Halogen Power Supply

Specification	Value
Input requirements	—
Rated input voltage	200 VAC to 277 VAC 380 VDC
Rated input frequency	50 Hz to 60 Hz

Specification	Value
Rated input current	4.4 A at 200 VAC
	3.8 A at 230 VAC
	2.3 A at 380 VDC
Maximum rated input power	869 W at 200 VAC
	865 W at 230 VAC
	861 W at 277 VAC
	863 W at 380 VDC
BTUs per hour	2964 at 200 VAC
	2951 at 230 VAC
	2936 at 277 VAC
	2943 at 380 VDC
Power supply output	—
Rated steady-state power	800 W at 200 VAC to 277 VAC input
Maximum peak power	800 W at 200 VAC to 277 VAC input

HPE 800 W Flex Slot Platinum Hot-plug Low Halogen Power Supply

Specification	Value
Input requirements	—
Rated input voltage	100 VAC to 127 VAC
	200 VAC to 240 VAC
	240 VDC for China only
Rated input frequency	50 Hz to 60 Hz
	Not applicable to 240 VDC
Rated input current	9.1 A at 100 VAC
	4.4 A at 200 VAC
	3.6 A at 240 VDC for China only
Maximum rated input power	899 W at 100 VAC
	867 W at 200 VAC
	864 W at 240 VDC for China only
BTUs per hour	3067 at 100 VAC
	2958 at 200 VAC
	2949 at 240 VAC for China only
Power supply output	—

Specification	Value
Rated steady-state power	800 W at 100 VAC to 127 VAC input
	800 W at 100 VAC to 240 VAC input
	800 W at 240 VDC input for China only
Maximum peak power	800 W at 100 VAC to 127 VAC input
	800 W at 100 VAC to 240 VAC input
	800 W at 240 VDC input for China only

HPE 800 W Flex Slot Titanium Hot-plug Low Halogen Power Supply

Specification	Value
Input requirements	—
Rated input voltage	200 VAC to 240 VAC
	240 VDC for China only
Rated input frequency	50 Hz to 60 Hz
	Not applicable to 240 VDC
Rated input current	4.3 A at 200 VAC
	3.6 A at 240 VAC
	3.6 A at 240 VDC for China only
Maximum rated input power	851 W at 200 VAC
	848 W at 240 VAC
	848 W at 240 VDC for China only
BTUs per hour	2905 at 200 VAC
	2893 at 240 VAC
	2893 at 240 VDC for China only
Power supply output	—
Rated steady-state power	800 W at 200 VAC to 240 VAC input
	800 W at 240 VDC input for China only
Maximum peak power	800 W at 200 VAC to 240 VAC input
	800 W at 240 VDC input for China only

HPE 800 W Flex Slot -48 VDC Hot-plug Low Halogen Power Supply

Specification	Value
---------------	-------

Specification	Value
Input requirements	—
Rated input voltage	-40 VDC to -72 VDC -48 VDC nominal input
Rated input current	22.1 A at -40 VDC input 18.2 A at -48 VDC input, nominal input 12.0 A at -72 VDC input
Rated input power (W)	874 W at -40 VDC input 865 W at -48 VDC input, nominal input 854 W at -72 VDC input
Rated input power (BTUs per hour)	2983 at -40 VDC input 2951 at -48 VDC input, nominal input 2912 at -72 VDC input
Power supply output	—
Rated steady-state power (W)	800 W at -40 VDC to -72 VDC
Maximum peak power (W)	800 W at -40 VDC to -72 VDC
Maximum peak power	800 W at -40 VDC to -72 VDC input

⚠ WARNING: To reduce the risk of electric shock or energy hazards:

- This equipment must be installed by trained service personnel.
- Connect the equipment to a reliably grounded secondary circuit source. A secondary circuit has no direct connection to a primary circuit and derives its power from a transformer, converter, or equivalent isolation device.
- The branch circuit overcurrent protection must be rated 27 A.

⚠ CAUTION: This equipment is designed to permit the connection of the earthed conductor of the DC supply circuit to the earthing conductor at the equipment.

If this connection is made, all of the following must be met:

- This equipment must be connected directly to the DC supply system earthing electrode conductor or to a bonding jumper from an earthing terminal bar or bus to which the DC supply system earthing electrode conductor is connected.
- This equipment must be located in the same immediate area (such as adjacent cabinets) as any other equipment that has a connection between the earthed conductor of the same DC supply circuit and the earthing conductor, and also the point of earthing of the DC system. The DC system must be earthed elsewhere.
- The DC supply source is to be located within the same premises as the equipment.
- Switching or disconnecting devices must not be in the earthed circuit conductor between the DC source and the point of connection of the earthing electrode conductor.

HPE 1600 W Flex Slot Platinum Hot-plug Low Halogen Power Supply

Specification	Value
---------------	-------

Specification	Value
Input requirements	—
Rated input voltage	200 VAC to 240 VAC 240 VDC for China only
Rated input frequency	50 Hz to 60 Hz
Rated input current	8.7 A at 200 VAC 7.5 A at 230 VAC
Maximum rated input power	1734 W at 200 VAC 1727 W at 230 VAC
BTUs per hour	5918 at 200 VAC 5891 at 230 VAC
Power supply output	—
Rated steady-state power	1600 W at 200 VAC to 240 VAC input 1600 W at 240 VDC input
Maximum peak power	2200 W for 1 ms (turbo mode) at 200 VAC to 240 VAC input

HPE 1600 W Flex Slot -48 VDC Hot-plug Power Supply

Specification	Value
Input requirements	—
Rated input voltage	-40 VDC to -72 VDC
Rated input frequency	DC
Nominal input current	44.2 A DC at -40 VDC input 36.6 A DC at -48 VDC input 24.4 A DC at -72 VDC input
Maximum Rated Input Wattage Rating	1766 W at -40 VDC input 1758 W at -48 VDC input 1755 W at -72 VDC input
BTUs per hour	6026 at -40 VDC input 6000 at -48 VDC input input 5989 at -72 VDC input
Power supply output	—
Rated steady-state power	1600 W at -40 VDC to -72 VDC
Maximum peak power	1600 W at -40 VDC to -72 VDC

Support and other resources

Accessing Hewlett Packard Enterprise Support

- For live assistance, go to the Contact Hewlett Packard Enterprise Worldwide website:
<https://www.hpe.com/info/assistance>
- To access documentation and support services, go to the Hewlett Packard Enterprise Support Center website:
<https://www.hpe.com/support/hpesc>

Information to collect

- Technical support registration number (if applicable)
- Product name, model or version, and serial number
- Operating system name and version
- Firmware version
- Error messages
- Product-specific reports and logs
- Add-on products or components
- Third-party products or components

Accessing updates

- Some software products provide a mechanism for accessing software updates through the product interface. Review your product documentation to identify the recommended software update method.

- To download product updates:

Hewlett Packard Enterprise Support Center

<https://www.hpe.com/support/hpesc>

Hewlett Packard Enterprise Support Center: Software downloads

<https://www.hpe.com/support/downloads>

My HPE Software Center

<https://www.hpe.com/software/hpesoftwarecenter>

- To subscribe to eNewsletters and alerts:

<https://www.hpe.com/support/e-updates>

- To view and update your entitlements, and to link your contracts and warranties with your profile, go to the Hewlett Packard Enterprise Support Center More Information on Access to Support Materials page:

<https://www.hpe.com/support/AccessToSupportMaterials>

i IMPORTANT:

Access to some updates might require product entitlement when accessed through the Hewlett Packard Enterprise Support Center. You must have an HPE Passport set up with relevant entitlements.

Remote support

Remote support is available with supported devices as part of your warranty or contractual support agreement. It provides intelligent event diagnosis, and automatic, secure submission of hardware event notifications to Hewlett Packard Enterprise, which initiates a fast and accurate resolution based on the service level of your product. Hewlett Packard Enterprise strongly recommends that you register your device for remote support.

If your product includes additional remote support details, use search to locate that information.

HPE Get Connected

<https://www.hpe.com/services/getconnected>

HPE Pointnext Tech Care

<https://www.hpe.com/services/techcare>

HPE Datacenter Care

<https://www.hpe.com/services/datacentercare>

Warranty information

To view the warranty information for your product, see the links provided below:

HPE ProLiant and IA-32 Servers and Options

<https://www.hpe.com/support/ProLiantServers-Warranties>

HPE Enterprise and Cloudline Servers

<https://www.hpe.com/support/EnterpriseServers-Warranties>

HPE Storage Products

<https://www.hpe.com/support/Storage-Warranties>

HPE Networking Products

<https://www.hpe.com/support/Networking-Warranties>

Regulatory information

To view the regulatory information for your product, view the Safety and Compliance Information for Server, Storage, Power, Networking, and Rack Products, available at the Hewlett Packard Enterprise Support Center:

<https://www.hpe.com/support/Safety-Compliance-EnterpriseProducts>

Additional regulatory information

Hewlett Packard Enterprise is committed to providing our customers with information about the chemical substances in our products as needed to comply with legal requirements such as REACH (Regulation EC No 1907/2006 of the European Parliament and the Council). A chemical information report for this product can be found at:

<https://www.hpe.com/info/reach>

For Hewlett Packard Enterprise product environmental and safety information and compliance data, including RoHS and REACH, see:

<https://www.hpe.com/info/ecodata>

For Hewlett Packard Enterprise environmental information, including company programs, product recycling, and energy efficiency, see:

Documentation feedback

Hewlett Packard Enterprise is committed to providing documentation that meets your needs. To help us improve the documentation, use the Feedback button and icons (located at the bottom of an opened document) on the Hewlett Packard Enterprise Support Center portal (<https://support.hpe.com/hpesc>) to send any errors, suggestions, or comments. All document information is captured by the process.

