

# Dell Precision Rack 7910

## Owner's Manual



<b>1 Working on your computer</b> .....	<b>7</b>
Turning Off Your Computer.....	7
<b>2 LCD panel features</b> .....	<b>8</b>
Home screen.....	8
Setup menu.....	9
View menu.....	9
Documentation matrix.....	10
<b>3 Hard drive indicator codes</b> .....	<b>11</b>
<b>4 Installing and removing system components</b> .....	<b>13</b>
Safety instructions.....	13
Before working inside your system.....	13
After working inside your system.....	13
Recommended tools.....	13
System Overview.....	14
Front bezel (optional).....	16
Removing the front bezel.....	16
Installing the front bezel.....	16
Removing the system cover.....	17
Installing the system cover.....	17
Inside the system.....	18
Cooling shroud.....	19
Removing the cooling shroud.....	19
Installing the cooling shroud.....	19
System memory.....	20
General memory module installation guidelines.....	21
Sample memory configurations.....	21
Removing memory modules.....	24
Installing memory modules.....	25
Hard drives.....	27
Removing a 2.5 inch hard-drive blank.....	27
Installing a 2.5 inch hard-drive blank.....	28
Removing Hard Drive.....	28
Installing Hard Drive.....	29
Removing a hard drive from a hard-drive carrier.....	29
Installing a hard drive into a hard-drive carrier.....	30
Optical drive (optional).....	30
Removing the optical drive.....	30
Installing the optical drive.....	31
Cooling fans.....	31
Removing a cooling fan.....	31
Installing a cooling fan.....	32

Removing the cooling-fan assembly.....	33
Installing the cooling-fan assembly.....	34
Internal USB memory key (optional).....	35
Replacing the internal USB key.....	35
PCIe card holder.....	36
Removing the PCIe card holder.....	36
Installing the PCIe card holder.....	37
Opening and closing the PCIe card holder latch.....	38
Cable retention bracket.....	38
Removing the cable retention bracket.....	38
Installing the cable retention bracket.....	39
Expansion cards and expansion card risers.....	40
Expansion card installation guidelines.....	40
Removing an expansion card from expansion-card riser 2 or 3.....	40
Installing an expansion card into the expansion-card riser 2 or 3.....	41
Removing an expansion card from the expansion-card riser 1.....	42
Installing an expansion card into the expansion-card riser 1.....	43
Removing the riser 1 blank.....	44
Installing the riser 1 blank.....	45
Removing expansion-card risers.....	45
Installing expansion-card risers.....	49
GPU card installation guidelines.....	49
Installing a GPU card.....	50
Removing a GPU card.....	50
SD vFlash media card (optional).....	51
Replacing an SD vFlash media card.....	51
Internal dual SD module (optional).....	52
Removing an internal SD card.....	52
Installing an internal SD card.....	53
Removing the internal dual SD module .....	53
Installing the internal dual SD module .....	55
Integrated storage controller card.....	55
Removing the integrated storage controller card.....	55
Installing the integrated storage controller card.....	56
Network daughter card.....	57
Removing the network daughter card .....	57
Installing the network daughter card.....	58
Heat sink and processor.....	59
Removing a processor.....	59
Installing a processor.....	62
Power supply units.....	64
Hot spare feature.....	65
Removing the power supply unit blank.....	65
Installing the power supply unit blank.....	65
Removing an AC power supply unit.....	66
Installing an AC power supply unit.....	67
System battery.....	67
Replacing the system battery.....	67
Hard-drive backplane.....	69
Removing the hard-drive backplane .....	69

Installing the hard-drive backplane .....	71
Control panel assembly.....	72
Removing the control panel .....	72
Installing the control panel .....	73
System board.....	73
Removing the system board.....	73
Installing the system board.....	76
Entering the system service tag by using System Setup.....	77
Restoring the Service Tag by using the Easy Restore feature.....	77
Updating the BIOS version.....	77
Re-enabling the TPM for TXT users.....	77
<b>5 Troubleshooting your system.....</b>	<b>79</b>
Troubleshooting system startup failure.....	79
Troubleshooting external connections.....	79
Troubleshooting the video subsystem.....	79
Troubleshooting a USB device.....	80
Troubleshooting iDRAC Direct (USB XML configuration).....	80
Troubleshooting iDRAC Direct (laptop connection).....	80
Troubleshooting a serial I/O device.....	81
Troubleshooting a NIC.....	81
Troubleshooting a wet system.....	81
Troubleshooting a damaged system.....	82
Troubleshooting the system battery.....	82
Troubleshooting power supply units.....	82
Power source problems.....	83
Power supply unit problems.....	83
Troubleshooting cooling problems.....	83
Troubleshooting cooling fans.....	83
Troubleshooting system memory.....	84
Troubleshooting an internal USB key.....	84
Troubleshooting an SD card.....	85
Troubleshooting an optical drive.....	85
Troubleshooting a hard drive.....	86
Troubleshooting a storage controller.....	86
Troubleshooting expansion cards.....	87
Troubleshooting processors.....	87
Error Messages.....	87
System messages.....	88
Warning messages.....	88
Diagnostic messages.....	88
Alert messages.....	88
<b>6 Using system diagnostics.....</b>	<b>89</b>
Dell Embedded System Diagnostics.....	89
When to use the Embedded System Diagnostics.....	89
Running the Embedded System Diagnostics from Boot Manager.....	89
Running the Embedded System Diagnostics from the Dell Lifecycle Controller.....	89
System diagnostics controls.....	89

<b>7 Jumpers and connectors.....</b>	<b>91</b>
System board jumper settings.....	91
System board connectors.....	92
Disabling a forgotten password.....	93
<b>8 Specifications.....</b>	<b>95</b>
<b>9 System Setup.....</b>	<b>100</b>
Boot Menu.....	100
Timing Key Sequences.....	100
Dell Diagnostics.....	100
About system setup.....	101
Entering System Setup.....	101
System Setup Main Menu.....	101
System BIOS screen.....	101
System Information screen details.....	102
Memory Settings screen details.....	102
Processor Settings screen details.....	103
SATA Settings screen details.....	104
Boot Settings screen details.....	106
Integrated Devices screen details.....	107
Serial Communication screen details.....	109
System Profile Settings screen details.....	109
System Security settings screen details.....	110
Miscellaneous Settings screen details.....	112
<b>10 NIC indicator codes.....</b>	<b>113</b>
<b>11 Power indicator codes.....</b>	<b>114</b>
<b>12 Contacting Dell.....</b>	<b>116</b>
Contacting Dell.....	116
Quick Resource Locator (QRL).....	116

## Notes, cautions, and warnings

 **NOTE:** A NOTE indicates important information that helps you make better use of your computer.

 **CAUTION:** A CAUTION indicates either potential damage to hardware or loss of data and tells you how to avoid the problem.



 **WARNING:** A WARNING indicates a potential for property damage, personal injury, or death.

© 2018 - 2019 Dell Inc. or its subsidiaries. All rights reserved. Dell, EMC, and other trademarks are trademarks of Dell Inc. or its subsidiaries. Other trademarks may be trademarks of their respective owners.

# Working on your computer

## Turning Off Your Computer

 **CAUTION:** To avoid losing data, save and close all open files and exit all open programs before you turn off your computer.

1. Shut down the operating system:
  - In Windows 8:
    - Using a touch-enabled device:
      - a. Swipe in from the right edge of the screen, opening the Charms menu and select **Settings**.
      - b. Select the  and then select **Shut down**
    - Using a mouse:
      - a. Point to upper-right corner of the screen and click **Settings**.
      - b. Click the  and select **Shut down**.
  - In Windows 7:
    - a. Click **Start** .
    - b. Click **Shut Down**.
2. Ensure that the computer and all attached devices are turned off. If your computer and attached devices did not automatically turn off when you shut down your operating system, press and hold the power button for about 6 seconds to turn them off.

## LCD panel features

**NOTE:** The LCD panel is present only on Precision Rack 7910

The LCD panel of your system provides system information and status and error messages to indicate if the system is operating correctly or if the system needs attention. For more information on error messages, see the Dell Event and Error Messages Reference Guide at [dell.com/esmanuals](http://dell.com/esmanuals).

- The LCD backlight lights blue during normal operating conditions and lights amber to indicate an error condition.
- The LCD backlight is off when the system is in standby mode and can be turned on by pressing either the Select, Left, or Right button on the LCD panel.
- The LCD backlight remains off if LCD messaging is turned off through the iDRAC utility, the LCD panel, or other tools.

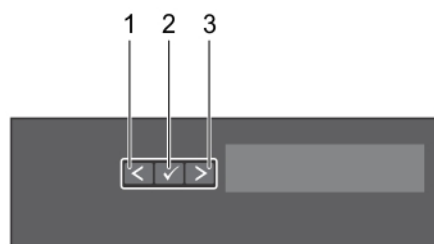

Figure 1. LCD panel features

Table 1. LCD panel features

Item	Button	Description
1	Left	Moves the cursor back in one-step increments.
2	Select	Selects the menu item highlighted by the cursor.
3	Right	Moves the cursor forward in one-step increments.
		During message scrolling:
		<ul style="list-style-type: none"> <li>• Press and hold the button to increase scrolling speed.</li> <li>• Release the button to stop.</li> </ul>



**NOTE:** The display will stop scrolling when the button is released. After 45 seconds of inactivity the display will start scrolling.

### Topics:

- [Home screen](#)
- [Setup menu](#)
- [View menu](#)
- [Documentation matrix](#)

## Home screen

The Home screen displays user-configurable information about the system. This screen is displayed during normal system operation when there are no status messages or errors. When the system is in standby mode, the LCD backlight turns off after five minutes of inactivity if there are no error messages. Press one of the three navigation buttons (Select, Left, or Right) to view the Home screen.

To navigate to the Home screen from another menu, continue to select the up arrow  until the Home icon  is displayed, and then select the Home icon.



From the Home screen, press the Select button to enter the main menu.

## Setup menu

**NOTE:** When you select an option in the Setup menu, you must confirm the option before proceeding to the next action.

Option	Description
<b>iDRAC</b>	Select <b>DHCP</b> or <b>Static IP</b> to configure the network mode. If <b>Static IP</b> is selected, the available fields are <b>IP</b> , <b>Subnet (Sub)</b> , and <b>Gateway (Gtw)</b> . Select <b>Setup DNS</b> to enable DNS and to view domain addresses. Two separate DNS entries are available.
<b>Set error</b>	Select <b>SEL</b> to view LCD error messages in a format that matches the IPMI description in the SEL. This is useful when trying to match an LCD message with an SEL entry.  Select <b>Simple</b> to view LCD error messages in a simplified user-friendly description. For more information about error messages, see the Dell Event and Error Messages Reference Guide at <a href="https://www.dell.com/openmanagemanuals">Dell.com/openmanagemanuals</a> > <b>OpenManage software</b> .
<b>Set home</b>	Select the default information to be displayed on the <b>Home</b> screen. See <a href="#">View menu</a> for the options and option items that can be set as the default on the <b>Home</b> screen.

## View menu

**NOTE:** When you select an option in the View menu, you must confirm the option before proceeding to the next action.

Option	Description
<b>iDRAC IP</b>	Displays the <b>IPv4</b> or <b>IPv6</b> addresses for iDRAC8. Addresses include <b>DNS (Primary and Secondary)</b> , <b>Gateway</b> , <b>IP</b> , and <b>Subnet</b> (IPv6 does not have Subnet).
<b>MAC</b>	Displays the MAC addresses for <b>iDRAC</b> , <b>iSCSI</b> , or <b>Network</b> devices.
<b>Name</b>	Displays the name of the <b>Host</b> , <b>Model</b> , or <b>User String</b> for the system.
<b>Number</b>	Displays the <b>Asset tag</b> or the <b>Service tag</b> for the system.
<b>Power</b>	Displays the power output of the system in BTU/hr or Watts. The display format can be configured in the <b>Set home</b> submenu of the <b>Setup</b> menu.
<b>Temperature</b>	Displays the temperature of the system in Celsius or Fahrenheit. The display format can be configured in the <b>Set home</b> submenu of the <b>Setup</b> menu.

Option	Description
<b>iDRAC IP</b>	Displays the IPv4 or IPv6 addresses for iDRAC8. Addresses include DNS(Primary and Secondary), Gateway, IP, and Subnet (IPv6 does not have Subnet).
<b>MAC</b>	Displays the MAC addresses for iDRAC, iSCSI, or Network devices.
<b>Name</b>	Displays the name of the Host, Model, or User String for the system.
<b>Number</b>	Displays the Asset tag or the Service tag for the system.
<b>Power</b>	Displays the power output of the system in BTU/hr or Watts. The display format can be configured in the Set home submenu of the Setup menu.
<b>Temperature</b>	Displays the temperature of the system in Celsius or Fahrenheit. The display format can be configured in the Set home submenu of the Setup menu.

# Documentation matrix

Table 2. Documentation matrix

To...	Refer to...
Install your system into a rack	Rack documentation included with your rack solution
Set up your system and know the system technical specifications	<i>Getting Started With Your System</i> that shipped with your system or see <a href="http://dell.com/poweredgemanuals">dell.com/poweredgemanuals</a>
Install the operating system	Operating system documentation at <a href="http://dell.com/operatingsystemmanuals">dell.com/operatingsystemmanuals</a>
Get an overview of the Dell Systems Management offerings	Dell OpenManage Systems Management Overview Guide at <a href="http://dell.com/openmanagemanuals">dell.com/openmanagemanuals</a>
Configure and log in to iDRAC, set up managed and management system, know the iDRAC features and troubleshoot using iDRAC	Integrated Dell Remote Access Controller User's Guide at <a href="http://dell.com/esmmanuals">dell.com/esmmanuals</a>
Know about the RACADM subcommands and supported RACADM interfaces	RACADM Command Line Reference Guide for iDRAC and CMC at <a href="http://dell.com/esmmanuals">dell.com/esmmanuals</a>
Launch, enable and disable Lifecycle Controller, know the features, use and troubleshoot Lifecycle Controller	Dell Lifecycle Controller User's Guide at <a href="http://dell.com/esmmanuals">dell.com/esmmanuals</a>
Use Lifecycle Controller Remote Services	Dell Lifecycle Controller Remote Services Quick Start Guide at <a href="http://dell.com/esmmanuals">dell.com/esmmanuals</a>
Set up, use, and troubleshoot OpenManage Server Administrator	Dell OpenManage Server Administrator User's Guide at <a href="http://dell.com/openmanagemanuals">dell.com/openmanagemanuals</a>
Install, use and troubleshoot OpenManage Essentials	Dell OpenManage Essentials User's Guide at <a href="http://dell.com/openmanagemanuals">dell.com/openmanagemanuals</a>
Know the features of the storage controller cards, deploy the cards, and manage the storage subsystem	Storage controller documentation at <a href="http://dell.com/storagecontrollermanuals">dell.com/storagecontrollermanuals</a>
Check the event and error messages generated by the system firmware and agents that monitor system components	Dell Event and Error Messages Reference Guide at <a href="http://dell.com/esmmanuals">dell.com/esmmanuals</a>
Know about Alert messages	Dell OpenManage Systems Management Overview Guide at <a href="http://dell.com/openmanagemanuals">dell.com/openmanagemanuals</a>
Know about iDRAC 8 User's Manual	<a href="http://www.dell.com/support/home/us/en/19/product-support/product/integrated-dell-remote-access-cntrlr-8-with-lifecycle-controller-v2.00.00.00/manuals">http://www.dell.com/support/home/us/en/19/product-support/product/integrated-dell-remote-access-cntrlr-8-with-lifecycle-controller-v2.00.00.00/manuals</a>

## Hard drive indicator codes

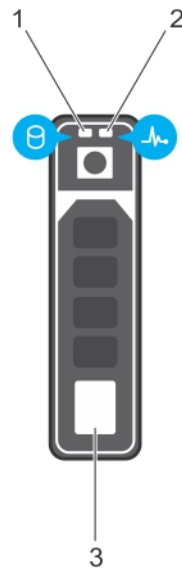

**Figure 2. Hard drive indicators**

1. hard drive activity indicator
2. hard drive status indicator
3. hard drive

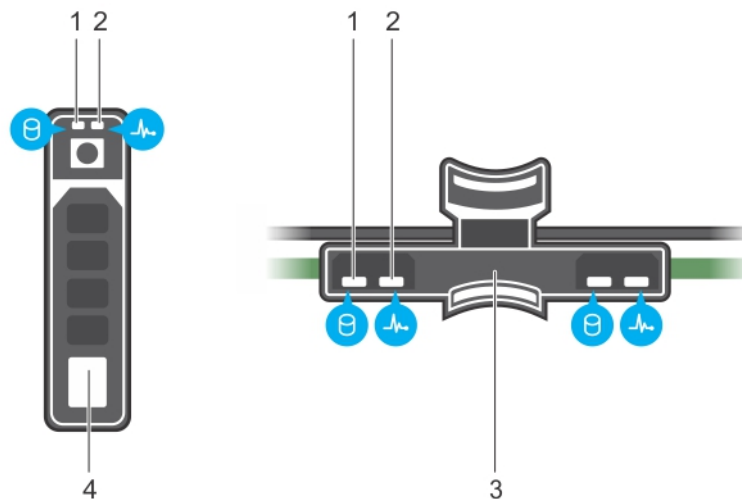

**Figure 3. Hard drive indicators on the hard drive and the hard drive tray backplane**

- |  |                                |
|--|--------------------------------|
| 1. hard drive activity indicator           | 2. hard drive status indicator |
| 3. hard drive backplane on hard drive tray | 4. hard drive                  |

**NOTE:** If the hard drive is in Advanced Host Controller Interface (AHCI) mode, the status indicator (on the right side) does not function and remains off.

**Table 3. Hard drive indicator codes**

<b>Drive-status indicator pattern (RAID only)</b>	<b>Condition</b>
Blinks green two times per second	Identifying drive or preparing for removal.
Off	Drive ready for insertion or removal. <b>NOTE:</b> The drive status indicator remains off until all hard drives are initialized after the system is turned on. Drives are not ready for insertion or removal during this time.
Blinks green, amber, and turns off	Predicted drive failure
Blinks amber four times per second	Drive failed
Blinks green slowly	Drive rebuilding
Steady green	Drive online
Blinks green three seconds, amber three seconds, and turns off six seconds	Rebuild aborted

# Installing and removing system components

## Safety instructions

- NOTE:** Whenever you need to lift the system, get others to assist you. To avoid injury, do not attempt to lift the system by yourself.
- WARNING:** Opening or removing the system cover when the system is on may expose you to a risk of electric shock.
- CAUTION:** Do not operate the system without the cover for a duration exceeding five minutes.
- CAUTION:** Many repairs may only be done by a certified service technician. You should only perform troubleshooting and simple repairs as authorized in your product documentation, or as directed by the online or telephone service and support team. Damage due to servicing that is not authorized by Dell is not covered by your warranty. Read and follow the safety instructions that came with the product.
- NOTE:** Dell recommends that you always use a static mat and static strap while working on components inside the system.
- NOTE:** To ensure proper operation and cooling, all bays in the system must be populated at all times with either a module or with a blank.

## Before working inside your system

1. Turn off the system, including any attached peripherals.
2. Disconnect the system from the electrical outlet and disconnect the peripherals.
3. Remove the system cover.

## After working inside your system

1. Install the system cover.
2. Reconnect the system to its electrical outlet.
3. Turn the system on, including any attached peripherals.

## Recommended tools

You need the following tools to perform the removal and installation procedures:

- Key to the bezel lock. This is only required when you have a bezel.
- #2 Phillips screwdriver

For how-to videos, documentation, and troubleshooting solutions, scan this QR code, or click here: <http://www.Dell.com/QRL/>



Workstation/R7910

# System Overview

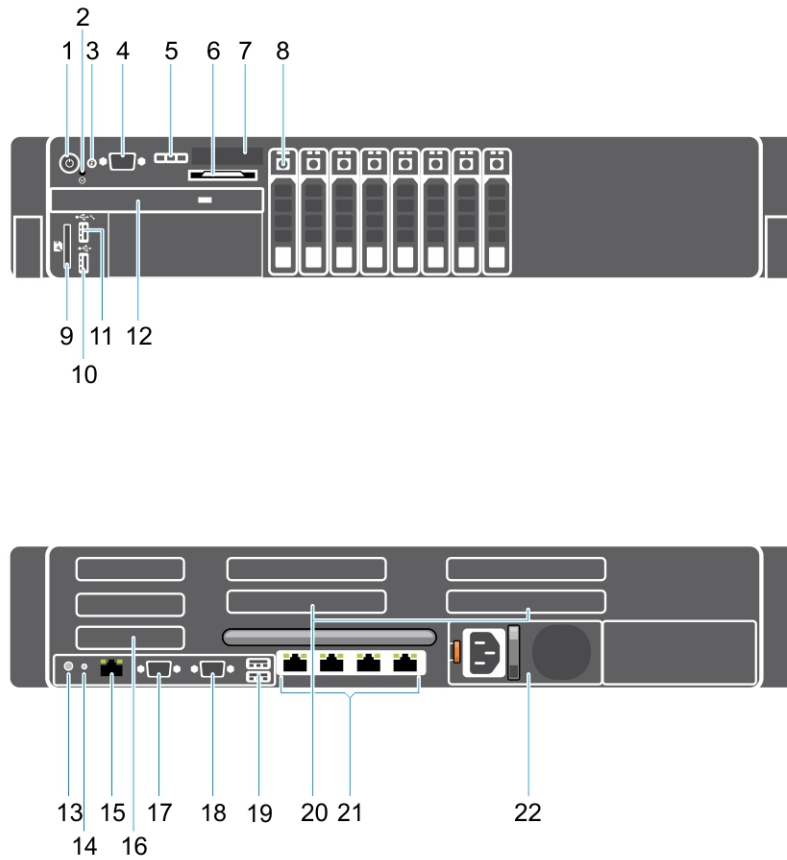











Figure 4. Front and Back View

Table 4. Features and indicators of Precision 7910.

Item	Indicator, Button, or Connector	Icon	Description
1	Power-on indicator, power button		<p>The power-on indicator lights when the system power is on. The power button controls the power supply output to the system.</p> <p><b>NOTE: On ACPI-compliant operating systems, turning off the system using the power button causes the system to perform a graceful shutdown before power to the system is turned off.</b></p>
2	NMI button		<p>Used to troubleshoot software and device driver errors when running certain operating systems. This button can be pressed using the end of a paper clip.</p> <p>Use this button only if directed to do so by qualified support personnel or by the operating system documentation.</p>
3	System identification button		<p>The identification buttons on the front and back panels can be used to locate a particular system within a rack. When one of these buttons is pressed, the LCD panel on the front and the system status indicator on the back flashes until one of the buttons is pressed again.</p> <p>Press to toggle the system ID on and off.</p> <p>If the system stops responding during POST, press and hold the system ID button for more than five seconds to enter BIOS progress mode.</p>

Item	Indicator, Button, or Connector	Icon	Description
			To reset iDRAC (if not disabled in F2 iDRAC setup) press and hold the button for more than 15 seconds.
4	Video connector		Allows you to connect a VGA display to the system.
5	LCD menu buttons		Allow you to navigate the control panel LCD menu.
6	Information tag		A slide-out label panel which allows you to record system information such as Service Tag, NIC, MAC address and so on as per your need.
7	LCD panel		Displays system ID, status information, and system error messages. The LCD lights blue during normal system operation. The LCD lights amber when the system needs attention, and the LCD panel displays an error code followed by descriptive text. <b>NOTE: If the system is connected to a power source and an error is detected, the LCD lights amber regardless of whether the system is turned on or off.</b>
8	Hard drives		Up to eight 2.5 inch drives.
9	vFlash media card slot		Allows you to insert a vFlash media card.
10	USB connector		Allows you to connect USB devices to the system. The ports are USB 2.0-compliant.
11	USB management port/iDRAC Direct		Enables you to connect USB devices to the system or provides access to the iDRAC Direct features. For more information, see the Integrated Dell Remote Access Controller User's Guide at <b>Dell.com/idracmanuals</b> . The USB management port is USB 2.0-compliant.
12	Optical drive (optional)		One optional SATA DVD-ROM drive or DVD+/-RW drive.
13	System identification button		The identification buttons on the front and back panels can be used to locate a particular system within a rack. <b>Precision Rack 7910</b> When one of these buttons is pressed, the LCD panel on the front and the system status indicator on the back flashes until one of the buttons is pressed again. Press to toggle the system ID on and off. If the system stops responding during POST, press and hold the system ID button for more than five seconds to enter BIOS progress mode. To reset iDRAC (if not disabled in F2 iDRAC setup) press and hold the button for more than 15 seconds.
14	System identification connector		Connects the optional system status indicator assembly through the optional cable management arm.
15	iDRAC8 Enterprise port		Dedicated management port.
16	Half-height PCIe expansion-card slot (3)		Allows you to connect up to three half-height PCI Express expansion cards.
17	Serial connector		Allows you to connect a serial device to the system.
18	Video connector		Allows you to connect a VGA display to the system.
19	USB connector (2)		Allows you to connect USB devices to the system. The ports are USB 2.0-compliant.

Item	Indicator, Button, or Connector	Icon	Description
20	Full-height PCIe expansion card slot (4)		Allows you to connect up to four single wall or two double wide PCI Express expansion cards.
21	Ethernet connector (4)		Four integrated 10/100/1000 Mbps NIC connectors or Four integrated connectors that include: <ul style="list-style-type: none"> <li>• Two 10/100/1000 Mbps NIC connectors</li> <li>• Two 100 Mbps/1 Gbps/10 Gbps NIC connectors</li> </ul>
22	Power supply unit		<b>AC</b> 1100 W

## Front bezel (optional)

### Removing the front bezel

1. Unlock the bezel lock at the left end of the bezel.
2. Lift the release latch next to the bezel lock.
3. Pull the left end of the bezel, unhook the right end and remove the bezel.

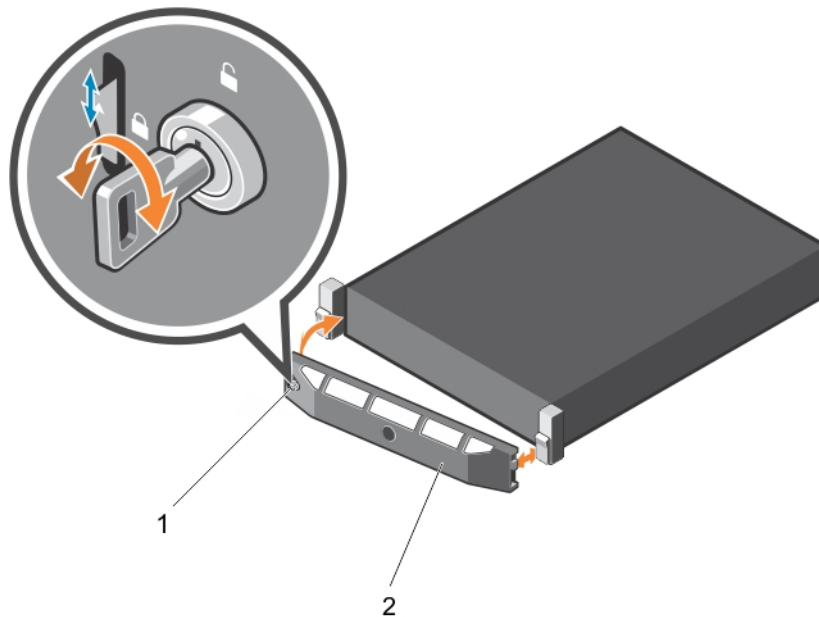

**Figure 5. Removing and installing the front bezel**

- a. bezel lock
- b. front bezel

### Installing the front bezel

1. Hook the right end of the bezel onto the chassis.
2. Fit the free end of the bezel onto the system.
3. Secure the bezel with the keylock.



# Removing the system cover

1. Ensure that you read the [Safety instructions](#).
2. Turn off the system, including any attached peripherals.
3. Disconnect the system from the electrical outlet and peripherals.
4. Rotate the latch release lock counter clockwise to the unlocked position.
5. Lift the latch and rotate the latch toward the back of the system.
6. Hold the cover on both sides, and lift the cover away from the system.

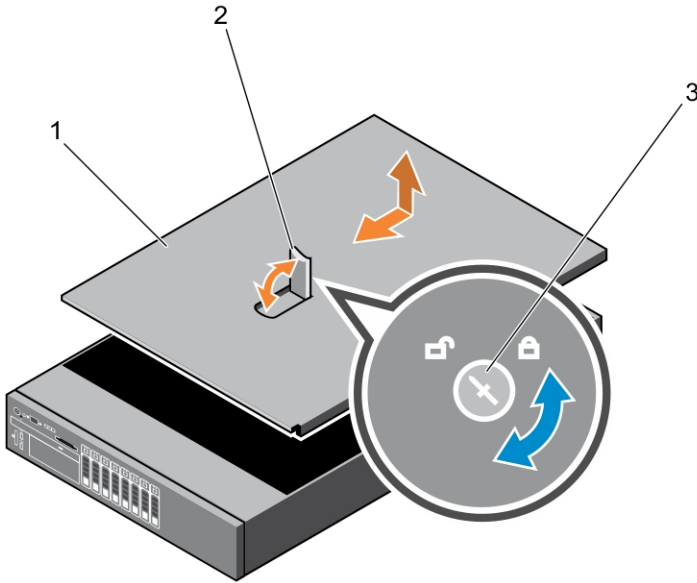

1. system cover
2. latch
3. latch release lock

To see a video on removing and installing System Cover, scan this QR code, or click here: <http://www.Dell.com/QRL/Workstation/>



R7910/Cover

# Installing the system cover

Ensure that you read the [Safety Instructions](#).

To see a video on removing and installing System Cover, scan this QR code, or click here: <http://www.Dell.com/QRL/Workstation/>



R7910/Cover

1. Align the slots of the system cover with the tabs on the chassis.

2. Press the cover release latch, and push the cover toward the front of the chassis until the latch locks into place.
3. Turn the latch release lock clockwise to the locked position.
4. Install the optional bezel.
5. Reconnect the system to its electrical outlet and turn the system on, including any attached peripherals.

## Inside the system

**CAUTION:** Many repairs may only be done by a certified service technician. You should only perform troubleshooting and simple repairs as authorized in your product documentation, or as directed by the online or telephone service and support team. Damage due to servicing that is not authorized by Dell is not covered by your warranty. Read and follow the safety instructions that came with the product.

Figure 6. Inside the system—Precision Rack 7910

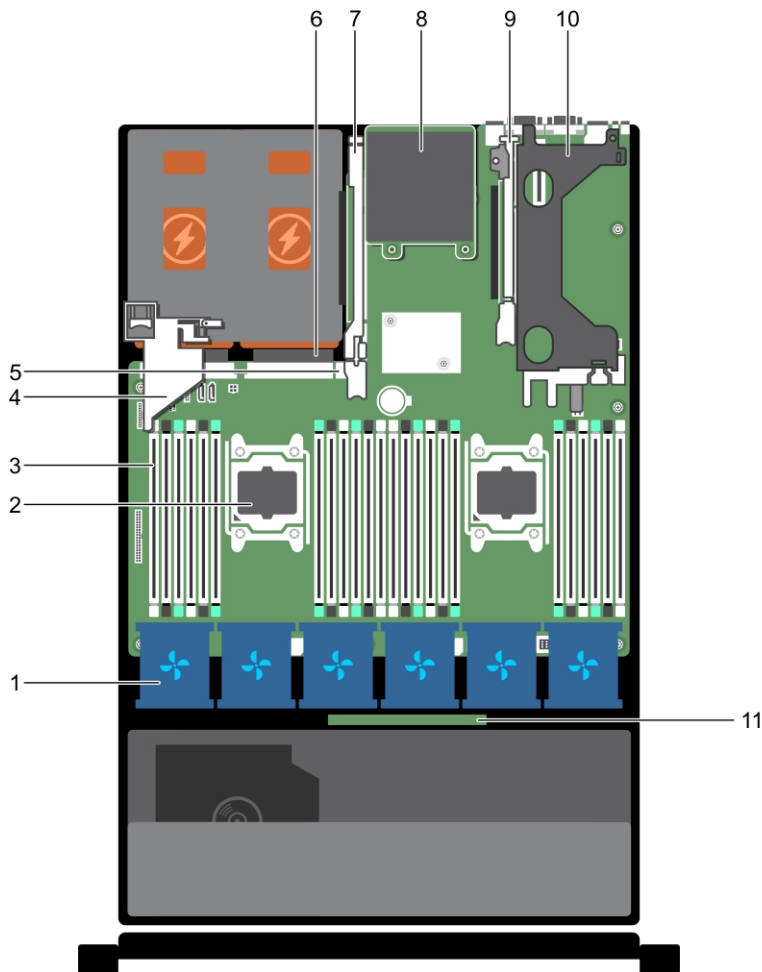

1. cooling-fan (6)
2. processor (2)
3. DIMM (24)
4. PCIe card holder
5. internal USB port
6. power supply unit (2)
7. expansion-card riser (3)
8. network daughter card
9. expansion-card riser (2)
10. expansion-card riser (1)
11. hard-drive backplane

# Cooling shroud

## Removing the cooling shroud

**CAUTION:** Many repairs may only be done by a certified service technician. You should only perform troubleshooting and simple repairs as authorized in your product documentation, or as directed by the online or telephone service and support team. Damage due to servicing that is not authorized by Dell is not covered by your warranty. Read and follow the safety instructions that came with the product.

1. Ensure that you read the [Safety instructions](#).
2. Follow the procedure listed in [Before working inside your system](#).
3. If installed, remove the full-length PCIe cards.

**CAUTION:** Never operate your system with the cooling shroud removed. The system may get overheated quickly, resulting in shutdown of the system and loss of data.

Hold the shroud and lift it away from the system.

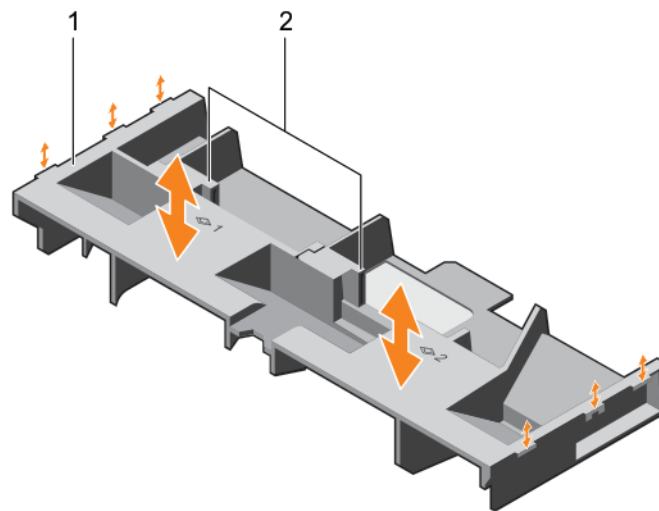

**Figure 7. Removing and installing the cooling shroud**

- a. cooling shroud
  - b. touch point (2)
1. Replace the cooling shroud. See [Installing the cooling shroud](#)
  2. Follow the procedure listed in [After working inside your system](#).

## Installing the cooling shroud

**CAUTION:** Many repairs may only be done by a certified service technician. You should only perform troubleshooting and simple repairs as authorized in your product documentation, or as directed by the online or telephone service and support team. Damage due to servicing that is not authorized by Dell is not covered by your warranty. Read and follow the safety instructions that came with the product.

1. Ensure that you read the [Safety instructions](#).
2. Align the tabs on the cooling shroud with the securing slots on the chassis.
3. Lower the cooling shroud into the chassis until it is firmly seated.
4. Follow the procedure listed in [After working inside your system](#).

# System memory

Your system supports DDR4 registered DIMMs (RDIMMs), and load reduced DIMMs (LRDIMMs).

**NOTE:** MT/s indicates DIMM speed in MegaTransfers per second.

Memory bus operating frequency can be 1866 MT/s, or 2133 MT/s depending on the following factors:

- DIMM type (RDIMM or LRDIMM)
- Number of DIMMs populated per channel
- System profile selected (for example, Performance Optimized, Custom, or Dense Configuration Optimized)
- Maximum supported DIMM frequency of the processors

The system contains 24 memory sockets split into two sets of 12 sockets, one set per processor. Each 12-socket set is organized into four channels. In each channel, the release levers of the first socket are marked white, the second socket black, and the third socket green.

**NOTE:** DIMMs in sockets A1 to A12 are assigned to processor 1 and DIMMs in sockets B1 to B12 are assigned to processor 2.

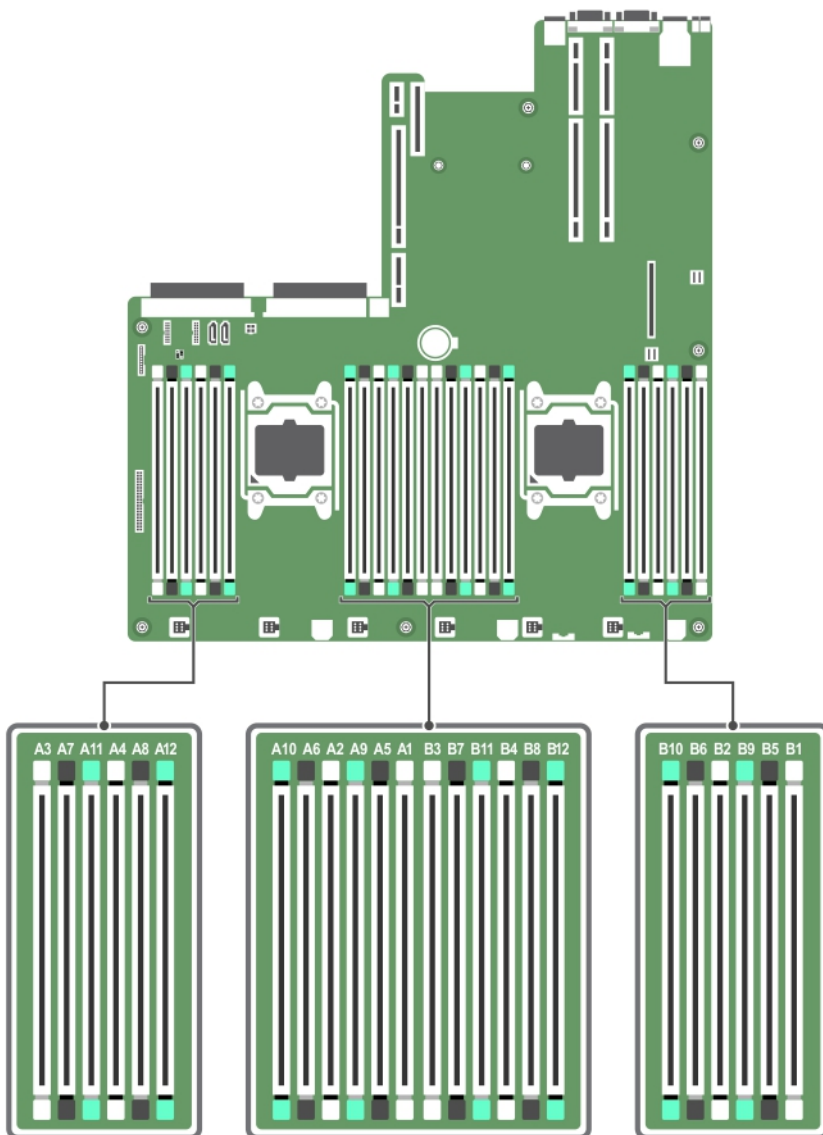

Memory channels are organized as follows:

- Processor 1**
- channel 0: slots A1, A5, and A9
  - channel 1: slots A2, A6, and A10
  - channel 2: slots A3, A7, and A11

	channel 3: slots A4, A8, and A12
<b>Processor 2</b>	channel 0: slots B1, B5, and B9
	channel 1: slots B2, B6, and B10
	channel 2: slots B3, B7, and B11
	channel 3: slots B4, B8, and B12

**Table 5. Memory population**

DIMM Type	DIMMs Populated/ Channel	Operating Frequency (in MT/s)	Maximum DIMM Rank/Channel
RDIMM	1	2133, 1866, 1600, 1333	Dual rank or single rank
	2	2133, 1866, 1600, 1333	Dual rank or single rank
	3	1866, 1600, 1333	Dual rank or single rank
LRDIMM	1	2133, 1866, 1600, 1333	Quad rank
	2	2133, 1866, 1600, 1333	Quad rank
	3	1866, 1600, 1333	Quad rank

## General memory module installation guidelines

This system supports Flexible Memory Configuration, enabling the system to be configured and run in any valid chipset architectural configuration. The following are the recommended guidelines for installing memory modules:

- RDIMMs and LRDIMMs must not be mixed.
- x4 and x8 DRAM based DIMMs can be mixed.
- Up to three dual- or single-rank RDIMMs can be populated per channel.
- Up to three LRDIMMs can be populated per channel regardless of rank count.
- Populate DIMM sockets only if a processor is installed. For single-processor systems, sockets A1 to A12 are available. For dual-processor systems, sockets A1 to A12 and sockets B1 to B12 are available.
- Populate all sockets with white release tabs first, then black, and then green.
- Populate the sockets by highest rank count in the following order — first in sockets with white release levers, then black, and then green. For example, if you want to mix single-rank and dual-rank DIMMs, populate dual-rank DIMMs in the sockets with white release tabs and single-rank DIMMs in the sockets with black release tabs.
- When mixing memory modules with different capacities, populate the sockets with memory modules with highest capacity first. For example, if you want to mix 4 GB and 8 GB DIMMs, populate 8 GB DIMMs in the sockets with white release tabs and 4 GB DIMMs in the sockets with black release tabs.
- In a dual-processor configuration, the memory configuration for each processor should be identical. For example, if you populate socket A1 for processor 1, then populate socket B1 for processor 2, and so on.
- Memory modules of different capacities can be mixed provided other memory population rules are followed (for example, 4 GB and 8 GB memory modules can be mixed).
- Mixing of more than two DIMM capacities in a system is not supported.
- Populate four DIMMs per processor (one DIMM per channel) at a time to maximize performance.

## Sample memory configurations

The following tables show sample memory configurations for one and two processor configurations that follow the appropriate memory guidelines.

**NOTE:** 1R, 2R, and 4R in the following tables indicate single, dual, and quad-rank DIMMs respectively.

**Table 6. Memory configurations—single processor**

System capacity (in GB)	DIMM size (in GB)	Number of DIMMs	DIMM rank, organization, and frequency	DIMM slot population
4	4	1	1R, x8, 2133 MT/s,	A1

System capacity (in GB)	DIMM size (in GB)	Number of DIMMs	DIMM rank, organization, and frequency	DIMM slot population
			1R, x8, 1866 MT/s	
8	4	2	1R, x8, 2133 MT/s, 1R, x8, 1866 MT/s	A1, A2
16	4	4	1R, x8, 2133 MT/s, 1R, x8, 1866 MT/s	A1, A2, A3, A4
	8	2	2R, x8, 2133 MT/s, 2R, x8, 1866 MT/s	A1, A2
24	4	6	1R, x8, 2133 MT/s, 1R, x8, 1866 MT/s	A1, A2, A3, A4, A5, A6
48	4	12	1R, x8, 1866 MT/s, 1R, x8, 1600 MT/s	A1, A2, A3, A4, A5, A6, A7, A8, A9, A10, A11, A12
	8	6	2R, x8, 2133 MT/s, 2R, x8, 1866 MT/s	A1, A2, A3, A4, A5, A6
96	8	12	2R, x8, 1866 MT/s, 2R, x8 1600 MT/s	A1, A2, A3, A4, A5, A6, A7, A8, A9, A10, A11, A12
	16	6	2R, x4, 2133 MT/s, 2R, x4, 1866 MT/s	A1, A2, A3, A4, A5, A6
128	16	8	2R, x4, 2133 MT/s, 2R, x4, 1866 MT/s,	A1, A2, A3, A4, A5, A6, A7, A8
144	16 and 8	10	2R, x4 and 2R, x8, 1866 MT/s 2R, x4 and 2R, x8, 1600 MT/s	A1, A2, A3, A4, A5, A6, A7, A8, A9, A11
				<b>NOTE: 16 GB DIMMs must be installed in slots numbered A1, A2, A3, A4, A5, A6, A7, and A8 and 8 GB DIMMs must be installed in slots A9 and A11.</b>
256	32	8	LRDIMM, x4, 1866 MT/s LRDIMM, 4R, 2133 MT/s RDIMM, 2R, 2133 MT/s	A1, A2, A3, A4, A5, A6, A7, A8
384	32	12	LRDIMM, x4, 1866 MT/s LRDIMM, x4, 1600 MT/s LRDIMM, 4R, 1866 MT/s RDIMM, 2R, 1866 MT/s	A1, A2, A3, A4, A5, A6, A7, A8, A9, A10, A11, A12
512	64	8	LRDIMM, x4, 2133 MT/s LRDIMM, 4R, 2133 MT/s	A1, A2, A3, A4, A5, A6, A7, A8
768	64	12	LRDIMM, x4, 1866 MT/s LRDIMM, 4R, 1866 MT/s	A1, A2, A3, A4, A5, A6, A7, A8, A9, A10, A11, A12

**Table 7. Memory configurations—two processors**

System capacity (in GB)	DIMM size (in GB)	Number of DIMMs	DIMM rank, organization, and frequency	DIMM slot population
16	4	4	1R, x8, 2133 MT/s, 1R, x8, 1866 MT/s	A1, A2, B1, B2
32	4	8	1R, x8, 2133 MT/s, 1R, x8, 1866 MT/s	A1, A2, A3, A4, B1, B2, B3, B4
64	4	16	1R, x8, 2133 MT/s 1R, x8, 1866 MT/s	A1, A2, A3, A4, A5, A6, A7, A8, B1, B2, B3, B4, B5, B6, B7, B8
	8	8	2R, x8, 2133 MT/s, 2R, x8, 1866 MT/s	A1, A2, A3, A4, B1, B2, B3, B4
96	4	24	1R, x8, 1866 MT/s 1R, x8, 1600 MT/s	A1, A2, A3, A4, A5, A6, A7, A8, A9, A10, A11, A12, B1, B2, B3, B4, B5, B6, B7, B8, B9, B10, B11, B12
	8	12	2R, x8, 2133 MT/s, 2R, x8, 1866 MT/s	A1, A2, A3, A4, A5, A6, B1, B2, B3, B4, B5, B6
128	8	16	2R, x8, 2133 MT/s 2R, x8, 1866 MT/s	A1, A2, A3, A4, A5, A6, A7, A8, B1, B2, B3, B4, B5, B6, B7, B8
	16	8	2R, x4, 2133 MT/s, 2R, x4, 1866 MT/s	A1, A2, A3, A4, B1, B2, B3, B4
160	8	20	2R, x8, 1866 MT/s 2R, x8, 1600 MT/s	A1, A2, A3, A4, A5, A6, A7, A8, A9, A11, B1, B2, B3, B4, B5, B6, B7, B8, B9, B11
	16 and 8	12	2R, x4, 2133 MT/s, 2R, x8, 2133 MT/s, 2R, x4, 1866 MT/s, 2R, x8, 1866 MT/s	A1, A2, A3, A4, A5, A6, B1, B2, B3, B4, B5, B6
			<b>NOTE: 16 GB DIMMs must be installed in slots numbered A1, A2, A3, A4, B1, B2, B3, and B4 and 8 GB DIMMs must be installed in slots A5, A6, B5, and B6.</b>	
192	8	24	2R, x8, 1866 MT/s 2R, x8, 1600 MT/s	A1, A2, A3, A4, A5, A6, A7, A8, A9, A10, A11, A12, B1, B2, B3, B4, B5, B6, B7, B8, B9, B10, B11, B12
	16	12	2R, x4, 2133 MT/s, 2R, x4, 1866 MT/s	A1, A2, A3, A4, A5, A6, B1, B2, B3, B4, B5, B6
256	16	16	2R, x4, 2133 MT/s, 2R, x4, 1866 MT/s,	A1, A2, A3, A4, A5, A6, A7, A8, B1, B2, B3, B4, B5, B6, B7, B8
384	16	24	2R, x4, 1866 MT/s, 2R, x4, 1600 MT/s,	A1, A2, A3, A4, A5, A6, A7, A8, A9, A10, A11, A12, B1, B2, B3, B4, B5, B6, B7, B8, B9, B10, B11, B12
	32	12	LRDIMM, 4R, x4, 2133 MT/s RDIMM, 2R, x4, 2133 MT/s	A1, A2, A3, A4, A5, A6, B1, B2, B3, B4, B5, B6

System capacity (in GB)	DIMM size (in GB)	Number of DIMMs	DIMM rank, organization, and frequency	DIMM slot population
				A1, A2, A3, A4, A5, A6, B1, B2, B3, B4, B5, B6
512	32	16	LRDIMM, 4R, x4, 2133 MT/s RDIMM, 4R, x4, 2133 MT/s	A1, A2, A3, A4, A5, A6, A7, A8, B1, B2, B3, B4, B5, B6, B7, B8 A1, A2, A3, A4, A5, A6, A7, A8, B1, B2, B3, B4, B5, B6, B7, B8
	64	8	LRDIMM, 4R, x4, 2133 MT/s	A1, A2, A3, A4, B1, B2, B3, B4
768	32	24	LRDIMM, 4R, x4, 1866 MT/s LRDIMM, 4R, x4, 1600 MT/s RDIMM, 2R, x4, 1866 MT/s	A1, A2, A3, A4, A5, A6, A7, A8, A9, A10, A11, A12, B1, B2, B3, B4, B5, B6, B7, B8, B9, B10, B11, B12
	64	12	LRDIMM, 4R, x4, 2133 MT/s	A1, A2, A3, A4, A5, A6, A7, A8, A9, A10, A11, A12, B1, B2, B3, B4, B5, B6
1536	64	24	LRDIMM, 4R, x4, 1866 MT/s	A1, A2, A3, A4, A5, A6, A7, A8, A9, A10, A11, A12, B1, B2, B3, B4, B5, B6, B7, B8, B9, B10, B11, B12

## Removing memory modules

**CAUTION:** Many repairs may only be done by a certified service technician. You should only perform troubleshooting and simple repairs as authorized in your product documentation, or as directed by the online or telephone service and support team. Damage due to servicing that is not authorized by Dell is not covered by your warranty. Read and follow the safety instructions that came with the product.

1. Ensure that you read the [Safety instructions](#).
2. Follow the procedure listed in [Before working inside your system](#).
3. Remove the cooling shroud.

**NOTE:** The memory modules are hot to touch for some time after the system has been powered down. Allow the memory modules to cool before handling them. Handle the memory modules by the card edges and avoid touching the components or metallic contacts on the memory module.

**CAUTION:** To ensure proper system cooling, memory-module blanks must be installed in any memory socket that is not occupied. Remove memory-module blanks only if you intend to install memory modules in those sockets.

1. Locate the appropriate memory module socket.

**CAUTION:** Handle each memory module only by the card edges, making sure not to touch the middle of the memory module or metallic contacts.

2. To release the memory module from the socket, simultaneously press the ejectors on both ends of the memory-module socket.



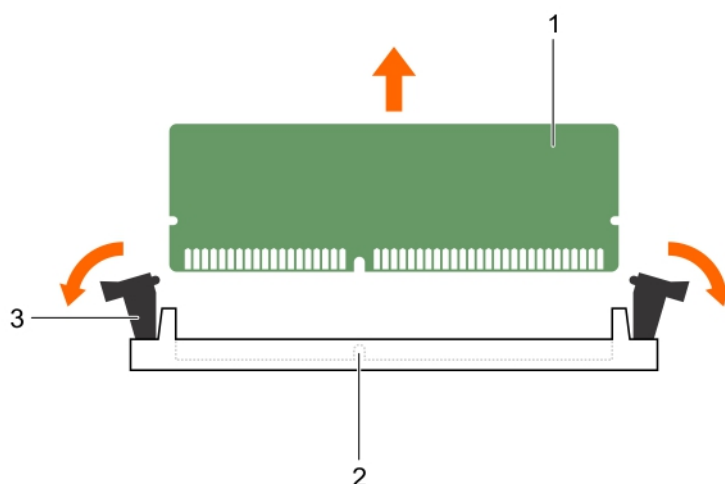

**Figure 8. Removing memory module**

- a. memory-module
- b. memory-module socket
- c. memory module socket ejector (2)

To see a video on removing and installing memory module, scan this QR code, or click here: <http://www.Dell.com/QRL/Workstation/>



R7910/DIMMs

## Installing memory modules

**CAUTION:** Many repairs may only be done by a certified service technician. You should only perform troubleshooting and simple repairs as authorized in your product documentation, or as directed by the online or telephone service and support team. Damage due to servicing that is not authorized by Dell is not covered by your warranty. Read and follow the safety instructions that came with the product.

1. Ensure that you read the [Safety instructions](#).
2. Follow the procedure listed in [After working inside your system](#).
3. Remove the cooling shroud.
4. Removing the cooling fan assembly.

**NOTE:** The memory modules are hot to touch for some time after the system has been powered down. Allow the memory modules to cool before handling them. Handle the memory modules by the card edges and avoid touching the components or metallic contacts on the memory module.

**CAUTION:** To ensure proper system cooling, memory-module blanks must be installed in any memory socket that is not occupied. Remove memory-module blanks only if you intend to install memory modules in those sockets.

1. Locate the appropriate memory-module socket.

**CAUTION:** Handle each memory module only by the card edges, making sure not to touch the middle of the memory module or metallic contacts.

2. If installed, remove the cooling fan assembly. For more information, see Removing the cooling-fan assembly.
3. If a memory module or a memory-module blank is installed in the socket, remove it.

**NOTE:** Retain the removed memory-module blank(s) for future use.

**CAUTION:** To prevent damage to the memory module or the memory-module socket during installation, do not bend or flex the memory module; insert both ends of the memory module simultaneously.

4. Align the edge connector of the memory module with the alignment key of the memory module socket, and insert the memory module in the socket.

**NOTE:** The memory-module socket has an alignment key that allows you to install the memory module in the socket in only one orientation.

**CAUTION:** Do not apply pressure at the center of the memory module; apply pressure at both ends of the memory module evenly.

5. Press the memory module with your thumbs until the socket levers firmly click into place.

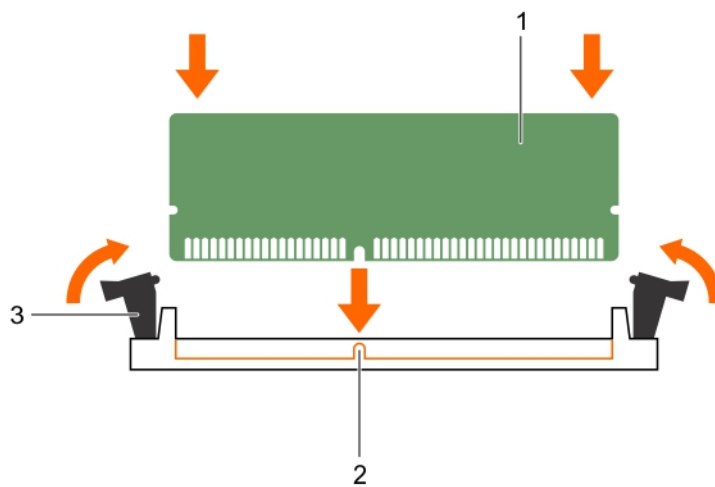

**Figure 9. Installing the memory module**

- a. memory module
- b. alignment key
- c. memory-module socket ejector (2)

When the memory module is properly seated in the socket, the levers on the memory module socket align with the levers on the other sockets that have memory modules installed.

6. Repeat steps 4 and 5 of this procedure to install the remaining memory modules.

1. Install the cooling shroud.
2. Follow the procedure listed in After working inside your system .
3. Press <F2> to enter **System Setup**, and check the **System Memory** setting.

The system should have already changed the value to reflect the installed memory.

4. If the value is incorrect, one or more of the memory modules may not be installed properly. Repeat step 4 through step 7 of this procedure, checking to ensure that the memory modules are firmly seated in their sockets.
5. Run the system memory test in the system diagnostics.

To see a video on how to remove & install memory, scan this QR code, or click here: <http://www.Dell.com/QRL/Workstation/R7910/>



DIMMs

## Hard drives

Your system supports Client and Enterprise-class hard drives, which are designed for 24x7 operating environment. Selecting the correct drive class will enable the critical areas of quality, functionality, performance, and reliability to be optimized for the target implementation.

Due to industry advances, in some cases, the larger capacity drives have been changed to a larger sector size. The larger sector size can have impacts on operating systems and applications.

All hard drives are connected to the system board through the hard-drive backplane. Hard drives are supplied in hard-drive carriers that fit in the hard-drive slots.

**CAUTION:** Before attempting to remove or install a hard drive while the system is running, see the documentation for the storage controller card to ensure that the host adapter is configured correctly to support hard drive removal and insertion.

**CAUTION:** Do not turn off or reboot your system while the hard drive is being formatted. Doing so can cause a hard drive failure.

Use only hard drives that have been tested and approved for use with the hard-drive backplane.

When you format a hard drive, allow enough time for the formatting to be completed. Be aware that high-capacity hard drives can take a number of hours to format.

## Removing a 2.5 inch hard-drive blank

**CAUTION:** Many repairs may only be done by a certified service technician. You should only perform troubleshooting and simple repairs as authorized in your product documentation, or as directed by the online or telephone service and support team. Damage due to servicing that is not authorized by Dell is not covered by your warranty. Read and follow the safety instructions that came with the product.

**CAUTION:** To maintain proper system cooling, all empty hard-drive slots must have hard-drive blanks installed.

1. Ensure that you read the [Safety instructions](#).
2. If installed, remove the bezel.
3. Press the release button and slide the hard-drive blank out of the hard-drive slot.

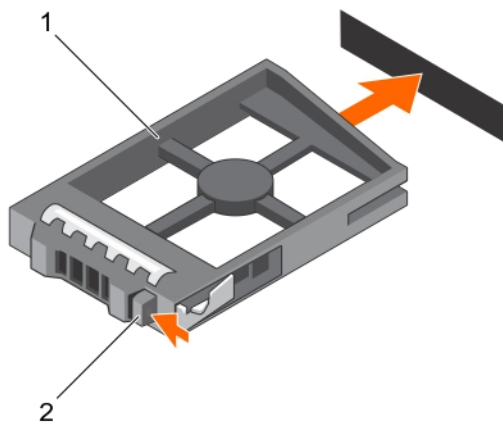

**Figure 10. Removing and installing a 2.5 inch hard-drive blank**

- a. hard-drive blank
- b. release button

## Installing a 2.5 inch hard-drive blank

1. Ensure that you read the [Safety instructions](#).
2. If installed, remove the front bezel.
3. Insert the hard-drive blank into the hard-drive slot until the release button clicks into place.
4. If applicable, install the front bezel.

## Removing Hard Drive

**CAUTION:** Many repairs may only be done by a certified service technician. You should only perform troubleshooting and simple repairs as authorized in your product documentation, or as directed by the online or telephone service and support team. Damage due to servicing that is not authorized by Dell is not covered by your warranty. Read and follow the safety instructions that came with the product.

1. Ensure that you read the [Safety instructions](#).
2. If applicable, remove the bezel.
3. Using the management software, prepare the hard drive for removal. Wait until the indicators on the hard-drive carrier signal that the hard drive can be removed safely. For more information, see the documentation for the storage controller.

If the hard drive is online, the green activity/fault indicator flashes as the drive is turned off. When the hard-drive indicators are off, the hard drive is ready for removal.

**CAUTION:** To prevent data loss, ensure that your operating system supports installation. See the documentation supplied with your operating system.

1. Press the release button to open the hard-drive carrier release handle.
2. Slide the hard-drive carrier out of the hard-drive slot.

**CAUTION:** To maintain proper system cooling, all empty hard-drive slots must have hard-drive blanks installed.

3. If you are not replacing the hard drive immediately, insert a hard-drive blank in the empty hard-drive slot.

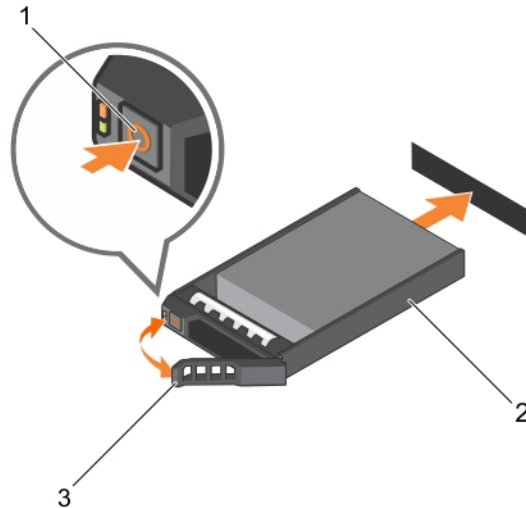

**Figure 11. Removing and installing hard drive**

- a. release button
- b. hard-drive carrier
- c. hard-drive carrier handle

## Installing Hard Drive

**CAUTION:** Many repairs may only be done by a certified service technician. You should only perform troubleshooting and simple repairs as authorized in your product documentation, or as directed by the online or telephone service and support team. Damage due to servicing that is not authorized by Dell is not covered by your warranty. Read and follow the safety instructions that came with the product.

**CAUTION:** Use only hard drives that have been tested and approved for use with the hard-drive backplane.

**CAUTION:** Combining SAS and SATA hard drives in the same RAID volume is not supported.

**CAUTION:** When installing a hard drive, ensure that the adjacent drives are fully installed. Inserting a hard-drive carrier and attempting to lock its handle next to a partially installed carrier can damage the partially installed carrier's shield spring and make it unusable.

**CAUTION:** After installing a replacement hard drive, power on the system and wait for the hard drive to automatically rebuild. Ensure the replacement hard drive is blank or contains data that you want to have overwritten. Any data on the replacement hard drive is immediately lost after the hard drive is installed.

**NOTE:** Hot swapping of hard drives are not supported.

1. If a hard-drive blank is installed in the hard-drive slot, remove it.
2. Install a hard drive in the hard-drive carrier.
3. Press the release button on the front of the hard-drive carrier and open the hard-drive carrier handle.
4. Insert the hard-drive carrier into the hard-drive slot until the carrier connects with the backplane.
5. Close the hard-drive carrier handle to lock the hard drive in place.

## Removing a hard drive from a hard-drive carrier

1. Keep the #1 Phillips screwdriver handy.
2. Remove the hard-drive carrier from the system.
1. Remove the screws from the slide rails on the hard-drive carrier.

2. Lift the hard drive out of the hard-drive carrier.

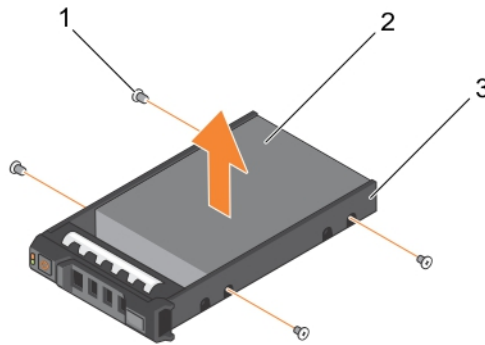

**Figure 12. Removing and installing a hard drive into a hard-drive carrier**

- a. screw (4)
- b. hard drive
- c. hard-drive carrier

## Installing a hard drive into a hard-drive carrier

**CAUTION:** Many repairs may only be done by a certified service technician. You should only perform troubleshooting and simple repairs as authorized in your product documentation, or as directed by the online or telephone service and support team. Damage due to servicing that is not authorized by Dell is not covered by your warranty. Read and follow the safety instructions that came with the product.

1. Insert the hard drive into the hard-drive carrier with the connector end of the hard drive toward the back.
2. Align the screw holes on the hard drive with the set of screw holes on the hard-drive carrier.  
When aligned correctly, the back of the hard drive is flush with the back of the hard-drive carrier.
3. Attach the screws to secure the hard drive to the hard-drive carrier.

## Optical drive (optional)

### Removing the optical drive

1. Ensure that you read the [Safety instructions](#).
2. Follow the procedure listed in [Before working inside your system](#).

**CAUTION:** Many repairs may only be done by a certified service technician. You should only perform troubleshooting and simple repairs as authorized in your product documentation, or as directed by the online or telephone service and support team. Damage due to servicing that is not authorized by Dell is not covered by your warranty. Read and follow the safety instructions that came with the product.

**NOTE:** This procedure applies only to the 8-hard drive system.

1. Disconnect the power/data cable from the back of the drive.  
Note the routing of the power/data cable on the side of the system as you remove them from the system board and drive. You must route these cables properly when you replace them to prevent them from being pinched or crimped.
2. To release the optical drive, press the release tab.
3. Slide the optical drive out of the system until it is free of the optical-drive slot.
4. If you are not adding a new optical drive, install the optical drive blank.

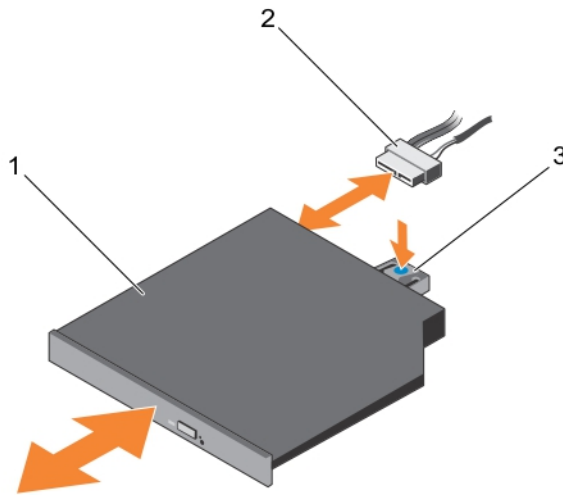

**Figure 13. Removing and installing the optical drive**

- a. optical drive
- b. power and data cable
- c. release tab

Follow the procedure listed in [After working inside your system](#).

## Installing the optical drive

1. Ensure that you read the [Safety instructions](#).
2. Follow the procedure listed in [Before working inside your system](#).

**CAUTION:** Many repairs may only be done by a certified service technician. You should only perform troubleshooting and simple repairs as authorized in your product documentation, or as directed by the online or telephone service and support team. Damage due to servicing that is not authorized by Dell is not covered by your warranty. Read and follow the safety instructions that came with the product.

**NOTE:** This procedure applies only to the 8-hard drive system.

1. Align the optical drive with the optical drive slot on the front of chassis.
2. Slide in the optical drive until the release tab snaps into place.
3. Connect the power/data cable to the optical drive and system board.

**NOTE:** You must route the cable properly on the side of the system to prevent it from being pinched or crimped.

Follow the procedure listed in [After working inside your system](#).

## Cooling fans

Your system supports six hot-swappable cooling fans.

**NOTE:** In the event of a problem with a particular fan, the fan number is referenced by the system management software, allowing you to easily identify and replace the proper fan by noting the fan numbers on the cooling-fan assembly.

## Removing a cooling fan

1. Ensure that you read the [Safety instructions](#).
2. Follow the procedure listed in [Before working inside your system](#).

**CAUTION:** Many repairs may only be done by a certified service technician. You should only perform troubleshooting and simple repairs as authorized in your product documentation, or as directed by the online or telephone service and support team. Damage due to servicing that is not authorized by Dell is not covered by your warranty. Read and follow the safety instructions that came with the product.

**CAUTION:** The cooling fans are hot-swappable. To maintain proper cooling while the system is on, replace only one fan at a time.

**NOTE:** The procedure for removing each fan is identical.

3. Press the fan release tab and lift the cooling fan out of the cooling-fan assembly.

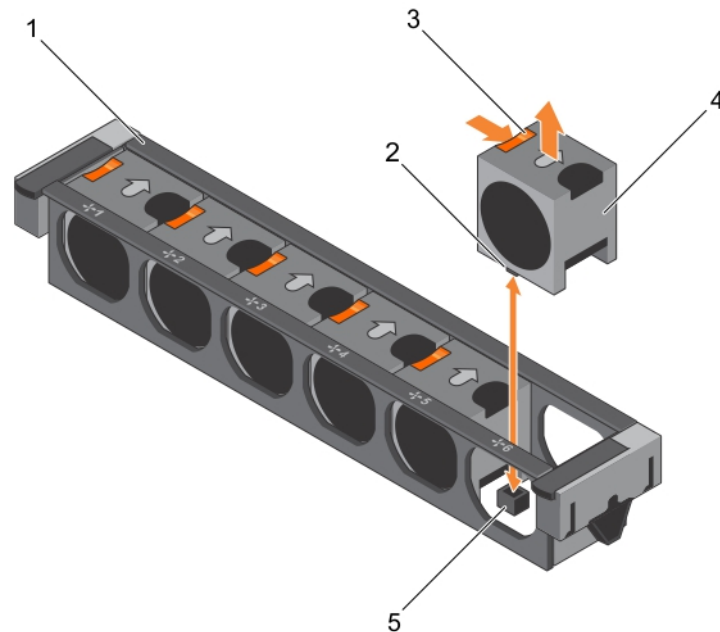

**Figure 14. Removing and installing a cooling fan**

- |  |                              |
|--|------------------------------|
| 1. cooling-fan assembly                      | 2. cooling-fan connector (6) |
| 3. fan release tab (6)                       | 4. cooling fan (6)           |
| 5. cooling-fan connector on system board (6) |                              |

To see a video on how to remove & install a fan or the fan assembly, scan this QR code, or click here: <http://www.Dell.com/QRL/Workstation/R7910/Fans>



4. Replace the cooling fan.
5. Follow the procedure listed in *After working inside your system*.

## Installing a cooling fan

1. Ensure that you read the *Safety instructions*.
2. Follow the procedure listed in *Before working inside your system*.



**CAUTION:** Many repairs may only be done by a certified service technician. You should only perform troubleshooting and simple repairs as authorized in your product documentation, or as directed by the online or telephone service and support team. Damage due to servicing that is not authorized by Dell is not covered by your warranty. Read and follow the safety instructions that came with the product.

**NOTE:** Your system supports six hot-swappable cooling fans.

1. Align the plug at the base of the cooling fan with the connector on the system board.
2. Slide the cooling fan into the securing slots until the tabs lock into place.

Follow the procedure listed in [After working inside your system](#).

To see a video on how to remove & install a fan or the fan assembly, scan this QR code, or click here: <http://www.Dell.com/QRL/>



[Workstation/R7910/Fans](#)

## Removing the cooling-fan assembly

1. Ensure that you read the [Safety Instructions](#)
2. Follow the procedure listed in [Before working inside your system](#).

**CAUTION:** Many repairs may only be done by a certified service technician. You should only perform troubleshooting and simple repairs as authorized in your product documentation, or as directed by the online or telephone service and support team. Damage due to servicing that is not authorized by Dell is not covered by your warranty. Read and follow the safety instructions that came with the product.

1. Unlock the cooling-fan assembly from the chassis by lifting the release levers upward.
2. Lift the cooling-fan assembly out of the chassis.

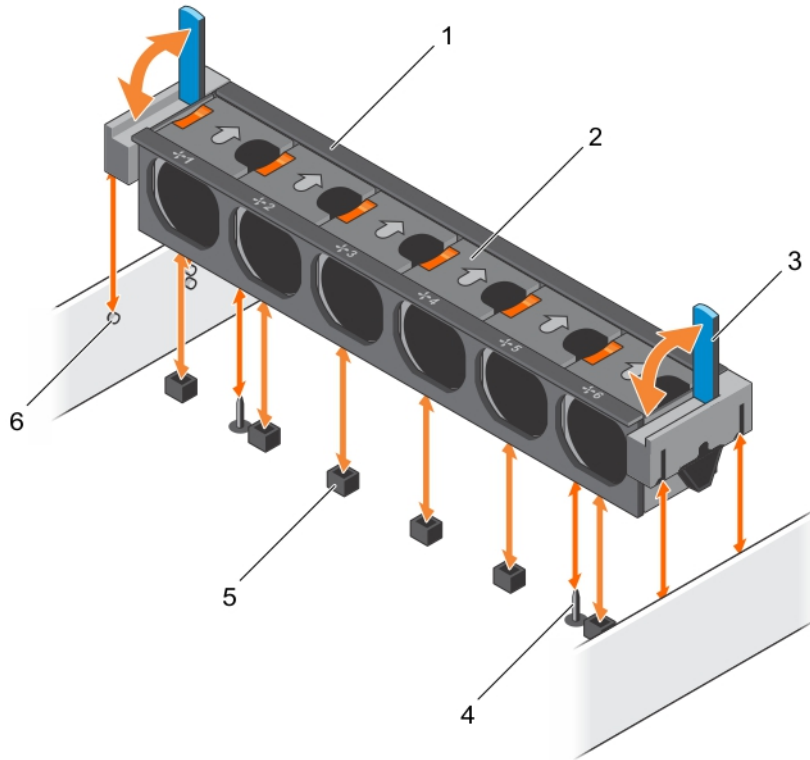

**Figure 15. Removing and installing the cooling-fan assembly**

- |                              |                                      |
|------------------------------|--------------------------------------|
| 1. cooling-fan assembly      | 2. cooling fan (6)                   |
| 3. release lever (2)         | 4. guide pin on the system board (2) |
| 5. cooling-fan connector (6) | 6. guide pin on the chassis (6)      |

To see a video on removing and installing a cooling-fan assembly, click <http://www.Dell.com/QRL/Server/PER730/Fans> or scan



the following QR code.

1. Replace the cooling-fan assembly.
2. Follow the procedure listed in [After working inside your system](#).

To see a video on how to remove & install a fan or the fan assembly, scan this QR code, or click here: <http://www.Dell.com/QRL/Workstation/R7910/Fans>



Workstation/R7910/Fans

## Installing the cooling-fan assembly

**CAUTION:** Many repairs may only be done by a certified service technician. You should only perform troubleshooting and simple repairs as authorized in your product documentation, or as directed by the online or telephone service and

**support team. Damage due to servicing that is not authorized by Dell is not covered by your warranty. Read and follow the safety instructions that came with the product.**

1. Ensure that you read the [Safety Instructions](#).
2. Follow the procedure listed in [Before working inside your system](#).

**CAUTION:** Ensure that the cables are correctly installed and retained by the cable retention bracket before installing the cooling-fan assembly. Incorrectly installed cables may get damaged.

1. Align the cooling-fan assembly slots with the guide pins on the chassis.
2. Slide the cooling-fan assembly into the chassis.
3. Lock the cooling-fan assembly into the chassis by lowering the release levers until firmly seated.

To see a video on how to remove & install a fan or the fan assembly, scan this QR code, or click here: <http://www.Dell.com/QRL/>



[Workstation/R7910/Fans](#)

Follow the procedure listed in [After working inside your system](#).

## Internal USB memory key (optional)

An optional USB memory key installed inside your system can be used as a boot device, security key, or mass storage device. The USB connector must be enabled by the **Internal USB Port** option in the **Integrated Devices** screen of the System Setup.

To boot from the USB memory key, configure the USB memory key with a boot image and then specify the USB memory key in the boot sequence in the System Setup.

## Replacing the internal USB key

1. Ensure that you read the [Safety instructions](#).
2. Follow the procedure listed in [Before working inside your system](#).

**CAUTION:** Many repairs may only be done by a certified service technician. You should only perform troubleshooting and simple repairs as authorized in your product documentation, or as directed by the online or telephone service and support team. Damage due to servicing that is not authorized by Dell is not covered by your warranty. Read and follow the safety instructions that came with the product.

1. Locate the USB connector or USB key on the system board.
2. If installed, remove the USB key.
3. Insert the new USB key into the USB connector.

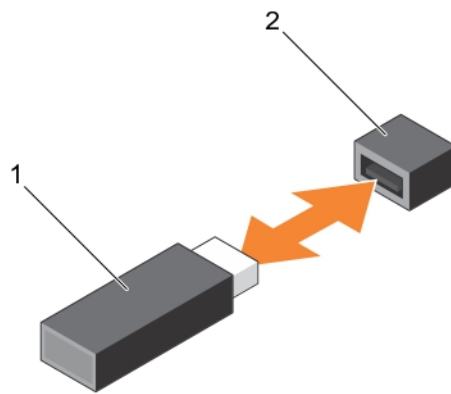

**Figure 16. Replacing the internal USB key**

- a. USB memory key
- b. USB memory key connector

1. Follow the procedure listed in [After working inside your system](#).
2. While booting, press <F2> to enter the **System Setup** and verify that the USB key is detected by the system.

## PCIe card holder

### Removing the PCIe card holder

1. Ensure that you read the [Safety instructions](#).
2. Follow the procedure listed in [Before working inside your system](#).
3. If installed, remove the full-length PCIe card.

**CAUTION:** Many repairs may only be done by a certified service technician. You should only perform troubleshooting and simple repairs as authorized in your product documentation, or as directed by the online or telephone service and support team. Damage due to servicing that is not authorized by Dell is not covered by your warranty. Read and follow the safety instructions that came with the product.

**CAUTION:** Do not use your system without the PCIe card holder installed. The PCIe card holder is necessary to ensure proper system cooling.

1. Press the release tab and slide the card holder toward the back of the chassis to release the PCIe card holder from the chassis.
2. Lift the PCIe card holder out of the chassis.

**NOTE:** To ensure proper system cooling, you must replace the PCIe card holder.

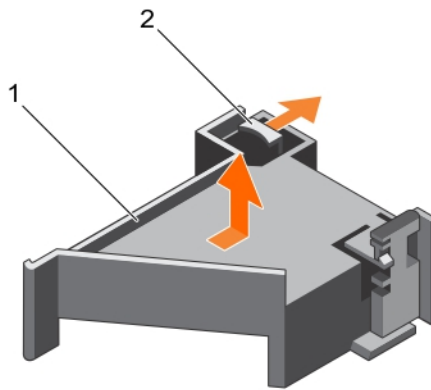

**Figure 17. Removing and installing the PCIe card holder**

- a. PCIe card holder
- b. release tab

1. Replace the PCIe card holder.
2. Follow the procedure listed in [After working inside your system](#).

To see a video on how to remove & install a PCI card and riser, scan this QR code, or click here: <http://www.Dell.com/QRL/Workstation/>



R7910/PCI

## Installing the PCIe card holder

1. Ensure that you read the [Safety instructions](#).
2. Follow the procedure listed in [Before working inside your system](#).

**CAUTION:** Many repairs may only be done by a certified service technician. You should only perform troubleshooting and simple repairs as authorized in your product documentation, or as directed by the online or telephone service and support team. Damage due to servicing that is not authorized by Dell is not covered by your warranty. Read and follow the safety instructions that came with the product.

**CAUTION:** Do not use your system without the PCIe card holder installed. The PCIe card holder is necessary to ensure proper system cooling.

1. Align the PCIe card holder with the notches and tabs on the power supply unit cage.
  2. Press the release tab and slide PCIe card holder toward the front of the chassis until firmly seated.
1. If applicable, replace the full-length PCIe card.
  2. Follow the procedure listed in [After working inside your system](#).

To see a video on how to remove & install a PCI card and riser, scan this QR code, or click here: <http://www.Dell.com/QRL/Workstation/>



R7910/PCI

## Opening and closing the PCIe card holder latch

1. Ensure that you read the [Safety instructions](#).
2. Follow the procedure listed in [Before working inside your system](#).

**CAUTION:** Many repairs may only be done by a certified service technician. You should only perform troubleshooting and simple repairs as authorized in your product documentation, or as directed by the online or telephone service and support team. Damage due to servicing that is not authorized by Dell is not covered by your warranty. Read and follow the safety instructions that came with the product.

1. To open the PCIe card holder latch, press the release tab.
2. To close the PCIe card holder latch, rotate the latch clockwise until it locks.

**NOTE:** Before installing a full-length PCIe card, the PCIe card holder latch must be closed. When the full-length PCIe card is installed, open the PCIe card holder latch. Before removing the full-length PCIe card, you must close the PCIe card holder latch.

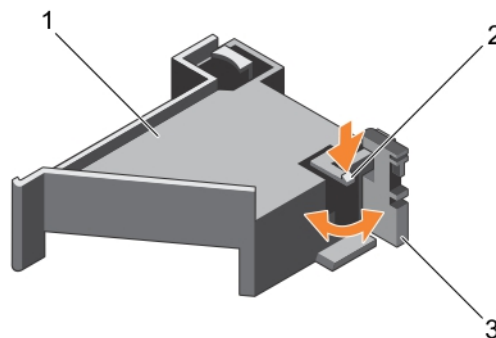

**Figure 18. Opening and closing the PCIe card holder latch**

- a. PCIe card holder
- b. release tab
- c. PCIe card holder latch

Follow the procedure listed in [After working inside your system](#).

## Cable retention bracket

### Removing the cable retention bracket

1. Ensure that you read the [Safety instructions](#).
2. Follow the procedure listed in [Before working inside your system](#).

3. Remove the cooling shroud.
4. Remove the PCIe card holder.
5. Remove all cables routed through the cable retention bracket.

**CAUTION:** Many repairs may only be done by a certified service technician. You should only perform troubleshooting and simple repairs as authorized in your product documentation, or as directed by the online or telephone service and support team. Damage due to servicing that is not authorized by Dell is not covered by your warranty. Read and follow the safety instructions that came with the product.

1. Pull the tab to release it from the notch and slide the cable retention bracket toward the front of the chassis to release it from the chassis.
2. Lift the cable retention bracket out of the chassis.

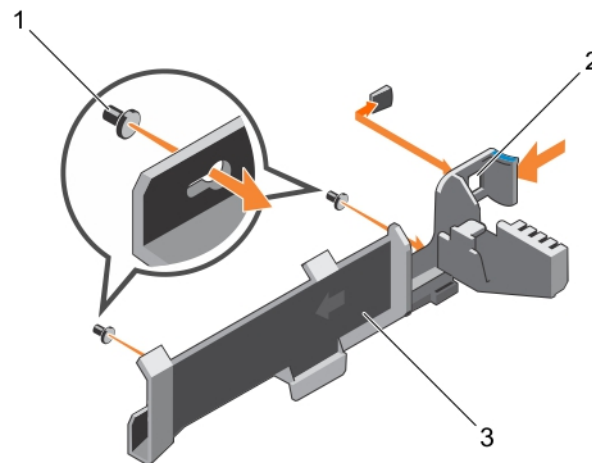

**Figure 19. Removing and installing the cable retention bracket**

- a. alignment pin (2)
- b. tab
- c. cable retention bracket

1. Follow the procedure listed in [After working inside your system](#).

## Installing the cable retention bracket

1. Ensure that you read the [Safety instructions](#).
2. Follow the procedure listed in [Before working inside your system](#).
3. Remove the cooling shroud.
4. Remove the PCIe card holder.

**CAUTION:** Many repairs may only be done by a certified service technician. You should only perform troubleshooting and simple repairs as authorized in your product documentation, or as directed by the online or telephone service and support team. Damage due to servicing that is not authorized by Dell is not covered by your warranty. Read and follow the safety instructions that came with the product.

1. Align the cable retention bracket with the alignment pins on the chassis.
2. Slide the cable retention bracket along the chassis wall until the tab clicks and locks the slots.
3. Place all cables to be routed in the cable retention bracket.

1. Install the PCIe card holder.
2. Install the cooling shroud.
3. Follow the procedure listed in [After working inside your system](#).

# Expansion cards and expansion card risers

**NOTE:** A missing or an unsupported expansion card riser logs a System Event Log (SEL). It does not prevent your system from powering on. A no BIOS POST message or F1/F2 pause is displayed.

## Expansion card installation guidelines

Depending on your system configuration:

The following PCI Express generation 3 Expansion Card Risers are supported :

**Table 8. Supported expansion cards**

Riser	PCIe Slot	Processor Connection	Height	Length	Link Width	Slot Width
1	1	Processor 2	Low Profile	Half Length	x8	x16
1	2	Processor 2	Low Profile	Half Length	x8	x16
1	3	Processor 2	Low Profile	Half Length	x8	x16
2	4	Processor 2	Full Height	Full Length	x16	x16
2	5	Processor 1	Full Height	Full Length	x8	x16
3 (default)	6	Processor 1	Full Height	Full Length	x8	x16
3 (alternate)	6	Processor 1	Full Height	Full Length	x16	x16
3 (default)	7	Processor 1	Full Height	Full Length	x8	x16

**NOTE:** To use PCIe slots 1 through 4 on the riser, both the processors must be installed.

**NOTE:** The expansion-card slots are not hot-swappable.

## Removing an expansion card from expansion-card riser 2 or 3

**CAUTION:** Many repairs may only be done by a certified service technician. You should only perform troubleshooting and simple repairs as authorized in your product documentation, or as directed by the online or telephone service and support team. Damage due to servicing that is not authorized by Dell is not covered by your warranty. Read and follow the safety instructions that came with the product.

1. Ensure that you read the [Safety instructions](#).
2. Follow the procedure listed in [Before working inside your system](#).
3. When removing a card from Riser 3, ensure that the PCIe holder latch is closed.

**NOTE:** The procedure for installing and removing a full length PCIe card is similar to the procedure for removing and installing a GPU card.

1. Disconnect any cables connected to the expansion card.
2. Lift the expansion-card latch out of the slot.
3. Hold the expansion card by its edges, and remove it from the expansion-card connector.
4. If you are removing the card permanently, install a metal filler bracket over the empty expansion slot opening and close the expansion-card latch.
5. Replace the expansion-card latch into the slot.
6. Close the expansion-card locking tabs.

**NOTE:** You must install a filler bracket over an empty expansion card slot to maintain Federal Communications Commission (FCC) certification of the system. The brackets also keep dust and dirt out of the system and aid in proper cooling and airflow inside the system.



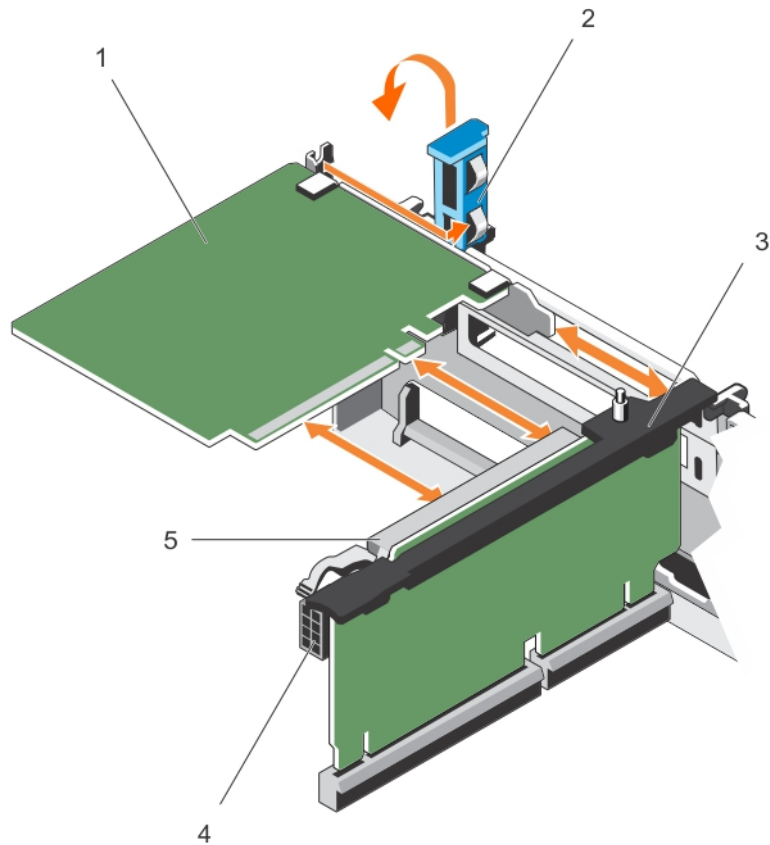

**Figure 20. Removing and installing an expansion card from expansion-card riser 2 or 3**

- |                             |                                    |
|-----------------------------|------------------------------------|
| 1. expansion card           | 2. expansion-card latch            |
| 3. expansion-card riser     | 4. power connector (for GPU cards) |
| 5. expansion-card connector |                                    |

To see a video on how to remove & install a PCI card and riser, scan this QR code, or click here: <http://www.Dell.com/QRL/Workstation/>



R7910/PCI

Follow the procedure listed in [After working inside your system.](#)

## Installing an expansion card into the expansion-card riser 2 or 3

1. Ensure that you read the [Safety instructions.](#)
2. Follow the procedure listed in [Before working inside your system.](#)

**CAUTION:** Many repairs may only be done by a certified service technician. You should only perform troubleshooting and simple repairs as authorized in your product documentation, or as directed by the online or telephone service and support team. Damage due to servicing that is not authorized by Dell is not covered by your warranty. Read and follow the safety instructions that came with the product.

1. Unpack the expansion card and prepare it for installation.  
For instructions, see the documentation accompanying the card.
2. Lift the expansion-card latch and remove the filler bracket.
3. Holding the card by its edges, position the card so that the connector on the expansion card aligns with the expansion-card connector on the riser.
4. Insert the card-edge connector firmly into the expansion-card connector until the card is fully seated.
5. Press the touch points to open the expansion-card locking tabs.
6. Replace the expansion-card latch.
7. If applicable, connect the cables to the expansion card.

**NOTE:** When installing a GPU card on riser 2 or riser 3 (default), connect the GPU card power cable to the power connector on the riser.

1. Follow the procedure listed in [After working inside your system](#).
2. Install any device drivers required for the card as described in the documentation for the card.

To see a video on how to remove & install a PCI card and riser, scan this QR code, or click here: <http://www.Dell.com/QRL/Workstation/>



R7910/PCI

## Removing an expansion card from the expansion-card riser

### 1

**CAUTION:** Many repairs may only be done by a certified service technician. You should only perform troubleshooting and simple repairs as authorized in your product documentation, or as directed by the online or telephone service and support team. Damage due to servicing that is not authorized by Dell is not covered by your warranty. Read and follow the safety instructions that came with the product.

1. Ensure that you read the [Safety instructions](#).
2. Follow the procedure listed in [Before working inside your system](#).
3. Disconnect any cables connected to the expansion card.
4. Remove the expansion-card riser. Pull straight up on the riser using the blue touch points on the top of the riser.

**NOTE:** The expansion-card riser 1 can be used only when both the processors are installed.

1. Press tab A and rotate the latch clockwise.
2. Press tab B and rotate the latch downward.
3. Remove the expansion card from the expansion-card riser.
4. If you are removing the card permanently, install a metal filler bracket over the empty expansion slot opening and close the expansion-card latch.
5. Close the latches of tab A and tab B.

**NOTE:** You must install a filler bracket over an empty expansion card slot to maintain Federal Communications Commission (FCC) certification of the system. The brackets also keep dust and dirt out of the system and aid in proper cooling and airflow inside the system.

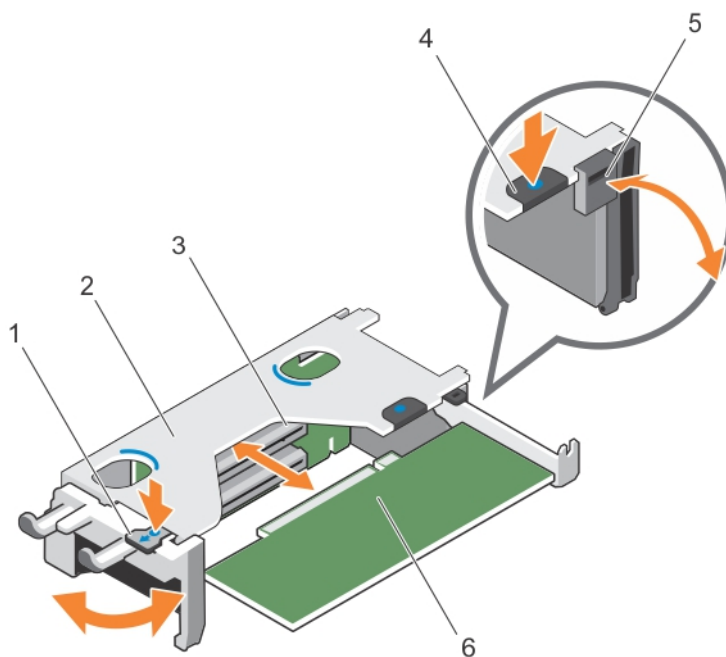

**Figure 21. Removing and installing an expansion-card from expansion-card riser 1**

- |                             |                                |
|-----------------------------|--------------------------------|
| 1. tab A                    | 2. expansion-card riser 1 cage |
| 3. expansion-card connector | 4. tab B                       |
| 5. latch                    | 6. expansion card              |

1. Install the expansion-card riser.
2. Follow the procedure listed in [After working inside your system](#).

To see a video on how to remove & install a PCI card and riser, scan this QR code, or click here: <http://www.Dell.com/QLR/Workstation/>



R7910/PCI

## Installing an expansion card into the expansion-card riser 1

1. Ensure that you read the [Safety instructions](#).
2. Follow the procedure listed in [Before working inside your system](#).
3. Remove the expansion-card riser. Pull straight up on the riser using the blue touch points on the top of the riser

**CAUTION:** Many repairs may only be done by a certified service technician. You should only perform troubleshooting and simple repairs as authorized in your product documentation, or as directed by the online or telephone service and support team. Damage due to servicing that is not authorized by Dell is not covered by your warranty. Read and follow the safety instructions that came with the product.

**NOTE:** The expansion-card riser 1 can be used only when both the processors are installed.

1. Unpack the expansion card and prepare it for installation.  
For instructions, see the documentation accompanying the card.
  2. Press tab A and rotate the latch clockwise.
  3. Press tab B and rotate the latch down.
  4. Holding the card by its edges, position the card so that the card-edge connector aligns with the expansion-card connector.
  5. Insert the card-edge connector firmly into the expansion-card connector until the card is fully seated.
  6. Close the latches of tab A and tab B.
1. Install the expansion-card riser.
  2. If applicable, connect any cables to the expansion card.
  3. Follow the procedure listed in [After working inside your system](#).
  4. Install any device drivers required for the card as described in the documentation for the card.

To see a video on how to remove & install a PCI card and riser, scan this QR code, or click here: <http://www.Dell.com/QRL/Workstation/>



R7910/PCI

## Removing the riser 1 blank

**⚠ CAUTION:** Many repairs may only be done by a certified service technician. You should only perform troubleshooting and simple repairs as authorized in your product documentation, or as directed by the online or telephone service and support team. Damage due to servicing that is not authorized by Dell is not covered by your warranty. Read and follow the safety instructions that came with the product.

1. Ensure that you read the [Safety instructions](#).
2. Follow the procedure listed in [Before working inside your system](#).
3. Remove the expansion-card riser.
4. Press the tabs on the riser 1 blank and push the riser 1 blank out of the chassis.

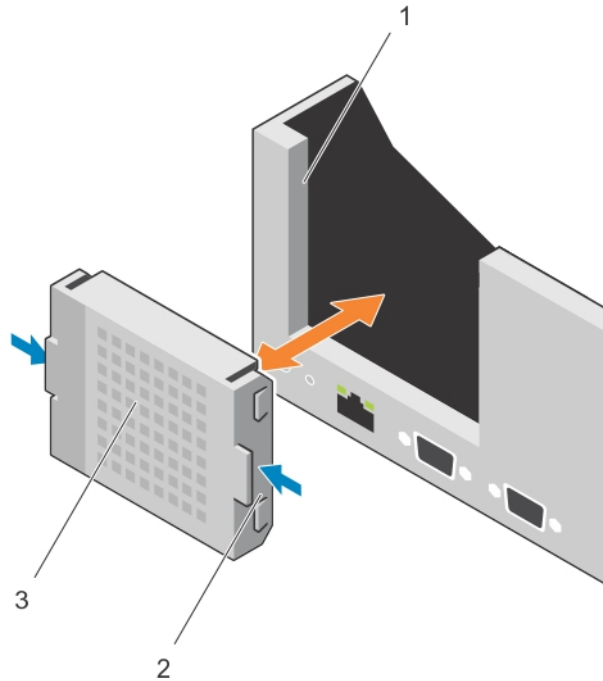

**Figure 22. Removing and installing the riser 1 blank**

- a. slot on the chassis
- b. tab (2)
- c. riser 1 blank

## Installing the riser 1 blank

1. Align the blank with the slot on the chassis.
2. Insert it into the chassis until it clicks into place.

## Removing expansion-card risers

**CAUTION:** Many repairs may only be done by a certified service technician. You should only perform troubleshooting and simple repairs as authorized in your product documentation, or as directed by the online or telephone service and support team. Damage due to servicing that is not authorized by Dell is not covered by your warranty. Read and follow the safety instructions that came with the product.

1. Ensure that you read the [Safety instructions](#).
2. Follow the procedure listed in [Before working inside your system](#).
3. If installed, remove any expansion card installed on riser 2 and 3.

**NOTE:** The expansion-card riser 1 can be used only when both the processors are installed.

Holding the slots on the expansion-card riser, lift the riser from the riser connector on the system board.

**NOTE:** To remove expansion-card risers 2 and 3, hold the edges of the expansion-card riser.

**NOTE:** To ensure proper system cooling, the riser 1 blank must be installed in the riser 1 slot. Remove the riser 1 blank only if you are installing riser 1.

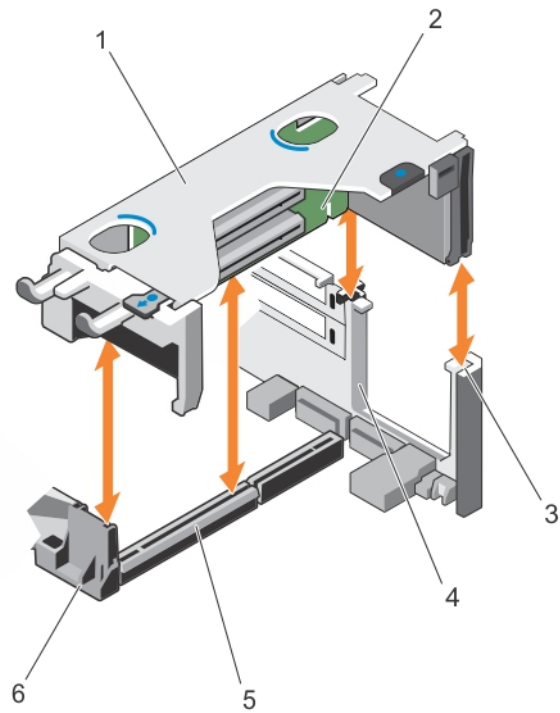

**Figure 23. Removing and installing the expansion card riser 1**

- |                                     |                            |
|-------------------------------------|----------------------------|
| 1. expansion-card riser 1 cage      | 2. expansion-card riser 1  |
| 3. riser guide-back (right)         | 4. riser guide-back (left) |
| 5. expansion-card riser 1 connector | 6. riser guide-front       |

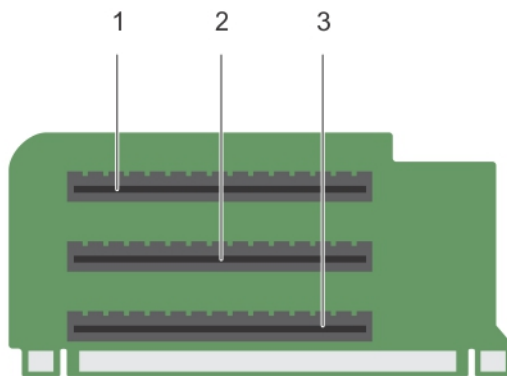

**Figure 24. Identifying connectors on the expansion card riser 1**

- a. expansion-card slot 1
- b. expansion-card slot 2
- c. expansion-card slot 3

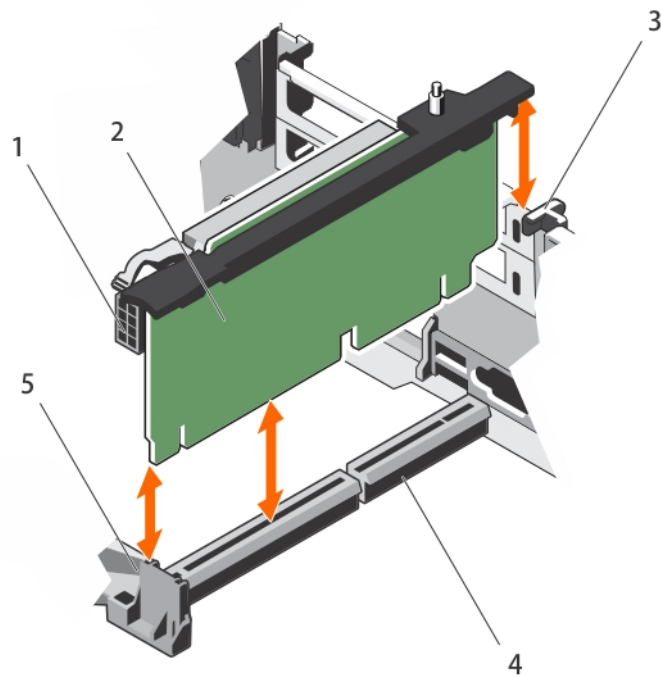

**Figure 25. Removing and installing the expansion card riser 2**

- |                                    |                                     |
|------------------------------------|-------------------------------------|
| 1. power connector (for GPU cards) | 2. expansion-card riser 2           |
| 3. riser guide-back                | 4. expansion-card riser 2 connector |
| 5. riser guide-front               |                                     |

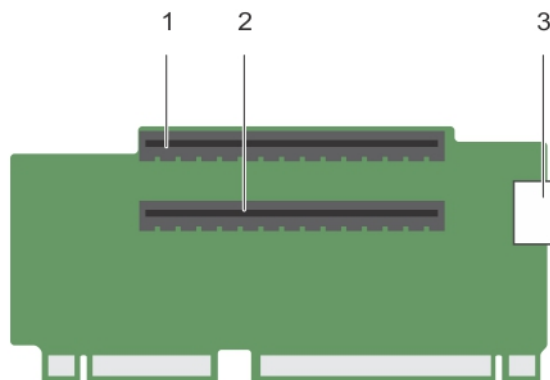

**Figure 26. Identifying connectors on the expansion card riser 2**

- |                                    |
|------------------------------------|
| a. expansion-card slot 4           |
| b. expansion-card slot 5           |
| c. power connector (for GPU cards) |

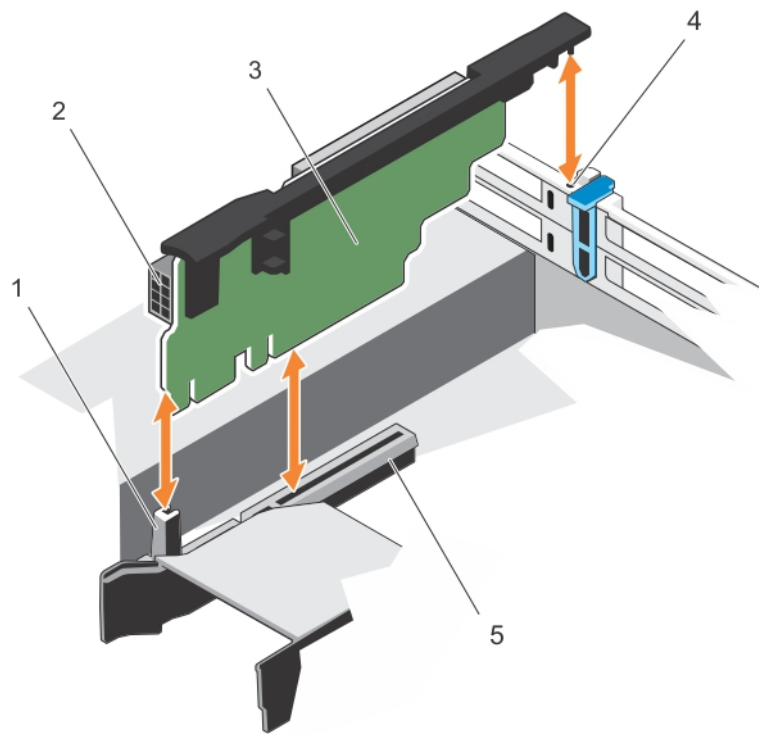

**Figure 27. Removing and installing the expansion card riser 3**

- |                                     |                                    |
|-------------------------------------|------------------------------------|
| 1. riser guide-front                | 2. power connector (for GPU cards) |
| 3. expansion-card riser 3           | 4. riser guide-back                |
| 5. expansion-card riser 3 connector |                                    |

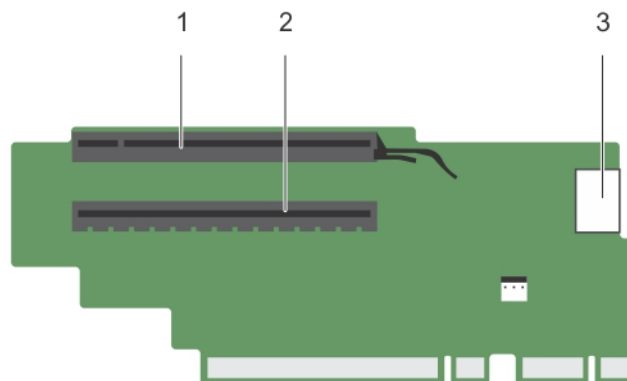

**Figure 28. Identifying connectors on the expansion card riser 3 (default)**

- |                                    |
|------------------------------------|
| a. expansion-card slot 6           |
| b. expansion-card slot 7           |
| c. power connector (for GPU cards) |



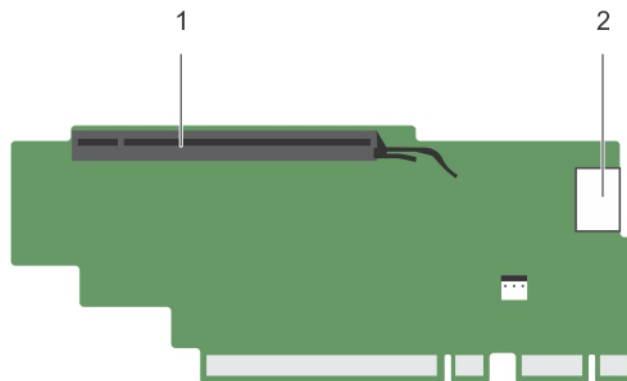

**Figure 29. Identifying connectors on the expansion card riser 3 (alternate)**

- a. expansion-card slot 6
  - b. power connector (for GPU cards)
1. If applicable, remove or install an expansion card on the riser.
  2. If applicable, replace the expansion-card riser.
  3. Follow the procedure listed in [After working inside your system](#).

## Installing expansion-card risers

1. Ensure that you read the [Safety instructions](#).
2. Follow the procedure listed in [Before working inside your system](#).
3. If applicable, reinstall the expansion card(s) into the expansion-card riser 1.

**CAUTION:** Many repairs may only be done by a certified service technician. You should only perform troubleshooting and simple repairs as authorized in your product documentation, or as directed by the online or telephone service and support team. Damage due to servicing that is not authorized by Dell is not covered by your warranty. Read and follow the safety instructions that came with the product.

1. Align the expansion-card riser with the connectors and the riser guides on the system board.
  2. Lower the expansion-card riser into place until the expansion-card riser is fully seated in the connector.
1. Install the expansion card(s) into the expansion-card risers 2 or 3.
  2. Follow the procedure listed in [After working inside your system](#).
  3. Install any device drivers required for the card as described in the documentation for the card.

## GPU card installation guidelines

**NOTE:** Internal GPU cards are supported on the Precision Rack 7910.

- The Precision Rack 7910 must be installed with one processor for 5, 6, 7 PCIe slots.
- If quantity 2 K6000 or K20 Cards are used along with 160 w processors, the system inlet temperature is restricted to 30 c to ensure adequate system cooling.
- All GPU cards must be of the same type and model.
- You can install up to two double-wide GPU cards.

**NOTE:** Two double-wide GPU cards configuration requires optional riser 3.

- You can install up to four single-wide GPU cards.

## Installing a GPU card

1. Ensure that you read the [Safety instructions](#).
2. Follow the procedure listed in [Before working inside your system](#).

**CAUTION:** Many repairs may only be done by a certified service technician. You should only perform troubleshooting and simple repairs as authorized in your product documentation, or as directed by the online or telephone service and support team. Damage due to servicing that is not authorized by Dell is not covered by your warranty. Read and follow the safety instructions that came with the product.

1. Unpack the GPU cards.
2. Close the expansion-card locking tab on the cooling shroud and riser.
3. Lift the expansion-card latch.
4. Remove the filler brackets for the single- or double-wide GPU cards.
5. Align the GPU card connector with the slot on the riser.
6. Insert the GPU card into the riser slot until it is fully seated.
7. Locate the GPU power connectors on the cable and plug them to the 6-pin and 8-pin connectors on the GPU card if required (not all GPU cards require external power connectors).

**NOTE:** Ensure the GPU card is installed correctly into the GPU card lock.

8. Press down on the GPU card lock to secure the card in position.
9. Ensure the GPU card is seated into the PCIe card holder latch.
10. Press the touch point to open the PCIe card holder latch and/or the expansion-card locking tabs.
11. Connect the GPU power cable to the riser.
12. Close the expansion-card latch/latches.

Follow the procedure listed in [After working inside your system](#).

## Removing a GPU card

1. Ensure that you read the [Safety instructions](#).
2. Follow the procedure listed in [Before working inside your system](#).

**CAUTION:** Many repairs may only be done by a certified service technician. You should only perform troubleshooting and simple repairs as authorized in your product documentation, or as directed by the online or telephone service and support team. Damage due to servicing that is not authorized by Dell is not covered by your warranty. Read and follow the safety instructions that came with the product.

1. Lift the expansion-card latch.
2. Close the expansion-card locking tabs on the cooling shroud and the risers.
3. Hold the GPU card by its edges and slide out the GPU card at an angle to release it from the connector on the riser card.
4. Disconnect the cable from the GPU card.
5. If you are removing the card permanently, install a metal filler bracket over the empty slot opening and close the expansion-card locking tabs.

**NOTE:** You must install a filler bracket over an empty expansion card slot to maintain Federal Communications Commission (FCC) certification of the system. The brackets also keep dust and dirt out of the system and aid in proper cooling and airflow inside the system.

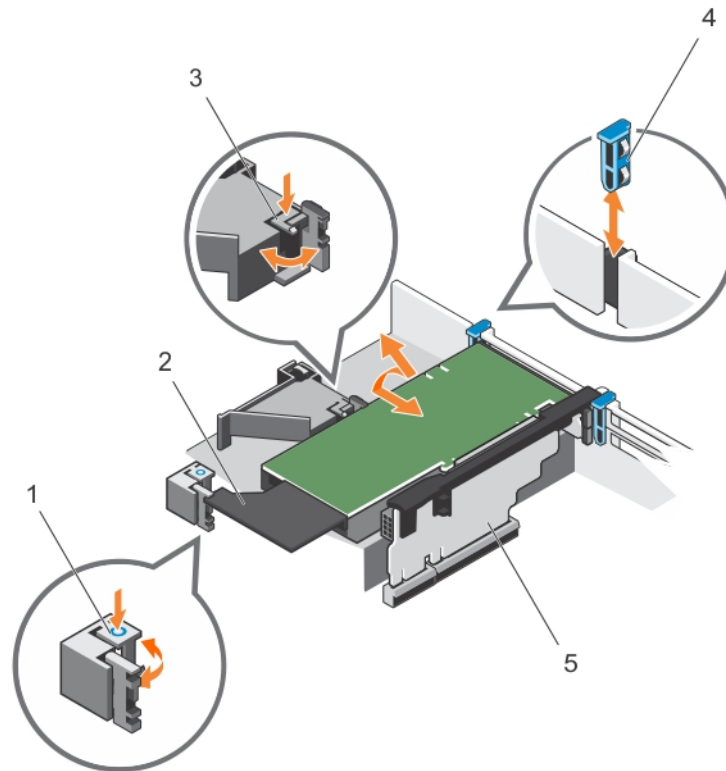

**Figure 30. Removing and installing the GPU card**

- |                                   |                         |
|-----------------------------------|-------------------------|
| 1. expansion-card locking tab (3) | 2. GPU card             |
| 3. PCIe card holder latch         | 4. expansion-card latch |
| 5. expansion-card riser           |                         |

Follow the procedure listed in [After working inside your system](#).

## SD vFlash media card (optional)

An SD vFlash card is a Secure Digital (SD) card that plugs into the SD vFlash card slot in the iDRAC port card. It provides persistent on-demand local storage and a custom deployment environment that enables automation of server configuration, scripts, and imaging. It emulates USB device(s). For more information, see the Integrated Dell Remote Access Controller User's Guide at [Dell.com/idracmanuals](http://Dell.com/idracmanuals).

## Replacing an SD vFlash media card

1. Locate the SD vFlash media slot on the system.  
For Precision Rack 7910 systems it is located on the back panel of the system.
2. To remove the SD vFlash media card, push the card inward to release it, and pull the card from the card slot.

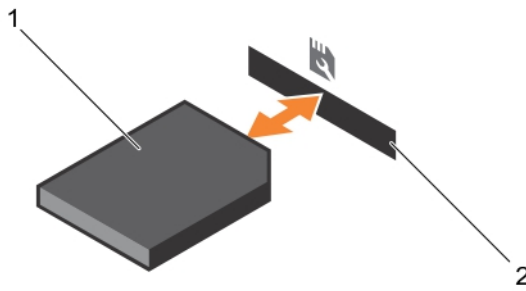

**Figure 31. Removing and installing the SD vFlash media card**

- a. SD vFlash media card
  - b. SD vFlash media-card slot
3. To install an SD vFlash media card, with the label side facing up, insert the contact-pin end of the SD vFlash media card into the card slot on the module.
- i** **NOTE:** The slot is keyed to ensure correct insertion of the card.
4. Press the card inward to lock it into the slot.

## Internal dual SD module (optional)

The Internal Dual SD Module (IDSDM) card provides two SD card slots. This card offers the following features:

- Dual card operation — maintains a mirrored configuration by using SD cards in both the slots and provides redundancy.
- i** **NOTE:** When the Redundancy option is set to Mirror Mode in the Integrated Devices screen of System Setup, the information is replicated from one SD card to another.
- Single card operation — single card operation is supported, but without redundancy.

## Removing an internal SD card

1. Ensure that you read the [Safety instructions](#).
2. Follow the procedure listed in [Before working inside your system](#).
3. Locate the SD card slot on the internal dual SD module and press the card to release it from the slot.
4. Follow the procedure listed in [After working inside your system](#)

**⚠ CAUTION:** Many repairs may only be done by a certified service technician. You should only perform troubleshooting and simple repairs as authorized in your product documentation, or as directed by the online or telephone service and support team. Damage due to servicing that is not authorized by Dell is not covered by your warranty. Read and follow the safety instructions that came with the product.

To see a video on how to remove & install the internal dual SD module and SD cards, scan this QR code, or click here: <http://www.Dell.com/QRL/Workstation/R7910/IDSM>



# Installing an internal SD card

1. Ensure that you read the [Safety instructions](#).
2. Follow the procedure listed in [Before working inside your system](#).

**CAUTION:** Many repairs may only be done by a certified service technician. You should only perform troubleshooting and simple repairs as authorized in your product documentation, or as directed by the online or telephone service and support team. Damage due to servicing that is not authorized by Dell is not covered by your warranty. Read and follow the safety instructions that came with the product.

**NOTE:** To use an SD card with your system, ensure that the Internal SD Card Port is enabled in the System Setup.

1. Locate the SD card connector on the internal dual SD module system motherboard.. Orient the SD card appropriately and insert the contact-pin end of the card into the slot.

**NOTE:** The slot is keyed to ensure correct insertion of the card.

2. Press the card into the card slot to lock it into place.
  1. If removed, replace the cooling shroud.
  2. Follow the procedure listed in [After working inside your system](#).

To see a video on how to remove & install the internal dual SD module and SD cards, scan this QR code, or click here: <http://www.Dell.com/QRL/Workstation/R7910/IDSM>



# Removing the internal dual SD module

1. Ensure that you read the [Safety instructions](#).
2. Follow the procedure listed in [Before working inside your system](#).

**CAUTION:** Many repairs may only be done by a certified service technician. You should only perform troubleshooting and simple repairs as authorized in your product documentation, or as directed by the online or telephone service and support team. Damage due to servicing that is not authorized by Dell is not covered by your warranty. Read and follow the safety instructions that came with the product.

1. Locate the internal dual SD module on the system board.
2. If installed, remove the SD card(s).
3. Hold the plastic pull tab and pull the dual SD module out of the system board.

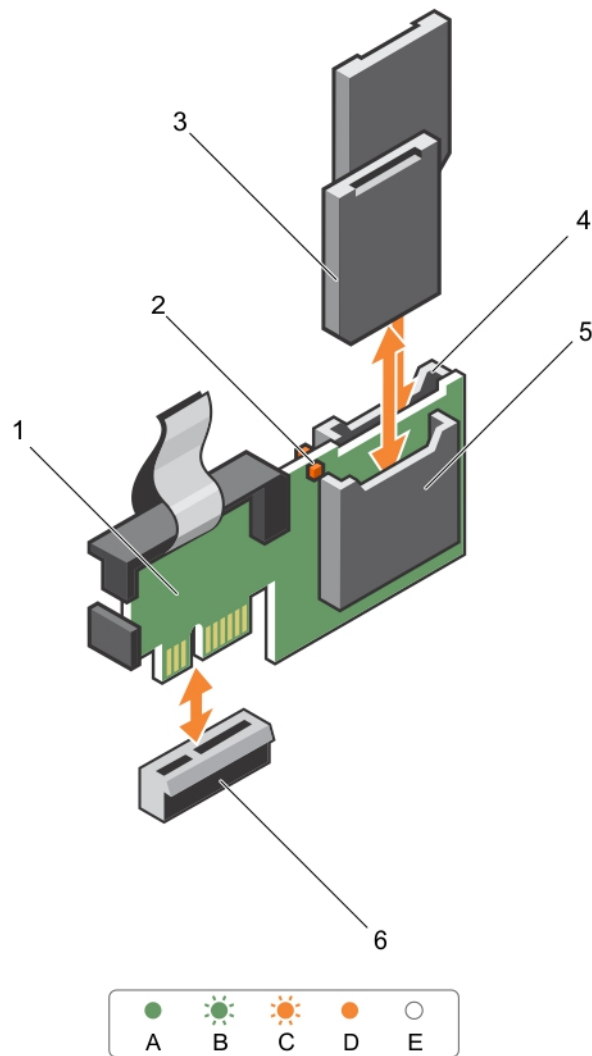

**Figure 32. Removing and installing the Internal Dual SD Module (IDSDM)**

- |                            |                             |
|----------------------------|-----------------------------|
| 1. Internal Dual SD module | 2. LED status indicator (2) |
| 3. SD card (2)             | 4. SD card slot 2           |
| 5. SD card slot 1          | 6. IDSDM connector          |

The following table describes the IDSDM indicator codes.

Convention	IDSDM indicator code	Condition
A	Green	Indicates that the card is online
B	Flashing green	Indicates rebuild or activity
C	Flashing amber	Indicates card mismatch or that the card has failed
D	Amber	Indicates that the card is offline, has failed, or is write protected
E	Not lit	Indicates that the card is missing or is booting

Follow the procedure listed in [After working inside your system](#).

To see a video on how to remove & install the internal dual SD module and SD cards, scan this QR code, or click here: <http://www.Dell.com/QRL/Workstation/R7910/IDSM>



## Installing the internal dual SD module

1. Ensure that you read the [Safety instructions](#).
2. Follow the procedure listed in [Before working inside your system](#).

**CAUTION:** Many repairs may only be done by a certified service technician. You should only perform troubleshooting and simple repairs as authorized in your product documentation, or as directed by the online or telephone service and support team. Damage due to servicing that is not authorized by Dell is not covered by your warranty. Read and follow the safety instructions that came with the product.

1. Locate the IDSDM connector on the system board.
  2. Align the connectors on the system board and the dual SD module.
  3. Push the dual SD module until it is firmly seated on the system board.
1. Install the SD vFlash media card(s).
  2. Follow the procedure listed in [After working inside your system](#).

To see a video on how to remove & install the internal dual SD module and SD cards, scan this QR code, or click here: <http://www.Dell.com/QRL/Workstation/R7910/IDSM>



## Integrated storage controller card

Your system includes a dedicated expansion card slot on the system board for an integrated controller card. The integrated storage controller card provides the integrated storage subsystem for the internal hard drives in your system. The controller supports SAS and SATA hard drives and also enables you to set up the hard drives in RAID configurations. The RAID configurations depend on the version of the storage controller included with your system.

## Removing the integrated storage controller card

1. Ensure that you read the [Safety instructions](#).
2. Follow the procedure listed in [Before working inside your system](#).
3. Remove the cooling shroud.
4. Remove the expansion-card riser 1.
5. Keep the #2 Phillips screwdriver handy.

**CAUTION:** Many repairs may only be done by a certified service technician. You should only perform troubleshooting and simple repairs as authorized in your product documentation, or as directed by the online or telephone service and support team. Damage due to servicing that is not authorized by Dell is not covered by your warranty. Read and follow the safety instructions that came with the product.

1. Loosen the screws that secure the integrated storage controller cable to the integrated storage-controller card connector on the system board.
2. Lift the integrated storage controller cable out.
3. Lift one end of the card and angle it to disengage the card from the integrated storage-controller card holder on system board.
4. Lift the card out of the chassis.

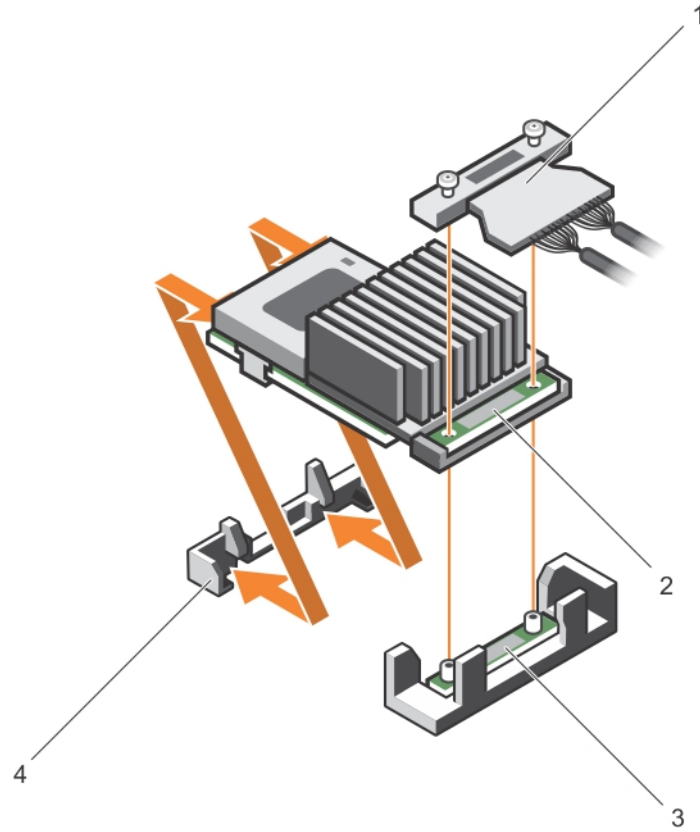

**Figure 33. Removing and installing the integrated storage controller card**

- |   |  |
|---|--|
| 1. integrated storage controller cable                              | 2. integrated storage controller card        |
| 3. integrated storage-controller card connector on the system board | 4. integrated storage controller card holder |

1. Replace the expansion-card riser 1.
2. Replace the cooling shroud.
3. Follow the procedure listed in [After working inside your system](#).

## Installing the integrated storage controller card

1. Ensure that you read the [Safety instructions](#).
2. Follow the procedure listed in [Before working inside your system](#).
3. Remove the cooling shroud.
4. Remove the expansion-card riser 1.
5. Keep the #2 Phillips screwdriver handy.

**CAUTION:** Many repairs may only be done by a certified service technician. You should only perform troubleshooting and simple repairs as authorized in your product documentation, or as directed by the online or telephone service and support team. Damage due to servicing that is not authorized by Dell is not covered by your warranty. Read and follow the safety instructions that came with the product.

1. Align the end of the integrated storage-controller card opposite the connector with the integrated storage-controller card holder.



2. Lower the connector side of the integrated storage-controller card into the integrated storage-controller card connector on the system board.  
Ensure that the tabs on the system board align with the screw holes on the integrated storage-controller card.
  3. Align the screws on the integrated storage-controller card cable with the screw holes on the connector.
  4. Tighten the screws to secure the integrated storage-controller card cable with the integrated storage-controller card connector on the system board.
1. Replace the expansion-card riser 1.
  2. Replace the cooling shroud.
  3. Follow the procedure listed in [After working inside your system](#).

## Network daughter card

### Removing the network daughter card

1. Ensure that you read the [Safety instructions](#).
2. Follow the procedure listed in [Before working inside your system](#).
3. If installed, remove expansion card(s) from the expansion-card riser 2 and 3.
4. Keep the #1 Phillips screwdriver handy.

 **CAUTION: Many repairs may only be done by a certified service technician. You should only perform troubleshooting and simple repairs as authorized in your product documentation, or as directed by the online or telephone service and support team. Damage due to servicing that is not authorized by Dell is not covered by your warranty. Read and follow the safety instructions that came with the product.**

1. Using a #1 Phillips screwdriver, loosen the captive screws that secure the network daughter card to the system board.
2. Hold the network daughter card by the edges on either side of the touch point and lift the card to remove it from the connector on the system board.
3. Slide the network daughter card away from the back of the system until the Ethernet connectors are clear of the slot in the back panel.
4. Lift the network daughter card out of the chassis.

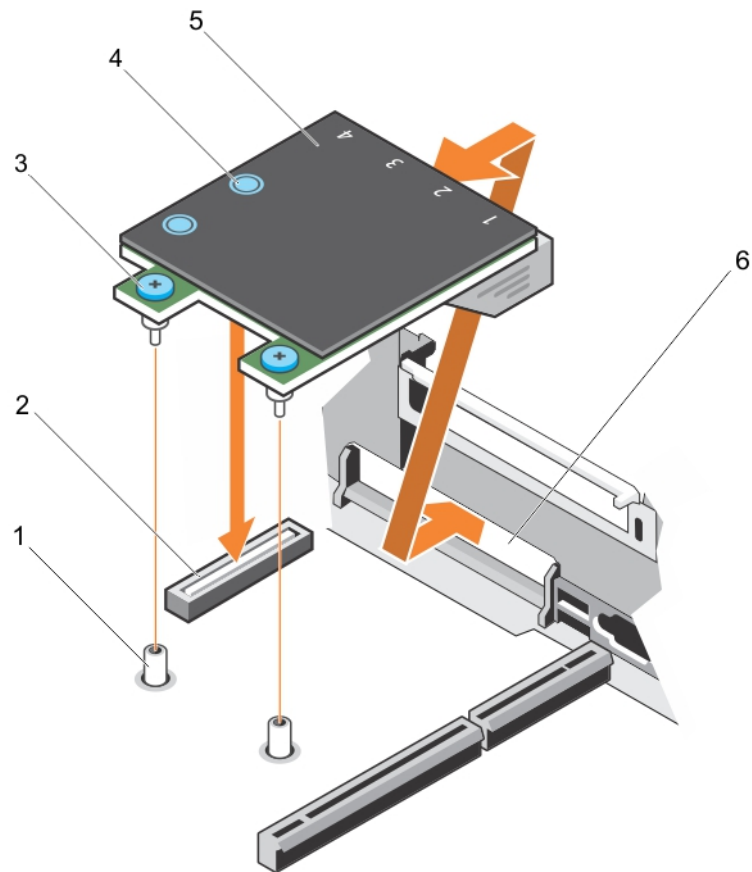

**Figure 34. Removing and installing the Network Daughter Card (NDC)**

- |                             |  |
|-----------------------------|--|
| 1. captive screw socket (2) | 2. connector on the system board           |
| 3. captive screw (2)        | 4. touch point (2)                         |
| 5. network daughter card    | 6. back panel slot for Ethernet connectors |

1. Replace the network daughter card.
2. Follow the procedure listed in [After working inside your system](#).

To see a video on how to remove & install the network daughter card, scan this QR code, or click here: <http://www.Dell.com/QRL/Workstation/R7910/NDC>



## Installing the network daughter card

1. Ensure that you read the [Safety instructions](#).
2. Follow the procedure listed in [Before working inside your system](#).
3. If applicable, remove the expansion card(s) in the expansion-card riser 2.
4. Keep the #1 Phillips screwdriver handy.

**CAUTION:** Many repairs may only be done by a certified service technician. You should only perform troubleshooting and simple repairs as authorized in your product documentation, or as directed by the online or telephone service and support team. Damage due to servicing that is not authorized by Dell is not covered by your warranty. Read and follow the safety instructions that came with the product.

1. Angle the card so that the Ethernet connectors fit through the slot in the back panel.
  2. Align the captive screws on the card with the captive screw sockets on the system board.
  3. Press the touch points on the card until the card connector is firmly seated on the system board connector.
  4. Using a #1 Phillips screwdriver, tighten the captive screws to secure the network daughter card to the system board.
1. If applicable, install the expansion card(s) in the expansion-card riser 2.
  2. Follow the procedure listed in [After working inside your system](#)

To see a video on how to remove & install the network daughter card, scan this QR code, or click here: <http://www.Dell.com/QRL/Workstation/R7910/NDC>



## Heat sink and processor

Use the following procedures when:

- Installing an additional processor.
- Replacing a processor.

**NOTE:** To ensure proper system cooling, install a processor blank in any empty processor socket.

## Removing a processor

**CAUTION:** Many repairs may only be done by a certified service technician. You should only perform troubleshooting and simple repairs as authorized in your product documentation, or as directed by the online or telephone service and support team. Damage due to servicing that is not authorized by Dell is not covered by your warranty. Read and follow the safety instructions that came with the product.

**NOTE:** To ensure proper system cooling, you must install a processor blank in any empty processor socket.

1. Ensure that you read the [Safety instructions](#).
2. Keep the #2 Phillips screwdriver handy.
3. If you are upgrading your system, download the latest system BIOS version from [dell.com/support](http://dell.com/support) and follow the instructions included in the compressed download file to install the update on your system.

**NOTE:** You can update the system BIOS using the Lifecycle Controller.

4. Follow the procedure listed in [Before working inside your system](#)
5. If installed, remove the full-length PCIe card(s).
6. Remove the cooling shroud.

**NOTE:** The heat sink and processor are hot to the touch for some time after the system has been powered down. Allow the heat sink and processor to cool before handling them.

**CAUTION:** Never remove the heat sink from a processor unless you intend to remove the processor. The heat sink is necessary to maintain proper thermal conditions.

1. To remove the heat sink:

- a) Loosen one of the screws that secure the heat sink to the system board.  
Wait 30 seconds for the heat sink to loosen from the processor.
- b) Remove the screw diagonally opposite the screw you first removed.
- c) Repeat the procedure for the remaining two screws.
- d) Remove the heat sink.

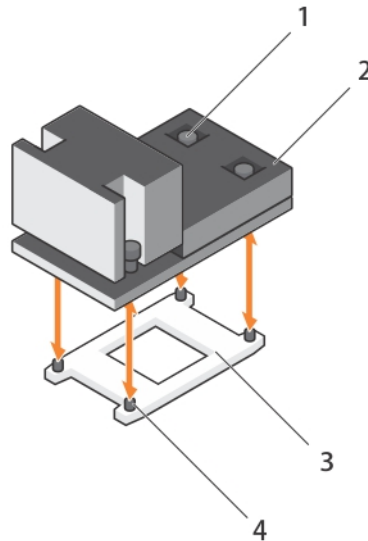

**Figure 35. Removing and installing a processor heat sink**

- |                      |              |
|----------------------|--------------|
| 1. captive screw (4) | 2. heat sink |
| 3. processor socket  | 4. slot (4)  |

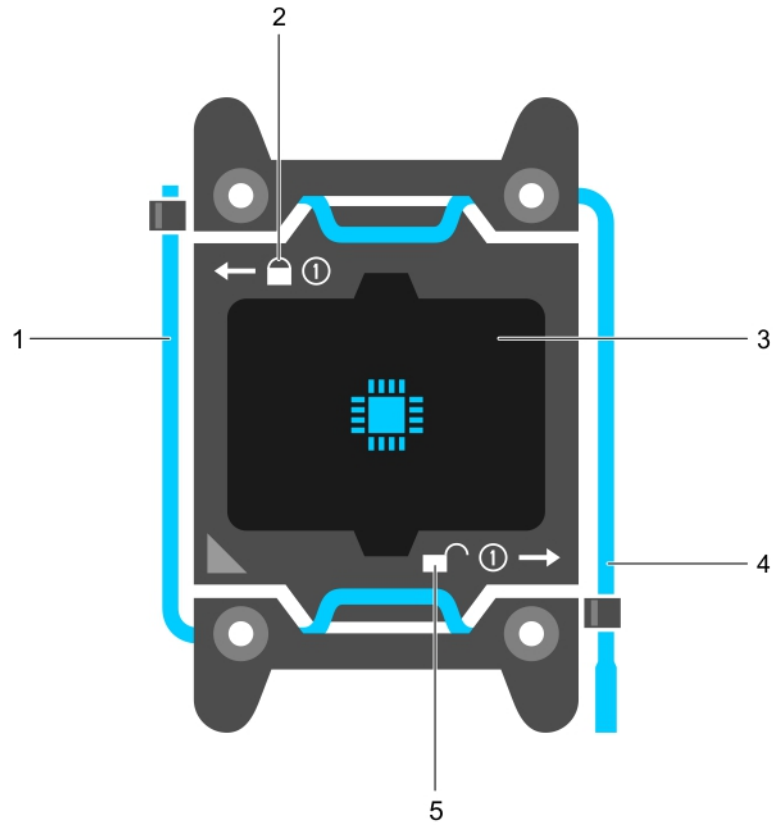

**CAUTION:** The processor is held in its socket under strong pressure. Be aware that the release lever can spring up suddenly if not firmly grasped.

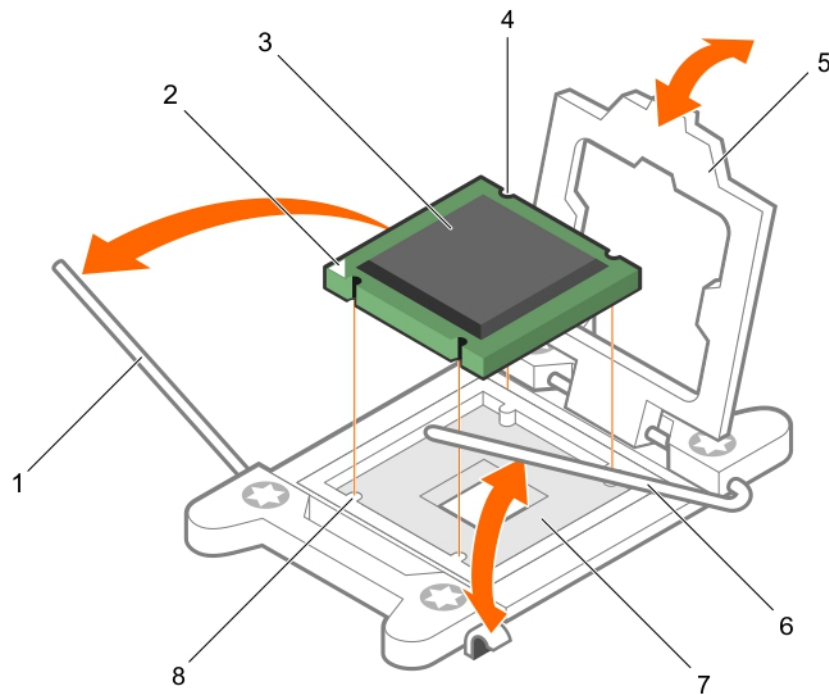

**Figure 36. Processor shield**

- |  |   |
|--|---|
| 1. <i>close first</i> socket release lever | 2. lock icon                              |
| 3. processor                               | 4. <i>open first</i> socket release lever |
| 5. unlock icon                             |   |

2. To remove the processor:

- a) Release the *open first* socket-lever near the unlock icon  by pushing the lever down and out from under the tab.
- b) Similarly, release the *close first* socket-release lever near the lock icon  by pushing the lever down and out from under the tab. Rotate the lever 90 degrees upward.
- c) Lower the *open first* socket-release lever to lift the processor shield.



**Figure 37. Removing and installing a processor**

- |                                     |                                    |
|-------------------------------------|------------------------------------|
| 1. close first socket-release lever | 2. pin-1 indicator of processor    |
| 3. processor                        | 4. slot (4)                        |
| 5. processor shield                 | 6. open first socket-release lever |
| 7. socket                           | 8. socket keys (4)                 |

d) Hold the tab on the processor shield and rotate the processor shield upward until the *open first* socket-release lever lifts up.

**CAUTION:** The socket pins are fragile and can be permanently damaged. Be careful not to bend the pins in the socket when removing the processor out of the socket.

e) Lift the processor out of the socket and leave the *open first* socket-release lever up.

**NOTE:** If you are permanently removing the processor, you must install a socket protective cap in the vacant socket to protect the socket pins and keep the socket free of dust.

**NOTE:** After removing the processor, place it in an anti-static container for reuse, return, or temporary storage. Do not touch the bottom of the processor. Touch only the side edges of the processor.

## Installing a processor

**CAUTION:** Many repairs may only be done by a certified service technician. You should only perform troubleshooting and simple repairs as authorized in your product documentation, or as directed by the online or telephone service and support team. Damage due to servicing that is not authorized by Dell is not covered by your warranty. Read and follow the safety instructions that came with the product.

1. Ensure that you read the [Safety instructions](#).
2. Keep the #2 Phillips screwdriver handy.
3. If you are upgrading your system, download the latest system BIOS version from [dell.com/support](http://dell.com/support) and follow the instructions included in the compressed download file to install the update on your system.

**NOTE:** You can update the system BIOS using the Lifecycle Controller.

4. Follow the procedure listed in [Before working inside your system](#).
5. If installed, remove the full-length PCIe card.

6. Remove the cooling shroud.

 **NOTE: The heat sink and processor are hot to the touch for some time after the system has been powered down. Allow the heat sink and processor to cool before handling them.**

 **CAUTION: Never remove the heat sink from a processor unless you intend to remove the processor. The heat sink is necessary to maintain proper thermal conditions.**

 **NOTE: If you are installing a single processor, it must be installed in socket CPU1.**

1. Unpack the new processor.

If the processor has previously been used in a system, remove any remaining thermal grease from the processor using a lint-free cloth.

2. Locate the processor socket.

3. If applicable, remove the socket protective cap.

4. Release the *open first* socket-release lever near the unlock icon  by pushing the lever down and out from under the tab.

5. Similarly, release the *close first* socket-release lever near the lock icon  by pushing the lever down and out from under the tab. Lift the lever 90 degrees upward.

6. Hold the tab near the lock symbol on the processor shield and lift it up and out of the way.

7. To install the processor in the socket:

 **CAUTION: Positioning the processor incorrectly can permanently damage the system board or the processor. Be careful not to bend the pins in the socket.**

 **CAUTION: While removing or reinstalling the processor, wipe your hands of any contaminants. Contaminants on the processor pins such as thermal grease or oil can damage the processor.**

a) Align the processor with the socket keys.

 **CAUTION: Do not use force to seat the processor. When the processor is positioned correctly, it engages easily into the socket.**

b) Align the pin-1 indicator of the processor with the triangle on the system board. socket socket.

c) Place the processor on the socket such that the slots on the processor align with the socket keys.

 **CAUTION: Do not use force to seat the processor. When the processor is positioned correctly, it engages easily into the socket.**

d) Close the processor shield.

e) Lower the *close first* socket-release lever near the lock icon  and push it under the tab to lock it..

f) Similarly, lower the *open first* socket-release lever near the unlock icon  and push it under the tab to lock it.

8. To install the heat sink:

a) If applicable, remove the existing thermal grease from the heat sink using a clean lint-free cloth.

b) Apply thermal grease on the top of the processor. Use the thermal-grease syringe included with your processor kit.

 **CAUTION: Applying too much thermal grease can result in excess grease coming in contact with and contaminating the processor socket.**

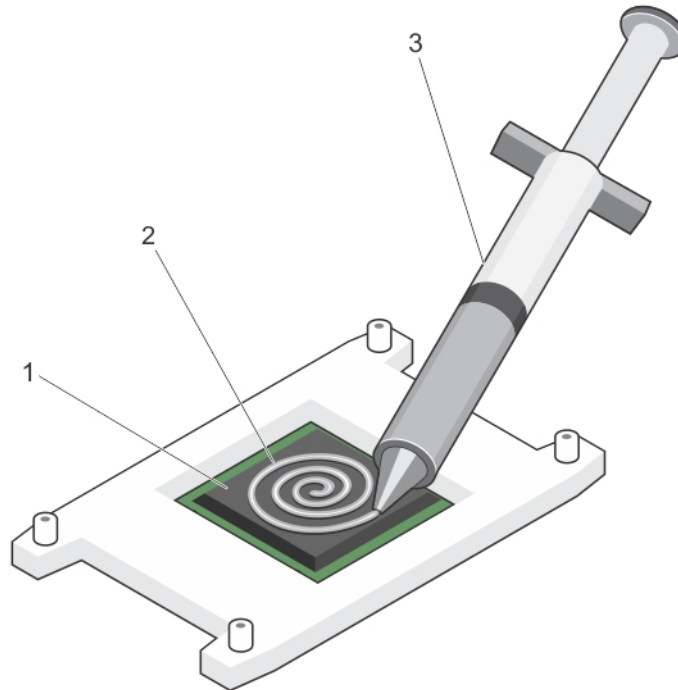

**Figure 38. Applying thermal grease on the top of the processor**

1. processor
2. thermal grease
3. thermal-grease syringe

**NOTE:** The thermal-grease is intended for one-time use only. Dispose of the syringe after you use it.

- c) Place the heat sink onto the processor.
- d) Tighten the four screws to secure the heat sink to the system board.

**NOTE:** Tighten the screws diagonally opposite to each other. Do not over-tighten the heat sink retention screws when installing the heat sink. To prevent over-tightening, tighten the retention screw until resistance is felt, and stop once the screw is seated. The screw tension should be no more than 6 in-lb (6.9 kg-cm).

1. Install the cooling shroud.
2. If applicable, install the PCIe card.
3. If applicable, install the cooling fan assembly.
4. Follow the procedure listed in [After working inside your system](#).
5. While booting, press <F2> to enter the System Setup and check that the processor information matches the new system configuration.
6. Run the system diagnostics to verify that the new processor operates correctly.

## Power supply units

Your system supports:

- Two 1100 W AC power supply modules

**NOTE:** Titanium power supply unit is nominally rated for 200 VAC to 240 VAC input only.

**NOTE:** When two identical PSUs are installed, power supply redundancy (1+1 – with redundancy or 2+0 – without redundancy) is configured in system BIOS. In redundant mode, power is supplied to the system equally from both PSUs when Hot Spare is disabled. When Hot Spare is enabled, one of the PSUs will be put into standby when system utilization is low in order to maximize efficiency.



**NOTE:** For AC power supply units, use only power supply units with the Extended Power Performance (EPP) label on the back. Mixing power supply units from previous generations of servers can result in a power supply unit mismatch condition or failure to power on.

## Hot spare feature

Your system supports the hot spare feature that significantly reduces the power overhead associated with power supply redundancy.

When the hot spare feature is enabled, one of the redundant PSUs is switched to the sleep state. The active PSU supports 100% of the load, thus operating at higher efficiency. The PSU in the sleep state monitors output voltage of the active PSU. If the output voltage of the active PSU drops, the PSU in the sleep state returns to an active output state.

If having both PSUs active is more efficient than having one PSU in the sleep state, the active PSU can also activate the sleeping PSU.

The default PSU settings are as follows:

- If the load on the active PSU is more than 50%, then the redundant PSU is switched to the active state.
- If the load on the active PSU falls below 20%, then the redundant PSU is switched to the sleep state.

You can configure the hot spare feature by using the iDRAC settings. For more information about iDRAC settings, see the Integrated Dell Remote Access Controller User's Guide at [Dell.com/idracmanuals](https://www.dell.com/support/manuals).

## Removing the power supply unit blank

If you are installing a second power supply unit, remove the power supply unit blank in the bay by pulling the blank outward.

**CAUTION:** To ensure proper system cooling, the power supply blank must be installed in the second power supply bay in a non-redundant configuration. Remove the power supply blank only if you are installing a second power supply.

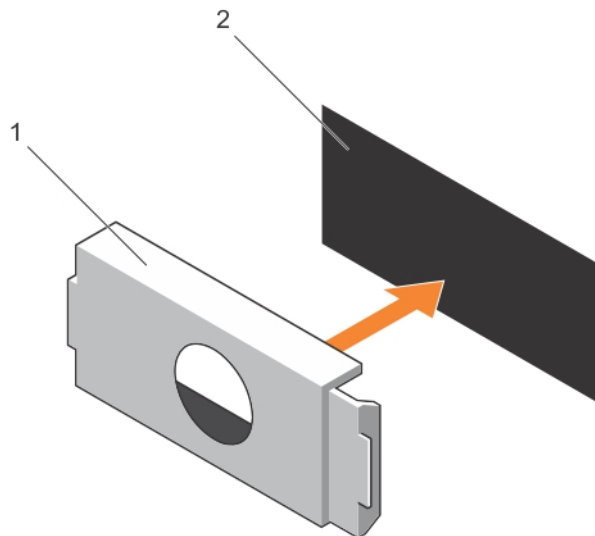

**Figure 39. Removing and installing the power supply blank**

1. power supply blank
2. power supply bay

## Installing the power supply unit blank

Install the power supply unit blank only in the second power supply unit bay.

1. Align the blank with the power supply unit bay.
2. push it into the chassis until it clicks into place.

# Removing an AC power supply unit

**CAUTION:** Many repairs may only be done by a certified service technician. You should only perform troubleshooting and simple repairs as authorized in your product documentation, or as directed by the online or telephone service and support team. Damage due to servicing that is not authorized by Dell is not covered by your warranty. Read and follow the safety instructions that came with the product.

**CAUTION:** The system requires one power supply for normal operation. On power-redundant systems, remove and replace only one power supply at a time in a system that is powered on.

**NOTE:** You may have to unlatch and lift the optional cable management arm if it interferes with power supply removal. For information about the cable management arm, see the system's rack documentation.

1. Disconnect the power cable from the power source and from the power supply unit you intend to remove and remove the cables from the strap.
2. Press the release latch and slide the power supply unit out of the chassis.

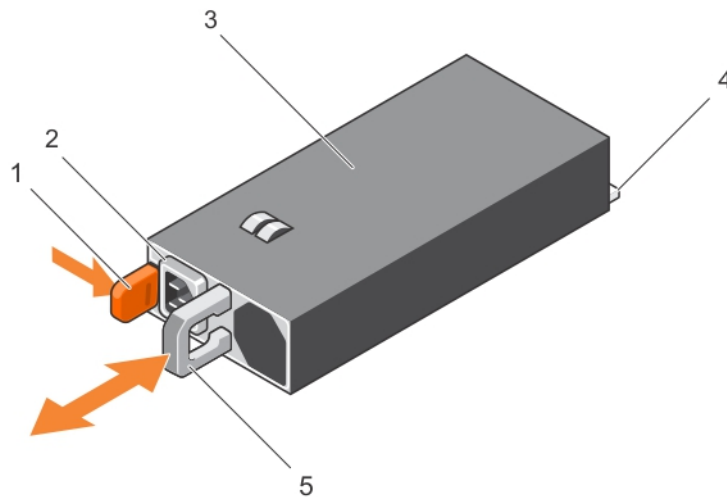

**Figure 40. Removing and installing an AC power supply unit**

- |                             |                                      |
|-----------------------------|--------------------------------------|
| 1. release latch            | 2. power supply unit cable connector |
| 3. power supply unit        | 4. connector                         |
| 5. power supply unit handle |                                      |

## Related video

<http://www.Dell.com/QRL/Server/PER730/PSU>



To see a video on how to remove & install the power supplies, scan this QR code, or click here: <http://www.Dell.com/QRL/Workstation/R7910/PSU>



## Installing an AC power supply unit

**CAUTION:** Many repairs may only be done by a certified service technician. You should only perform troubleshooting and simple repairs as authorized in your product documentation, or as directed by the online or telephone service and support team. Damage due to servicing that is not authorized by Dell is not covered by your warranty. Read and follow the safety instructions that came with the product.

1. Verify that both the power supply units are the same type and have the same maximum output power.

**NOTE:** The maximum output power (shown in watts) is listed on the PSU label.

2. If applicable, remove the power supply unit blank.
3. Slide the new power supply unit into the chassis until the power supply unit is fully seated and the release latch snaps into place.

**NOTE:** If you unlatched the cable management arm, re-latch it. For information about the cable management arm, see the system's rack documentation.

4. Connect the power cable to the power supply unit and plug the cable into a power outlet.

**CAUTION:** When connecting the power cable, secure the cable with the strap.

**NOTE:** When installing, hot-swapping, or hot-adding a new power supply unit, wait for 15 seconds for the system to recognize the power supply unit and determine its status. The power supply redundancy may not occur until discovery is complete. Wait until the new power supply unit is discovered and enabled before you remove the other power supply unit. The power-supply unit status indicator turns green to signify that the power supply unit is functioning properly.

To see a video on how to remove & install the power supplies, scan this QR code, or click here: <http://www.Dell.com/QRL/Workstation/R7910/PSU>



## System battery

### Replacing the system battery

1. Ensure that you read the [Safety instructions](#).
2. Follow the procedure listed in [Before working inside your system](#).
3. Remove the cooling shroud.

**NOTE:** There is a danger of a new battery exploding if it is incorrectly installed. Replace the battery only with the same or equivalent type recommended by the manufacturer. For more information, see the safety information that shipped with your system.

**CAUTION:** Many repairs may only be done by a certified service technician. You should only perform troubleshooting and simple repairs as authorized in your product documentation, or as directed by the online or telephone service and support team. Damage due to servicing that is not authorized by Dell is not covered by your warranty. Read and follow the safety instructions that came with the product.

1. Locate the battery socket.

**CAUTION:** To avoid damage to the battery connector, you must firmly support the connector while installing or removing a battery.

2. Place your finger between the securing tabs at the negative side of the battery connector and lift the battery out of the socket.

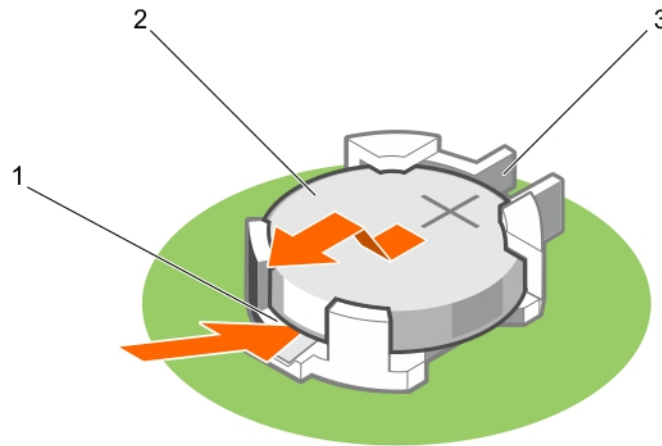

**Figure 41. Removing the system battery**

- a. positive side of the battery connector
  - b. system battery
  - c. negative side of the battery connector
3. To install a new system battery, hold the battery with the "+" facing up and slide it under the securing tabs.
4. Press the battery into the connector until it snaps into place.

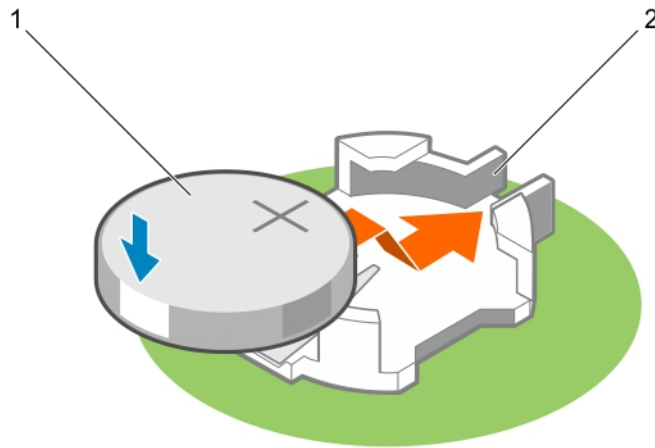

**Figure 42. Installing the system battery**

- a. system battery
- b. positive side of the battery connector

1. Install the cooling shroud.
2. Follow the procedure listed in [After working inside your system](#).
3. While booting, press <F2> to enter the System Setup and ensure the battery is operating properly.
4. Enter the correct time and date in the System Setup **Time** and **Date** fields.
5. Exit the System Setup.

To see a video on how to remove & install the system battery, scan this QR code, or click here: <http://www.Dell.com/QRL/Workstation/R7910/Battery>



## Hard-drive backplane

Depending on your system configuration:

**Precision Rack 7910**      2.5 inch (x8) HDD/SSD

## Removing the hard-drive backplane

1. Ensure that you read the [Safety instructions](#).
2. Follow the procedure listed in [Before working inside your system](#).
3. Remove the cooling shroud.
4. Remove the cooling-fan assembly.
5. Remove all hard drives.

**CAUTION:** Many repairs may only be done by a certified service technician. You should only perform troubleshooting and simple repairs as authorized in your product documentation, or as directed by the online or telephone service and

support team. Damage due to servicing that is not authorized by Dell is not covered by your warranty. Read and follow the safety instructions that came with the product.

**CAUTION:** To prevent damage to the drives and backplane, you must remove the hard drives from the system before removing the backplane.

**CAUTION:** You must note the number of each hard drive and temporarily label them before removal so that you can replace them in the same locations.

1. Disconnect the HHD/SSD data, signal, and power cable(s) from the backplane.
2. Press the release tabs and lift the backplane upward and slide it toward the back of the chassis.

**NOTE:** To prevent damage to the control panel flex cable, unlatch the blocking tab on the connector before removing the flex cable. Do not bend the flex cable at the connector. To unlatch the blocking tab for the x12 backplane, pull the locking tab up. For the x18 and x2 backplanes, rotate the locking tab 90 degrees clockwise.

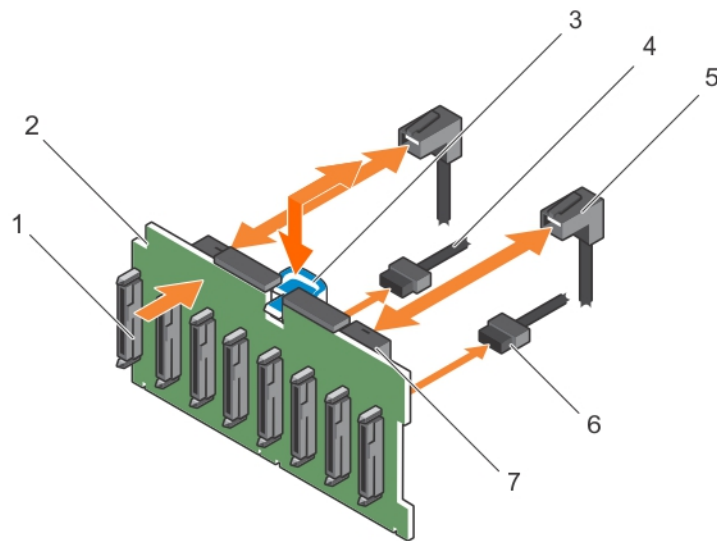

**Figure 43. Removing and installing the 2.5 inch (x8) HHD/SSD backplane—Precision Rack 7910**

- |  |                                 |
|--|---------------------------------|
| 1. hard-drive backplane connectors (8) | 2. left ear control panel cable |
| 3. release tab                         | 4. backplane power cable        |
| 5. SAS cable                           | 6. mini SAS cable connector     |

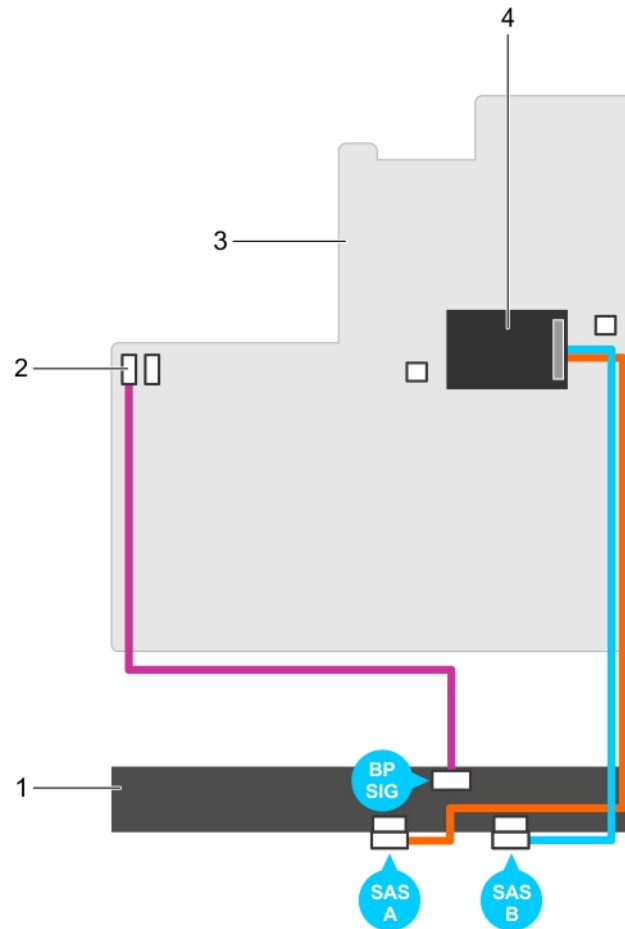

- |                         |                                       |
|-------------------------|---------------------------------------|
| 1. hard-drive backplane | 2. backplane signal connector 1       |
| 3. system board         | 4. integrated storage controller card |

## Installing the hard-drive backplane

1. Ensure that you read the [Safety instructions](#).
2. Follow the procedure listed in [Before working inside your system](#).

**CAUTION:** Many repairs may only be done by a certified service technician. You should only perform troubleshooting and simple repairs as authorized in your product documentation, or as directed by the online or telephone service and support team. Damage due to servicing that is not authorized by Dell is not covered by your warranty. Read and follow the safety instructions that came with the product.

**CAUTION:** To prevent damage to the control panel flex cable, do not to bend the control panel flex cable after it is inserted into the connector.

1. Use the hooks on the chassis as guides to align the hard-drive backplane.
2. Slide down the hard-drive backplane until the release tabs snap into place.
3. Connect the HHD/SSD data, signal, and power cable to the backplane.

1. Replace the cooling-fan assembly.
2. Replace the cooling shroud.
3. Install the hard drives in their original locations.
4. Follow the procedure listed in [After working inside your system](#).

# Control panel assembly

## Removing the control panel

1. Ensure that you read the [Safety instructions](#).
2. Follow the procedure listed in [Before working inside your system](#).

**CAUTION:** Many repairs may only be done by a certified service technician. You should only perform troubleshooting and simple repairs as authorized in your product documentation, or as directed by the online or telephone service and support team. Damage due to servicing that is not authorized by Dell is not covered by your warranty. Read and follow the safety instructions that came with the product.

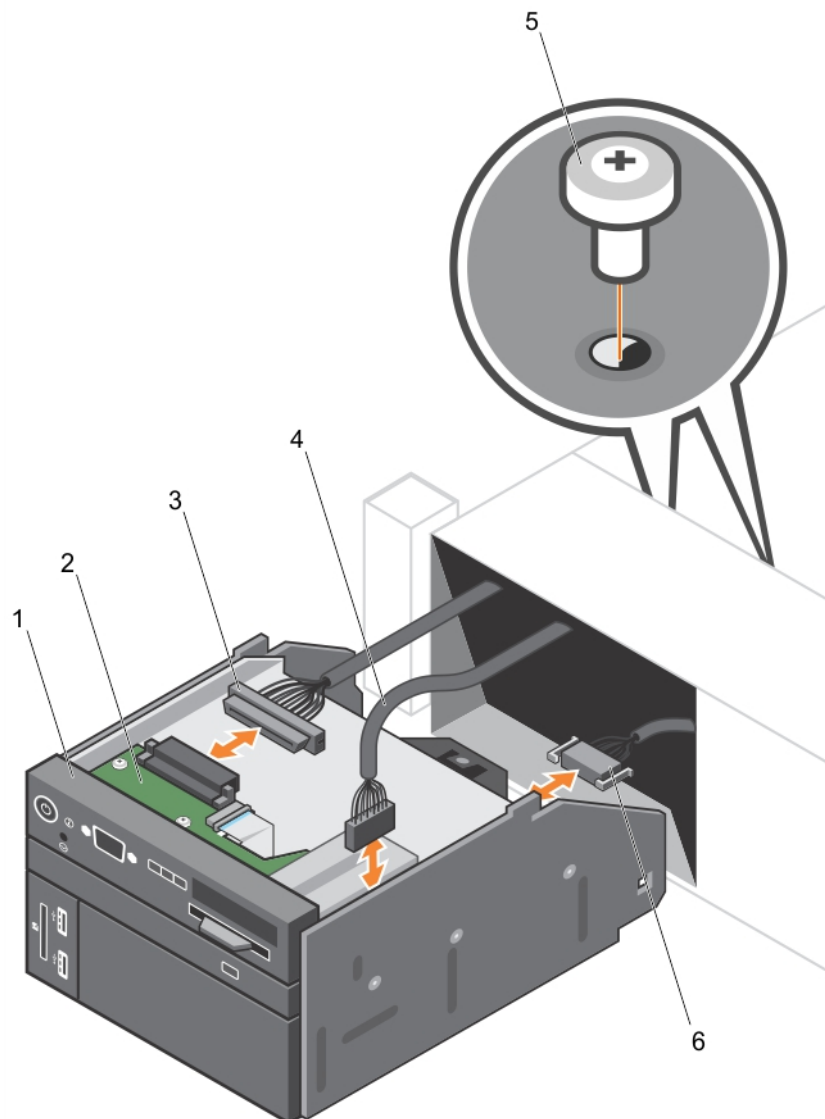

**Figure 44. Removing and installing the control panel—2.5 inch hard-drive system**

- |                                  |                                 |
|----------------------------------|---------------------------------|
| 1. control panel                 | 2. control-panel board          |
| 3. control-panel connector cable | 4. USB connector cable          |
| 5. screw (2)                     | 6. vFlash media connector cable |

1. Locate and press the tabs on the information tag.
2. Push the information tag out of the slot to remove it from the control panel.



**NOTE:** Retain the information tag for replacement in the new control panel.

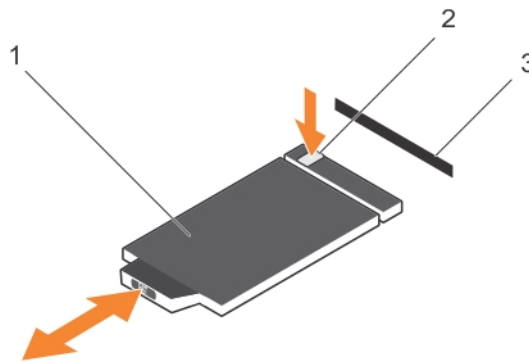

**Figure 45. Removing and installing the information tag**

- a. information tag
  - b. tab
  - c. slot
3. Remove the retaining screw that secures the control panel to the chassis.
  4. Push the control panel out of the chassis.
  5. Slide the control panel into the chassis and tighten the screw.

## Installing the control panel

1. Ensure that you read the [Safety instructions](#).

**CAUTION:** Many repairs may only be done by a certified service technician. You should only perform troubleshooting and simple repairs as authorized in your product documentation, or as directed by the online or telephone service and support team. Damage due to servicing that is not authorized by Dell is not covered by your warranty. Read and follow the safety instructions that came with the product.

1. Replace the blank information tag in the new control panel with the information tag retained from the old control panel.

**NOTE:** Information tag lists system information such as Service Tag, NIC, MAC address, and so on.

2. To install the information tag, push the information tag into the control-panel slot.
3. Connect all the applicable cables to the control panel.
4. Slide the control panel into the slot in the chassis.

Follow the procedure listed in [After working inside your system](#).

## System board

### Removing the system board

**CAUTION:** Many repairs may only be done by a certified service technician. You should only perform troubleshooting and simple repairs as authorized in your product documentation, or as directed by the online or telephone service and support team. Damage due to servicing that is not authorized by Dell is not covered by your warranty. Read and follow the safety instructions that came with the product.

**CAUTION:** If you are using the Trusted Platform Module (TPM) with an encryption key, you may be prompted to create a recovery key during program or System Setup. Be sure to create and safely store this recovery key. If you replace this

system board, you must supply the recovery key when you restart your system or program before you can access the encrypted data on your hard drives.

**CAUTION:** Do not attempt to remove the TPM plug-in module from the motherboard. Once the TPM plug-in module is installed, it is cryptographically bound to that specific motherboard. Any attempt to remove an installed TPM plug-in module breaks the cryptographic binding, and it cannot be re-installed or installed on another motherboard.

1. Ensure that you read the [Safety instructions](#).
2. Follow the procedure listed in [Before working inside your system](#).
3. Remove the following:
  - a. cooling shroud
  - b. cooling-fan assembly
  - c. power supply unit(s)
  - d. remove all PCIe cards installed in Riser 2 and Riser 3
  - e. integrated storage controller card
  - f. internal dual SD module
  - g. internal USB key (if installed)
  - h. PCIe card holder
  - i. cable retention bracket
  - j. heat sink(s)/heat-sink blank(s)
  - k. processors(s)/processor blank(s)

**CAUTION:** To prevent damage to the processor pins when replacing a faulty system board, ensure that you cover the processor socket with the processor protective cap.

- l. memory modules and memory module blanks
  - m. network daughter card
1. Disconnect the mini SAS cable from the system board.
  2. Disconnect all cables from the system board.

**CAUTION:** Take care not to damage the system identification button while removing the system board from the chassis.

**CAUTION:** Do not lift the system board by holding a memory module, processor, or other components.

3. Hold the system-board holder, lift the blue release pin, lift the system board and slide it toward the front of the chassis. Sliding the system board toward the front of the chassis disengages the connectors from the back of the chassis slots.
4. Lift the system board out of the chassis.

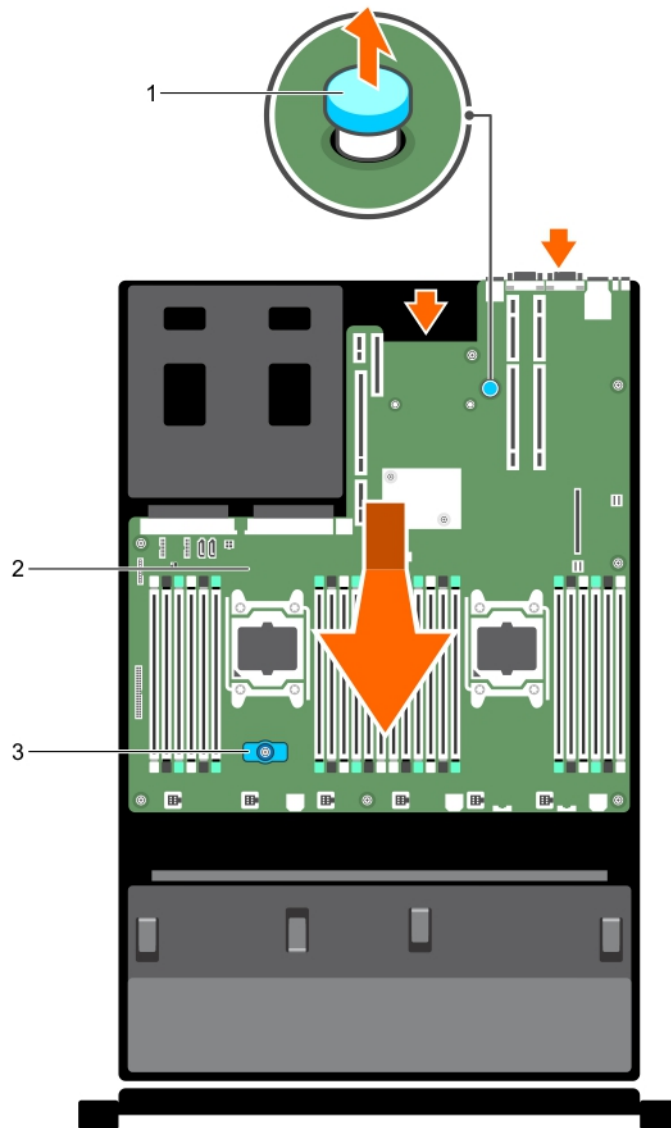

**Figure 46. Removing and installing the system board**

- a. release pin
- b. system board
- c. system-board holder

1. Replace the system board.
2. Follow the procedure listed in [After working inside your system](#).

To see a video on how to remove & install the system board, scan this QR code, or click here: <http://www.Dell.com/QRL/Workstation/R7910/MOBO>



# Installing the system board

1. Ensure that you read the [Safety instructions](#).
2. Follow the procedure listed in [Before working inside your system](#).

**CAUTION:** Many repairs may only be done by a certified service technician. You should only perform troubleshooting and simple repairs as authorized in your product documentation, or as directed by the online or telephone service and support team. Damage due to servicing that is not authorized by Dell is not covered by your warranty. Read and follow the safety instructions that came with the product.

1. Unpack the new system board assembly.

**CAUTION:** Do not lift the system board by holding a memory module, processor, or other components.

**CAUTION:** Take care not to damage the system identification button while placing the system board into the chassis.

2. Hold the touch points and lower the system board into the chassis.
3. Push the system board toward the back of the chassis until the board clicks into place.

1. Install the Trusted Platform Module (TPM)..

**NOTE:** The TPM plug-in module is attached to the motherboard and cannot be removed. A replacement TPM plug-in module will be provided for all motherboard replacements where a TPM plug-in module was installed.

2. Reconnect all cables to the system board:

- a. cable retention bracket
- b. PCIe card holder
- c. integrated storage controller card
- d. internal USB key (if applicable)
- e. internal dual SD module
- f. install PCIe cards in risers
- g. heat sink(s)/heat-sink blank(s) and processors(s)/processor blank(s)
- h. memory modules and memory module blanks
- i. network daughter card
- j. cooling-fan assembly
- k. cooling shroud
- l. power supply unit(s)

**NOTE:** Ensure that the cables inside the system are routed along the chassis wall and secured using the cable securing bracket.

3. Follow the procedure listed in [After working inside your system](#).
4. Import your new or existing iDRAC Enterprise license. For more information, see Integrated Dell Remote Access Controller User's Guide, at [dell.com/esmmanuals](http://dell.com/esmmanuals).
5. Ensure that you:
  - a. Use the **Easy Restore** feature to restore the service tag.
  - b. If the service tag is not backed up in the backup flash device, enter the system service tag manually.
  - c. Update the BIOS and iDRAC versions.
  - d. Re-enable the Trusted Platform Module (TPM).

To see a video on how to remove & install the system board, scan this QR code, or click here: <http://www.Dell.com/QRL/Workstation/R7910/MOBO>



# Entering the system service tag by using System Setup

If Easy Restore fails to restore the service tag, use System Setup to enter the service tag.

1. Turn on the system.
2. Press F2 to enter System Setup.
3. Click **Service Tag Settings**.
4. Enter the service tag.



**NOTE:** You can enter the service tag only when the service tag field is empty. Ensure that you enter the correct service tag. After the service tag is entered, it cannot be updated or changed.

5. Click **Ok**.
6. Import your new or existing iDRAC Enterprise license.

For more information, see the Integrated Dell Remote Access Controller User's Guide, at [Dell.com/idracmanuals](http://Dell.com/idracmanuals).

# Restoring the Service Tag by using the Easy Restore feature

The Easy Restore feature enables you to restore your system's Service Tag, license, UEFI configuration, and the system configuration data after replacing the system board. All data is automatically backed up in a backup flash device. If BIOS detects a new system board and the Service Tag in the backup flash device, BIOS prompts the user to restore the backup information.

1. Turn on the system.  
If BIOS detects a new system board, and if the Service Tag is present in the backup flash device, BIOS displays the Service Tag, the status of the license, and the **UEFI Diagnostics** version.
2. Perform one of the following steps:
  - Press **Y** to restore the Service Tag, license, and diagnostics information.
  - Press **N** to navigate to the Dell Lifecycle Controller based restore options.
  - Press F10 to restore data from a previously created **Hardware Server Profile**.

After the restore process is complete, BIOS prompts to restore the system configuration data.

3. Perform one of the following steps:
  - Press **Y** to restore the system configuration data.
  - Press **N** to use the default configuration settings.

After the restore process is complete, the system restarts.

# Updating the BIOS version

1. Copy the BIOS update file on a USB device.
2. Plug in the USB device into any of the USB ports on your system.
3. Turn on your system.
4. While booting, press <F11> to enter the **Boot Manager**.
5. Go to **System Utilities** → **BIOS Update File Explorer**, and select the plugged in USB device.
6. From the **BIOS Update File Explorer**, select the BIOS update file.  
The **BIOS Update Utility** with the current and new version of BIOS is displayed.
7. Select **Continue BIOS Update** to install the BIOS update.

# Re-enabling the TPM for TXT users

1. While booting your system, press F2 to enter System Setup.
2. In the **System Setup Main Menu**, click **System BIOS** → **System Security Settings**.
3. In the **TPM Security** option, select **On with Pre-boot Measurements**.
4. In the **TPM Command** option, select **Activate**.
5. Save the settings.

6. Restart your system.
7. Enter System Setup again.
8. In the **System Setup Main Menu**, click **System BIOS** → **System Security Settings**.
9. In the **Intel TXT** option, select **On**.

# Troubleshooting your system

## Safety first—for you and your system

**CAUTION:** Many repairs may only be done by a certified service technician. You should only perform troubleshooting and simple repairs as authorized in your product documentation, or as directed by the online or telephone service and support team. Damage due to servicing that is not authorized by Dell is not covered by your warranty. Read and follow the safety instructions that came with the product.

### Topics:

- Troubleshooting system startup failure
- Troubleshooting external connections
- Troubleshooting the video subsystem
- Troubleshooting a USB device
- Troubleshooting iDRAC Direct (USB XML configuration)
- Troubleshooting iDRAC Direct (laptop connection)
- Troubleshooting a serial I/O device
- Troubleshooting a NIC
- Troubleshooting a wet system
- Troubleshooting a damaged system
- Troubleshooting the system battery
- Troubleshooting power supply units
- Troubleshooting cooling problems
- Troubleshooting cooling fans
- Troubleshooting system memory
- Troubleshooting an internal USB key
- Troubleshooting an SD card
- Troubleshooting an optical drive
- Troubleshooting a hard drive
- Troubleshooting a storage controller
- Troubleshooting expansion cards
- Troubleshooting processors
- Error Messages
- System messages

## Troubleshooting system startup failure

If you boot the system to the BIOS boot mode after installing an operating system from the UEFI Boot Manager, the system stops responding. To avoid this issue, you must boot to the same boot mode in which you installed the operating system.

For all other startup issues, note the system messages that appear on the screen.

## Troubleshooting external connections

Before troubleshooting any external devices, ensure that all external cables are securely attached to the external connectors on your system before troubleshooting any external devices.

## Troubleshooting the video subsystem

1. Check the system and power connections to the monitor.

2. Check the video interface cabling from the system to the monitor.
3. Run the appropriate diagnostic test.

## Troubleshooting a USB device

Use the following steps to troubleshoot a USB keyboard/mouse. For other USB devices, go to step 7.

1. Disconnect the keyboard and mouse cables from the system and reconnect them.
2. If the problem persists, connect the keyboard/mouse to the USB port(s) on the opposite side of the system.
3. If the problem is resolved, restart the system, enter the System Setup, and check if the non-functioning USB ports are enabled. Check if USB 3.0 is enabled in System Setup. If enabled, disable it and see if the issue is resolved (older operating systems may not support USB 3.0).
4. In the **IDRAC Settings Utility**, ensure the **USB Management Port Mode** is configured as **Automatic** or **Standard OS Use**.
5. Replace the keyboard/mouse with a working keyboard/mouse. If the problem is not resolved, proceed to the next step to begin troubleshooting other USB devices attached to the system.
6. Power down all attached USB devices and disconnect them from the system.
7. Reboot the system and, if your keyboard is functioning, enter the System Setup.
8. Verify that all USB ports are enabled on the **Integrated Devices** screen, in the System Setup options.
9. Check if USB 3.0 is enabled in System Setup. If it is enabled, disable it and restart your system. If your keyboard is not functioning, you can also use remote access.
10. If the system is not accessible, reset the NVRAM\_CLR jumper inside your system and restore the BIOS to the default settings.
11. In the **IDRAC Settings Utility**, ensure the **USB Management Port Mode** is configured as **Automatic** or **Standard OS Use**.
12. Reconnect and power on each USB device one at a time.
13. If a USB device causes the same problem, power down the device, replace the USB cable with a known good cable, and power up the device.

## Troubleshooting iDRAC Direct (USB XML configuration)

For information on USB storage device and server configuration, see the Integrated Dell Remote Access Controller User's Guide at [dell.com/esmanuals](http://dell.com/esmanuals).

1. Ensure your USB storage device is connect to the front USB Management Port, identified by  icon.
2. Ensure your USB storage device is configured with an NTFS or a FAT32 file system with only one partition.
3. Verify that the USB storage device is configured correctly. For more information on configuring the USB storage device, see the Integrated Dell Remote Access Controller User's Guide at [dell.com/esmanuals](http://dell.com/esmanuals).
4. In the **IDRAC Settings Utility**, ensure the **USB Management Port Mode** is configured as **Automatic** or **iDRAC Direct Only**.
5. Make sure the **iDRAC Managed: USB XML Configuration** option is either **Enabled** or **Enabled only when the server has default credential settings**.
6. Remove and re-insert the USB storage device.
7. If import operation does not work, try with a different USB storage device.

## Troubleshooting iDRAC Direct (laptop connection)

For information on USB laptop connection and server configuration, see the Integrated Dell Remote Access Controller User's Guide at [dell.com/esmanuals](http://dell.com/esmanuals).

1. Make sure your laptop is connected to the front USB Management Port, identified by  icon with a USB Type A/A cable.
2. In the **IDRAC Settings Utility**, ensure the **USB Management Port Mode** is configured as **Automatic** or **iDRAC Direct Only**.
3. If the laptop is running the Windows operating system, ensure the iDRAC Virtual USB NIC device driver is installed.
4. If the driver is installed, ensure you are not connected to any network through WiFi or cabled ethernet as iDRAC Direct uses a non-routable address.



# Troubleshooting a serial I/O device

1. Turn off the system and any peripheral devices connected to the serial port.
2. Swap the serial interface cable with a working cable, and turn on the system and the serial device.  
If the problem is resolved, replace the interface cable with a known good cable.
3. Turn off the system and the serial device, and swap the serial device with a comparable device.
4. Turn on the system and the serial device.

# Troubleshooting a NIC

1. Run the appropriate diagnostic test. See [Using System Diagnostics](#) for available diagnostic tests.
2. Reboot the system and check for any system messages pertaining to the NIC controller.
3. Check the appropriate indicator on the NIC connector:
  - If the link indicator does not light, check all cable connections.
  - If the activity indicator does not light, the network driver files might be damaged or missing.  
Remove and reinstall the drivers if applicable. See the NIC's documentation.
  - If applicable, change the autonegotiation setting.
  - Use another connector on the switch or hub.
4. Ensure that the appropriate drivers are installed and the protocols are bound. See the NIC's documentation.
5. Enter the System Setup and confirm that the NIC ports are enabled on the **Integrated Devices** screen.
6. Ensure that the NICs, hubs, and switches on the network are all set to the same data transmission speed and duplex. See the documentation for each network device.
7. Ensure that all network cables are of the proper type and do not exceed the maximum length.

# Troubleshooting a wet system

**⚠ CAUTION: Many repairs may only be done by a certified service technician. You should only perform troubleshooting and simple repairs as authorized in your product documentation, or as directed by the online or telephone service and support team. Damage due to servicing that is not authorized by Dell is not covered by your warranty. Read and follow the safety instructions that came with the product.**

1. Turn off the system and attached peripherals, and disconnect the system from the electrical outlet.
2. Remove the system cover.
3. Remove the following components from the system:
  - hard drives
  - hard-drive backplane
  - USB memory key
  - hard-drive tray
  - cooling shroud
  - expansion-card risers (if present)
  - expansion cards
  - power supply unit(s)
  - cooling-fan assembly (if present)
  - cooling fans
  - processor(s) and heat sink(s)
  - memory modules
4. Let the system dry thoroughly for at least 24 hours.
5. Reinstall the components you removed in step 3.
6. Install the system cover.
7. Turn on the system and attached peripherals.
8. Run the appropriate diagnostic test. For more information, see [Using System Diagnostics](#).

# Troubleshooting a damaged system

**CAUTION:** Many repairs may only be done by a certified service technician. You should only perform troubleshooting and simple repairs as authorized in your product documentation, or as directed by the online or telephone service and support team. Damage due to servicing that is not authorized by Dell is not covered by your warranty. Read and follow the safety instructions that came with the product.

1. Turn off the system and attached peripherals, and disconnect the system from the electrical outlet.
2. Remove the system cover.
3. Ensure that the following components are properly installed:
  - Cooling shroud
  - Expansion-card risers (if present)
  - Expansion cards
  - Power supply(s)
  - Cooling-fan assembly (if present)
  - Cooling fans
  - Processor(s) and heat sink(s)
  - Memory modules
  - Hard-drive carriers
  - Hard-drive backplane
4. Ensure that all cables are properly connected.
5. Install the system cover.
6. Run the appropriate diagnostic test. For more information, see [Using System Diagnostics](#).

# Troubleshooting the system battery

**CAUTION:** Many repairs may only be done by a certified service technician. You should only perform troubleshooting and simple repairs as authorized in your product documentation, or as directed by the online or telephone service and support team. Damage due to servicing that is not authorized by Dell is not covered by your warranty. Read and follow the safety instructions that came with the product.

**NOTE:** If the system is turned off for long periods of time (for weeks or months), the NVRAM may lose its system configuration information. This situation is caused by a defective battery.

**NOTE:** Some software may cause the system time to speed up or slow down. If the system seems to operate normally except for the time kept in the System Setup, the problem may be caused by software rather than by a defective battery.

1. Re-enter the time and date in the System Setup.
2. Turn off the system and disconnect it from the electrical outlet for at least one hour.
3. Reconnect the system to the electrical outlet and turn on the system.
4. Enter the System Setup.

If the date and time are not correct in the System Setup, check the SEL for system battery messages.

# Troubleshooting power supply units

**CAUTION:** Many repairs may only be done by a certified service technician. You should only perform troubleshooting and simple repairs as authorized in your product documentation, or as directed by the online or telephone service and support team. Damage due to servicing that is not authorized by Dell is not covered by your warranty. Read and follow the safety instructions that came with the product.

## Power source problems

1. Press the power button to ensure that your system is turned on. If the power indicator does not light up when the power button is pressed, press the power-on button firmly.
2. Plug in another working device to ensure that the power outlet is not faulty
3. Ensure that no loose connections exist.  
For example, loose power cables.
4. Ensure that the power source meets applicable standards.
5. Ensure that there are no short circuits.
6. Have a qualified electrician check the line voltage to ensure that it meets the required specifications.

## Power supply unit problems

1. Ensure that no loose connections exist.  
For example, loose power cables.
2. Ensure that the power supply handle/LED indicates that the power supply is working properly.
3. If you have recently upgraded your system, ensure that the power supply unit has enough power to support the new system.
4. If you have a redundant power supply configuration, ensure that both the power supply units are of the same type and wattage.
5. Ensure that you use only power supply units with the Extended Power Performance (EPP) label on the back.
6. Reset the power supply unit.

 **NOTE:** After installing a power supply unit, allow several seconds for the system to recognize the power supply unit and determine if it is working properly.

## Troubleshooting cooling problems

 **CAUTION:** Many repairs may only be done by a certified service technician. You should only perform troubleshooting and simple repairs as authorized in your product documentation, or as directed by the online or telephone service and support team. Damage due to servicing that is not authorized by Dell is not covered by your warranty. Read and follow the safety instructions that came with the product.

Ensure that the following conditions exist:

- System cover, cooling shroud, EMI filler panel, or back-filler bracket is not removed.
- Ambient temperature is not higher than the specified ambient temperature.
- External airflow is not obstructed.
- A cooling fan is not removed or has not failed.
- The expansion card installation guidelines have been followed.

Additional cooling can be added by one of the following methods:

From the iDRAC Web GUI:

1. Click **Hardware > Fans > Setup**.
2. From the **Fan Speed Offset** drop-down list, select the cooling level needed or set the minimum fan speed to a custom value.

From F2 System Setup:

1. Select **iDRAC Settings > Thermal**, and set a higher fan speed from the fan speed offset or minimum fan speed.

From RACADM commands:

1. Run the command `racadm help system.thermalsettings`

For more information, see the Integrated Dell Remote Access Controller User's Guide at [Dell.com/idracmanuals](https://www.dell.com/idracmanuals).

## Troubleshooting cooling fans

 **CAUTION:** Many repairs may only be done by a certified service technician. You should only perform troubleshooting and simple repairs as authorized in your product documentation, or as directed by the online or telephone service and

**support team. Damage due to servicing that is not authorized by Dell is not covered by your warranty. Read and follow the safety instructions that came with the product.**

**i NOTE:** In the event of a problem with a particular fan, the fan number is referenced by the system's management software, allowing you to easily identify and replace the proper fan by noting the fan numbers on the cooling fan assembly.

1. Remove the system cover.
2. Reset the fan.
3. If the fan functions properly, install the system cover.

## Troubleshooting system memory

**⚠ CAUTION:** Many repairs may only be done by a certified service technician. You should only perform troubleshooting and simple repairs as authorized in your product documentation, or as directed by the online or telephone service and support team. Damage due to servicing that is not authorized by Dell is not covered by your warranty. Read and follow the safety instructions that came with the product.

1. If the system is operational, run the appropriate diagnostic test. See [Using system diagnostics](#) for available diagnostic tests.  
If diagnostics indicate a fault, follow the corrective actions provided by the diagnostic program.
2. If the system is not operational, turn off the system and attached peripherals, and unplug the system from the power source. Wait at least 10 seconds and then reconnect the system to the power source.
3. Turn on the system and attached peripherals and note the messages on the screen.  
If an error message is displayed indicating a fault with a specific memory module, go to step 12.
4. Enter the System Setup and check the system memory setting. Make any changes to the memory settings, if needed.  
If the memory settings match the installed memory but the problem still persists, go to step 12.
5. Turn off the system and attached peripherals, and disconnect the system from the electrical outlet.
6. Remove the system cover.
7. Check the memory channels and ensure that they are populated correctly.

**i NOTE:** See the system event log or system messages for the location of the failed memory module. Reinstall the memory device.

8. Reset the memory modules in their sockets.
9. Install the system.
10. Enter the System Setup and check the system memory setting.  
If the problem is not resolved, proceed with the next step.
11. Remove the system cover.
12. If a diagnostic test or error message indicates a specific memory module as faulty, swap or replace the module with a known good memory module.
13. To troubleshoot an unspecified faulty memory module, replace the memory module in the first DIMM socket with a module of the same type and capacity.  
If an error message is displayed on the screen, this may indicate a problem with the installed DIMM type(s), incorrect DIMM installation, or defective DIMM(s). Follow the on-screen instructions to resolve the problem.
14. Install the system cover.
15. As the system boots, observe any error message that is displayed and the diagnostic indicators on the front of the system.
16. If the memory problem persists, repeat step 12 through step 15 for each memory module installed.

## Troubleshooting an internal USB key

**⚠ CAUTION:** Many repairs may only be done by a certified service technician. You should only perform troubleshooting and simple repairs as authorized in your product documentation, or as directed by the online or telephone service and support team. Damage due to servicing that is not authorized by Dell is not covered by your warranty. Read and follow the safety instructions that came with the product.

1. Enter the System Setup and ensure that the **USB key port** is enabled on the **Integrated Devices** screen.

2. Turn off the system and attached peripherals, and disconnect the system from the electrical outlet.
3. Remove the system cover.
4. Locate the USB key and reseal it.
5. Install the system cover.
6. Turn on the system and attached peripherals and check if the USB key is functioning.
7. If the problem is not resolved, repeat step 2 and step 3.
8. Insert a different USB key that you know works properly.
9. Install the system cover.

## Troubleshooting an SD card

**CAUTION:** Many repairs may only be done by a certified service technician. You should only perform troubleshooting and simple repairs as authorized in your product documentation, or as directed by the online or telephone service and support team. Damage due to servicing that is not authorized by Dell is not covered by your warranty. Read and follow the safety instructions that came with the product.

**NOTE:** Certain SD cards have a physical write-protect switch on the card. If the write-protect switch is turned on, the SD card is not writable.

1. Enter System Setup, and ensure that the **Internal SD Card Port** is enabled.
2. Turn off the system, including any attached peripherals, and disconnect the system from the electrical outlet.
3. Remove the system cover.

**NOTE:** When an SD card failure occurs, the internal dual SD module controller notifies the system. On the next restart, the system displays a message indicating the failure. If redundancy is enabled at the time of SD card failure, a critical alert will be logged and chassis health will degrade.

4. Replace the failed SD card with a new SD card.
5. Install the system cover.
6. Reconnect the system to its electrical outlet and turn on the system, including any attached peripherals.
7. Enter System Setup, and ensure that the **Internal SD Card Port** and **Internal SD Card Redundancy** modes are set to the required modes.

Verify that the correct SD slot is set as **Primary SD Card**.

8. Check if the SD card is functioning properly.
9. If the **Internal SD Card Redundancy** option is set to **Enabled** at the time of the SD card failure, the system prompts you to perform a rebuild.

**NOTE:** The rebuild is always sourced from the primary SD card to the secondary SD card.

## Troubleshooting an optical drive

**CAUTION:** Many repairs may only be done by a certified service technician. You should only perform troubleshooting and simple repairs as authorized in your product documentation, or as directed by the online or telephone service and support team. Damage due to servicing that is not authorized by Dell is not covered by your warranty. Read and follow the safety instructions that came with the product.

1. Try using a different CD or DVD.
2. Enter the System Setup and ensure that the integrated SATA controller and the drive's SATA port are enabled.
3. Run the appropriate diagnostic test.
4. Turn off the system and attached peripherals, and disconnect the system from the electrical outlet.
5. If installed, remove the front bezel.
6. Remove the system cover.
7. Ensure that the interface cable is securely connected to the optical drive and to the controller.
8. Ensure that a power cable is properly connected to the drive.
9. Install the system cover.

# Troubleshooting a hard drive

**CAUTION:** Many repairs may only be done by a certified service technician. You should only perform troubleshooting and simple repairs as authorized in your product documentation, or as directed by the online or telephone service and support team. Damage due to servicing that is not authorized by Dell is not covered by your warranty. Read and follow the safety instructions that came with the product.

**CAUTION:** This troubleshooting procedure can erase data stored on the hard drive. Before you proceed, back up all files on the hard drive.

1. Run the appropriate diagnostic test. For more information, see [Using System Diagnostics](#).  
Depending on the results of the diagnostics test, proceed as needed through the following steps.
2. If your system has a RAID controller and your hard drives are configured in a RAID array, perform the following steps:
  - a) Reboot the system and press <F10> during system startup to run the Lifecycle Controller, and then run the Hardware Configuration wizard to check the RAID configuration.  
See the Lifecycle Controller documentation or online help for information on RAID configuration.
  - b) Ensure that the hard drive(s) are configured correctly for the RAID array.
  - c) Take the hard drive offline and reseal the drive.
  - d) Exit the configuration utility and allow the system to boot to the operating system.
3. Ensure that the required device drivers for your controller card are installed and are configured correctly. See the operating system documentation for more information.
4. Reboot the system and enter the System Setup.
5. Verify that the controller is enabled and the drives are displayed in the System Setup.

# Troubleshooting a storage controller

**CAUTION:** Many repairs may only be done by a certified service technician. You should only perform troubleshooting and simple repairs as authorized in your product documentation, or as directed by the online or telephone service and support team. Damage due to servicing that is not authorized by Dell is not covered by your warranty. Read and follow the safety instructions that came with the product.

**NOTE:** When troubleshooting a SAS or PERC controller, see the documentation for your operating system and the controller.

1. Run the appropriate diagnostic test. For more information, see [Using System Diagnostics](#).
2. Turn off the system and attached peripherals, and disconnect the system from the electrical outlet.
3. Remove the system cover.
4. Verify that the installed PERC card is compliant with the expansion card installation guidelines.
5. Ensure that the PERC card is firmly seated in its connector.
6. Install the system cover.
7. Reconnect the system to the electrical outlet, and turn on the system and attached peripherals.
8. If the problem is not resolved, turn off the system and attached peripherals, and disconnect the system from the electrical outlet.
9. Remove the system cover.
10. Remove all expansion cards installed in the system.
11. Install the system cover.
12. Reconnect the system to the electrical outlet, and turn on the system and attached peripherals.
13. Run the appropriate diagnostic test.
14. For each expansion card you removed in step 10, perform the following steps:
  - a. Turn off the system and attached peripherals, and disconnect the system from the electrical outlet.
  - b. Remove the system cover.
  - c. Reinstall one of the expansion cards.
  - d. Install the system cover.
  - e. Run the appropriate diagnostic test.

# Troubleshooting expansion cards

**CAUTION:** Many repairs may only be done by a certified service technician. You should only perform troubleshooting and simple repairs as authorized in your product documentation, or as directed by the online or telephone service and support team. Damage due to servicing that is not authorized by Dell is not covered by your warranty. Read and follow the safety instructions that came with the product.

**NOTE:** When troubleshooting an expansion card, see the documentation for your operating system and the expansion card.

1. Run the appropriate diagnostic test. For more information, see [Using System Diagnostics](#).
2. Turn off the system and attached peripherals, and disconnect the system from the electrical outlet.
3. Remove the system cover.
4. Ensure that each expansion card is firmly seated in its connector.
5. Install the system cover.
6. If the problem is not resolved, turn off the system and attached peripherals, and disconnect the system from the electrical outlet.
7. Remove the system cover.
8. Remove all expansion cards installed in the system.
9. Install the system cover.
10. For each expansion card you removed in step 8, perform the following steps:
  - a) Turn off the system and attached peripherals, and disconnect the system from the electrical outlet.
  - b) Remove the system cover.
  - c) Reinstall one of the expansion cards.
  - d) Install the system cover.
  - e) Run the appropriate diagnostic test. For more information, see [Using System Diagnostics](#).

# Troubleshooting processors

**CAUTION:** Many repairs may only be done by a certified service technician. You should only perform troubleshooting and simple repairs as authorized in your product documentation, or as directed by the online or telephone service and support team. Damage due to servicing that is not authorized by Dell is not covered by your warranty. Read and follow the safety instructions that came with the product.

1. Run the appropriate diagnostics test. See [Using System Diagnostics](#) for available diagnostic tests.
2. Turn off the system and attached peripherals, and disconnect the system from the electrical outlet.
3. Remove the system cover.
4. Ensure that the processor and heat sink are properly installed.
5. Install the system cover.
6. Run the appropriate diagnostic test. For more information, see [Using System Diagnostics](#).

# Error Messages

## Errors That Halt the System Completely

The following is a list of BIOS error messages that will halt the system completely requiring you to cycle the system's power:

- Error! Memory configured incorrectly. Please enter Setup for Memory Information details
- Alert! Processor Cache Size Mismatch.
- Alert! Processor Type Mismatch.
- Alert! Processor Speed Mismatch.
- Alert! Incompatible Processor Mismatch.

## Errors That Soft Halts the System

The following is a list of BIOS error messages that will cause a soft halt of the system and then the user will be prompted to press F1 to continue or F2 to enter the system setup:

- Alert! Air temperature sensor not detected.
- Alert! Card-cage fan failure.
- Alert! CPU 0 fan failure.
- Alert! Chipset heatsink not detected.
- Alert! Operating is debug mode. Please populate memory in pairs for normal operation.
- Alert! Power supply fan failure.
- Alert! Previous fan failure.
- Alert! Previous processor thermal failure.
- Alert! Previous reboot was due to voltage regulator failure.
- Alert! Previous shutdown due to thermal event.
- Alert! Previous voltage failure.
- Alert! System battery voltage is low.
- Alert! Uncorrectable memory error previously detected at XXXXXXXXXXh
- Alert! Unable to initialize fan controller.
- Plug and Play Configuration Error

## Error That do not Halt the system

The following is a list of BIOS error messages that do not halt the system but will display a warning messages, pause for a few seconds, and then continue to boot:

- Alert! Cover was previously removed.
- Alert! Error initializing PCI Express slot n (or bridge).

## System messages

For a list of event and error messages generated by the system firmware and agents that monitor system components, see the Dell Event and Error Messages Reference Guide at [Dell.com/openmanagemanuals](https://dell.com/openmanagemanuals) > **OpenManage software**.

## Warning messages

A warning message alerts you to a possible problem and prompts you to respond before the system continues a task. For example, before you format a hard drive, a message warns you that you may lose all data on the hard drive. Warning messages usually interrupt the task and require you to respond by typing y (yes) or n (no).

 **NOTE: Warning messages are generated by either the application or the operating system. For more information, see the documentation that accompanied the operating system or application.**

## Diagnostic messages

The system diagnostic utilities may issue messages if you run diagnostic tests on your system. For more information about system diagnostics, see [Using system diagnostics](#).

## Alert messages

The systems management software generates alert messages for your system. Alert messages include information, status, warning, and failure messages for drive, temperature, fan, and power conditions. For more information, see the systems management software documentation (Dell OpenManage Systems Management Overview Guide at [dell.com/openmanagemanuals](https://dell.com/openmanagemanuals)).



# Using system diagnostics

If you experience a problem with your system, run the system diagnostics before contacting Dell for technical assistance. The purpose of running system diagnostics is to test your system hardware without requiring additional equipment or risking data loss. If you are unable to fix the problem yourself, service and support personnel can use the diagnostics results to help you solve the problem.

## Topics:

- [Dell Embedded System Diagnostics](#)

## Dell Embedded System Diagnostics

**NOTE:** The Dell Embedded System Diagnostics is also known as Enhanced Pre-boot System Assessment (ePSA) diagnostics.

The Embedded System Diagnostics provides a set of options for particular device groups or devices enabling you to:

- Run tests automatically or in an interactive mode
- Repeat tests
- Display or save test results
- Run thorough tests to introduce additional test options to provide extra information about the failed device(s)
- View status messages that inform you if tests are completed successfully
- View error messages that inform you of problems encountered during testing

## When to use the Embedded System Diagnostics

Run the Embedded System Diagnostics (ePSA) if your system does not boot.

## Running the Embedded System Diagnostics from Boot Manager

1. When the system is booting, press F11.
2. Use the up and down arrow keys to select **System Utilities > Launch Diagnostics**.  
The **ePSA Pre-boot System Assessment** window is displayed, listing all devices detected in the system. The diagnostics starts executing the tests on all the detected devices.

## Running the Embedded System Diagnostics from the Dell Lifecycle Controller

1. As the system boots, press F11.
2. Select **Hardware Diagnostics → Run Hardware Diagnostics**.  
The **ePSA Pre-boot System Assessment** window is displayed, listing all devices detected in the system. The diagnostics starts executing the tests on all the detected devices.

## System diagnostics controls

Menu	Description
<b>Configuration</b>	Displays the configuration and status of all detected devices.
<b>Results</b>	Displays the results of all tests that are executed.

**Menu****Description****System health**

Provides the current overview of the system performance.

**Event log**

Displays a time-stamped log of the results of all tests run on the system. This is displayed if at least one event description is recorded.

# Jumpers and connectors





## Topics:

- [System board jumper settings](#)
- [System board connectors](#)
- [Disabling a forgotten password](#)

## System board jumper settings

For information on resetting the password jumper to disable a password, see [Disabling a forgotten password](#).

**Table 9. System board jumper settings**

Jumper	Setting	Description
PWRD_EN	 2 4 6 (default)	The password reset feature is enabled (pins 2–4). BIOS local access is unlocked at the next AC power cycle.
	 2 4 6	The password reset feature is disabled (pins 4–6).
NVRAM_CLR	 1 3 5 (default)	The configuration settings are retained at the next system boot (pins 3–5).
	 1 3 5	The configuration settings are cleared at system boot (pins 1–3).

# System board connectors

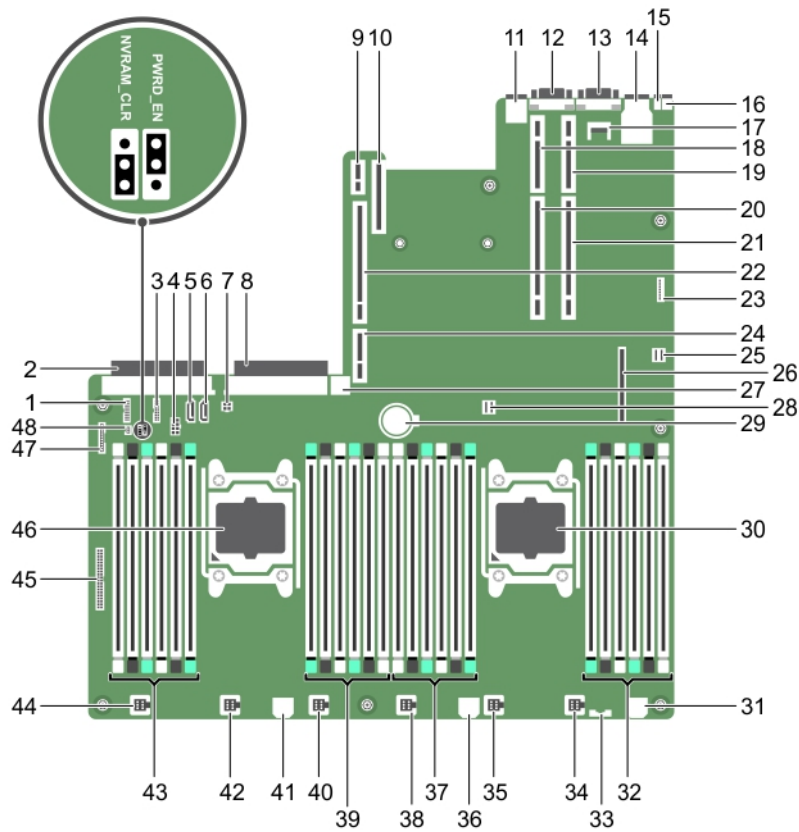

Figure 47.

Item	Connector	Description
1	J_BP_SIG1	Backplane signal connector 1
2	J_PS_2	PSU 2 connector
3	J_BP_SIG0	Backplane signal connector 0
4	J_BP0	Backplane power connector 0
5	J_SATA_CD	Optical drive SATA connector
6	J_SATA_TBU	Tape backup unit SATA connector
7	J_TBU	Tape backup unit power connector
8	J_PS_1	PSU 1 connector
9	J_IDSDM	Internal dual SD module connector
10	J_NDC	Network daughter card connector
11	J_USB	USB connector
12	J_VIDEO_REAR	Video connector
13	J_COM1	Serial connector
14	J_IDRAC_RJ45	iDRAC8 connector
15	J_CYC	System identification connector
16	CYC_ID	System identification button
17	J_TPM_MODULE	Trusted Platform Module connector

Item	Connector	Description
18	J_RISER_2AX	Riser 3 connector
19	J_RISER_1AX	Riser 1 connector
20	J_RISER_2BX	Riser 2 connector
21	J_RISER_1BX	Riser 1 connector
22	J_RISER_3AX	Riser 3 connector
23	J_QS	Quick Sync bezel connector
24	J_RISER_3BX	Riser 3 connector
25	J_SATA_B	Internal SAS connector
26	J_STORAGE	Mini PERC connector
27	J_USB_INT	Internal USB connector
28	J_SATA_A	Internal SAS connector
29	BAT	Battery connector
30	CPU 2	Processor socket 2
31	J_BP3	Backplane power connector 3
32	B10, B6, B2, B9, B5, B1	Memory module sockets
33	J_BP_SIG2	Backplane signal connector 2
34	J_FAN2U_6	Cooling fan connector
35	J_FAN2U_5	Cooling fan connector
36	J_BP2	Backplane power connector 2
37	B3, B7, B11, B4, B8, B12	Memory module sockets
38	J_FAN2U_4	Cooling fan connector
39	A10, A6, A2, A9, A5, A1	Memory module sockets
40	J_FAN2U_3	Cooling fan connector
41	J_BP1	Backplane power connector
42	J_FAN2U_2	Cooling fan connector
43	A3, A7, A11, A4, A8, A12	Memory module sockets
44	J_FAN2U_1	Cooling fan connector
45	J_CTRL_PNL	Control panel signal connector
46	CPU 1	Processor 1
47	J_FP_USB	Front-panel USB connector
48	Tera2 host card	Power connector

## Disabling a forgotten password

The software security features of the system include a system password and a setup password. The password jumper enables these password features or disables them and clears any password(s) currently in use.

**⚠ CAUTION: Many repairs may only be done by a certified service technician. You should only perform troubleshooting and simple repairs as authorized in your product documentation, or as directed by the online or telephone service and support team. Damage due to servicing that is not authorized by Dell is not covered by your warranty. Read and follow the safety instructions that came with the product.**

1. Turn off the system, including any attached peripherals, and disconnect the system from the electrical outlet.
2. Remove the system cover.

3. Move the jumper on the system board jumper from pins 4 and 6 to pins 2 and 4.
4. Install the system cover.

The existing passwords are not disabled (erased) until the system boots with the jumper on pins 2 and 4. However, before you assign a new system and/or setup password, you must move the jumper back to pins 4 and 6.

**i** **NOTE: If you assign a new system and/or setup password with the jumper on pins 2 and 4, the system disables the new password(s) the next time it boots.**

5. Reconnect the system to its electrical outlet and turn the system on, including any attached peripherals.
6. Turn off the system, including any attached peripherals, and disconnect the system from the electrical outlet.
7. Remove the system cover.
8. Move the jumper on the system board jumper from pins 2 and 4 to pins 4 and 6.
9. Install the system cover.
10. Reconnect the system to its electrical outlet and turn the system on, including any attached peripherals.
11. Assign a new system and/or setup password.

# Specifications

**NOTE:** Offerings may vary by region. The following specifications are only those required by law to ship with your computer. For more information about the configuration of your computer, go to [Help and Support](#) in your Windows operating system and select the option to view information about your computer.

**Table 10. Processor**

Feature	Specification
Type	One or two Intel Xeon processor E5-2600 v3 product family
Cache	
Instruction Cache	32 KB
Data Cache	32 KB
	256 KB Mid-Level Cache per core
	up to 20 MB (4C: 10 MB, 6C: 15 MB/12 MB, 8C: 20 MB) Last-Level Cache shared among all cores

**Table 11. System Information**

Feature	Specification
Chipset	Intel C612 chipset
BIOS chip (NVRAM)	8 MB + 4 MB serial flash EEPROM

**Table 12. Memory**

Memory	Specification
Type	1333 MT/s, 1600 MT/s, 1866 MT/s or 2133 MT/s DDR4 registered, load-reduced Error Correcting Code (ECC) DIMMs Support for advanced ECC or memory optimized operation
Speed	1866 Mhz, 2133 Mhz, or 1600 MHz
Memory module sockets	Twenty-four 288-pin
Capacity	2 GB, 4 GB, 8 GB, and 16 GB
LRDIMMs	32 GB quad-ranked
RDIMMs	4 GB single-ranked, 8 GB or 16 GB dual-ranked
Minimum memory	4 GB with a single processor 8 GB with a dual processor (minimum one DIMM module per processor)
Maximum memory	
LRDIMMs	Up to 768 GB with a dual processor Up to 256 GB with a single processor

**Table 13. Video**

Video	Specification
Video type	Matrox G200eR2
Video memory	16 MB

**Table 14. Network**

Network	Specification
Integrated	Intel 82579 and Intel 82574 Ethernet controllers

**Table 15. Expansion Bus**

Expansion Bus	Specification
Bus type:	PCI Express Generation 3
Bus speed:	PCI: 133 MB/s PCI Express: <ul style="list-style-type: none"> <li>• PCIe 3.0 x16 slots bidirectional speed - 16 GB/s</li> <li>• PCIe 3.0 x8-slots bidirectional speed - 8 GB/s</li> <li>• PCIe 3.0 x4 slots bidirectional speed - 4 GB/s</li> <li>• PCIe 2.0 x4-slots bidirectional speed - 2 GB/s</li> </ul>
	PCI 2.3 (32-bit, 33MHz) : 133MB/s
	SAS: 3 Gbps and 6 Gbps
	SATA: 1.5 Gbps, 3 Gbps, and 6 Gbps
	USB 3.0: 480 Mbps high speed, 12 Mbps full speed, 1.2 Mbps low speed

**Table 16. Card Slots**

Card Slots	Specification
Riser 1	
Slot 1	One half-height, low-profile x8 link
Slot 2	One half-height, low-profile x8 link
Slot 3	One half-height, low-profile x8 link
Riser 2	
Slot 4	One full-height, full-length x16 link <b>NOTE: To use slots 1 through 4, both the processors must be installed.</b>
Slot 5	One full-height, full-length x8 link
Riser 3 (default)	
Slot 6	One full-height, full-length x8 link
Slot 7	One full-height, full-length x8 link
Riser 3 (alternate for GPU)	
Slot 6	One full-height, full-length x16 link

**Table 17. Drives**

Drives	Specification
Hard drives	
Eight-hard-drive systems	Up to eight 2.5 inch, internal, HDD/SSD, or Nearline SAS hard drives in hard-drive slots 0 through 7.
Internally accessible	none
Optical drive	One optional SATA DVD-ROM drive or DVD+/-RW drive. <b>NOTE: DVD devices are data only.</b>



**Table 18. External Connectors**

External connectors	Specification
NIC	Four 1 Gbps or two 1 Gbps plus two 10 Gbps
Network	two RJ-45
Serial	9-pin, DTE, 16550-compatible
USB	Two 4-pin, USB 3.0 compliant Two 4 pin USB 2.0 compliant
Video	15-pin VGA
System ID	Cable Management Arm (CMA) remote LED connector
External vFlash card	One flash memory card slot with iDRAC8 Enterprise card

**Table 19. Internal Connectors**

Internal connectors	Specification
SATA	two 36-pin Mini-SAS connectors; one seven-pin SATA connector
Risers	two 280-pin connectors
Internal USB	One 4-pin, USB 3.0-compliant
System power	one 24-pin connector
Power distribution board communication	one six-pin connector
Front panel control	one 28-pin connector
Systems fans	six four-pin connectors
Host card remote power control	one two-pin connector
CPU/Memory power	four four-pin connectors
Memory	twenty four 240-pin connectors (DDR4)
Risers:	
Riser 1	
PCI Express	three 164-pin connectors (x8)
Center Riser Option 3: Default	
PCI Express	two 164 pin connectors (x8)
Left Riser	
PCI Express	one 164 pin or two 164 pin
Front IO:	
Front USB	one 14-pin connector
Front panel control	one 28-pin connector
HDD Back Panel :	
SATA	two 36-pin Mini-SAS connectors; eight 29-pin HDD connectors
Power	one 14-pin connector

**Table 20. Controls and Lights**

Controls and Lights	Specification
Power button light:	off — system is off or unplugged. solid blue light — computer is operating normally. blinking blue light — computer is in stand by.

Controls and Lights	Specification
	solid amber light — the computer does not start, indicating a problem with the system board or power supply.
	blinking amber light — indicates a problem has occurred with the system board.
System ID button and light	blue light — flashes (front and back of chassis) when the button is pressed. Press the button again to turn it off.
Drive activity light	blue light — blinking blue light indicates that the computer is reading data from, or writing data to the hard drive.
Network link integrity lights (front):	blue light — A good connection exists between the network and the computer. off (no light) — The computer is not detecting a physical connection to the network.
Network link integrity and activity indicator lights (rear):	Link and activity indicators are off — The NIC is not connected to the network.  Link indicator is green — The NIC is connected to a valid network at its maximum port speed (1 Gbps or 10 Gbps).  Link indicator is amber — The NIC is connected to a valid network at less than its maximum port speed.  Activity indicator is blinking green — Network data is being sent or received.

**Table 21. Power**

Power	Specification
Coin-cell battery	3 V CR2032 lithium coin cell
Voltage	100 V to 240 V, 12.00 A to 6.00 A, 50 Hz to 60 Hz
Wattage	1100 W : 200 VAC to 240 VAC
Maximum heat dissipation	4774 BTU/hr

**NOTE:** Heat dissipation is calculated by using the power supply wattage rating.

**NOTE:** See the safety information that shipped with your computer for important voltage-setting information.

**Table 22. Physical**

Physical	Specification
Height	8.73 cm (3.44 inch)
Width	48.2 cm (18.98 inch)
Depth	75.58 cm (29.75 inch)
Weight (Minimum)	• 31.4 kg (69.23 lb) (2.5 inch hard drive systems)
Empty Weight	• 20.8 kg (45.86 lb) (2.5 inch hard drive systems)
without front bezel	19.06 kg (41.92 lb)

**Table 23. Environmental**

Environmental	Specification
Temperature:	
Operating	10 °C to 35 °C (50 °F to 95 °F)
Storage	-40 °C to 65 °C (-40 °F to 149 °F)
Maximum	20°C/h (36°F/h)
Restriction	K6000/K20 cards + 160 w processor is limited to 30 c operating temperature maximum.

Environmental	Specification
Relative humidity (maximum):	
Operating	5% to 95% RH with 33°C (91°F) maximum dew point. Atmosphere must be non-condensing at all times.
Storage	10% to 80% Relative Humidity with 29°C (84.2°F) maximum dew point.
Maximum vibration:	
Operating	0.26 Grms at 5 Hz to 350 Hz (all operation orientations).
Storage	1.88 Grms at 10 Hz to 500 Hz for 15 min (all six sides tested).
Maximum shock:	
Operating	Six consecutively executed shock pulses in the positive and negative x, y, and z axes of 40 G for up to 2.3 ms.
Storage	Six consecutively executed shock pulses in the positive and negative x, y, and z axes (one pulse on each side of the system) of 71 G for up to 2 ms.
Airborne contaminant level	G1 or lower as defined by ISA-S71.04-1985
Maximum Altitude	
Operating	3048 m (10,000 ft).
Storage	12,000 m (39,370 ft).
Operating Temperature De-rating	
Up to 35 °C (95 °F)	Maximum temperature is reduced by 1°C/300 m (1°F/547 ft) above 950 m (3,117 ft).
35 °C to 40 °C (95 °F to 104 °F)	Maximum temperature is reduced by 1°C/175 m (1°F/319 ft) above 950 m (3,117 ft).
40 °C to 45 °C (104 °F to 113 °F)	Maximum temperature is reduced by 1°C/125 m (1°F/228 ft) above 950 m (3,117 ft).

**NOTE:** 本产品满足 GB28380-2012 的要求，其能效等级及对应的能效参数值的评估是基于 Window 操作系统开展的，具体信息请参看产品外包装的能效标签。

# System Setup

## Topics:

- [Boot Menu](#)
- [Timing Key Sequences](#)
- [Dell Diagnostics](#)
- [About system setup](#)

## Boot Menu

As with previous workstation platforms, this computer includes a one-time boot menu. This feature gives users a quick and convenient mechanism to bypass the System Setup-defined boot device order and boot directly to a specific device (for example: floppy, CD-ROM, or hard drive). The boot menu enhancements introduced on previous platforms are as follows:

- **Easier access** — Although the <Ctrl><Alt><F8> keystroke still exists and can be used to call up the menu, simply press <F12> during system boot to access the menu.
- **User prompting** — Not only is the menu easy to access, but the user is prompted to use the keystroke on the BIOS splash screen. The keystroke is no longer "hidden" from the user.
- **Diagnostics options** — The boot menu includes two diagnostic options, IDE Drive Diagnostics (90/90 Hard Drive Diagnostics) and Boot to the Utility Partition. The benefit here is that the user does not have to remember the <Ctrl><Alt><D> and <Ctrl><Alt><D> and <Ctrl><Alt><F10> keystrokes.

**NOTE:** Since the one-time boot menu only affects the current boot, it has the added benefit of not requiring the technician to restore the customer's boot order after completing troubleshooting.

The computer has several keystroke options available during the POST process at the Dell Logo screen. These keystrokes make several options available.

Keystroke	Function	Description
<F2>	Enter System Setup	Use System Setup to make changes to the user-definable settings.
<F12>	Enter Boot Menu	One-time boot and diagnostics utility menu.

## Timing Key Sequences

The keyboard is not the first device initialized by Setup. As a result, if you press a keystroke too early, you lock out the keyboard. When this happens, a keyboard error message appears on the monitor, and you cannot restart the system with the <Ctrl><Alt><Del> keys.

To avoid this scenario, wait until the keyboard is initialized before pressing the keystroke. There are two ways to know that this has happened:

- The keyboard lights flash.

The second method is good if the monitor is already warmed up. If it is not, the system often passes the window of opportunity before the video signal is visible. If this is the case, rely on the first method—the keyboard lights—to know the keyboard is initialized.

## Dell Diagnostics

Factory-installed platforms include 32-bit system diagnostics on the installed utility partition. Access these diagnostics using the <F12> keystroke during system boot and select Diagnostics.

After pressing the keystroke, the appropriate modules load and the PSA diagnostics run. If this passes, the standard Dell Diagnostics main menu appears. When exiting the diagnostics, the system reboots and returns to the installed operating system. Restarting the computer with the <Ctrl><Alt><Del> keystroke also returns the system to the normal boot sequence as well.

Drives sent for service replacement do not have the utility partition and therefore do not have this capability. If pressed, the keystroke is ignored on these drives.

**NOTE:** The utility partition is not protected from debug routines or the FDISK utility.

## About system setup

By using the **System Setup** screen, you can configure the BIOS settings, iDRAC settings, and device settings of your system. These settings have already been preconfigured per solution requirements. Contact Dell before you change these settings.

**NOTE:** Help text for the selected field is displayed in the graphical browser by default. To view the help text in the text browser, press F1.

You can access system setup in two ways:

- Standard graphical browser—The browser is enabled by default.
- Text Browser—The browser is enabled by using Console Redirection.

## Entering System Setup

1. Turn on, or restart your system.
2. Press F2 immediately after you see the following message:

```
F2 = System Setup
```

If your operating system begins to load before you press F2, wait for the system to finish booting, and then restart your system and try again.

## System Setup Main Menu

Option	Description
<b>System BIOS</b>	Enables you to configure BIOS settings.
<b>iDRAC Settings</b>	Enables you to configure iDRAC settings.  The iDRAC Settings utility is an interface to set up and configure the iDRAC parameters using UEFI. You can enable or disable various iDRAC parameters by using the iDRAC Settings utility. For more information about this utility, see the Integrated Dell Remote Access Controller User's Guide at <a href="http://dell.com/esmanuals">dell.com/esmanuals</a> .
<b>Device Settings</b>	Enables you to configure device settings.
<b>Service Tag Settings</b>	Enables service tag of the system

## System BIOS screen

You can use the **System BIOS** screen to view BIOS settings as well as edit specific functions such as boot order, system password, setup password, setting RAID mode, and enabling or disabling USB ports.

In the **System Setup Main Menu**, click **System BIOS**.

The **System BIOS** screen details are explained below.

Menu Item	Description
<b>System Information</b>	Displays information about the system such as the system model name, BIOS version, Service Tag, and so on.
<b>Memory Settings</b>	Displays information and options related to installed memory.
<b>Processor Settings</b>	Displays information and options related to the processor such as speed, cache size, and so on.

Menu Item	Description
<b>SATA Settings</b>	Displays options to enable or disable the integrated SATA controller and ports.
<b>Boot Settings</b>	Displays options to specify the boot mode (BIOS or UEFI). Enables you to modify UEFI and BIOS boot settings.
<b>Integrated Devices</b>	Displays options to enable or disable integrated device controllers and ports, and to specify related features and options.
<b>Serial Communication</b>	Displays options to enable or disable the serial ports and specify related features and options.
<b>System Profile Settings</b>	Displays options to change the processor power management settings, memory frequency, and so on.
<b>System Security</b>	Displays options to configure the system security settings like, system password, setup password, TPM security, and so on. It also enables or disables support for the power and NMI buttons on the system.
<b>Miscellaneous Settings</b>	Displays options to change the system date, time, and so on.
<b>Debug Menu Settings</b>	This field controls serial debug output level for certain drivers.

## System Information screen details

You can use the **System Information** screen allows to view system properties such as Service Tag, system model, and BIOS version.

You can view the **System Information** screen by clicking **System Setup Main Menu > System BIOS > System Information**.

The **System Information** screen details are explained as follows:

Menu Item	Description
<b>System Model Name</b>	Displays the system model name.
<b>System BIOS Version</b>	Displays the BIOS version installed on the system.
<b>System Management Engine Version</b>	Displays the current revision of the Management Engine firmware.
<b>System Service Tag</b>	Displays the system Service Tag.
<b>System Manufacturer</b>	Displays the name of the system manufacturer.
<b>System Manufacturer Contact Information</b>	Displays the contact information of the system manufacturer.
<b>System CPLD Version</b>	Displays the current revision of the system CPLD firmware.
<b>UEFI Compliance Version</b>	Displays the system firmware UEFI compliance level.

## Memory Settings screen details

You can use the **Memory Settings** screen to view all the memory settings as well as to enable or disable specific memory functions such as system memory testing and node interleaving.

You can view the **Memory Setting** screen by clicking **System Setup Main Menu > System BIOS > Memory Settings**.

The **Memory Settings** screen details are explained as follows:

Menu Item	Description
<b>System Memory Size</b>	Displays the amount of memory installed in the system.
<b>System Memory Type</b>	Displays the type of memory installed in the system.
<b>System Memory Speed</b>	Displays the system memory speed.
<b>System Memory Voltage</b>	Displays the system memory voltage.
<b>Video Memory</b>	Displays the amount of video memory.
<b>System Memory Testing</b>	Specifies whether system memory tests are run during system boot. Options are <b>Enabled</b> and <b>Disabled</b> . By default, the <b>System Memory Testing</b> option is set to <b>Disabled</b> .
<b>Memory Operating Mode</b>	Specifies the memory operating mode. By default <b>Optimizer Mode</b> . <i>i</i> <b>NOTE: The Memory Operating Mode can have different defaults and available options based on the memory configuration of your system.</b> <i>i</i> <b>NOTE: The Dell Fault Resilient Mode establishes an area of memory that is fault resilient. This mode can be used by an operating system that supports the feature to load critical applications or enables the operating system kernel to maximize system availability.</b>
<b>Node Interleaving</b>	Specifies if Non-Uniform Memory architecture (NUMA) is supported. If this field is <b>Enabled</b> , memory interleaving is supported if a symmetric memory configuration is installed. If <b>Disabled</b> , the system supports NUMA (asymmetric) memory configurations. By default, <b>Node Interleaving</b> option is set to <b>Disabled</b> .
<b>Snoop Mode</b>	Specifies the Snoop Mode options. Snoop Mode options available are <b>Home Snoop</b> , <b>Early Snoop</b> , <b>Cluster on Die</b> . By default, the Snoop Mode option is set to <b>Early Snoop</b> . The field is only available when Node Interleaving is <b>Disabled</b> .



## Processor Settings screen details

You can use the **Processor Settings** screen to view the processor settings and perform specific functions such as enabling virtualization technology, hardware prefetcher, and logical processor idling.

You can view the **Processor Settings** screen by clicking **System Setup Main Menu > System BIOS > Processor Settings**.

The **Processor Settings** screen details are explained as follows:

Menu Item	Description
<b>Logical Processor</b>	Enables or disables the logical processors and displays the number of logical processors. If the <b>Logical Processor</b> option is set to <b>Enabled</b> , the BIOS displays all the logical processors. If this option is set to <b>Disabled</b> , the BIOS only displays one logical processor per core. By default, the <b>Logical Processor</b> option is set to <b>Enabled</b> .
<b>Maximum data rate</b>	QPI Speed maximum data rate 9.6 Gt/s, 8.0 GT/s, 6.4 GT/s
<b>Alternate RTID (Requestor Transaction ID) Setting</b>	Enables you to allocate more RTIDs to the remote socket, thereby increasing cache performance between the sockets or easing work in normal mode for NUMA. By default, the <b>Alternate RTID (Requestor Transaction ID) Setting</b> is set to <b>Disabled</b> .
<b>Virtualization Technology</b>	Enables or disables the additional hardware capabilities provided for virtualization. By default, the <b>Virtualization Technology</b> option is set to <b>Enabled</b> .
<b>Address Translation Services (ATS)</b>	Allows you to define the Address Translation Cache (ATC) for devices to cache the DMA transactions. This field provides an interfaces to a chipset's Address Translation and Protection Table to translate DMA addresses to host addresses. By default, the option is set to <b>Enabled</b> .
<b>Adjacent Cache Line Prefetch</b>	Optimizes the system for applications that require high utilization of sequential memory access. By default, the <b>Adjacent Cache Line Prefetch</b> option is set to <b>Enabled</b> . You can disable this option for applications that require high utilization of random memory access.

Menu Item	Description
<b>Hardware Prefetcher</b>	Enables or disables the hardware prefetcher. By default, the <b>Hardware Prefetcher</b> option is set to <b>Enabled</b> .
<b>DCU Streamer Prefetcher</b>	Allows you to enable or disable the Data Cache Unit (DCU) streamer prefetcher. By default, the <b>DCU Streamer Prefetcher</b> option is set to <b>Enabled</b> .
<b>DCU IP Prefetcher</b>	Enables or disables the Data Cache Unit (DCU) IP prefetcher. By default, the <b>DCU IP Prefetcher</b> option is set to <b>Enabled</b> .
<b>Execute Disable</b>	Enables or disables the execute disable memory protection technology. By default, the <b>Execute Disable</b> option is set to <b>Enabled</b> .
<b>Logical Processor Idling</b>	Enables or disables the operating system capability to put logical processors in the idling state in order to reduce power consumption. By default, the option is set to <b>Disabled</b> .
<b>Configurable TDP</b>	Allows reconfiguration of Thermal Design Power (TDP) to lower levels. TDP refers to the maximum amount of power the cooling system is required to dissipate.
<b>X2Apic Mode</b>	Enables or disables the X2Apic mode.
<b>Dell Controlled Turbo</b>	 <b>NOTE: Depending on the number of installed CPUs, there may be up to four processor listings.</b> Controls the turbo engagement. Enable this option only when <b>System Profile</b> is set to <b>Performance</b> .
<b>Number of Cores per Processor</b>	Controls the number of enabled cores in each processor. By default, the <b>Number of Cores per Processor</b> option is set to <b>All</b> .
<b>Processor 64-bit Support</b>	Specifies if the processor(s) support 64-bit extensions.
<b>Processor Core Speed</b>	Displays the maximum core frequency of the processor.
<b>Processor 1</b>	 <b>NOTE: Depending on the number of installed CPUs, there may be up to four processor listings. The following settings are displayed for each processor installed in the system.</b>
<b>Family-Model-Stepping</b>	Displays the family, model and stepping of the processor as defined by Intel.
<b>Brand</b>	Displays the brand name reported by the processor.
<b>Level 2 Cache</b>	Displays the total L2 cache.
<b>Level 3 Cache</b>	Displays the total L3 cache.
<b>Number of Cores</b>	Displays the number of cores per processor.
<b>Processor 2</b>	 <b>NOTE: Depending on the number of installed CPUs, there may be up to four processor listings. The following settings are displayed for each processor installed in the system.</b>
<b>Family-Model-Stepping</b>	Displays the family, model and stepping of the processor as defined by Intel.
<b>Brand</b>	Displays the brand name reported by the processor.
<b>Level 2 Cache</b>	Displays the total L2 cache.
<b>Level 3 Cache</b>	Displays the total L3 cache.
<b>Number of Cores</b>	Displays the number of cores per processor.

## SATA Settings screen details

You can use the **SATA Settings** screen to view the SATA settings of SATA devices and enable RAID on your system.

You can view the **SATA Settings** screen by clicking **System Setup Main Menu > System BIOS > SATA Settings**.

The **SATA Settings** screen details are explained below.



<b>Menu Item</b>	<b>Description</b>
<b>Embedded SATA</b>	Enables the embedded SATA to be set to <b>Off</b> , <b>ATA</b> , <b>AHCI</b> , or <b>RAID</b> modes. By default, the <b>Embedded SATA</b> option is set to <b>AHCI</b> .
<b>Security Freeze Lock</b>	Sends Security Freeze Lock command to the Embedded SATA drives during POST. This option is only applicable to ATA and AHCI mode.
<b>Write Cache</b>	Enables or disables the command for Embedded SATA drives during POST.
<b>Port A</b>	Sets the drive type of the selected device. For <b>Embedded SATA settings</b> in <b>ATA</b> mode, set this field to <b>Auto</b> to enable BIOS support. Set it to <b>OFF</b> to turn off BIOS support. For <b>AHCI</b> mode or <b>RAID</b> mode, BIOS always enables support.
<b>Model</b>	Displays the drive model of the selected device.
<b>Drive Type</b>	Displays the type of drive attached to the SATA port.
<b>Capacity</b>	Displays the total capacity of the hard drive. The field is undefined for removable media devices such as optical drives.
<b>Port B</b>	Sets the drive type of the selected device. For <b>Embedded SATA settings</b> in <b>ATA</b> mode, set this field to <b>Auto</b> to enable BIOS support. Set it to <b>OFF</b> to turn off BIOS support. For <b>AHCI</b> mode or <b>RAID</b> mode, BIOS always enables support.
<b>Model</b>	Displays the drive model of the selected device.
<b>Drive Type</b>	Displays the type of drive attached to the SATA port.
<b>Capacity</b>	Displays the total capacity of the hard drive. The field is undefined for removable media devices such as optical drives.
<b>Port C</b>	Sets the drive type of the selected device. For <b>Embedded SATA settings</b> in <b>ATA</b> mode, set this field to <b>Auto</b> to enable BIOS support. Set it to <b>OFF</b> to turn off BIOS support. For <b>AHCI</b> mode or <b>RAID</b> mode, BIOS always enables support.
<b>Model</b>	Displays the drive model of the selected device.
<b>Drive Type</b>	Displays the type of drive attached to the SATA port.
<b>Capacity</b>	Displays the total capacity of the hard drive. The field is undefined for removable media devices such as optical drives.
<b>Port D</b>	Sets the drive type of the selected device. For <b>Embedded SATA settings</b> in <b>ATA</b> mode, set this field to <b>Auto</b> to enable BIOS support. Set it to <b>OFF</b> to turn off BIOS support. For <b>AHCI</b> mode or <b>RAID</b> mode, BIOS always enables support.
<b>Model</b>	Displays the drive model of the selected device.
<b>Drive Type</b>	Displays the type of drive attached to the SATA port.
<b>Capacity</b>	Displays the total capacity of the hard drive. The field is undefined for removable media devices such as optical drives.
<b>Port E</b>	Sets the drive type of the selected device. For <b>Embedded SATA settings</b> in <b>ATA</b> mode, set this field to <b>Auto</b> to enable BIOS support. Set it to <b>OFF</b> to turn off BIOS support. For <b>AHCI</b> mode or <b>RAID</b> mode, BIOS always enables support.
<b>Model</b>	Displays the drive model of the selected device.
<b>Drive Type</b>	Displays the type of drive attached to the SATA port.
<b>Capacity</b>	Displays the total capacity of the hard drive. The field is undefined for removable media devices such as optical drives.
<b>Port F</b>	Sets the drive type of the selected device. For <b>Embedded SATA settings</b> in <b>ATA</b> mode, set this field to <b>Auto</b> to enable BIOS support. Set it to <b>OFF</b> to turn off BIOS support. For <b>AHCI</b> mode or <b>RAID</b> mode, BIOS always enables support.
<b>Model</b>	Displays the drive model of the selected device.



Menu Item	Description
<b>Drive Type</b>	Displays the type of drive attached to the SATA port.
<b>Capacity</b>	Displays the total capacity of the hard drive. The field is undefined for removable media devices such as optical drives.
<b>Port G</b>	<p>Sets the drive type of the selected device. For <b>Embedded SATA settings</b> in <b>ATA</b> mode, set this field to <b>Auto</b> to enable BIOS support. Set it to <b>OFF</b> to turn off BIOS support.</p> <p>For <b>AHCI</b> mode or <b>RAID</b> mode, BIOS always enables support.</p>
<b>Model</b>	Displays the drive model of the selected device.
<b>Drive Type</b>	Displays the type of drive attached to the SATA port.
<b>Capacity</b>	Displays the total capacity of the hard drive. The field is undefined for removable media devices such as optical drives.
<b>Port H</b>	<p>Sets the drive type of the selected device. For <b>Embedded SATA settings</b> in <b>ATA</b> mode, set this field to <b>Auto</b> to enable BIOS support. Set it to <b>OFF</b> to turn off BIOS support.</p> <p>For <b>AHCI</b> mode or <b>RAID</b> mode, BIOS always enables support.</p>
<b>Model</b>	Displays the drive model of the selected device.
<b>Drive Type</b>	Displays the type of drive attached to the SATA port.
<b>Capacity</b>	Displays the total capacity of the hard drive. The field is undefined for removable media devices such as optical drives.
<b>Port I</b>	<p>Sets the drive type of the selected device. For <b>Embedded SATA settings</b> in <b>ATA</b> mode, set this field to <b>Auto</b> to enable BIOS support. Set it to <b>OFF</b> to turn off BIOS support.</p> <p>For <b>AHCI</b> mode or <b>RAID</b> mode, BIOS always enables support.</p>
<b>Model</b>	Displays the drive model of the selected device.
<b>Drive Type</b>	Displays the type of drive attached to the SATA port.
<b>Capacity</b>	Displays the total capacity of the hard drive. The field is undefined for removable media devices such as optical drives.
<b>Port J</b>	<p>Sets the drive type of the selected device. For <b>Embedded SATA settings</b> in <b>ATA</b> mode, set this field to <b>Auto</b> to enable BIOS support. Set it to <b>OFF</b> to turn off BIOS support.</p> <p>For <b>AHCI</b> mode or <b>RAID</b> mode, BIOS always enables support.</p>
<b>Model</b>	Displays the drive model of the selected device.
<b>Drive Type</b>	Displays the type of drive attached to the SATA port.
<b>Capacity</b>	Displays the total capacity of the hard drive. The field is undefined for removable media devices such as optical drives.

## Boot Settings screen details

You can use the **Boot Settings** screen to set the Boot mode to either **BIOS** or **UEFI**. It also allows you to specify the boot order.

You can view the **Boot Settings** screen by clicking **System Setup Main Menu > System BIOS > Boot Settings**.

The **Boot Settings** screen details are explained as follows:

Menu Item	Description
<b>Boot Mode</b>	<p>Enables you to set the boot mode of the system.</p> <p> <b>CAUTION: Switching the boot mode may prevent the system from booting if the operating system is not installed in the same boot mode.</b></p> <p> <b>NOTE: Setting this field to UEFI disables BIOS Boot Settings menu. Setting this field to BIOS disables the UEFI Boot Settings menu.</b></p>

Menu Item	Description
	If the operating system supports UEFI, you can set this option to <b>UEFI</b> . Setting this field to <b>BIOS</b> allows compatibility with non-UEFI operating systems. By default, the <b>Boot Mode</b> option is set to <b>BIOS</b> .
<b>Boot Sequence Retry</b>	Enables or disables the boot sequence retry feature. If this field is enabled and the system fails to boot, the system reattempts the boot sequence after 30 seconds. By default, the <b>Boot Sequence Retry</b> option is set to <b>Enabled</b> .
<b>Hard Disk Failover</b>	Specifies which devices in the <b>Hard-Disk Drive Sequence</b> are attempted in the boot sequence. When the option is <b>Disabled</b> , only the first hard disk device in the list is attempted to boot. When set to <b>Enabled</b> , all hard disk devices are attempted in order, as listed in the <b>Hard-Disk Drive Sequence</b> . This option is not enabled for UEFI Boot Mode.
<b>Boot Options Settings</b>	Configures the boot sequence and the boot devices. Integrated NIC 1 Port 1 Partition 1
<b>Boot Sequence</b>	Integrated NIC 1 Port 1 Partition 1 IBA XE Slot 0100 v2308 Embedded SATA Port Optical Drive I PLDS DVD+/-RW DS-8ABSH Hard Drive C
<b>Hard-Disk Drive Sequence</b>	This field specifies the order in which hard-disk drives will be configured in the system. The first hard drive in the system will be the bootable C:....(Press F1 for more information) Embedded SATA Port Disk A: ST500UM001-1EK162

## Integrated Devices screen details

You can use the **Integrated Devices** screen to view and configure the settings of all integrated devices including the video controller, integrated RAID controller, and the USB ports.

You can view the **Integrated Devices** screen by clicking **System Setup Main Menu > System BIOS > Integrated Devices**.

The **Integrated Devices** screen details are explained below.

Menu Item	Description
<b>USB 3.0 Setting</b>	Enables or disables the USB 3.0 support. Enable this option only if your operating system supports USB 3.0. If you disable this option, devices operate at USB 2.0 speed. USB 3.0 is set to <b>Auto</b> by default
<b>User Accessible USB Ports</b>	Enables or disables the USB ports. Selecting <b>Only Back Ports On</b> disables the front USB ports, selecting <b>All Ports Off</b> disables all USB ports. The USB keyboard and mouse operates during boot process in certain operating systems. After the boot process is complete, the USB keyboard and mouse do not work if the ports are disabled. <b>NOTE: Selecting Only Back Ports On and All Ports Off will disable the USB management port and also restrict access to iDRAC features.</b>
<b>Internal USB Port</b>	Enables or disables the internal USB port. By default, the option is set to <b>Enabled</b> .
<b>Integrated Network Card 1</b>	Enables or disables the integrated network card.
<b>I/OAT DMA Engine</b>	Enables or disables the I/OAT option. Enable only if the hardware and software support the feature.
<b>Embedded Video Controller</b>	Enables or disables the <b>Current state of Embedded Video Controller</b> . By default the option <b>Disabled</b> . <b>Current State of Embedded Video Controller</b> is a read only field, indicating the current state for the Embedded Video Controller. If the Embedded Video Controller is the only display capability in the system (that is, no add-in graphics card is installed), then the Embedded Video Controller is automatically used as the primary display even if the Embedded Video Controller setting is <b>Disabled</b> . <b>NOTE: 1. If the embedded video controller is DISABLED in BIOS and if you launch the Virtual Console from the iDRAC, the Virtual Console Viewer is blank.</b> <b>NOTE: 2. All monitors must be plugged into the GPU at power on, and must remain plugged into the GPU until the system is booted into the operating system with the driver loaded. Once the</b>

Menu Item	Description
	<p><b>system is booted into the operating system the monitor can be unplugged, and then hot plugged. The monitor will not be hot pluggable unless this process is followed.</b></p> <ul style="list-style-type: none"> <li>• <b>DP cable can be hot plugged</b></li> <li>• <b>mDP cable can be hot plugged</b></li> <li>• <b>DVI cable can be hot plugged</b></li> <li>• <b>DP to VGA dongle cable cannot be hot plugged</b></li> </ul>
<b>Current State of Embedded Video Controller</b>	Displays the current state of the <b>Embedded Video Controller</b> . <b>Current State of Embedded Video Controller</b> is a read only field, indicating the current state for the Embedded Video Controller
<b>SR-IOV Global Enable</b>	Enables or disables the BIOS configuration of Single Root I/O Virtualization (SR-IOV) devices. By default, the <b>SR-IOV Global Enable</b> option is set to <b>Disabled</b> .
<b>OS Watchdog Timer</b>	If your system stops responding, this watchdog timer aids in the recovery of your operating system. When this field is set to <b>Enabled</b> , the operating system is allowed to initialize the timer. When the option is set to <b>Disabled</b> (the default), the timer will have no effect on the system.
<b>Memory Mapped I/O above 4GB</b>	Enables or disables the support for PCIe devices that require large amounts of memory. By default, the option is set to <b>Enabled</b> .
<b>Slot Disablement</b>	<p>Enables or disables the available PCIe slots on your system. The <b>Slot Disablement</b> feature controls the configuration of PCIe cards installed in the specified slot. Slot disablement must be used only when the installed peripheral card is preventing booting into the operating system or causing delays in system startup. If the slot is disabled, both the Option ROM and UEFI driver are disabled.</p> <p>This field controls the configuration of the card installed in the slot. You can set one of the following options for each of the .....(Press F1 for more information)</p> <ol style="list-style-type: none"> <li>1. Slot 1 Boot Driver <ul style="list-style-type: none"> <li>• <b>Enabled (default)</b></li> <li>• Disabled</li> </ul> </li> <li>2. Slot 2 Boot Driver <ul style="list-style-type: none"> <li>• <b>Enabled (default)</b></li> <li>• Disabled</li> </ul> </li> <li>3. Slot 3 Boot Driver <ul style="list-style-type: none"> <li>• <b>Enabled (default)</b></li> <li>• Disabled</li> </ul> </li> <li>4. Slot 4 Boot Driver <ul style="list-style-type: none"> <li>• <b>Enabled (default)</b></li> <li>• Disabled</li> </ul> </li> <li>5. Slot 5 Boot Driver <ul style="list-style-type: none"> <li>• <b>Enabled (default)</b></li> <li>• Disabled</li> </ul> </li> <li>6. Slot 6 Boot Driver <ul style="list-style-type: none"> <li>• <b>Enabled (default)</b></li> <li>• Disabled</li> </ul> </li> <li>7. Slot 7 Boot Driver <ul style="list-style-type: none"> <li>• <b>Enabled (default)</b></li> <li>• Disabled</li> </ul> </li> </ol>

# Serial Communication screen details

You can use the **Serial Communication** screen to view the properties of the serial communication port.

You can view the **Serial Communication** screen by clicking **System Setup Main Menu > System BIOS > Serial Communication**.

The **Serial Communication** screen details are explained below.

Menu Item	Description
<b>Serial Communication</b>	Selects serial communication devices (Serial Device 1 and Serial Device 2) in the BIOS. BIOS console redirection can also be enabled and the port address can be specified. By default, <b>Serial Communication</b> option is set to <b>Auto</b> .
<b>Serial Port Address</b>	Enables you to set the port address for serial devices. By default, the <b>Serial Port Address</b> option is set to <b>Serial Device 1=COM2, Serial Device 2=COM1</b> . <b>NOTE: Only Serial Device 2 can be used for Serial Over LAN (SOL). To use console redirection by SOL, configure the same port address for console redirection and the serial device.</b>
<b>External Serial Connector</b>	Enables you to associate the external serial connector to serial device 1, serial device 2, or remote access device. By default, the <b>External Serial Connector</b> option is set to <b>Serial Device1</b> . <b>NOTE: Only Serial Device 2 can be used for SOL. To use console redirection by SOL, configure the same port address for console redirection and the serial device.</b>
<b>Failsafe Baud Rate</b>	Displays the failsafe baud rate for console redirection. The BIOS attempts to determine the baud rate automatically. This failsafe baud rate is used only if the attempt fails and the value must not be changed. By default, the <b>Failsafe Baud Rate</b> option is set to <b>115200</b> .
<b>Remote Terminal Type</b>	Sets the remote console terminal type. By default, the <b>Remote Terminal Type</b> option is set to <b>VT 100/VT 220</b> .
<b>Redirection After Boot</b>	Enables or disables the BIOS console redirection when the operating system is loaded. By default, the <b>Redirection After Boot</b> option is set to <b>Enabled</b> .





# System Profile Settings screen details

You can use the **System Profile Settings** screen to enable specific system performance settings such as power management.

You can view the **System Profile Settings** screen by clicking **System Setup Main Menu > System BIOS > System Profile Settings**.

The **System Profile Settings** screen details are explained as follows:

Menu Item	Description
<b>System Profile</b>	Sets the system profile. If you set the <b>System Profile</b> option to a mode other than <b>Custom</b> , the BIOS automatically sets the rest of the options. You can only change the rest of the options if the mode is set to <b>Custom</b> . By default, the <b>System Profile</b> option is set to <b>Performance Per Watt Optimized (DAPC)</b> . DAPC is Dell Active Power Controller. <b>NOTE: The following parameters are available only when the System Profile is set to Custom.</b>
<b>CPU Power Management</b>	Sets the CPU power management. By default, the <b>CPU Power Management</b> option is set to <b>System DBPM (DAPC)</b> . DBPM is Demand-Based Power Management.
<b>Turbo Boost</b>	Enables or disables the processor to operate in turbo boost mode. By default, the <b>Turbo Boost</b> option is set to <b>Enabled</b> .
<b>Energy Efficient Turbo</b>	Enables or disables the <b>Energy Efficient Turbo</b> . Energy Efficient Turbo (EET) is a mode of operation where a processor's core frequency is adjusted within the turbo range based on workload.
<b>C1E</b>	Enables or disables the processor to switch to a minimum performance state when it is idle. By default, the <b>C1E</b> option is set to <b>Enabled</b> .
<b>C States</b>	Enables or disables the processor to operate in all available power states. By default, the <b>C States</b> option is set to <b>Enabled</b> .

Menu Item	Description
<b>Memory DDR Freq Limit</b>	Max performance is enabled.
<b>Collaborative CPU Performance Control</b>	Enables or disables the CPU power management. When set to <b>Enabled</b> , the CPU power management is controlled by the OS DBPM and the System DBPM (DAPC). By default, the option is set to <b>Disabled</b> .
<b>Memory Patrol Scrub</b>	Sets the memory patrol scrub frequency. By default, the <b>Memory Patrol Scrub</b> option is set to <b>Standard</b> .
<b>Memory Refresh Rate</b>	Sets the memory refresh rate to either 1x or 2x. By default, the <b>Memory Refresh Rate</b> option is set to <b>1x</b> .
<b>Uncore Frequency</b>	Selects the <b>Processor Uncore Frequency</b> .  Dynamic mode allows the processor to optimize power resources across the cores and uncore during runtime. The optimization of the uncore frequency to either save power or optimize performance is influenced by the setting of the <b>Energy Efficiency Policy</b> .
<b>Energy Efficient Policy</b>	Selects the <b>Energy Efficient Policy</b> .  The CPU uses the setting to manipulate the internal behavior of the processor and determines whether to target higher performance or better power savings.
<b>Number of Turbo Boot Enabled Cores for Processor 1</b>	 <b>NOTE: If there are two processors installed in the system, you see an entry for Number of Turbo Boost Enabled Cores for Processor 2.</b>  Controls the number of turbo boost enabled cores for processor 1. By default, the maximum number of cores is enabled.
<b>Number of Turbo Boot Enabled Cores for Processor 2</b>	 <b>NOTE: If there are two processors installed in the system, you see an entry for Number of Turbo Boost Enabled Cores for Processor 2.</b>  Controls the number of turbo boost enabled cores for processor 1. By default, the maximum number of cores is enabled.
<b>Monitor/Mwait</b>	Enables the Monitor/Mwait instructions in the processor. By default, the Monitor/Mwait option is set to <b>Enabled</b> for all system profiles, except <b>Custom</b> .   <b>NOTE: This option can be disabled only if the C States option in Custom mode is disabled.</b>   <b>NOTE: When C States is enabled in Custom mode, changing the Monitor/Mwait setting does not impact system power/performance.</b>

## System Security settings screen details

You can use the **System Security** screen to perform specific functions such as setting the system password, setup password, and disabling the power button.

You can view the **System Security** screen by clicking **System Setup Main Menu > System BIOS > System Security Settings**.

The **System Security Settings** screen details are explained as follows:

Menu Item	Description
<b>Intel AES-NI</b>	Improves the speed of applications by performing encryption and decryption using the Advanced Encryption Standard Instruction Set and is set to <b>Enabled</b> by default.
<b>System Password</b>	Sets the system password. This option is set to <b>Enabled</b> by default and is read-only if the password jumper is not installed in the system.
<b>Setup Password</b>	Sets the setup password. This option is read-only if the password jumper is not installed in the system.
<b>Password Status</b>	Locks the system password. By default, the <b>Password Status</b> option is set to <b>Unlocked</b> .
<b>TPM Security</b>	 <b>NOTE: The TPM menu is available only when the TPM module is installed.</b>

Menu Item	Description
	Allows you to control the reporting mode of the Trusted Platform Module (TPM). By default, the <b>TPM Security</b> option is set to <b>Off</b> . You can only modify the TPM Status, TPM Activation, and Intel TXT fields if the <b>TPM Status</b> field is set to either <b>On with Pre-boot Measurements</b> or <b>On without Pre-boot Measurements</b> .
<b>TPM Information</b>	Changes the operational state of the TPM. By default, the <b>TPM Activation</b> option is set to <b>No Change</b> .
<b>TPM Status</b>	Displays the TPM status.
<b>TPM Command</b>	 <b>CAUTION: Clearing the TPM results in the loss of all keys in the TPM. The loss of TPM keys may affect booting to the operating system.</b> Clears all the contents of the TPM. By default, the <b>TPM Clear</b> option is set to <b>No</b> .
<b>Intel TXT</b>	Enables or disables the Intel Trusted Execution Technology (TXT). To enable <b>Intel TXT</b> , Virtualization Technology must be enabled and TPM Security must be <b>Enabled</b> with Pre-boot measurements. By default, the <b>Intel TXT</b> option is set to <b>Off</b> .
<b>Power Button</b>	Enables or disables the power button on the front of the system. By default, the <b>Power Button</b> option is set to <b>Enabled</b> .
<b>NMI Button</b>	Enables or disables the NMI button on the front of the system. By default, the <b>NMI Button</b> option is set to <b>Disabled</b> .
<b>AC Power Recovery</b>	Sets how the system reacts after AC power is restored to the system. By default, the <b>AC Power Recovery</b> option is set to <b>Last</b> .
<b>AC Power Recovery Delay</b>	Sets how the system supports staggering of power up after AC power is restored to the system. By default, the <b>AC Power Recovery Delay</b> option is set to <b>Immediate</b> .
<b>User Defined Delay (60s to 240s)</b>	Sets the <b>User Defined Delay</b> when the <b>User Defined</b> option for <b>AC Power Recovery Delay</b> is selected.
<b>UEFI Variable Access</b>	Provides varying degrees of securing UEFI variables. When set to <b>Standard</b> (the default) UEFI variables are accessible in the Operating System per the UEFI specification. When set to <b>Controlled</b> , selected UEFI variables are protected in the environment and new UEFI boot entries are forced to be at the end of the current boot order.
<b>Secure Boot</b>	Enables Secure Boot, where the BIOS authenticates each pre-boot image using the certificates in the Secure Boot Policy. Secure Boot is disabled by default.
<b>Secure Boot Policy</b>	When Secure Boot policy is <b>Standard</b> , the BIOS uses the system manufacturer's key and certificates to authenticate pre-boot images. When Secure Boot policy is <b>Custom</b> , the BIOS uses the user-defined key and certificates. Secure Boot policy is <b>Standard</b> by default.
<b>Secure Boot Policy Summary</b>	Views the list of certificates and hashes that secure boot uses to authenticated images.

## Secure Boot Custom Policy Settings

Secure Boot Custom Policy Settings is displayed only when **Secure Boot Policy** is set to **Custom**.

In the **System Setup Main Menu**, click **System BIOS > System Security > Secure Boot Custom Policy Settings**.

The **Secure Boot Custom Policy Settings** screen details are explained as follows:

Menu Item	Description
<b>Platform Key</b>	Imports, exports, deletes, or restores the platform key (PK).
<b>Key Exchange Key Database</b>	Allows you to import, export, delete, or restore entries in the Key Exchange Key (KEK) Database
<b>Authorized Signature Database</b>	Imports, exports, deletes, or restores entries in the Authorized Signature Database (db).
<b>Forbidden Signature Database</b>	Imports, exports, deletes, or restores entries in the Forbidden Signature Database (dbx).

# Miscellaneous Settings screen details

You can use the **Miscellaneous Settings** screen to perform specific functions such as updating the asset tag, and changing the system date and time.

You can view the **Miscellaneous Settings** screen by clicking **System Setup Main Menu > System BIOS > Miscellaneous Settings**.

The **Miscellaneous Settings** screen details are explained as follows:

Menu Item	Description
<b>System Time</b>	Enables you to set the time on the system.
<b>System Date</b>	Enables you to set the date on the system.
<b>Asset Tag</b>	Displays the asset tag and enables you to modify it for security and tracking purposes.
<b>Keyboard NumLock</b>	Enables you to set whether the system boots with the NumLock enabled or disabled. By default the <b>Keyboard NumLock</b> is set to <b>On</b> .  <b>NOTE: This option does not apply to 84-key keyboards.</b>
<b>F1/F2 Prompt on Error</b>	Enables or disables the F1/F2 prompt on error. By default, <b>F1/F2 Prompt on Error</b> is set to <b>Enabled</b> . The F1/F2 prompt also includes keyboard errors.
<b>Load Legacy Video Option ROM</b>	Enables you to determine whether the system BIOS loads the legacy video (INT 10H) option ROM from the video controller. Selecting <b>Enabled</b> in the operating system does not support UEFI video output standards. This field is only for UEFI boot mode. You cannot set this to <b>Enabled</b> if <b>UEFI Secure Boot</b> mode is enabled.
<b>In-System Characterization</b>	This option enables or disables <b>In-System Characterization</b> . By default, <b>In-System Characterization</b> is set to <b>Enabled - No Reboot</b> . The two other options are <b>Enabled</b> and <b>Disabled</b> .  When enabled, In-System Characterization (ISC) executes during POST upon detecting relevant change(s) in system configuration to optimize system power and performance. ISC takes about 20 seconds to execute, and system reset is required for ISC results to be applied. The <b>Enabled - No Reboot</b> option executes ISC and continues without applying ISC results until the next time system reset occurs. The <b>Enabled</b> option executes ISC and forces an immediate system reset so that ISC results can be applied. It takes the system longer to be ready due to the forced system reset. When disabled, ISC does not execute.
<b>Dell Wyse P25BIOS Access</b>	This option is enabled by default.
<b>Debug Menu</b>	Debug Error Lever — Reboot Text Mode — <b>off (default)</b> Cold Reboot Power cycle Reboot Test Point Memory disabled by default. PCI Init Complete Embedded SATA test mode — <b>Disabled (Default)</b> Spread Spectrum — Disabled Embedded SATA RSTe Debug — Disabled MRC Serial Debug Output — Disabled DFx Margining — Disabled TXEQ PCIe Workaround — <b>Enabled (default)</b> Miscellaneous .Device Unhide — Disabled Memory RMT — Disabled



## NIC indicator codes

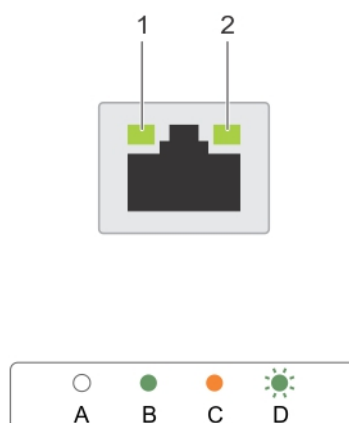

**Figure 48. NIC indicators**

1. link indicator
2. activity indicator

**Table 24. NIC indicators**

Convention	Indicator	Indicator code
A	Link and activity indicators are off	The NIC is not connected to the network.
B	Link indicator is green	The NIC is connected to a valid network at its maximum port speed (1 Gbps or 10 Gbps).
C	Link indicator is amber	The NIC is connected to a valid network at less than its maximum port speed.
D	Activity indicator is blinking green	Network data is being sent or received.

## Power indicator codes

Each AC power supply unit (PSU) has an illuminated translucent handle and each DC power supply unit (when available) has an LED that serves as an indicator to show whether power is present or a power fault has occurred.



**Figure 49. AC power supply unit status indicator**

1. AC power supply unit status indicator/handle

Convention	Power indicator pattern	Condition
A	Green	The handle indicator lights green indicating that a valid power source is connected to the power supply unit and that the power supply unit is operational.
B	Flashing green	When updating the firmware of the power supply unit, the power supply unit handle flashes green.
C	Flashing green and turns off	When hot-adding a power supply unit (PSU), the power supply unit handle flashes green five times at 4 Hz rate and turns off. This indicates that the power supply unit is mismatched with the other power supply unit (in terms of efficiency, feature set, health status, and supported voltage). Replace the power supply unit that has the flashing indicator with a power supply unit that matches the capacity of the other installed power supply unit. <b>NOTE:</b> For AC power supplies, use only PSUs with the Extended Power Performance (EPP) label on the back. Mixing PSUs from previous generations of servers can result in a PSU mismatch condition or failure to power on.
D	Flashing amber	Indicates a problem with the power supply unit. <b>CAUTION:</b> When correcting a power supply unit mismatch, replace only the power supply unit with the flashing indicator. Swapping the opposite power supply unit to make a matched pair can result in an error condition and unexpected system shutdown. To change from a High Output configuration to a Low Output configuration or vice versa, you must power down the system.

Convention	Power indicator pattern	Condition
		<p>⚠ <b>CAUTION:</b> AC power supplies support both 220 V and 110 V input voltages with the exception of Titanium power supplies, which support only 220 V. When two identical power supplies receive different input voltages, they can output different wattages, and trigger a mismatch.</p> <p>⚠ <b>CAUTION:</b> If two power supplies are used, they must be of the same type and have the same maximum output power.</p> <p>⚠ <b>CAUTION:</b> Combining AC and DC power supplies is not supported and triggers a mismatch.</p>
E	Not lit	Power is not connected.

# Contacting Dell

## Topics:

- [Contacting Dell](#)
- [Quick Resource Locator \(QRL\)](#)

## Contacting Dell

**NOTE:** If you do not have an active Internet connection, you can find contact information on your purchase invoice, packing slip, bill, or Dell product catalog.

Dell provides several online and telephone-based support and service options. Availability varies by country and product, and some services may not be available in your area. To contact Dell for sales, technical support, or customer service issues:

1. Go to **Dell.com/support**.
2. Select your support category.
3. Verify your country or region in the **Choose a Country/Region** drop-down list at the bottom of the page.
4. Select the appropriate service or support link based on your need.

## Quick Resource Locator (QRL)

Use the Quick Resource Locator (QRL) to get immediate access to system information and how-to videos. This can be done by visiting **dell.com/QRL** or by using your smartphone or tablet and a model specific Quick Resource (QR) code located on your Dell Precision Workstation Racksystem. To try out the QR code, scan the following image.

