

DELL™

# POWEREDGE™ T410

TECHNICAL GUIDEBOOK  
INSIDE THE POWEREDGE T410



# Table of Contents

1	Product Comparison.....	1
1.1	Overview/Description .....	1
2	New Technologies.....	3
2.1	New Technologies Used in the PowerEdge T410.....	3
3	System Overview .....	3
3.1	Overview/Description .....	3
3.2	Product Features Summary .....	4
4	Mechanical.....	7
4.1	Chassis Description .....	7
4.2	Dimensions and Weight .....	7
4.3	Front Panel View and Features .....	8
4.4	Back Panel View and Features .....	11
4.5	Power Supply Indicators.....	12
4.6	NIC Indicators .....	12
4.7	Side Views and Features .....	13
4.8	Internal Chassis Views .....	14
4.9	Rails and Cable Management .....	16
4.10	Fans.....	17
4.11	Control Panel/LCD .....	17
4.12	Security.....	17
4.12.1	Cover Latch.....	17
4.12.2	Bezel.....	19
4.12.3	Hard Drive.....	19
4.12.4	Trusted Platform Management .....	20
4.12.5	Power-Off Security .....	20
4.12.6	Intrusion Alert.....	20
4.12.7	Secure Mode.....	20
4.13	USB Peripherals.....	20
4.14	Battery .....	21
4.15	Field Replaceable Units (FRU).....	21
5	Electrical .....	22
5.1	Volatility .....	22
5.2	ePPID .....	22
6	Power, Thermal, and Acoustic.....	23
6.1	Power Supplies .....	23
6.2	Power Supply Specifications .....	24
6.3	Environmental Specifications .....	26
6.4	Maximum Input Amps.....	27
6.5	Energy Star Compliance .....	27
6.6	Acoustics.....	27
7	Block Diagram.....	28
8	Processors .....	31
8.1	Overview.....	31

8.2	Supported Processors.....	31
8.3	Processor Configurations.....	32
8.4	Processor Installation.....	33
8.5	Overview/Description.....	33
8.6	DIMM Types Supported.....	33
8.7	Slots/Risers.....	33
8.8	Mirroring.....	34
8.9	RAID.....	34
9	Chipset.....	34
9.1	Overview/Description.....	34
10	BIOS.....	35
10.1	Overview/Description.....	35
10.2	Supported ACPI States.....	36
10.3	11G BIOS Power Management.....	36
10.4	I <sup>2</sup> C (Inter-Integrated Circuit).....	37
11	Embedded NICs/LAN on Motherboard (LOM).....	37
11.1	Overview/Description.....	37
12	I/O Slots.....	38
12.1	Overview/Description.....	38
12.2	Quantities and Priorities.....	38
12.3	Boot Order.....	39
13	Storage.....	39
13.1	Overview/Description.....	39
13.2	Drives.....	40
13.3	RAID Configurations.....	40
13.4	Storage Controllers.....	42
13.5	LED Indicators.....	42
13.6	Optical Drives.....	42
13.7	Tape Drives.....	42
14	Video.....	42
14.1	Overview/Description.....	42
15	Audio.....	43
15.1	Overview/Description.....	43
16	Rack Information.....	43
17	Operating Systems.....	43
18	Virtualization.....	45
18.1	Overview/Description.....	45
19	Systems Management.....	45
19.1	Overview/Description.....	45
19.2	Server Management.....	46
19.3	Embedded Server Management.....	46
19.4	Lifecycle Controller and Unified Server Configurator.....	46
19.5	iDRAC Express.....	47
19.6	iDRAC6 Enterprise.....	47
20	Peripherals.....	49

20.1	USB Peripherals.....	49
20.2	External Storage .....	49
21	Packaging Options .....	49

# 1 Product Comparison

## 1.1 Overview/Description

The PowerEdge T410 is a two-socket tower server that delivers the most flexible configuration options to fulfill different business and customer needs and maximize their IT budget.

T410 provides:

- Up to 2 sockets of Intel Xeon 5500 series processors.
- Dell's Lifecycle Controller available via optional iDRAC Express or iDRAC Enterprise
- Competitive security features with TPM, internal USB and IPv6
- Competitive storage expandability and with up to 6 x 3.5" hard disk drives
- Excellent serviceability and diagnostics with optional interactive LCD
- A chassis depth of only 24" for deployment flexibility.

**Table 1. Comparison of T410 to T605 and T610**

Feature/Spec	T410	T605 (Predecessors)	T610 (Next level up)
<b>Processor</b>	2S Intel® Xeon® processor 5500 series	AMD Opteron 2XXX series	2S Intel Xeon processor 5500 series
<b>Front Side Bus</b>	QPI @ 6.4 GT/s	1GBz HyperTransport	QPI @ 6.4 GT/s
<b># Procs</b>	1 to 2	1 or 2	1 to 2
<b># Cores</b>	Dual or Quad	Dual or Quad	Dual or Quad
<b>L2/L3 Cache</b>	4 MB or 8 MB		4 MB or 8 MB
<b>Chipset</b>	Intel 5500 chipset	HT2100 + HT1000	Intel 5520 chipset
<b>DIMMs</b>	4+4 DDR3 Unbuffered w/ECC or Registered w/ECC 1333/1066/800MHz	8 DDR2 Registered w/ECC 667MHz	6+6 DDR3 Unbuffered w/ECC or Registered w/ECC 1333/1066/800MHz
<b>Min/Max RAM</b>	1 GB/64 GB	512 MB/32 GB	1 GB/96 GB
<b>HD Bays</b>	6 x 3.5" Optional Hot-swap Support 2.5" Hard disk drives via Hot-swap tray	4 x 3.5" Optional Hot-swap	8 x 2.5"/3.5" Hot-swap
<b>HD Types</b>	Default SATA. Optional SAS and SSD via add-in controller	Default SATA. Optional SAS via add-in controller	Default SATA or SAS
<b>Ext Drive Bay(s)</b>	2 x 5.25" bay	2 x 5.25" bay 1x 3.5" bay	2 x 5.25" bay
<b>Embedded HD Controller</b>	Chipset based SATA	Chipset based SATA	SAS 6/iR

Feature/Spec	T410	T605 (Predecessors)	T610 (Next level up)
<b>Optional Storage Controller</b>	<p>NON-RAID: SAS 5/E LSI 2032 (For TBU only) SAS 6/E</p> <p>RAID: SAS 6/iR Adapter PERC 6/i PERC 6/E</p>	<p>SAS 5/iR SAS 6/iR PERC 6/i</p>	<p>NON-RAID: SAS 5/E LSI 2032 (For TBU only)</p> <p>RAID: SAS 6/iR (Default) PERC 6/i PERC 6/E</p>
<b>Availability</b>	Hot-swap hard disk drives; Redundant PSU; Quad-pack LED diagnostic/LCD with Hot-swap hard disk drives chassis; Memory mirroring	Tool-less chassis; LCD diagnostic	Hot-swap hard disk drives; Redundant PSU; LCD diagnostic; Memory mirroring or sparing; Internal SD card for embedded Hypervisor
<b>Server Mgt.</b>	BMC, IPMI 2.0 compliant; Full Open Manage suite Optional; iDRAC6 Express, iDRAC6 Enterprise, Vflash	BMC, IPMI 2.0 compliant; Dell Server Assistant Optional; DRAC5	iDRAC 6 Express, BMC, IPMI 2.0 compliant; Full Open Manage suite Optional; iDRAC6 Enterprise, Vflash
<b>I/O Slots</b>	<p>Slot 1: PCI-E x8 connector(x4 routing, half length → Gen 2.)</p> <p>Slot 2: PCI-E x8 connector(x4 routing, full length → Gen 2.)</p> <p>Slot 3: PCI-E x8 connector(x4 routing, full length → Gen 1.)</p> <p>Slot 4: PCI-E x8 connector(x4 routing, half length → Gen 2.)</p> <p>Slot 5: PCI-E x16 connector(x8 routing, half length → Gen 2.)</p>	<p>1 x PCIe x8 3 x PCIe x4 1 x PCI-X 64/133</p>	<p>2x PCIe x8; 3x PCIe x 4 Gen 2</p>
<b>RAID</b>	See optional Storage Controller	See optional Storage Controller	See optional Storage Controller
<b>NIC/LOM</b>	2x GbE LOM Optional: various NIC available	1x GbE LOM Optional: various NIC available	2x GbE LOM w/ TOE Optional: various NIC available
<b>USB</b>	Two front/four rear/two internal	Two front/five rear	Two front/two rear/one internal
<b>Hypervisor (via internal SD card)</b>	No	No	Yes

Feature/Spec	T410	T605 (Predecessors)	T610 (Next level up)
<b>Power Supplies</b>	Non-Redundant, 525W (80+ SILVER) Optional Redundant, 580W (80+ GOLD) Auto Ranging (100V~240V)	Non-Redundant, 650W Optional Redundant, 675W (1+1)	Redundant, 870W High Efficiency PSU or 570W High capacity PSU
<b>Fans</b>	Non-redundant, non-hot swappable	Non-redundant, non-hot swappable	Redundant, Hot swappable
<b>Form Factor</b>	Tower	Tower	Tower
<b>Dimension (HxWxD)</b>	444.9 x 217.9 x 616.8 (mm) (w/ foot, bezel) 17.52 x 8.58 x 24.28 (in)	456 x 272 x 635 (mm) (w/ foot, bezel) 17.97 x 10.71 x 25 (in)	441.0 x 274.0 x 621.0 (mm) (w/foot, bezel, PSU) 17.40 x 10.80 x 24.40 (in)
<b>Weight</b>	Max: 62.61lbs (28.4Kg)	Max: 59.5lbs (27Kg)	Max: 77lbs (35Kg)

## 2 New Technologies

### 2.1 New Technologies Used in the PowerEdge T410

- Intel 5500 chipset along with Intel Xeon 5500 series processors
- DDR3 memory configuration
- iDRAC6 (new Dell server remote management controller)
- SSD Drive options (support SSD drives)

## 3 System Overview

### 3.1 Overview/Description

The T410 is a two-socket tower product that delivers the most competitive feature set below the \$750 entry-level cost point. It is positioned to compete against the HP ML150 and IBM x3400 servers.

The T410 provides:

- Outstanding price and feature set combination
- Industry leading feature flexibility and configurability
- Industry leading server management with LifeCycle Controller available via optional iDRAC Express or iDRAC Enterprise
- Industry leading security features with TPM, internal USB and IPv6
- Competitive storage expandability and \$/GB with 6 x 3.5"/2.5" HDD
- Industry leading serviceability and diagnostics with optional interactive LCD
- Industry leading chassis depth of only 24" in its class for SMB closets, back office and under the desk environment

## 3.2 Product Features Summary

**Table 2. T410 Product Features**

Features	Descriptions
Chipset	Intel 5500 chipset
CPU	Intel Xeon 5500 series processors
DIMM	4+4 DDR3 Unbuffered w/ECC or Registered w/ECC 1333/1066/800MHz
Memory Modules	1 GB UDIMM/RDIMM 2 GB UDIMM/RDIMM 4 GB RDIMM 8 GB RDIMM
TPM	TPM TCM/NO TPM
Expansion Slots	5 PCI slots Slot 1: PCIe x8 (x4 routing, Gen2), half length Slot 2: PCIe x8 (x4 routing, Gen2), full length Slot 3: PCIe x8 (x4 routing, Gen 1), full length Slot 4: PCIe x8 (x4 routing, Gen2), half length Slot 5: PCIe x16 (x8 routing, Gen2), half length
LOM	Two GbE (5716 dual port) w/o TOE
Management	Full Open Manage BMC, IPMI2.0 compliant Optional: iDRAC6-Express, iDRAC6-Enterprise and Vflash
USB	Two front/four rear/four internal
PSU	Non-Redundant, 525W (80+ BRONZE) Optional Redundant, 580W (80+ GOLD) Auto Ranging (100V~240V)
Availability	Quad-pack LED diagnostic/LCD with hot-swap hard disk drives chassis
Embedded Graphics	Matrox G200eW with up to 16 MB memory
Resolution and Colors	1280x1024@85Hz for KVM and 1600x1200@60Hz for video out 640x480 (60/72/75/85 Hz; 8/16/32-bit color) 800x600 (60/72/75/85 Hz; 8/16/32-bit color) 1024x768 (60/72/75/85 Hz; 8/16/32-bit color) 1152x864 (75 Hz; 8/16/32-bit color) 1280x1024 (60/75/85 Hz; 8/16-bit color) 1280x1024 (60 Hz, 32-bit color) (32 bit color is only supported at 60 Hz for this resolution)
Audio	No Speaker/No Buzzer
Form Factor	Tower (5U rack via 3rd party tray)
Dimension (HxWxD)	444.9 x 217.9 x 616.8 (mm) (w/ bezel, w/ tower foot) 17.52 x 8.58 x 24.28 (in)
Max Weight	28.4 Kg/62.61 lbs



Features	Descriptions
Bezel	Plastic (Default)
Hard Disk Drives Bay Options	6x 3.5" Optional Hot-Swap Support 2.5" hard disk drives via Hot-swap tray
Hard Disk Drives/SATA Options	<b>3.5"/7.2 K</b> 160 GB 250 GB 500 GB 750 GB 1000 GB 2000 GB (POST-RTS)
Hard Disk Drives/Near Line SAS Options	<b>3.5"/7.2 K</b> 500 GB 750 GB 1000 GB 2000 GB (POST-RTS)
Hard Disk Drives/SAS Options	<b>3.5"/15 K</b> 146 GB 300 GB 450 GB  <b>3.5"/10 K</b> 600 GB  <b>2.5"/10 K</b> (in 3.5" Hot Plug HDD Carrier) 73 GB 146 GB 300 GB
HARD DISK DRIVE/SSD Options	<b>2.5"</b> (in 3.5" Hot Plug HDD Carrier) 25 GB SATA SSD 50 GB SATA SSD 100 GB SATA SSD (POST-RTS)
Media Bay	2x 5.25"
Remote Drive Options	DVD-ROM DVD+/-RW USB DVD-ROM
Backup Device Options	RD1000 (Internal and External) DATA-72 (Internal and External) LTO2-L (Internal and External) LTO3-060 (Internal and External) LTO3FH (External) LTO4-120 HH (Internal and External) LTO4-120 FH (External) PV114T (External, 2U)
Tape Automation Options	TL2000/TL4000 ML6000 PV124T

Features	Descriptions
TBU Software Options	CommVault Galaxy Symantec Backup Exec including Backup Exec System Recovery Yosemite/Little Man
PV DAS/SAN Options	MD1000 MD1120 MD3000/MD300i
Storage HBA Options	<b>NON-RAID:</b> SAS 5/E SAS 5/iR (For TBU only) LSI 2032 (For TBU only)  <b>RAID:</b> SAS 6/iR PERC 6/i PERC 6/E
NICs/Single Port	Intel PRO/1000 PT Server Adapter
NICs/Dual Port	Intel Gigabit ET Dual Port Server Adapter Broadcom NetXtreme II 5709 Dual Port Ethernet PCIe Card with TOE Broadcom NetXtreme II 5709 Dual Port Ethernet PCIe Card with TOE and iSCSI Offload
NICs/Quad Port	Intel Gigabit VT Quad Port Server Adapter Intel Gigabit ET Quad-Port Server Adapter Broadcom NetXtreme II® 5709 Quad Port Ethernet PCIe Card with TOE/iSCSI Offload
Infiniband NIC	N/A
FC HBA	N/A
Solutions Support	<b>Database:</b> SQL2008  <b>Virtualization:</b> VMware® vSphere™ Version 4.0 VMware Virtual Infrastructure 3 ESX/EXSi 3.5 Update 4 (Classic version will be DIB; embedded version is available for download from VMware website and can be installed to the hard drive. Hypervisor is not supported.) Hyper-V (Veridian and standalone Viridian)
Operating System Options	<b>Microsoft:</b> Essential Business Server (Centro) 64-bit Standard(DIB) and Premium(DIB) SBS2008 64-bit Standard and Premium (FI) WS2008 32-bit Standard, Enterprise (FI) WS2008 64-bit Standard, Enterprise, Datacenter (FI) SBS2003 R2 32-bit Standard and Premium(DIB) WS2003 R2 32-bit Standard, Enterprise WS2003 R2 64-bit Standard, Enterprise, Datacenter(DIB)  <b>Linux:</b> RHEL 4.7 ES/AS x86(DIB, NFI) (POST-RTS at Q2 block) RHEL 4.7 ES/AS 64-bit(DIB, NFI) (POST-RTS at Q2 block) RHEL 5.2 Standard/AP x86(DIB, NFI) RHEL 5.2 Standard/AP 64-bit SLES 10 SP2 64-bit(DIB, NFI) SLES 11 64-bit (POST-RTS at Q2 block)

## 4 Mechanical

### 4.1 Chassis Description

The PowerEdge T410 chassis offers the optimum size for growing businesses and large organizations with remote locations.

The new chassis design of the PowerEdge 410 offers cabled hard disk drives (HDDs) or hot-plug hard disk drives. Each is available with redundant Power Supply Units (PSUs) or non-redundant PSUs are options.

The PowerEdge T410 chassis is user friendly. Many of the T410 components devices are tool-less. These tool-less components include HDDs (cabled and hot-plug), fans, extension cards, planar, back plane, and redundant PSUs. The non-redundant PSU uses only three screws to reduce the assembly and service time.

### 4.2 Dimensions and Weight

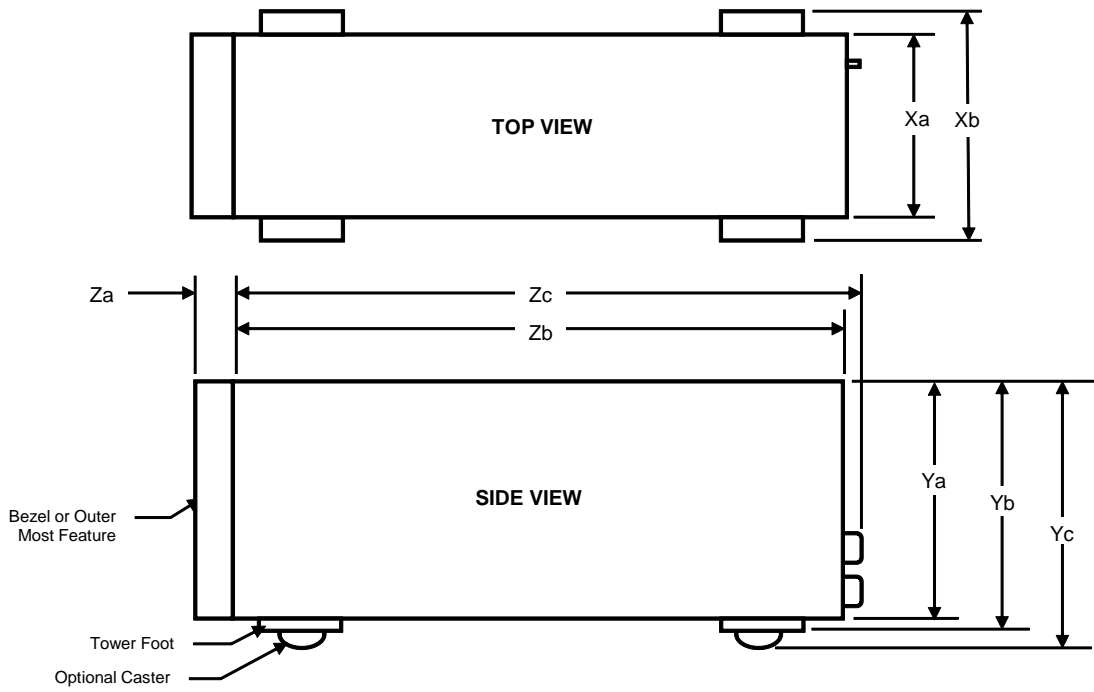

Figure 1. T410 Top and Side Views

Table 3. T410 Dimensions

Dimension ( <i>HxWxD</i> )	444.9 x 217.9 x 616.8 (mm)
(w/foot, w/ bezel)	17.52 x 8.58 x 24.28 (in)
Max Weight	28.4 Kg/62.61 lbs

**Table 4. T410 Detailed Dimensions**

Development Name	Model Number	Xa	Xb	Ya	Yb	Yc	Za w/ bezel	Za w/o bezel	Zb*	Zc	Max Sys Weight
T410	PE T410	217.9	282.5	433.3	444.9	NA	37.0	21.5	574.8	579.8	28.4 Kg/ 62.61 lbs

**Note**

Zb goes to the nominal rear wall external surface where the motherboard I/O connectors reside.

**4.3 Front Panel View and Features**

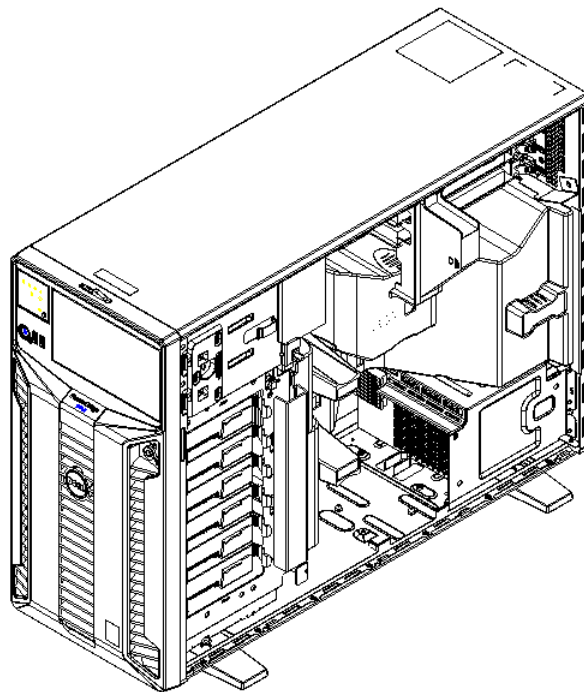

**Figure 2. T410 Transparent Side View**

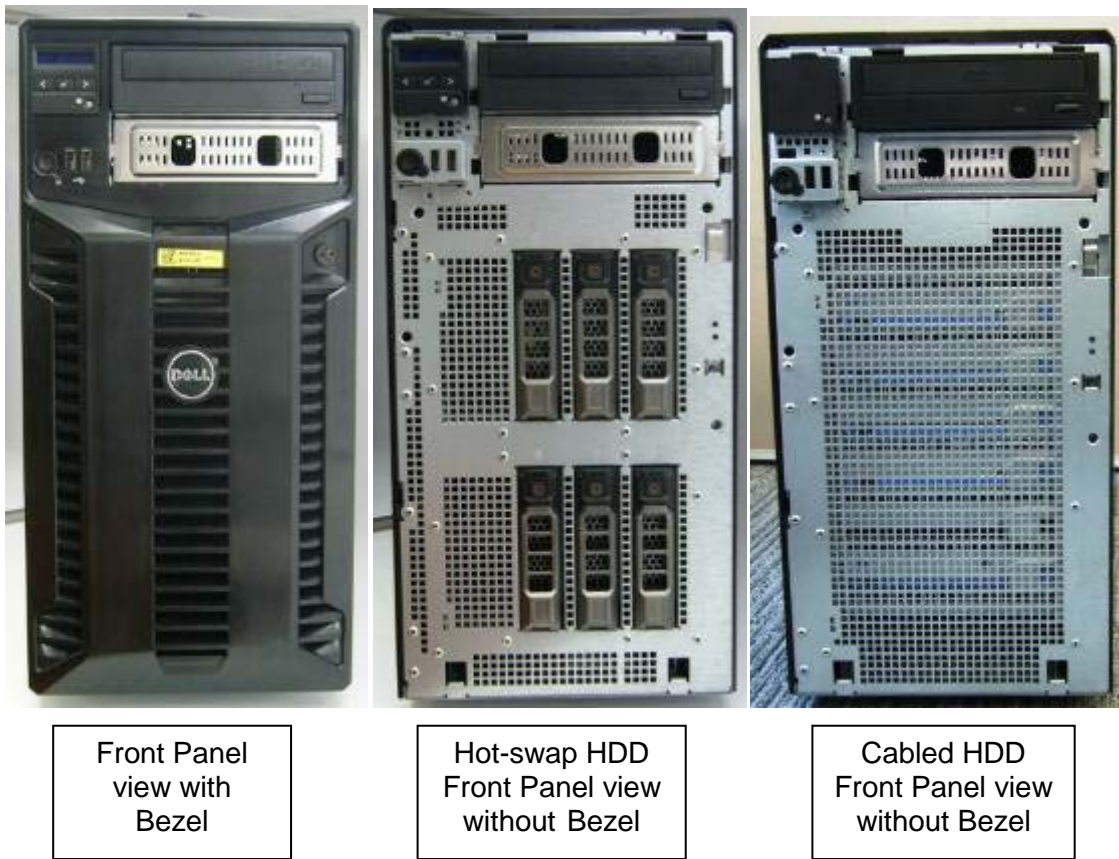

**Figure 3. Front Panel Views With and Without Bezel**

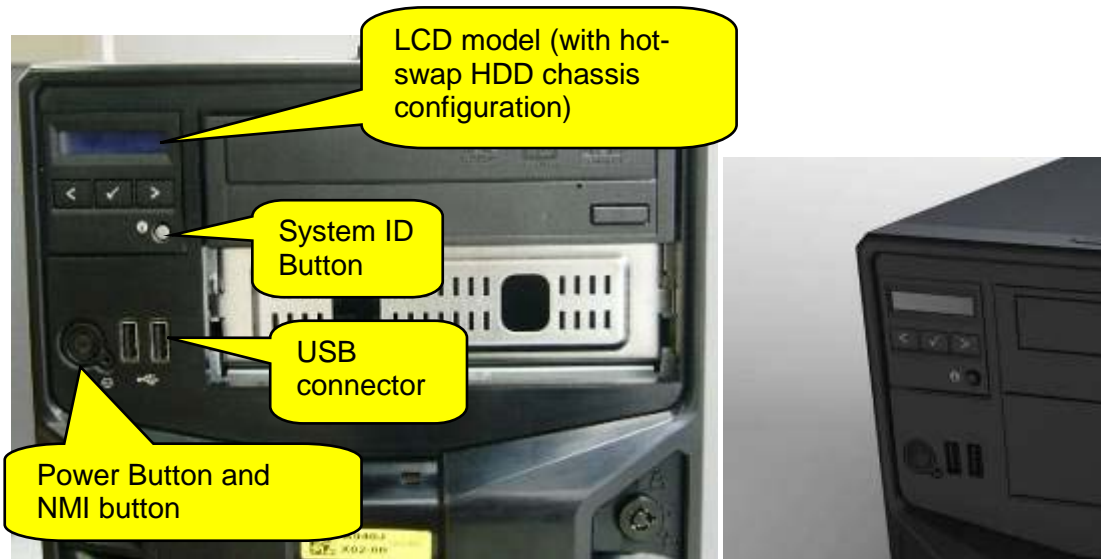

**Figure 4. LCD Model View**

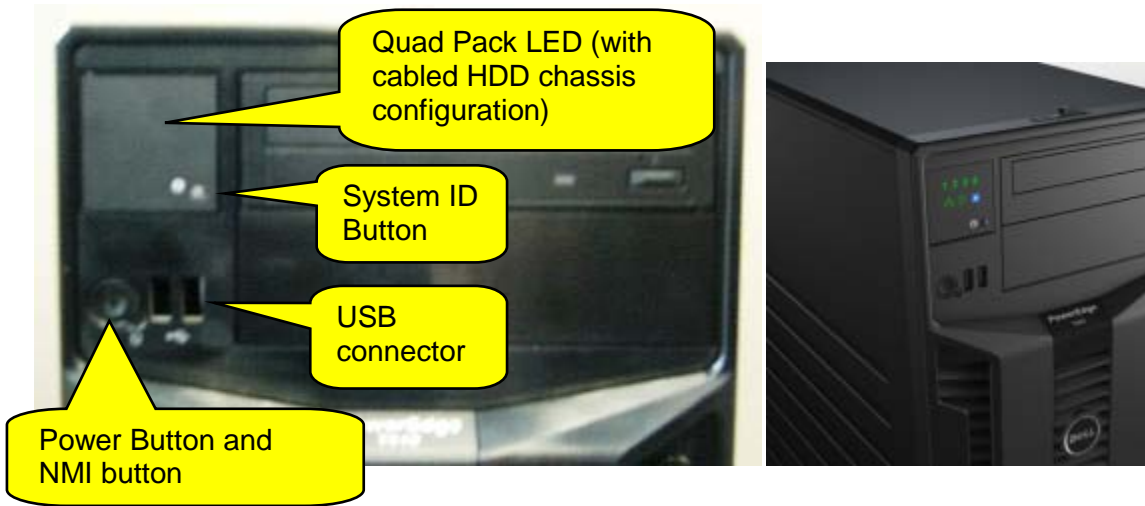

Figure 5. LED Model View

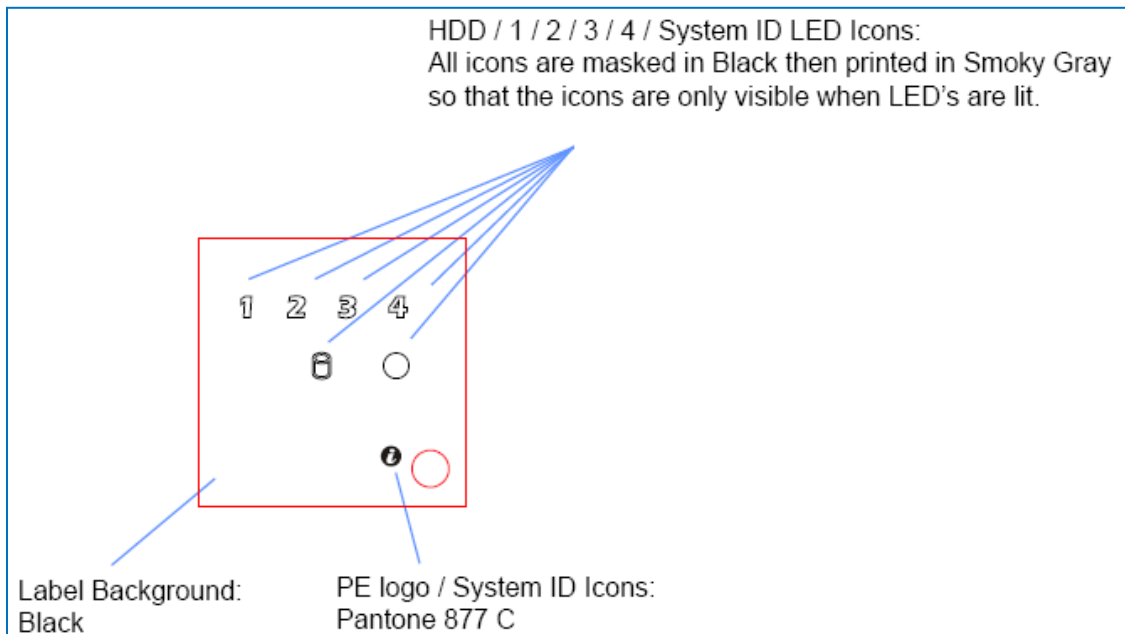
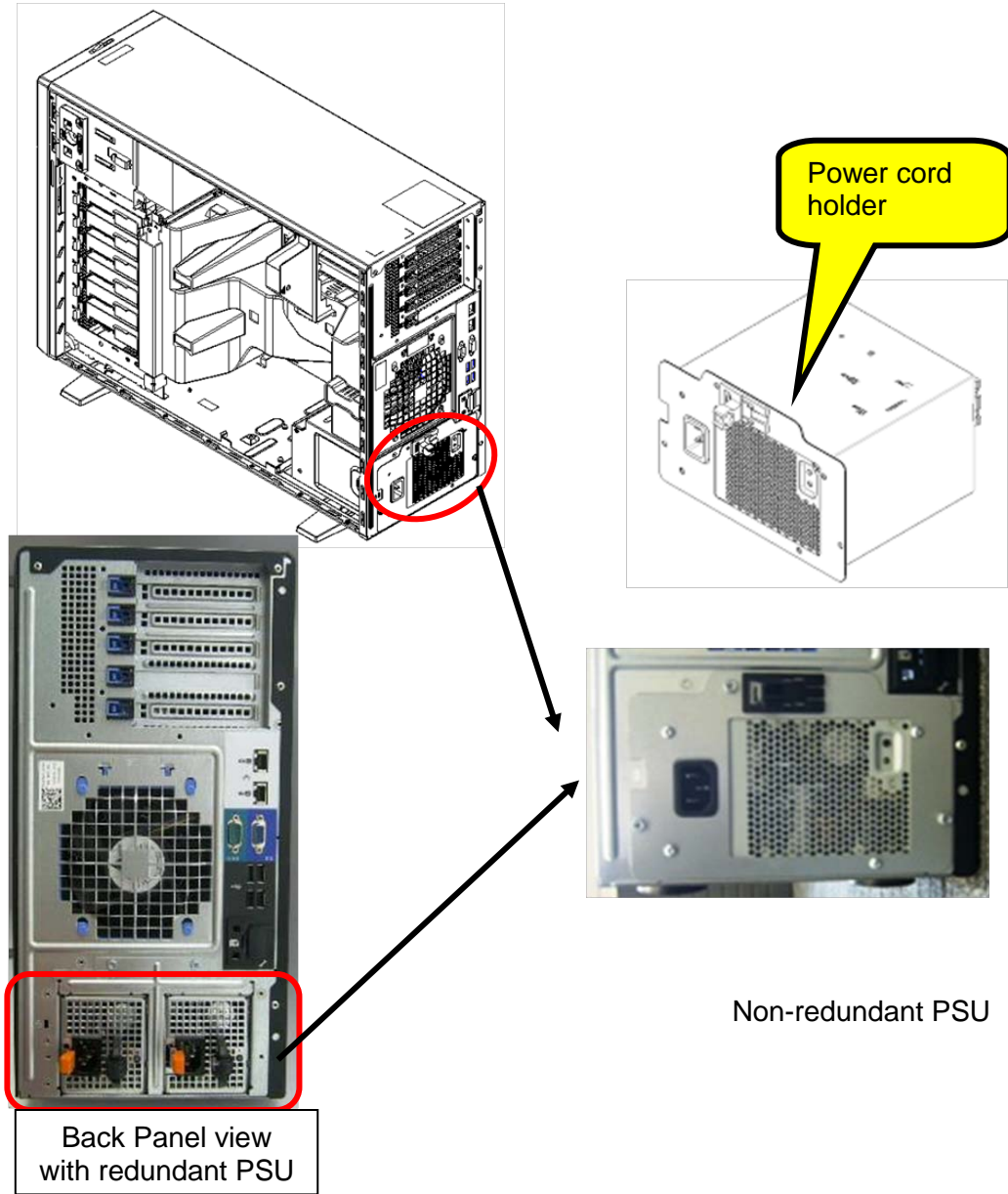

Figure 6. LED Descriptions

## 4.4 Back Panel View and Features



**Figure 7. Back Panel Views of Redundant and Non-redundant PSUs**

## 4.5 Power Supply Indicators

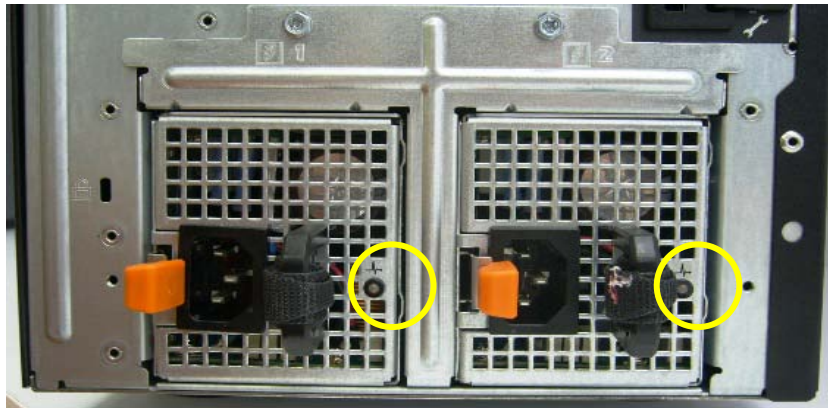

Figure 8. Close-up of Redundant PSU Option

Light indicators:

- Not lit – AC power is not connected.
- Green – In standby mode, a green light indicates a valid AC source is connected to the power supply and it is operational. When the system is on, a green light also indicates the power supply is providing DC power to the system.
- Amber – Indicates a problem with the power supply.
- Alternating green and amber – When hot-adding a power supply, this indicates that the power supply is mismatched with the other power supply (Ex. a High Output 500-W power supply and a 400-W power supply are installed in the same system). Replace the power supply that has the flashing indicator with a power supply that matches the capacity of the other installed power supply.

## 4.6 NIC Indicators

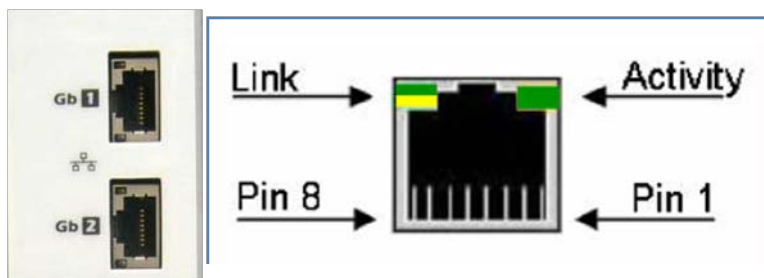

Figure 9. NIC Indicators

Table 5. LED States

State		Link LED (Green/Yellow)	Activity LED (Green)
No link		Off	Off
D0uninitialized (out of box), D3cold, S4 (hibernation)	WOL disabled	Off	Off
	WOL enabled, link, no activity	Green if the port is operating at maximum port speed; Yellow otherwise	Off
	WOL enabled, link, activity	Green if the port is operating at maximum port speed; Yellow otherwise	On (blinking at speed related to packet density)



State		Link LED (Green/Yellow)	Activity LED (Green)
Pre-OS POST or OS without driver	Link, no activity	Green if the port is operating at maximum port speed; Yellow otherwise	Off
	Link, activity		On (blinking at speed related to packet density)
OS with driver	Link, no activity		Off
	Link, activity		On (blinking at speed related to packet density)

## 4.7 Side Views and Features



**Figure 10. Standard Coin Lock Shown**

## 4.8 Internal Chassis Views



Figure 11. Cabled HDD Configuration with Air Shroud

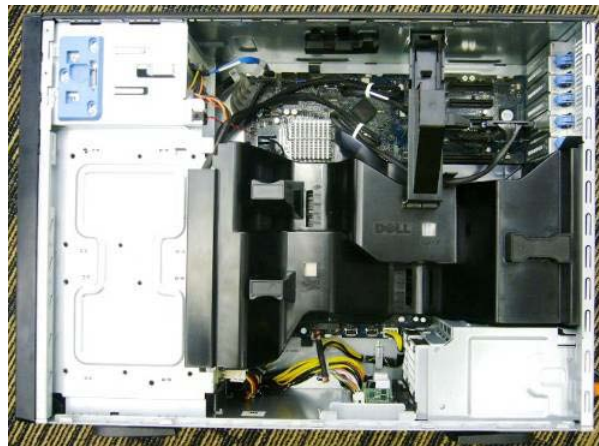

Figure 12. Hot-swap HDD Configuration with Air Shroud



Figure 13. Hot-swap Hard Disk Drives Configuration without Air Shroud



**Figure 14. Backplane for Hot-swap Hard Disk Drives Configuration Option**

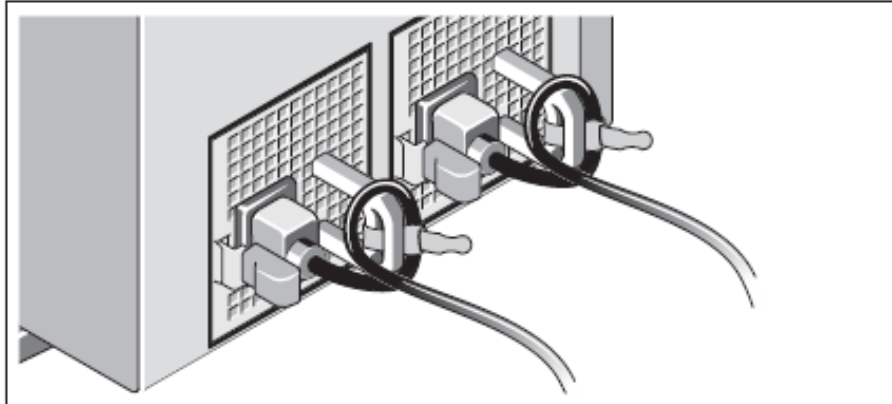

**Figure 15. Power Distribution Board (PDB) for Redundant PSU**

## 4.9 Rails and Cable Management

The PowerEdge T410 is a flexible stand-alone tower and is not rackable.

### Securing the Power Cord



Attach the power cord retention bracket on the right bend of the power supply handle. Bend the system power cable into a loop as shown in the illustration and attach to the bracket's cable clasp.

Plug the other end of the power cables into a grounded electrical outlet or a separate power source such as an uninterruptible power supply (UPS) or a power distribution unit (PDU).

**Figure 16. Power Cord Cable Management for Redundant PSU**

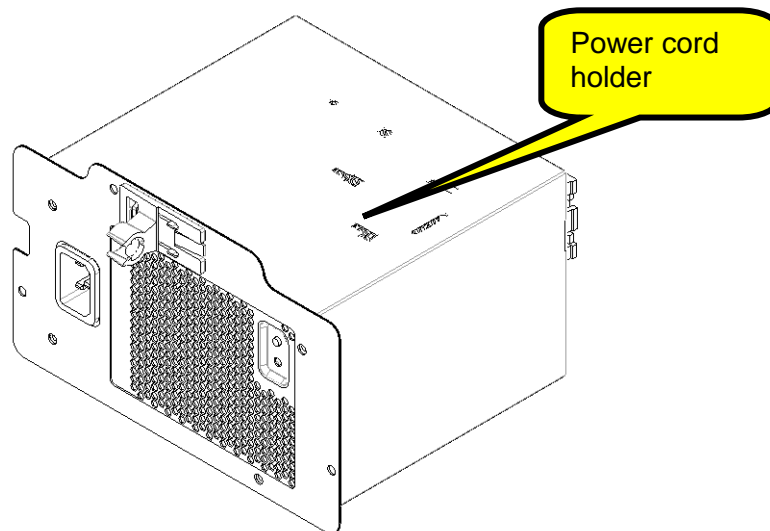

**Figure 17. Power Cord Cable Management for Non-redundant PSU**

## 4.10 Fans

The PowerEdge T410 system fan is located at the rear of the chassis.



Figure 18. PowerEdge T410 System Fan

## 4.11 Control Panel/LCD

Front control panel includes:

- 2x USB
- Diagnostic indicator (11G LCD module)
- NMI button
- Power button
- HDD activity LED
- System ID button

## 4.12 Security

### 4.12.1 Cover Latch

The PowerEdge T4120 bezel lock is located on the front bezel of the chassis. The bezel lock provides security for the system by preventing access to remove/install ODD/TBU and Hot-Plug HDD (Hot-Plug HDD option only).

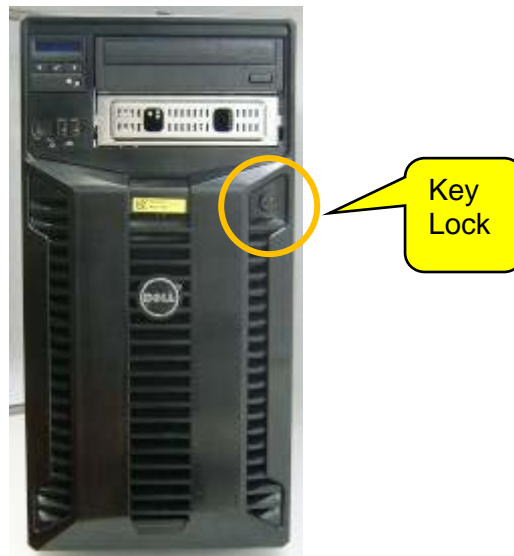

**Figure 19. T410 Key Lock**

The PowerEdge T410 coin lock is located on the front of the right side cover.

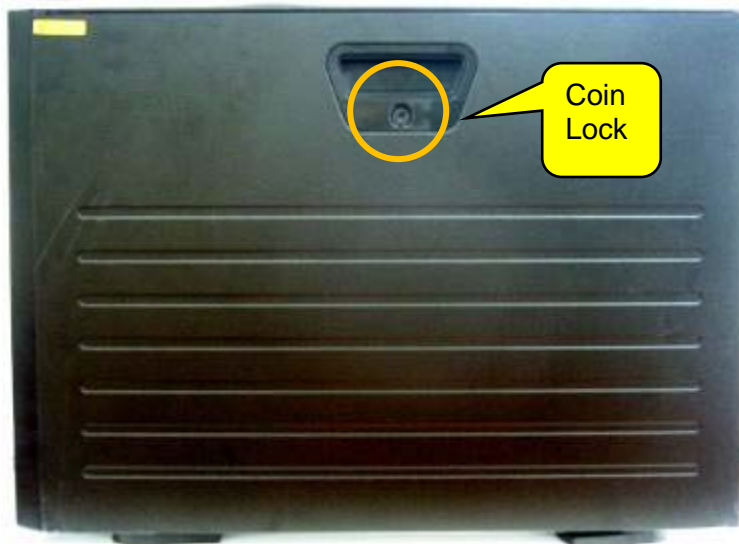

**Figure 20. T410 Coin Lock**

The PowerEdge T410 is also equipped with a Kensington lock located on the rear of the T410 chassis.

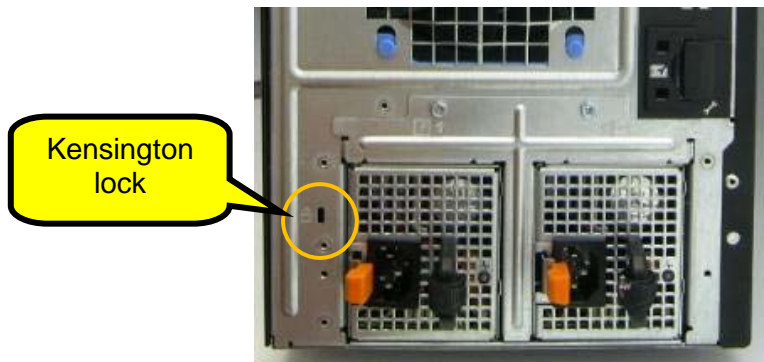

**Figure 21. T410 Kensington Lock**

### 4.12.2 Bezel

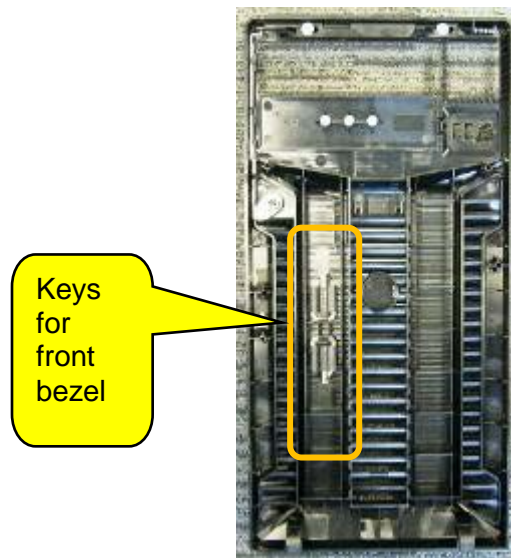
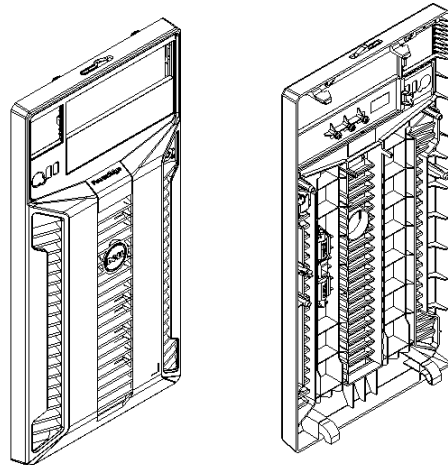

Figure 22. T410 Bezel Keys

### 4.12.3 Hard Drive

The PowerEdge T410 supports up to six 3.5", SATA or SAS Hard Drives. The T410 can also support six hot-swap SAS/SATA hard drives via an optional SAS back plane and RAID controller card. The hot-swap drives utilize the Dell Universal Carrier Design.

The embedded SATA controller from the T410 motherboard chipset (ICH10R) supports up to four SATA drives. SAS controllers are not provided on the T410 motherboard. Cabled SAS drives are connected to a RAID controller PCIe add-on card. For the hot-swap hard drive configuration, an optional hard drive back plane and a RAID controller PCIe add-on card are required.

## 4.12.4 Trusted Platform Management

The PowerEdge trusted platform management (TPM) option is available in most countries.

TPM 1.2 compliant encryption chip solution is on the T410 system board with BIOS support.

- The TPM 1.2 chip is supported with Windows OS in the following usages:
- Microsoft Storage Encryption solution (Bitlocker) with full-drive encryption
- Secure Boot, integrity checking of boot components
- BIOS provides the support for the configuration, enable/disable functions
- TPM is disabled by default

## 4.12.5 Power-Off Security

The PowerEdge T410 control panel is designed so that it is difficult for the power switch to be accidentally activated. In addition, there is a setting in the CMOS setup that disables the power button function.

## 4.12.6 Intrusion Alert

The PowerEdge T410 intrusion switch snaps into the ODD cage located on the top of the front fan (when viewed from the front and lay down the chassis and open the side cover). The switch detects when the side cover is opened.

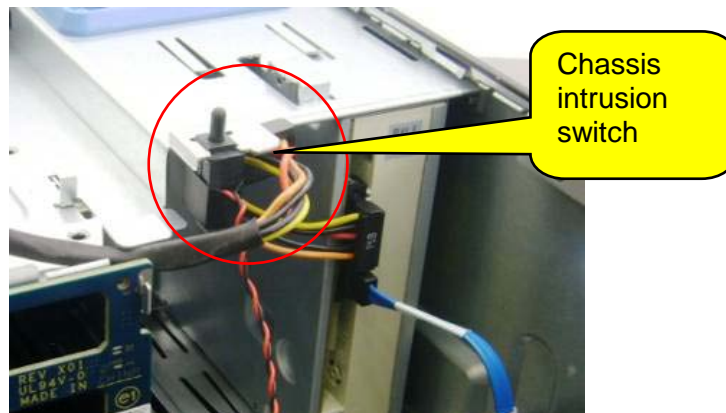

Figure 23. T410 Intrusion Switch

## 4.12.7 Secure Mode

The PowerEdge T410 BIOS can enter a secure boot mode via setup. This mode includes the option to lock out the power and NMI switches on the Control Panel or set up a system password. See the BIOS specification in the user's manual for more details.

## 4.13 USB Peripherals

The PowerEdge T410 has two internal USB connectors. Follow the Internal Persistent Storage Spec.



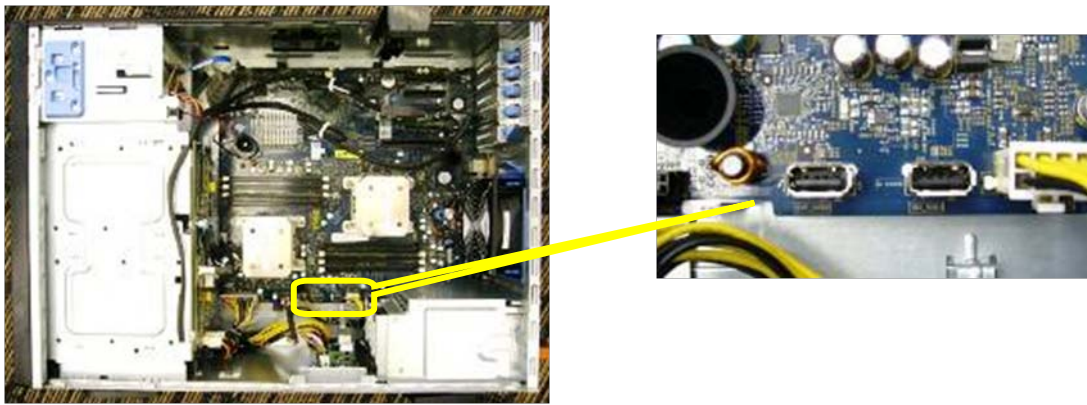

**Figure 24. T410 Internal USB Connectors**

## 4.14 Battery

The PowerEdge T410 provides a motherboard battery (model # CR2032). A battery holder for PERC cards on the T410 resides under the chassis top cover.



**Figure 25. T410 Motherboard Battery Placement**

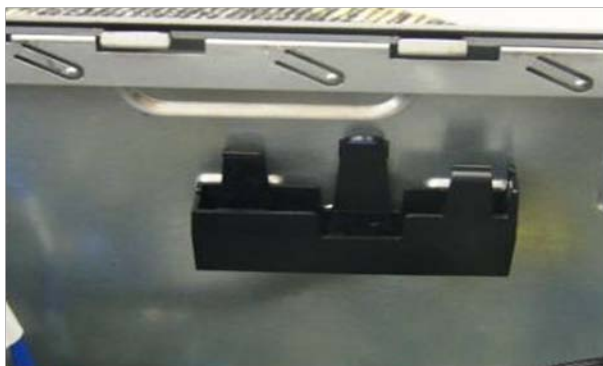

**Figure 26. PERC Battery Holder**

## 4.15 Field Replaceable Units (FRU)

The PowerEdge T410 planar contains a 16 K x 8 serial EEPROM to contain FRU information including Dell part number, part revision level, and serial number.

This T410 planar part is also used as SEL (system event log).

Parts available for field replacement:

- Backplane
- CMOS battery
- Expansion card
- Front bezel
- Hard Disk Drives
- I/O panel, Memory
- ODD
- PDB Power supply
- Processor
- Processor shroud
- System board
- System cover
- System fan.

## 5 Electrical

### 5.1 Volatility

The PowerEdge T410 contains volatile and non-volatile (NV) components. Volatile components lose their data immediately upon removal of power from the component. Non-volatile components continue to retain their data even after the power has been removed from the component. Components chosen as user-definable configuration options (those to the motherboard) are not included in the statement of volatility. Configuration option information (pertinent to options such as microprocessors, system memory, remote access controllers, and storage controllers) is available separately. The NV components present in the PowerEdge T410 server are discussed further in [Appendix A](#).

### 5.2 ePPID

The ePPID is an electronic repository for information from the PPID label stored in non-volatile RAM. BIOS reports the ePPID information using SMBIOS data structures, and the ePPID includes:

- Dell part number
- Part revision level
- Country of origin
- Supplier ID code
- Date code (date of manufacture)
- Unique sequence number

**Table 6. T410 ePPID Descriptions and Locations**

COMPONENT	DESCRIPTION	STORAGE LOCATION
Planar	PWA, PLN, SV, DELL, R410	iDRAC FRU
4" x 2.5" Backplane	PWA, BKPLN, SV, R410, 2.5SASX4	SEP
4" x 3.5" Backplane	PWA, BKPLN, SV, R410, 3.5SASX4	SEP
500W T410 Rdnt PSU	PWR SPLY,500W,RDNT, DELTA	PSU Microcontroller
	PWR SPLY,500W,RDNT,EMERSON	PSU Microcontroller
T410 PDB	ASSY,PWA,PDB,R410	Microcontroller
Storage Card	Description	Storage Location
PERC 6/I Adapter	ASSY, CRD, PERC6I-ADPT, SAS	FRU
PERC 6/E External	PWA, CTL, PCIE, SAS, PERC6/E,ADPT	FRU
SAS 6/iR integrated	PWA, CTL, SAS, SAS6/IR, INTG	FRU

## 6 Power, Thermal, and Acoustic

### 6.1 Power Supplies

The standard PowerEdge T410 tower server includes a single 525 W power supply. This power supply unit provides power to the T410 planar, the four internal hard drive bays, and the two 5.25" external drive bays. The T410's power is soft-switched, allowing power cycling via a switch on the front of the system enclosure or via a software control (through server management functions). This power system is compatible with industry standards, such as ACPI and Server 2000.

The T410 is powered by the standard non-redundant 525 W (Dell P/N C488 K) power supply or by two redundant 580 W (Dell P/N D888J) power supplies with PDB (power distribution board, Dell P/N M720J).

Figure 27 shows the 525W non-redundant PSU (Dell P/N C488 K), Figure 28 show the 580 W redundant PSU (Dell P/N D888J), Figure 29 shows the PDB (power distribution board, Dell P/N M720J).

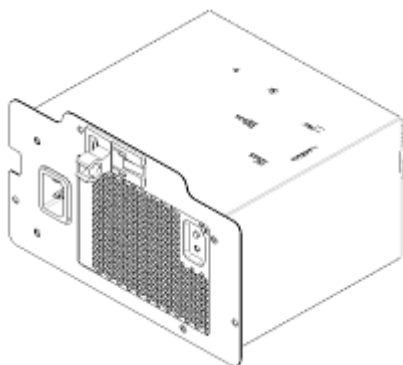

**Figure 27. Rear ISO View of Non-redundant PSU (Dell P/N C488 K)**

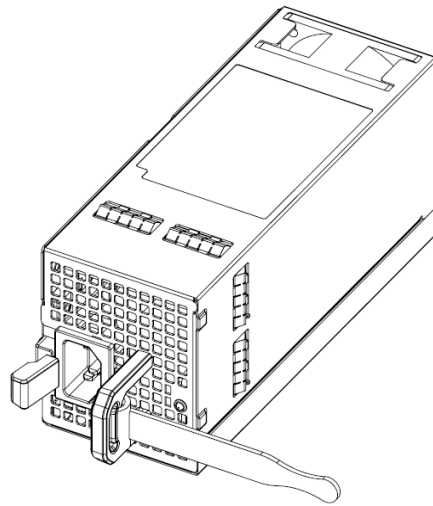

**Figure 28. Rear ISO View of Redundant PSU (Dell P/N D888J)**

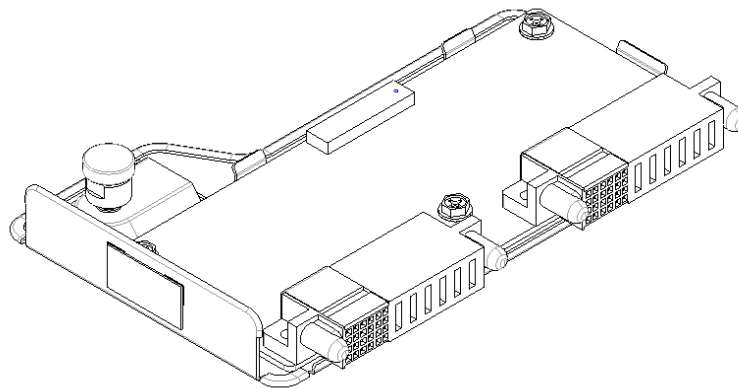

**Figure 29. Rear ISO View of PDB (Dell P/N M720J)**

## 6.2 Power Supply Specifications

The PowerEdge T410 power supplies have the following capacity:

There are two separate power supply connectors on the PowerEdge T410 planar: an ATX connector (2x12) and a 2x4 connector to provide an additional two pins for +12V. (The connector Pin definition is not ATX standard, it defined by power rating calculation.)

The 2x12 connector provides 3.3V, 5V, 12V and 5V standby to the system. The 3.3V standby to system is generated from 5V standby.

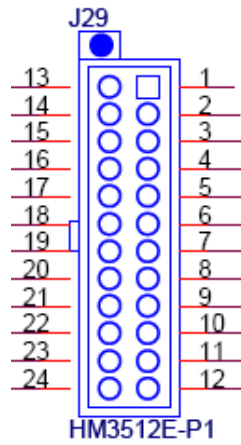

**Figure 30. Power Supply Connector (24 pins)**

**Table 7. Power Supply Connector (24 pins) Signals**

Pin	SIGNAL	Pin	SIGNAL
1	P5V	13	P3V3
2	P3V3	14	P3V3
3	P12VC	15	P12VC
4	P12VC	16	PS_ENABLE_CPLD_N
5	P12VE	17	P12VE
6	GND	18	GND
7	GND	19	GND
8	PS_PWROK	20	GND
9	SINGLE_PS_PRES_N	21	GND
10	GND	22	GND
11	GND	23	P12VD
12	P5V_AUX	24	P12VD

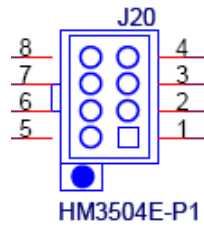

**Figure 31. Power Supply Connector (8 pins)**

**Table 8. Power Supply Connector (8 pins) Signals**

Pin	SIGNAL	Pin	SIGNAL
1	GND	5	P12VA
2	GND	6	P12VA
3	GND	7	P12VB
4	GND	8	P12VB

### 6.3 Environmental Specifications

Items additional to or exceptional from Dell’s Engineering Standard on Environmental Specification (#00109) are included in this section.

**Table 9. Operating/Non-operating Requirements**

		Operating Requirements	Non-Operating Requirements
<b>Temperature Ranges (For Altitude ≤900 m or 2952.75 ft)</b>		10 to 35 °C (50 to 95 °F)	-40 to 65 °C (-40 to 149 °F)
<b>Temperature Ranges (For Altitude &gt; 900 m or 2952.75 ft)</b>		10 to Note <sup>1</sup> °C (50 to Note <sup>2</sup> °F)	
<b>Temperature Gradient Maximum per 60 Min.</b>		10 °C	20 °C
<b>Humidity Percent Ranges Non-condensing</b>		20 to 80 % <sup>+</sup> (*Max Wet bulb temperature = 29 °C)	5 to 95 % <sup>+</sup> (*Max Wet bulb temperature = 38 °C)
<b>Humidity Gradient Maximum per 60 Min.</b>		10 %	10 %
<b>Altitude Ranges</b>	<b>Low Limits</b>	-50 feet (-15.2 meters)	-50 feet (-15.2 meters)
	<b>High Limits</b>	10,000 feet (3048 meters)	35,000 feet (10,668 meters)

Use the following formulas to calculate the maximum operating temperature (in °C) for a given altitude. Use the first formula if the altitude is stated in meters.

$$35 - \frac{\text{Maximum Altitude(in meters)} - 900}{300} \text{°C or } 35 - \frac{\text{Maximum Altitude(in ft)} - 2952.75}{984.25} \text{°C}$$

Use the following formulas to calculate the maximum operating temperature (in °F) for a given altitude. Use the first formula if the altitude is stated in meters and the second formula if the altitude is stated in feet.

$$95 - \left( \frac{[\text{Maximum Altitude}\{\text{in meters}\} - 900] \times 1.8}{300} \right) \text{°F or } 95 - \left( \frac{[\text{Maximum Altitude}\{\text{in ft}\} - 2952.75] \times 1.8}{984.25} + 32 \right) \text{°F}$$

## 6.4 Maximum Input Amps

The PowerEdge T410 power supply has automatic input voltage detection.

## 6.5 Energy Star Compliance

Energy Star is a late-add requirement to the platform and the specification has recently been defined. PSU meets the 80+ requirement as listed below.

**Table 10. Energy Star**

			Terms used in MRD		Terms Used Today	E-star requirement	
			Climate Savers	EPA	Server PSU (80+)	E-Star for Server	
2S	T410	Non-Redundant	N/A	EPA4.0	80+	TBD	525 W
		Redundant	Gold	N/A	80+Gold	TBD	580 W
	R410	Non-Redundant	N/A	EPA5.0	80+Bronze	TBD	480 W
		Redundant	Gold	N/A	80+Gold	TBD	500W
					PSU ONLY	System level certificate	

## 6.6 Acoustics

The PowerEdge T410 balances acoustic and thermal performance.

The PowerEdge T410 thermal solution uses a passive heat sink for the CPU and a rear 120X38mm fan exhausting air out of the system, which cools the PCI area and critical board components. The heat sink has a similar structure as the Miranda design, but it is designed with two heat embedded pipes (Dell PN F847J).

**Table 11. 410 Actual Test Results**

T410 Typical Configuration					
Mode	Loudness	Tonality (tu)	Prominent Ratio	Modulation	LwAd
Standby	0	0	None	28.99%	TBD
Idle	2.58 (avg) / 2.95(UL95)	0.12 (avg) / 0.21 (Max)	None	32% (Max.)	TBD
Stress	2.59 (avg) / 2.95 (UL95)	0.12 (avg) / 0.20 (Max)	None	32% (Max.)	TBD

## 7 Block Diagram

Figure 31 shows the PowerEdge T410 motherboard block diagram.

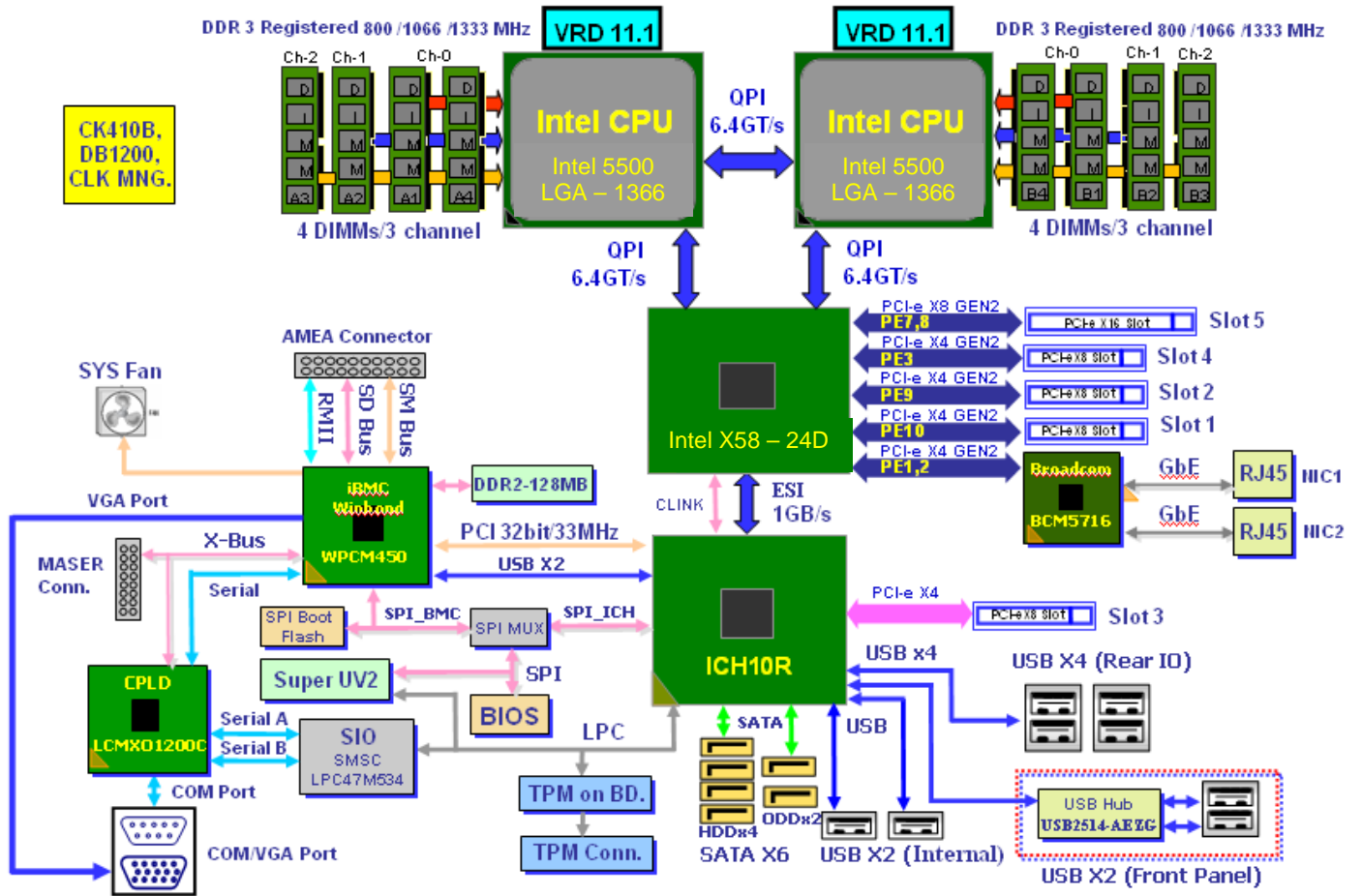

**Figure 32. T410 Motherboard Block Diagram**



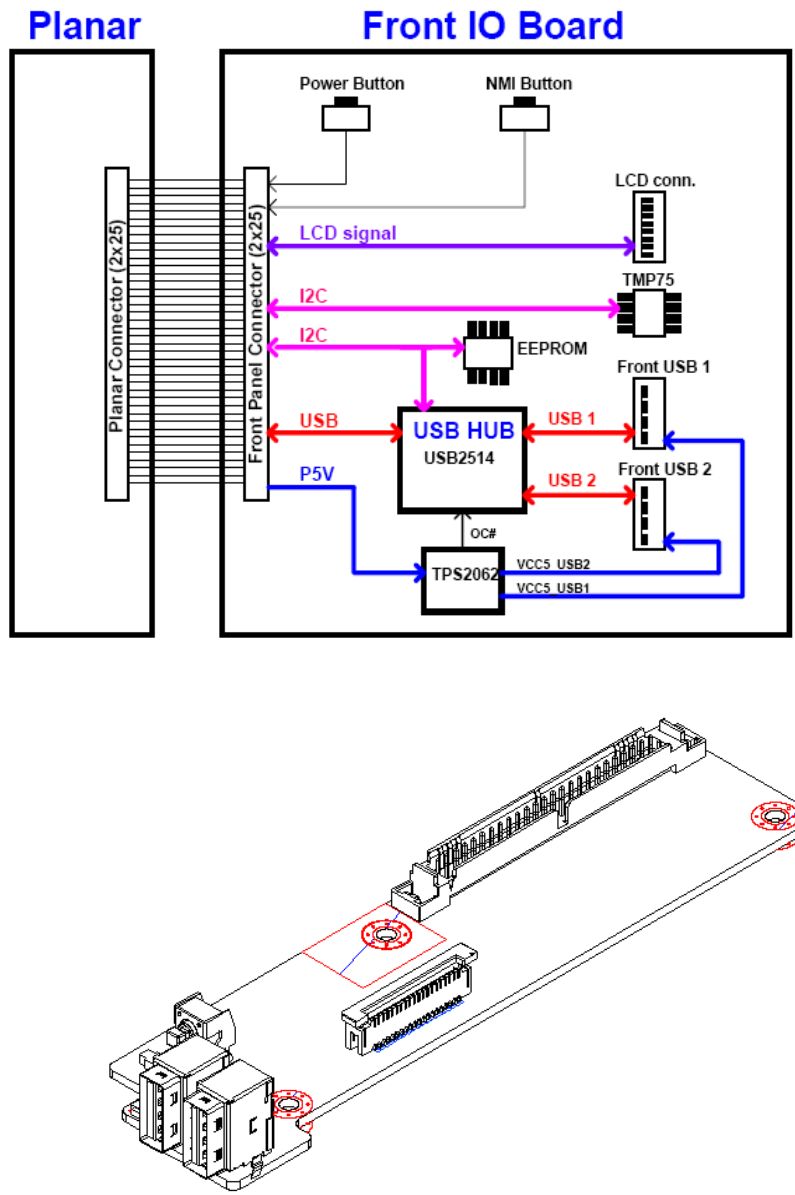

Figure 33. Front IO Board LCD Block Diagram and Top View

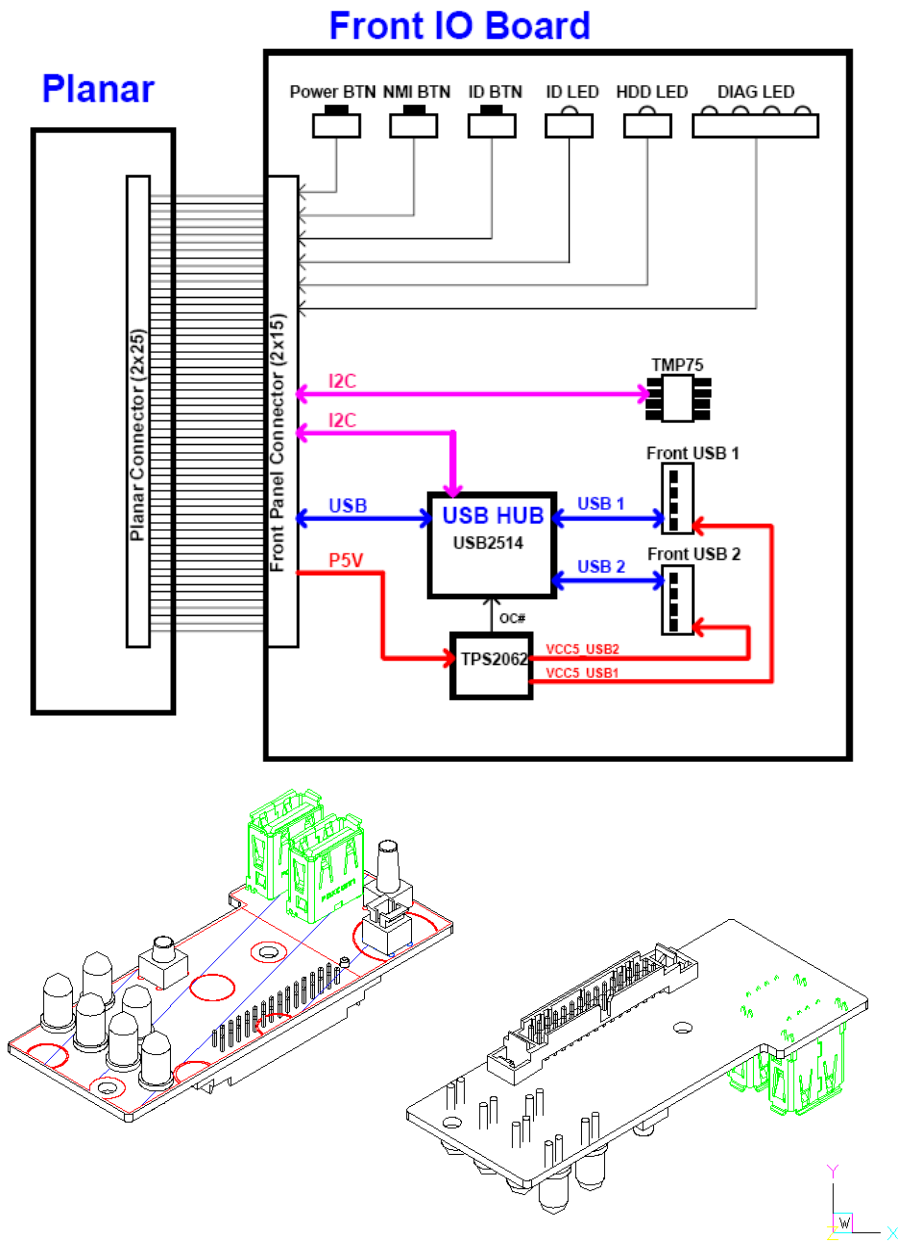

Figure 34. Front IO Board LED Block Diagram and Top/Bottom Views

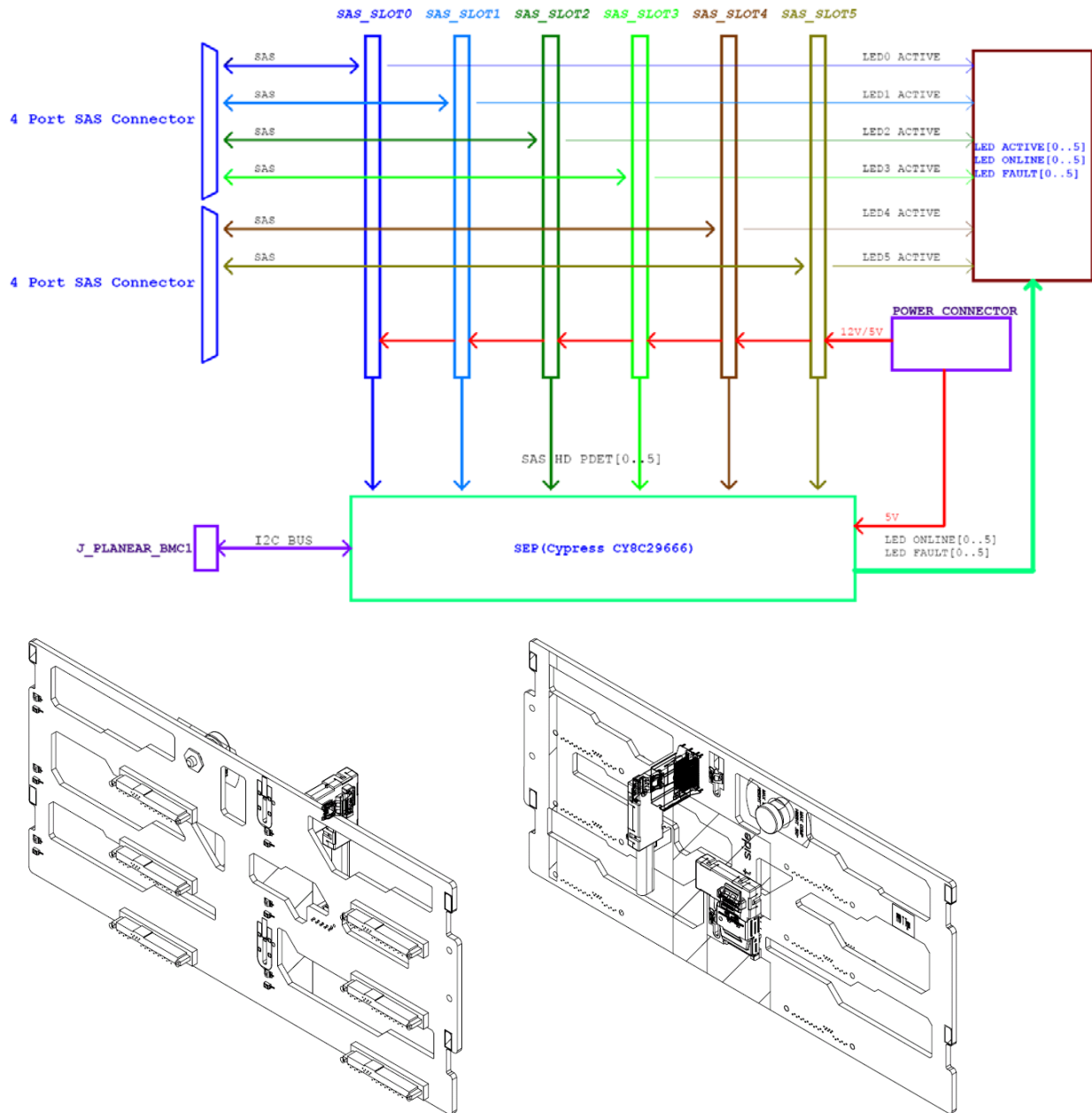

Figure 35. Hard Drive Backplane Board Block Diagram and Side Views

## 8 Processors

### 8.1 Overview

The PowerEdge T410 supports the Intel Xeon 5500 series processors originally released to the industry on March 30, 2009.

### 8.2 Supported Processors

Supported Intel Xeon 5500 series processors:

- X5560, 2.80GHz/8M,4C 95W
- E5540, 2.53GHz/8M,4C 80W

- E5530, 2.40GHz/8M,4C 80W
- L5520, 2.26GHz/8M,4C 60W
- L5506, 2.13GHz/4M,4C 60W
- E5520, 2.26GHz/8M,4C 80W
- E5506, 2.13GHz/4M,4C 80W
- E5504, 2.00GHz/4M,4C 80W
- E5502, 1.86GHz/4M,2C 80W

**Table 12. Supported Processor Descriptions and Features**

On-Line Processor Descriptions	Additional Features Not Included in Description	
<i>Intel Xeon X5560 2.80GHz, 8M cache, 6.4 GT/s QPI, Turbo, HT</i>	DDR3 Memory bus speed: up to 1333 MHz	95 W
<i>Intel Xeon E5540 2.53GHz, 8M cache, 5.86 GT/s QPI, Turbo, HT</i>	DDR3 Memory bus speed: up to 1066 MHz	80 W
<i>Intel Xeon E5530 2.40GHz, 8M cache, 5.86 GT/s QPI, Turbo, HT</i>	DDR3 Memory bus speed: up to 1066 MHz	80 W
<i>Intel Xeon E5520 2.26GHz, 8M cache, 5.86 GT/s QPI, Turbo, HT</i>	DDR3 Memory bus speed: up to 1066 MHz	80 W
<i>Intel Xeon L5520 2.26GHz, 8M cache, 5.86 GT/s QPI, Turbo, HT</i>	DDR3 Memory bus speed: up to 1066 MHz	60 W
<i>Intel Xeon E5506 2.13GHz, 4M cache, 4.8 GT/s QPI</i>	DDR3 Memory bus speed: 800MHz	80 W
<i>Intel Xeon L5506 2.13GHz, 4M cache, 4.8 GT/s QPI</i>	DDR3 Memory bus speed: 800MHz	60 W
<i>Intel Xeon E5504 2.00GHz, 4M cache, 4.8 GT/s QPI</i>	DDR3 Memory bus speed: 800MHz	80 W
<i>Intel Xeon E5502 1.86GHz, 4M cache, 4.8 GT/s QPI</i>	DDR3 Memory bus speed: 800MHz	80 W

- **QPI** = Quick Path Interconnect - is a point-to-point processor interconnect developed by Intel to compete with AMD's Hyper Transport; it is defined using GT/s = Gigatransfers per second referring to a number of data transfers or operations
- **Turbo**: Feature that increases the speed of the processor on demand (from OS) if the CPU is operating below power/thermal specifications
- **DDR-3 Memory bus speed**: 800MHz, 1066MHz or 1333MHz
- **HT**= Intel Hyper-threading technology

### 8.3 Processor Configurations

The PowerEdge T410 operates in single processor or dual processors. However, because the memory controller is embedded in the processor, when only one processor is installed in the system, it supports 4 DIMMs, min. 1 GB and max 32 GB. When two processors are installed in the system, it supports 8 DIMMs, min. 2 GB and max 64 GB.

## 8.4 Processor Installation

Please refer to the PowerEdge T410 owner's manual (downloadable from [www.support.dell.com](http://www.support.dell.com)) for information on processor installation. Memory

## 8.5 Overview/Description

The PowerEdge T410 uses DDR3 technology. In electronic engineering, DDR3 SDRAM or double-data-rate three synchronous dynamic random access memory is a random access memory interface technology used for high bandwidth storage of the working data of a computer or other digital electronic devices. DDR3 is part of the SDRAM family of technologies and is one of the many DRAM (dynamic random access memory) implementations.

The DDR3 primarily transfers twice the data rate of DDR2 (I/O at 8x the data rate of the memory cells it contains), thus enabling higher bus rates and higher peak rates than earlier memory technologies. In addition, the DDR3 standard allows for chip capacities of 512 megabits to 8 gigabits, effectively enabling a maximum memory module size of 16 gigabytes.

DDR3 memory on the PowerEdge T410 contains:

- 3 channels per processor
- Supports registered ECC DDR3 DIMMs or Un-buffered ECC DDR3 DIMMs.
- DDR3 speeds of 800/1066/1333 supported
- 8 (2/1/1) DIMM sockets (64 GB Maximum capacity)
- Single Rank, Dual Rank, and Quad Rank DIMMs supported

## 8.6 DIMM Types Supported

- 1 GB, DDR3 UDIMM, 1066 w/ECC
- 1 GB, DDR3 UDIMM, 1333 w/ECC
- 1 GB, DDR3 RDIMM, 1066 w/ECC
- 2 GB, DDR3 UDIMM, 1066 w/ECC
- 2 GB, DDR3 UDIMM, 1333 w/ECC
- 2 GB, DDR3 RDIMM, 1066 w/ECC
- 2 GB, DDR3 RDIMM, 1333 w/ECC
- 4 GB, DDR3 RDIMM, 1066 w/ECC
- 4 GB, DDR3 RDIMM, 1333 w/ECC
- 8 GB, DDR3 RDIMM, 1066 w/ECC

## 8.7 Slots/Risers

The PowerEdge T410 planar provides four 72-bit (240-pin) sockets for DIMM memory modules. These modules are DDR3-800/1066/1333 registered DDR SDRAM DIMMs. The modules are configured as 72-bits wide to provide for ECC. The memory controller in the CPU performs the ECC. The PowerEdge T410 planar supports a minimum of 1 GB upgradeable to 64 GB of RAM, using the following DIMM sizes:

- 1 GB, DIMM Module
- 2 GB, DIMM Module
- 4 GB, DIMM Module
- 8 GB, DIMM Module

Please refer to [Figure 36](#) for Dell factory supported memory configurations:

ONE PROCESSOR	Number of DIMM s	CPU A			
		DIMM Slots			
		Channel 0	Channel 1	Channel 2	
		A4	A1	A2	A3
1		X			
2		X	X		
3		X	X	X	X
4		X	X	X	X

TWO PROCESSORS	Number of DIMM s	CPU A				CPU B			
		DIMM Slots				DIMM Slots			
		Channel 0	Channel 1	Channel 2		Channel 0	Channel 1	Channel 2	
		A4	A1	A2	A3	B4	B1	B2	B3
2		X				X			
4		X	X			X	X		
6		X	X	X	X	X	X	X	X
8		X	X	X	X	X	X	X	X

Notes:

- \*Must have same DIMM type and DIMM speed
- \*Support mixed DIMM capacities in the system as field upgrades, but NOT out of Del Factory.

**Figure 36. DIMM Installation Specifications**

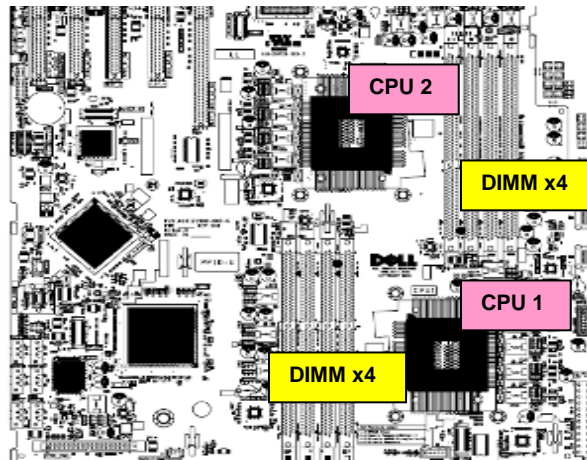

**Figure 37. DIMM Installation View**

## 8.8 Mirroring

In mirroring mode, the T410 must have identical memory configuration in Channel\_0 and Channel\_1 and not have memory in Channel\_3. When mirroring mode is enabled, usable memory capacity is half of the physical memory installed.

## 8.9 RAID

Please refer to previous section.

# 9 Chipset

## 9.1 Overview/Description

The PowerEdge T410 uses the Intel 5500 chipset 24 IOH Chipset (North Bridge).

Features include:

- Intel QuickPath interconnect: 2 ports
- ESI interface: x4 lanes
- Intel Virtualization Technology
- 24 PCIe Gen2 lanes

The Riser card (x16 slot + x8 slot → IOH PCIe x16 gen2 + IOH PCIe x4 gen2 ) features include:

- Integrated Intel Management Engine
- JTAG support

Also utilized is the Intel ICH10R Chipset (South Bridge)

Additionally there is the Integrated USB 2.0 (with 12 ports capability) used on the PowerEdge T410.

Features include:

- Two rear ports from ICH10R
- Two front ports and two internal port from USB Hub (1 port from ICH10R) on front panel board
- Integrated storage controllers
- SATA – six channels (via ICH10R)
- Max of one SATA drive (300 MB/s) Gen-2 on each channel

## 10 BIOS

### 10.1 Overview/Description

The PowerEdge R410 and the PowerEdge T410 BIOS is based on the Dell BIOS core and supports the following features:

- Intel 5500-EP Two-Socket Support
- Simultaneous Multi-Threading (SMT) support
- CPU Turbo Mode support
- PCI 2.3 compliant
- Plug n' Play 1.0a compliant
- MP (Multiprocessor) 1.4 compliant
- Boot from hard drive, optical drive, iSCSI drive, and USB key
- ACPI support
- Direct Media Interface (DMI) support
- PXE and WOL support for on-board NICs
- Memory mirroring support
- SETUP access through <F2> key at end of POST
- USB 2.0 (USB boot code is 1.1 compliant)
- F1/F2 error logging in CMOS
- Virtual KVM, CD, and floppy support (up-sell for MASER)
- Unified Server Configurator support
- Power management support including DBS, Power Inventory and multiple Power Profiles
- UEFI support

The R410/T410 BIOS does not support the following:

- Embedded Diagnostics (embedded in MASER)
- BIOS language localization
- BIOS recovery after bad flash (but can be recovered from iDRAC6 Express)

## 10.2 Supported ACPI States

The PowerEdge T410 processor supports the following C-States: C0, C1, C1E, C3, and C6. R410/T410 supports all of the available C-States.

The PowerEdge R410 and PowerEdge T410 support the available P-States as supported by the specific Intel 5500 processors.

**Table 13. Supported P-States**

Proc Number	QDF#	Frequency (GHz)	P-State	Turbo Mode Freq (Ghz)	Stepping
–	–	1.60	Pmin+0	–	–
–	–	1.73	Pmin+1	–	–
E5502	Q1G8	1.86	Pmin+2	N/A	D-0
E5504	Q1GM	2.00	Pmin+3	N/A	D-0
L5506	Q1HG	2.13	Pmin+4	N/A	D-0
E5506	Q1GL	2.13	Pmin+4	N/A	D-0
L5520	Q1GN	2.26	Pmin+5	4C/3C: 2.4 2C/1C: 2.53	D-0
E5520	Q1GR	2.26	Pmin+5	4C/3C: 2.4 2C/1C: 2.53	D-0
E5530	Q1GK	2.40	Pmin+6	4C/3C: 2.53 2C/1C: 2.66	D-0
E5540	Q1G2	2.53	Pmin+7	4C/3C: 2.66 2C/1C: 2.8	D-0
X5550	Q1GJ	2.66	Pmin+8	4C/3C: 2.93 2C/1C: 3.06	D-0
X5560	Q1GF	2.80	Pmin+9	4C/3C: 3.06 2C/1C: 3.20	D-0
X5570	Q1G9	2.93	Pmin+10	4C/3C: 3.20 2C/1C: 3.33	D-0

## 10.3 11G BIOS Power Management

The PowerEdge T410 Platform supports Performance/Power Page in the BIOS configuration GUI. These BIOS features are consolidated into a single page. The BIOS also provide user-friendly Power Profiles that adjust various BIOS settings.

Some of the power management settings can be grouped together. A group of a set of different parameters is called power profile. In total, the PowerEdge T410 BIOS setup provides five options: OS



Control, Active Power Controller, Static Max Performance, and Custom. OS Control mode is the default mode.

## 10.4 I<sup>2</sup>C (Inter-Integrated Circuit)

I<sup>2</sup>C is a simple bi-directional two-wire bus for efficient inter-integrated circuit control. All I<sup>2</sup>C -bus compatible devices incorporate an on-chip interface that allows them to communicate directly with each other via the I<sup>2</sup>C-bus. This solves the many interfacing problems encountered when designing digital control circuits. These I<sup>2</sup>C devices perform communication functions between intelligent control devices (e.g., microcontrollers), general-purpose circuits (e.g., LCD drivers, remote I/O ports, memories), and application-oriented circuits.

## 11 Embedded NICs/LAN on Motherboard (LOM)

### 11.1 Overview/Description

The BroadCom 5716 chip on the PowerEdge T410 motherboard is connected to the IOH via a PCI Express x4 gen2 link.

The 5716 chip provides a two-gigabit Ethernet port. There are two RJ-45 connectors with integrated magnetic on the rear of the system.

The firmware for the LOM chip resides in a flash part.

T410 supports Wake-On-LAN (WOL) from either port.

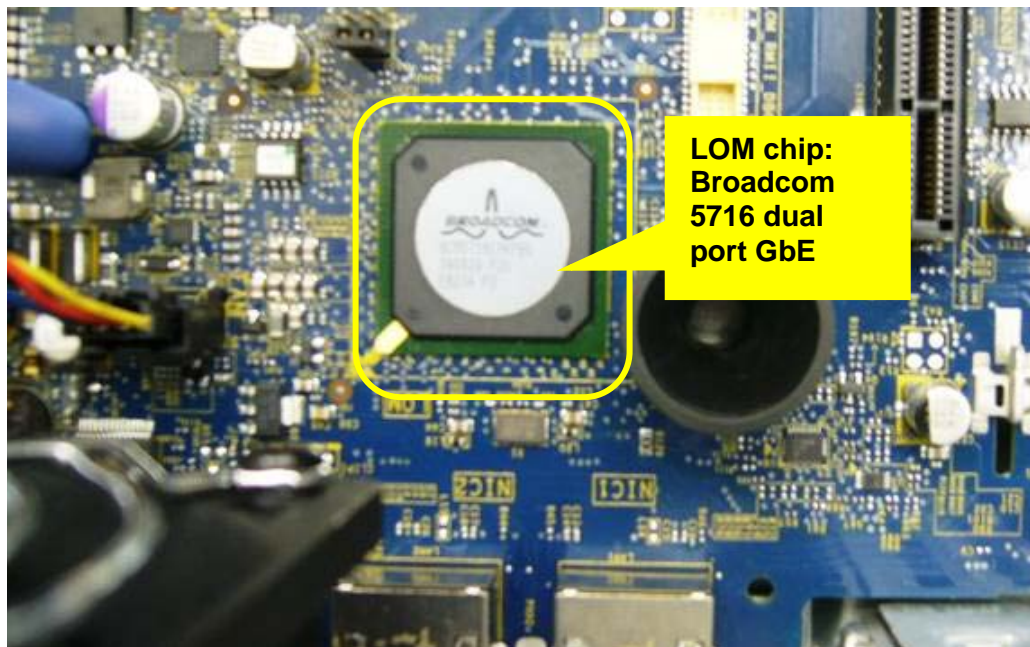

Figure 38. Broadcom 5716 Chip on T410 Motherboard

## 12 I/O Slots

### 12.1 Overview/Description

The PowerEdge T410 planar provides five PCI Express expansion slots and one dedicated slot:

- The PowerEdge T410 planar provides five PCI Express expansion slots
- One x16 PCIe Gen2 slots for full-height full-length cards, and connected to the IOH
- Three x8 PCIe Gen2 slot for full-height full-length cards, and connected to the IOH
- One x8 PCIe Gen1 slot for full-height full-length cards, and connected to the ICH
- System supports 25 W maximum power for all PCIe cards
- The PowerEdge T410 does not support hot-swapping of PCIe cards

**Table 14. T410 Slot Descriptions**

PCI Slot #	Mechanical	Electrical	Height	Length
1 (Gen2)	PCIe x8	PCIe x4	Full Height	Half Length
2 (Gen2)	PCIe x8	PCIe x4	Full Height	Full Length
3 (Gen1)	PCIe x8	PCIe x4	Full Height	Full Length
4 (Gen2)	PCIe x8	PCIe x4	Full Height	Half Length
5 (Gen2)	PCIe x16	PCIe x8	Full Height	Half Length

### 12.2 Quantities and Priorities

**Table 15. Descriptions of T410 Controllers**

Category	Description	Bandwidth	Max Quantity	Slot Priority
Internal Controller	PERC 6/i Adapter	x8	1	4
	SAS 6/iR	x8	2	4, 5
	SAS 5/iR	x4	2	4, 5
External Controllers	PERC 6/E 256	x8	2	5, 4
	PERC 6/E 512	x8	2	5, 4
	SAS 5/E	x8	2	4, 5
SCSI HBA	LSI2032 PCIe SCSI HBA (Sasquatch)	x4	2	4, 5

Category	Description	Bandwidth	Max Quantity	Slot Priority
1G NICs	Intel PRO/1000 PT Server Adapter	x1	4	2, 1, 3, 4
	Broadcom NetXtreme II 5709 Dual Port Ethernet PCIe Card with TOE	x4	4	2, 1, 3, 4
	Broadcom NetXtreme II 5709 Dual Port Ethernet PCIe Card with TOE and iSCSI Offload	x4	4	2, 1, 3, 4
	Intel Gigabit VT Quad Port Server Adapter	x4	4	2, 1, 3, 4

## 12.3 Boot Order

PCI Express Lane Assignments and Scan Order in T410:

- IOH port 1, 2 (PCI Express Gen2 x4) – Broadcom BCM5716 Gigabit LOM
- IOH port 3 (PCI Express Gen2 x4) – Slot 4
- IOH port 7/8 (PCI Express Gen2 x8) – Slot 5
- IOH port 9 (PCI Express Gen2 x4) – Slot 2
- IOH port 10 (PCI Express Gen2 x4) – Slot 1
- ICH10R port1-4 (PCI Express Gen1 x4) – Slot 3

## 13 Storage

### 13.1 Overview/Description

The PowerEdge T410 supports up to six hard disk drives.

- 4x 3.5" cabled SATA from motherboard SATA connector
- 6x 3.5" cabled SAS or SATA via add-on storage controller
- 6x 3.5" hot-swap SAS or SATA via add-on storage controller
- 6x 2.5" hot-swap SAS or SATA or SSD via add-on storage controller

The 2.5" Hard Disk Drives requires hot-swap configuration with the 3.5" Hot Plug HDD Carrier tray and the retention kit.

Customer must decide for cabled configuration or hot-swap configuration at point of purchase. This is not an upgrade option for APOS.



Figure 39. Hot Swap and Cabled Hard Drives

## 13.2 Drives

Refer to [Section 3.2 “Product Features Summary”](#) for supported type and capacities.

## 13.3 RAID Configurations

Table 16. NO HDD and Cabled HDD Configurations

Cabled/Hot Swap	Configuration Type	Configurations		Description	Min HDD	Max HDD	MOD
Cabled	No HDD	C0A	NCZCBL	No HDD, Cabled HDD Chassis	0	0	X343M
Hot-Swap	No HDD	C0B	NCZ	No HDD, Hot-Swap HDD Chassis	0	0	X398M
Cabled	Embedded SATA	C1	MSTCBL	On-board SATA Controller (ICH10R)	1	4	C490N
Cabled	SAS/SATA – NO RAID	C2	ASSCBL	Add-in SAS/SATA RAID card, No RAID (SAS 6/iR)	1	6	Y322M
Cabled	SAS/SATA – RAID0	C3	ASSR0CBL	Add-in SAS/SATA RAID card, RAID 0 (SAS 6/iR or PERC 6/i)	1	6	W968M

Cabled/Hot Swap	Configuration Type	Configurations		Description	Min HDD	Max HDD	MOD
Cabled	SAS/SATA – RAID1	C4	ASSR1CBL	Add-in SAS/SATA RAID card, RAID 1 (SAS 6/iR or PERC 6/i)	2	2	C494N
Cabled	SAS/SATA – RAID5	C5	ASSR5CBL	Add-in SAS/SATA RAID card, RAID 5 (PERC 6/i)	3	6	D131N
Cabled	SAS/SATA – RAID6	C6	ASSR6CBL	Add-in SAS/SATA RAID card, RAID 6 (PERC 6/i)	4	6	Y323M

**Table 17. Hot-Swap HDD Configurations**

Cabled/Hot Swap	Configuration Type	Configurations		Description	Min HDD	Max HDD	MOD
Hot-Swap	SAS/SATA /SSD– NO RAID	C7	ASS	Add-in SAS/SATA RAID card, No RAID (SAS 6/iR)	1	6	W969M
Hot-Swap	SAS/SATA /SSD– RAID0	C8	ASSR0	Add-in SAS/SATA RAID card, RAID 0 (SAS 6/iR or PERC 6/i)	1	6	Y324M
Hot-Swap	SAS/SATA /SSD– RAID1	C9	ASSR1	Add-in SAS/SATA RAID card, RAID 1 (SAS 6/iR or PERC 6/i)	2	2	D132N
Hot-Swap	SAS/SATA /SSD– RAID5	C10	ASSR5	Add-in SAS/SATA RAID card, RAID 5 (PERC 6/i)	3	6	C495N
Hot-Swap	SAS/SATA /SSD– RAID6	C11	ASSR6	Add-in SAS/SATA RAID card, RAID 6 (PERC 6/i)	4	6	X399M
Hot-Swap	SAS/SATA /SSD– RAID10	C12	ASSR10	Add-in SAS/SATA RAID card, RAID 10 (PERC 6/i)	4	6	X400M
Hot-Swap	SAS/SATA /SSD– RAID1+ RAID1	C13	ASSR1R1	Add-in SAS/SATA RAID card, RAID 1 + RAID 1 (SAS 6/iR or PERC 6/i)	2+2	2+2	D134N

Cabled/Hot Swap	Configuration Type	Configurations		Description	Min HDD	Max HDD	MOD
Hot-Swap	SAS/SATA /SSD– RAID1+ RAID5	C14	ASSR1R5	Add-in SAS/SATA RAID card, RAID 1 + RAID5 (PERC 6/i)	2+3	2+4	C496N

**Table 18. Mix HDD Configurations**

Cabled/Hot Swap	Configuration Type	Configurations		Description	Min HDD	Max HDD	MOD
Hot-Swap	Mix SAS and SATA – No RAID	C15	ASS-X	Add-in SAS/SATA RAID card, No RAID (SAS 6/iR)	2xSAS + 1xSATA	2xSAS + 4xSATA	Y327M
Hot-Swap	Mix SAS and SATA – RAID1 + RAID1	C16	ASSR1R 1-X	Add-in SAS/SATA RAID card, RAID 1 + RAID 1 (SAS 6/iR or PERC 6/i)	2xSAS + 2xSATA	2xSAS + 2xSATA	W970 M
Hot-Swap	Mix SAS and SATA – RAID1 + RAID5	C17	ASSR1R 5-X	Add-in SAS/SATA RAID card, RAID 1 + RAID 5 (PERC 6/i)	2xSAS + 3xSATA	2xSAS + 4xSATA	C501N

## 13.4 Storage Controllers

Refer to [Section 3.2 “Product Features Summary”](#) and [Section 13.2 “Quantities and Priorities”](#).

## 13.5 LED Indicators

Refer to [Section 4.3 “Front Panel View and Features”](#).

## 13.6 Optical Drives

T410 supports up to two SATA interfaces, DVD-ROM or DVD+/-RW.

Refer to [Section 3.2 “Product Features Summary”](#).

## 13.7 Tape Drives

T410 supports internal and external backup device.

Refer to [Section 3.2 “Product Features Summary”](#) for the supported devices.

## 14 Video

### 14.1 Overview/Description

The embedded video on PowerEdge T410 is based on the Matrox G200eW with 16 MB memory integrated in the Windbond WPCM450 Base Management Controller (BMC). This device only supports 2D graphics.

The PowerEdge T410 system supports the following 2D graphics video modes:

- 1280x1024@85Hz for KVM and 1600x1200@60Hz for video out
- 640x480 (60/72/75/85 Hz; 8/16/32-bit color)
- 800x600 (60/72/75/85 Hz; 8/16/32-bit color)
- 1024x768 (60/72/75/85 Hz; 8/16/32-bit color)
- 1152x864 (75 Hz; 8/16/32-bit color)
- 1280x1024 (60/75/85 Hz; 8/16-bit color)
- 1280x1024 (60 Hz, 32-bit color) (note 32 bit color is only supported at 60 Hz for this resolution)

## 15 Audio

### 15.1 Overview/Description

Not available for server.

## 16 Rack Information

T410 is not rackable.

T410 can be placed in the rack enclosure via the third-party tray.

## 17 Operating Systems

**Table 19. Microsoft OS<sup>1</sup>**

Operating Systems	x86 or x64	Install	Factory Install	Logo/Certification	Test/Validate	Support	Engineering Response	
Small Business Server 2008	X64	Standard	FI	Covered in Server 2008 family	Yes	Yes	Yes	
		Premium						
Small Business Server 2003 R2	32-bit x86	Standard	FI (SP2 only)	Covered in Server 2003 family	Yes	Yes	-	
		Premium	DIB (SP2 only)					
Windows Server 2008 <sup>2</sup>	x32-bit x86	Enterprise	FI	WHQL	Yes	Yes	Logo Certification requires tests to be performed on Enterprise edition of Windows Server 2008 with the latest service pack supported.	
	x64	Standard		N/A				
		Enterprise		WHQL	Yes	Yes		
		Datacenter		N/A				
Windows Server 2003	32-bit x86	Standard	N/A	N/A	Yes	Yes	Windows Server 2003 can be removed for all SKUs except Web edition. Support is only for Windows Server 2003 R2 and Windows Server 2008	
		Enterprise						
	x64	Standard		N/A	N/A	Yes		Yes
		Enterprise						

Operating Systems	x86 or x64	Install	Factory Install	Logo/Certification	Test/Validate	Support	Engineering Response
Windows Server 2003 R2	32-bit x86	Standard	FI (SP2 only)	N/A	Yes	Yes	Logo Certification requires tests to be performed on Enterprise edition of Windows Server 2003 R2 with the latest service pack supported.
		Enterprise		WHQL			
	x64	Standard	FI (SP2 only)	N/A	Yes	Yes	
		Enterprise		WHQL			
		Datacenter	DIB (SP2 only)	N/A			
Windows Essential Business Server (Centro)	X64	Standard	DIB	Covered in Server 2008 family	Yes	Yes	-
		Premium					

1. Schedule for all servers is RTS.
2. Windows Server 2008 SP2 and R2 is POST-RTS supported.

**Table 20. Linux OS**

Operating Systems	Installation	Factory Install	Logo/Certification	Schedule
Red Hat Enterprise Linux 4.7	Enterprise Server (ES) x86-64	DIB, NFI	Yes	POST_RTS (CY09 Q2 block)
	Advance Server (AS) x86-64			POST_RTS (CY09 Q2 block)
	Enterprise Server (ES) x86-32	DIB, NFI	Yes	POST_RTS (CY09 Q2 block)
	Advance Server (AS) x86-32			POST_RTS (CY09 Q2 block)
Red Hat Enterprise Linux 5.2	Standard (2-sckt) x86-64 Advance Platform (4-sckt) x86-64 Standard (2-sckt) x86-32 Advance Platform (4-sckt) x86-32	FI DIB, NFI	Yes	RTS
SLES10 SP2	x86-64	DIB, NFI	Yes	RTS
SLES 11	x86-64	FI	Yes	POST-RTS (CY09 Q2 block)



## 18 Virtualization

### 18.1 Overview/Description

**Table 21. Supported Virtualization OS**

Virtualization OS	Installation	R410	T410
VMWare vSphere version 4.0 - Classic	DIB	Q2 block w/4.0	Q2 block w/4.0
VMWare vSphere version 4.0 - Embedded (HDD installable)	Download from VMWare.com	Q2 block w/4.0	Q2 block w/4.0
VMware Virtual Infrastructure 3 ESX/ESXi 3.5 Update 4 - Classic	DIB	RTS w/U4	RTS w/U4
VMware Virtual Infrastructure 3 ESX/ESXi 3.5 Update 4 - Embedded (HDD installable)	Download from VMWare.com	RTS w/U4	RTS w/U4
Citrix XenServer Enterprise 4.X	Download from Citrix	N/A (Offer through Citrix)	N/A (Offer through Citrix)
Citrix XenServer Enterprise 4.X (embedded)	Download from Citrix	N/A (Offer through Citrix)	N/A (Offer through Citrix)
Hyper-V (Microsoft Hyper-V server 2008 R2) <formally known as VSKU>	Freely downloadable	Download version	Download version
Hyper-V Role <refer to OS support matrix>	loaded on top of FI WS2008	FI	FI
Embedded Hypervisor	--	No	No

#### Note

T410 and R410 do not support Hypervisor (through the internal persistent storage via SD card). An embedded version of virtualization OS is supported by installed hard drives.

## 19 Systems Management

### 19.1 Overview/Description

Dell aims on delivering open, flexible, and integrated solutions that help you reduce the complexity of managing disparate IT assets by building comprehensive IT management solutions. Combining Dell PowerEdge Servers with a wide selection of Dell-developed management solutions gives you choice and flexibility, so you can simplify and save in environments of any size. To help you meet your server performance demands, Dell offers Dell OpenManage™ systems management solutions for:

- Deployment of one or many servers from a single console
- Monitoring of server and storage health and maintenance
- Update of system, operating system, and application software

Dell offers IT management solutions for organizations of all sizes – priced, sized, and supported right.

## 19.2 Server Management

A Dell Systems Management and Documentation DVD and a Dell Management Console DVD are included with the product. ISO images are also available. A brief description of available content:

- **Dell Systems Build and Update Utility:** Dell Systems Build and Update Utility assists in OS install and pre-OS hardware configuration and updates.
- **OpenManage Server Administrator:** The OpenManage Server Administrator (OMSA) tool provides a comprehensive, one-to-one systems management solution, designed for system administrators to manage systems locally and remotely on a network. OMSA allows system administrators to focus on managing their entire network by providing comprehensive one-to-one systems management.
- **Management Console:** Our legacy IT Assistant console is also included, as well as tools to allow access to our remote management products. These tools are Remote Access Service, for iDRAC, and the BMC Management Utility.
- **Active Directory Snap-in Utility:** The Active Directory Snap-in Utility provides an extension snap-in to the Microsoft Active Directory. This allows you to manage Dell specific Active Directory objects. The Dell-specific schema class definitions and their installation are also included on the DVD.
- **Dell Systems Service Diagnostics Tools:** Dell Systems Service and Diagnostics tools deliver the latest Dell optimized drivers, utilities, and operating system-based diagnostics that you can use to update your system.
- **eDocs:** The section includes Acrobat files for PowerEdge systems, storage peripheral, and OpenManage software.
- **Dell Management Console DVD:** The Dell Management Console is a Web-based systems management software that enables you to discover and inventory devices on your network. It also provides advanced functions, such as health and performance monitoring of networked devices and patch management capabilities for Dell systems.
- **Server Update Utility:** In addition to the Systems Management Tools and Documentation and Dell Management Console DVDs, customers have the option to obtain Server Update Utility DVD. This DVD has an inventory tool for managing updates to firmware, BIOS and drivers for either Linux or Windows varieties.

## 19.3 Embedded Server Management

The PowerEdge T410 implements circuitry for the next generation of Embedded Server Management. It is Intelligent Platform Management Interface (IPMI) v2.0 compliant. The optional iDRAC (Integrated Dell Remote Access Controller) is responsible for acting as an interface between the host system and its management software and the periphery devices. These periphery devices consist of the PSUs, the storage backplane, integrated SAS HBA or PERC 6/I, and control panel with display.

The optional upgrade to iDRAC6 provides features for managing the server remotely or in data center lights-out environments.

Advanced iDRAC features require the installation of the optional iDRAC6 Enterprise card.

## 19.4 Lifecycle Controller and Unified Server Configurator

Embedded management is comprised of several interdependent pieces:

- Lifecycle Controller
- Unified Server Configurator

- iDRAC6
- vFlash

Lifecycle controller powers the embedded management features. It is integrated and tamperproof storage for system-management tools and enablement utilities (firmware, drivers, etc.). It is flash partitioned to support multiple, future-use cases.

Dell Unified Server Configurator (USC) is a local 1:1 graphical user interface embedded on Lifecycle Controller that aids in local server provisioning in a pre-OS environment. For servers with iDRAC Express, the Lifecycle Controller offers OS install, platform updates, platform configuration, and diagnostics capabilities. For servers without iDRAC Express, this utility has limited functionality and offers OS install and diagnostics capabilities only.

To access the Unified Server Configurator, press the <F10> key within 10 seconds of the Dell logo’s appearance during the system boot process. Current functionality enabled by the Unified Server Configurator includes:

**Table 22. Unified Server Configurator Features and Description**

Feature	Description
Faster O/S Installation	Drivers and the installation utility are embedded on system, so no need to scour DELL.COM
Faster System Updates	Integration with Dell support automatically directed to latest versions of the Unified Server Configurator, iDRAC, RAID, BIOS, NIC, and Power Supply
Update Rollback	Ability to recover to previous “known good state” for all updatable components
More Comprehensive Diagnostics	Diagnostic utilities are embedded on system
Simplified Hardware Configuration	Detects RAID controller and allows user to configure virtual disk and choose virtual disk as boot device, eliminating the need to launch a separate utility. Also provides configuration for iDRAC, BIOS, and NIC/LOM.

## 19.5 iDRAC Express

The optional iDRAC Express is the first tier of iDRAC6 upgrades. In addition to upgrading the system with a Lifecycle Controller, the iDRAC6 Express offers the following key features:

- Graphical web interface
- Standard-based interfaces
- Server Sensor monitoring and fault alerting
- Secure operation of remote access functions including authentication, authorization, and encryption
- Power control and management with the ability to limit server power consumption and remotely control server power states
- Advanced troubleshooting capabilities

For more information on iDRAC6 Express features see table below.

## 19.6 iDRAC6 Enterprise

The optional iDRAC6 Enterprise card provides access to advanced iDRAC6 features. The iDRAC6 Enterprise connects directly to the T410 planar and is mounted parallel to the planar with stand-offs.

Key features for the iDRAC6 Enterprise include:

- Scripting capability with Dell's Racadm command-line
- Remote video, keyboard, and mouse control with Virtual Console
- Remote media access with Virtual Media
- Dedicated network interface

Additionally, the iDRAC6 Enterprise can be upgraded by adding the vFlash Media card. This is a 1 GB Dell branded SD card that enables a persistent 256 MB virtual flash partition. In the future, vFlash will be expanded to include additional features.

A more detailed feature list for iDRAC6 Enterprise and vFlash is included in [Table 23](#).

**Table 23. Features List for BMC, iDrac, and vFlash**

Feature	BMC	iDRAC 6 Express	iDRAC6 Enterprise	vFlash Media
<b>Interface and Standards Support</b>				
IPMI 2.0	✓	✓	✓	✓
Web-based GUI		✓	✓	✓
SNMP		✓	✓	✓
WSMAN		✓	✓	✓
SMASH-CLP		✓	✓	✓
Racadm command-line			✓	✓
<b>Conductivity</b>				
Shared/Failover Network Modes	✓	✓	✓	✓
IPv4	✓	✓	✓	✓
VLAN Tagging	✓	✓	✓	✓
IPv6		✓	✓	✓
Dynamic DNS		✓	✓	✓
Dedicated NIC			✓	✓
<b>Security and Authentication</b>				
Role-based Authority	✓	✓	✓	✓
Local Users	✓	✓	✓	✓
Active Directory		✓	✓	✓
SSL Encryption		✓	✓	✓
<b>Remote Management and Remediation</b>				
Remote Firmware Update	✓	✓	✓	✓
Server power control	✓	✓	✓	✓
Serial-over-LAN (with proxy)	✓	✓	✓	✓

Feature	BMC	iDRAC 6 Express	iDRAC6 Enterprise	vFlash Media
Serial-over-LAN (no proxy)		✓	✓	✓
Power capping		✓	✓	✓
Last crash screen capture		✓	✓	✓
Boot capture		✓	✓	✓
Serial-over-LAN		✓	✓	✓
Virtual media			✓	✓
Virtual console			✓	✓
Virtual console sharing			✓	✓
Virtual flash				✓
<b>Monitoring</b>				
Sensor Monitoring and Alerting	✓	✓	✓	✓
Real-time Power Monitoring		✓	✓	✓
Real-time Power Graphing		✓	✓	✓
Historical Power Counters		✓	✓	✓
<b>Logging Features</b>				
System Event Log	✓	✓	✓	✓
RAC Log		✓	✓	✓
Trace Log			✓	✓

## 20 Peripherals

### 20.1 USB Peripherals

- Optional USB 1.44 MB floppy drive
- Optional USB DVD-ROM

### 20.2 External Storage

Refer to [Section 3.2 “Product Features Summary”](#).

## 21 Packaging Options

Single pack only.

## Appendix A. T410 Volatility Chart

**Table 24. T410 Volatility Chart**

<b>Server BIOS Memory</b>	
Size	32 Mbit
Type	Flash EEPROM
Can user programs or operating system write data to it during normal operation?	No
Purpose	Boot Code and Configuration Information
How is data input to this memory?	Loading flash memory requires a vendor provided firmware file and loader program executed by booting up the system from a floppy or OS based executable containing the firmware file and the loader. System loaded with arbitrary data in firmware memory would not operate.
How is this memory write protected?	Software write protected
<b>Server CMOS (Complementary Metal-Oxide Semiconductor) Memory</b>	
Size	512 Bytes
Type	Battery backed NVRAM
Can user programs or operating system write data to it during normal operation?	No
Purpose	RTC and configuration settings
How is data input to this memory?	F2 Setup Menu during POST
How is this memory write protected?	N/A
Remarks	Jumper on motherboard can be used to clear to factory default settings
<b>LOM (LAN [Network Interface] on Motherboard) Memory</b>	
Size:	4Mb (1MB)
Type	Flash
Can user programs or operating system write data to it during normal operation?	Yes, under software control.
Purpose	Contains LOM boot code and configuration data
How is data input to this memory?	Requires vendor provided firmware file and loader program used during factory assembly or possible field update. A system loaded with arbitrary data in firmware memory would not operate.
How is this memory write protected?	Software control.

<b>Server System Event Log Memory / FRU</b>	
Size	16 KB
Type	EEPROM
Can user programs or operating system write data to it during normal operation?	No
Purpose	Store System Events
How is data input to this memory?	BMC controller write
How is this memory write protected?	Not write protected
<b>Power Supply FRU</b>	
Size	256 Bytes
Type	EEPROM
Can user programs or operating system write data to it during normal operation?	No
Purpose	Store power supply information
How is data input to this memory?	Programmed by the power supply manufacturer.
How is this memory write protected?	Not write protected
<b>TPM (Trusted Platform Module; For boards shipped outside of China; Boards sold to destinations in China do not have TPM at this time)</b>	
Size	Unspecified size of user ROM, RAM, EEPROM; 128 bytes of OTP memory included
Type	ROM, RAM, EEPROM
Can user programs or operating system write data to it during normal operation?	Yes, OSes and applications that conform to the TCG standard can write data to the TPM during normal operation. Access to the NV Storage is controlled by the TPM owner.
Purpose	Trusted Platform Module NV storage. May be used to securely storage of encryption keys.
How is data input to this memory?	TCG TPM Specification defined command interface or Using TPM Enabled operating systems
How is this memory write protected?	As defined by the TCG TPM Specification, protection of this NV memory area is configurable by the TPM owner.

<b>Backplane Firmware and FRU</b>	
Size	32 KB
Type	Flash
Can user programs or operating system write data to it during normal operation?	No
Purpose	Backplane Firmware and FRU data storage
How is data input to this memory?	Loading flash memory requires a vendor provided firmware file and loader program which is executed by booting up the system from a floppy or OS based executable containing the firmware file and the loader. System loaded with arbitrary data in firmware memory would not operate.
<b>Embedded Bootable Memory Device</b>	
Size	1 GB
Type	SD card
Can user programs or operating system write data to it during normal operation?	Yes
Purpose	Optional embedded boot device
How is data input to this memory?	Factory installed or via USB bus.
How is this memory write protected?	Not write protected
<b>Server BMC (Baseboard Management Controller) Firmware Flash Memory</b>	
Size	16 MB Flash
Type	SPI Flash
Can user programs or operating system write data to it during normal operation?	No
Purpose	Stores the BMC Firmware
How is data input to this memory?	Loading flash memory requires a vendor provided firmware file and loader program executed by booting up the system from a floppy or OS based executable containing the firmware file and the loader. System loaded with arbitrary data in firmware memory would not operate.
How is this memory write protected?	Software write protected