

# PowerEdge R415



## Technical Guide



The PowerEdge R415 offers enterprise-class features with a balance of processing power and value.

---

This document is for informational purposes only. Dell reserves the right to make changes without further notice to any products herein. The content provided is as is and without express or implied warranties of any kind.

Dell, PowerEdge, OpenManage, and ReadyRails are trademarks of Dell, Inc. AMD, AMD Opteron, AMD PowerNow!, CoolCore, and combinations thereof are trademarks of Advanced Micro Devices, Inc. Citrix® and XenServer™ are trademarks of Citrix Systems, Inc. and/or one or more of its subsidiaries, and may be registered in the United States Patent and Trademark Office and in other countries. Intel and Xeon are registered trademarks of Intel Corporation in the U.S. and other countries. Broadcom is a registered trademark of Broadcom Corporation and/or its affiliates in the United States, certain other countries and/or the EU. Matrox is a registered trademark of Matrox Electronic Systems Ltd. Microsoft, Windows, Windows Server, SQL Server, BitLocker, and Hyper-V are either registered trademarks or trademarks of Microsoft Corporation in the United States and/or other countries. Nuvoton is a registered trademark of Nuvoton Technology Corporation. Red Hat is a registered trademark of Red Hat, Inc. in the United States and other countries. Linux is a registered trademark of Linus Torvalds. QLogic is a registered trademark of Qlogic Corporation. VMware and ESX are registered trademarks and vSphere and ESXi are trademarks of VMware, Inc. in the United States and/or other jurisdictions. Other trademarks and trade names may be used in this document to refer to either the entities claiming the marks and names or their products. Dell disclaims proprietary interest in the marks and names of others.

©Copyright 2010 Dell Inc. All rights reserved. Reproduction or translation of any part of this work beyond that permitted by U.S. copyright laws without the written permission of Dell Inc. is unlawful and strictly forbidden.

November 2010

# Table of Contents

|        |   |    |
|--------|---|----|
| 1      | Product Comparison.....                               | 7  |
| 1.1    | Overview.....   | 7  |
| 1.1.1  | Designed to Go the Distance.....                      | 7  |
| 1.1.2  | Efficient from the Inside Out.....                    | 7  |
| 1.1.3  | Easy to Manage.....                                   | 7  |
| 1.2    | Comparison.....                                       | 8  |
| 2      | System Overview.....                                  | 11 |
| 3      | Mechanical.....                                       | 14 |
| 3.1    | Chassis Description.....                              | 14 |
| 3.2    | Dimensions and Weight.....                            | 14 |
| 3.3    | Front Panel View and Features.....                    | 15 |
| 3.4    | Back Panel View and Features.....                     | 15 |
| 3.5    | Power Supply Indicators.....                          | 16 |
| 3.6    | NIC Indicators.....                                   | 16 |
| 3.7    | Side Views.....                                       | 16 |
| 3.8    | Internal Chassis View.....                            | 17 |
| 3.9    | Rails and Cable Management.....                       | 17 |
| 3.9.1  | ReadyRails Sliding Rails.....                         | 17 |
| 3.9.2  | ReadyRails Static Rails.....                          | 17 |
| 3.10   | Rack View.....  | 18 |
| 3.10.1 | Sliding Rails.....                                    | 18 |
| 3.10.2 | Static Rails.....                                     | 18 |
| 3.11   | Fans.....   | 19 |
| 3.12   | Control Panel.....                                    | 19 |
| 3.12.1 | LED Panel Configuration.....                          | 20 |
| 3.12.2 | LCD Panel Configuration.....                          | 20 |
| 3.13   | Security.....   | 21 |
| 3.13.1 | Cover Latch.....                                      | 21 |
| 3.13.2 | Bezel.....  | 21 |
| 3.13.3 | Hard Drive.....                                       | 21 |
| 3.13.4 | Trusted Platform Module (TPM).....                    | 21 |
| 3.13.5 | Power Off Security.....                               | 21 |
| 3.13.6 | Intrusion Alert.....                                  | 21 |
| 3.13.7 | Secure Mode.....                                      | 22 |
| 3.14   | USB Key.....  | 22 |
| 3.15   | Battery.....  | 22 |
| 3.16   | Field Replaceable Units (FRU).....                    | 22 |
| 3.17   | User Accessible Jumpers, Sockets, and Connectors..... | 22 |
| 4      | Power, Thermal, Acoustic.....                         | 23 |
| 4.1    | Power Supplies.....                                   | 23 |
| 4.2    | Power Supply Specifications.....                      | 23 |
| 4.3    | Heat Dissipation.....                                 | 24 |
| 4.4    | Environmental Specifications.....                     | 24 |
| 4.5    | ENERGY STAR® Compliance.....                          | 25 |
| 4.6    | Thermal.....  | 25 |
| 4.7    | Acoustics.....  | 25 |
| 5      | Processors.....                                       | 27 |
| 5.1    | Overview.....   | 27 |

|        |   |
|--------|---|
| Dell   |   |
| 5.2    | Features ..... 27   |
| 5.3    | Supported Processors ..... 27                                       |
| 5.4    | Processor Configurations ..... 28                                   |
| 5.5    | Processor Installation ..... 28                                     |
| 6      | Memory ..... 29   |
| 6.1    | Overview ..... 29   |
| 6.2    | DIMMs Supported ..... 29  |
| 6.3    | DIMM Slots ..... 29   |
| 6.4    | Speed ..... 30  |
| 6.5    | Sparing ..... 30  |
| 6.6    | Mirroring ..... 30  |
| 6.7    | RAID ..... 30   |
| 6.8    | Supported Configurations ..... 30                                   |
| 7      | Chipset ..... 32  |
| 7.1    | Overview ..... 32   |
| 7.2    | AMD I/O Bridges ..... 32  |
| 7.3    | HyperTransport 3 (HT3) ..... 32                                     |
| 7.4    | Southbridge Link Interface ..... 32                                 |
| 7.5    | AMD SP5100 Southbridge (SP5100) ..... 32                            |
| 8      | BIOS ..... 33   |
| 8.1    | Overview ..... 33   |
| 8.2    | Supported ACPI States ..... 34                                      |
| 8.3    | Power Management Modes ..... 34                                     |
| 8.3.1  | Dell Active Power Controller ..... 34                               |
| 8.3.2  | Power Saving BIOS Setting (OS Control) ..... 34                     |
| 8.3.3  | Maximum Performance ..... 34  |
| 9      | Embedded NICs/LAN on Motherboard (LOM) ..... 37                     |
| 10     | I/O Slots ..... 38  |
| 10.1   | Overview ..... 38   |
| 10.2   | Boot Order ..... 40   |
| 10.3   | NICs ..... 40   |
| 10.4   | NIC and LOM Enumeration ..... 40                                    |
| 10.5   | PCI Card Dimensions ..... 40  |
| 11     | Storage ..... 41  |
| 11.1   | Overview ..... 41   |
| 11.2   | RAID Configurations ..... 41  |
| 11.3   | Persistent Storage ..... 43   |
| 11.4   | Internal SD Module (Unmanaged Internal Persistent Storage) ..... 43 |
| 11.5   | LED Indicators ..... 44   |
| 11.6   | Optical Drives ..... 44   |
| 11.7   | Tape Drives ..... 44  |
| 11.8   | External Storage ..... 44   |
| 12     | Video ..... 45  |
| 13     | Rack Information ..... 46   |
| 13.1   | Overview ..... 46   |
| 13.2   | Rails ..... 46  |
| 13.2.1 | Sliding Rails ..... 46  |
| 13.2.2 | Static Rails ..... 47   |
| 13.3   | Cable Management Arm (CMA) ..... 49                                 |
| 14     | Operating Systems and Virtualization ..... 50                       |
| 15     | Systems Management ..... 51   |

## Dell

|             |  |    |
|-------------|--|----|
| 15.1        | Overview/Description.....                                  | 51 |
| 15.2        | Server Management .....                                    | 51 |
| 15.3        | Embedded Server Management.....                            | 51 |
| 15.4        | Lifecycle Controller and Unified Server Configurator ..... | 52 |
| 15.5        | iDRAC Express .....  | 52 |
| 15.6        | iDRAC6 Enterprise .....                                    | 53 |
| 16          | USB Peripherals.....                                       | 55 |
| Appendix A. | Statement of Volatility .....                              | 56 |
| Appendix B. | Certifications.....  | 60 |
| B.1         | Regulatory Certifications .....                            | 60 |
| B.2         | Product Safety Certifications .....                        | 60 |
| B.3         | Electromagnetic Compatibility .....                        | 61 |
| B.4         | Ergonomics, Acoustics and Hygienics.....                   | 61 |
| Appendix C. | Additional Information and Options.....                    | 62 |

## Tables

|           |  |    |
|-----------|--|----|
| Table 1.  | Feature Comparison to SC1435, R410, and R610.....          | 8  |
| Table 2.  | Product Features Summary .....                             | 11 |
| Table 3.  | Power Supply Status.....                                   | 16 |
| Table 4.  | Power Supply Specifications .....                          | 23 |
| Table 5.  | Heat Dissipation .....                                     | 24 |
| Table 6.  | Environmental Specifications .....                         | 24 |
| Table 7.  | Acoustical Performance .....                               | 26 |
| Table 8.  | Supported Processor Description and Features .....         | 27 |
| Table 9.  | DIMMS Supported .....                                      | 29 |
| Table 10. | Supported Configurations (1 Processor) .....               | 30 |
| Table 11. | Supported Configurations (2 Processors).....               | 31 |
| Table 12. | BIOS Power Management Features .....                       | 34 |
| Table 13. | BIOS Power Management Profiles .....                       | 35 |
| Table 14. | Supported Expansion Cards .....                            | 38 |
| Table 15. | Supported Hard Drives .....                                | 41 |
| Table 16. | RAID Configurations .....                                  | 41 |
| Table 17. | Graphics Video Modes.....                                  | 45 |
| Table 18. | Supported Racks .....                                      | 48 |
| Table 19. | Rail Adjustability Ranges and Depth .....                  | 49 |
| Table 20. | Unified Server Configurator Features and Description ..... | 52 |
| Table 21. | Features List for BMC, iDRAC, and vFlash.....              | 53 |
| Table 22. | R415 Volatility Table.....                                 | 56 |
| Table 23. | Product Safety Certifications .....                        | 60 |
| Table 24. | Electromagnetic Compatibility Certifications .....         | 61 |
| Table 25. | Ergonomics, Acoustics and Hygienics .....                  | 61 |
| Table 26. | Industry Standards.....                                    | 62 |

## Figures

|           |  |    |
|-----------|--|----|
| Figure 1. | R415 Chassis Dimensions.....                 | 14 |
| Figure 2. | Front View (Cabled HDD with LED).....        | 15 |
| Figure 3. | Front View (Hot-Plug HDD with LCD) .....     | 15 |
| Figure 4. | Front View (With Optional Bezel) .....       | 15 |
| Figure 5. | Back View (Non-Redundant Power Supply) ..... | 15 |

Dell

Figure 6. Back View (Redundant Power Supply) ..... 16  
Figure 7. Left Side View..... 16  
Figure 8. Right Side View ..... 16  
Figure 9. Internal Chassis View ..... 17  
Figure 10. R415 Mounted in A3 Sliding Rails ..... 18  
Figure 11. Back View of R415 Mounted in A3 Sliding Rails with CMA..... 18  
Figure 12. R415 Mounted in A4 Static Rails (2-Post Center Mount Configuration)..... 19  
Figure 13. PowerEdge R415 Fans ..... 19  
Figure 14. LED panel Configuration ..... 20  
Figure 15. LED Panel (Detailed View)..... 20  
Figure 16. LCD Panel Configuration ..... 20  
Figure 17. LCD Panel (Detailed View)..... 20  
Figure 18. R415 Sliding Rails with Optional CMA ..... 46  
Figure 19. 1U Threaded Rack Adapter Brackets Kit..... 47  
Figure 20. R415 Static Rails ..... 48

# 1 Product Comparison

## 1.1 Overview

The Dell™ PowerEdge™ R415 is a 2-socket 1U rack server that is designed to deliver outstanding value. The R415 is built with the latest AMD Opteron™ series processors for remarkable price for performance, and it features hot-swap hard drives and redundant power supplies to provide availability options for better business data protection.

The R415 packs other enterprise-class features, such as advanced systems management capabilities and an optional interactive LCD screen for easy system monitoring. These features help meet the needs of many small to mid-sized businesses as well as address many data center demands with superior stability, efficiency and long-term business value.

### 1.1.1 Designed to Go the Distance

You've told us you need a server manufacturer that inspires confidence through its reliability, availability, and quality of products. That is why we have designed the PowerEdge R415 for optimal reliability and ease of use, incorporating customer-inspired features that range from robust metal hard-drive carriers and industrial-quality materials to embedded diagnostics and an optional interactive LCD screen.

Our reliability goals are simple: Deliver quality products that stand the test of time.

- A Unified Server Configurator (USC) helps minimize downtime by offering embedded and persistent diagnostics with no media requirements.
- A one-touch quality-control process enables single-person responsibility for an entire server build.
- Every Dell server model is tested and re-tested before it leaves the factory.
- Our operating system, application and software integration testing, and validation help ensure that everything works together right out of the box.
- A focus on product longevity provides longer, fully supported product lifecycles for better investment protection.

### 1.1.2 Efficient from the Inside Out

The PowerEdge R415 was designed to provide you with a multitude of time- and energy-saving options, not only inside the server, but outside as well.

Inside the server, we have Energy Smart technologies to help you better manage power. This includes low-wattage processors, support for low-voltage DIMMs, and efficient fans that spin in accordance with server workload demands. Internal shrouding and logical component layouts aid with airflow direction, helping to cool the server. Energy-efficient power supplies use power effectively without compromising business productivity.

Outside the server, we have put the external ports, power supplies, and LED lights or LCD screens in the same locations as other 11th generation PowerEdge servers for a familiar server-to-server usability and commonality, as well as for easy installation and deployment. The hard drives across the 11G servers are also interchangeable, since they share the same drive carriers.

### 1.1.3 Easy to Manage

As an IT professional, you do not have a lot of time to spend managing and maintaining your systems. That is why the Dell systems-management portfolio focuses on two core principles to make your life easier: simplicity and cost-effectiveness.

The optional Lifecycle Controller helps you perform system diagnostics, hardware configuration, and system deployment in a pre-operating-system environment from an easy-to-use interface called the Unified Server Configurator (USC). This helps eliminate the need to use and maintain multiple pieces of CD/DVD media, and helps get your server up and running fast.

An optional interactive LCD screen on the front of the server allows for easy setup, monitoring, and maintenance. Plain-language diagnosis and a programmable messaging system can help you address issues quickly to simplify day-to-day monitoring.

The Dell Management Console, which is included with every Dell server, provides you with a consolidated console view of your IT infrastructure.

Automated update notification from [Support.Dell.com](http://Support.Dell.com) provides you with the latest updates for firmware, drivers and BIOS so your systems are always running at their best.

## 1.2 Comparison

**Table 1. Feature Comparison to SC1435, R410, and R610**

| Feature          | SC1435<br>(predecessor)    | R410   | R415   | R610  |
|------------------|----------------------------|--|--|---|
| Processor        | AMD Opteron™ 2000 series   | Intel® Xeon® processor 5500 and 5600 series                                  | AMD Opteron™ 4100 series   | Intel® Xeon® processor 5500 and 5600 series |
| Form Factor      | 1U rack                    | 1U rack  | 1U rack  | 1U rack                                     |
| # Sockets        | 1 or 2                     | 1 or 2   | 1 or 2   | 1 or 2                                      |
| # Cores          | 2 or 4                     | 2 or 4   | 4 or 6   | 2 or 4                                      |
| Front Side Bus   | HyperTransport 1GBz        | Intel® QuickPath Interconnect (QPI) 6.4GT/s                                  | HyperTransport 3 (HT3) 5.2GT/s   | Intel® QuickPath Interconnect (QPI) 6.4GT/s |
| L2/L3 Cache      | 1.5MB per core/6MB         | Up to 12MB   | 512KB per core/6MB   | Up to 12MB                                  |
| Chipset          | Broadcom® HT-2100, HT-1000 | Intel® 5500  | AMD SR 5670  | Intel® 5520                                 |
| DIMMs            | 8 DDR2 RDIMM 667MHz        | 4+4 DDR3 UDIMM or RDIMM 1333/1066/800MHz                                     | 8 x DDR3 UDIMM, RDIMM, or LV RDIMM 1333/1066/800/667MHz                      | 6+6 DDR3 UDIMM or RDIMM 1333/1066/800MHz    |
| Min/Max RAM      | 512MB/32GB                 | 1GB/128GB  | 1GB/128GB <sup>1</sup>   | 1GB/192GB                                   |
| HD Bays          | 2 x 3.5"                   | 4 x 3.5" or 4 x 2.5" Optional hot-plug Supports 2.5" drives with HDD carrier | 4 x 3.5" or 4 x 2.5" Optional hot-plug Supports 2.5" drives with HDD carrier | 6 x 2.5" hot-plug                           |
| HD Types         | SATA, SAS                  | SATA, SAS, SSD   | SATA, SAS, SSD   | SAS, SSD                                    |
| Ext Drive Bay(s) | 1 for slim optical drive   | 1 for slim optical drive   | 1 for slim optical drive   | 1 for slim optical drive                    |



| Feature                                   | SC1435<br>(predecessor)                                 | R410   | R415   | R610   |
|---|---|--|--|--|
| <b>Embedded HD Controller</b>             | Chipset-based SATA                                      | Chipset-based SATA   | Chipset -based SATA  | SAS 6/iR   |
| <b>Optional Storage Controller</b>        | RAID:<br>SAS 5/iR<br>SAS 6/iR                           | Non-RAID:<br>SAS 5/E<br>LSI 2032 (for tape backup unit only)<br><br>RAID:<br>SAS 6/iR Modular<br>PERC 6/i<br>PERC 6/E<br>PERC H200<br>PERC H700<br>PERC H800 | Non-RAID:<br>LSI 2032 (for tape backup unit only)<br><br>RAID:<br>SAS 6/iR Modular<br>PERC S300<br>PERC H200<br>PERC H700<br>PERC H800 | Non-RAID:<br>SAS 5/E<br>LSI 2032 (for tape backup unit only)<br><br>RAID:<br>SAS 6/iR<br>PERC 6/i<br>PERC 6/E<br>PERC H200<br>PERC H700<br>PERC H800 |
| <b>Availability</b>                       | Toolless chassis, quad-pack LED for diagnostic          | Hot-plug hard drives, redundant power supplies, quad-pack LED diagnostic or LCD (with hot-plug hard drive chassis), memory mirroring                         | Hot-plug hard drives, redundant power supplies, quad-pack LED diagnostic or LCD (with hot-plug hard drive chassis), memory mirroring   | Hot-plug hard drives, redundant power supplies, LCD diagnostic, memory mirroring or sparing, internal SD card for embedded Hypervisor                |
| <b>Server Management</b>                  | BMC, IPMI 2.0 compliant, Dell Server Assistant          | BMC, IPMI 2.0 compliant, full Dell OpenManage™ suite;<br>Optional: iDRAC6 Express, iDRAC6 Enterprise, vFlash   | BMC, IPMI 2.0 compliant, full Dell OpenManage™ suite;<br>Optional: iDRAC6 Express, iDRAC6 Enterprise, vFlash                           | iDRAC6 Express, BMC, IPMI 2.0 compliant, full Dell OpenManage™ suite;<br>Optional: iDRAC6 Enterprise, vFlash   |
| <b>I/O Slots</b>                          | 1 PCIe x8 or one PCI-X 64/133; full height, half length | 1 x PCIe x16 (true x16, Gen2); full height, half length  | 1 x PCIe x16 (true x16, Gen2); full height, half length  | 2 x PCIe x8; full height, half length  |
| <b>NIC/LOM</b>                            | 2 x GbE LOMs<br>Optional: various NICs available        | 2 x GbE LOMs<br>Optional: various NICs available   | 2 x GbE LOMs<br>Optional: various NICs available   | 2 x GbE LOMs w/ TOE<br>Optional: various NICs available  |
| <b>USB</b>                                | 2 front, 2 rear   | 2 front, 2 rear, 2 internal  | 2 front, 2 rear, 2 internal  | 2 front, 2 rear, 1 internal  |
| <b>Hypervisor (with internal SD card)</b> | No  | No   | No   | Yes  |

| Feature                       | SC1435<br>(predecessor)                                   | R410   | R415   | R610  |
|-------------------------------|---|--|--|---|
| <b>Power Supplies</b>         | Non-redundant<br>600W<br>Auto Ranging<br>(90V-264V)       | Non-redundant<br>480W (80+ SILVER)<br>Optional redundant<br>500W (80+ GOLD)<br>Auto Ranging<br>(100V-240V) | Non-redundant<br>480W (80+ SILVER)<br>Optional redundant<br>500W (80+ GOLD)<br>Auto Ranging<br>(100V-240V) | Redundant 502W<br>(high efficiency)<br>Redundant 717W<br>(high capacity)  |
| <b>Fans</b>                   | Non-redundant,<br>non-hot-pluggable                       | Non-redundant,<br>non-hot-pluggable  | Non-redundant,<br>non-hot-pluggable  | Redundant, hot-<br>pluggable  |
| <b>Dimensions<br/>(HxWxD)</b> | 42.6 x 426.2 x<br>609.6 (mm)<br>1.68 x 16.78 x 24<br>(in) | 43.0 x 434.0 x<br>627.1 (mm)<br>(without ear,<br>without bezel)<br>1.69 x 17.09 x<br>24.69 (in)            | 43.0 x 434.0 x 627.1<br>(mm) (without ear,<br>without bezel)<br>1.69 x 17.09 x 24.69<br>(in)               | 42.6 x 482.4 x 772<br>(mm) (with<br>latches, bezel,<br>and power supply<br>handles)<br>1.68 x 18.99 x<br>30.39 (in) |
| <b>Weight</b>                 | Max: 14.1Kg<br>(31.0lbs)                                  | Max: 15.9Kg<br>(35.02lbs)  | Max: 15.9Kg<br>(35.02lbs)  | Max: 17.69Kg<br>(39lbs)   |

<sup>1</sup> 128 GB maximum memory will be available using 16 GB DIMMs (available Q1 2011).

## 2 System Overview

Table 2 provides an overview of the PowerEdge R415 server features.

**Table 2. Product Features Summary**

| Feature                          | Technical Specification  |  |
|----------------------------------|--|--|
| Form Factor                      | 1U rack  |  |
| Processors                       | AMD Opteron™ 4100 series processors  |  |
| Processor Sockets                | 2  |  |
| Front Side Bus or HyperTransport | HyperTransport-3 Links   |  |
| Cache                            | L2: 512K/core<br>L3: 6MB   |  |
| Chipset                          | AMD (SR5670 and SP5100)  |  |
| Memory <sup>1</sup>              | Up to 128GB <sup>2</sup> (8 DIMM slots) 1GB/2GB/4GB/8GB/16GB <sup>2</sup> 1333MHz  |  |
| I/O Slots                        | 1 x PCIe G2 slot:<br>Slot 1: PCIe x16<br>Slot 2: Proprietary for embedded SAS 6/iR or PERC S300 modular card only  |  |
| RAID Controller                  | Internal Controllers:<br>PERC H200 (6Gb/s)<br>PERC H700 (6Gb/s) (non-volatile battery-backed cache: 512MB, 1G)<br>SAS 6/iR<br>PERC S300 (software-based) | External Controllers:<br>PERC H800 (6Gb/s) (non-volatile battery-backed cache: 512MB, 1G)<br>External HBA (non-RAID):<br>6GB/s SAS HBA |
| Drive Bays                       | Up to four 2.5" or 3.5" SAS, SATA, or SSD hard drives (cabled or optional hot-plug)  |  |
| Maximum Internal Storage         | 8TB  |  |
| Hard Drives <sup>1</sup>         | 3.5" SATA (7.2K rpm): 160GB, 250GB, 500GB, 1TB, 2TB<br>3.5" Nearline SAS (7.2K rpm): 500GB, 1TB, 2TB<br>3.5" SAS (15K rpm): 146GB, 300GB, 450GB, 600GB   | 2.5" SAS (10K rpm): 146GB, 300GB, 600GB<br>2.5" Nearline SAS (7.2K rpm): 1TB<br>2.5" SATA SSD: 50GB, 100GB                             |

| Feature            | Technical Specification  |   |
|--------------------|--|---|
| Communications     | <p><b>Optional add-in NICs:</b></p> <p>Intel® 10GBase-T Copper Single Port NIC, PCIe x8</p> <p>Intel® PRO 1000 PT Single Port Adapter, Gigabit Ethernet NIC, PCIe x1</p> <p>Intel® Gigabit ET Dual Port Server Adapter, PCIe x4</p> <p>Intel® Gigabit ET Quad Port Server Adapter, PCIe x4</p> <p>Intel® Ethernet X520 DA2 Dual-Port 10 Gigabit Server Adapter</p> <p>Intel® X520-T2 Dual-Port 10 Gigabit Ethernet Server Adapter</p> <p>Broadcom® BCM5709C IPV6 Gigabit Copper Dual Port with TOE and iSCSI Offload, PCIe x4</p> <p>Broadcom® BCM5709C IPV6 Gigabit Copper Dual Port NIC with TOE, PCIe x4</p> <p>Broadcom® BCM5709C 10/100/1000BASET Quad Port NIC</p> <p>Broadcom® NetXtreme™ II 57711 Dual-Port SFP+/Direct Attach 10Gb Ethernet PCIe with TOE and iSCSI Offload</p> | <p><b>Optional add-in HBAs:</b></p> <p>Brocade® 1020 10G Converged Network Adapter (CNA)-dual port</p> <p>Emulex® LPe11002 FC4 HBA, Dual Port</p> <p>Emulex® LPe1150 FC4 HBA, Single Port</p> <p>Emulex® LPe12000 8Gbps FC HBA, Single Port</p> <p>Emulex® LPe12002 8Gbps FC HBA, Dual Port</p> <p>Emulex® OCE10102FXD, 10G PCI-e FCoE CNA, Dual Port</p> <p>Qlogic® QLE220 FC4 HBA, Single Port</p> <p>Qlogic® QLE2460 FC4 HBA, Single Port</p> <p>Qlogic® QLE2462 FC4 HBA, Dual Port</p> <p>Qlogic® QLE2560 8Gbps FC HBA, Single Port</p> <p>Qlogic® QLE2562 8Gbps FC HBA, Dual Port</p> <p>Qlogic® QLE8152 8Gbps FC HBA, Dual Port</p> <p>Brocade® FC HBA BR815</p> <p>Brocade® FC HBA BR825</p> |
| Power Supply       | Non-redundant 480W (80+ BRONZE) or<br>Optional redundant 500W (80+ SILVER)   |   |
| Availability       | Hot-plug hard drives, hot-plug redundant power, ECC memory, quad-pack LED diagnostic (interactive LCD only with hot-plug HDD chassis)  |   |
| Video              | Matrox® G200eW with 8MB memory   |   |
| Remote Management  | Optional: iDRAC6 Express, iDRAC6 Enterprise, and vFlash  |   |
| Systems Management | <p>Dell OpenManage™ featuring Dell Management Console</p> <p>BMC, IPMI 2.0 compliant</p> <p>Lifecycle Controller enabled with optional iDRAC6 Express or iDRAC6 Enterprise and vFlash</p> <p>Unified Server Configurator</p>   |   |
| Rack Support       | <p>ReadyRails™ sliding rails for 4-post racks with support for optional cable management arm, or</p> <p>ReadyRails™ static rails for 4-post and 2-post racks</p>   |   |

| Feature  | Technical Specification   |
|--|---|
| Operating Systems  | Microsoft® Windows® Small Business Server 2008<br>Microsoft® Windows Server® 2008 SP2, x86/x64 (x64 includes Hyper-V™)<br>Microsoft® Windows Server® 2008 SP2 R2, x64 (includes Hyper-V™ v2)<br>Microsoft® Windows® HPC Server 2008<br>Novell® SUSE® Linux® Enterprise Server<br>Red Hat® Enterprise Linux®<br><b>Optional Embedded Hypervisors:</b><br>Citrix® XenServer®<br>VMware® vSphere™ 4.1 (including VMware ESX® 4.1 or VMware ESXi™ 4.1)<br>For more information on the specific versions and additions, visit <a href="http://www.dell.com/OSsupport">www.dell.com/OSsupport</a> . |
| Featured Database Application  | Microsoft® SQL Server® solutions (see <a href="http://Dell.com/SQL">Dell.com/SQL</a> )  |
| <p><sup>1</sup>GB means 1 billion bytes and TB equals 1 trillion bytes; actual capacity varies with preloaded material and operating environment and will be less.</p> <p><sup>2</sup>128 GB maximum memory will be available using 16 GB DIMMs (available Q1 2011).</p> |   |

## 3 Mechanical

### 3.1 Chassis Description

The PowerEdge R415 chassis was designed to deliver a value-based, high-performance server that also offers a level of redundancy. The PowerEdge R415 is available in two chassis configurations:

- Cabled hard drive chassis with LED module
- Hot-plug hard drive chassis with LCD module

Common features for the two available chassis include the following:

- Four 2.5” or 3.5” SATA or SAS hard drives (cabled or hot-plug)
- 2.5” SSD hard drives
- Power supply (non-redundant or redundant)
- Dual gigabit LOMs without TOE acceleration
- Four DIMM slots supporting each processor
- Trusted Platform Module (TPM); in China, the S-TPM (Socket TPM) is used
- Riser card for optional PCIe expansion card
- Optional iDRAC6 Enterprise and iDRAC6 Express card (mounted on planar without PCI slot occupied)
- Support for 11G slim static and slim sliding rails

### 3.2 Dimensions and Weight

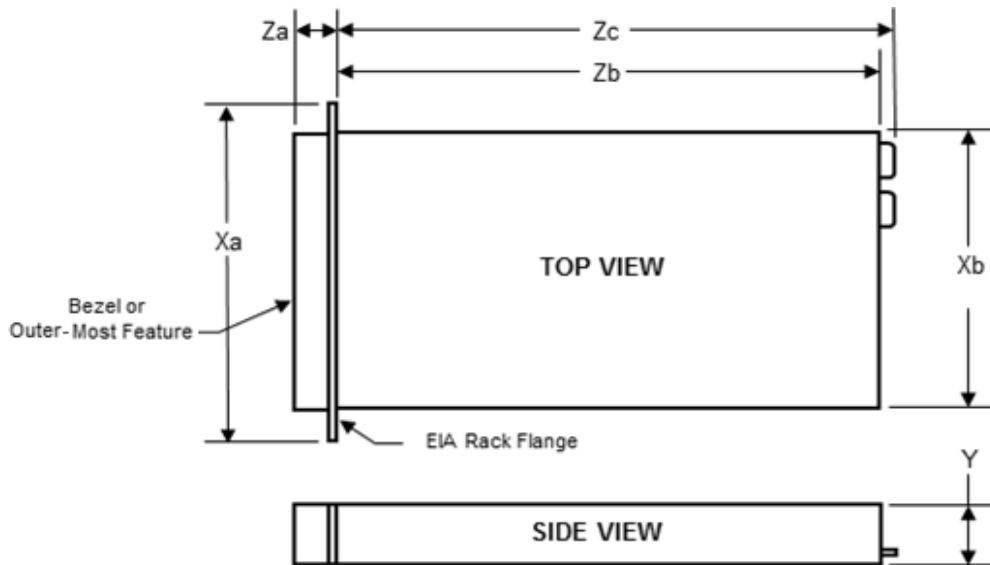

| Xa      | Xb      | Y      | Za w/ bezel | Za w/o bezel | Zb*     | Zc      | Max Weight |
|---------|---------|--------|-------------|--------------|---------|---------|------------|
| 482.4mm | 434.0mm | 43.0mm | 35.0mm      | 20.1mm       | 606.0mm | 641.9mm | 15.9Kg     |

Figure 1. R415 Chassis Dimensions

\*Zb measures to the nominal back wall external surface where the motherboard I/O connectors reside.

### 3.3 Front Panel View and Features

The PowerEdge R415 is available in two chassis configurations: cabled hard drive and hot-plug hard drive. The cabled hard drive chassis includes an LED control panel (Figure 2), and the hot-plug hard drive chassis includes an LCD control panel (Figure 3). The bezel is optional for both system configurations. See Figure 4.



Figure 2. Front View (Cabled HDD with LED)



Figure 3. Front View (Hot-Plug HDD with LCD)



Figure 4. Front View (With Optional Bezel)

See the Front-Panel Features and Indicators section in the About Your System chapter of the *PowerEdge R415 Hardware Owner's Manual* on [Support.Dell.com](http://Support.Dell.com) for more information.

### 3.4 Back Panel View and Features

The PowerEdge R415 is available with two power-supply configurations: non-redundant and redundant. See Figure 5 (non-redundant power supply) and Figure 6 (redundant power supply).



Figure 5. Back View (Non-Redundant Power Supply)







**Figure 6. Back View (Redundant Power Supply)**

See the Back-Panel Features and Indicators section in the About Your System chapter of the *PowerEdge R415 Hardware Owner's Manual* on [Support.Dell.com](http://Support.Dell.com) for more information.

### 3.5 Power Supply Indicators

The PowerEdge R415 power supplies (redundant and non-redundant) have one status bi-color LED: green for AC power present and amber for a fault.

**Table 3. Power Supply Status**

| LED   | Power Supply Status  |
|---|--|
|  | AC Power is not present                                    |
|  | AC Power is present  |
|  | Fault of any kind is detected                              |
|  | DC Power is applied to the system                          |
|  | Redundant power supply mismatch (when hot-plugged/swapped) |

See the Power Indicator Codes section in the About Your System chapter of the *PowerEdge R415 Hardware Owner's Manual* on [Support.Dell.com](http://Support.Dell.com) for more information.

### 3.6 NIC Indicators

See the NIC Indicator Codes section in the About Your System chapter of the *PowerEdge R415 Hardware Owner's Manual* on [Support.Dell.com](http://Support.Dell.com) for more information.

### 3.7 Side Views

Side views of the PowerEdge R415 are shown in Figure 7 and Figure 8.



**Figure 7. Left Side View**



**Figure 8. Right Side View**



## 3.8 Internal Chassis View

Figure 9 shows the internal chassis view.

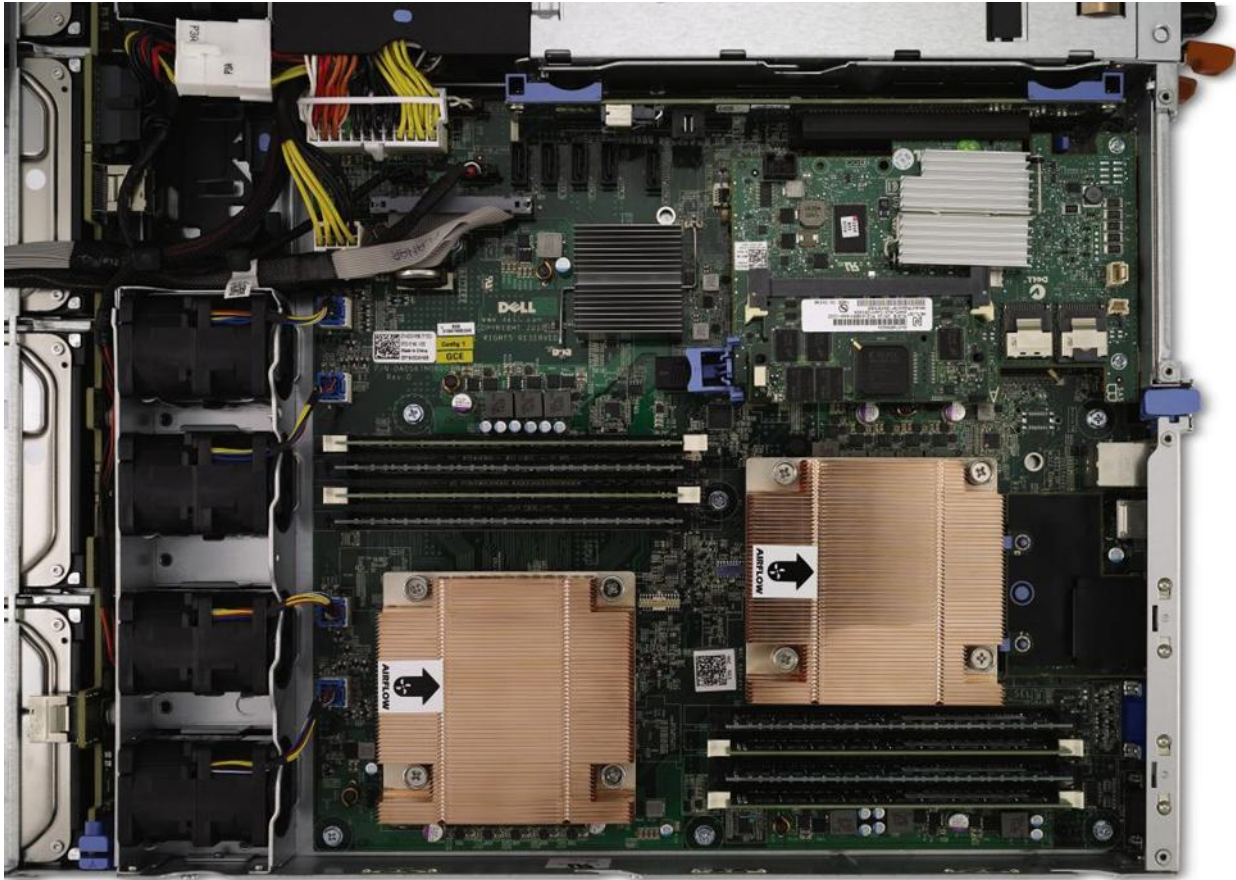

Figure 9. Internal Chassis View

## 3.9 Rails and Cable Management

### 3.9.1 ReadyRails Sliding Rails

ReadyRails™ Sliding Rails for 4-post racks include the following support:

- Toolless installation in 19" EIA-310-E compliant square or unthreaded round hole 4-post racks, including all generations of Dell racks
- Toolled installation in 19" EIA-310-E compliant threaded hole 4-post racks (requires the 1U Threaded Rack Adapter Brackets Kit)
- Full extension of the system out of the rack to allow serviceability of key internal components
- Optional cable management arm (CMA)

### 3.9.2 ReadyRails Static Rails

ReadyRails™ Static Rails for 4-post and 2-post racks include the following support:

- Toolless installation in 19" EIA-310-E compliant square or unthreaded round hole 4-post racks including all generations of Dell racks
- Toolled installation in 19" EIA-310-E compliant threaded hole 4-post and 2-post racks

For more information on rails, see section 13.2.

## 3.10 Rack View

### 3.10.1 Sliding Rails

See Figure 10 and Figure 11 for views of the PowerEdge R415 mounted in A3 sliding rails.



Figure 10. R415 Mounted in A3 Sliding Rails



Figure 11. Back View of R415 Mounted in A3 Sliding Rails with CMA

### 3.10.2 Static Rails

The R415 static rails are a stab-in design, but unlike the sliding rails, they do not include middle (intermediate) rail members. After the inner (chassis) rail members have been attached to the sides of the chassis, they are inserted directly into the outer (cabinet) rail members installed in the rack. See Figure 12 for a view of the R415 mounted in A4 static rails.



Figure 12. R415 Mounted in A4 Static Rails (2-Post Center Mount Configuration)

### 3.11 Fans

There are total of six fans with redundant power supplies in the system and four fans with non-redundant power supplies.

Figure 13 shows the PowerEdge R415 fans. The four fans at right are the fans for the system, specifically for the processors and memory modules. The two fans at left are present when the system is configured with redundant power supplies, for which they provide cooling.

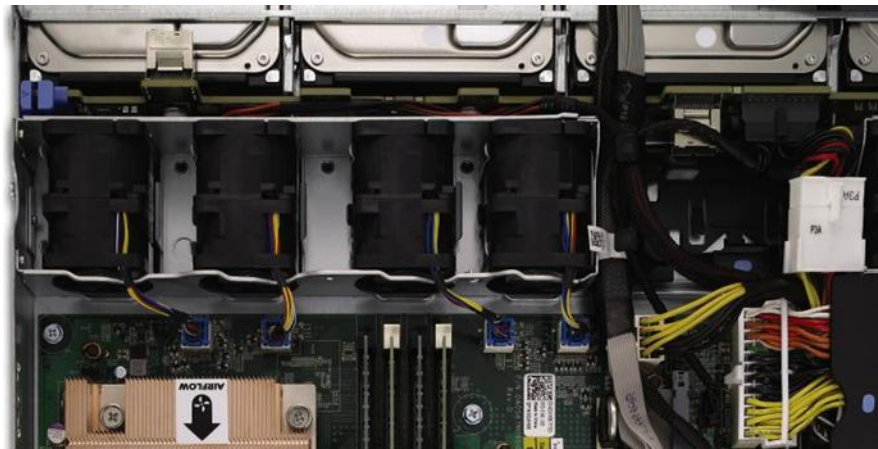

Figure 13. PowerEdge R415 Fans

### 3.12 Control Panel

The PowerEdge R415 is available in an LED panel configuration and an optional LCD panel configuration.

### 3.12.1 LED Panel Configuration

Figure 14 and Figure 15 show the LED panel.



Figure 14. LED panel Configuration



Figure 15. LED Panel (Detailed View)

For a complete description of LED indicators, their causes, and possible courses of action to take to resolve an error, see the Diagnostic Lights (Optional) section in the About Your System chapter in the *PowerEdge R415 Hardware Owner's Manual* on [Support.Dell.com](http://Support.Dell.com).

### 3.12.2 LCD Panel Configuration

Figure 16 and Figure 17 show the LCD panel.



Figure 16. LCD Panel Configuration



Figure 17. LCD Panel (Detailed View)

The LCD panel is located on the front of the system chassis to provide user access to buttons, display, and I/O interfaces. Features of the LCD panel include the following:

- ACPI-compliant power button with an integrated green power LED (controlled by iDRAC6)
- 128x20 pixel LCD screen with controls
- Two navigation buttons
- Select button
- System ID button
- Non-maskable Interrupt (NMI) button (recessed)
- Ambient temperature sensor

Dell

The LCD panel is a graphics display controlled by iDRAC6. Error codes can be sent to the display by either iDRAC6 or BIOS.

The system's LCD panel provides system information and status messages to signify when the system is operating correctly or when the system needs attention.

BIOS has the ability to enter a secure mode through Setup, which locks the Power and NMI buttons. When in this mode, the power button can still be used to turn on the system, but it cannot be used to turn off power to the system.

For more information on the LCD panel, see the LCD Panel Features (Optional) section in the About Your System chapter in the *PowerEdge R415 Hardware Owner's Manual* on [Support.Dell.com](http://Support.Dell.com).

## 3.13 Security

For additional information regarding the PowerEdge R415 security features listed below, see the *PowerEdge R415 Hardware Owner's Manual* on [Support.Dell.com](http://Support.Dell.com).

### 3.13.1 Cover Latch

The PowerEdge R415 comes with a coin-lock entry latch on the top cover of the unit and provides security for the entire system. The lock provides for toolless access to the chassis.

### 3.13.2 Bezel

A metal bezel is an available option and is mounted to the chassis front to provide the Dell ID. A lock on the bezel prevents unauthorized access to system peripherals and the control panel. System status remains viewable when the bezel is installed.

### 3.13.3 Hard Drive

Hot-plug hard drives are only accessible by opening the bezel, thus locking the bezel secures the hard drives. Cabled hard drives are only accessible by opening the top cover, thus locking the top cover will secure the hard drives.

### 3.13.4 Trusted Platform Module (TPM)

The TPM is used to generate/store keys, protect/authenticate passwords, and create/store digital certificates. TPM can also be used to store the Microsoft® BitLocker™ keys for hard drive encryption features in Microsoft® Windows Server® 2008. TPM is enabled through a BIOS option and uses HMAC-SHA1-160 for binding. In China, the S-TPM (Socket TPM) is used.

### 3.13.5 Power Off Security

The control panel is designed such that the power switch cannot be accidentally activated. The lock on the bezel secures the power button behind the bezel. In addition, there is a setting in the CMOS setup that disables the power button function.

### 3.13.6 Intrusion Alert

A chassis intrusion switch is located at the front panel board. The switch detects when the top cover is opened.

### 3.13.7 Secure Mode

BIOS can enter a secure boot mode through setup. This mode includes the option to lock out the power and NMI switches on the control panel or to set up a system password.

### 3.14 USB Key

Dell does not offer USB keys for factory installation. The PowerEdge R415 supports two internal USB connectors which can be used for USB keys.

### 3.15 Battery

A replaceable coin-cell CR2032 3V battery is mounted on the planar to provide backup power for the Real-Time Clock and CMOS RAM on the AMD SP5100 chip.

### 3.16 Field Replaceable Units (FRU)

Parts available for field replacement include:

- Backplane
- CMOS battery
- Expansion card
- Front bezel
- Hard drives
- I/O panel
- Memory
- Optical disk drive
- Power distribution board
- Power supply
- Processor
- Processor shroud
- System board
- System cover
- System fan

For detailed information on replacing parts for the PowerEdge R415, see the Installing System Components chapter in the *PowerEdge R415 Hardware Owner's Manual* on [Support.Dell.com](http://Support.Dell.com).

### 3.17 User Accessible Jumpers, Sockets, and Connectors

See the Jumpers and Connectors chapter in the *PowerEdge R415 Hardware Owner's Manual* on [Support.Dell.com](http://Support.Dell.com).

## 4 Power, Thermal, Acoustic

### 4.1 Power Supplies

The PowerEdge R415 is powered by either a non-redundant 480W power supply or an optional redundant 500W power supply.

The power supply subsystem provides power to the planar, the four internal hard drive bays, and one slim optical disk drive bay. Power is soft-switched, allowing power cycling using a switch on the front of the system enclosure or through software control (through server management functions). The power system is compatible with industry standards, such as ACPI and Server 2000.

For a redundant power supply configuration, the second power supply provides hot-pluggable power redundancy. In redundant mode, the system distributes the power load across both power supplies to maximize efficiency. When a power supply is removed with the system powered on, the full power load is picked up by the remaining power supply.

If using only one hot-plug power supply, the power supply is installed in the PS1 location and a blank module (metal cover) is installed in the PS2 location for factory consistency. Electrically, the system can operate with a single power supply in either bay. The power supply has automatic input voltage detection. An auxiliary power-out receptacle is not provided on this unit.



The power supply in the chassis has been rated as 82% efficient at 20% and 100% loads, and 85% efficient at a 50% load under 115V AC input line. Redundant power efficiency is 88% at 20% and 100% loads, and 92% efficiency at a 50% load under 230V AC input line.

Field replaceable unit (FRU) data is stored in the memory of the power supply microcontroller. Additionally, the power supply firmware can be updated by the baseboard management controller (BMC) over the PMBus.

### 4.2 Power Supply Specifications

Table 4 shows the power supply specifications.

**Table 4. Power Supply Specifications**

| Feature                | Non-Redundant Power Supply   | Redundant Power Supply   |
|------------------------|--|--|
| Dimensions             | L-260 <sup>1</sup> x W-106 x H-40.0 (mm)   | L-260 <sup>1</sup> x W-54.5 x H-38.0 (mm)  |
| Status Indicators      | 1 x bi-color LED   | 1 x bi-color LED   |
| Integrated Fans        | None   | None   |
| Fixed Input Plug       | IEC-C14<br> | IEC-C14<br> |
| AC Cord Rating         | 15A @ 120VAC,<br>10A @ 240VAC  | 15A @ 120VAC,<br>10A @ 240VAC  |
| Input Voltage          | 90-264VAC  | 90-264VAC  |
| Auto-ranging           | Yes  | Yes  |
| Line Frequency         | 47-63Hz  | 47-63Hz  |
| Maximum Inrush Current | Under typical line conditions and over the entire system                                       | Under typical line conditions and over the entire system   |

| Feature                                | Non-Redundant Power Supply   | Redundant Power Supply   |
|--|--|--|
|  | ambient operating range, the inrush current may reach 25A per power supply for 10ms or less. | ambient operating range, the inrush current may reach 25A per power supply for 10ms or less. |
| Hot-plug Capability                    | No   | Yes  |
| Output Power                           | 480W   | 500W   |
| Efficiency<br>20% to 100% Load         | 82-85% @115VAC<br>82-85% @ 230VAC  | 86-90% @115VAC<br>88-92% @ 230VAC  |
| Energy Star Certification & Compliance | 80+ Bronze   | 80+ Silver   |

<sup>†</sup> Does not include the power supply handle or ejection tab.

### 4.3 Heat Dissipation

Table 5 details heat dissipation for the PowerEdge R415.

**Table 5. Heat Dissipation**

| Description      | Non Redundant Power Supply   | Redundant Power Supply       |
|------------------|------------------------------|------------------------------|
| Wattage          | 480W                         | 500W                         |
| Voltage          | 100-240VAC, 50-60Hz, 7.5-3.8 | 100-240VAC, 50-60Hz, 7.5-3.8 |
| Heat Dissipation | 1637 BTU/hr maximum          | 1706 BTU/hr maximum          |

### 4.4 Environmental Specifications

Table 6 summarizes the environmental specifications for the PowerEdge R415.

**Table 6. Environmental Specifications**

| Temperature       |   |
|-------------------|---|
| Operating         | 10° to 35° C (50° to 95° F) with a maximum temperature gradation of 10° C per hour<br><b>Note:</b> For altitudes above 2950 feet, the maximum operating temperature is derated 1° F/550 ft. |
| Storage           | -40° to 65° C (-40° to 149° F) with a maximum temperature gradation of 20° C per hour   |
| Relative Humidity |   |
| Operating         | 20% to 80% (noncondensing) with a maximum humidity gradation of 10% per hour  |
| Storage           | 5% to 95% (noncondensing) with a maximum humidity gradation of 10% per hour   |
| Maximum Vibration |   |
| Operating         | 0.26Grms at 5-350Hz in operational orientations   |
| Storage           | 1.87Grms at 10-500Hz in all orientations  |



| Maximum Shock |  |
|---------------|--|
| Operating     | Half sine shock in all operational orientations of 31G +/- 5% with a pulse duration of 2.6ms +/-10%  |
| Storage       | Half sine shock on all six sides of 71G +/- 5% with a pulse duration of 2ms +/-10%<br>Square wave shock on all six sides of 27G with velocity change @ 235 in/sec or greater |
| Altitude      |  |
| Operating     | -16 to 3048m (-50 to 10,000ft)<br>Note: For altitudes above 2950 feet, the maximum operating temperature is derated 1°F/550ft.   |
| Storage       | -16 to 10,600m (-50 to 35,000ft)   |

The airborne contaminant level is class G2 or lower as defined by ISA-S71.04-1985.

## 4.5 ENERGY STAR® Compliance

ENERGY STAR qualified configurations can be accessed from the [ENERGY STAR Compliance results](#) landing page on Dell.com.

## 4.6 Thermal

The thermal design of the PowerEdge R415 includes the following:

- Closed loop thermal control algorithm: This method uses feedback temperatures to dynamically determine proper fan speeds.
- Comprehensive thermal management: The PowerEdge R415 controls system cooling fan speed based on several different responses from critical component sensors, such as processor temperature, DIMM temperature, inlet ambient temperature, and system configurations. The thermal management adjusts proper cooling ability for the system according to what the system really needs.
- Optimized Ventilation: The R415 chassis has a custom ventilation design for optimized air flow path. Each component and peripheral is ensured sufficient air for cooling.
- Power-to-Cool: Dell continues to improve the designs and cooling efficiency for server products.

## 4.7 Acoustics

The acoustical design of the PowerEdge R415 reflects adherence to Dell's high sound-quality standards. Sound quality is different from sound power level and sound pressure level in that it describes how humans respond to annoyances in sound, like whistles, hums, etc. One of the sound quality metrics in the Dell specification is prominence ratio of a tone as shown in Table 7.

Fan speeds and noise levels ramp up during the boot process to add a layer of protection for component cooling if the system were not to boot properly. Hardware configurations affect system noise levels. The table below shows the noise levels of the R415 with different configurations.

**Table 7. Acoustical Performance**

| Configuration @ 23 ± 2 °C     |                   |         |                        | Operating Mode | L <sub>WA</sub> -UL (Bels) | L <sub>pA</sub> (dBA) | Prominent Tones |
|-------------------------------|-------------------|---------|------------------------|----------------|----------------------------|-----------------------|-----------------|
| CPU                           | RAID              | DIMM    | Power Supply           |                |                            |                       |                 |
| 1 x AMD 4122<br>4 core 2.2GHz | Embedded SAS 6/iR | 1 x 1GB | 1 x 480W Non-redundant | Idle           | 5.5                        | 39                    | None            |
|                               |                   |         |                        | Stressed       | 5.5                        | 39                    | None            |
| 2 x AMD 4122<br>4 core 2.2GHz | Embedded SAS 6/iR | 4 x 2GB | 2 x 500W Redundant     | Idle           | 5.6                        | 40                    | None            |
|                               |                   |         |                        | Stressed       | 5.6                        | 40                    | None            |
| 2 x AMD 4184<br>6 core 2.8GHz | PERC H800         | 8 x 8GB | 2 x 500W Redundant     | Idle           | 5.9                        | 46                    | None            |
|                               |                   |         |                        | Stressed       | 6.4                        | 46                    | None            |

### Definitions

Idle: Reference ISO7779 (1999) definition 3.1.7; system is running in its OS but no other specific activity.

Stressed Processor: An operating mode per ISO7779 (1999) definition 3.1.6. The software SPECPower\_ssj2008 is utilized to stress the processors. SPECPower is set to 50% loading.

L<sub>WA</sub> - UL: The upper limit sound power level (L<sub>WA</sub>) calculated per section 4.4.2 of ISO 9296 (1988) and measured in accordance to ISO 7779 (1999).

L<sub>pA</sub>: Average bystander A-weighted sound pressure level. The system is placed in a rack with its bottom at 25 cm from the floor. The acoustic transducers are at the four bystander positions, ref ISO7779 (1999) Section 8.6.2.

Prominent tone: Criteria of D.5 and D.8 of ECMA-74 9th ed. (2005) are followed to determine if discrete tones are prominent. The system is placed in a rack with its bottom at 75 cm from the floor. The acoustic transducer is at front bystander position, ref ISO7779 (1999) Section 8.6.2.

## 5 Processors

### 5.1 Overview

The PowerEdge R415 utilizes the latest four- and six-core offerings from the AMD Opteron™ 4000 series (C32).

### 5.2 Features

Key features of the C32 processor include the following:

- Performance for blades and cost-effective DP servers
  - Up to six cores per processor
  - Up to 6M L3 Cache for 6-core processors (512 KB per core L2)
  - Enhanced AMD power efficiency features:
    - CoolCore™ Technology,
    - Enhanced AMD PowerNow!™
    - APML
  - Demand-based switching for active processor power management, as well as support for ACPI P-States and C-States
    - C1E support
    - AMD CoolSpeed
  - Dual-channel U/RDDR3 up to 1333 MHz, ECC
  - Up to 3 DIMMs per channel, 6 per processor (R415 supports up to 2 DIMMs per channel, 4 per processor)
  - Low voltage (LV) DIMM support (6-core processor only)
  - Designed for thermally-constrained environments
  - 45 nm process technology
  - PCIe Gen 2 with up to 42 lanes with 9 controllers (SR5670)
  - Single series for UP and DP platforms (enterprise scalability and features for 1P)
- New C32 socket infrastructure
  - Lower power/thermal bands
  - Dual 16-bit HT3 links, up to 6.4 GT/s per link
  - Workload-optimized platforms (SR5670 chipset for expandable SMB)

### 5.3 Supported Processors

**Table 8. Supported Processor Description and Features**

| Model   | Speed  | Power | Cores | L2/L3 Cache   | HyperTransport | HyperTransport Multiplier | Memory Speed | Process |
|---------|--------|-------|-------|---------------|----------------|---------------------------|--------------|---------|
| 4122    | 2.2GHz | 95W   | 4     | 4 x 512KB/6MB | 3.2GHz         | 11x                       | 1333MHz      | 45nm    |
| 4130    | 2.6GHz | 95W   | 4     | 4 x 512KB/6MB | 3.2GHz         | 13x                       | 1333MHz      | 45nm    |
| 4162 EE | 1.7GHz | 35W   | 6     | 6 x 512KB/6MB | 3.2GHz         | 8.5x                      | 1333MHz      | 45nm    |
| 4164 EE | 1.7GHz | 35W   | 6     | 6 x 512KB/6MB | 3.2GHz         | 9x                        | 1333MHz      | 45nm    |
| 4170 HE | 2.1GHz | 65W   | 6     | 6 x 512KB/6MB | 3.2GHz         | 10.5x                     | 1333MHz      | 45nm    |
| 4174 HE | 2.3GHz | 65W   | 6     | 6 x 512KB/6MB | 3.2GHz         | 11.5x                     | 1333MHz      | 45nm    |
| 4176 HE | 2.4GHz | 65W   | 6     | 6 x 512KB/6MB | 3.2GHz         | 12x                       | 1333MHz      | 45nm    |

| Model | Speed  | Power | Cores | L2/L3 Cache   | HyperTransport | HyperTransport Multiplier | Memory Speed | Process |
|-------|--------|-------|-------|---------------|----------------|---------------------------|--------------|---------|
| 4180  | 2.6GHz | 95W   | 6     | 6 x 512KB/6MB | 3.2GHz         | 13x                       | 1333MHz      | 45nm    |
| 4184  | 2.8GHz | 95W   | 6     | 6 x 512KB/6MB | 3.2GHz         | 14x                       | 1333MHz      | 45nm    |

## 5.4 Processor Configurations

The PowerEdge R415 is a two-socket server that will operate with either a single processor or dual processors. When the R415 is configured with a single processor, the memory controller is embedded in the processor and supports 4 DIMMs (1 GB minimum and a 32 GB maximum). When two processors are installed in the system, it supports a total of 8 DIMMs (2 GB minimum and a 64 GB maximum).

## 5.5 Processor Installation

See the Processors section in the Installing System Components chapter in the *PowerEdge R415 Hardware Owner's Manual* on [Support.Dell.com](http://Support.Dell.com).

## 6 Memory

### 6.1 Overview

The PowerEdge R415 uses DDR3 memory, providing a high-performance, high-speed memory interface capable of low-latency response and high throughput.

Key features of the R415 memory system include:

- Support for up to 128 GB of memory (8 x 16 GB RDIMMS) (16 GB DIMMS available Q1 2011)
- Two channels per processor
- Registered ECC DDR3 DIMMs or Unbuffered ECC DDR3 DIMMs
- DDR3 speeds of 1066/1333 MHz
- Single rank, dual rank, and quad rank DIMMs
- Single bit error correction
- Advanced ECC (Chipkill)
- Online spare
- Parity
- Low voltage (LV) DIMM support (6-core processor only)

### 6.2 DIMMs Supported

The PowerEdge R415 supports DDR3 RDIMMs and UDIMMs. The memory interface uses 1 GB, 2 GB, 4 GB, 8 GB, and 16 GB (available Q1 2011) RDIMMs and 1 GB, 2 GB, and 4 GB UDIMMs. See Table 9.

**Table 9. DIMMS Supported**

| UDIMM                               | RDIMM   |
|-------------------------------------|---|
| 1GB, DDR3, 1333MHz, single rank     | 2GB, DDR3, 1333MHz, single rank                 |
| 2GB, DDR3, 1333MHz, single rank     | 4GB, DDR3, 1333MHz, dual rank                   |
| 4GB, DDR3, 1333MHz, dual rank       | 8GB, DDR3, 1333MHz, dual rank                   |
| 1GB, DDR3, 1333MHz, single rank, LV | 16GB, DDR3, 1066MHz, quad rank <sup>1</sup>     |
| 2GB, DDR3, 1333MHz, single rank, LV | 2GB, DDR3, 1333MHz, single rank, LV             |
| 4GB, DDR3, 1333MHz, dual rank, LV   | 4GB, DDR3, 1333MHz, dual rank, LV               |
|                                     | 8GB, DDR3, 1333MHz, dual rank, LV <sup>1</sup>  |
|                                     | 16GB, DDR3, 1066MHz, quad rank, LV <sup>1</sup> |

<sup>1</sup> Available Q1 2011

### 6.3 DIMM Slots

The DDR3 memory interface consists of two memory channels per processor socket. Each channel supports up to two RDIMMs for single/dual/quad rank or two UDIMMs. Population order is identified by the silkscreen designator and the System Information Label (SIL) located on the chassis cover.

The following DIMM population rules apply:

- Support for DDR3 1333 MHz UDIMMs or 1066/1333 MHz RDIMMs
- 2 channels, up to 2 DIMMs per channel
- Support for 1333 MHz single and dual-rank DIMMs, 1066 MHz quad-rank DIMMs

Dell

The following is not supported:

- Mixing of RDIMMs and UDIMMs
- Use of non-ECC UDIMMs

For more information on R415 memory configurations, see the System Memory section in the Installing System Components chapter in the *PowerEdge R415 Hardware Owner's Manual* on [Support.Dell.com](http://Support.Dell.com).

## 6.4 Speed

Each processor has two DDR3 channels capable of supporting speeds up to 1333 MHz. Single- and dual-rank DIMM types can support speeds up to 1333 MHz. Quad-rank DIMMs can support speeds up to 1066 MHz.

If memory modules with different speeds are installed, they will operate at the speed of the slowest installed memory module(s).

## 6.5 Sparing

Memory sparing is supported. Sparing requires a fully-populated memory configuration (8 DIMMs). See Table 10 (1 processor) and Table 11 (2 processors).

## 6.6 Mirroring

No mirroring support.

## 6.7 RAID

No RAID memory support.

## 6.8 Supported Configurations

Table 10. Supported Configurations (1 Processor)

| System Capacity | DIMM Slots |     |           |     | 1 Socket   |              |            |              |
|-----------------|------------|-----|-----------|-----|------------|--------------|------------|--------------|
|                 | Channel A  |     | Channel B |     | UDIMM      |              | RDIMM      |              |
|                 | A1         | A3  | A2        | A4  | DIMM speed | System speed | DIMM speed | System speed |
| 1GB             | 1GB        | —   | —         | —   | 1333       | 1333         | N/A        | N/A          |
| 2GB             | 1GB        | —   | 1GB       | —   | 1333       | 1333         | N/A        | N/A          |
| 2GB             | 2GB        | —   | —         | —   | 1333       | 1333         | 1333       | 1333         |
| 4GB             | 1GB        | 1GB | 1GB       | 1GB | 1333       | 1333         | N/A        | N/A          |
| 4GB             | 2GB        | —   | 2GB       | —   | 1333       | 1333         | 1333       | 1333         |
| 8GB             | 2GB        | 2GB | 2GB       | 2GB | 1333       | 1333         | 1333       | 1333         |
| 4GB             | 4GB        | —   | —         | —   | 1333       | 1333         | 1333       | 1333         |
| 8GB             | 4GB        | —   | 4GB       | —   | 1333       | 1333         | 1333       | 1333         |
| 16GB            | 4GB        | 4GB | 4GB       | 4GB | 1333       | 1066         | 1333       | 1066         |
| 16GB            | 8GB        | —   | 8GB       | —   | N/A        | N/A          | 1333       | 1333         |
| 32GB            | 8GB        | 8GB | 8GB       | 8GB | N/A        | N/A          | 1333       | 1066         |

| System Capacity   | DIMM Slots |      |           |      | 1 Socket   |              |            |              |
|-------------------|------------|------|-----------|------|------------|--------------|------------|--------------|
|                   | Channel A  |      | Channel B |      | UDIMM      |              | RDIMM      |              |
|                   | A1         | A3   | A2        | A4   | DIMM speed | System speed | DIMM speed | System speed |
| 32GB <sup>1</sup> | 16GB       | —    | 16GB      | —    | N/A        | N/A          | 1066       | 1066         |
| 64GB <sup>1</sup> | 16GB       | 16GB | 16GB      | 16GB | N/A        | N/A          | 1066       | 1066         |

<sup>1</sup> 16 GB DIMMS available Q1 2011

**Table 11. Supported Configurations (2 Processors)**

| System Capacity    | DIMM Slots |      |           |      | DIMM Slots |      |           |      | 2 Socket   |              |            |              |
|--------------------|------------|------|-----------|------|------------|------|-----------|------|------------|--------------|------------|--------------|
|                    | Channel A  |      | Channel B |      | Channel A  |      | Channel B |      | UDIMM      |              | RDIMM      |              |
|                    | A1         | A3   | A2        | A4   | B1         | B3   | B2        | B4   | DIMM speed | System speed | DIMM speed | System speed |
| 2GB                | 1GB        | —    | —         | —    | 1GB        | —    | —         | —    | 1333       | 1333         | N/A        | N/A          |
| 4GB                | 1GB        | —    | 1GB       | —    | 1GB        | —    | 1GB       | —    | 1333       | 1333         | N/A        | N/A          |
| 4GB                | 2GB        | —    | —         | —    | 2GB        | —    | —         | —    | 1333       | 1333         | 1333       | 1333         |
| 8GB                | 1GB        | 1GB  | 1GB       | 1GB  | 1GB        | 1GB  | 1GB       | 1GB  | 1333       | 1333         | N/A        | N/A          |
| 8GB                | 2GB        | —    | 2GB       | —    | 2GB        | —    | 2GB       | —    | 1333       | 1333         | 1333       | 1333         |
| 16GB               | 2GB        | 2GB  | 2GB       | 2GB  | 2GB        | 2GB  | 2GB       | 2GB  | 1333       | 1333         | 1333       | 1333         |
| 8GB                | 4GB        | —    | —         | —    | 4GB        | —    | —         | —    | 1333       | 1333         | 1333       | 1333         |
| 16GB               | 4GB        | —    | 4GB       | —    | 4GB        | —    | 4GB       | —    | 1333       | 1333         | 1333       | 1333         |
| 32GB               | 4GB        | 4GB  | 4GB       | 4GB  | 4GB        | 4GB  | 4GB       | 4GB  | 1333       | 1066         | 1333       | 1066         |
| 32GB               | 8GB        | —    | 8GB       | —    | 8GB        | —    | 8GB       | —    | N/A        | N/A          | 1333       | 1333         |
| 64GB               | 8GB        | 8GB  | 8GB       | 8GB  | 8GB        | 8GB  | 8GB       | 8GB  | N/A        | N/A          | 1333       | 1066         |
| 64GB <sup>1</sup>  | 16GB       | —    | 16GB      | —    | 16GB       | —    | 16GB      | —    | N/A        | N/A          | 1066       | 1066         |
| 128GB <sup>1</sup> | 16GB       | 16GB | 16GB      | 16GB | 16GB       | 16GB | 16GB      | 16GB | N/A        | N/A          | 1066       | 1066         |

<sup>1</sup> 16 GB DIMMS available Q1 2011

## 7 Chipset

### 7.1 Overview

The PowerEdge R415 planar incorporates a dual-IOB configuration using the AMD SR5670 chipset with I/O bridges and the SP5100 Southbridge. The SR5670 is designed to support the AMD C32 processor family, HyperTransport-3 Interface (@ 2.6GHz), DDR3 memory technology, and PCI Express Generation 2. The chipset consists of the SR5670 and the SP5100.

### 7.2 AMD I/O Bridges

The PowerEdge R415 I/O board uses the AMD SR5670 I/O Bridges (IOB) to provide links between the C32 processor(s) and I/O components. The main components of the I/O controllers are configured to use two x16 HyperTransport-3 links (to both processors), up to 42 lanes of PCI Express Gen 2, an x4 PCIe Gen 1 Southbridge Interface (SB Link), and an integrated IOAPIC.

### 7.3 HyperTransport 3 (HT3)

The HyperTransport 3 (HT3) consists of serial point-to-point interconnects for the processors and the I/O bridges. The PowerEdge R415 has a total of four HT3 links per processor which allows interconnecting each processor with each other and an option for I/O Bridge. Each I/O Bridge has a single x16 HT3 link. A full link consists of 16 lanes (full-width) in each direction with a link speed of 6.4 GT/s. The HT3 clocking for CPU HT3 and IOB HT3 are 3.2 GHz and 2.6 GHz, respectively. Therefore, the IOB HT3 link is capable of 5.2 GT/s. For routing, the HT3 links are grouped by x8 Command Address (CAD), x1 Control (CTL), and x1 Clock (CLK) for each RX and TX directions.

### 7.4 Southbridge Link Interface

The Southbridge (SB) link connects the SR5670 IOB with the AMD Southbridge SP5100. The SB Link (A-Link Express) is equivalent to an x4 PCIe Gen 1 link with a transfer rate of 1 GB/s in each direction.

### 7.5 AMD SP5100 Southbridge (SP5100)

SP5100 is a highly-integrated southbridge controller, supporting the following functions:

- PCI bus 32-bit interface Rev 2.3 running at 33 MHz
  - Serial ATA (SATA) ports with transfer rates up to 300 MB/s (R415 supports one SATA port for optical devices)
  - Five OHC (full-speed 1.1) and two EHCI (high-speed 2.0) USB host controllers, with up to 12 USB general purpose ports and 2 USB embedded ports (R415 uses 6 ports for internal and external use from the general purpose ports)
- Power management interface (ACPI 3.0b compliant)
- Integrated Micro Controller (IMC) and thermal management
  - Note:** the iDRAC interfaces the Hardware Thermal Control (HTC), not the SP5100
- I/O interrupt controller
- SMBus 2.0 controller
- Low Pin Count (LPC) interface to Super I/O, Trusted Platform Module (TPM), and SPI-VU
- Serial Peripheral Interface (SPI) support for up to two devices
- 4 MB BIOS flash connected to the SP5100 using SPI interface



## 8 BIOS

### 8.1 Overview

The PowerEdge R415 BIOS is based on the Dell BIOS core and supports the following features:

- AMD C32 processor support
- Simultaneous Multi-Threading (SMT) support
- PCI 2.3 compliant
- Plug and Play 1.0a compliant
- Multiprocessor (MP) 1.4 compliant
- Bootable from hard drive, optical drive, iSCSI drive, USB key, and SD card
- Power-management support including DBS, power inventory, and multiple power profiles:
  - Maximum performance
  - OS control (DBS)
  - Active Power Controller
  - Custom
- ACPI 2.0 support (S0, OS-S4, S5 States)
- PXE and WOL support for on-board NICs
- Memory-sparing support
- SETUP access through <F2> key at end of POST
- USB 2.0 (USB boot code is 1.1 compliant)
- F1/F2 error logging in CMOS
- Virtual KVM, CD, and floppy support
- iDRAC supported
- Unified Server Configurator (UEFI 2.1) and UEFI shell support
- SMBIOS 2.5
- PCI-to-PCI bridge 1.0 compliant
- Dell Server Assistant 7.0 support
- System Service support
- Onboard PCI video BIOS support
- SATA enabled for CDROM and HDD
- PCI FW3.0 compliant
- I2O v1.5 ready
- Selectable boot support based on BIOS Boot Specification v1.01
- El Torito CD-ROM Boot 1.0
- Remote BIOS update support
- Remote Configuration Interface (RCI) support
- Console redirection through COM1
- PXE support based on Preboot Execution Environment Specification v2.1
- 2-byte ID support
- ePPID support in flash
- Memory remapping support
- AC recovery staggering power-up
- DIMM mismatch checking

The PowerEdge R415 BIOS does not support the following:

- BIOS language localization
- BIOS recovery after bad flash

## 8.2 Supported ACPI States

The following ACPI states are supported:

- ACPI compliance: S0, S4, S5
- NO S1, S2, S3 (STR)

State S4 is supported by OS support only.

## 8.3 Power Management Modes

### 8.3.1 Dell Active Power Controller

The Dell Active Power Controller (DAPC) is implemented in system BIOS and uses hardware level counters, etc., to determine hardware utilization. The BIOS uses this information to determine when to change the processor's operating frequency. The DAPC is OS independent and means that the OS no longer has control. This provides a consistent power management solution regardless of the installed OS. Some OS(s), particularly hypervisors, do not support power management, thus DAPC provides a solution when there otherwise would not be one.

### 8.3.2 Power Saving BIOS Setting (OS Control)

With the Power Saving BIOS setting, the OS monitors process/thread level utilization of the processor and uses processor controls to change the processor's operating frequency. For heavy workloads, the OS will run the processor at higher frequencies for additional performance. Lighter workloads do not need high performance, thus the OS will run the processor at lower frequencies.

### 8.3.3 Maximum Performance

The Maximum Performance mode disables power management. In this mode, the processor frequency is statically set to the highest supported frequency.

The power management features are implemented via two categories: fixed or generic.

Fixed features use bits defined in the ACPI specification for specific capabilities. The fixed-feature bits give the OS complete control over the power management of a device, since the location of the bits is given to the OS in the FACP table. Thus, a driver can directly access bits to control a device's power management.

Generic features have defined enable and status bits, but the functionality is not fully visible to the OS. Dell provides ASL code to handle the details of generic features, allowing the OS to intelligently communicate with system-specific hardware. Table 12 summarizes power management features, and Table 13 describes the possible power profiles.

**Table 12. BIOS Power Management Features**

| Feature          | Type  | Enable/Status/<br>Ctrl bit<br>location | Description   |
|------------------|-------|--|---|
| ACPI Mode Switch | Fixed | PCH                                    | The OS uses the SCI_EN bit to switch from legacy mode to ACPI mode.   |
| Sleep States     | Fixed | PCH                                    | Supported states: S0 (Working), S4-OS (Hibernation in Microsoft® Windows® 2000), and S5 (soft-off).<br>Not supported: S1 (standby or suspend) and S3. |
| Power Button     | Fixed | PCH                                    | In ACPI mode, OS has control of the power button. In non-   |

| Feature                 | Type    | Enable/Status/<br>Ctrl bit<br>location  | Description   |
|-------------------------|---------|---|---|
|                         |         |   | ACPI mode, SMI handler owns power button events.  |
| Real-Time Clock         | Fixed   | PCH                                     | The OS is able to configure the system to wake on the RTC alarm.  |
| Power Mgmt. Timer       | Fixed   | PCH                                     | 24-bit power management timer is used.  |
| Power Mgmt. Event (PME) | Generic | PCH                                     | Each host bus's PME# signal is routed to a separate general-purpose event pin in the chipset. When a device signals PME#, the system wakes (if necessary), the OS detects the event, and a Dell-defined ASL routine handles the event. Wake-on-LAN is one example of a PME. |
| USB Wake                | Generic | N/A                                     | This feature is not supported on this system since the S1 state is not supported.   |
| DBS                     | N/A     | Processor MSRs                          | This feature does P state transition under Microsoft® Windows®.   |
| C State Support         | N/A     | Processor and PCH registers             | This feature allows multiple C state supports for processor. This feature will work under Windows and ACPI OS that understand C states.   |
| Power Profile Support   | N/A     | Processor/IMC and PCH chipset registers | 11G Servers are the most energy-smart servers that Dell provides. In addition to P,C, and T states, BIOS exposes the power profiles to the OS. Each power profile has specific settings that fine tune processor, MCH, IOH, and Southbridge.                                |

**Table 13. BIOS Power Management Profiles**

| Profile                 | Description  |
|-------------------------|--|
| Maximum Performance     | DBPM Disabled (BIOS sets P-State to MAX)<br>Memory frequency: Maximum Performance<br>Fan algorithm: Maximum Performance                            |
| OS Control              | Enable OS DBPM Control (BIOS exposes all possible P states to OS)<br>Memory frequency: Maximum Performance<br>Fan algorithm: Minimum Power         |
| Active Power Controller | Enable Dell System DBPM (BIOS does not make all P states available to OS)<br>Memory frequency: Maximum Performance<br>Fan algorithm: Minimum Power |

| Profile             | Description   |
|---------------------|---|
| Maximum Performance | DBPM Disabled (BIOS sets P-State to MAX)<br>Memory frequency: Maximum Performance<br>Fan algorithm: Maximum Performance   |
| Custom              | CPU Power and Performance Management:<br>Maximum Performance, Minimum Power, OS<br>DBPM, System DBPM<br>Memory Power and Performance Management:<br>Maximum Performance, 1333MHz, 1067MHz,<br>800MHz, Minimum Power<br>Fan Algorithm: Maximum Performance, Minimum<br>Power |

## 9 Embedded NICs/LAN on Motherboard (LOM)

The Broadcom® 5716 LOM chip is located on the PowerEdge R415 motherboard. The 5716 chip is connected to the IOH via a PCI Express x4 gen2 link. The chip provides two 1xGB Ethernet ports with two RJ-45 connectors on the back of the system. The firmware for the LOM chip resides in a flash part. The PowerEdge R415 supports Wake-On-LAN (WOL) from either port.

## 10 I/O Slots

### 10.1 Overview

The PowerEdge R415 includes a total of two PCI Express expansion slots as follows:

- One x16 PCIe Gen2 slot for a full-height, full-length card (25W max)
- One x4 PCIe Gen1 slot for embedded SAS card only

The following requirements apply for the PCIe slots:

- Hot-plugging of PCIe cards is not supported.
- No other PCIe cards may be installed in the storage card slot, except for the dedicated SAS 6/iR modular card.

**Table 14. Supported Expansion Cards**

| Category             | Description                                | Width           | Slot Priority | Maximum Cards |
|----------------------|--|-----------------|---------------|---------------|
| Internal Controllers | Dell PERC H700-NVD                         | x8 Gen2         | 1             | 1             |
|                      | Dell PERC H700                             | x8 Gen2         | 1             | 1             |
|                      | Dell PERC H200                             | x8 Gen2         | 1             | 1             |
|                      | Dell PERC S300 Modular                     | x8 Gen2         | 2             | 1             |
|                      | SAS 6/iR Modular                           | x8 Gen1         | 2             | 1             |
| External Controllers | Dell 6Gbps SAS HBA                         | x8 Gen2         | 1             | 1             |
|                      | Dell PERC H700-512M-NVD                    | x8 Gen2         | 1             | 1             |
|                      | Dell PERC H700-1GB-NVD                     | x8 Gen2         | 1             | 1             |
|                      | Dell PERC H800-512M-NVD                    | x8 Gen2         | 1             | 1             |
|                      | Dell PERC H800-1GB-NVD                     | X8 Gen2         | 1             | 1             |
| FC8 Dual Port        | Qlogic® QLE2562 8Gbps FC HBA, Dual Port    | x8 Gen1/x4 Gen2 | 1             | 1             |
|                      | Emulex® LPe12002 8Gbps FC HBA, Dual Port   | x8 Gen1/x4 Gen2 | 1             | 1             |
|                      | Brocade® Dual-Port, 8 Gbps, PCIe           | X8 Gen 2        | 1             | 1             |
| FC8 Single Port      | Emulex® LPe12000 8Gbps FC HBA, Single Port | x8 Gen1/x4 Gen2 | 1             | 1             |
|                      | Qlogic® QLE2560 8Gbps FC HBA Single Port   | X8 Gen 2        | 1             | 1             |
|                      | Brocade® Single Port, 8Gbps, PCIe          | X8 Gen 2        | 1             | 1             |
| Fibre Channel        | Emulex® LPe11002 FC4 HBA, Dual Port        | x4 Gen1         | 1             | 1             |
|                      | Emulex® LPe1150 FC4 HBA, Single Port       | x4 Gen1         | 1             | 1             |
|                      | Qlogic® QLE220 FC4 HBA, Single Port        | x4 Gen1         | 1             | 1             |

| Category                  | Description  | Width           | Slot Priority | Maximum Cards |
|---------------------------|--|-----------------|---------------|---------------|
|                           | Qlogic® QLE2460 FC4 HBA, Single Port   | x4 Gen1         | 1             | 1             |
|                           | Qlogic® QLE2462 FC4 HBA, Dual Port   | x4 Gen1         | 1             | 1             |
|                           | Qlogic® QLE8152 8Gbps FC HBA, Dual Port  | x8 Gen1/x4 Gen2 | 1             | 1             |
| CNA                       | Qlogic® Dual Port 10GbE FCoE, SFP+   | X8 Gen 2        | 1             | 1             |
|                           | Emulex® Dual Port 10GbE, iSCSI, HBA, SFP+  | X8 Gen 2        | 1             | 1             |
| 10Gb Ethernet Controllers | 1020 Brocade® Dual Port 10G FCoE, SFP+, PCIe   | X8 Gen 2        | 1             | 1             |
|                           | Broadcom® 57712 Dual Port 10 G Base-T, PCIe  | X8 Gen2         | 1             | 1             |
|                           | Broadcom® NetXtreme™ II 57711 Dual-Port SFP+/Direct Attach 10GbE PCIe with TOE and iSCSI Offload | X8 Gen 2        | 1             | 1             |
|                           | Intel® Dual Port 10GE Base-T, PCIe Gen 2, Sr-IOV, FCoE   | X8 Gen 2        | 1             | 1             |
|                           | Intel® Ethernet X520 DA2 Dual-Port 10Gb Server Adapter   | X8 Gen 2        | 1             | 1             |
|                           | Intel® X520-T2 Dual-Port 10GbE Server Adapter  | X8 Gen 2        | 1             | 1             |
|                           | Emulex® OCE10102FXD, 10G PCIe FCoE CAN, Dual Port  | X8 Gen 2        | 1             | 1             |
| 1G NICs                   | Intel® PCIe Quad Port Copper   | x4 Gen1/Gen2    | 1             | 1             |
|                           | Intel® PRO/1000PT 1G Cu Single Port NIC  | x1 Gen1         | 1             | 1             |
|                           | Broadcom® 5709 IPv6 1G Cu Dual Port NIC TOE  | x4 Gen1         | 1             | 1             |
|                           | Broadcom® 5709 IPV6 1G CU Dual Port NIC TOE/iSOE   | x4 Gen1         | 1             | 1             |
|                           | Intel® PCIe Dual Port Copper   | x4 Gen1/Gen2    | 1             | 1             |
|                           | Broadcom® 5709 Quad Port, LP & FH bracket, ToE, iSoE   | X4 Gen2         | 1             | 1             |

For more information on PCIe cards, see Expansion Cards and Expansion-Card Risers in the Installing System Components chapter in the *PowerEdge R415 Hardware Owner's Manual* on [Support.Dell.com](http://Support.Dell.com).

## 10.2 Boot Order

The boot order can be customized based on bootable devices detected by the BIOS.

## 10.3 NICs

See details in the table above.

## 10.4 NIC and LOM Enumeration

LOMs will enumerate first in order to have consistent Ethernet assignment (i.e., eth0). NIC enumeration varies depending on configuration.

## 10.5 PCI Card Dimensions

For information about PCI slots and card dimensions, see the Back-Panel Features and Indicators section in the About Your System chapter in the *PowerEdge R415 Hardware Owner's Manual* on [Support.Dell.com](https://support.dell.com).



# 11 Storage

## 11.1 Overview

The PowerEdge R415 supports up to four hard drives in one of the following configurations:

- 4 x 3.5" cabled SATA from motherboard SATA connector
- 4 x 3.5" cabled SAS or SATA with add-on storage controller
- 4 x 3.5" hot-swap SAS or SATA with add-on storage controller
- 4 x 2.5" hot-swap SAS or SATA or SSD with add-on storage controller

The 2.5" hard drive requires a hot-plug configuration with the 3.5" hard drive carrier and retention kit. After a chassis configuration is chosen (cabled or hot-plug) there is not an available upgrade option. See Table 15.

**Table 15. Supported Hard Drives**

| Form Factor | Capacity                      | Speed | Type    | Cabled or Hot-plug                    |
|-------------|-------------------------------|-------|---------|---------------------------------------|
| 3.5"        | 160GB, 250GB, 500GB, 1TB, 2TB | 7.2K  | SATA    | Both                                  |
| 3.5"        | 500GB, 1TB, 2TB               | 7.2K  | NL SAS  | 1TB: cabled only                      |
| 3.5"        | 146GB                         | 15K   | SAS 3GB | Both                                  |
| 3.5"        | 300GB, 450GB, 600GB           | 15K   | SAS 6GB | Both                                  |
| 2.5"        | 146GB, 300GB, 600GB           | 10K   | SAS     | All: hot-plug only (with HDD carrier) |
| 2.5"        | 50GB                          | N/A   | SSD     | Both                                  |

## 11.2 RAID Configurations

Table 16 details RAID configurations for the PowerEdge R415.

**Table 16. RAID Configurations**

| Factory Configuration |                     |         |          |  | Non-Mixed drives<br>all SATA, all SAS, or<br>all SSD; all 2.5" or all<br>3.5" |         |
|-----------------------|---------------------|---------|----------|--|---|---------|
| Cabled/<br>Hot Plug   | Config Type         | Configs |          | Description  | Min HDD   | Max HDD |
| Cabled                | Embedded<br>SATA    | C1      | MSTCBL   | On-board SATA controller (AMD SR5670)                                  | 1   | 4       |
| Cabled                | SAS/SATA<br>No RAID | C2      | ASSCBL   | Add-in SAS/SATA RAID card, no RAID (SAS 6/iR or PERC H200)             | 1   | 4       |
| Cabled                | SAS/SATA<br>RAID    | C3      | ASSR0CBL | Add-in SAS/SATA RAID card, RAID 0 (SAS 6/iR or PERC H200 or PERC H700) | 1   | 4       |
|                       |                     | C4      | ASSR1CBL | Add-in SAS/SATA RAID card, RAID 1 (SAS 6/iR or PERC H200 or PERC H700) | 2   | 2       |

| Factory Configuration                        |                                    |         |           |   | Non-Mixed drives<br>all SATA, all SAS, or<br>all SSD; all 2.5" or all<br>3.5"   |                       |
|--|------------------------------------|---------|-----------|---|---|-----------------------|
| Cabled/<br>Hot Plug                          | Config Type                        | Configs |           | Description   | Min HDD   | Max HDD               |
|  |                                    | C5      | ASSR5CBL  | Add-in SAS/SATA RAID card, RAID 5 (PERC H700)                                   | 3   | 4                     |
|  |                                    | C6      | ASSR6CBL  | Add-in SAS/SATA RAID card, RAID 6 (PERC H700)                                   | 4   | 4                     |
|  |                                    | C7      | ASSR10CBL | Add-in SAS/SATA RAID card, RAID 10 (PERC H200 or H700)                          | 4   | 4                     |
|  |                                    | C8      | ASSR5CBL  | Add-in SAS/SATA RAID card, RAID 5 (PERC S300)                                   | 3   | 4                     |
|  |                                    | C9      | ASSR10CBL | Add-in SAS/SATA RAID card, RAID 10 (PERC S300)                                  | 4   | 4                     |
| Cabled/<br>Hot Plug                          | Config Type                        | Configs |           | Description   | Min HDD   | Max HDD               |
| Hot Plug                                     | SAS/SATA/SSD<br>No RAID            | C10     | ASS       | Add-in SAS/SATA RAID card, No RAID (SAS 6/iR or PERC H200)                      | 1   | 4                     |
| Hot Plug                                     | SAS/SATA/SSD<br>RAID               | C11     | ASSR0     | Add-in SAS/SATA RAID card, RAID 0 (SAS 6/iR or PERC H200 or PERC H700)          | 1   | 4                     |
|  |                                    | C12     | ASSR1     | Add-in SAS/SATA RAID card, RAID 1 (SAS 6/iR or PERC H200 or PERC H700)          | 2   | 2                     |
|  |                                    | C13     | ASSR5     | Add-in SAS/SATA RAID card, RAID 5 (PERC H700)                                   | 3   | 4                     |
|  |                                    | C14     | ASSR6     | Add-in SAS/SATA RAID card, RAID 6 (PERC H700)                                   | 4   | 4                     |
|  |                                    | C15     | ASSR10    | Add-in SAS/SATA RAID card, RAID 10 (PERC H200 or H700)                          | 4   | 4                     |
| Hot Plug                                     | SAS/SATA<br>RAID                   | C16     | ASSR5     | Add-in SAS/SATA RAID card, RAID 5 (PERC S300)                                   | 3   | 4                     |
|  |                                    | C17     | ASSR10    | Add-in SAS/SATA RAID card, RAID 10 (PERC S300)                                  | 4   | 4                     |
| Hot Plug                                     | SAS/SATA/SSD<br>RAID 1 + RAID<br>1 | C18     | ASSR1R1   | Add-in SAS/SATA/RAID card, RAID 1 + RAID 1 (SAS 6/iR or PERC H200 or PERC H700) | 2+2   | 2+2                   |
| Mixed HDD (SAS + SATA) Factory Configuration |                                    |         |           |   | Mixed SAS + SATA<br>Min: 2xSAS+1xSATA<br>Max: 2xSAS+2xSATA;<br>all 2.5" or 3.5" |                       |
| Hot Plug                                     | Mix SAS and<br>SATA<br>No RAID     | C19     | ASS-X     | Add-in SAS/SATA RAID card, no RAID (SAS 6/iR or PERC H200)                      | 2 x SAS +<br>1 x SATA   | 2 x SAS +<br>1 x SATA |

| Factory Configuration |                             |         |           | Non-Mixed drives<br>all SATA, all SAS, or<br>all SSD; all 2.5" or all<br>3.5"         |                       |                       |
|-----------------------|-----------------------------|---------|-----------|---|-----------------------|-----------------------|
| Cabled/<br>Hot Plug   | Config Type                 | Configs |           | Description   | Min HDD               | Max HDD               |
| Hot Plug              | Mix SAS and<br>SATA<br>RAID | C20     | ASSR1R1-X | Add-in SAS/SATA/RAID card, RAID 1 +<br>RAID 1 (SAS 6/iR or PERC H200 or PERC<br>H700) | 2 x SAS +<br>2 x SATA | 2 x SAS +<br>2 x SATA |

Additional restrictions for RAID configurations are as follows:

- SSD support requires H200 or H700. SAS 6i/R and PERC S300 do not support SSD.
- Hard drives must be all 2.5" or 3.5".

PERC S300 does not support the following virtualization solutions:

- Microsoft® Hyper-V™ server 2008 x64 (download version)
- Microsoft® Windows Server® 2008 x64 (Hyper-V™ role enabled)
- Microsoft® Windows Server® 2008 SP2 x64 (Hyper-V™ role enabled)
- Microsoft® Windows Server® 2008 R2 (Microsoft® Windows® 7 includes SP2 bits) x64 (Hyper-V™ role enabled)

PERC S300 does not support Linux® operating systems or VMware® virtualization software.

## 11.3 Persistent Storage

The PowerEdge R415 offers two types of persistent storage: unmanaged and managed. The following options are available for persistent storage:

- Unmanaged internal SD module
- Managed iDRAC6 Express or Enterprise (optional)

## 11.4 Internal SD Module (Unmanaged Internal Persistent Storage)

The internal SD module Unmanaged Internal Persistent Storage (UIPS) consists of two ports:

- One port on the control panel board for the USB key
- One port on the internal SD module for the SD card

The UIPS is a feature which enables the following solutions:

- USB license keys used for software application enablement
- User custom-boot OS and pre-boot OS
  - Loaded into memory and then run (used for ease of deployment, as well as in diskless environments, such as HPCC)
  - User custom logs/scratch pad (user-defined information, removable and portable after system is down)

## 11.5 LED Indicators

Each disk drive carrier has two LED indicators visible from the front of the system. One is a green LED for disk activity and the other is a bicolor (green/amber) LED for status information. The activity LED is driven by the disk drive during normal operation. The bicolor LED is controlled by the SEP device on the backplane. Both LEDs are used to indicate certain conditions under direction of a storage controller.

For more information, see the Hard-Drive Indicator Patterns section in the About Your System chapter in the *PowerEdge R415 Hardware Owner's Manual* on [Support.Dell.com](http://support.dell.com).

## 11.6 Optical Drives

The PowerEdge R415 supports one SATA interface, DVD-ROM or DVD+/-RW.

## 11.7 Tape Drives

External tape drives and tape libraries are supported. No internal tape drive support is available.

For more information on supported tape drives and tape libraries, see <http://www.dell.com/storage>.

## 11.8 External Storage

External storage devices are supported. For more information, see <http://www.dell.com/storage>.

## 12 Video

The PowerEdge R415 is equipped with a Matrox® G200eW with 8 MB memory integrated in the Nuvoton® WPCM450 (BMC controller). Supported resolutions are listed in Table 17.

**Table 17. Graphics Video Modes**

| Resolution  | Refresh Rate (Hz) | Color Depth (bit) |
|---|-------------------|-------------------|
| 640 x 480   | 60, 72, 75, 85    | 8, 16, 32         |
| 800 x 600   | 60, 72, 75, 85    | 8, 16, 32         |
| 1024 x 768  | 60, 72, 75, 85    | 8, 16, 32         |
| 1152 x 864  | 75                | 8, 16, 32         |
| 1280 x 1024 <sup>1</sup>  | 60                | 32                |
| 1280 x 1024 <sup>2</sup>  | 60, 75, 85        | 8, 16             |
| <sup>1</sup> 32 bit color only supported at 60Hz for this resolution.<br><sup>2</sup> 85Hz for KVM and 1600x1200 at 60Hz for video out. |                   |                   |

## 13 Rack Information

### 13.1 Overview

The ReadyRails™ sliding and static rail systems for the R415 provide tool-less support for 4-post racks with square or unthreaded round mounting holes including all generations of Dell racks. Both support tooled mounting in 4-post threaded racks (an optional adapter brackets kit is required for the sliding rails), with the static rails also providing tooled mounting support for 2-post (Telco) racks for added versatility. The optional cable management arm (CMA) can be mounted on either the left or right side of the sliding rails without the use of tools for fast and easy deployment.

**Note:** The PowerEdge R415 is not compatible with any other Dell rails including previous generation rails, but it does use the same sliding rails as the R310 and R410 and uses the same static rails as the R210, R310, and R410.

### 13.2 Rails

The rail offerings for the R415 consist of two types: sliding rails and static rails.

#### 13.2.1 Sliding Rails

Sliding rails allow the system to be fully extended out of the rack for service, and are available with or without the optional cable management arm (CMA). See Figure 18.

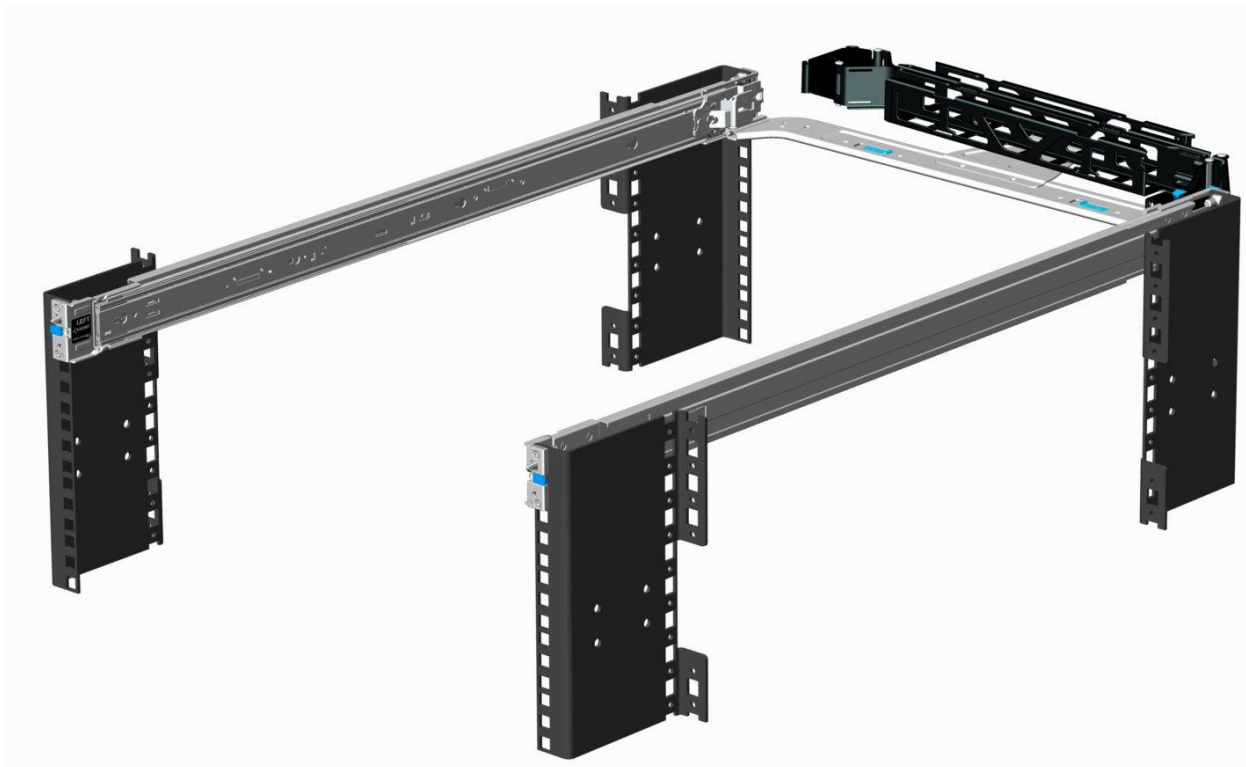

Figure 18. R415 Sliding Rails with Optional CMA

Sliding rail kits can be used in a threaded hole rack only if threaded rack adapter brackets are installed. The threaded rack adapter brackets are first mounted to the EIA flanges in the rack, and then the sliding rails

Dell

are mounted into the brackets. The design of the brackets has been optimized to limit the forward shift of the system in the rack to only 17.3 mm.

The adapter brackets kit includes six brackets to accommodate different rail lengths, plus four sets of custom screws in common thread sizes. See Figure 19. A detailed Getting Started Guide is included in the kit along with directions for installing the brackets and mounting the rails into the brackets.

Depending on the depth of the rack used, it may be necessary to remove the server's bezel in order to close the door of the rack. A minimum of 58 mm will be needed between the back surface of the door panel and the front face of the EIA flange for the front door to close with the 11G server bezel installed.



**Figure 19. 1U Threaded Rack Adapter Brackets Kit**

### 13.2.2 Static Rails

Static rails support a wider variety of racks than the sliding rails, but do not support serviceability in the rack and are thus not compatible with the CMA. See Figure 20.

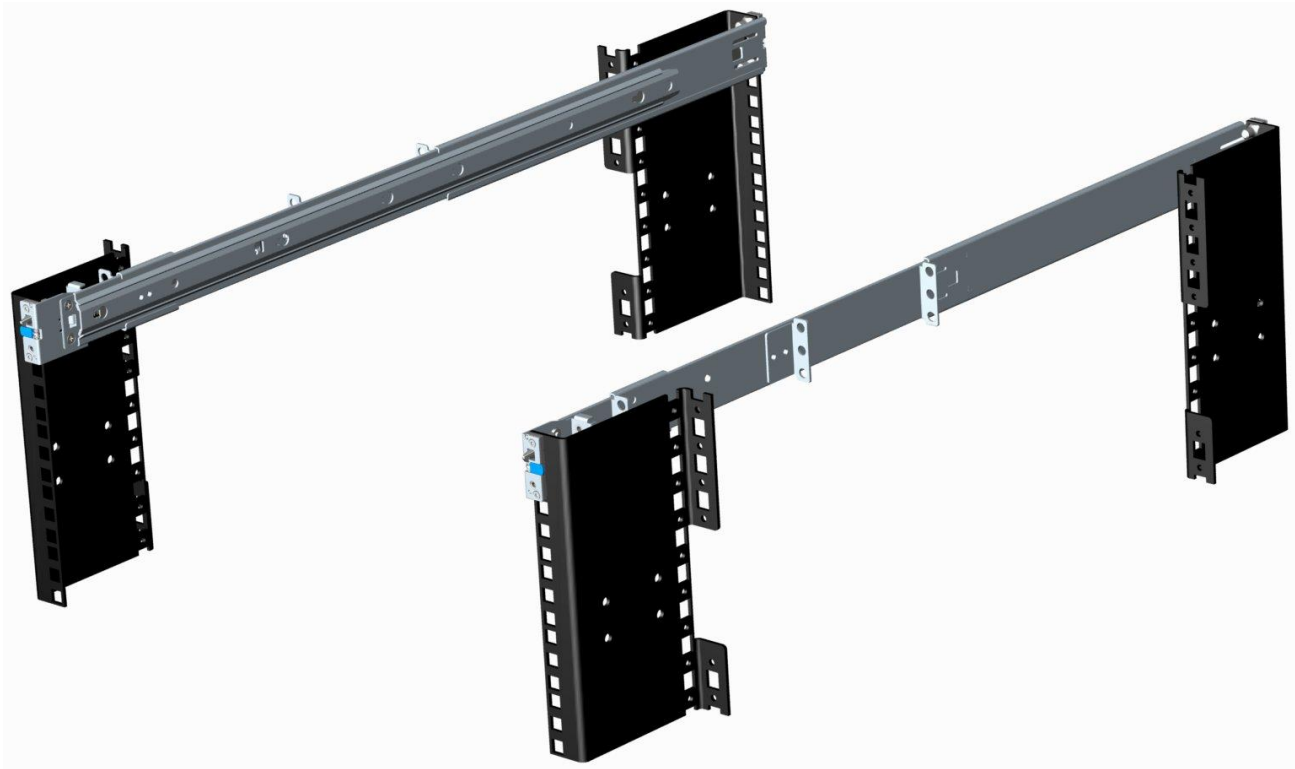

**Figure 20. R415 Static Rails**

One key factor in selecting the proper rails is identifying the type of rack in which they will be installed. Both the sliding rails and the static rails support mounting in 19”-wide, EIA-310-E compliant 4-post racks, but only the static rails support mounting in 2-post (Telco) racks.

Table 18 provides a summary of the rack types supported by the R415 rails.

**Table 18. Supported Racks**

| Product | Rail ID | Mounting Interface | Rail Type | Rack Types Supported |       |        |        |        |
|---------|---------|--------------------|-----------|----------------------|-------|--------|--------|--------|
|         |         |                    |           | 4-Post               |       |        | 2-Post |        |
|         |         |                    |           | Square               | Round | Thread | Flush  | Center |
| R415    | A3      | ReadyRails         | Sliding   | ✓                    | ✓     | ✓*     | ✗      | ✗      |
|         | A4      | ReadyRails/Generic | Static    | ✓                    | ✓     | ✓      | ✓      | ✓      |

\*Requires the 1U Threaded Rack Adapter Brackets Kit (Dell PN 8Y19G)

Screws are not included in the static rail kit since the threaded racks are offered with a variety of thread designations. Users must provide their own screws when mounting the static rails in threaded or 2-post racks.

Other factors to consider in rail selection include the spacing between the front and rear mounting flanges of the rack, the type and location of any equipment mounted in the back of the rack such as power distribution units (PDUs), and the overall depth of the rack. See Table 19.

Due to their reduced complexity and lack of need for CMA support, the static rails offer a greater adjustability range and an overall smaller footprint than the sliding rails.



**Table 19. Rail Adjustability Ranges and Depth**

| Product | Rail ID | Mounting Interface     | Rail Type | Rail Adjustability Range (mm) |     |       |     |          |     | Rail Depth (mm) |          |
|---------|---------|------------------------|-----------|-------------------------------|-----|-------|-----|----------|-----|-----------------|----------|
|         |         |                        |           | Square                        |     | Round |     | Threaded |     | without CMA     | with CMA |
|         |         |                        |           | Min                           | Max | Min   | Max | Min      | Max |                 |          |
| R415    | A3      | ReadyRails             | Sliding   | 686                           | 883 | 672   | 876 | 651      | 897 | 714             | 835      |
|         | A4      | ReadyRails/<br>Generic | Static    | 608                           | 879 | 594   | 872 | 604      | 890 | 622             | N/A      |

The adjustment range of the rails is a function of the type of rack in which they are being mounted. The min-max values listed above represent the allowable distance between the front and rear mounting flanges in the rack. Rail depth represents the minimum depth of the rail as measured from the rack front mounting flanges when the rail rear bracket is positioned all the way forward.

### 13.3 Cable Management Arm (CMA)

The optional cable management arm (CMA) for the R415 organizes and secures the cords and cables exiting the back of the server and unfolds to allow the server to extend out of the rack without having to detach the cables. Some key features of the R415 CMA include:

- Large U-shaped baskets support dense cable loads.
- An open-vent pattern allows optimal airflow.
- The CMA mounting is fully-reversible (can be mounted on either side) with no conversion required.
- Hook-and-loop straps are used (rather than plastic tie wraps) to eliminate the risk of cable damage during cycling.
- A low-profile fixed tray is included to support and retain the CMA in its fully-closed position.
- The CMA and the tray can be mounted without the use of tools using simple and intuitive snap-in designs.

## 14 Operating Systems and Virtualization

For detailed information, see the following:

- [Operating System Support Matrix for Dell PowerEdge Systems](#) on [www.Dell.com](http://www.Dell.com)
- *Dell PowerEdge R415 Systems Getting Started With Your System* guide on [Support.Dell.com](http://Support.Dell.com)

## 15 Systems Management

### 15.1 Overview/Description

Dell aims on delivering open, flexible, and integrated solutions that help you reduce the complexity of managing disparate IT assets by building comprehensive IT management solutions. Combining Dell PowerEdge Servers with a wide selection of Dell-developed management solutions gives you choice and flexibility, so you can simplify and save in environments of any size. To help you meet your server performance demands, Dell offers Dell OpenManage™ systems management solutions for:

- Deployment of one or many servers from a single console
- Monitoring of server and storage health and maintenance
- Update of system, operating system, and application software

Dell offers IT management solutions for organizations of all sizes—priced, sized, and supported right.

### 15.2 Server Management

A Dell Systems Management and Documentation DVD and a Dell Management Console DVD are included with the product. ISO images are also available. A brief description of available content:

- **Dell Systems Build and Update Utility:** Dell Systems Build and Update Utility assists in OS install and pre-OS hardware configuration and updates.
- **OpenManage Server Administrator:** The OpenManage Server Administrator (OMSA) tool provides a comprehensive, one-to-one systems management solution, designed for system administrators to manage systems locally and remotely on a network. OMSA allows system administrators to focus on managing their entire network by providing comprehensive one-to-one systems management.
- **Management Console:** Our legacy IT Assistant console is also included, as well as tools to allow access to our remote management products. These tools are Remote Access Service, for iDRAC, and the BMC Management Utility.
- **Active Directory Snap-in Utility:** The Active Directory Snap-in Utility provides an extension snap-in to the Microsoft Active Directory. This allows you to manage Dell specific Active Directory objects. The Dell-specific schema class definitions and their installation are also included on the DVD.
- **Dell Systems Service Diagnostics Tools:** Dell Systems Service and Diagnostics tools deliver the latest Dell optimized drivers, utilities, and operating system-based diagnostics that you can use to update your system.
- **eDocs:** The section includes PDF files for PowerEdge systems, storage peripheral, and OpenManage software.
- **Dell Management Console DVD:** The Dell Management Console is a Web-based systems management software that enables you to discover and inventory devices on your network. It also provides advanced functions, such as health and performance monitoring of networked devices and patch management capabilities for Dell systems.
- **Server Update Utility:** In addition to the Systems Management Tools and Documentation and Dell Management Console DVDs, customers have the option to obtain Server Update Utility DVD. This DVD has an inventory tool for managing updates to firmware, BIOS and drivers for either Linux or Windows varieties.

### 15.3 Embedded Server Management

The PowerEdge R415 implements circuitry for the next generation of Embedded Server Management. It is Intelligent Platform Management Interface (IPMI) v2.0 compliant. The optional iDRAC (Integrated Dell

Dell

Remote Access Controller) is responsible for acting as an interface between the host system and its management software and the peripheral devices. These peripheral devices consist of the PSUs, the storage backplane, integrated SAS HBA or PERC 6/I, and control panel with display.

The optional upgrade to iDRAC6 provides features for managing the server remotely or in data center lights-out environments.

Advanced iDRAC features require the installation of the optional iDRAC6 Enterprise card.

## 15.4 Lifecycle Controller and Unified Server Configurator

Embedded management is comprised of several interdependent pieces:

- Lifecycle Controller
- Unified Server Configurator
- iDRAC6
- vFlash

Lifecycle controller powers the embedded management features. It is integrated and tamperproof storage for system-management tools and enablement utilities (firmware, drivers, etc.). It is flash partitioned to support multiple, future-use cases.

Dell Unified Server Configurator (USC) is a local 1:1 graphical user interface embedded on Lifecycle Controller that aids in local server provisioning in a pre-OS environment. For servers with iDRAC Express, the Lifecycle Controller offers OS install, platform updates, platform configuration, and diagnostics capabilities. For servers without iDRAC Express, this utility has limited functionality and offers OS install and diagnostics capabilities only.

To access the Unified Server Configurator, press the <F10> key within 10 seconds of the Dell logo's appearance during the system boot process. Current functionality enabled by the Unified Server Configurator includes:

**Table 20. Unified Server Configurator Features and Description**

| Feature                           | Description  |
|-----------------------------------|--|
| Faster O/S Installation           | Drivers and the installation utility are embedded on system, so no need to scour DELL.COM  |
| Faster System Updates             | Integration with Dell support automatically directed to latest versions of the Unified Server Configurator, iDRAC, RAID, BIOS, NIC, and Power Supply   |
| Update Rollback                   | Ability to recover to previous "known good state" for all updatable components   |
| More Comprehensive Diagnostics    | Diagnostic utilities are embedded on system  |
| Simplified Hardware Configuration | Detects RAID controller and allows user to configure virtual disk and choose virtual disk as boot device, eliminating the need to launch a separate utility. Also provides configuration for iDRAC, BIOS, and NIC/LOM. |

## 15.5 iDRAC Express

The optional iDRAC Express is the first tier of iDRAC6 upgrades. In addition to upgrading the system with a Lifecycle Controller, the iDRAC6 Express offers the following key features:

## Dell

- Graphical web interface
- Standard-based interfaces
- Server Sensor monitoring and fault alerting
- Secure operation of remote access functions including authentication, authorization, and encryption
- Power control and management with the ability to limit server power consumption and remotely control server power states
- Advanced troubleshooting capabilities

For more information on iDRAC6 Express features see Table 21.

## 15.6 iDRAC6 Enterprise

The optional iDRAC6 Enterprise card provides access to advanced iDRAC6 features. The iDRAC6 Enterprise connects directly to the R415 planar and is mounted parallel to the planar with stand-offs.

Key features for the iDRAC6 Enterprise include:

- Scripting capability with Dell’s Racadm command-line
- Remote video, keyboard, and mouse control with Virtual Console
- Remote media access with Virtual Media
- Dedicated network interface

Additionally, the iDRAC6 Enterprise can be upgraded by adding the vFlash Media card. This is a 1 GB Dell branded SD card that enables a persistent 256 MB virtual flash partition. In the future, vFlash will be expanded to include additional features.

A more detailed feature list for iDRAC6 Enterprise and vFlash is included in Table 21.

**Table 21. Features List for BMC, iDRAC, and vFlash**

| Feature                                | BMC | iDRAC6 Express | iDRAC6 Enterprise | vFlash Media |
|--|-----|----------------|-------------------|--------------|
| <b>Interface and Standards Support</b> |     |                |                   |              |
| IPMI 2.0                               | ✓   | ✓              | ✓                 | ✓            |
| Web-based GUI                          |     | ✓              | ✓                 | ✓            |
| SNMP                                   |     | ✓              | ✓                 | ✓            |
| WSMAN                                  |     | ✓              | ✓                 | ✓            |
| SMASH-CLP                              |     | ✓              | ✓                 | ✓            |
| Racadm command-line                    |     |                | ✓                 | ✓            |
| <b>Conductivity</b>                    |     |                |                   |              |
| Shared/Failover Network Modes          | ✓   | ✓              | ✓                 | ✓            |
| IPv4                                   | ✓   | ✓              | ✓                 | ✓            |
| VLAN Tagging                           | ✓   | ✓              | ✓                 | ✓            |
| IPv6                                   |     | ✓              | ✓                 | ✓            |
| Dynamic DNS                            | ✓   | ✓              | ✓                 | ✓            |
| Dedicated NIC                          |     |                | ✓                 | ✓            |

Dell

| Feature                                  | BMC | iDRAC6 Express | iDRAC6 Enterprise | vFlash Media |
|--|-----|----------------|-------------------|--------------|
| <b>Security and Authentication</b>       |     |                |                   |              |
| Role-based Authority                     | ✓   | ✓              | ✓                 | ✓            |
| Local Users                              | ✓   | ✓              | ✓                 | ✓            |
| Active Directory                         |     | ✓              | ✓                 | ✓            |
| SSL Encryption                           |     | ✓              | ✓                 | ✓            |
| <b>Remote Management and Remediation</b> |     |                |                   |              |
| Remote Firmware Update                   | ✓   | ✓              | ✓                 | ✓            |
| Server power control                     | ✓   | ✓              | ✓                 | ✓            |
| Serial-over-LAN (with proxy)             | ✓   | ✓              | ✓                 | ✓            |
| Serial-over-LAN (no proxy)               |     | ✓              | ✓                 | ✓            |
| Power capping                            |     | ✓              | ✓                 | ✓            |
| Last crash screen capture                |     | ✓              | ✓                 | ✓            |
| Boot capture                             |     | ✓              | ✓                 | ✓            |
| Serial-over-LAN                          |     | ✓              | ✓                 | ✓            |
| Virtual media                            |     |                | ✓                 | ✓            |
| Virtual console                          |     |                | ✓                 | ✓            |
| Virtual console sharing                  |     |                | ✓                 | ✓            |
| Virtual flash                            |     |                |                   | ✓            |
| <b>Monitoring</b>                        |     |                |                   |              |
| Sensor Monitoring and Alerting           | ✓   | ✓              | ✓                 | ✓            |
| Real-time Power Monitoring*              | ✓   | ✓              | ✓                 | ✓            |
| Real-time Power Graphing*                | ✓   | ✓              | ✓                 | ✓            |
| Historical Power Counters*               | ✓   | ✓              | ✓                 | ✓            |
| <b>Logging Features</b>                  |     |                |                   |              |
| System Event Log                         | ✓   | ✓              | ✓                 | ✓            |
| RAC Log                                  |     | ✓              | ✓                 | ✓            |
| Trace Log                                |     |                | ✓                 | ✓            |

## 16 USB Peripherals

The PowerEdge R415 supports the following USB devices:

- USB key (bootable)
- Keyboard (only one USB keyboard is supported)
- Mouse (only one USB mouse is supported)
- Optional USB DVD-ROM

## Appendix A. Statement of Volatility

The Dell PowerEdge R415 contains both volatile and non-volatile (NV) components. Volatile components lose their data immediately upon removal of power from the component. Non-volatile components continue to retain their data even after the power has been removed from the component. Components chosen as user-definable configuration options (those not soldered to the motherboard) are not included in the Statement of Volatility. Configuration option information (pertinent to options such as microprocessors, system memory, remote access controllers, and storage controllers) is available by component separately. The NV components detailed in Table 22 are present in the PowerEdge R415 server.

**Table 22. R415 Volatility Table**

| Server BIOS Memory  | Details   |
|---|---|
| Size:   | 32Mbit  |
| Type [e.g., Flash PROM, EEPROM]:  | Flash EEPROM  |
| Can user programs or operating system write data to it during normal operation? | No  |
| Purpose? [e.g., boot code]  | Boot Code and Configuration Information   |
| How is data input to this memory?   | Loading flash memory requires a vendor provided firmware file and loader program which is executed by booting up the system from a floppy or OS based executable containing the firmware file and the loader. System loaded with arbitrary data in firmware memory would not operate. |
| How is this memory write protected?   | Software write protected  |
| Server CMOS (Complementary Metal-Oxide Semiconductor) Memory                    | Details   |
| Size:   | 512 bytes   |
| Type: [e.g., Flash PROM, EEPROM]:   | Battery backed NVRAM  |
| Can user programs or operating system write data to it during normal operation? | No  |
| Purpose? [e.g., boot code]  | RTC and configuration settings  |
| How is data input to this memory?   | F2 Setup Menu during POST   |
| How is this memory write protected?   | N/A   |
| Remarks   | Jumper on motherboard can be used to clear to factory default settings  |



| <b>LOM (LAN [Network Interface] on Motherboard) Memory</b>                      | <b>Details</b>   |
|---|--|
| Size:   | 4Mb (1MB)  |
| Type: [e.g., Flash PROM, EEPROM]:   | Flash  |
| Can user programs or operating system write data to it during normal operation? | Yes, under software control  |
| Purpose? [e.g., boot code]  | Contains LOM boot code and config data   |
| How is data input to this memory?   | Requires vendor provided firmware file and loader program used during factory assembly or possible field update. A system loaded with arbitrary data in firmware memory would not operate. |
| How is this memory write protected?   | Software control   |
| <b>Server System FRU</b>  | <b>Details</b>   |
| Size:   | 4KB  |
| Type: [e.g., Flash PROM, EEPROM]:   | SEEPROM  |
| Can user programs or operating system write data to it during normal operation? | No   |
| Purpose? [e.g., boot code]  | Store System FRU   |
| How is data input to this memory?   | BMC controller write   |
| How is this memory write protected?   | Not write protected  |
| <b>Power Supply FRU</b>   | <b>Details</b>   |
| Size:   | 256 bytes  |
| Type: [e.g., Flash PROM, EEPROM]:   | SEEPROM  |
| Can user programs or operating system write data to it during normal operation? | No   |
| Purpose? [e.g., boot code]  | Store power supply information   |
| How is data input to this memory?   | Programmed by the power supply manufacturer.   |
| How is this memory write protected?   | Not write protected  |

|  |   |
|--|---|
| <b>TPM (Trusted Platform Module;<br/>For boards shipped outside of China; Boards<br/>sold to destinations in China do not have TPM<br/>at this time)</b> | <b>Details</b>  |
| Size:  | Unspecified size of user ROM, RAM, EEPROM;<br>128 bytes of OTP memory included  |
| Type: [e.g., Flash PROM, EEPROM]:  | ROM, RAM, EEPROM  |
| Can user programs or operating system write<br>data to it during normal operation?   | Yes, operating systems and applications that<br>conform to the TCG standard can write data to<br>the TPM during normal operation. Access to the<br>NV Storage is controlled by the TPM owner.   |
| Purpose? [e.g., boot code]   | Trusted Platform Module NV storage. May be<br>used to securely storage of encryption keys.  |
| How is data input to this memory?  | TCG TPM Specification defined command<br>interface or Using TPM Enabled operating<br>systems  |
| How is this memory write protected?  | As defined by the TCG TPM Specification,<br>protection of this NV memory area is<br>configurable by the TPM owner.  |
| <b>Backplane Firmware and FRU</b>  | <b>Details</b>  |
| Size:  | 32KB  |
| Type: [e.g., Flash PROM, EEPROM]:  | Flash   |
| Can user programs or operating system write<br>data to it during normal operation?   | No  |
| Purpose? [e.g., boot code]   | Backplane Firmware and FRU data storage   |
| How is data input to this memory?  | Loading flash memory requires a vendor<br>provided firmware file and loader program<br>which is executed by booting up the system<br>from a floppy or OS based executable<br>containing the firmware file and the loader.<br>System loaded with arbitrary data in firmware<br>memory would not operate. |
| <b>Embedded Bootable Memory Device</b>   | <b>Details</b>  |
| Size:  | 1GB   |
| Type: [e.g., Flash PROM, EEPROM]:  | MMC   |
| Can user programs or operating system write<br>data to it during normal operation?   | Yes   |
| Purpose? [e.g., boot code]   | Optional embedded boot device   |
| How is data input to this memory?  | Factory installed or via USB bus  |
| How is this memory write protected?  | Not write protected   |

| Server BMC (Baseboard Management Controller) Firmware Flash Memory              | Details   |
|---|---|
| Size:   | 16MB Flash  |
| Type: [e.g., Flash PROM, EEPROM]:   | SPI Flash   |
| Can user programs or operating system write data to it during normal operation? | No  |
| Purpose? [e.g., boot code]  | Stores the BMC Firmware   |
| How is data input to this memory?   | Loading flash memory requires a vendor provided firmware file and loader program which is executed by booting up the system from a floppy or OS based executable containing the firmware file and the loader. System loaded with arbitrary data in firmware memory would not operate. |
| How is this memory write protected?   | Software write protected  |

To obtain optional component information, please refer to the Dell Statement of Volatility for the individual components. Please direct any questions to your Dell Marketing contact.

## Appendix B. Certifications

### B.1 Regulatory Certifications

Regulatory model: E07S

Regulatory Type: E07S003

Regulatory compliance information can be located at the following sites:

- [Product Safety, EMC and Environmental Datasheets](#)
- [Dell Regulatory Compliance Home Page](#)

### B.2 Product Safety Certifications

The product has been certified and bears the Mark, as applicable, of the Product Safety authorities as indicated in Table 23.

**Table 23. Product Safety Certifications**

| Country/Region | Authority or Mark             |
|----------------|-------------------------------|
| Argentina      | IRAM                          |
| Belarus        | BELLIS                        |
| Canada         | SCC                           |
| China          | CNCA or CCC                   |
| Croatia        | KONCAR                        |
| European Union | CE                            |
| Germany        | TUV                           |
| IECEE          | IECEE CB                      |
| Israel         | SII                           |
| Kazakhstan     | OTAN - CKT                    |
| Kenya          | KEBS                          |
| Kuwait         | KUCAS                         |
| Mexico         | NYCE or NOM                   |
| Moldova        | INSM                          |
| Nigeria        | SONCAP                        |
| Norway         | NEMKO                         |
| Russia         | GOST                          |
| Saudi Arabia   | KSA ICCP                      |
| South Africa   | NRCS                          |
| Taiwan         | BSMI                          |
| Ukraine        | UKRTEST or<br>UKRSERTCOMPUTER |
| United States  | NRTL                          |
| Uzbekistan     | STZ                           |

### B.3 Electromagnetic Compatibility

The product has been certified and bears the Mark, as applicable, of the EMC authorities as indicated in Table 24.

**Table 24. Electromagnetic Compatibility Certifications**

| Country/Region                           | Authority or Mark          | Class   |
|--|----------------------------|---------|
| Australia/New Zealand                    | ACMA or C-Tick             | Class A |
| Belarus                                  | BELLIS                     | Class A |
| Bosnia & Herzegovina, Montenegro, Serbia | KVALITET                   | Class A |
| Canada                                   | ICES                       | Class A |
| China                                    | CNCA or CCC                | Class A |
| Croatia                                  | KONCAR                     | Class A |
| European Union                           | CE                         | Class A |
| Israel                                   | SII                        | Class A |
| Japan                                    | VCCI                       | Class A |
| Kazakhstan                               | OTAN - CKT                 | Class A |
| Moldova                                  | INSM                       | Class A |
| Norway                                   | NEMKO                      | Class A |
| Russia                                   | GOST                       | Class A |
| South Africa                             | SABS                       | Class A |
| South Korea                              | KCC                        | Class A |
| Taiwan                                   | BSMI                       | Class A |
| Ukraine                                  | UKRTEST or UKRSERTCOMPUTER | Class A |
| United States                            | FCC                        | Class A |
| Uzbekistan                               | STZ                        | Class A |
| Vietnam                                  | ICT                        | Class A |

### B.4 Ergonomics, Acoustics and Hygienics

The product has been certified and bears the Mark, as applicable, of the Ergonomics, Acoustics, and Hygienics authorities as indicated in Table 25.

**Table 25. Ergonomics, Acoustics and Hygienics**

| Country/Region | Authority or Mark |
|----------------|-------------------|
| Belarus        | BELLIS            |
| Germany        | GS                |
| Russia         | GOST              |

## Appendix C. Additional Information and Options

The PowerEdge R415 system conforms to the industry standards detailed in Table 26.

**Table 26. Industry Standards**

| Standard  | URL for information and specifications  |
|---|---|
| <b>ACPI</b><br>Advance Configuration and Power Interface Specification, v2.0c     | <a href="http://www.acpi.info/">http://www.acpi.info/</a>   |
| <b>Energy Star</b><br>EPA Version 1.0 of the Computer Server specification        | <a href="http://www.energystar.gov/index.cfm?c=archives.enterprise_servers">http://www.energystar.gov/index.cfm?c=archives.enterprise_servers</a>         |
| <b>Ethernet</b><br>IEEE 802.3-2005  | <a href="http://standards.ieee.org/getieee802/802.3.html">http://standards.ieee.org/getieee802/802.3.html</a>   |
| <b>IPMI</b><br>Intelligent Platform Management Interface, v2.0                    | <a href="http://www.intel.com/design/servers/ipmi/">http://www.intel.com/design/servers/ipmi/</a>   |
| <b>DDR3 Memory</b><br>DDR3 SDRAM Specification, Rev. 3A                           | <a href="http://www.jedec.org/download/search/JESD79-3A.pdf">http://www.jedec.org/download/search/JESD79-3A.pdf</a>                                       |
| <b>LPC</b><br>Low Pin Count Interface Specification, Rev. 1.1                     | <a href="http://developer.AMD.com/design/chipsets/industry/lpc.htm">http://developer.AMD.com/design/chipsets/industry/lpc.htm</a>                         |
| <b>PCI Express</b><br>PCI Express Base Specification Rev. 2.0                     | <a href="http://www.pcisig.com/specifications/pciexpress/">http://www.pcisig.com/specifications/pciexpress/</a>   |
| <b>PMBus</b><br>Power System Management Protocol Specification, v1.1              | <a href="http://pmbus.info/specs.html">http://pmbus.info/specs.html</a>   |
| <b>SAS</b><br>Serial Attached SCSI, v1.1  | <a href="http://www.t10.org/cgi-bin/ac.pl?t=f&amp;f=sas1r10.pdf">http://www.t10.org/cgi-bin/ac.pl?t=f&amp;f=sas1r10.pdf</a>                               |
| <b>SATA</b><br>Serial ATA Rev. 2.6;<br>SATA II, Extensions to SATA 1.0a, Rev. 1.2 | <a href="http://sata-io.org/">http://sata-io.org/</a>   |
| <b>SMBIOS</b><br>System Management BIOS Reference Specification, v2.6             | <a href="http://www.dmtf.org/standards/smbios/">http://www.dmtf.org/standards/smbios/</a>   |
| <b>TPM</b><br>Trusted Platform Module Specification, v1.2                         | <a href="http://www.trustedcomputinggroup.org/resources/tpm_main_specification">http://www.trustedcomputinggroup.org/resources/tpm_main_specification</a> |
| <b>UEFI</b>   | <a href="http://www.uefi.org/specs/">http://www.uefi.org/specs/</a>   |

| Standard  | URL for information and specifications  |
|---|---|
| Unified Extensible Firmware Interface Specification, v2.1                         |   |
| <b>USB</b><br>Universal Serial Bus Specification, Rev. 2.0                        | <a href="http://www.usb.org/developers/docs/">http://www.usb.org/developers/docs/</a>   |
| <b>Windows Logo</b><br>Windows Logo Program System and Device Requirements, v3.10 | <a href="http://www.microsoft.com/whdc/winlogo/hwrequirements.msp">http://www.microsoft.com/whdc/winlogo/hwrequirements.msp</a> |