



NEXGEN FIXED OUTRIGGERS

KNOW BEFORE YOU GO

Store as a Complete & Assembled Kit ✓

NEXGen Fixed Outriggers should always be stored as a complete and assembled kit as shown below:



They are not designed to be left on a bi ski when not in use. Storing NEXGen Fixed Outriggers as a complete and assembled kit has benefits that outweigh the time savings of other practices.

Those benefits are:

- Users must install the U-Bolt. This helps educate what it is, why it is important, and how NEXGen Fixed Outriggers are different from other offerings.
- Users must check that all wing nuts are tight while installing. This eliminates assuming they are tight and causing damage to equipment.
- Hardware cannot get lost if it is stored and assembled with the fixed outriggers. This eliminates inconveniencing the next user or inferior hardware being used in its place.

Never cut the U-Bolt Leash. It ensures proper setup. Leaving a U-Bolt on every bi ski is not recommended. This practice does not sufficiently educate users of the U-Bolts presence or ensure that users check that hardware is tight.

Set up the Rigger Mount ✓

The Rigger Mount¹ & U-Bolt System³ allow NEXGen Fixed Outriggers to be used with both the Dynamique and Bi-Unique Bi Ski.

The Rigger Mount¹ attaches to the Articulating Mechanism, a shared feature of both bi skis.

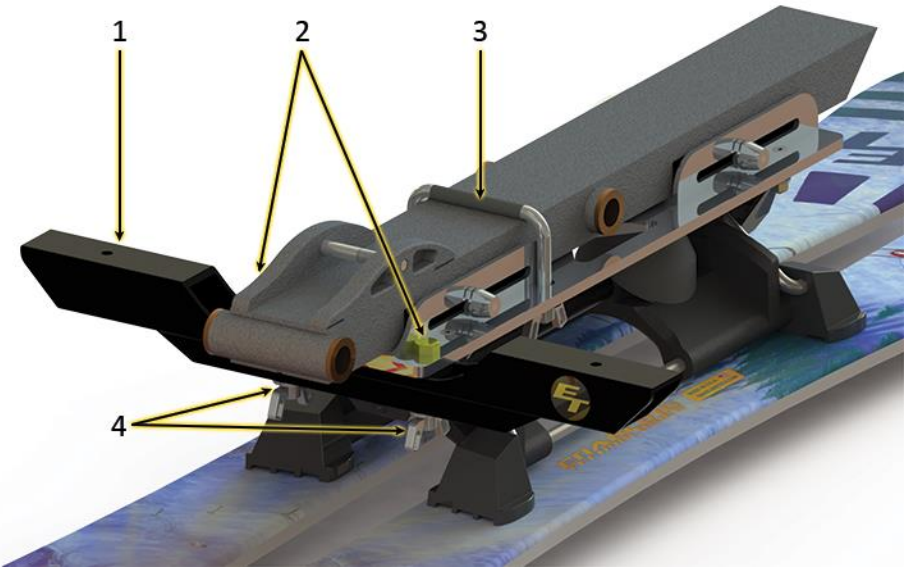

To install:

- 1) Slide the two 5/16 hex bolts² into the holes at the front of the Mechanism Plate and push the Rigger Mount¹ onto the bolts.
- 2) Secure the Rigger Mount¹ to the Mechanism Plate using the provided washers and nylock wing nuts⁴.

While skiing:

Periodically check that the wing nuts⁴ are tight.

The Rigger Mount¹ and U-Bolt System³ are not designed to be left on the bi ski when not in use. The ends of the Rigger Mount can dig into the snow. This can cause the ski to flip, injure the skier, and bend the Rigger Mount.

Install the appropriate U-Bolt ✓

Mounting NEXGen Fixed Outriggers to the Articulating Mechanism ensures the best skiing performance regardless of the skier's center of mass position. Unfortunately though, it means the frame must be secured to the Articulating Mechanism. This is done with a U-Bolt. Every NEXGen Fixed Outrigger set comes with two U-Bolts:

- Short U-Bolt = Dynamique or Junior Bi-Unique (one Main Rail thick)
- Long U-Bolt = Adult / XL Bi-Unique (two Main Rails thick)

To install:

- 1) Adjust the skier's center of mass to the ideal fore-aft ski position.
- 2) Push the appropriate length U-Bolt over the Main Rail and through the mounting holes (as shown on the previous page). The legs of the U-Bolt may need to be pulled out slightly to clear the Front Channel.
- 3) Slide the U-Bolt Spacer Plate onto the underside of the U-Bolt. The U-Bolt Spacer Plate is leashed to the Rigger Mount.
- 4) Secure the U-Bolt with the provided washers and nylock wing nuts.

While skiing:

Periodically check that the wing nuts are tight. If you need to adjust the skier's center of mass, loosen the U-Bolt, reposition the ski fore-aft, and then retighten.



The photo above shows catastrophic damage to the Articulating Mechanism Channels from skiing NEXGen Fixed Outriggers without the U-Bolt.

Use appropriately ✓

NEXGen Fixed Outriggers are not designed for all terrain.

They are designed for groomed novice terrain. Their use must constantly be evaluated based on a skier's ability level, the terrain, and tetherer's skill level.

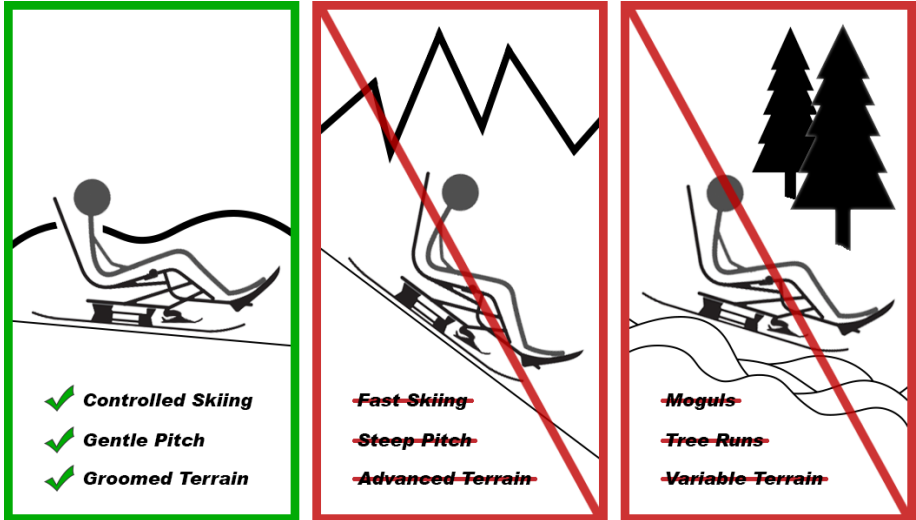

Extreme caution is necessary when using NEXGen Fixed Outriggers on powder or soft spring days. The Rigger Ends can dig into soft snow, injure the skier, and break equipment. Instructors must evaluate the snow conditions and their ability level to decide if it is safe to use NEXGen Fixed Outriggers on such days.

The spring loaded tips significantly reduce side to side flop, but it means extra mindfulness must be used when navigating the slopes. Never ski backwards or falling leaf with the spring loaded tips. Be aware to leave adequate room when stopping near the trail edge so that pulling backwards isn't necessary to start skiing again.

Set Rigger Ends to the appropriate width ✓

- Wide = Lower ability skiers, wide terrain, novice tetherers
- Narrow = Higher ability skiers, narrow terrain, advanced tetherers

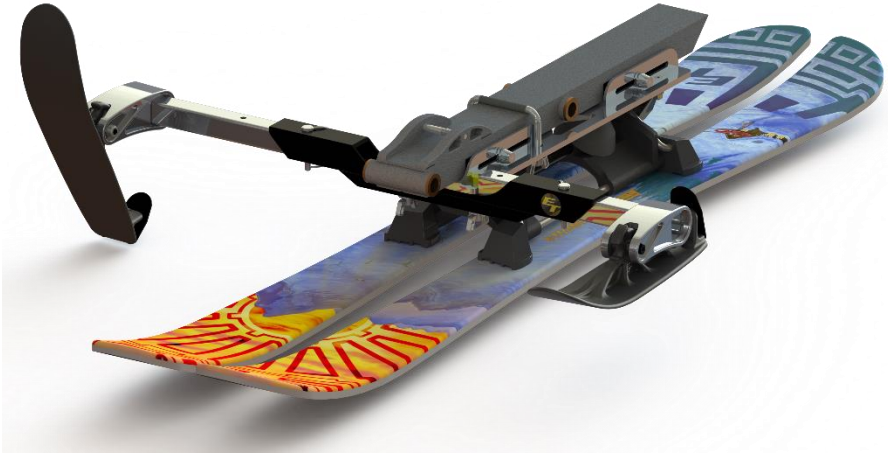

To install:

- 1) Slide the Rigger Ends into the Rigger Mount.
- 2) Align to the desired width and insert a snap pin through the Rigger Mount and the Rigger End.

If the Rigger Tube does not easily slide into the Rigger Mount do not force it. Inspect for ice buildup or burs and remove as necessary.

Remove or store the Rigger Ends when loading the chairlift ✓

Remove the Left and Right Rigger Ends from the Rigger Mount before loading the chairlift.



To store the Rigger Ends (if desired):

- 1) Remove the Left and Right Riggers.
- 2) Rotate the Riggers 90 Degrees and re-insert them into the Rigger Mount.
- 3) Secure the snap pin in the innermost holes of the Rigger Ends between the gaps in the Rigger Mount.

Loading a chairlift with the Rigger Ends in the ski position is an unnecessary risk. The spring loaded tips can be cumbersome and cause you to mis-load the chairlift. More importantly, fixed outriggers limit the turning radius of the ski. When you unload the chairlift, you may need the full turning abilities of the bi ski to avoid injuring skiers that have fallen and did not clear the unloading zone.

**ENABLING
TECHNOLOGIES**

enablingtech.com

Enabling Technologies // 303.578.9345
2200 S Jason St Denver, CO 80223
info@enablingtech.com