

RAKU WALL LIGHT | PRODUCT SPECIFICATIONS



mayclay | ONE OF ONE



BEHIND THE LIGHTING

Every unique ceramic piece is handcrafted with intention and love. Individually made to order in Hannah's home ceramic studio, this project was a collaborative effort between Hannah, MayClay, and husband Greg, a commercial electrician and owner of Grid Electrical Contractors. This means the highest standards have been maintained throughout the process of designing, custom building and testing these hand-crafted wall lights. This unique and rustic approach to lighting design translates into a timeless architectural piece celebrating its subtle raw materials.

mayclay

PRODUCT SPECIFICATIONS



NAME: Stone Raku
DESIGN: MayClay Ceramics
MATERIAL: White Raku Clay
TYPE: Interior Wall Light

DIAMETER: 110mm
HEIGHT: 180mm
WEIGHT: 1.4 kg

LIGHT: Recommended 240 VOLT - LED GU10 Globe 5-7W dimmable.

CASE HOUSING: Matt Finish PC and ABS custom injection mould. UV stable, high impact strength and thermal resistant 107mm L x 37mm W x 28mm D

WALL FIXING PLATE: Aluminium custom laser cut 103mm L x 32mm W x 2mm D



All fittings are wheel thrown with slight dimensional and shape inconsistencies to be expected due to the organic creative process. Fired twice with a final glaze firing of 1280 degrees celsius ensuring this bespoke fittings durability and longevity.

mayclay

PRODUCT SPECIFICATIONS

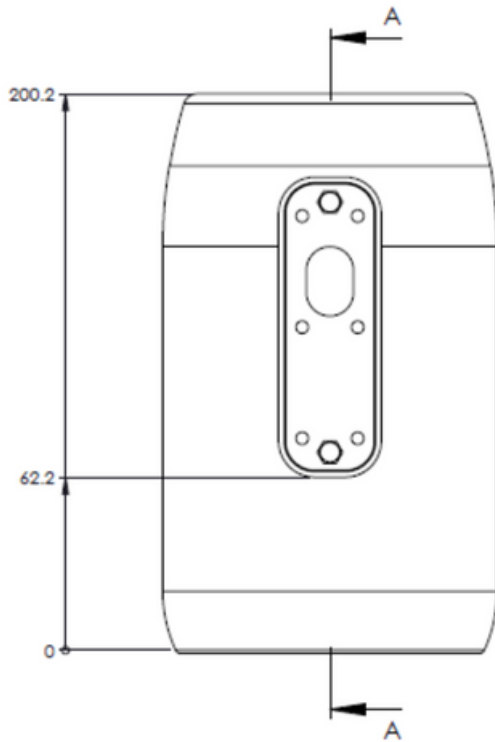

VIEW OF WALL
FIXING PLATE
FROM THE BACK

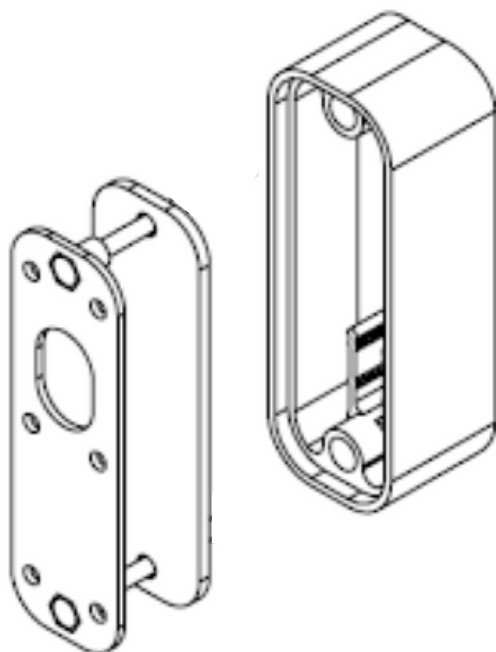

VIEW OF WALL
FIXING PLATE
COMPONENTS



KEEP CONNECTED @MAYCLAY_CERAMICS