

SRAM **i-MOTION 3**

user manual

betriebsanleitung

notice d'utilisation

handleiding

brugsanvisning

bruksanvisning

SRAM

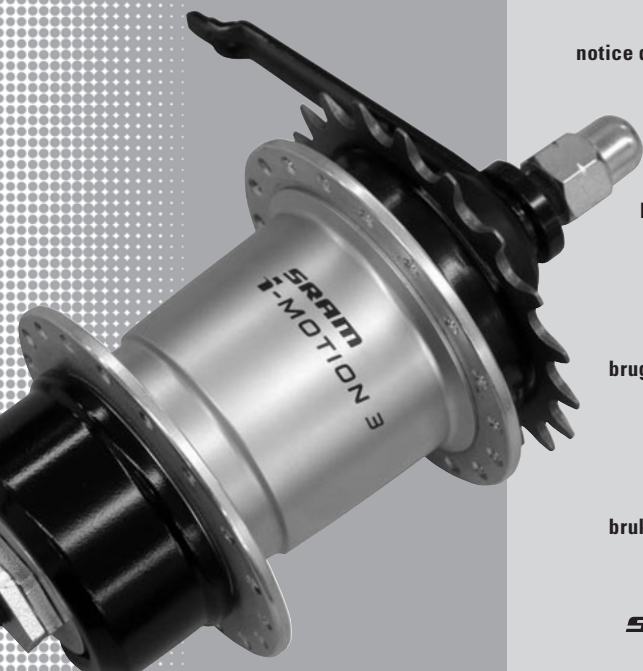

These instructions contain important information about your SRAM i-MOTION 3 System.

Please take the time to read these operating instructions carefully.

Your SRAM i-MOTION 3 System is almost maintenance-free. Should you have any queries that are not answered in these operating instructions, your qualified bicycle specialist will be pleased to help you.

Have a nice time and enjoy your SRAM i-MOTION 3.

Please note:



Precautionary measures, which protect from possible accident, injury or danger to life, or which prevent possible damage to the bicycle.



Special advice to assist in the better handling of the operation, control, and adjustment procedures.

© Copyright SRAM Corporation 2006

Publ. No. 5300 E/D/F/NI/Dk/Sv

Information may be enhanced without prior notice.

Released June 2006

SRAM Technical Documentation,
Schweinfurt/Germany

TABLE OF CONTENTS

E

THE SRAM i-MOTION 3 SYSTEM	4
-----------------------------------	----------

OPERATION	5
------------------	----------

MAINTENANCE AND CARE

» Gear adjustment	6
-------------------	---

» Remove and fit rear wheel	7
-----------------------------	---

» Cleaning and lubrication	10
----------------------------	----

» Repair work / wear parts	11
----------------------------	----

ASSEMBLY OF COMPONENTS	12
-------------------------------	-----------

TECHNICAL DATA	18
-----------------------	-----------

THE SRAM i-MOTION 3 SYSTEM

A modern bicycle derailleur should be sporty, load shiftable, intuitive to use and durable! With the new i-MOTION 3, SRAM delivers an internal gear hub that meets and exceeds all these requirements!



i-MOTION 3 gear hub

Load shiftable. Light shifting forces. Shifting during standstill is possible: Easy re-start e.g. at a traffic light.



i-MOTION 3 shifter

Intuitive gear indication, high-quality design.



i-MOTION 3 connecting link

Easy wheel removal: The gear adjustment remains unchanged.

OPERATION

SHIFTING

1 Shift gears by turning the rotating grip.

- » You can shift while standing still or while riding your bicycle.
- » When approaching inclines shift down in good time.
- » The smoothest and fastest gear change happens when changing gears while pedaling with low force.

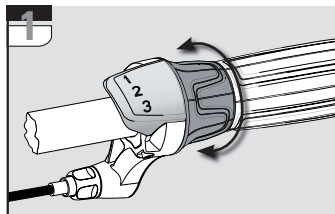

BRAKING

On long and steep downhill roads, simultaneously use rear and front brakes to avoid heating up of the brakes.

 Excessive heating of the hub with the back pedal brake may result in loss of lubricant and braking too hard. This will lead to a trip to the repair shop.

 Read the applicable user manual for each bicycle equipped with i-BRAKE or band brakes.

MAINTENANCE AND CARE

GEAR ADJUSTMENT

2 Shift the twist shifter to the 3rd gear.

 The shift cable must be without play in 3rd gear. That means it must be pulled out of the hub as far as it will go.

3 While pulling the plastic retainer (1), it should not be possible to pull the shift cable further out of the hub.

– Shift cable has too much play:
Shift the twist shifter to the 1st gear.

4 Reduce play of the shift cable by turning the barrel adjuster (2) at the shifter.

– Shift cable is too taut:
The shifter won't shift into 3rd gear or the hub doesn't shift in 1st gear or will permanently switch between 1st and 2nd gear.
Shift the twist shifter to the 1st gear.

4 Decrease shift cable tension by turning the barrel adjuster (2) at the shifter.

» Shift the twist shifter to the 3rd gear and check again, until there isn't any play in the shift cable.

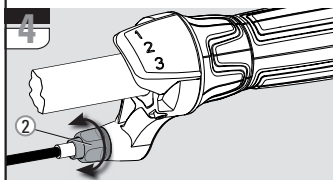
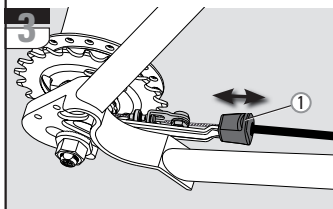
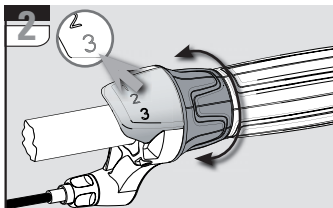

MAINTENANCE AND CARE

REMOVE AND FIT REAR WHEEL

REMOVING THE REAR WHEEL

5 Shift the twist shifter to the 1st gear.

6 Pull the plastic retainer (1) off the cable stop bracket (2).

7 Disconnect the shift cable by disengaging the link (3) of the cable nipple (4).

8 Loosen the axle nuts (5) and remove the nuts and the retaining washers (6) underneath them.
If applicable, unscrew the frame clamp connection (7) of the brake lever.

» Remove the rear wheel.

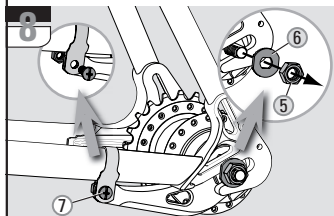
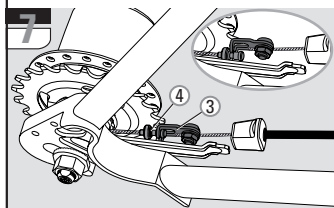
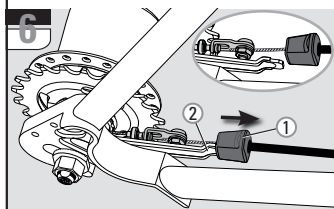
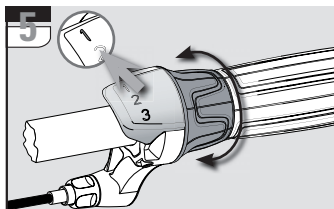

MAINTENANCE AND CARE

REMOVE AND FIT REAR WHEEL

FITTING THE REAR WHEEL

» Place the rear wheel into the rear frame.

9 Slide one retaining washer each (1) onto each axle end. The serrations of the retaining washer must bear against the dropout of the frame.

10 Align the cable stop bracket (2) parallel to the frame stay (3).

11 Mount the axle nuts (4) and tighten them alternately with a torque of 30 – 40 Nm (266 – 350 in.lbs.).

12 If applicable, mount the brake lever (5) between the two straps of the frame clamp (6).

 The frame clamp must be seated on the frame with no play. Use only self-locking nuts! Tightening torque: 2 – 3 Nm (18 – 27 in.lbs.).

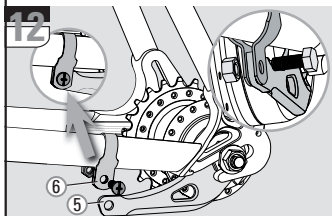
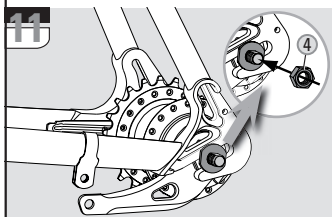
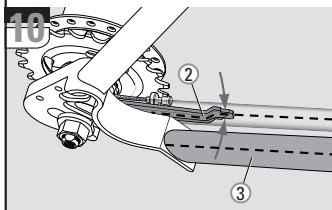
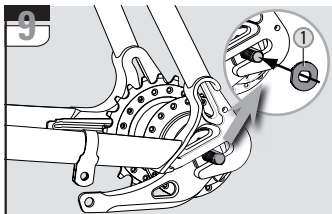

MAINTENANCE AND CARE

REMOVE AND FIT REAR WHEEL

13 Make sure that the shifter is set to the 1st gear.

14 Make the cable connection by hooking in the link (7) of the shift cable to the cable nipple (8) on the hub.

15 Slide the plastic retainer (9) completely onto the cable stop bracket (10).

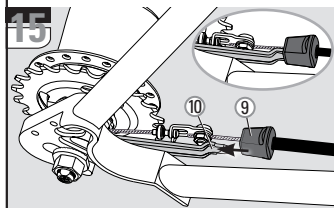
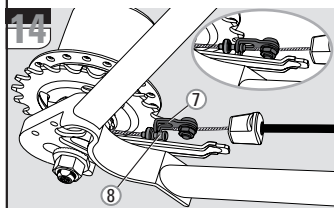
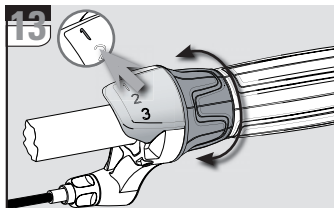

MAINTENANCE AND CARE CLEANING AND LUBRICATION

CLEANING

- » Your SRAM i-MOTION 3 components are well protected from external environmental impacts. However, do not use water under pressure (such as pressure washers or water jets) for cleaning to prevent malfunctions due to water penetration.
- » During the winter season, you should clean your bicycle in shorter intervals so that winter road salt cannot cause any damage.
- » Do not use aggressive cleaners.
- » Clean dirty chains before oiling. Let cleaner set for only a few minutes and rinse with water. Do not oil chain until completely dry.



LUBRICATION

- » The rear wheel hub is provided with permanent lubrication and maintenance-free under normal conditions.
- » Regular lubrication will extend the chain's service life.

MAINTENANCE AND CARE

REPAIR WORK / WEAR PARTS

REPAIR WORK



Only a qualified bike dealer should perform any necessary work on the gear hub, shifter, and brakes.

- » Unauthorized work on your i-MOTION 3 system could endanger you and your warranty may become void.
- » Please contact your qualified bike dealer regarding any questions or problem you may have.

Back pedal brake

If the back pedal brake is braking too hard, the brake jacket has to be lubricated with special grease. This work must be performed by a qualified bike dealer.

Cable Change

If a cable must be replaced (shifter cable or brake cable), contact your qualified dealer.

WEAR PARTS

Brake liners or brake jackets, brake cables, shift cables, handlebar grips, sprockets, and bike chains are wear parts. Please check these parts regularly and replace them timely.

E

ASSEMBLY OF COMPONENTS

ASSEMBLY HUB

» Spoke the hub as normal.

16 Set the dust cover (1) onto the driver. The curve must point to the outside.

17 Set the sprocket (2) onto the driver.

If an offset sprocket will be used, mount the sprocket with the curve pointing to the outside.

18 Mount the sprocket retaining ring (3) onto the driver. Check proper seat of the retaining ring.

19 Slide the cable stop bracket (4) onto the axle end of the sprocket side. Thereafter mount the washer with rubber insert (5) to fix the the cable stop bracket.

» Place the rear wheel into the rear frame.

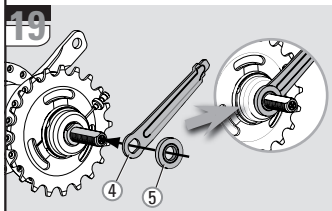
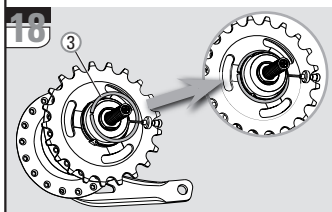
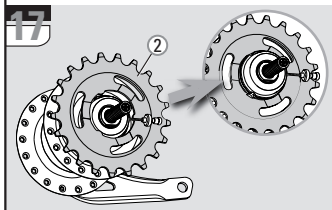
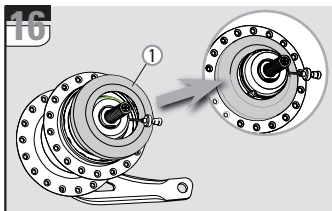

ASSEMBLY OF COMPONENTS

- 20** Slide one retaining washer each (6) onto each axle end. The serrations of the retaining washer must bear against the dropout of the frame.

- 21** Align the cable stop bracket (7) parallel to the frame stay (8).

- 22** Mount the axle nuts (9) and tighten them alternately with a torque of 30 – 40 Nm (266 – 350 in.lbs.).

- 23** If applicable, mount the brake lever (10) between the two straps of the frame clamp (11).



The frame clamp must be seated on the frame without play. Use only self-locking nuts! Tightening torque: 2 – 3 Nm (18 – 27 in.lbs.).

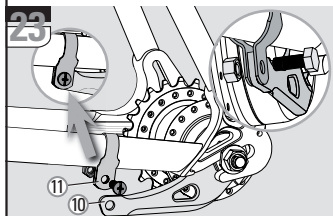
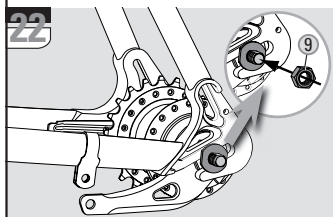
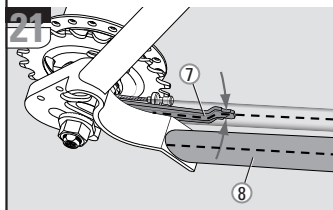
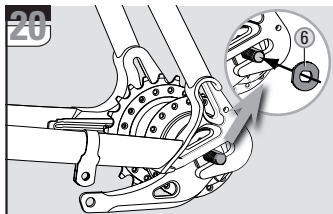

ASSEMBLY OF COMPONENTS

ASSEMBLY SHIFTER

24 Slide the shifter (1) onto the handlebar.

25 Slide the handlebar grip (2) onto the handlebar.

26 Align the shifter on the handlebar grip and position the shifter according to your needs. Tighten the clamp bolt (3).
2.5 mm Allen wrench, torque 1.7 Nm (15 in.lbs.).

! Never use lubricants or solvents to install handlebar grips. Handlebar grips provide an axial safety function and may not become separated from the handlebar.

- » Make sure that the shifter and brake lever function properly and are unobstructed (re-adjust if needed).
- » Never ride without the handlebar grips. The turning grip of the twist shifter could become loose. This can result in severe injury.

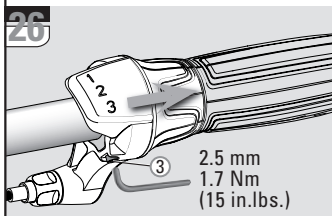
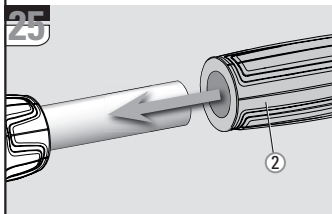
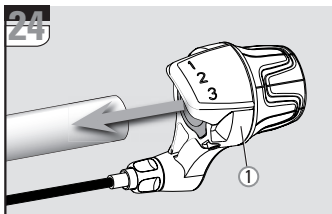

ASSEMBLY OF COMPONENTS

ASSEMBLY SHIFT CABLE

-  Make sure that the cable housing length is sufficient to allow an extreme turning angle.
- » Also consider the influence of adjustable handlebars and stems on the cable housing length.

- 27** Fasten the cable housing on the frame.

-  The cable housing must be movable at the fastening points.
- » Avoid tight bends when installing the shift cable.

- 28** Make sure that the shifter is set to the 1st gear.

- 29** Make the cable connection by hooking in the link (1) of the shift cable to the cable nipple (2) on the hub.

- 30** Slide the plastic retainer (3) completely onto the cable stop bracket (4).

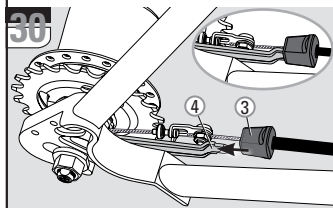
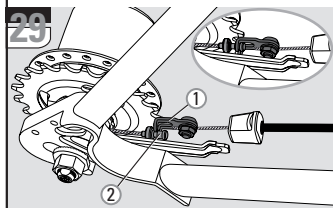
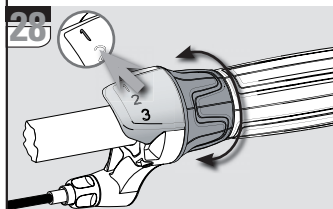

ASSEMBLY OF COMPONENTS

GEAR ADJUSTMENT

» Shift the gears up and down repeatedly before setting the shifter so that the shift cable can settle.

31 Shift the twist shifter to the 3rd gear.

 The shift cable must be without play in 3rd gear. That means it must be pulled out of the hub as far as it will go.

32 While pulling the plastic retainer (1), it should not be possible to pull the shift cable further out of the hub.

– Shift cable has too much play:
Shift the twist shifter to the 1st gear.

33 Reduce play of the shift cable by turning the barrel adjuster (2) at the shifter.

– Shift cable is too taut:
The shifter won't shift into 3rd gear or the hub doesn't shift in 1st gear or will permanently switch between 1st and 2nd gear.
Shift the twist shifter to the 1st gear.

33 Decrease shift cable tension by turning the barrel adjuster (2) at the shifter.

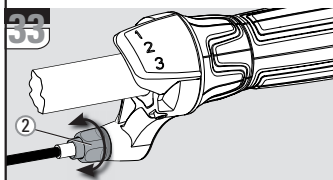
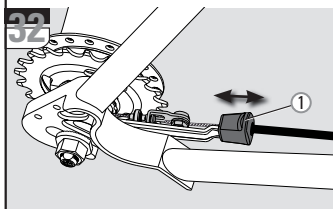
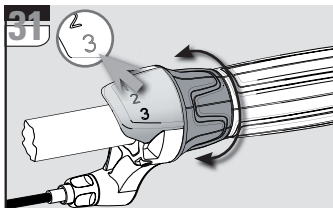

» Shift the twist shifter to the 3rd gear and check again, until there isn't any play in the shift cable.

ASSEMBLY OF COMPONENTS

E

TECHNICAL DATA

GEAR HUB

i-MOTION 3 with back pedal brake

	Speeds	3
	Brake	With back pedal brake
	Over Locknut Dim., OLD	130 mm
Axle	Length, L	168 and 178 mm
	Ends Diameter	M 10x1
	Dropout Width Dim., A	min. 4 mm / max. 8 mm
Spoke	Holes	28 / 32 / 36
	Hole Diameter	3.0 mm
	Hole Ref. \varnothing, HR	70 mm
	Flange Dist. to $\frac{1}{2}$ OLD	$F_1 = 27.3 \text{ mm}$ / $F_2 = 27.6 \text{ mm}$
	Total Ratio	186 %
	Gear jump 1 to 3	36% / 36%
Chain	Chainline, CL	44.0 mm (straight spr.) / 40.5 mm (off-set spr.)
	Dimension	$\frac{1}{2}'' \times \frac{1}{8}''$ and $\frac{1}{2}'' \times \frac{3}{32}''$
Compat- ibility	Sprocket	16/17/18 T. (straight) / 19/20/21 T. (off-set)
	Shifter	SRAM i-MOTION 3
	Tandem	not suitable for tandems and transport bicycles

SHIFTER

i-MOTION 3 shifter

	Shifter type	Twist shifter
	Assembly location	Right side of handlebar
	Gear indication	Window
	Barrel adjuster	Indexed
	Clamp diameter	22.3 mm
	Straight handlebar ends	Length = min. 150 mm
	Cable laying	Continuous cable housing (pre-assembled)

TECHNICAL DATA

E

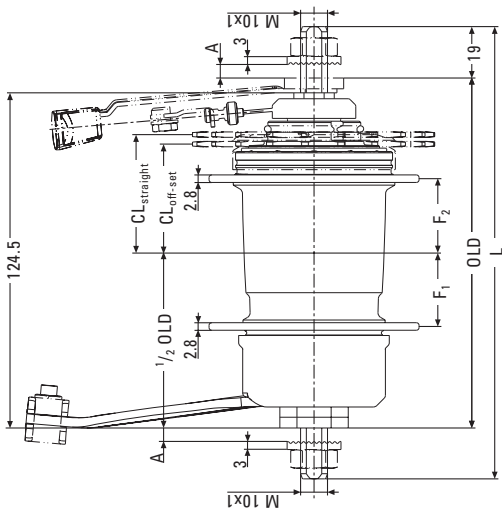
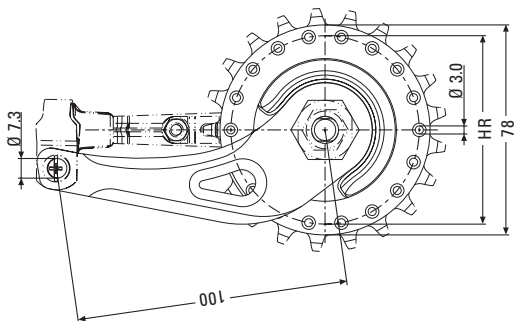

Version with back pedal brake

WORLD HEADQUARTERS

Chicago, Illinois U.S.A.
SRAM Corporation
1333 North Kingsbury, 4th floor
Chicago, Illinois 60622
phone: +1-312-664-8800
fax: +1-312-664-8826

EUROPEAN HEADQUARTERS

Amersfoort, The Netherlands
SRAM Europe
Basicweg 12-D
3821 BR Amersfoort
The Netherlands
phone: +31-33-450-6060
fax: +31-33-457-0200

ASIAN HEADQUARTERS

Taichung, Taiwan
SRAM Taiwan
No. 1598-8 Chung Shan Road
Shen Kang Hsiang, Taichung
County 429
Taiwan
phone: +886-4-2561-3678
fax: +886-4-2561-3686

www.sram.com

SRAM[®]

