

1E48F

ASSEMBLY DRAWING OF ENGINE

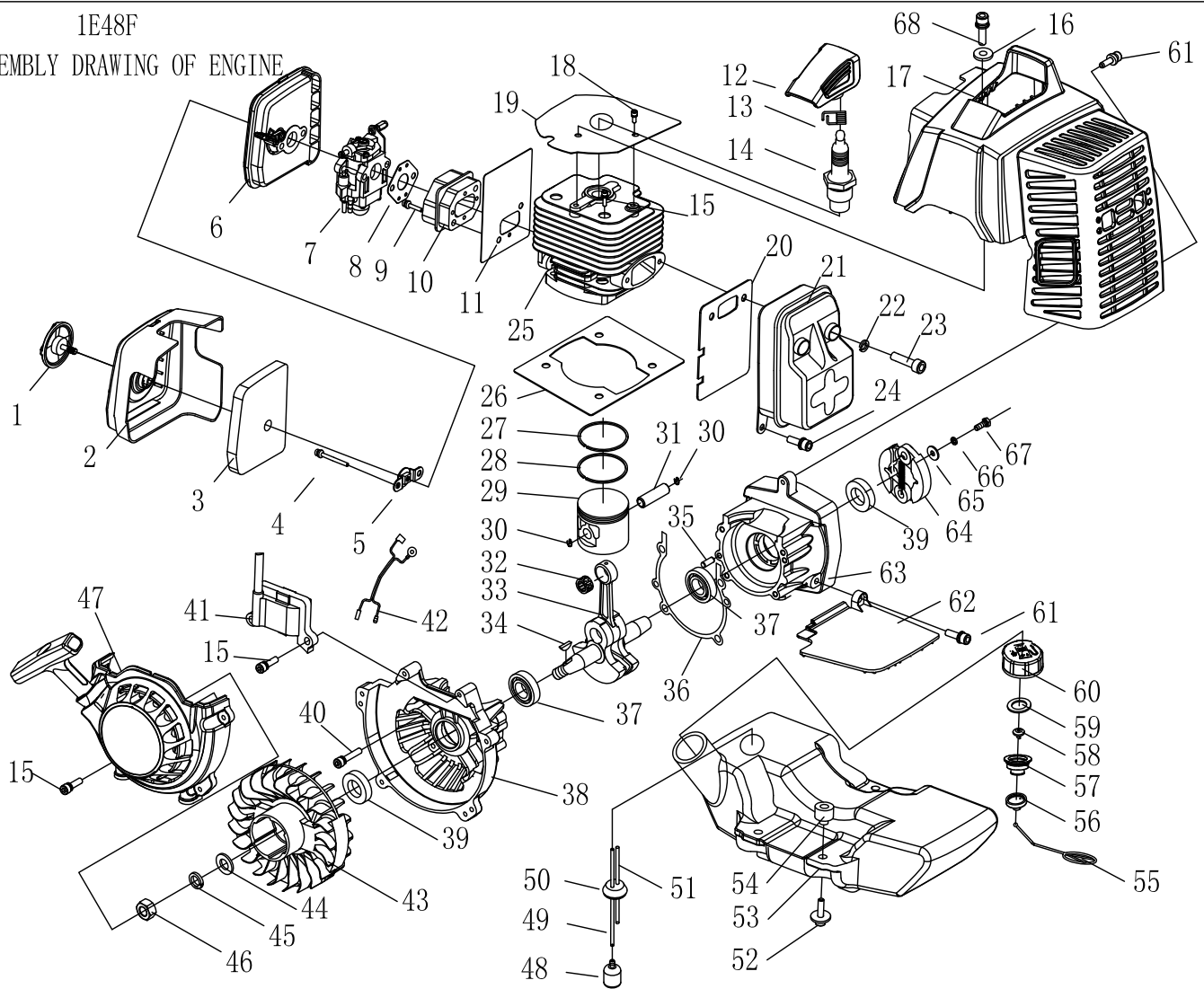

NO.	PART NO.	PART NAME	QTY.	NO.	PART NO.	PART NAME	QTY.	NO.	PART NO.	PART NAME	QTY.
1	1E48F. 1. 2	Screw	1	29	1E48FP. 5-5	PISTON	1	57	1E32FL. 6. 2-2	Inside Cover	1
2	1E48F. 1-1	Cleaner Outside Cover	1	30	1E40F-03. 02. 01	RING	1	58	EB-415. 4. 1. 1-1	Inlet	1
3	1E48F. 1-2	Filter Net	1	31	1E48FP. 5-2	PISTON PIN	1	59	CG420. 1. 3. 1-2	Gasket	1
4	GB70. 1+GB93+GB97	Screw M5 × 50	2	32	1E44F-2A. 2-3	Bearing	1	60	1E32FL. 6. 2-1	Fuel Tank Lid	1
5	GMF-30. 1-13	Baffle (thickness 1.5mm)	1	33	1E48F. 7. 1	Crank Shaft Ass'y	2	61	GB70. 1+GB93+GB97	Screw M5 × 16	2
6	1E48F. 1. 1	Cleaner inside cover	1	34	GB1099	KEY 3 × 13	1	62	1E48F-2	Clapboard	1
7	1E48F. 2Z	Carburetor	1	35	GB119	Pin 4h8 × 10	2	63	1E48F. 8-1	Crank Case	1
8	1E48FP-3	Gasket	1	36	1E48FP. 6-2	Gasket	1	64	1E48F-E. 5	Clutch	1
9	GB70. 1+GB93+GB97	Screw M5 × 30	2	37	GB/T276	Bearing 6202/P6	2	65	GB/T96	Washer 6	1
10	1E48FP-5	Admitting Pipe	1	38	1E48F. 8-2	Crank Case	1	66	GB/T93	Washer 6	1
11	1E48F-5	Gasket	1	39	1E40FP-3Z-11	Seal	2	67	1E40F-6-4	Bolt	1
12	1E48F. 5. 1-1A	Cap	1	40	GB70. 1+GB93+GB97	Screw M5 × 30	4	68	GB70. 1	Screw M5 × 16	1
13	1E34FL-3E. 6-1	Spring	1	41	1E48F. 5. 1. 2A	Coil	1	69			
14	L8RTC	Plug	1	42	1E36F-2C. 6. 1	Cord Comp.	1	70			
15	GB70. 1+GB93+GB97	Screw M5 × 20	10	43	1E48F. 5. 1. 1	Fly Wheel	1	71			
16	1E33F-4	Gasket	1	44	GB/T97	Washer 10	1	72			
17	1E48F. 3(1E48F. 3A)	Guide Cover Ass'y	1	45	GB/T93	Washer 10	1	73			
18	GB70. 1+GB96	Screw M5 × 12	1	46	GB/T6171	Nut M10 × 1. 25	1	74			
19	1E48F-1	Clapboard	2	47	1E48F. 6	Starter	1	75			
20	1E48F-E-5	Gasket	1	48	P40. 12. 2-3A	Filter	1	76			
21	1E48F. 4(1E48F. 4A)	Muffler	1	49	CG420. 4. 2-2	Fuel pipe 3 × 1. 25 × 260	1	77			
22	GB/T859	Washer 8	2	50	EB-415. 4. 2-2	Plug	1	78			
23	GB/T70. 1	Screw M8 × 30-10. 9	2	51	EB-415. 4. 2-4	Fuel pipe 3 × 1 × 90	1	79			
24	GB70. 1+GB93+GB97	Screw M5 × 12	1	52	GB70. 1+GB93+GB96	Screw M5 × 25	1	80			
25	1E48F-4	Cylinder	1	53	1E48F. 9. 1	Fuel Tank	1	81			
26	1E48FP-10	Gasket	1	54	1E48F. 9. 1. 1	Gasket	3				
27	1E48FP. 5-3	Piston Ring	1	55	HB33. 2. 2. 1	Chain	1				
28	1E48FP. 5-4	Piston Ring	1	56	1E32FL. 6. 2-3	Cover	1				