

Technical documentation

GIGA X3

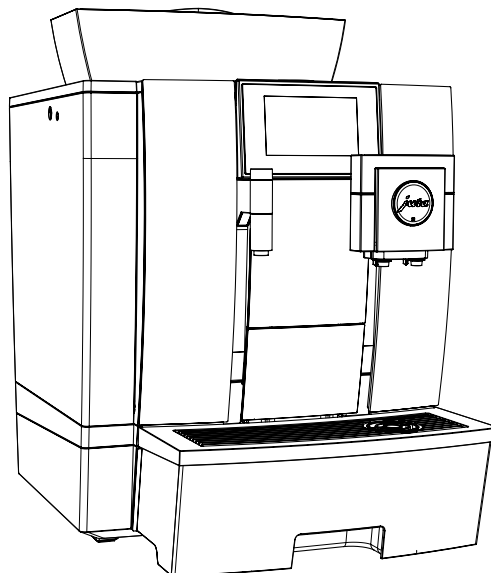

Supplied as standard

- Automatic speciality coffee machine
- Milk system cleaner, 100 ml
- Container for milk system cleaning
- CLARIS Pro Smart filter cartridge
- Welcome Pack:
 - Instructions for use
 - Cleaning tablets
 - Air intake pipe
 - Silicone hose and connector
 - Spanner with hexagonal hole (for milk system)

Requirements for installation location

- Horizontal surface that is not sensitive to water
- Ambient conditions:
 - Air humidity max. 80%
 - Ambient temperature 10–35°C

i The required connections at the customer's premises must be carried out by an approved **qualified person** before the JURA service technician can set up the GIGA at your chosen location.

i Please make sure that the building connections are as close as possible to the location of the machine (refer to length of connection pipes).

Always note the information in the instructions for use for your coffee machine (Chapter 1 "Preparing and using for the first time" – "Requirements for first-time use" / "Setting up the machine").

Dimensions

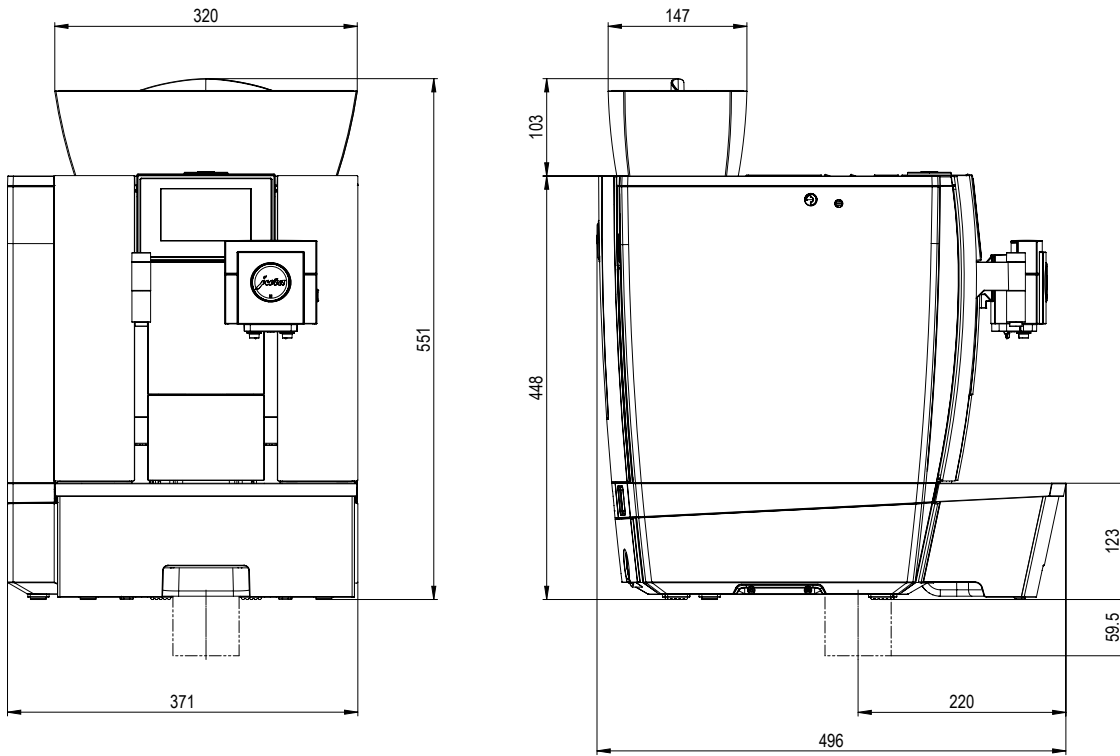

Outline

Side outline

General space needed

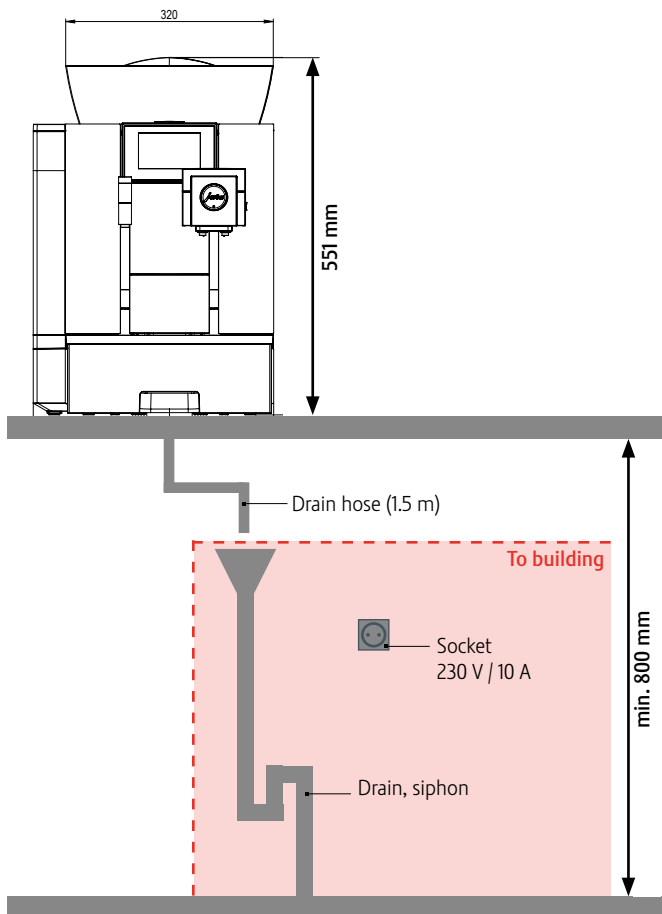

Holes for coffee grounds disposal / drip drain set GIGA^{G2}

Position of separate holes in work surface for permanent water connection and drain hose

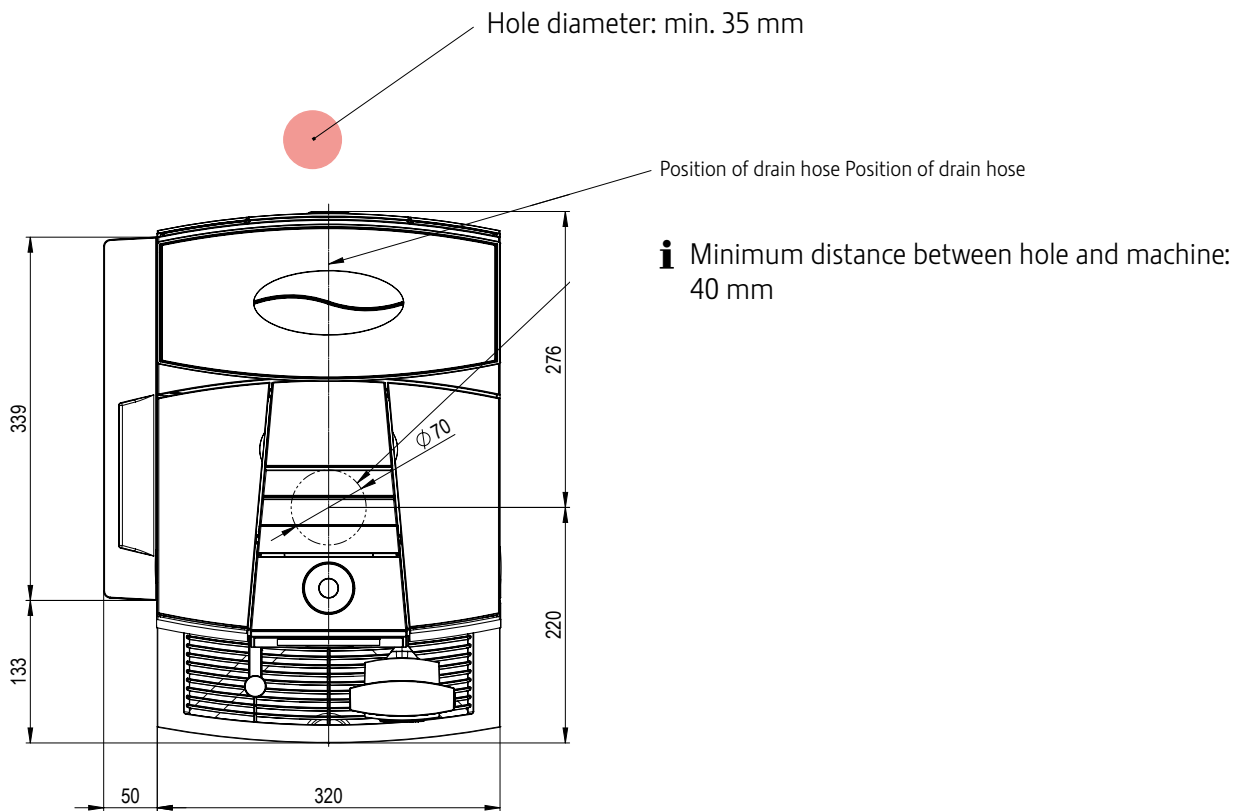

Position of hole in work surface for coffee grounds disposal

