

NOTE: White ground wire not shown in illustration.

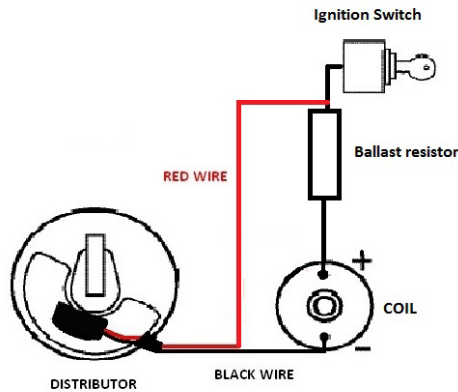

LIMITED WARRANTY

Pertronix, Inc. Warrants to the original Purchaser of its solid-state ignition system (product) that the Ignitor, magnet assembly and wiring (components) shall be free from defects in material and workmanship for a period of (30) months from the date of purchase.

If within the period of the foregoing warranty Pertronix finds, after inspection, that the product or any component thereof is defective, Pertronix will, at its option, repair such products or component or replace them with identical or similar parts PROVIDED that within such period Purchaser:

1. Promptly Notifies Pertronix, in writing, of such defects.
2. Delivers the defective products product or component to Pertronix (ATTN: Warranty) with proof of purchase date; and
3. Has installed and used the product in a normal and Proper manner, consistent with Pertronix printed instructions.

THE FORGOING LIMITED WARRANTY IS EXCLUSIVE AND IN LIEU OF ALL OTHER WARRANTIES, WHETHER EXPRESSED OR IMPLIED, INCLUDING AND IMPLIED WARRANTY OR MERCHANTABILITY OR FITNESS FOR A PURPOSE.

THE FURNISHING OF A REPAIR OR REPLACEMENT COMPONENTS SHALL CONSTITUTE THE SOLE REMEDY OF PURCHASER AND THE SOLE LIABILITY OF PerTronix WHETHER ON WARRANTY, CONTRACT OR FOR NEGLIGENCE, AND IN NO EVENT WILL PerTronix BE LIABLE FOR MONEY DAMAGES WHETHER DIRECT OR CONSEQUENTIAL.



440 E. Arrow Highway, San Dimas, CA. 91773
909-599-5955 www.pertronix.com

IGNITOR[®]

ELECTRONIC IGNITION

12-Volt Negative Ground Instructions

For Part Number: LU-1122A (Excludes Fuel Injection applications)

Before installing, please read the following important information....

1. The Ignitor is not intended for Fuel Injection applications and will not trigger the fuel injection or computer controlled systems!
2. The Ignitor is designed for 12-volt negative ground systems.
3. The Ignitor is compatible only with a "resisted style" coil. Twelve cylinder engines require a minimum of 1.5 ohms of primary resistance.
4. If your Ignition coil has the proper primary resistance, remove or bypass all external resistors. Do not remove resistors if the coil primary resistance is lower than specified.

PRIOR TO INSTALLATION TURN IGNITION SWITCH OFF OR DISCONNECT THE BATTERY

1. Turn the ignition switch off and disconnect the battery negative (-) cable.
2. Disconnect the distributor harness from the ignition amplifier. Disconnect and remove the amplifier from the vehicle.
3. Remove the distributor cap without disconnecting the spark plug wires.
4. Remove the distributor rotor.
5. Remove the c-clip and plastic trigger wheel.
6. Remove the tension spring from the plastic vacuum plate. Remove the vacuum plate and module from the distributor. (See Illustration A).
7. Clean the inside of the distributor housing and distributor shaft.
8. Install the new black plastic vacuum plate into the distributor. Work the vacuum plate over the center distributor hub. Lift the vacuum arm onto the plastic advance plate pin. (See Illustration B).
9. Install the tension spring into the new plastic advance plate.
10. Place the Ignitor module and plate into position. The module should be positioned over the vacuum advance arm.

FIGURE A

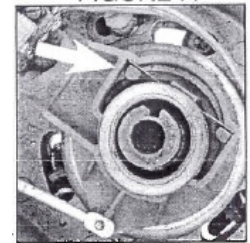

FIGURE B

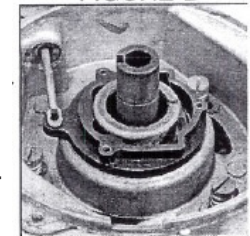
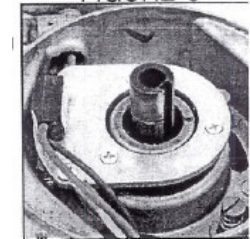
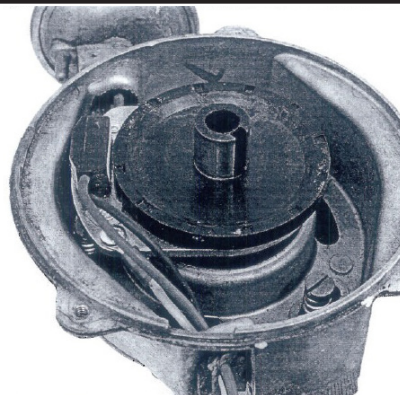

FIGURE C



11. Use the provided #6 screws to fasten the Ignitor plate to the plastic vacuum plate. (See Illustration C).
12. Feed the wires through the hole in the distributor housing and pull the fgmrommet into place. Pull the excess wire out of the distributor housing.
13. Install the magnet sleeve onto the distributor shaft. Line the key way up and press down fully.
14. Install the c-clip onto the distributor shaft.
15. Install; the distributor rotor and cap.



WIRING INSTRUCTIONS (EXCLUDES FUEL INJECTION APPLICATIONS)

1. Remove ballast resistor(s) when installing the recommended 1.5 ohm Flamethrower coil.
2. Connect the Ignitor black wire to the negative (-) side of the ignition coil.
3. Connect the Ignitor red wire to the positive (+) side of the ignition coil.
4. Reconnect battery and make sure all wires are connected.
5. The engine can now be started. Let the engine run for a few minutes and then set the timing in the conventional manner.
6. NOTE: **For installations that use a primary ballast resistor, connect the IGNITOR RED WIRE to the ignition switch side of the resistor and the Ignitor Black Wire to the negative terminal of the coil. SEE BACK PAGE FOR ILLUSTRATION.**

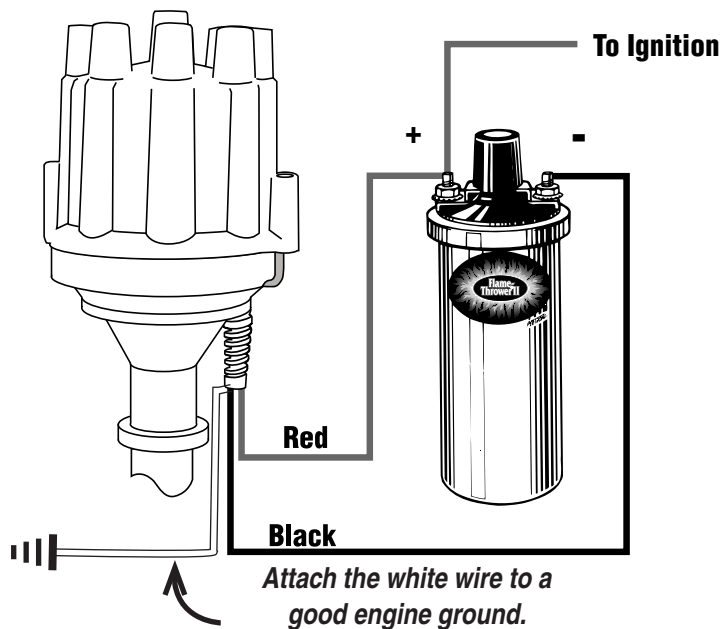

Ignitor COMMON QUESTIONS AND ANSWERS

Q. What is the first thing I should check if the engine would not start?

A. Make certain all wires are connected securely to the proper terminals.

Q. The engine will not start or runs rough. Are there any tests I can do?

A. Yes, remove the red ignitor wire from the coil. Connect jumper wire from the positive side of the battery to the red ignitor wire just removed from the coil. If the engine starts, then you have a low voltage problem . Remember this is just a test. Not intended for permanent installation.

Q. How can I fix a low voltage problem?

A. First, if you have an external ballast resistor or resistance wire, connect the red ignitor wire to the ignition wire prior to the ballast resistor or resistance wire. Second, if you do not have a an external resistor you must connect the ignitor red wire to a 12-volt source that is controlled by the ignition switch.

Q. Should I remove the starter bypass wire?

A. No, the starter bypass wire is needed to provide voltage while starting (cranking).

Q. What type of coil do I need?

A. The ignitor is compatible only with a "points type" coil. Eight cylinder engines require a minimum of 1.5 Ohms of resistance in the primary circuit. Four & six cylinder engines require a minimum of 3.0 Ohms of resistance (primary).

Q. How do I check my coil for resistance?

A. First you need an ohmmeter. Remove all the wires from the coil. Attach the ohmmeter to both the positive and negative terminals. The reading should be 1.5 Ohms or greater for eight cylinder engines and 3.0 Ohms or greater for six cylinder engines. (Your local auto parts store can do this for you if you don't have an ohmmeter)

Q. What do I do if my coil does not have enough resistance?

A. You may purchase and install a ballast resistor from your local auto parts store. You may also choose to purchase a Flamethrower 40,000-volt coil, which provides resistance internally. Note: Many vehicles come with ballast resistor or resistance wire. These applications do not need an additional resistor.

Q. What happens if you leave the ignition switch on when the engine is not running?

A. This can cause your coil to overheat, which may cause permanent damage to the coil and the ignitor.

Q. May I modify the length of the wires?

A. Yes, you can cut the wires to any length your application may require. You may also add length of wire if needed (20-gauge wire). Please make sure all wire splice are clean and connections are secure.

Q. Will the shift interrupter on an OMC stern drive boat work with the ignitor?

A. The ignitor is compatible with all OMC stern drive applications, when equipped with a "diode fix". If you purchased a kit that does not include the "diode fix" diagram, call our tech line.

Q. How can I get additional help?

A. Call our tech line (909-547-9058) for any further instructions or questions.