



A PerTronix Performance Brand ~ www.pertronixbrands.com ~ 909 599-5955

Installation Instructions & Warranty Information

D690YS ~ 1964-70 Ford Mustang, 1967-70 Cougar
260-302 Manual Trans
Long Tube Tri Y Headers



2

This product is legal for use on 1975 and older Non-Catalyst equipped vehicles and is considered a "Replacement Part" per California Air Resources Board regulations, providing ALL emissions sensitive components are retained, including EGR, A.I.R., Heat Risers, etc. and any original or retrofit PCV or NOx device is required for the year of the vehicle. Failure to retain any of these components, or use on ANY originally catalyst equipped vehicles, would render this product illegal for street or off highway use and may only be used for Closed Course Competition.

⚠ WARNING:

This product can expose you to chemicals including Lead, Nickel, Cadmium and Chromium which are known to the State of California to cause cancer and birth defects or other reproductive harm. For more information go to www.P65Warnings.ca.gov

REV. 6-21-24 GW

PLEASE READ BEFORE PROCEEDING

PerTronix® thanks you for choosing a Doug's Headers Product. To realize the potential of Doug's Headers engineering and excellent fit, Please Read and Understand these instructions completely prior to starting the installation.

Check that you received all the parts listed on the parts list, if you have any concerns, please contact PerTronix before continuing. Headers will have the part number stamped in the flange.

Many factors affect the installation of exhaust headers, including worn or aftermarket motor mounts, previous accident damage, aftermarket cylinder heads that may have relocated port or spark plug locations, suspension and steering changes, sagging of original unibody structures due to age.

Coating Notes: Coatings can be marred during installation if you are not careful. If you are breaking in a new motor, the extreme heat can alter the appearance of the coating and this is not a warranty issue. We recommend breaking in new motors with stock manifolds or an old set of headers.

We use sealing beads on all our headers. The raised bead creates a better seal virtually eliminating leaks if installed properly. It is important to install all header bolts lightly snug and then tighten to factory torque specs starting in the center and working outward.

Before starting, allow the vehicle to cool, disconnect the battery, and spray a penetrating oil on all hardware and fittings that will need to be removed. Once you remove your manifold, clean the sealing surface on the head of any old gasket debris or carbon build up.

Work Smart – Work Safe! Most Header and Exhaust Installation are best performed on a lift. If a lift is not available, raise the vehicle and support on quality Jack Stands on level ground. Do not rely on a jack!

- Power Steering cars require bracket #H7609
- Will Not fit GT40P heads

DISASSEMBLY

- 1) Remove and mark all spark plug wires and then remove all spark plugs.
- 2) Disconnect the head pipes from the exhaust manifolds and remove the manifolds.
- 3) Remove the power steering ram from the frame.
- 4) Remove the clutch linkage.
- 5) Remove any gasket material or any carbon deposits that remain on the head surface.

INSTALLATION

1. Start the driver side header from below and work it up through the chassis into position.
2. Start all the header bolts and tighten evenly starting from the center outward

3. Reinstall the power steering ram with a purchased bracket P/N H7609. It may be necessary to reroute the power steering lines for header clearance.
4. Check the steering lockout rod, which may also require bending (to fit) or removal. If removed, the linkage to which it was attached must be wired in place to prevent steering from locking while the vehicle is moving.
5. Start the passenger side header from below and work it up through the chassis into position.
6. Start all the header bolts and tighten evenly starting from the center outward
7. Replace the spark plugs and spark plug wires.
8. If the collector contacts the emergency brake cable, the bracket must be relocated so the cable will clear. See Figures A & B below
9. Use the supplied reducers to connect the collectors to your stock exhaust system.
10. Connect the negative battery cable.

FIGURE A

(VIEW FROM UNDER THE VEHICLE)

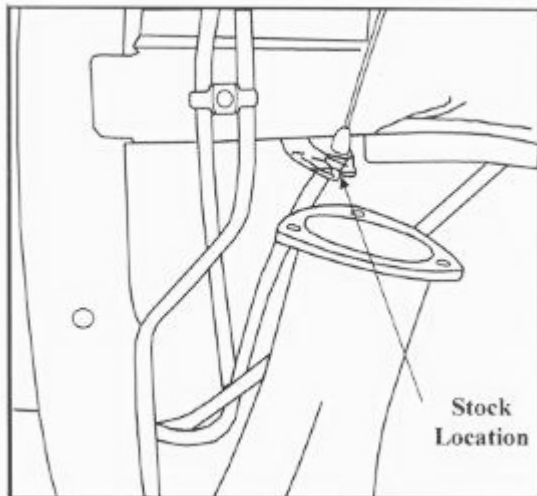
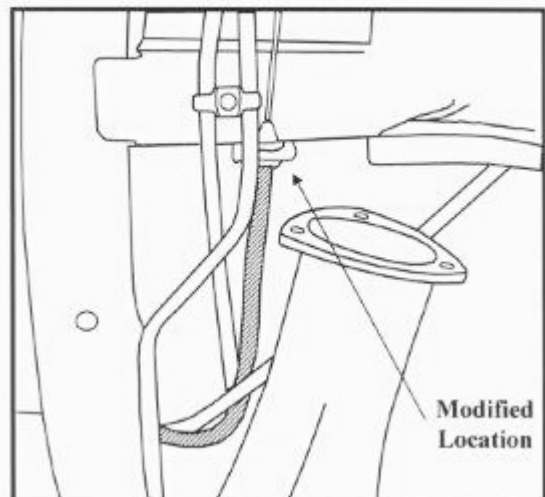

FIGURE B

(VIEW FROM UNDER THE VEHICLE)



IMPORTANT CHECK LIST

- Be sure that all brake lines, transmission lines, and fuel lines are clear of headers and/or connector pipes.
- All spark plug wires, battery cables, or other electrical components should be clear of headers and/or connector pipes.
- If dipstick tube was removed, make sure it is installed properly and that the dipstick has been replaced.
- Double-check the tightness of all bolts including brackets and accessories.

START THE ENGINE

Start the engine and allow it to warm up to operating temperature. Check for any unusual noises or exhaust leaks. If everything is OK, stop the engine and tighten all bolts while the engine is still warm. **NOTE:** Check the bolts periodically to make sure they have not loosened. Re-tighten after the first 500 miles and then again at 1000 miles

PARTS LIST:

1	Left Side Header	16	3/8 x 1" Header Bolts
1	Right Side Header	22	Lockwasher
2	Header Gaskets	6	3/8-16 x 1 1/4" Hex Head Bolts
2	Reducer Gaskets	6	3/8-16 Hex Nuts
2	Reducers		

DOUG'S HEADERS LIMITED WARRANTY

All Doug's Headers and Exhaust products are guaranteed, to the original purchaser, to be free of defects in material and workmanship for one year from date of purchase. This warranty covers the replacement or repair of the product and does not cover the cost of removal and installation, customer applied coatings, or Any discoloration or corrosion of finished surfaces.

Damage or product failure resulting from collision, improper installation, off road use, road hazards, the use of exhaust insulating wrap, or rust occurring after installation is not covered by the warranty. This warranty extends only to the original purchaser.

Should a part be deemed defective, it should be returned to the original selling retailer and must be accompanied by the sales receipt. If there is no retailer in your area, contact PerTronix direct for a return authorization and return the part prepaid to the factory for inspection. PerTronix reserves the right to replace or repair the alleged defective part and return the part freight collect.