



MICROWAVE SENSOR INSTRUCTION MANUAL CAR TRUNK FOOT KICK SENSOR

Product model: TZKJ102K

Please read this manual carefully before installation

START THE ELEGANT CAR LIFE WITH ONE FOOT INTELLIGENT POWER TAILGATE

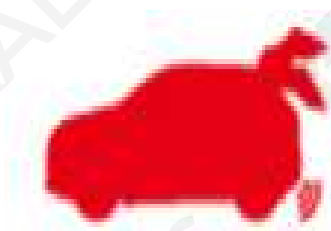

Open with one foot



Non-destructive installation



Quickinstall

Product implementation standard number: Q/LC0001201

PRODUCT INTRODUCTION

Most car trunks on the market today require a key or manual button to open. When the owner holds a large item and wants to put it into the trunk, he must first place the item on the ground, then open the trunk by hand, and finally pick up the item and put it in the car.

This kind of car trunk opening method is inconvenient to operate, which reduces the use experience of the car trunk.

TZKJ102K is a microwave sensor aimed at solving the above problems. It is installed on the inner side of the fender at the rear of the car and emits microwaves downward for detection. If the sensor detects a valid kick in the sensing area, it will output a corresponding level signal according to the signal strength to control the opening of the tail box.

After installing the TZKJ102K microwave sensor, the car owner can easily open the trunk of the car by kicking, and no longer feel inconvenient for holding large items in his hands.

PRODUCT APPEARANCE

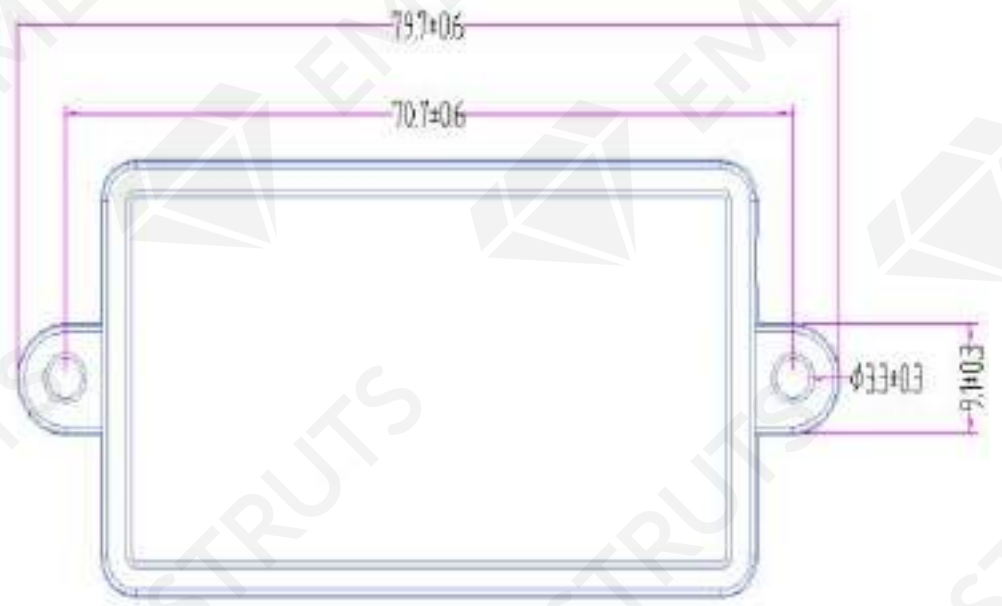
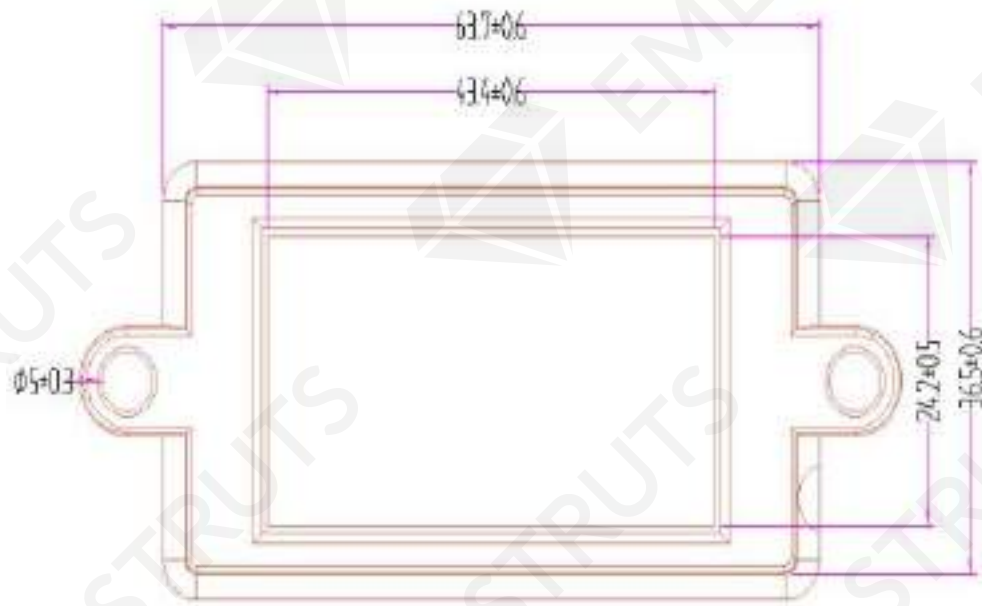

PIN DESCRIPTION



Cable description

Red: Positive power supply DC 5~18V
Black: negative power supply
Green: Signal output



Microwave sensor sensing surface: 24.125GHz

Note:

The green wire harness is the output pin, its normal state is 3.3V high level, and it will output about 0.2V low level when working. Due to the diode protection at the output end, the output pin can be directly connected to the 12V of the original car button. If a valid kick signal is detected, the sensor will output a low level for about 1.5s.

MICROWAVE WORK INSTRUCTIONS

The microwave module of TZKJ102K microwave sensor adopts intermittent working mode, so it adopts pulse mode for power supply. The pulse frequency is 2 KHz, the power supply time of one pulse is 22us, and the duty cycle of the microwave module is about 4.4%.

ELECTRICAL PARAMETERS

MICROWAVE MODULE ELECTRICAL PARAMETERS

Parameters	Sign	Minimum value	Typical value	Maximum value	Units	Explain
Trasmission frequency	FStandard	24.0000	24.125	24.25	GHz	
Output Power	Pout		12		dBm	
Temperature Drift	Δf		1		MHz / °C	
Startup time	St	0.6	0.8	1	uS	Microwave activation time
Operating Voltage	VCC	3.1	3.3	3.6	V	
Sensing angle	Horizontal direction		80		°	Left and right opening angle
	Vertical direction		20		°	Up and down opening angle
Operating temperature	TOP	-40		85	°C	
Absolute limit value						
Operating Voltage	VCC	5.5			V	
Operating temperature	TOP	-40 / +85			°C	
Storage temperature	TSTG	-45 / +90			°C	

MICROWAVE SENSOR ELECTRICAL PARAMETERS

Power supply voltage	DC 5 - 18 V	Power-on start time	About 2 s
Operating current	About 5 mA	How microwaves work	Intermittent
Microwave duty cycle	4.40%	Operating temperature	-40~ + 85 °C
Trasmission frequency	24.125 ± 0.125 GHz	Protection class	IP68

INSTALLATION STEPS

1. Wipe the inner side of the rear fender to be installed first, and there should be no foreign objects such as mud, dust and accumulated water. It is best to install the sensor in the middle of the rear of the vehicle.



2. Use a tape measure to determine the installation position of the kick sensor. The installation position is 70mm inward from the outer edge of the rear fender. Determine it as the kick installation position, and stick a punch sticker.



3. After confirming the installation position, paste the hole sticker, align the hole mark on the sticker, use the self-contained screw to drill, pay attention to the direction that the screw cap is outside; when the screw is about 1 cm into the fender, stop drilling.

4. Hold down the microwave sensor and continue to screw the screw to fix the microwave sensor.

Note: After tightening the screws, the white glue and the inner side of the fender should be completely fitted, and no gap should be left in the middle to prevent the sand from entering and affecting the use effect.

5. If there are grids, protrusions and other structures on the inner side of the fender, so that the white glue on the module cannot be completely attached to the inner side of the fender, be sure to polish the grid, protrusions and other structures or fill with glass glue, otherwise there will be gaps in the middle. When mixed with water and sediment, the performance of the sensor will be greatly affected.

SENSING AREA

The effective sensing area is about 20cm below the sensor, the front and rear depth is about 5cm, and the width W is about 25 ~ 30cm.

Note:

Due to the difference in material, structure and height of the rear fenders of different models. The sensing range may deviate from the actual situation.

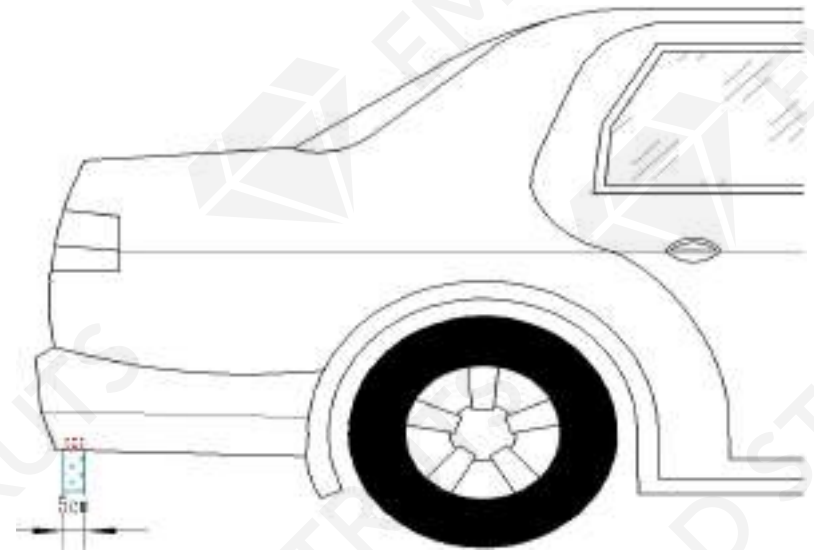

EFFECTIVE KICKING ACTION

For an effective kick action to meet the following conditions:

1. The time for the whole process from lifting to landing is about 1s, and the process of lifting and falling of the foot does not need to be slowed down deliberately.
2. The lifting and falling process of the foot must be continuous, and the foot must fall immediately after the lifting process is completed, and there should be no pause in between.
3. The feet must enter the sensing area, and the toes must pass through the front and rear depth of 50mm.

A valid kicking action is shown in the following figure:

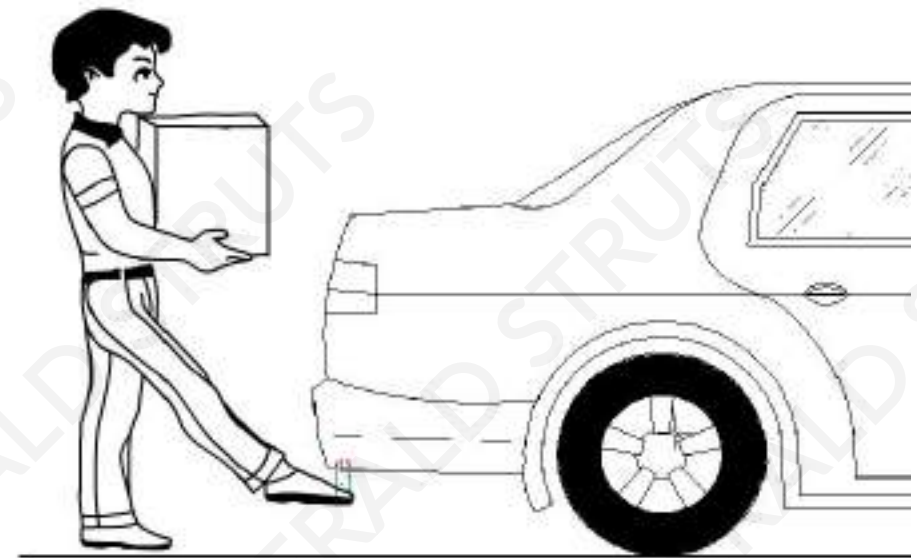

COMMON WRONG ACTIONS

1. After the foot is lifted, there is a pause in the air for a period of time, and then it falls.

2. It is not a natural kicking action, the speed is too fast or too slow.

3. The foot does not enter the effective sensing area.

3. The foot does not enter the effective sensing area.

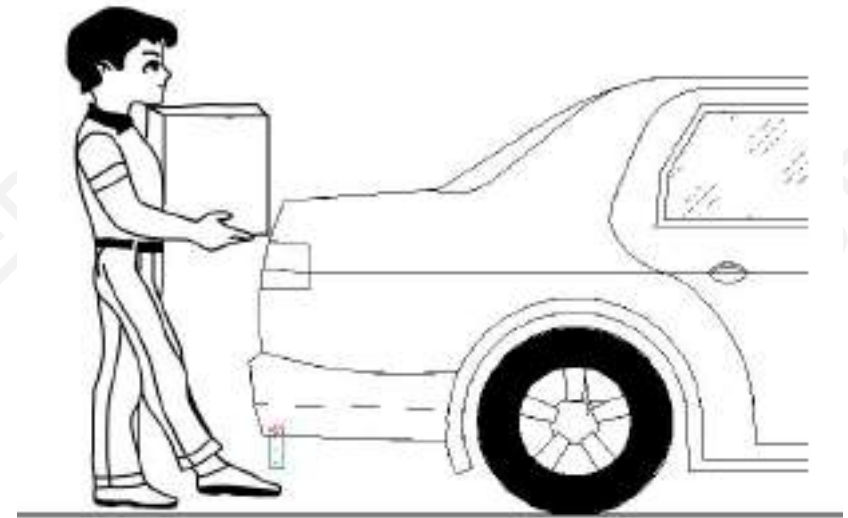

4. The toes only enter the sensing area, but do not reach the depth of the sensing area.

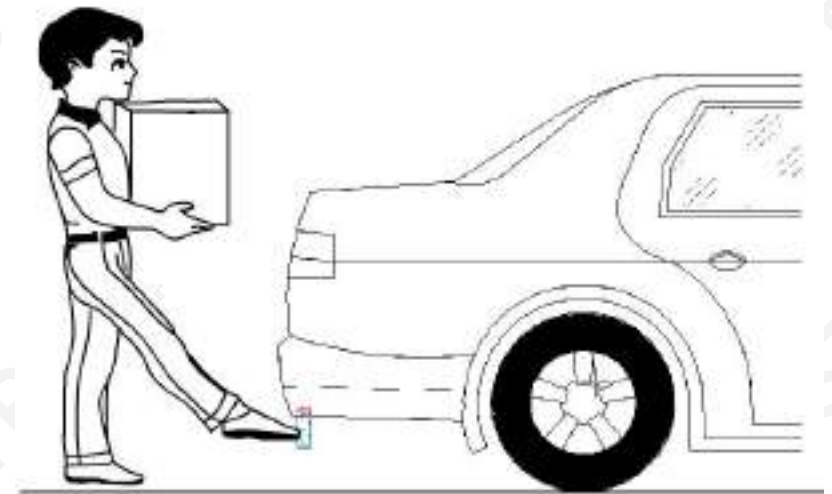

EXTENSION CABLE CONNECTION METHOD

1. **Red wire (positive power supply):** connect to the 12-volt constant current of the original car;
2. **Black wire (negative pole of power supply):** grounding;
3. **Green wire (button wire):** use one end of the test pen and the other end of the tower iron to maintain good contact with the wire on the original tailgate button socket. At this time, press the original tailgate button, the light of the test pen will light up, press when it lights up, it is the tailgate button line.

