

Bass Mic: Clip-On Mic for Bass

DESCRIPTION

The Bartlett Bass Mic is a professional quality, miniature microphone that attaches to a bass f-hole for sound reinforcement. Specially voiced to sound best on a bass, the mic provides a full, mellow tone. Applications include old-time, bluegrass, and jazz groups.

A bass tends to sound boomy when miked in an f-hole. The low-frequency response of the Bass Mic is rolled off to compensate, resulting in a natural, non-boomy sound.

The Bass Mic has a tiny mic housing with a rugged 8-foot cable attached to an XLR connector which houses the electronics. The microphone requires phantom power, available from most mixers.

FEATURES

- Full, mellow sound -- better than a pickup
- Soft foam mount pressed into an f-hole will not scratch your instrument
- Consistent sound from gig to gig
- Freedom of movement
- High sensitivity and low-impedance balanced output provide a strong, hum-free signal
- Made in USA

SPECIFICATIONS

Type: Miniature omnidirectional condenser microphone.

Transducer: Electret condenser.

Frequency response: 40 Hz to 10 kHz. See Figure 1.

Polar pattern: Omnidirectional. See Figure 2.

Impedance: 200 ohms. Recommended load impedance >1000 ohms.

Sensitivity: 26.6 mV/Pa (-32 dBV/Pa). 1 Pa = 94 dB SPL.

Signal-to-noise ratio: >64 dB at 94 dB SPL. Noise is inaudible in normal use.

Maximum SPL: 134 dB SPL produces 3% THD. The mic will not audibly distort in normal use.

Cable: Permanently attached, 8-foot, black 2-conductor shielded cable with XLR-type 3-pin connector.

Operating voltage: 18–48V phantom power.

Current draw: 4.5 mA.

Materials: Rugged brass circuit housing/XLR connector.

Finish: Black mic, silver circuit housing/XLR connector.

Net weight: 2.8 oz (79 g).

Dimensions: XLR connector 2.460" long x 0.747" diameter, mic 0.540" long x 0.325" diameter.



Figure 1. Frequency Response

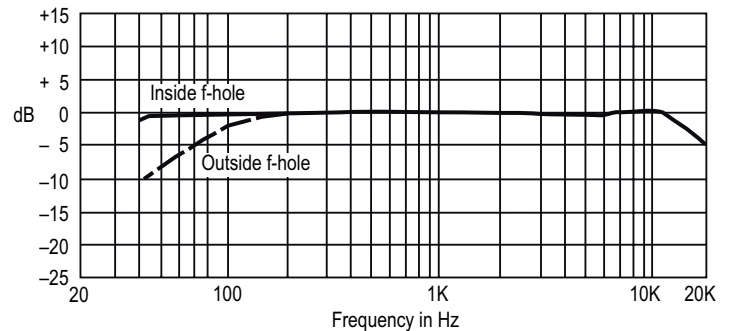
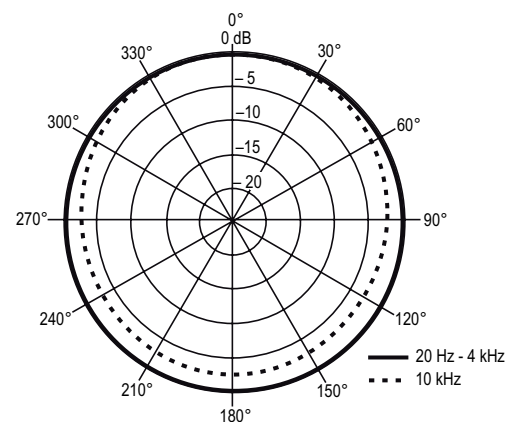

Figure 2. Polar pattern



Bartlett Audio

Weaverville, NC USA
www.bartlettaudio.com

email: info@bartlettaudio.com
© 2014 Bartlett Audio

MOUNTING THE BASS MIC ON YOUR INSTRUMENT

1. Supplied with the Bass Mic is a foam mount about 1 inch behind the mic.
2. Stuff the foam mount in an f-hole with the mic just inside the f-hole.

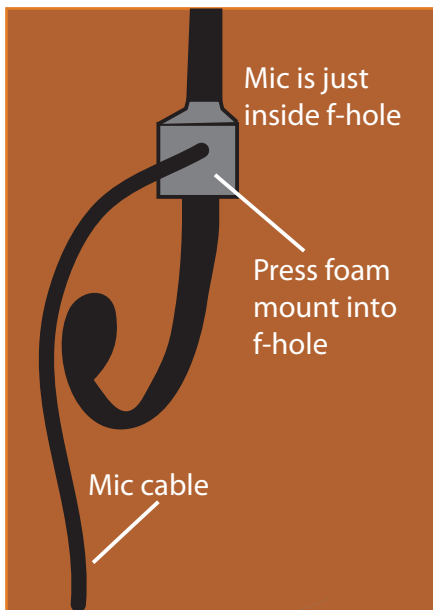

OPERATION

1. Option 1: Plug the mic connector into a mic cable that is connected to a mixer mic input. That input should supply phantom power.
2. Option 2: Plug the mic connector into a mic cable that is connected to a phantom power supply. Then connect the phantom supply output to a mixer mic input.
3. Turn on phantom power before use.
4. The microphone is very sensitive or "hot". Be sure to turn down the input gain trim on your mixer as needed to prevent mixer distortion and feedback.
5. If you also use a pickup, mix the Bass Mic with the pickup to get a variety of tones.

WARRANTY

The Bartlett Bass Mic is guaranteed not to malfunction (except in cases of abuse) for a period of two years from the date of first purchase. Mic cables and paint finish are excluded from this warranty.

SERVICE

For tech support email info@bartlettaudio.com.

If the microphone does not operate correctly, first check its cable and other connected cables. Repair or replace them if necessary. Make sure that phantom power is turned on and that the microphone's fader is up in the mixer.

If the microphone still fails to operate, obtain a return authorization number from us by emailing info@bartlettaudio.com. Then return the mic and its cable in its original packaging to Bartlett Audio. Please include proof of purchase and a note about the problem.

If the microphone's specifications change, any changes will appear in the latest data sheet available online at www.bartlettaudio.com.