

(D) Ersatzteilliste	Motorsäge	646 Modell ab 2009	Inhaltsverzeichnis Motoreinheit: Kurbelwelle, Zylinder, Zündung Auspuff, Vergaser, Luftfilter Ölpumpe, Kupplung, Kettenbremse Hauptgehäuseerschluss, Haube Starter Griffgehäuse, Haltebügel, Handschutz Schwert, Kette, Anschlagkralle, Kettenspannung Richtlinien für die Bestellung Ersatzteile	Seite 2 3 4 5 7 8 10 11 12
(GB) Spare parts list	Chain saw	646 Type → 2009	Table of contents Engine: Crankshaft, Cylinder, Ignition Exhaust, carburetor, air filter Oil-pump, clutch, chain brake Main housing, cover Starter Handle bar housing, hand protection Guide bar, chain, bucking spike, Tension screw / tension carriage Directions for ordering Spare parts	Page 2 3 4 5 7 8 10 11 12
(F) Liste de pièces de rechange	Tronçonneuses	646 Modèle → 2009	Table des matières Moteur : Embiellage, Cylindre, Bobine allumage Echappement, carburateur, filtre à air Pompe à huile, embrayage, fraîn de la chaîne Carter principal, couvercle Lanceur Etrier carter, protège main Guide chaîne, chaîne, griffe de butée, Vis de tension Directives pour les commandes Pièces de rechange	Page 2 3 4 5 7 8 10 11 12
(E) Lista de piezas de recambio	Motosierras	646 Modelo → 2009	Indice Motor: Cigüenal, Cilindro, Bobina Escape, carburador, filtro de aire Bomba de aceite, embrague, freno de cadena Carter principal, cubierta Arranque Asa carter, proteccion de mano Espada, cadena, garra de apoyo, Tornillo de tension Directivas de pedido Piezas de recambio	Página 2 3 4 5 7 8 10 11 12

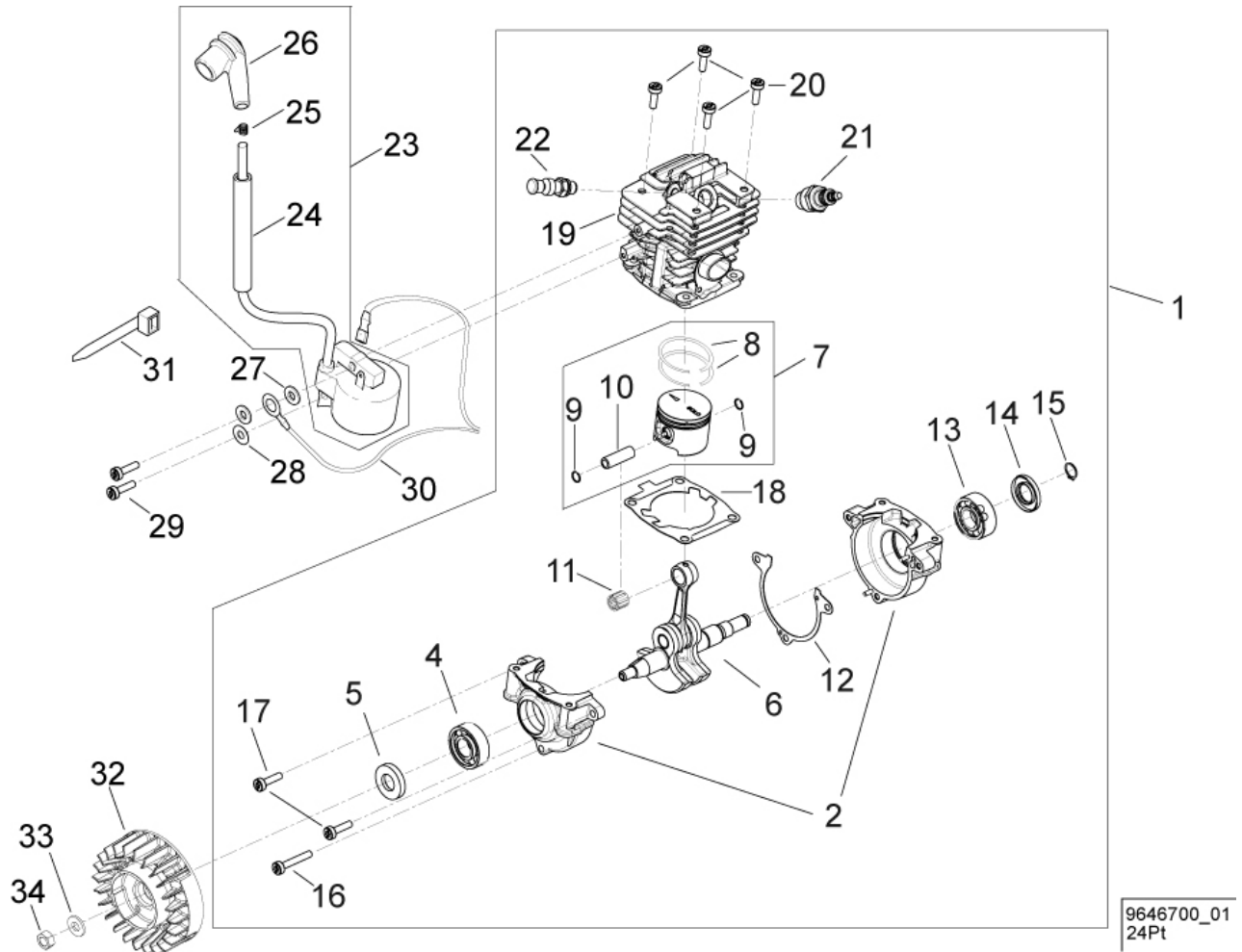

9646700_01
24Pt

Bild-Nr. Pos.-No. No.Pos. Pos.-No.	Bestell-Nr. Order-No. No. de Cde Ref.-Nr.	Menge Quantity Nombres Cantidad	Motoreinheit: Kurbelwelle, Zylinder, Zündung	Engine: Crankshaft, Cylinder, Ignition	Moteur : Embiellage, Cylindre, Bobine allumage	Motor: Cigüenal, Cilindro, Bobina
1	21 00 925	1	Motoreinheit enth. (-> 1 - 22	Engine incl. (-> 1 - 22	Moteur y inclus (-> 1 - 22	Motor incl. (-> 1 - 22
2	21 00 930	1	Kurbelgehäuse	Crankcase	Carter-moteur	Carter cigüenal
4	00 50 102	1	Kugellager 15x35x11 mm	Ball bearing	Roulement à billes	Cojinete de bolas
5	00 54 220	1	Wellendichtring 15x28x5 mm	Oil seal	Joint spy	Reten
6	22 00 620	1	Kurbelwelle	Crankshaft	Embiellage	Cigüenal
7	22 00 323	1	Kolben Ø 42 mm enth. (-> 7 - 10	Piston incl. (-> 7 - 10	Piston y inclus (-> 7 - 10	Piston incl. (-> 7 - 10
8	20 48 229	2	Kolbenring 42x1,5 mm	Piston ring	Segment	Anillo de piston
9	00 55 278	2	Sprengring 9x0,8 mm	Ring	Circlips d'axe de piston	Anillo
10	20 31 117 25	1	Kolbenbolzen 9/6x28 mm (-)	Piston pin (-)	Axe de piston (-)	Bulon (-)
11	00 52 226	1	Nadelkäfig 9x13x12 mm	Needle sleeve	Douille	Casquillo
12	20 61 528	1	Dichtung Kurbelgehäuse	Gasket	Joint	Junta
13	00 50 188	1	Kugellager 15x35x13mm	Ball bearing	Roulement à billes	Cojinete de bolas
14	00 54 251	1	Wellendichtring 15x29,6x4 mm	Oil seal	Joint spy	Reten
15	00 55 136	1	Sicherungsring 15x1 mm	Circlip	Circlip	Anillo de seguridad
16	00 18 339	1	Zylinderschraube M5x30 mm	Screw	Vis	Tornillo
17	00 18 337	2	Zylinderschraube M5x20 mm	Screw	Vis	Tornillo
18	20 61 527	1	Zylinderfußdichtung	Cylinder foot gasket	Joint de cylindre	Junta del cilindro
19	20 11 342	1	Nikasilzylinder Ø 42 mm	Cylinder	Cylindre	Cilindro
20	00 18 336	4	Zylinderschraube M5x16 mm	Screw	Vis	Tornillo
21	23 00 888	1	Zündkerze USR 4AC	Spark plug	Bougie	Bujia
22	28 00 656	1	Dekoventil D 1,0 (-)	Deco-valve (-)	Soupape decompression (-)	Valvula (-)
23	23 00 856	1	Zündmodul Aoxin enth. (-> 23 - 26	Ignition coil Aoxin incl. (-> 23 - 26	Bobine Aoxin y inclus (-> 23 - 26	Bobina Aoxin incl. (-> 23 - 26
24	00 64 292	110 mm	Schlauch 6x1 mm	Hose	Tuyau	Tubo
25	00 73 347	1	Kontaktfeder	Contact spring	Ressort de contact	Resorte de contacto
26	00 84 621	1	Zündkerzenstecker (-)	Spark plug cap (-)	Capuchon de bougie (-)	Terminal de bujia (-)
27	00 30 101	1	Scheibe 4,3 mm	Washer	Rondelle	Arandela
28	00 72 148	2	Spannscheibe 4 mm	Tension spring	Rondelle de tenison	Arandela elastica
29	00 10 574	2	Zylinderschraube M4x20 mm	Screw	Vis	Tornillo
30	00 84 876	1	Kurzschlusskabel	Short circuit cable	Câble	Cable cortocircuito
31	00 66 455	1	Kabelband 98x2,5 mm	Cable band	Frein de câble	Cinta
32	24 00 318	1	Lüfterrad	Fan wheel	Turbine	Turbina
33	00 72 145	1	Spannscheibe 8 mm	Tension spring	Rondelle de tension	Arandela elastica
34	00 20 145	1	Sechskantmutter M8x1	Nut	Écrou	Tuerca

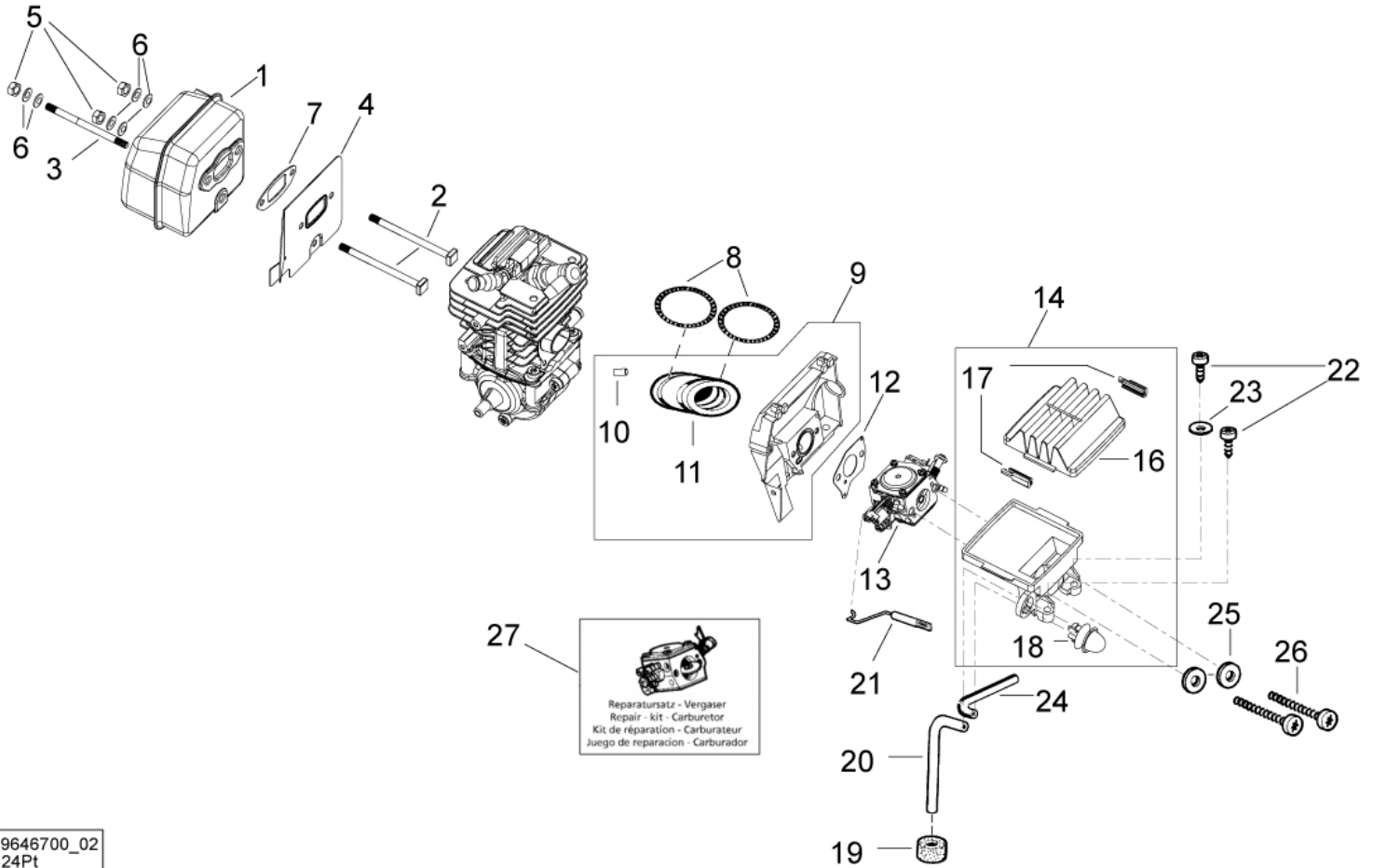

9646700_02
24Pt

Bild-Nr. Pos.-No. No.Pos. Pos.-No.	Bestell-Nr. Order-No. No. de Cde Ref.-Nr.	Menge Quantity Nombres Cantidad	Auspuff, Vergaser, Luftfilter	Exhaust, carburetor, air filter	Echappement, carbureteur, filtre à air	Escape, carbureador, filtro de aire
1	25 00 665 25	1	Auspuff	Exhaust	Échappement	Escape
2	00 18 379	2	Vierkantschraube M5x74 mm	Screw	Vis	Tornillo
3	00 15 301	1	Stiftschraube M5x65 mm	Screw	Goujon	Tornillo
4	20 43 652	1	Luftleitblech	Air guide	Conduit d'air	Guia aire
5	00 28 137	3	Sechskantmutter M5	Nut	Écrou	Tuerca
6	00 72 144	6	Sicherungsscheibe 5 mm	Tension washer	Rondelle de tension	Arandela elastica
7	20 61 476	1	Auspuffdichtung 1,0 mm	Muffler gasket	Joint amortisseur	Junta del escape
8	00 71 153	2	Federring 20	Spring ring	Bague ressort	Resorte
9	23 00 724	1	Vergaserstutzen enth. (-> 9 - 11)	Manifold incl. (-> 9 - 11)	Bride d'admission y inclus (-> 9 - 11)	Brida carburador incl. (-> 9 - 11)
10	00 64 319	1	Schlauch 5x1,5	Hose	Tuyau	Tube
11	60 63 322	1	Verbindungsschlauch <->	Hose connection <->	Raccord admission <->	Tube <->
12	20 61 477	1	Vergaserstutzendichtung 0,5 mm	Manifold gasket	Joint d'admission	Junta carburador
13	23 00 803	1	Vergaser, HDA 170	Carburetor	Carburateur	Carburador
14	25 00 757	1	Luftfilter, vollst enth. (-> 14 -18)	Air filter incl. (-> 14 -18)	Filtre à air, compl., y inclus (-> 14 -18)	Filtro de aire, incl. (-> 14 -18)
16	25 00 688	1	Luftfiltergehäuse Oberteil	Filter lid	Chapeau filtre	Tapa de filtro
17	20 74 946	2	Klemmprofil 4x2x20	Profile	Profil	Perfil
18	27 00 322	1	Primer <->	Primer <->	Pompe d'amorçage <->	Cabador <->
19	60 63 301	1	Schlauchdurchführung	Hose guide	Oeillet	Ojete de tubo
20	00 64 420	1	Schlauch 3x1,5x95mm	Hose	Tuyau	Tube
21	28 00 352	1	Gasgestänge 1	Throttle linkage 1	Tringlerie des gaz 1	Varilla 1
22	00 18 363	2	Linsenschraube 5x20 mm	Screw	Vis	Tornillo
23	00 30 108	1	Scheibe 5,3 mm	Washer	Rondelle	Arandela
24	00 64 407	35 mm	Schlauch 2x1,5 mm	Hose	Tuyau	Tube
25	00 34 201	2	Sicherungsscheibe 5 mm	Tension washer	Rondelle de tension	Arandela elastica
26	00 18 382	2	Linsenschraube 5x55 mm	Screw	Vis	Tornillo
27	05 10 791	1	Reparatursatz - Vergaser	Repair-kit - carburetor	Kit de réparation - carbureteur	Juego de reparacion - carburador

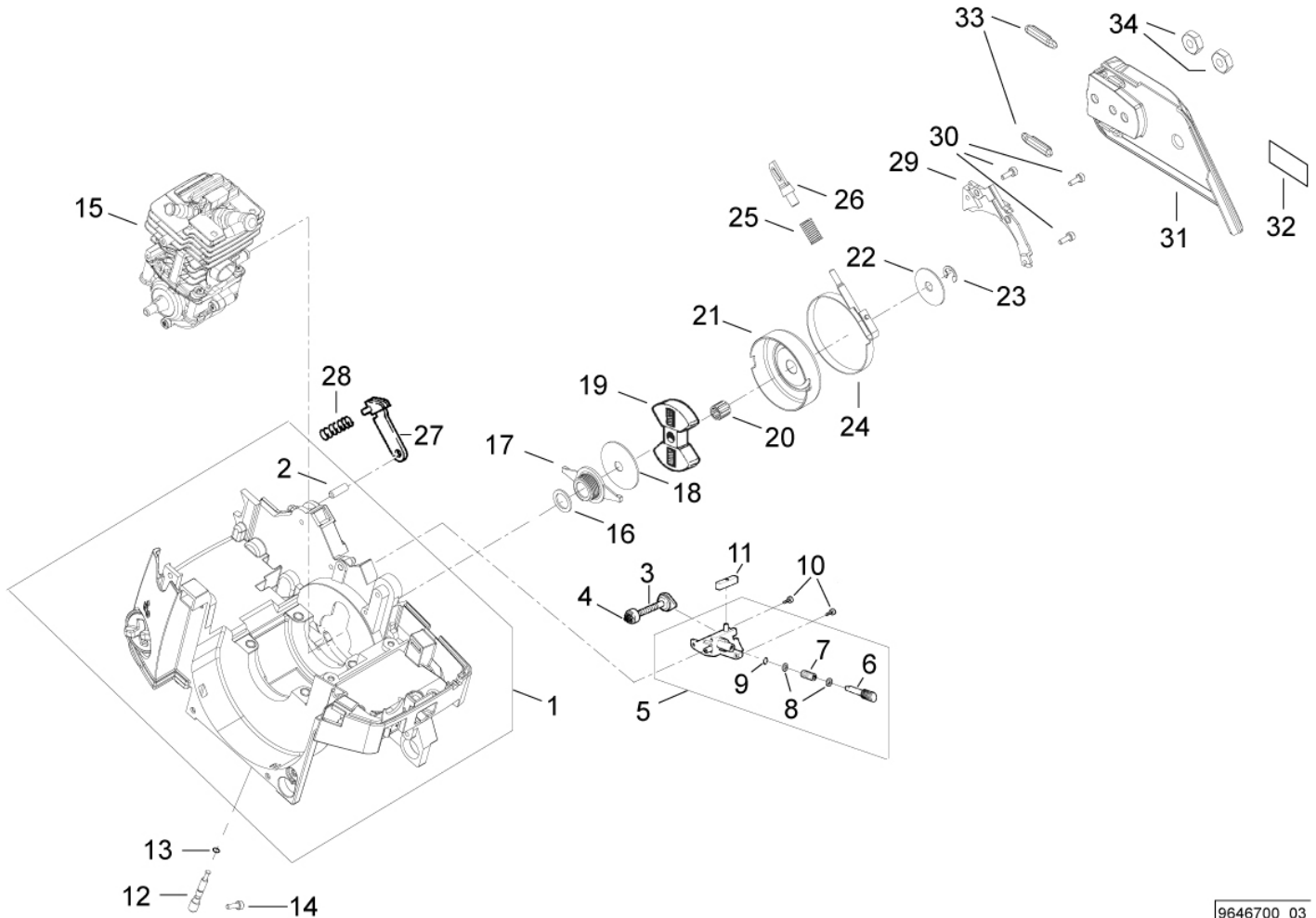

9646700_03
24Pt

Bild-Nr. Pos.-No. No.Pos. Pos.-No.	Bestell-Nr. Order-No. No. de Cde Ref.-Nr.	Menge Quantity Nombres Cantidad	Ölpumpe, Kupplung, Kettenbremse	Oil-pump, clutch, chain brake	Pompe à huile, embrayage, frein de la chaîne	Bomba de aceite, embrague, freno de cadena
1	61 00 140	1	Hauptgehäuse enth. (-> 1, 2)	Main housing incl. (-> 1, 2)	Carter principal y inclus (-> 1, 2)	Carter principal incl. (-> 1, 2)
2	00 40 188	1	Zylinderstift (-)	Pin (-)	Goujon (-)	Perno (-)
3	60 63 329	1	Ölschlauch 3,5x88 mm	Oil hose	Tuyau d'huile	Tubo de aceite
4	67 00 124	1	Ölsieb	Oil strainer	Tamis à huile	Tamiz de aceite
5	64 00 222	1	Ölpumpe enth. (-> 5 - 9)	Oil pump incl. (-> 5 - 9)	Pompe à hulle y inclus (-> 5 - 9)	Juego bomba incl. (-> 5 - 9)
6	60 31 996	1	Pumpenkolben	Pump piston	Piston de la pompe	Piston de la bomba
7	00 70 265	1	Druckfeder 0,5x5,7x27	Spring	Ressort	Resorte
8	00 31 529	2	Scheibe 8x5,1x0,5mm	Washer	Rondelle	Arandela
9	00 62 276	1	O-Ring 4,7x1 (-)	O-ring (-)	Joint torique (-)	Anillo (-)
10	00 18 354	2	Linsenschraube 4x12 mm	Screw	Vis	Tornillo
11	60 63 323	1	Dichtstück	Seal	Caoutchouc d'étanchéité	Junta
12	60 74 997 25	1	Hubstift 3x21,5	Pin	Goujon	Perno
13	00 62 256	1	O-Ring 4x1,2	O-ring	Joint torique	Anillo
14	00 46 145	1	Bolzen 2/5x31	Bolt	Axe de retenue	Perno
15	21 00 925	1	Motoreinheit	Engine	Moteur	Motor
16	00 31 270	1	Scheibe 15x22x0,5 mm	Washer	Rondelle	Arandela
17	60 74 976	1	Mitnehmerschnecke	Activator	Entraîneur à vis	Activador
18	60 42 817	1	Scheibe 12x55x1 mm	Washer	Rondelle	Arandela
19	35 00 405	1	Fliehkraftkupplung M12x1,25	Centrifugal clutch	Embrayage centrifuge	Embrague centrifugal
20	00 52 257	1	Nadelkäfig 10x13x13 mm	Needle sleeve	Douille	Casquillo
21	35 00 362 25	1	Kupplungsglocke .325"	Clutch drum	Cloche embrayage	Campana embrague
22	60 43 990	1	Schutzkappe	Protection cap	Capuchon de protection	Caperuza de protecc.
23	00 55 104	1	Sicherungsscheibe 8 mm	Safety washer	Circlip	Seguro
24	62 00 131 25	1	Bremsband	Brake band	Ruban frein	Cinto del freno
25	00 70 254	1	Druckfeder 1,6x10,2x56	Spring	Ressort	Resorte de presión
26	63 00 208 25	1	Verstellung	Adjuster	Réglage	Regulación
27	63 00 175 25	1	Druckblech	Pressure plate	Tôle	Chapa de presión
28	00 70 253	1	Druckfeder 1,5x7x21,5	Spring	Ressort	Resorte
29	60 74 999	1	Bremsbandabdeckung	Brake band cover	Boîte ruban frein	Cubierta del cinta del freno
30	00 18 354	3	Linsenschraube 4x12 mm	Screw	Vis	Tornillo
31	60 11 728 25	1	Schwertabdeckung	Chain guard	Carter de chaîne	Cubierta espada
32	00 69 788	1	Selbstklebeschild	Sticker	Autocollant	Adhesivo
33	60 74 696	2	Gleitschuh	Guide shoe	Patin	Patin
34	00 20 214	2	Sechskantmutter M8	Nut	Écrou	Tuerca

Hauptgehäuse, Haube

Main housing, cover

Carter principal, couvercle

Carter principal, cubierta

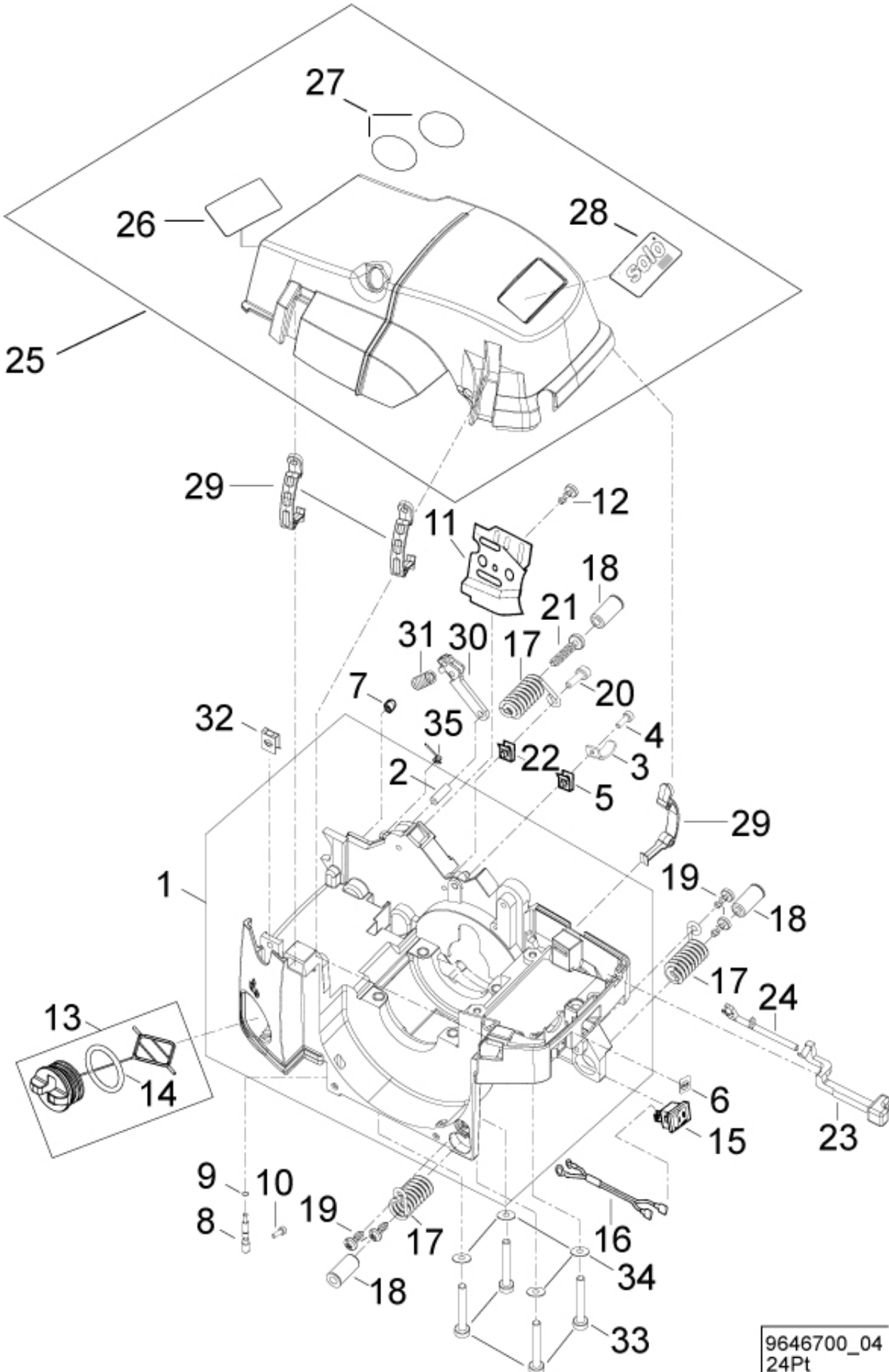

9646700_04
24Pt

Bild-Nr. Pos.-No. No.Pos. Pos.-No.	Bestell-Nr. Order-No. No. de Cde Ref.-Nr.	Menge Quantity Nombres Cantidad	Hauptgehäuse, Haube	Main housing, cover	Carter principal, couvercle	Carter principal, cubierta
1	61 00 140	1	Hauptgehäuse enth. (-> 1, 2	Main housing incl. (-> 1, 2	Carter principal y inclus (-> 1, 2	Carter principal incl. (-> 1, 2
2	00 40 188	1	Zylinderstift (-)	Pin (-)	Goujon (-)	Perno (-)
3	60 43 352	1	Kettenfangblech	Chain protection plate	Tôle guide	Chapa parador de cadena
4	00 18 337	1	Zylinderschraube M5x20 mm	Screw	Vis	Tornillo
5	00 28 157	1	Blechmutter M5	Nut	Écrou	Tuerca
6	00 69 841	1	Selbstklebeschild "STOP"	Sticker "STOP"	Autocollant "STOP"	Placa "STOP"
7	27 00 441	1	Rückschlagventil	Check valve	Soupape antiretour	Valvula
8	60 74 997 25	1	Hubstift 3x21,5	Pin	Goujon	Perno
9	00 62 256	1	O-Ring 4x1,2	O-ring	Joint torique	Anillo
10	00 46 145	1	Bolzen 2/5x31	Bolt	Axe de retenue	Perno
11	60 43 980	1	Kettenführungsblech	Guide plate	Tôle de guidage	Chapa
12	00 13 285	1	Linienblechschraube 3,5x9,5 mm	Screw	Vis	Tornillo
13	27 00 326	1	Tankverschluss, Öl enth. (-> 13, 14	Oil tank cap incl. (-> 13, 14	Bouchon réservoir huile y inclus (-> 13, 14	Tapa de deposito incl. (-> 13, 14
14	00 62 147	1	O-Ring 25,3x2,4 mm (-)	O-ring (-)	Joint torique (-)	Anillo (-)
15	00 84 477	1	Kurzschlusschalter	Short circuit switch	Interrupteur	Interruptor
16	00 84 876	1	Kurzschlusskabel	Short circuit cable	Câble	Cable cortocircuito
17	00 73 397	3	Dämpfungsfeder 2,5x13,5x33	Spring	Ressort amortisseur	Resorte
18	60 74 130	3	Hülse 11x5,5x22	Sleeve	Douille	Casquillo
19	00 18 361	4	Linsenschraube 5x12 mm	Screw	Vis	Tornillo
20	00 18 336	1	Zylinderschraube M5x16 mm	Screw	Vis	Tornillo
21	00 18 275	1	Linsenschraube 5x30 mm	Screw	Vis	Tornillo
22	00 28 157	1	Blechmutter M5	Nut	Écrou	Tuerca
23	60 74 993	1	Chokehebel	Choke lever	Levier choke	Palanca choke
24	60 74 992	1	Halbgasstift	Pin	Boulon	Perno
25	61 00 464	1	Haube enth. (-> 50 - 53	Cover incl. (-> 50 - 53	Couvercle y inclus (-> 50 - 53	Cubierta incl. (-> 50 - 53
26	60 42 827	1	Isolierfolie	Isolating foil	Feuille isolatrice	Laminilla
27	00 68 220	1	Selbstklebeschild "Gehörschutz"	Sticker	Autocollant	Adhesivo
28	00 68 346	1	Selbstklebeschild (-)	Sticker (-)	Autocollant (-)	Adhesivo (-)
29	28 00 646	3	Hauben-Federklammer	Cover clips	Clips de fixation	Pinza de fijación
30	63 00 175 25	1	Druckblech	Pressure plate	Tôle	Chapa de presión
31	00 70 253	1	Druckfeder 1,5x7x21,5	Spring	Ressort	Resorte
32	00 28 150	1	Blechmutter 3,5 mm	Nut	Écrou	Tuerca
33	00 18 340	4	Zylinderschraube M5x40 mm	Screw	Vis	Tornillo
34	00 72 140	4	Scheibe 5,2x12x0,5 mm	Washer	Rondelle	Arandela
35	00 73 439	1	Drehfeder 1,3x6,8	Torsion spring	Ressort	Resorte

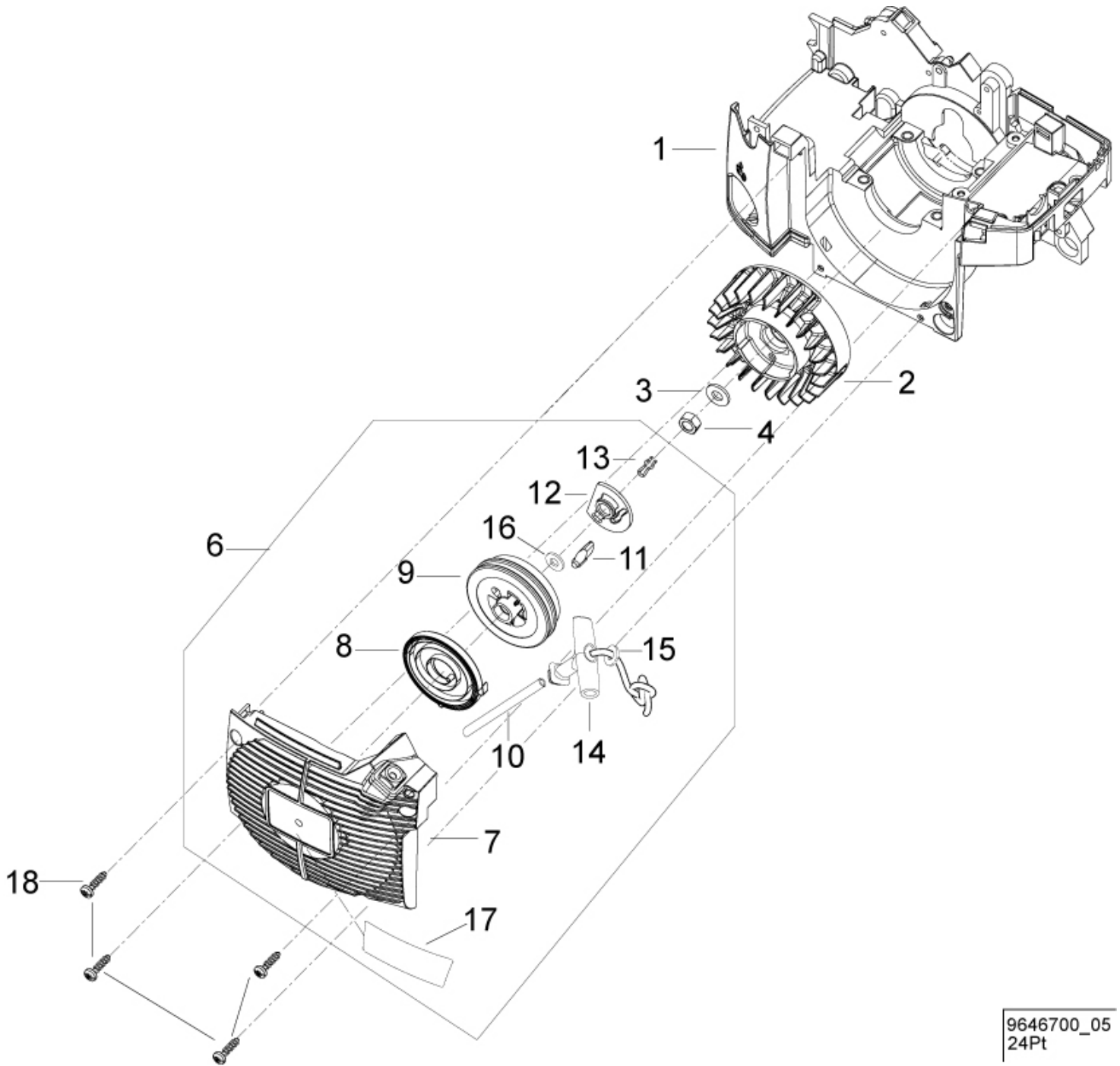

9646700_05
24Pt

Bild-Nr. Pos.-No. No.Pos. Pos.-No.	Bestell-Nr. Order-No. No. de Cde Ref.-Nr.	Menge Quantity Nombres Cantidad	Starter	Starter	Lanceur	Arranque
1	61 00 140	1	Hauptgehäuse	Main housing	Carter principal	Carter principal
2	24 00 318	1	Lüfferrad	Fan wheel	Turbine	Turbina
3	00 72 145	1	Spannscheibe 8 mm	Tension spring	Rondelle de tension	Arandela elastica
4	00 20 145	1	Sechskantmutter M8x1	Nut	Écrou	Tuerca
6	26 00 279	1	Starter kompl. enth. (-> 6 - 17)	Starter compl. incl. (-> 6 - 17)	Lanceur compl. y inclus (-> 6 - 17)	Arranque compl. incl. (-> 6 - 17)
7	21 00 752	1	Startergehäuse	Starter housing	Carter lanceur	Caja de arranque
8	26 00 283	1	Federkassette	Spring cassette	Cassette de ressort	Caja de resorte
9	20 74 419 25	1	Seilrolle	Rope pulley	Poulie de câble	Roldana
10	00 63 186 25	1	Starterseil	Starter rope	Câble de lanceur	Cuerda de arranque
11	20 74 209 25	1	Starterklinke	Starter pawl	Cliquet de lanceur	Trinquete
12	20 74 408 25	1	Kulisse	Template	Coulisse	Colisa
13	00 73 365	1	Federstecker 1,4	Pin	Goupille beta	Clavija
14	20 74 641	1	Startergriff	Starter handle	Poignée de lanceur	Empunadura
15	00 72 148	1	Spannscheibe 4mm	Tension spring	Rondelle de tension	Arandela elastica
16	00 31 260	1	Scheibe 10x 16x0,5 mm	Washer	Rondelle	Arandela
17	00 69 889	1	Selbstklebeschild (-)	Decal (-)	Autocollant (-)	Etiqueta (-)
18	00 18 363	4	Linsenschraube 5x20 mm	Screw	Vis	Tornillo

Griffgehäuse, Haltebügel, Handschutz
Handle bar housing, hand protection
Etrier carter, protégé main
Asa carter, proteccion de mano

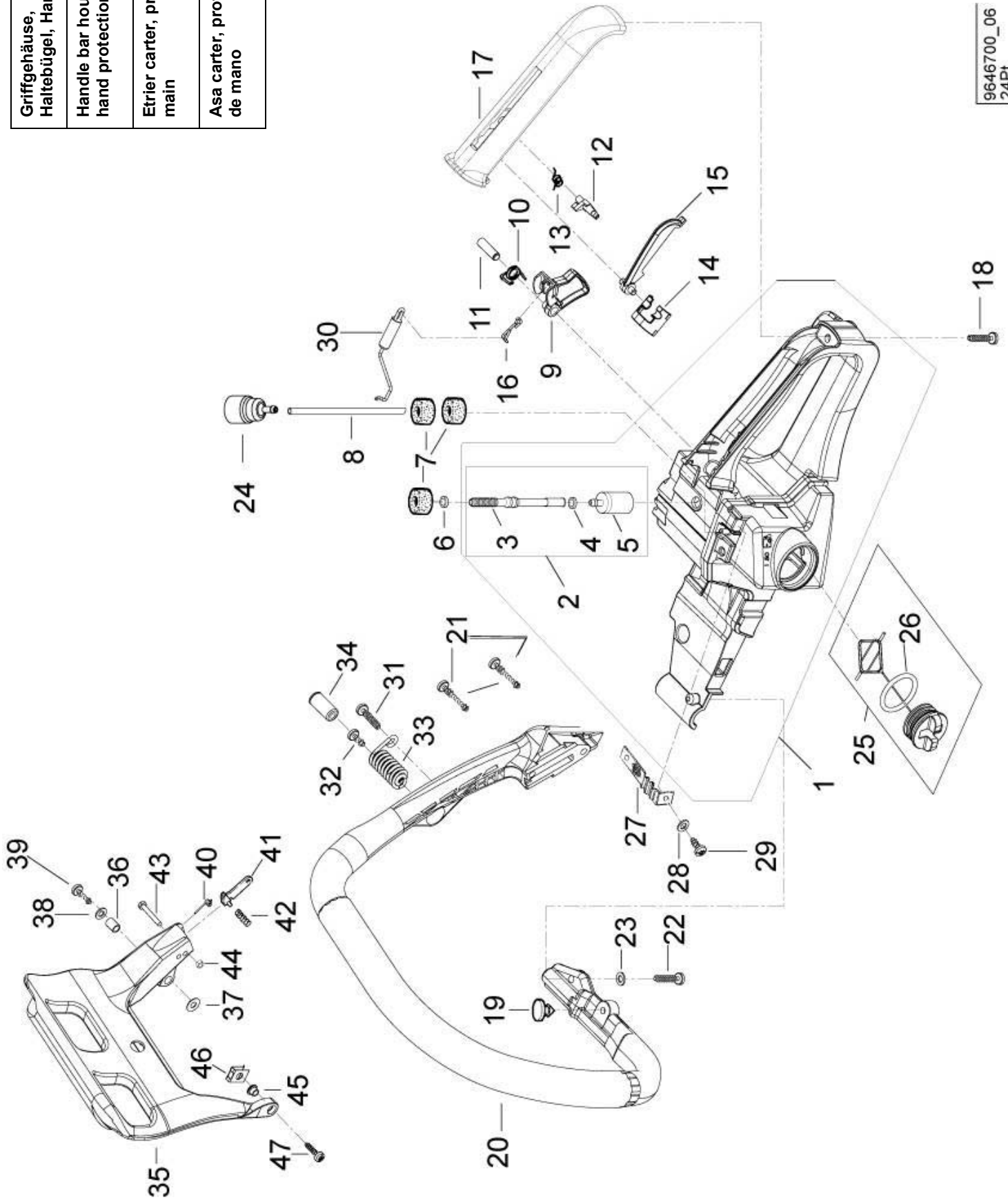

9646700_06
24Pt

Bild-Nr. Pos.-No. Pos.-No.	Bestell-Nr. Order-No. No. de Cde Ref.-Nr.	Menge Quantity Nombres Cantidad	Griffgehäuse, Haltebügel, Handschutz	Handle bar housing, hand protection	Etrier carter, protège main	Asa carter, proteccion de mano
1	61 00 137	1	Griffgehäuse enth. (-> 1- 5	Handle bar housing incl. (-> 1- 5	Etrier carter y inclus (-> 1- 5	Asa carter incl. (-> 1- 5
2	27 00 354	1	Benzinsucher, kompl. enth. (-> 2 - 5	Fuel pick-up, compl. incl. (-> 2 - 5	Crépine d'essence, cpl. y inclus (-> 2 - 5	Busador, compl. incl. (-> 2 - 5
3	60 63 341	1	Kraftstoffschlauch 3x178	Fuel hose	Tuyau	Tube gasolina
4	00 73 351	1	Schlauchhose	Tube eye	Collier	Ojete
5	27 00 135	1	Benzinsucher (->))	Fuel pick-up (->))	Crépine d'essence (->))	Busador (->))
6	00 73 351	1	Schlauchhose	Tube eye	Collier	Ojete
7	60 63 301	3	Schlauchdurchführung	Hose guide	Oeillet	Ojete de tubo
8	00 64 623	1	Schlauch 3x1,5x150mm	Hose	Tuyau	Tube
9	60 74 822	1	Gashebel	Gas lever	Gachette gaz	Acelerator
10	00 73 392	1	Gashebelfeder	Throttle control spring	Ressort de gachette	Resorte acelerador
11	60 74 988	1	Lagerstift 6x21	Pin	Axe de gâchette	Perno
12	60 74 292	1	Blockierhebel	Stop lever	Levier de blocage	Palanca
13	00 73 398	1	Drehfeder 0,7x7,7	Spring	Ressort	Resorte
14	60 74 104	1	Lager Sicherungshebel	Bearing safety lever	Roulement	Cojinete
15	60 74 106	1	Sicherungshebel	Safety lever	Levier de sécurité	Palanca de seguro
16	20 36 412	1	Gasgestänge 2	Throttle linkage 2	Tringlerie des gaz 2	Varillaje de gas 2
17	60 73 112	1	Griffschale	Handle cup	Poignée arrière	Cascara
18	00 18 257	1	Linsenschraube 5x25 mm	Screw	Vis	Tornillo
19	00 94 294	1	Anschlagpuffer	Buffer	Butée	Tope
20	60 74 652	1	Haltebügel	Handle bar	Étrier	Asa
21	00 18 275	2	Linsenschraube 5x30 mm	Screw	Vis	Tornillo
22	00 18 363	1	Linsenschraube 5x20 mm	Screw	Vis	Tornillo
23	00 30 108	1	Scheibe 5,3 mm	Washer	Rondelle	Arandela
24	27 00 414	1	Entlüftungsstutzen	Ventilation socket	Manchon d'aération	Munon
25	27 00 445	1	Tankverschluss, Benzin enth. (-> 25, 26	Tank cap incl. (-> 25, 26	Bouchon réservoir y inclus (-> 25, 26	Tapa de deposito incl. (-> 25, 26
26	00 62 347	1	Dichtung 25x3 mm (->))	Gasket (->))	Joint (->))	Junta (->))
27	00 98 121	1	Fangsicke	Safety catch	Frein	Seguridad
28	00 72 144	1	Sicherungsscheibe 5 mm	Tension washer	Rondelle de tension	Arandela elastica
29	00 18 362	1	Linsenschraube 5x10 mm	Screw	Vis	Tornillo
30	28 00 352	1	Gasgestänge 1	Throttle linkage 1	Tringlerie des gaz 1	Varilla 1
31	00 18 274	1	Linsenschraube 5x16 mm	Screw	Vis	Tornillo
32	00 18 361	1	Linsenschraube 5x12 mm	Screw	Vis	Tornillo
33	00 73 397	1	Dämpfungsfeder 2,5x13,5x33	Spring	Ressort amortisseur	Resorte
34	60 74 130	1	Hülse 11x5,5x22	Sleeve	Douille	Casquillo
35	68 00 239	1	Handschutz	Hand protection	Protège main	Proteccion de mano
36	00 42 306	1	Hülse 7/5,3x9,5	Sleeve	Douille	Casquillo
37	00 72 140	1	Scheibe 5,2x12x0,5 mm	Washer	Rondelle	Arandela
38	00 30 108	1	Scheibe 5,3 mm	Washer	Rondelle	Arandela
39	00 18 257	1	Linsenschraube 5x25 mm	Screw	Vis	Tornillo
40	00 73 439	1	Drehfeder 1,3x6,8	Torsion spring	Ressort	Resorte
41	63 00 175 25	1	Druckblech	Pressure plate	Tôle	Chapa de presión
42	00 70 253	1	Druckfeder 1,5x7x21,5	Spring	Ressort	Resorte
43	60 32 669	1	Sechskantschraube M4x32mm	Screw	Vis	Tornillo
44	00 28 118	1	Sechskantmutter M4	Nut	Écrou	Tuerca
45	00 44 280	1	Rohrniet	Rivet	Rivet	Remache
46	00 28 150	1	Blechmutter 3,5 mm	Nut	Écrou	Tuerca
47	00 18 355	1	Linsenschraube 4x16 mm	Screw	Vis	Tornillo

Schwert, Kette, Anschlagkralle, Kettenspannung
Guide bar, chain, bucking spike, Tension screw / tension carriage
Guide chaîne, chaîne, griffe de butée, Vis de tension
Espada, cadena, garra de apoyo, Tornillo de tension

9646700_07
24Pt



Bild-Nr. Pos.-No. No.Pos. Pos.-No.	Bestell-Nr. Order-No. No. de Cde Ref.-Nr.	Menge Quantity Nombres Cantidad	Schwert, Kette, Anschlagkralle, Kettenspannung	Guide bar, chain, bucking spike, Tension screw / tension carriage	Guide chaîne, chaîne, griffe de butée, Vis de tension	Espada, cadena, garra de apoyo, Tornillo de tension
1	61 00 140	1	Hauptgehäuse enth. (-> 1, 2)	Main housing incl. (-> 1, 2)	Carter principal y inclus (-> 1, 2)	Carter principal incl. (-> 1, 2)
2	00 18 380	2	Stiftschraube M8x18 mm (-)	Screw (-)	Vis (-)	Tornillo (-)
3	00 18 362	2	Linsenschraube 5x10 mm	Screw	Vis	Tornillo
4	60 43 351	1	Anschlagkralle	Bucking spike	Griffe de butée	Garra de apoyo
6	60 31 306	1	Einstellschraube	F. H. Screw	Vis t. c.	Tornillo
7	00 62 174	1	O-Ring	O-ring	Joint torique	Anillo
8	60 31 305	1	Kettenspannschraube	Chain tension screw	Vis de tension	Tornillo de tension
9	00 31 572	1	Scheibe 4 x 8 x 0,5 mm	Washer	Rondelle	Arandela
10	63 00 348	1	Spannschlitten	Tension carriage	Support	Carro
11	60 74 124	1	Getriebeabdeckung	Gear cover	Couvercle de engrenage	Tapa de engranaje
12	60 74 125	1	Lagerung	Support	Support	Soporte
13	00 18 354	1	Linsenschraube 4x12 mm	Screw	Vis	Tornillo
14	60 43 980	1	Kettenführungsblech	Guide plate	Tôle de guidage	Chapa
15	00 13 285	1	Linensblechschraube 3,5x9,5 mm	Screw	Vis	Tornillo
16	60 11 728 25	1	Schwertabdeckung	Chain guard	Carter de chaîne	Cubierta espada
17	60 74 696	2	Gleitschuh	Guide shoe	Patin	Patin
18	00 20 214	2	Sechskantmutter M8	Nut	Écrou	Tuerca
19	00 69 788	1	Selbstklebeschild	Sticker	Autocollant	Adhesivo
20	60 71 258	1	Kettenschutz	Scabrad	Fourreau de chaîne	Proteccion cadena
21	69 00 342		Führungsschiene, .325", 33 cm (13")	Guide bar, .325", 33 cm (13")	Guide, .325", 33 cm (13")	Espada, .325", 33 cm (13")
22	69 00 343		Führungsschiene, .325", 38 cm (15")	Guide bar, .325", 38 cm (15")	Guide, .325", 38 cm (15")	Espada, .325", 38 cm (15")
23	69 00 861		Führungsschiene, .325", 46 cm (18")	Guide bar, .325", 46 cm (18")	Guide, .325", 46 cm (18")	Espada, .325", 46 cm (18")
27	69 00 704		Halbmeiselkette 33 cm (13").325" 56 Treibglieder enth. (-> 30 - 35)	Chain 13" (33 cm) incl. (-> 30 - 35)	Chaîne 13" (33 cm) y inclus (-> 30 - 35)	Cadena 13" (33 cm) incl. (-> 30 - 35)
28	69 00 875		Halbmeiselkette 38 cm (15").325" 64 Treibglieder enth. (-> 30 - 35)	Chain 15" (38 cm) incl. (-> 30 - 35)	Chaîne 15" (38 cm) y inclus (-> 30 - 35)	Cadena 15" (38 cm) incl. (-> 30 - 35)
29	69 00 884		Halbmeiselkette 46cm (18").325" 72 Treibglieder enth. (-> 30 - 35)	Chain 18" (46 cm) incl. (-> 30 - 35)	Chaîne 18" (46 cm) y inclus (-> 30 - 35)	Cadena 18" (46 cm) incl. (-> 211 - 216)
30	05 40 205		Verbindungsglied, ohne Niet	Connection link w/o rivet	Maillon sans rivet	Eslabon de connexion
31	05 40 249		Verbindungsglied mit Niet	Connection link with rivet	Maillon avec rivet	Eslabon con remache
32	05 40 250		Treibglied	Drive link	Maillon entraineur	Eslabon de mango
33	05 40 251		Sicherheitstreibglied	Safety conn.	Maillon de sécurité	Eslabon
34	05 40 203		Linksschneider	Left cutter	Gouge gauche	Cortador izquierda
35	05 40 204		Rechtsschneider (-)	Right cutter (-)	Gouge droite (-)	Cortador derecha (-)

D**Allgemeine Richtlinien für die Bestellung von Original SOLO Ersatzteilen:**

Voraussetzung für eine reibungslose Erledigung sind folgende Angaben:

1. Ersatzteil-Bestellnummer
2. Gewünschte Anzahl
3. Typenbezeichnung des Geräts

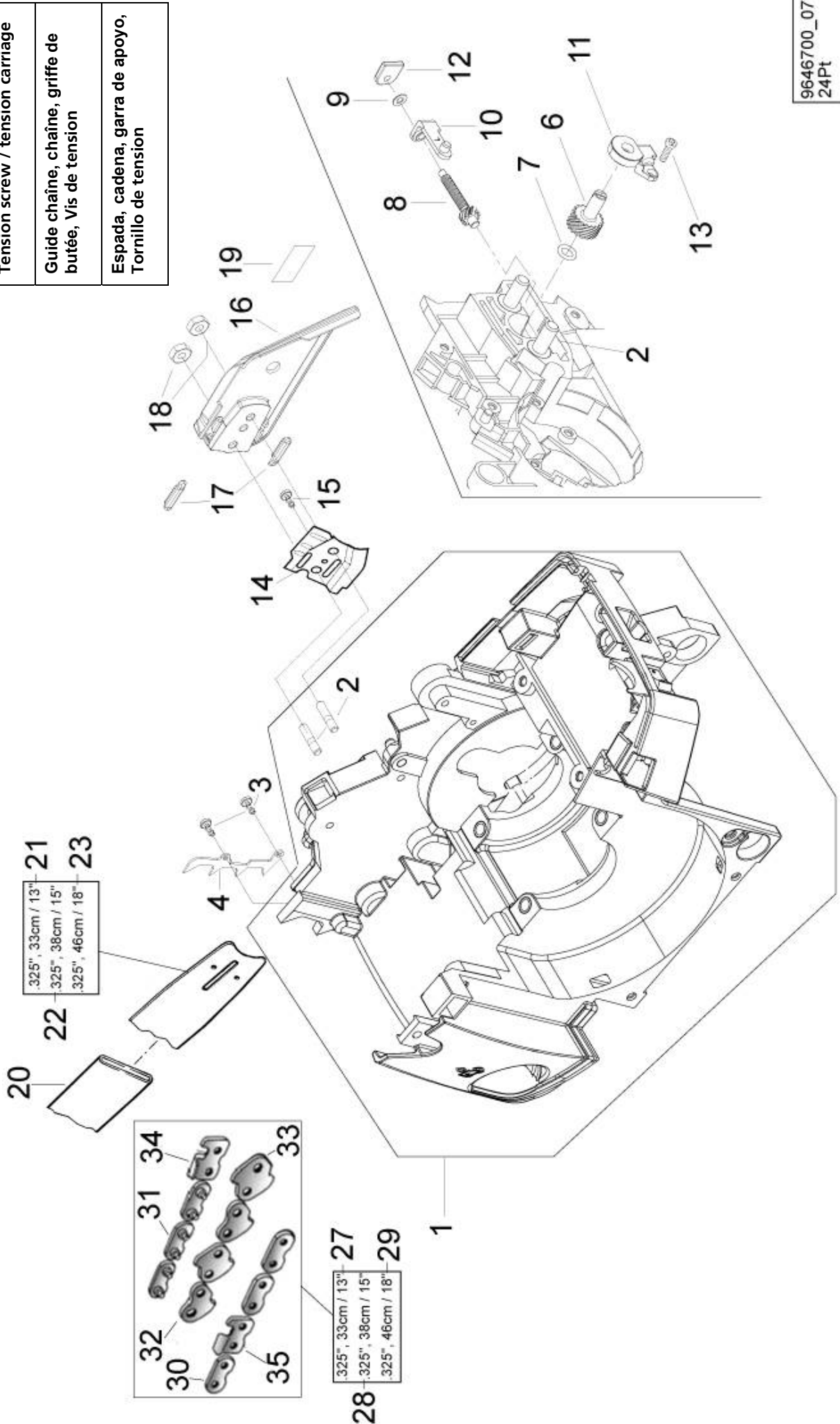
Diese Ersatzteilliste ist für die Lieferung und Ausstattung von SOLO Erzeugnissen unverbindlich. Im Interesse der technischen Weiterentwicklung bleiben Konstruktionsänderungen vorbehalten.

GB**General Directions for Ordering Original SOLO Spare Parts:**

For correct and diligent processing of your order, please give the following information:

1. Spare Part number
2. Quantity
3. Model and serial number
4. Shipping instructions

Delivery is made in accordance with our general sales and delivery conditions. This spare parts list is non-committal for us with regard to delivery and layout of SOLO products. In favour of technical improvements, design modifications are subject to change without notice.

F**Directives générales pour les commandes de pièces de rechange d'origine SOLO:**

Il est indispensable de préciser dans toutes les commandes de pièces:

1. le numéro de référence de la pièce
2. la quantité
3. le type de la machine
4. le mode d'expédition

Les livraisons sont effectuées dans le cadre de nos conditions générales de vente.

Toutes modifications réservées.

E**Directivas Generales de pedido de la firma SOLO:**

Por adelantado de un arreglo sin dificultades necesitamos siguientes indicaciones:

1. Número de repuesto
2. Numero de cantidad
3. Modelo y número de serial
4. Instrucción de Envío

Esta lista de repuestos no es obligatoria para los envíos y/o forma de equipo de los productos SOLO.

En el interés del constante desarrollo debemos reservarnos el derecho de cambios.

Bestell-Nr. Order-No. No. de Cde Ref.-Nr.	Menge Quantity Nombres Cantidad	Seite Page Page Pagina
00 10 574	2	2
00 13 285	1	5
00 13 285	1	10
00 15 301	1	3
00 18 257	1	8
00 18 257	1	8
00 18 274	1	8
00 18 275	1	5
00 18 275	2	8
00 18 336	4	2
00 18 336	1	5
00 18 337	2	2
00 18 337	1	5
00 18 339	1	2
00 18 340	4	5
00 18 354	2	4
00 18 354	3	4
00 18 354	1	10
00 18 355	1	8
00 18 361	4	5
00 18 361	1	8
00 18 362	1	8
00 18 362	2	10
00 18 363	2	3
00 18 363	4	7
00 18 363	1	8
00 18 379	2	3
00 18 380	2	10
00 18 382	2	3
00 20 145	1	2
00 20 145	1	7
00 20 214	2	4
00 20 214	2	10
00 28 118	1	8
00 28 137	3	3
00 28 150	1	5
00 28 150	1	8
00 28 157	1	5
00 28 157	1	5
00 30 101	1	2
00 30 108	1	3
00 30 108	1	8
00 30 108	1	8
00 31 260	1	7
00 31 270	1	4
00 31 529	2	4
00 31 572	1	10
00 34 201	2	3
00 40 188	1	4
00 40 188	1	5
00 42 306	1	8
00 44 280	1	8
00 46 145	1	4
00 46 145	1	5
00 50 102	1	2
00 50 188	1	2

Bestell-Nr. Order-No. No. de Cde Ref.-Nr.	Menge Quantity Nombres Cantidad	Seite Page Page Pagina
00 52 226	1	2
00 52 257	1	4
00 54 220	1	2
00 54 251	1	2
00 55 104	1	4
00 55 136	1	2
00 55 278	2	2
00 62 147	1	5
00 62 174	1	10
00 62 256	1	4
00 62 256	1	5
00 62 276	1	4
00 62 347	1	8
00 63 186 25	1	7
00 64 292	110 mm	2
00 64 319	1	3
00 64 407	35 mm	3
00 64 420	1	3
00 64 623	1	8
00 66 455	1	2
00 68 220	1	5
00 68 346	1	5
00 69 788	1	4
00 69 788	1	10
00 69 841	1	5
00 69 889	1	7
00 70 253	1	4
00 70 253	1	5
00 70 253	1	8
00 70 254	1	4
00 70 265	1	4
00 71 153	2	3
00 72 140	4	5
00 72 140	1	8
00 72 144	6	3
00 72 144	1	8
00 72 145	1	2
00 72 145	1	7
00 72 148	2	2
00 72 148	1	7
00 73 347	1	2
00 73 351	1	8
00 73 351	1	8
00 73 365	1	7
00 73 392	1	8
00 73 397	3	5
00 73 397	1	8
00 73 398	1	8
00 73 439	1	5
00 73 439	1	8
00 84 477	1	5
00 84 621	1	2
00 84 876	1	2
00 84 876	1	5
00 94 294	1	8
00 98 121	1	8

Bestell-Nr. Order-No. No. de Cde Ref.-Nr.	Menge Quantity Nombres Cantidad	Seite Page Page Pagina
05 10 791	1	3
05 40 203		10
05 40 204		10
05 40 205		10
05 40 249		10
05 40 250		10
05 40 251		10
20 11 342	1	2
20 31 117 25	1	2
20 36 412	1	8
20 43 652	1	3
20 48 229	2	2
20 61 476	1	3
20 61 477	1	3
20 61 527	1	2
20 61 528	1	2
20 74 209 25	1	7
20 74 408 25	1	7
20 74 419 25	1	7
20 74 641	1	7
20 74 946	2	3
21 00 752	1	7
21 00 925	1	2
21 00 925	1	4
21 00 930	1	2
22 00 323	1	2
22 00 620	1	2
23 00 724	1	3
23 00 803	1	3
23 00 856	1	2
23 00 888	1	2
24 00 318	1	2
24 00 318	1	7
25 00 665 25	1	3
25 00 688	1	3
25 00 757	1	3
26 00 279	1	7
26 00 283	1	7
27 00 135	1	8
27 00 322	1	3
27 00 326	1	5
27 00 354	1	8
27 00 414	1	8
27 00 441	1	5
27 00 445	1	8
28 00 352	1	3
28 00 352	1	8
28 00 646	3	5
28 00 656	1	2
35 00 362 25	1	4
35 00 405	1	4
60 11 728 25	1	4
60 11 728 25	1	10
60 31 305	1	10
60 31 306	1	10
60 31 996	1	4

Bestell-Nr. Order-No. No. de Cde Ref.-Nr.	Menge Quantity Nombres Cantidad	Seite Page Page Pagina
60 32 669	1	8
60 42 817	1	4
60 42 827	1	5
60 43 351	1	10
60 43 352	1	5
60 43 980	1	5
60 43 980	1	10
60 43 990	1	4
60 63 301	1	3
60 63 301	3	8
60 63 322	1	3
60 63 323	1	4
60 63 329	1	4
60 63 341	1	8
60 71 258	1	10
60 73 112	1	8
60 74 104	1	8
60 74 106	1	8
60 74 124	1	10
60 74 125	1	10
60 74 130	3	5
60 74 130	1	8
60 74 292	1	8
60 74 652	1	8
60 74 696	2	4
60 74 696	2	10
60 74 822	1	8
60 74 976	1	4
60 74 988	1	8
60 74 992	1	5
60 74 993	1	5
60 74 997 25	1	4
60 74 997 25	1	5
60 74 999	1	4
61 00 137	1	8
61 00 140	1	4
61 00 140	1	10
61 00 140	1	7
61 00 464	1	5
62 00 131 25	1	4
63 00 175 25	1	4
63 00 175 25	1	5
63 00 175 25	1	8
63 00 208 25	1	4
63 00 348	1	10
64 00 222	1	4
67 00 124	1	4
68 00 239	1	8
69 00 342		10
69 00 343		10
69 00 704		10
69 00 861		10
69 00 875		10
69 00 884		10