

SOUTH AFRICA
LITHIUM
BATTERIES

LBSA 48V(51.2V) 105AH SMART RACK MOUNT BATTERY

LIFEPO4 BATTERY PACK USER MANUAL

Please read this manual carefully before operating
and retain it for future reference.

This manual introduces LBSA Smart Battery by Lithium Batteries SA. Please read this manual before installation of the battery module and follow the instruction carefully during the assembly. Any confusion, please contact Lithium Batteries SA for advice and clarification.

CONTENT

1. Safety Precautions.....	
1.1 Precautions.....	
1.2 Warning.....	
2. Introduction.....	
2.1 Features.....	
2.2 Specifications.....	
2.3 Interfaces.....	
2.4 Cell Features.....	
2.4.1 Specifications.....	
2.5 Battery Management System.....	
2.5.1 BMS Functions.....	
2.5.2 Compatible Inverters.....	
3. Installation.....	

1. Safety Precautions

This section describes the safety information that must be observed when working with battery packs. To prevent any damages, or personal injury, and to ensure the performance of the battery packs, please read this section carefully and observe the safety precautions at all times.

1.1 Precautions

- It is very important and necessary to read the user manual carefully before installing or using the product. Failure to do so or to follow any of the instructions or warnings in this document can result in electrical shock, serious injury or death, and could damage the battery, or potentially rendering it inoperable.
- If the battery pack is stored for long time, it is required to charge them every six months, and

the SOC should be no less than 90%.

- Please recharged the battery pack within 12 hours, after fully discharged.
- All the battery pack terminals must be disconnected before any maintenance.
- Do not use cleaning solvents to clean battery pack.
- Do not expose battery pack to flammable or harsh chemicals, or corrosive gases or liquids.
- Do not paint any part of battery pack, include any internal or external components.
- Do not expose the battery pack to direct sunlight for extended periods of time.
- Do not connect battery pack with PV solar wiring directly.
- Do not insert any foreign object into any part of the battery pack.

1.2 Warning

- Do not touch the battery pack with wet hands.
- Do not crush, drop or puncture the battery pack.
- Always dispose of the battery pack according to local safety regulations.
- Store and recharge the battery pack in a manner in accordance with this user manual.
- Ensure reliable grounding.
- Do not reverse the polarity when installing.
- Do not short circuit the terminals, remove all jewellery items that could cause a short circuit before installation and handling.
- Disconnect battery from power or loads, and then power off battery before installation and maintenance.
- The battery packs should be not stacked more than specified numbers.
- Continued operation of a damaged battery pack can result in a fire.

2. Introduction



LBSA lithium iron phosphate battery pack is a household renewable energy storage solution developed and produced by Lithium Batteries SA. After fully installation, it is a low-voltage DC battery system with an operating voltage of 51.2V, and works with a low voltage inverter to realize the goal of energy storage for home application.

The battery pack supports parallel connection to expand capacity, which can meet various capacity requirements. It has built-in battery management system (BMS), which can manage and monitor the pack and cells information including voltage, current and temperature. What's more, BMS can balance cells charging and discharging to extend cycle life.

2.1 Features

- Battery cell is 3.2V 105Ah aluminium case prismatic cell.
- Battery cell is made from lithium iron phosphate (LiFePO₄) with safety performance and longer cycle life.
- BMS has over-discharge, over-charge, over-current, high and low temperature warning and protection functions.
- BMS monitors charge and discharge state, and balance current and voltage of each cell.
- Flexible configuration, max. 16 packs can be connected in parallel for expanding capacity and power with 8 DIP switches.
- Working temperature range is from -20°C~50°C (Charging 0°C~50°C; discharging -20°C~50°C) with excellent discharge performance and cycle life.

2.2 Specifications

Basic Parameters	
Nominal Voltage (V)	51.2V V
Nominal Capacity (Ah)	105Ah(>105Ah)

Nominal Power (Wh)	> 5.2KWh @ 0.4c (tested)
Dimension (mm)	477*423*176mm
Weight (Kg)	49KG
Discharge Cut-off Voltage (V)	44V
Charge Voltage (Bulk + Absorption) (V)	56V
Max. Discharge Current (A)	100A
Recommended Charge Current	50A
Communication Interface	CAN
Configuration	16S
Working Temperature	0~50°C (Charge)
	-20~50°C (Discharge)
	-20~55°C (Storage)
Cell chemistry	Lithium iron phosphate (LiFePO4)
Cycle life	≥80% capacity state after 4800 cycles at 0.5C, 25°C, 100% DOD
IP level	IP 20

2.3 Interfaces

RESET

Reset button: to start the battery pack, hold the button for 2s to turn on battery pack.

RS485

RS485 communication interface: RJ45 port, follow RS485 protocol. For transmitting battery pack information between paralleled packs.

Use a standard RJ45 cable.

Pin	Definition
PIN 1, 8	RS485-B
PIN 2, 7	RS485-A
PIN 3, 6	Ground
PIN 4,5	NC (Bridge weld)

CAN

CAN communication interface: follow CAN BUS protocol, for output pack information to inverter.

RJ-45 CAN BUS PINOUT

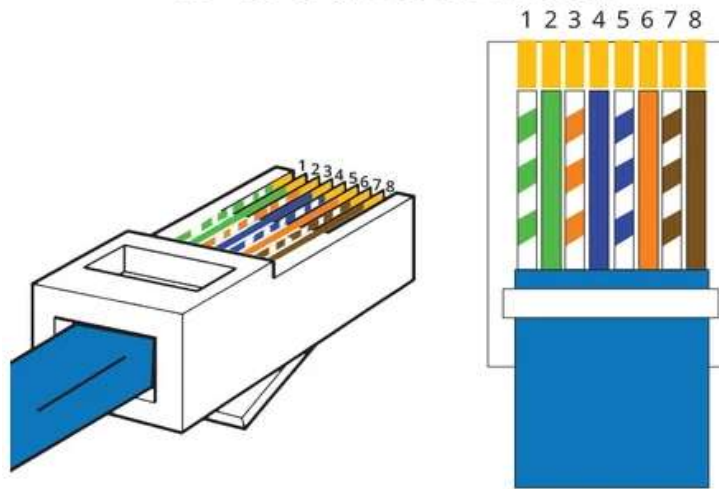

Pin 3:

Pin 4:

Pin 5:

Ground

CAN-H

CAN-L

ADDRESS

ADS Switch: To setup battery address, and to communicate between battery and Inverter.

NOTE: There are 8-bit DIP switches, keep the switch on down side means 'OFF', turn up the switch to top side means 'ON'.

CAN communication DIP address should setup as the following table.

CAN Communication									
Master Packs (#1, #2, #3, #4 set OFF) #5, #6, #7, #8 set as follows					Slave Packs (#5, #6, #7, #8 set OFF) #1, #2, #3, #4 set as follows				
	8	7	6	5		4	3	2	1
One pack	OFF	OFF	OFF	OFF					
2 packs in parallel	OFF	OFF	OFF	ON	1 st slave pack	OFF	OFF	OFF	ON
3 packs in parallel	OFF	OFF	ON	OFF	2 nd slave pack	OFF	OFF	ON	OFF
4 packs in parallel	OFF	OFF	ON	ON	3 rd slave pack	OFF	OFF	ON	ON
5 packs in parallel	OFF	ON	OFF	OFF	4 th slave pack	OFF	ON	OFF	OFF
6 packs in parallel	OFF	ON	OFF	ON	5 th slave pack	OFF	ON	OFF	ON
7 packs in parallel	OFF	ON	ON	OFF	6 th slave pack	OFF	ON	ON	OFF
8 packs in parallel	OFF	ON	ON	ON	7 th slave pack	OFF	ON	ON	ON
9 packs in parallel	ON	OFF	OFF	OFF	8 th slave pack	ON	OFF	OFF	OFF
10 packs in parallel	ON	OFF	OFF	ON	9 th slave pack	ON	OFF	OFF	ON
11 packs in parallel	ON	OFF	ON	OFF	10 th slave pack	ON	OFF	ON	OFF
12 packs in parallel	ON	OFF	ON	ON	11 th slave pack	ON	OFF	ON	ON
13 packs in parallel	ON	ON	OFF	OFF	12 th slave pack	ON	ON	OFF	OFF
14 packs in parallel	ON	ON	OFF	ON	13 th slave pack	ON	ON	OFF	ON
15 packs in parallel	ON	ON	ON	OFF	14 th slave pack	ON	ON	ON	OFF
16 packs in parallel	ON	ON	ON	ON	15 th slave pack	ON	ON	ON	ON

ALARM

ALARM light: red LED flash to show the battery alarm status.

And red light permanently to show the battery in protection status of abnormal temperature, over-current, or short-circuit.

RUN

Working light: green LED to show the battery working status.

Details as follows,

Battery status	Operating Mode	RUN	ALM	LED Light				Remark
		●	●	●	●	●	●	
Power off	Standby	OFF	OFF	OFF	OFF	OFF	OFF	OFF
Standby	Normal	Solid Green	OFF	According to battery SOC status				Standby mode
Charge Mode	Normal	Solid Green	OFF	According to battery SOC status				
	Over current warnings	Solid Green	Blink type 2	According to battery SOC status				
	Over voltage protection	Blink type1	OFF	OFF	OFF	OFF	OFF	
	Temperature, over current protection	Blink type1	OFF	OFF	OFF	OFF	OFF	
Discharge Mode	Normal	Blink type 3	OFF	According to battery SOC status				
	Warning	Blink type 3	Blink type 3	According to battery SOC status				
	Over current, temperature, short-circuit protection	OFF	Solid Red	OFF	OFF	OFF	OFF	Termination of discharge
	Under voltage protection	OFF	OFF	OFF	OFF	OFF	OFF	Termination of discharge

CAPACITY

SOC light: 4 green LED lights to show the capacity status of battery pack. Each LED represents 25%

the capacity.

Status	Charge				Discharge			
Capacity indicator	● L4	● L3	● L2	● L1	● L4	● L3	● L2	● L1
0-25%	OFF	OFF	OFF	Blink	OFF	OFF	OFF	Solid Green
25%-50%	OFF	OFF	Blink	Solid Green	OFF	OFF	Solid Green	Solid Green
50%-75%	OFF	Blink	Solid Green	Solid Green	OFF	Solid Green	Solid Green	Solid Green
>75%	Blink	Solid Green	Solid Green	Solid Green	Solid Green	Solid Green	Solid Green	Solid Green
Operating indicator	Solid Green				Blink			

P+/P-

Power terminals: one pairs of power terminals to go directly to a single inverter if one pack is used. If more than one pack is used the batteries must be connected to a busbar with equal length cable to ensure there is equal discharge and charge between the batteries

2.4 Cell Features

2.4.1 Specifications

GFB 3.2V 100Ah lithium iron phosphate (LiFePO4) aluminium case prismatic rechargeable battery cell.

	Nominal Voltage	3.2V
	Nominal Capacity	105Ah
	Weight	≤2.25Kg
	Self-discharge Rate	≤3.5% per month
	Initial Internal Resistance (1KHz)	≤0.35mΩ

Refer to the cell specification for more detailed information.

High quality Grade A cells are inside the battery box

Judging by the current testing report below, if the battery pack charging and discharging at 0.2C, the battery pack could reach a cycle life of 6000 times or more at the remaining capacity of 80% capacity state at 25°C room temperature, 100%DOD.

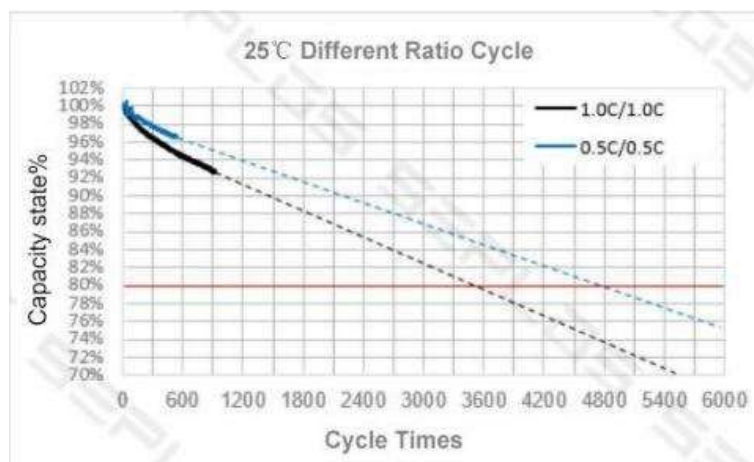

- The real capacity of each single cell is 105Ah.
- The module inside comes with 16 cells in series.

2.5 Advanced Battery Management System (BMS) inside

The BMS is applied to monitor current, voltage, temperature, protection against over-charge, over-discharge, over-current, over-temperature, under-temperature and short circuit. The BMS provides cell balancing and current limitation during charging process to ensure a reliable safety and performance.

The BMS will automatically adjust the Available capacity after every full charge of 56v when discharge.

This capacity will be influenced by the Temperature as the cells generally have less capacity available under very cold temperatures.

2.5.1 BMS Functions

- Over charge protection
- Over discharge protection
- Over current protection
- Cell balancing
- Temperature protection
- CAN communication to inverters and RS485 communication between battery packs

2.5.2 Compatible Inverters (with regards to CANbus Communication), all other inverters should have the charge and discharge cut-off set with accordance to section 2.2 on the Manual

- Victron
- Growatt (Straight RJ45 cable to be used between the battery and inverter.)
- Goodwe (Straight RJ45 cable to be used between the battery and inverter.)
- Sunsink (Straight RJ45 cable to be used between the battery and inverter.)

- Deye(Straight RJ45 cable to be used between the battery and inverter.)

3. Installation

The Battery can be rack mounted with the brackets supplied.

The contactor plug is a pressure plug rated for 100a and takes a 25mm² cable, a hydraulic crimper will be required to crimp the wire into the plug.

When connecting the batteries in Parallel the batteries should be connected to a central Busbar and from the busbar be distributed to the inverters with equal cable lengths.

Please note that installation cables and communication cables are not included.

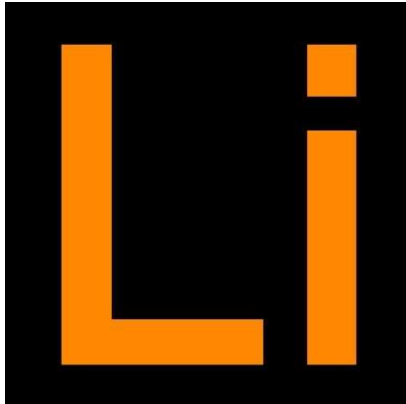

SOUTH AFRICA
LITHIUM
BATTERIES

This document is subject to change without notice.

©2021 Lithium Batteries SA
617 Maretsel PI, Wychwood
Unit 9, The Gables Commercial Park
Johannesburg, 1401 TEL: (+27) 10 110 1991
mail: info@lbsa.co.za
<http://www.lbsa.co.za>