



World's First Portable, Remote-Control Aircraft Tugs

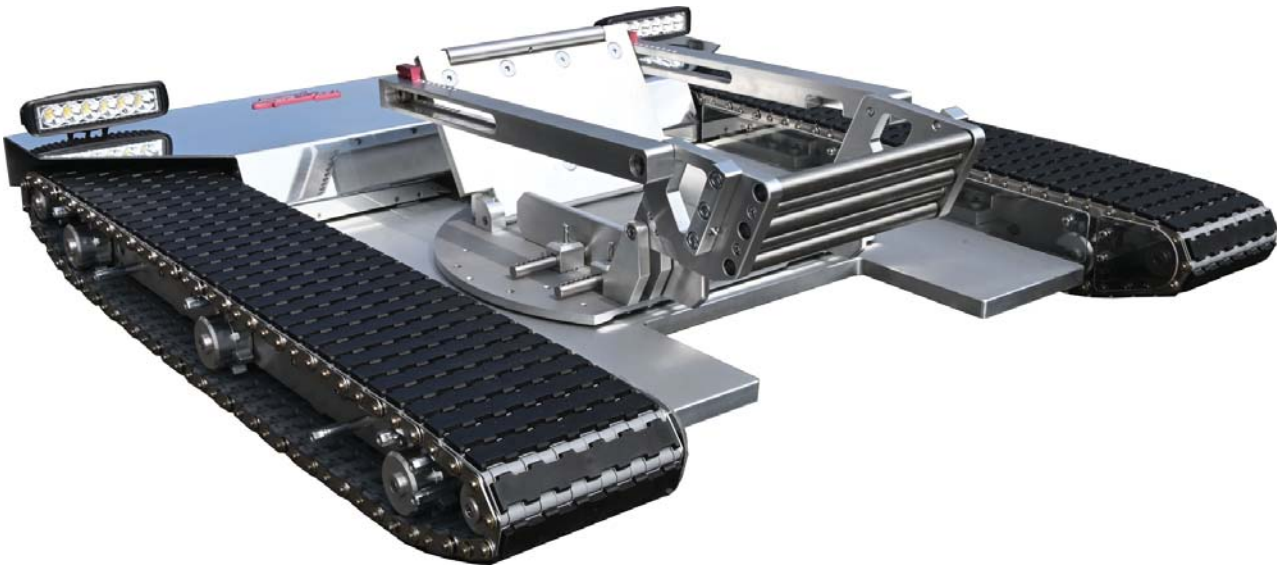
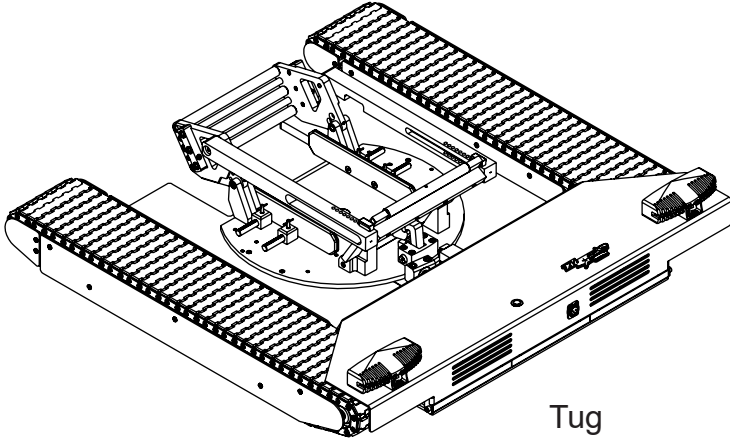

Table of Contents

1. Components	3
1-1 Components in the Box	3
1-2 Tug Components	4
1-3 Remote Control Components	5
1-4 Charger Components	6
1-5 Spare Parts	7
1-6 Track Tools	8
1-7 On-Board Parts Box	10
2. Start-Up Guide	11
2-1 Remote Control Operation	11
2-2 Operating the Tug	12
2-3 Loading the Aircraft Wheel	14
2-4 Unloading the Aircraft Wheel	17
2-5 Adjusting the Wheel Cradle	20
2-6 Adjusting the Tire Guide Spacers	22
2-7 Adjusting Track Tension	24
2-8 Lifting the Wheel Cradle Ramp	26
2-9 Charging the Tug	28
2-10 Charging the Remote Controller	29
2-11 Replacing the Remote Control Batteries	30
3. Troubleshooting	32
4. Warranty	37

1. Components

1-1 Components in the Box



Tug

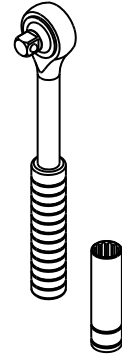

Track Adjustment Tools

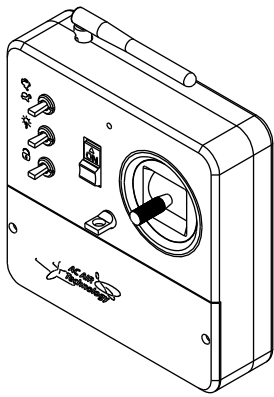

Radio Transmitter

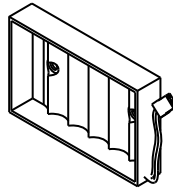

Battery Tray

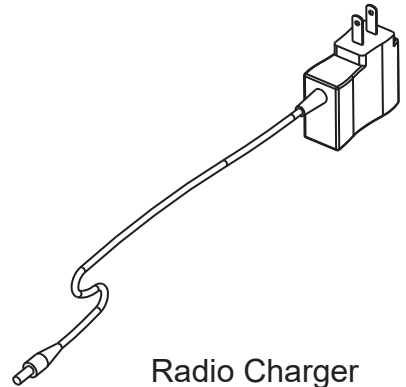

Radio Charger

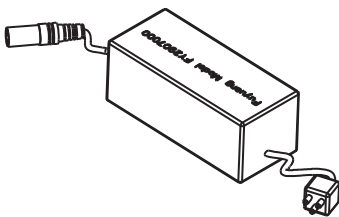

Tug Charger

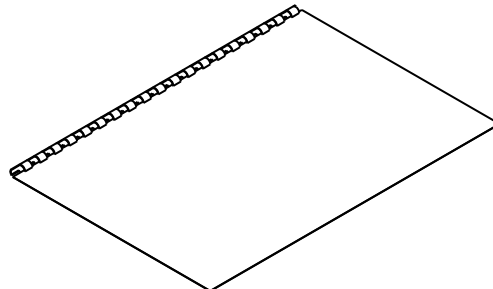

Owners Manual

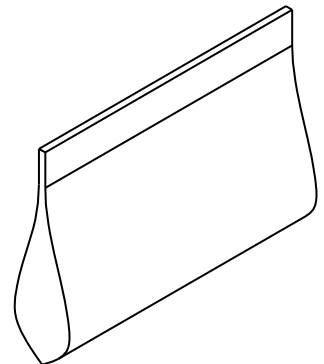

Spare Parts Bag

1. Components

1-2 Tug Components

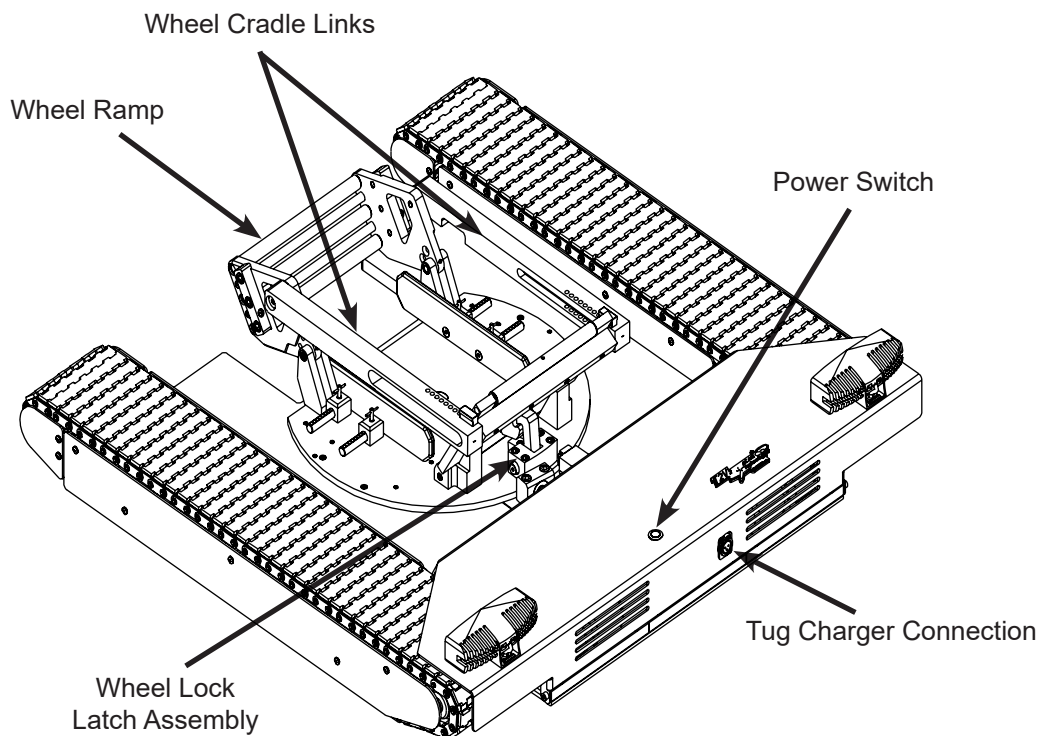
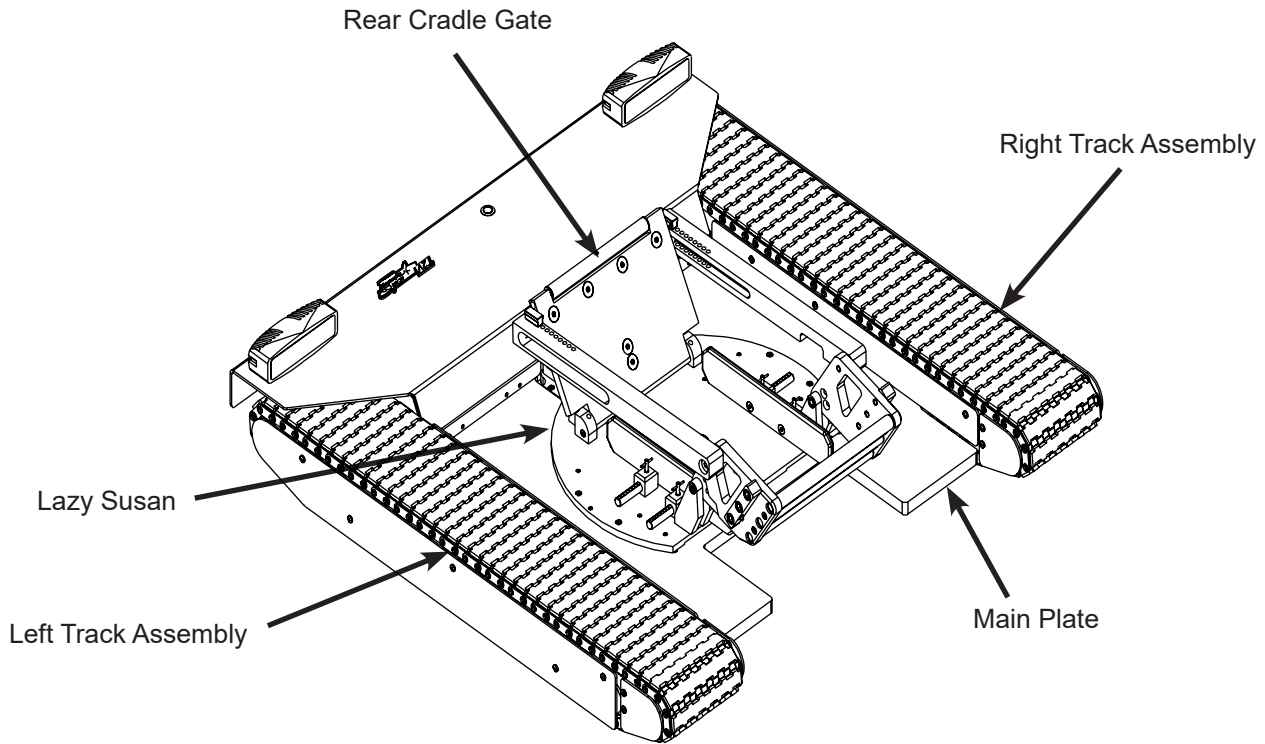

1. Components

1-3 Remote Control Components

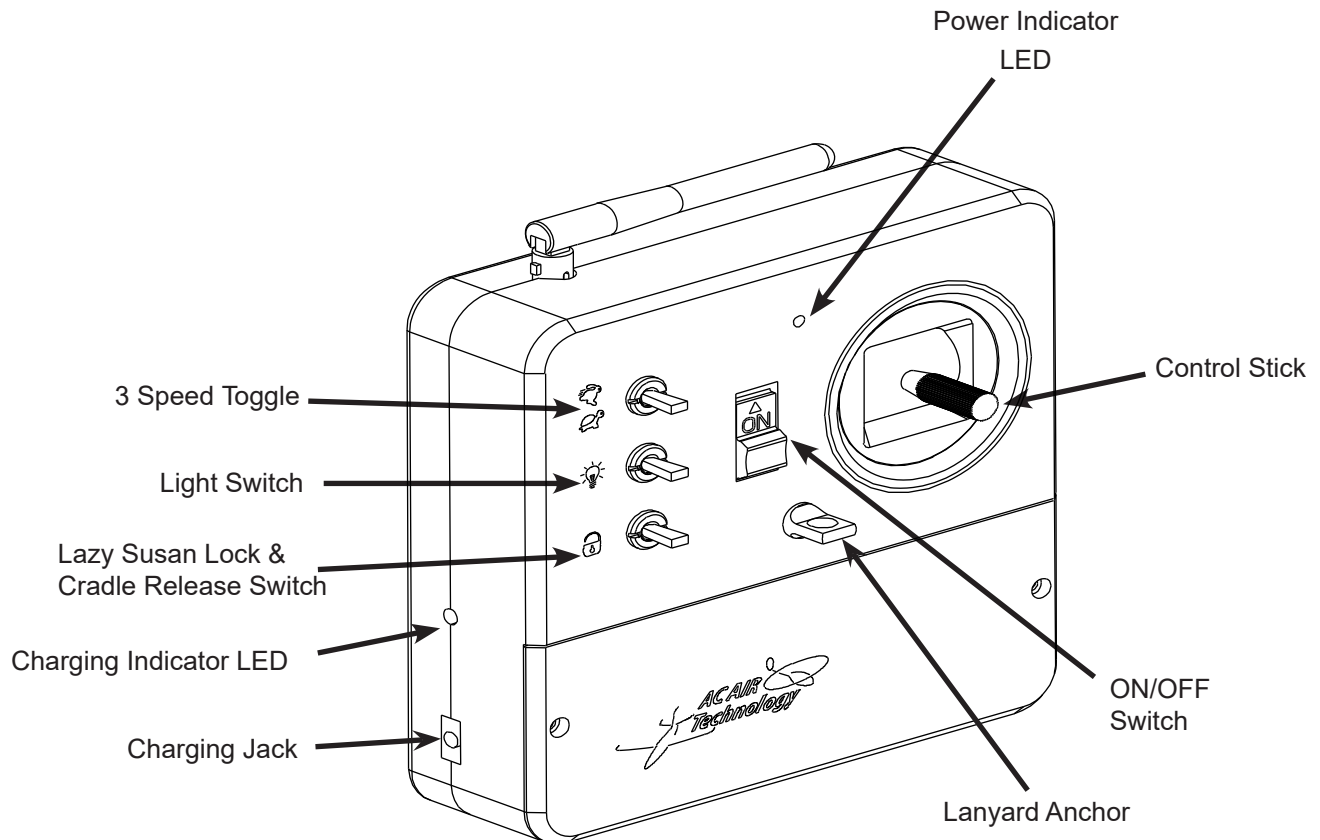

Warning: The control stick on the remote controller is very sensitive and will cause the tug to move if it is moved accidentally. Turn OFF the remote controller when not in use.

Note: If the remote controller is not used for a few minutes it will start beeping as a indicator that it is still in the ON position. This is not an indicator of a low battery.

1. Components

1-4 Charger Components

Tug Charger

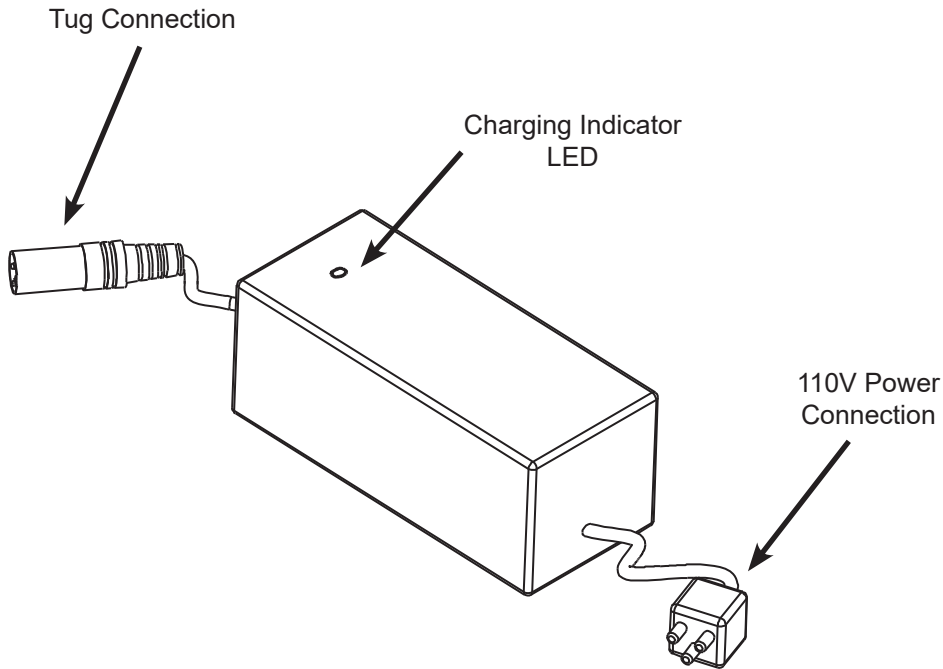

Radio Charger

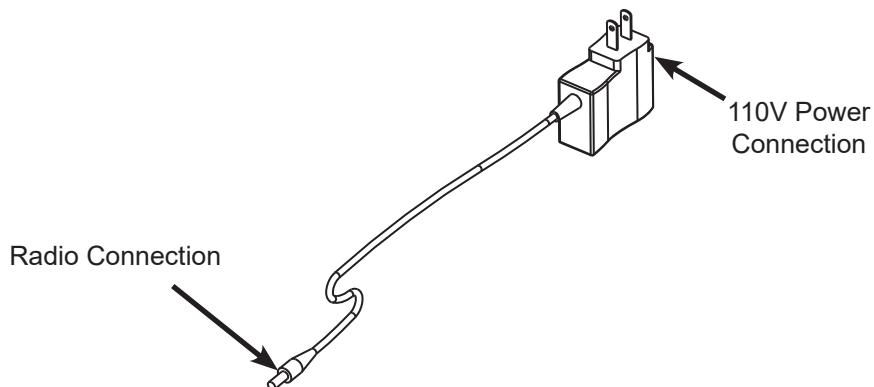

1. Components

1-5 Spare Parts

Spare Track Parts

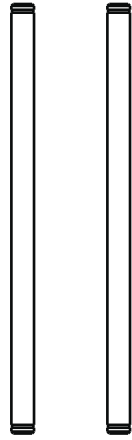

Pins



Retainer Clips

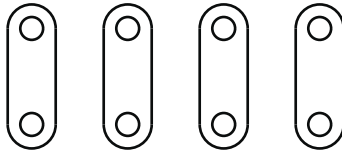

Links

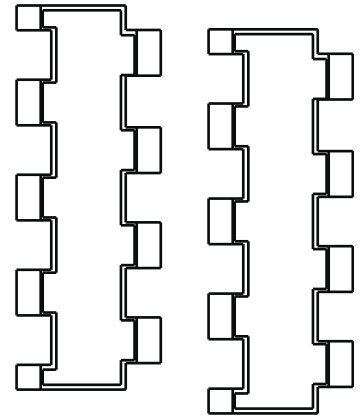

Treads

Track Install Tools

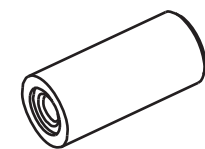
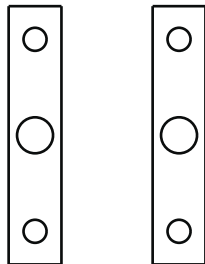

Retainer Clip Tool

Fuses

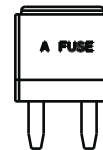

4 Amp Light Fuse

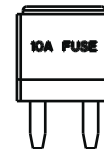

10 Amp Circuit Board Fuse

1. Components

1-6 Track Tools

The track tools are used to assist in the installation of new tracks.

This section is intended to show how the tools are used only. A detailed instruction guide is provided when purchasing new tracks. Refer to that instruction guide when installing new tracks.

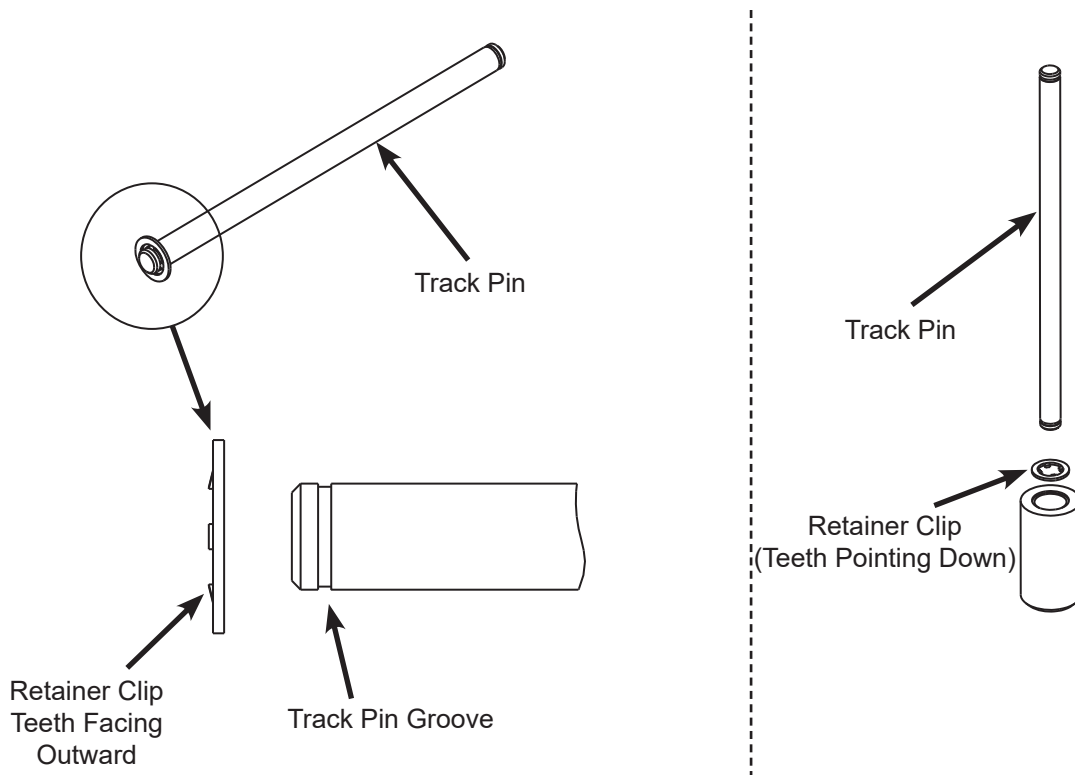

When the retainer clip is properly installed into the track pin groove it should rotate freely inside of the groove.

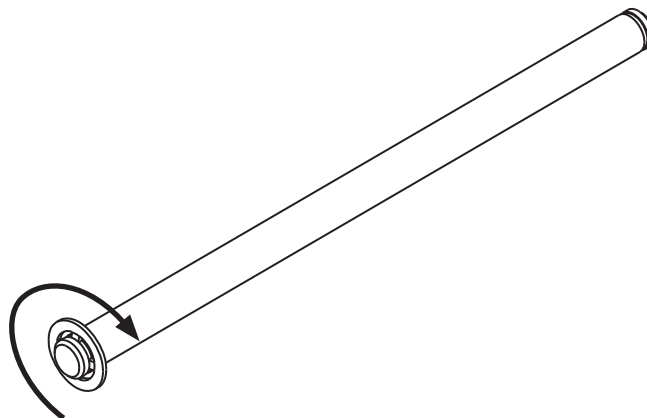

The Track Pin Tools are used to assist in the installation of new tracks when the they are too tight making it difficult to align the pin holes.

Insert the track pin tools on the inside and outside adjacent pins to the missing pin hole. You will need to hold these in place by hand.

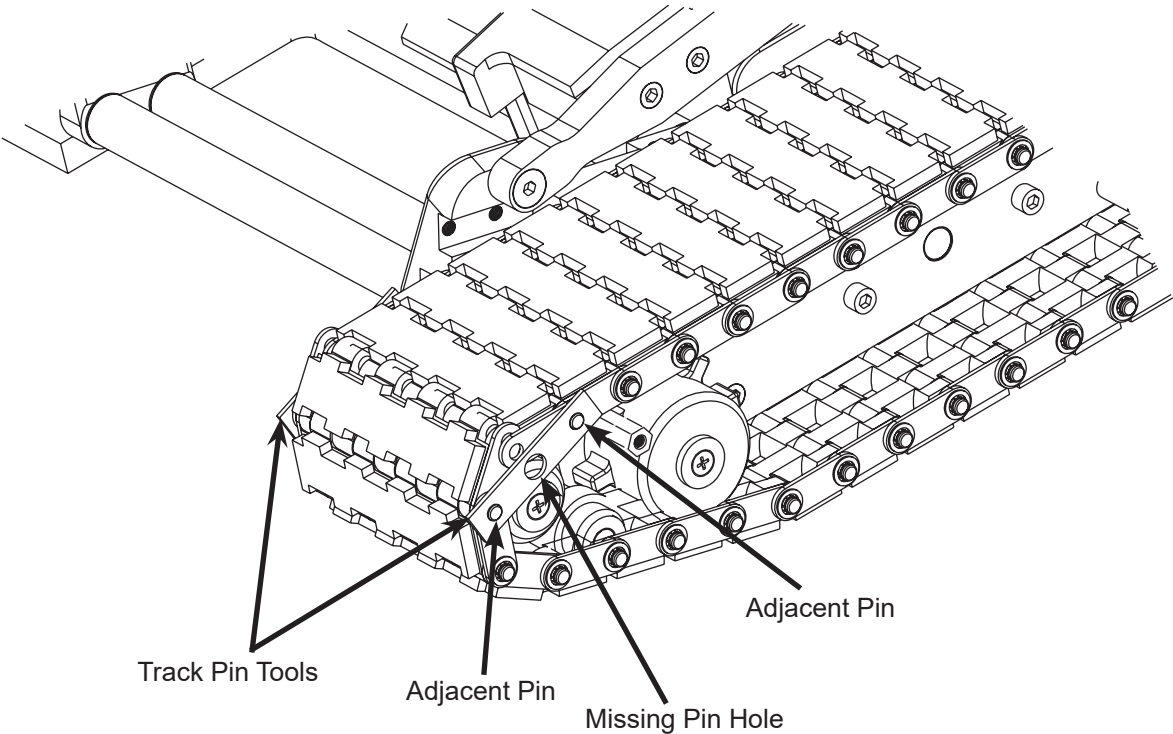

1. Components

1-7 On-Board Parts Box

The On-Board Parts Box contains spare track links / shims, rotoclips, and a rotoclip tool to quickly replace or repair tracks. It also includes cradle shim mounting screws to lift the wheel cradle ramp away from the ground. When the ground is very uneven the wheel cradle ramp may hit the ground preventing the aircraft from loading. These components are located on-board the tug, underneath the electronics cover.

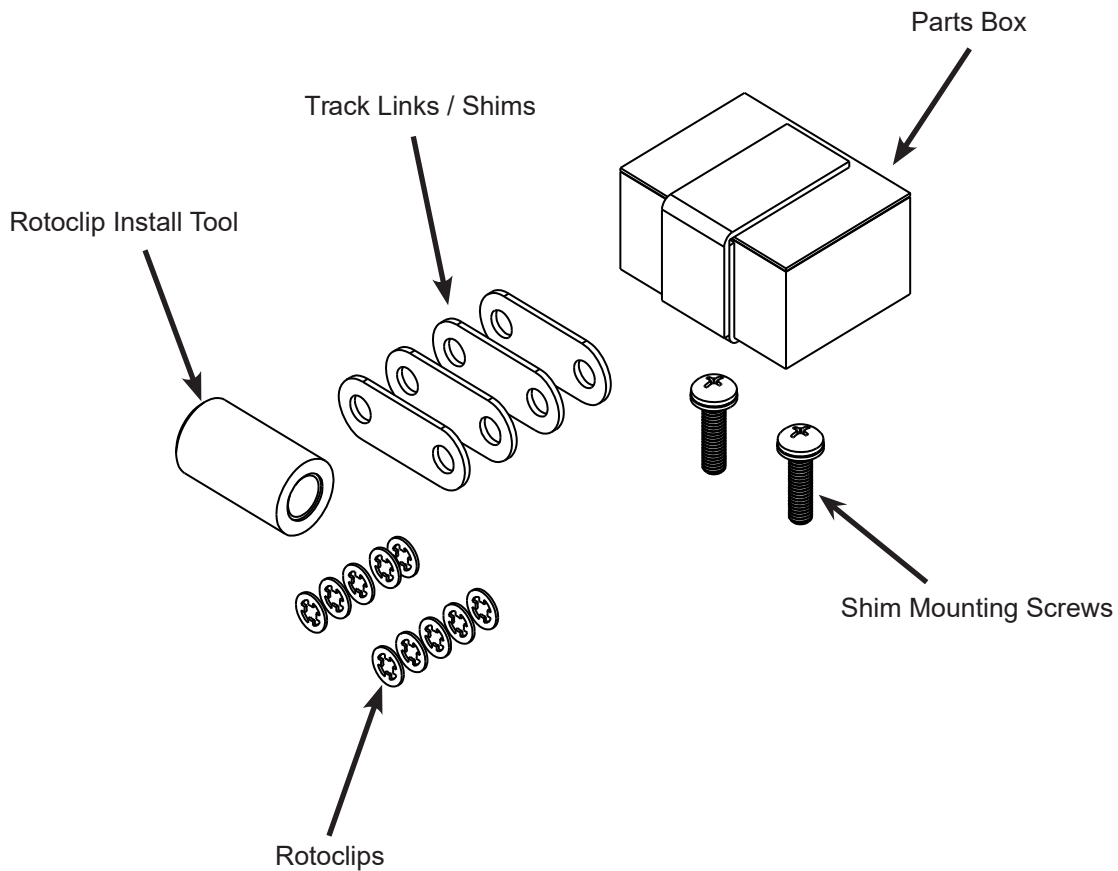

2. Start-Up Guide

2-1 Remote Control Operation

1. Switch the remote control ON. The power indicator light turns on and the remote control beeps once. If this does not happen, check the remote control battery connection for proper installation. When the battery level is low, the remote control will begin to beep repeatedly, signaling to replace or recharge the batteries.
2. To drive the tug, move the control stick in the desired direction.
3. The Lazy Susan Lock & Cradle Release Switch is a 3 position switch. The Unlock and Lock positions are used to lock the lazy susan rotation. The Release position is to release the tire from the cradle while unloading.

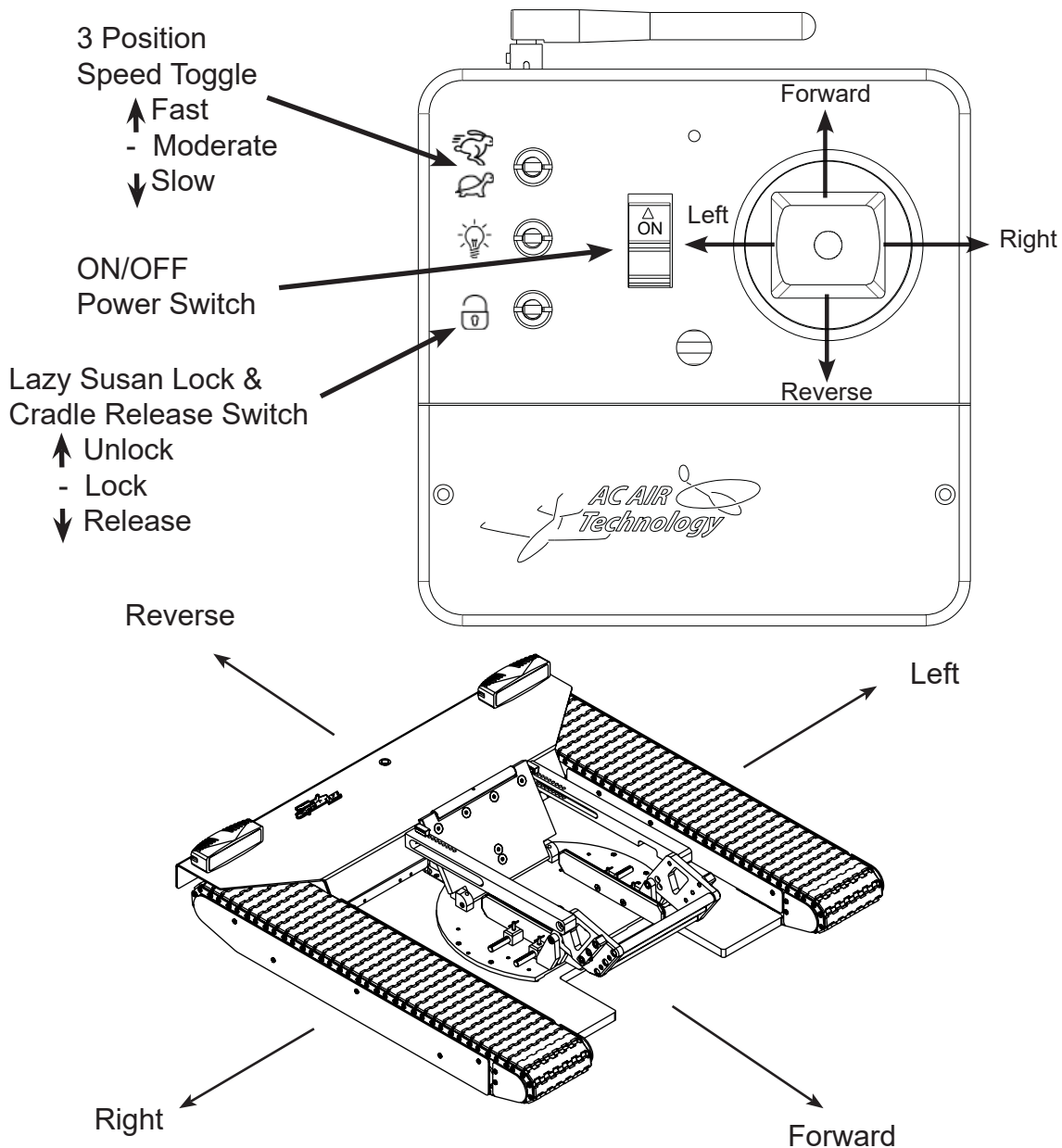

2. Start-Up Guide

2-2 Operating the Tug

1. Before turning on the tug, make sure the tracks and bottom of the tug are free from obstruction.
2. Turn the tug on using the ON/OFF switch. There will be a short series of beeps and then the ON/OFF switch will illuminate red to show the tug is on. The ON/OFF switch light will be on solid when the battery is fully charged. When the tug battery is low the ON/OFF switch light will blink and there will also be a beeping sound.

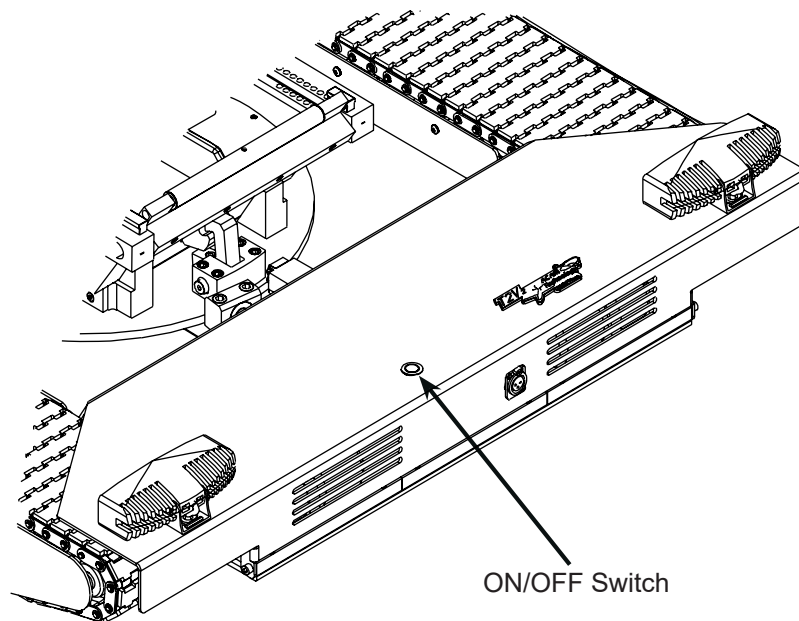

3. Turn on the power switch on the radio controller. The power indicator LED will illuminate green/blue in color. **It is recommended you practice maneuvering the tug prior to loading the plane.**
4. It is recommended to use the radio in fast speed mode. Moderate and Slow speed mode should be used when maneuvering in tight quarters as it reduces the tugs power output.
5. When towing your airplane ALWAYS be cautious of the steering angle limitations of your aircraft. Do not over steer your aircraft with the tug. This can cause damage to your gear.

6. After lifting the tug off of the ground for any reason or taking it in and out of your aircraft, you must check the sprockets for proper seating along the tracks. If the sprocket is not properly seated it could result in damage to the track.

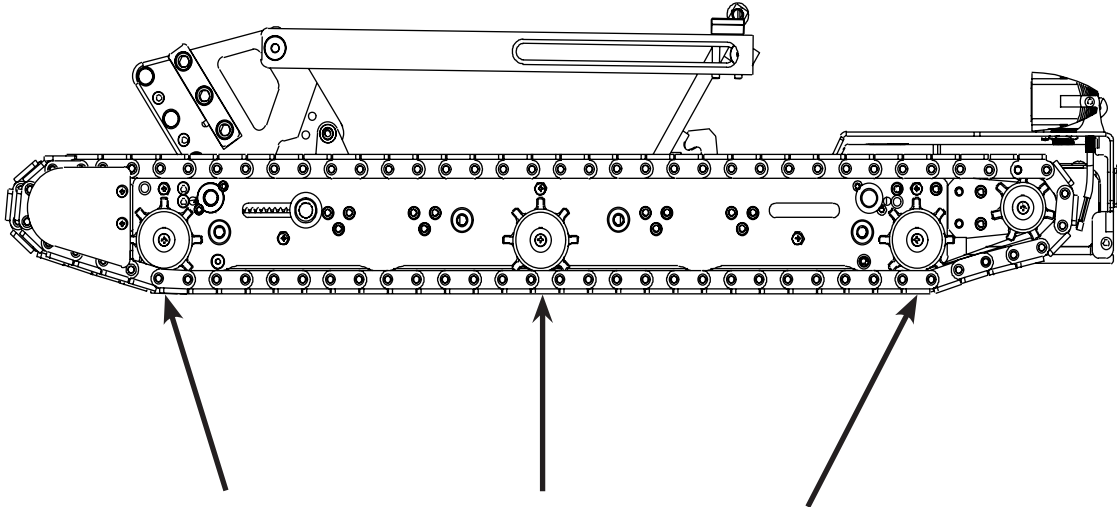

Check sprockets for proper seating and alignment.

7. Visually check tracks for wear on the treads and wear on the inner plastic surfaces. Also inspect for damaged or missing retainer clips as a result of driving over small rocks. Damaged treads should be replaced before operating the tug.

2. Start-Up Guide

2-3 Loading the Aircraft Wheel

WARNING:

DO NOT SIT IN THE PLANE WHILE DRIVING THE TUG.

TO PREVENT GOING BEYOND YOUR STEERING LIMITS IT IS HIGHLY RECOMMENDED THAT YOU LOCK THE LAZY SUSAN FROM ROTATING WHILE GOING UP AND DOWN HILLS AND MOVING ALONG A STRAIGHT PATH. THE LAZY SUSAN FEATURE SHOULD ONLY BE USED ON FLAT GROUND AND WHEN MANEUVERING IN TIGHT QUARTERS.

1. Once the pre-load setup is complete turn ON the tug power switch and remote controller power switch. The wheel ramp needs to be in the down position before loading the aircraft wheel. If the wheel ramp is in the up position then hold the latch release switch on the radio controller and slowly rotate the lazy susan with the controller until the latch releases the ramp and it falls to the down position. The ramp release only occurs when the lazy susan is oriented with the wheel ramp facing forward. Once the wheel ramp is in the down position toggle the latch release switch to the middle position, locking the lazy susan from rotating.

WARNING:

DO NOT PUT ANY PART OF YOUR BODY IN THE MECHANISM WHILE RELEASING THE LATCH. SEVERE BODILY INJURY CAN OCCUR.

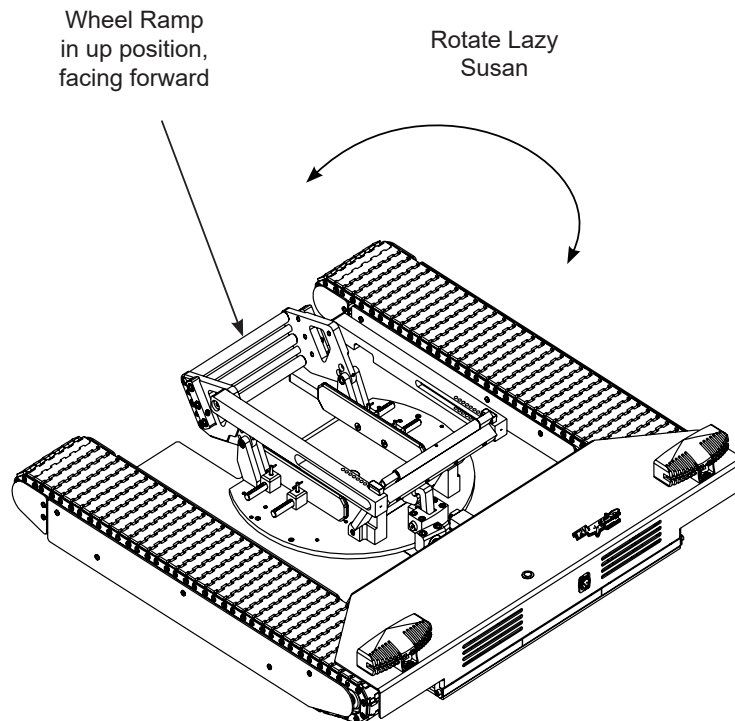

2. Drive the tug to line up the aircraft tire with the center of the wheel ramp.

It may be necessary to apply a little pressure with your foot to the top of the battery cover to get the wheel started onto the tug.

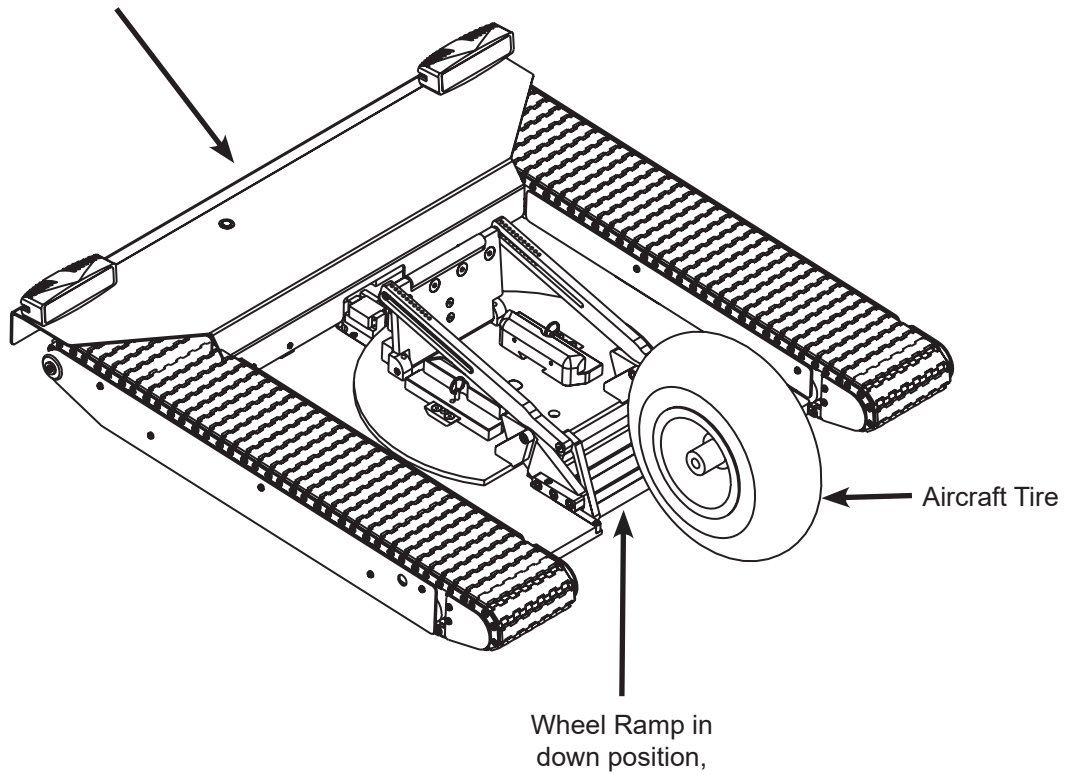

3. Drive the tug under the aircraft tire until the tire is positioned on top of the lazy susan. It may be necessary to chock the wheels to keep the plane from moving.

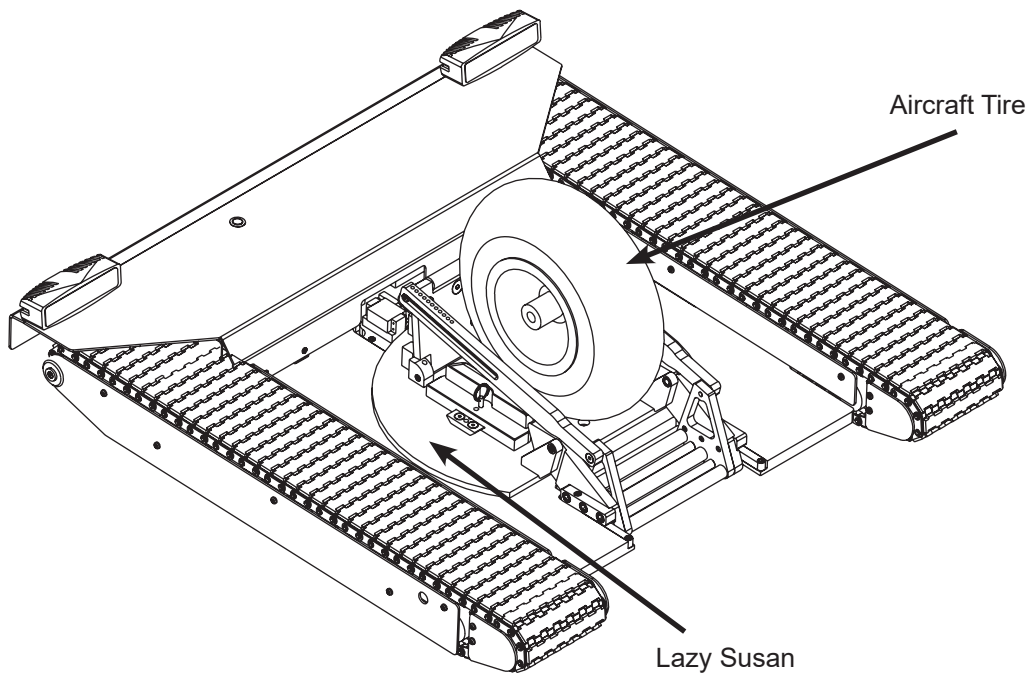

4. Continue driving the tug under the tire until the rear gate locks onto the latch and the wheel ramp is in the up position.

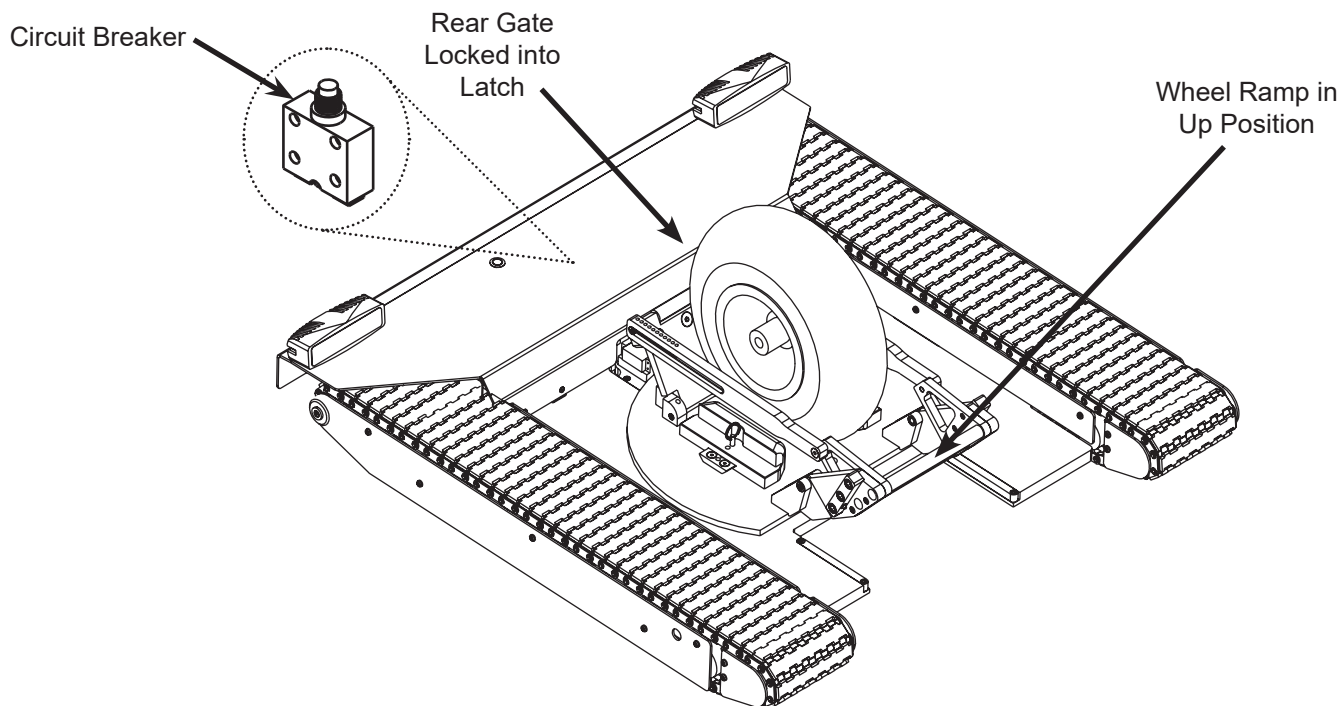

5. The Lazy Susan Lock switch on the radio can be moved to the unlocked position during operation to allow **360° of rotation**.
6. The circuit breaker reset buttons will trip if the tug is overloaded. To reset the circuit breakers open the access cover and locate the two white or black buttons on the circuit board. See image above. Press them down to reset the circuit breakers.

Critical Note:

If the circuit breaker buttons pop up after being reset, the tug is being overstressed and could cause damage to the circuit board. Address any mechanical issues such as a seized sprocket or missing track retainer clips or any driving conditions such as driving up a steep incline or towing above the tugs capacity that could be causing the tug to overstress. If the issue persists call or e-mail AC Air Technology tech support for further assistance.

2. Start-Up Guide

2-4 Unloading the Aircraft Wheel

1. Toggle the Lazy Susan Lock Switch in the middle position and rotate the tug under the aircraft tire until the wheel ramp is facing the front of the tug. Push the tug so the rear gate is slightly pushing against the tire.

Note: It is recommended to chock the wheels to keep the plane from moving

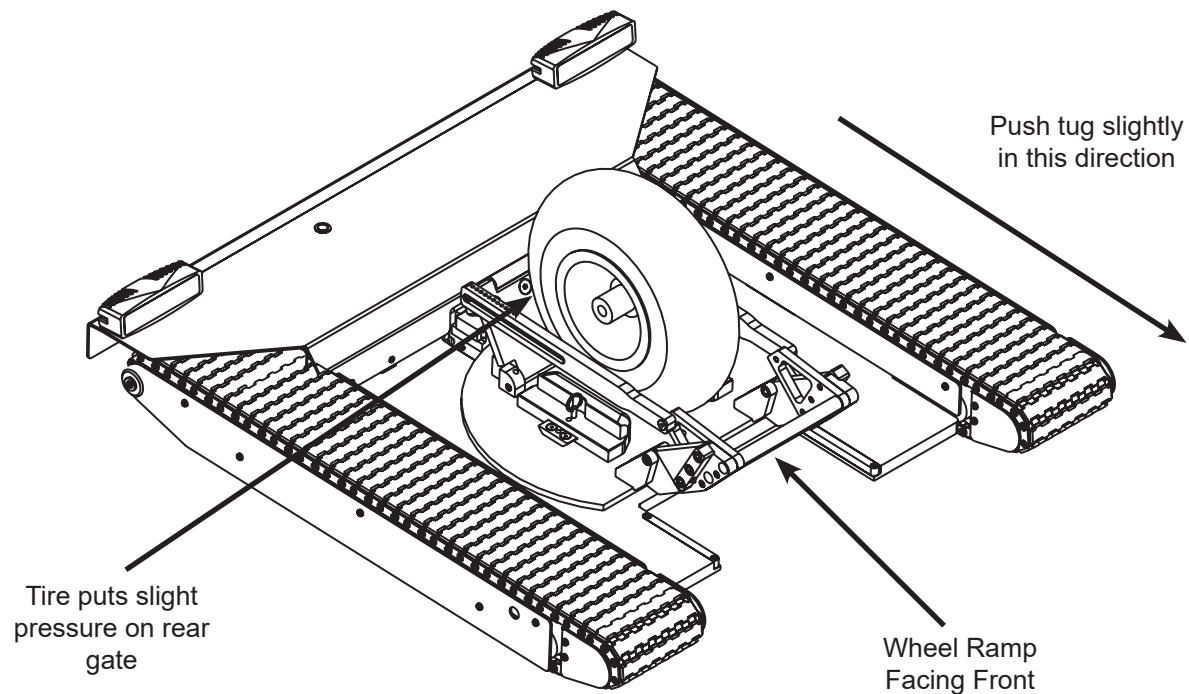

2. Hold the latch release switch on the radio controller and slightly rotate the tug under the tire until the latch releases the rear gate. You will need to visually verify that the latch is released. This may require rotating the tug back and forth slightly until the latch releases.
3. When the latch releases, continue holding the latch release switch on the radio controller and then drive the tug away from the tire. The wheel ramp should pivot to the down position as you move the tug

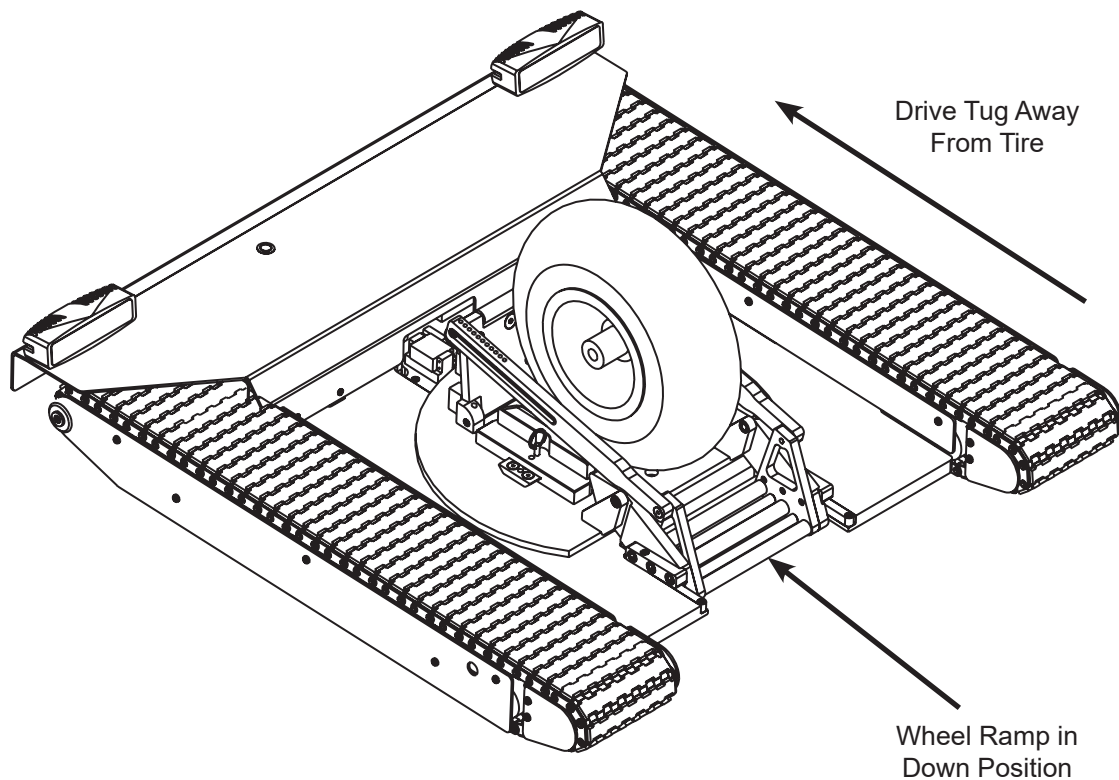

- 4. Continue driving the tug away from the tire until the tire is completely off of the tug. You can stop holding the latch release switch after the tire is off of the tug.

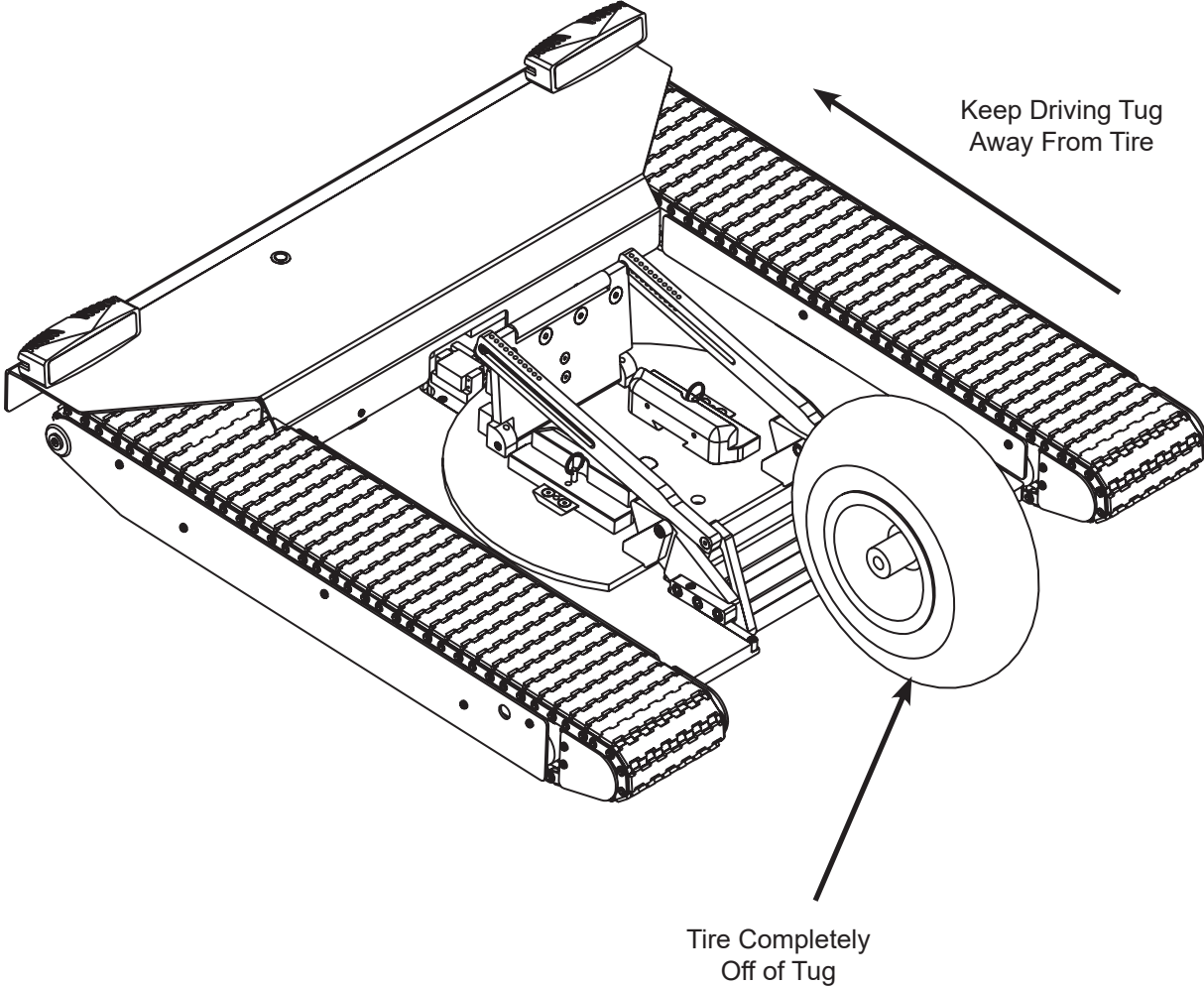

2. Start-Up Guide

2-5 Adjusting the Wheel Cradle

1. Make sure that the wheel cradle is down. If needed, use the radio to unlatch the cradle.

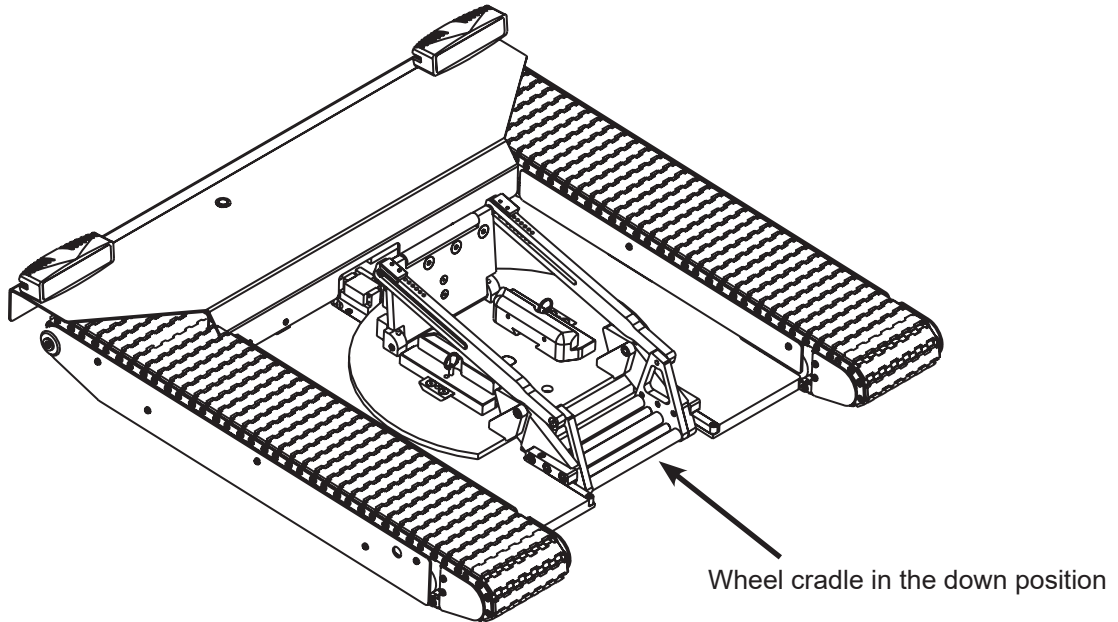

2. Place wheel chocks behind the rear tires of the plane to ensure the plane does not roll backwards.
3. Drive the tug under the wheel of the plane until the wheel cradle locks in the upright position.

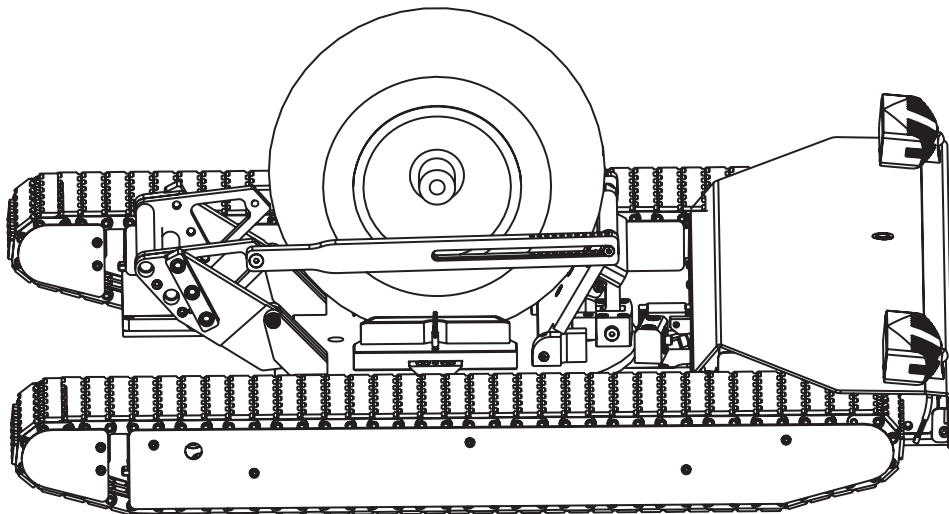

4. Make sure the wheel is touching the back gate.

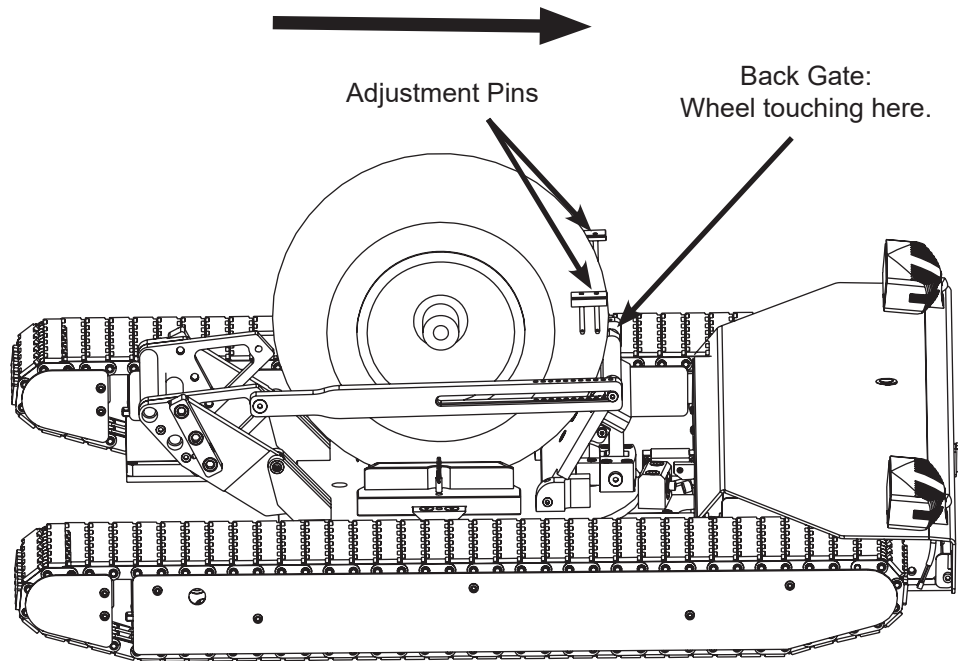

5. Remove the adjustment pins and push the front side of cradle until it is touching the tire and reinstall the pins. The adjustment pins have two legs that need to be inserted to capture the pivot screw between them. You do not want the tire to be too tight in the cradle. Leave a little space for tire size variations.

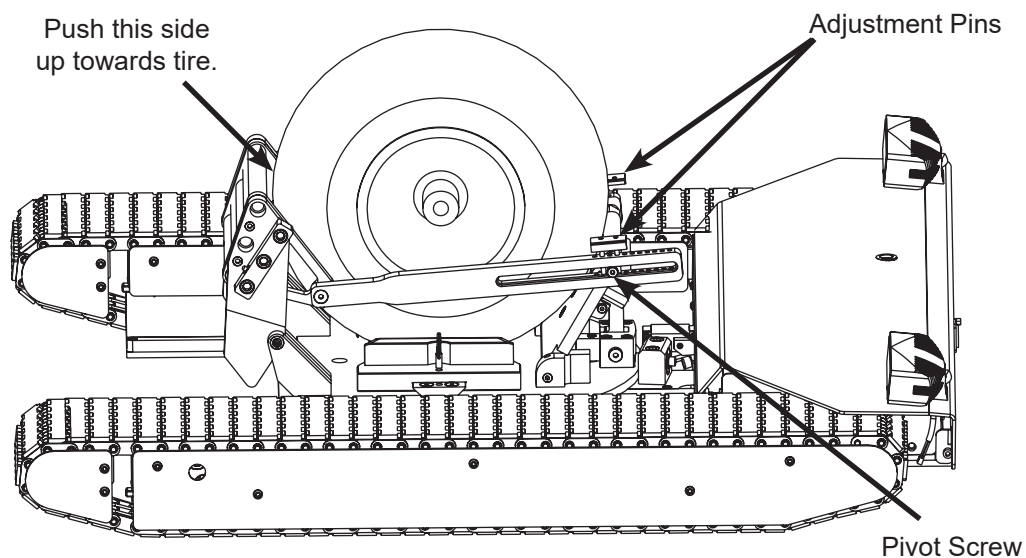

6. Release the latch using the radio and back the tug out from under the plane. Drive the tug back under the tire to check that the wheel cradle is set up correctly and to ensure the cradle is latching securely. When releasing the latch always make sure the wheel is against the back gate. If not, the latch may not release properly.

2. Start-Up Guide

2-6 Adjusting the Tire Guide Spacers

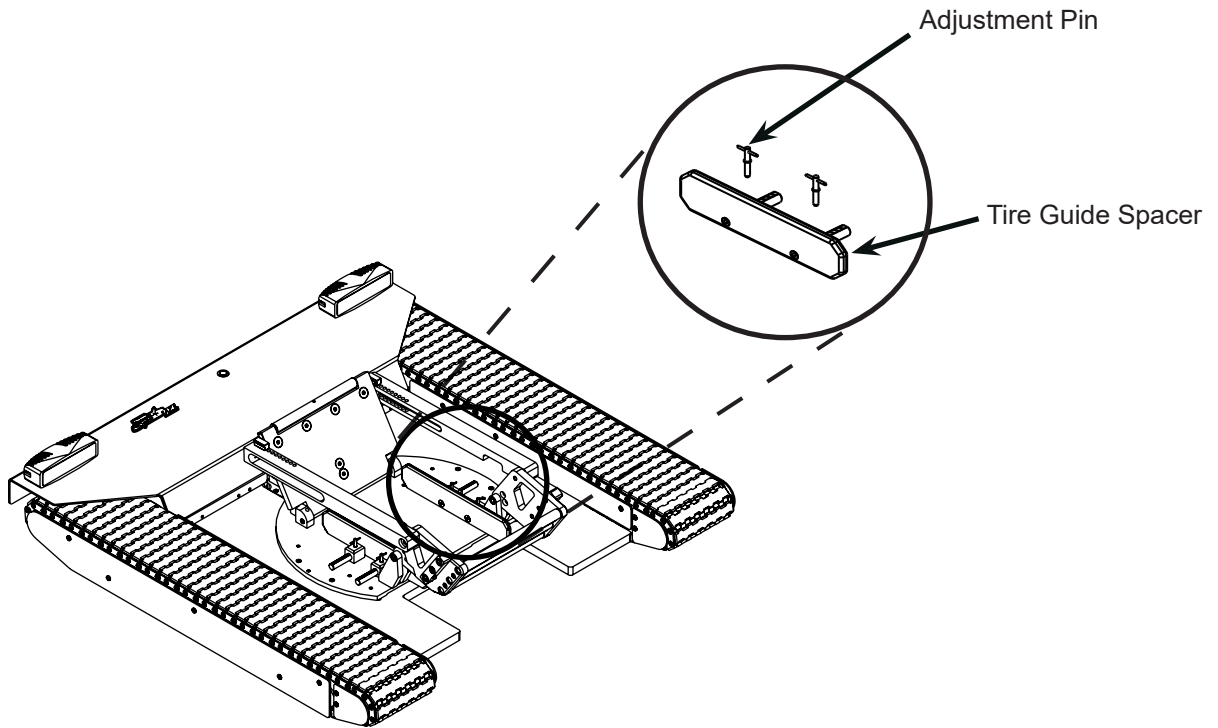

1. If the tire guide spacers are in the widest position and your tire does not fit or it is too close of a fit remove the tire guide spacers and adjustment pins.

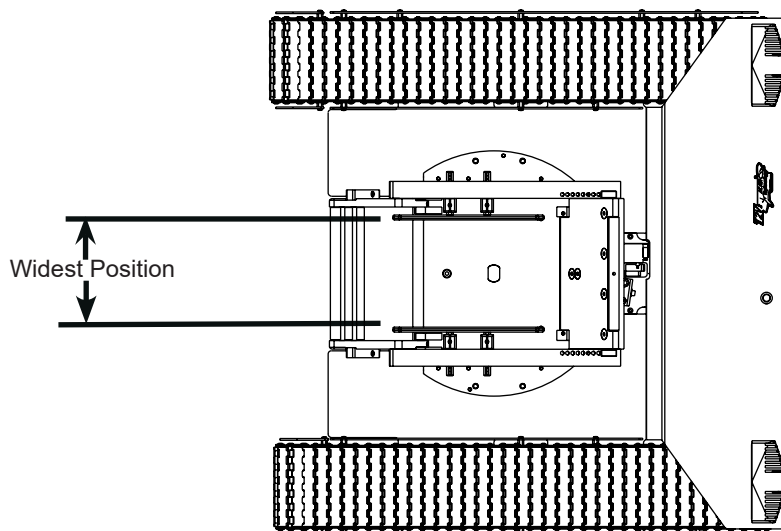

2. Adjust the tire guide spacers by removing the adjustment pins and sliding the spacers towards each other. Ideally the tire guide spacers should be moved the same distance on each side to keep your tire centered in the cradle. The distance between the dovetail spacers should equal the width of your tire plus one inch maximum.

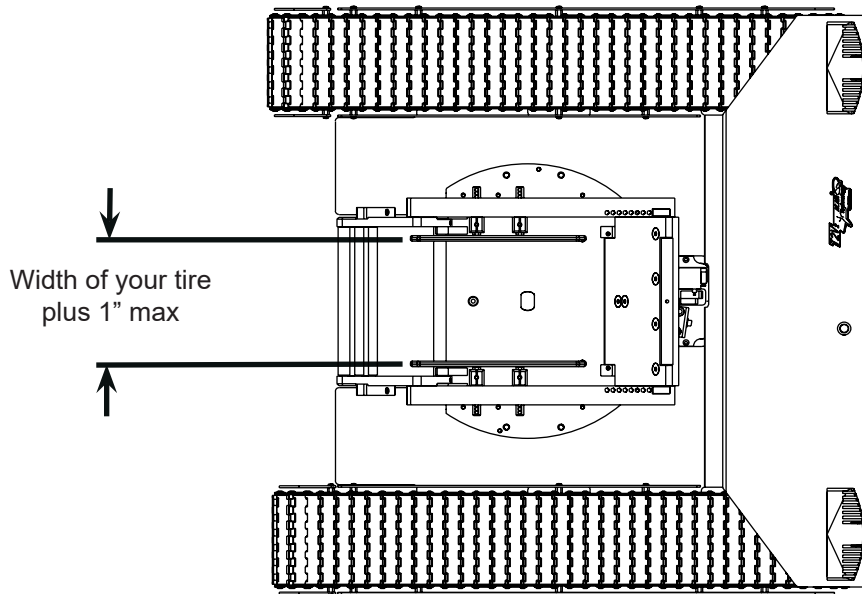

3. Align the adjustment pins to the nearest holes. Insert the adjustment to secure the tire guide spacers.

2. Start-Up Guide

2-7 Adjusting Track Tension

Track tension may need to be adjusted after several hours of use. Follow the instructions below for each track. Ratchet and 12-point socket are provided.

1. Use a 12-point socket and a ratchet to loosen the 12-point front-end retainer bolt. The track cover is hidden from view for clarity.

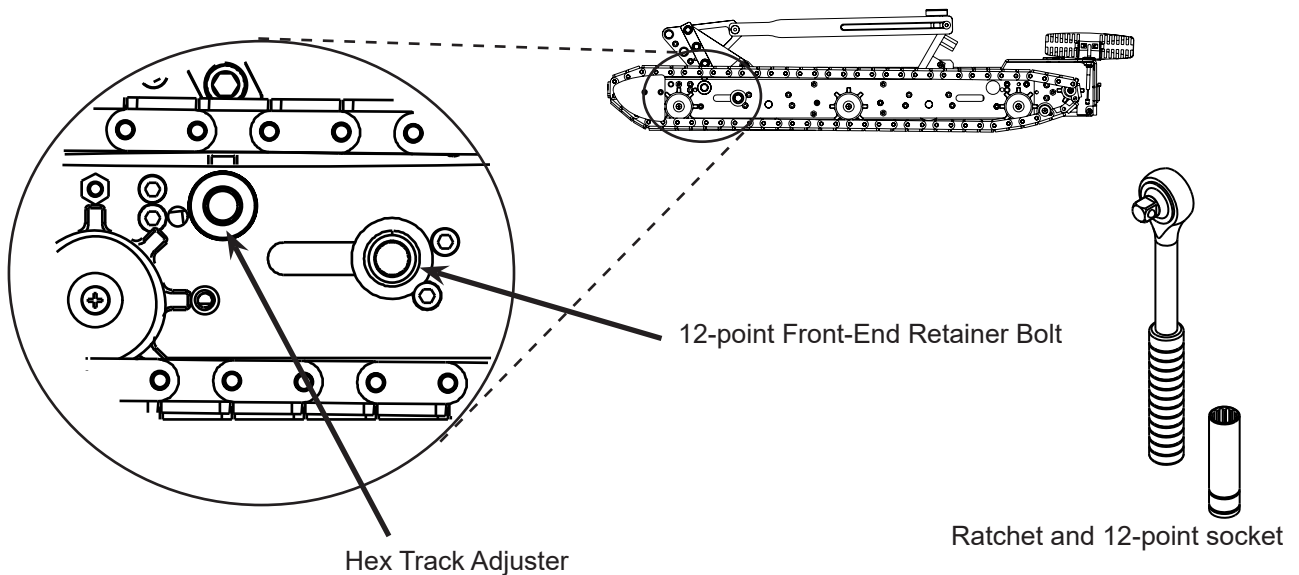

2. Next use a 7/16" hex socket and ratchet to rotate the hex track adjuster.

For the **left side** track rotate the hex track adjuster Clockwise.



For the **right side** track rotate the hex track adjuster Counter Clockwise.



As you rotate the hex track adjuster you will hear and feel a click when it gets to the next tightest setting. When the track is adjusted properly you should have no more than 3/4" of play at the center of the track. **Do not over tighten the tracks.**

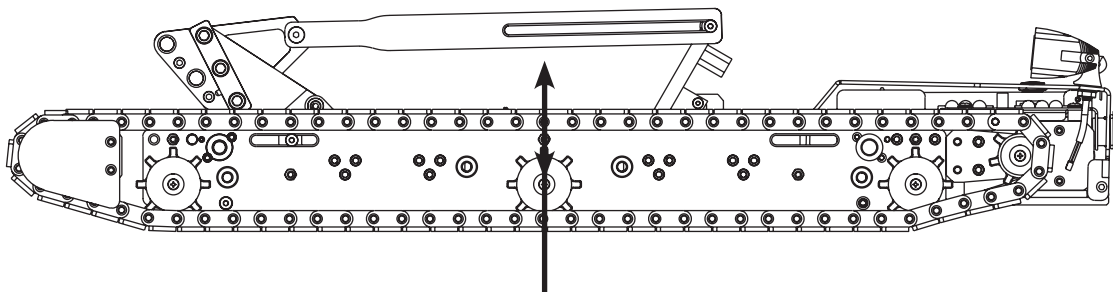

3/4" Up and Down Play at Center of Track

3. Once the track has been adjusted, tighten the 12-point front-end retainer bolt.
4. Re-install the outside track cover.

To loosen the track for removal or repair follow these steps.

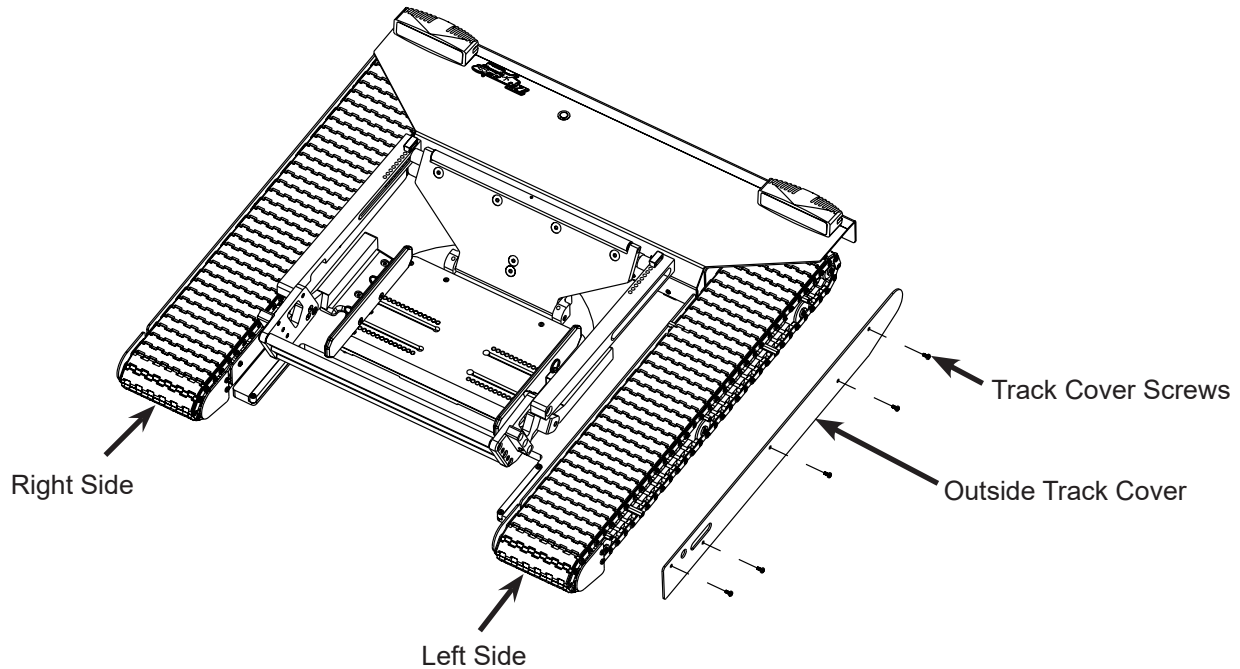

1. Remove the large outside cover from the side you want to loosen.
2. Use a 12-point socket to loosen the 12-point front-end retainer bolt.
3. Next use a 7/16" hex socket to slightly rotate the hex track adjuster to relieve tension on the internal adjuster ratchet mechanism. CW for the left side, CCW for the right side.
4. While relieving the tension insert a 3/16" diameter phillips screw driver into the access hole to release the internal locking mechanism. This should allow the track to become slack. If needed, hold the screw driver in place and push the track inward to allow for more slack. Remove the screw driver once the track is completely retracted.

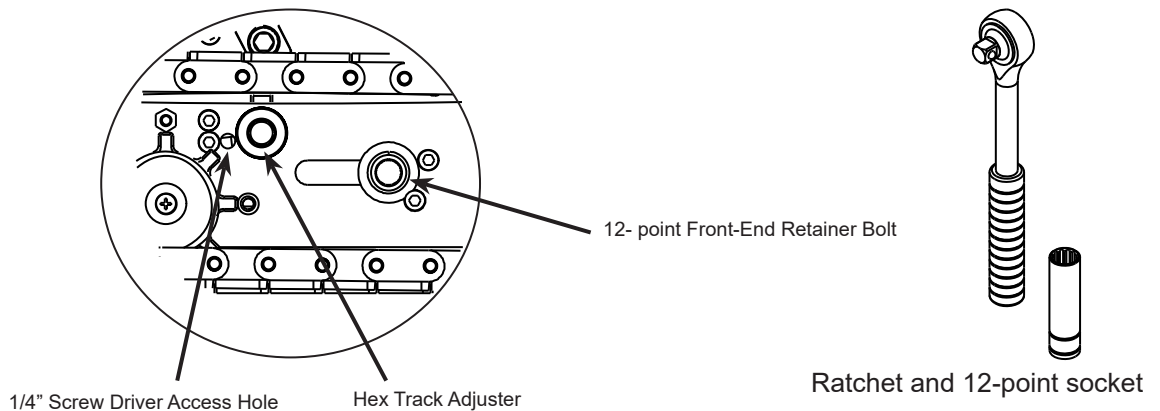

2. Start-Up Guide

2-8 Lifting the Wheel Cradle Ramp

Shims can be used to lift the wheel cradle ramp away from the ground. When traversing over very uneven terrain the wheel cradle ramp may hit the ground and prevent the aircraft from loading onto the tug. Only use the shims when needed.

1. The shims and mounting screws (with attached lock washer) are located in the on-board parts box underneath the electronics cover. The electronics cover is held down magnetically, pull the cover to open.

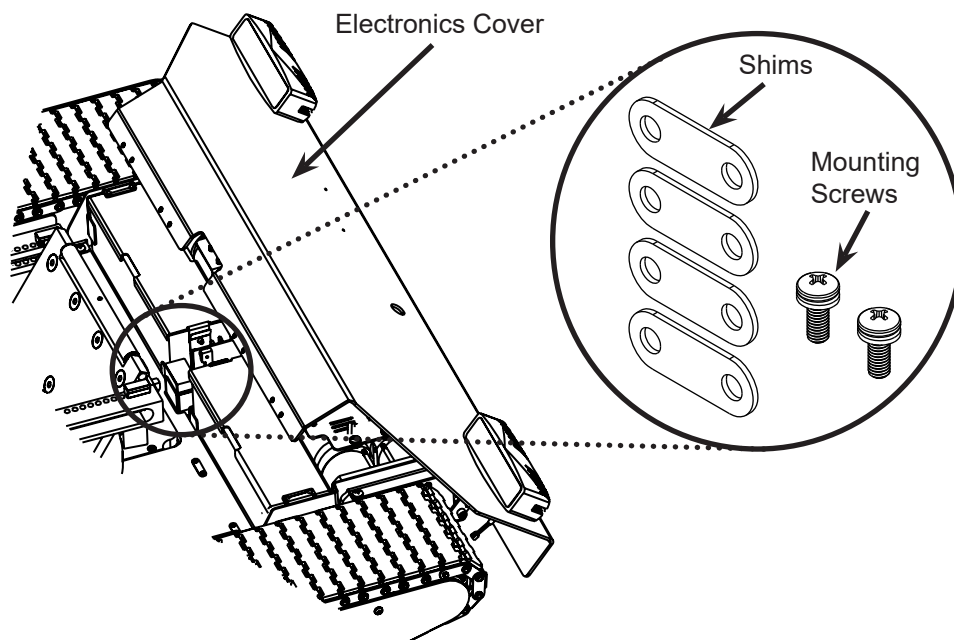

2. With the wheel cradle in the "Up" latched position, install the shims onto the tug mainplate threaded holes located near the loading end. Two shims and one mounting screw per side.

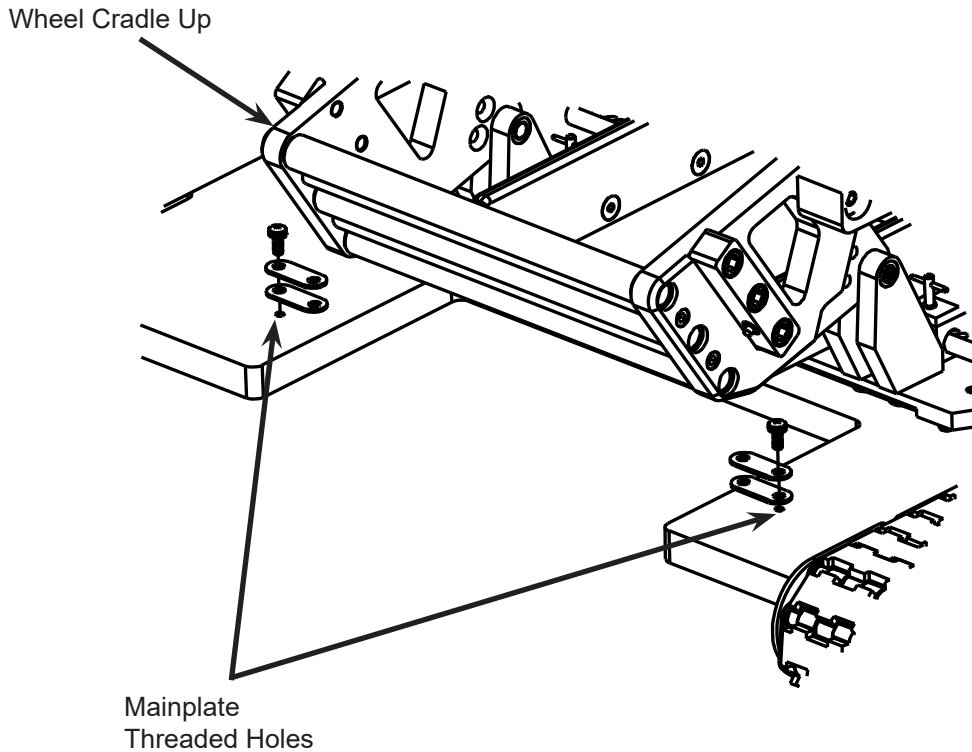

3. Both left and right side shims should be engaged if in the ON position or both sides should be disengaged if in the OFF position to prevent the cradle from twisting.

In the ON position, the wheel cradle should land on the shims lifting the wheel cradle ramp away from the ground.

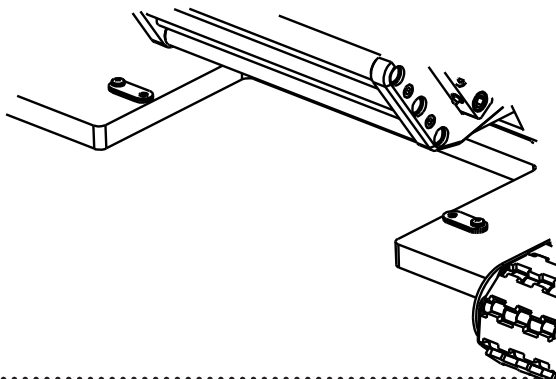

Loosen the mounting screws and rotate 180 degrees to the OFF position when not needed. Tighten screws to secure.

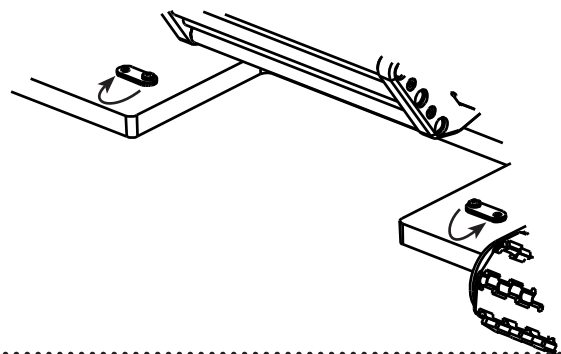

2. Start-Up Guide

2-9 Charging the Tug

1. Before charging your tug, the remote controller and tug should both be turned OFF.

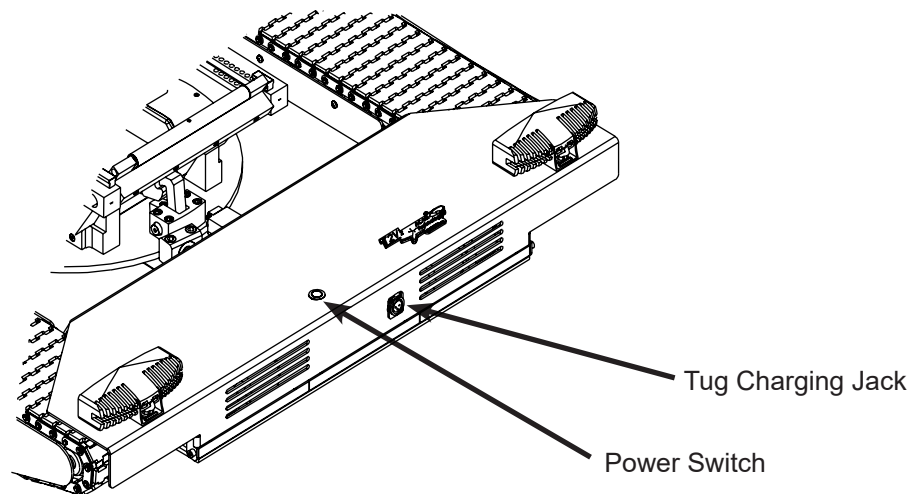

2. Plug charger into charging jack and into a wall socket. The plug can only be inserted in one direction.
3. The charging indicator LED should light up red once the charger is connected properly. The tug will be fully charged once the charger indicator LED turns green.

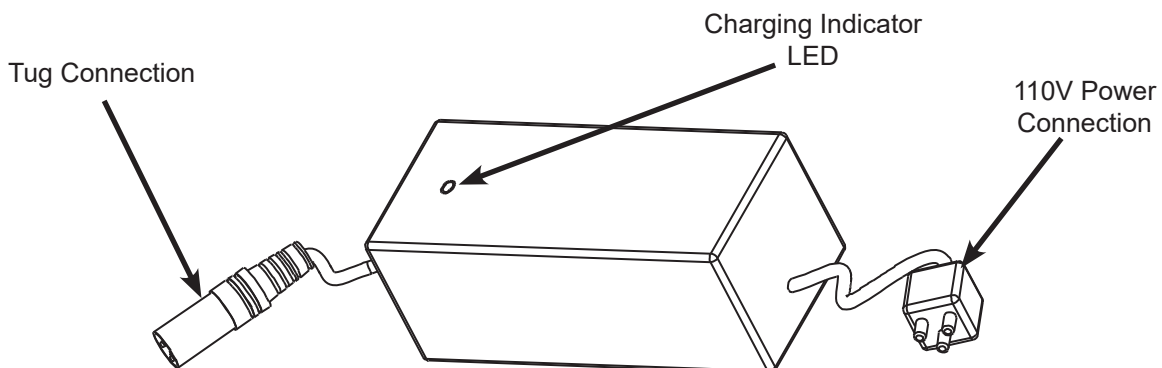

4. Leave the tug charging when it is not in use. The charger is equipped with “smart” charging technology, preventing the battery from overcharging. Keeping the tug on its charger this will prolong the life of the battery.

2. Start-Up Guide

2-10 Charging the Remote Controller

WARNING: Only use the supplied charger to charge the controller when using the supplied batteries or the following:

- 1200mAh to 2200 mAh Ni-MH or Ni-Cd 'AA' Rechargeable Batteries

Using the remote control charger with alkaline batteries installed can damage the controller. Do not use the charger if alkaline batteries are installed in the controller.

1. Plug the transmitter charger into a 110v AC wall socket.
2. Plug the connector from the charger into the charging jack on the transmitter. The charging indicator LED, located on the side of the transmitter, will illuminate green indicating the charger is charging. Once the transmitter is fully charged the charging indicator LED will turn off.
3. The charging rate of the charger is 150mAh. When using the 1200mAh batteries that are supplied, the radio requires an 8 hour charge when fully discharged ($1200/150=8$). If using 2200mAh batteries, it will take approximately 15 hours to charge ($2200/150=14.6$).

It is recommended to leave the remote controller charging when not in use.

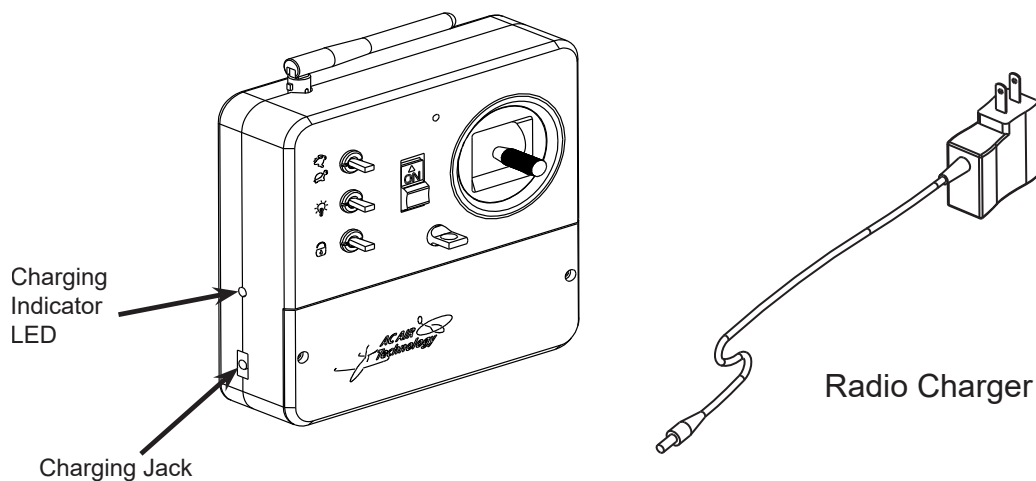

2. Start-Up Guide

2-11 Replacing the Remote Control Batteries

1. Before changing the remote control batteries, the remote controller and tug should be turned OFF.
2. Remove 2 screws on the back cover of the remote controller then remove the back cover.

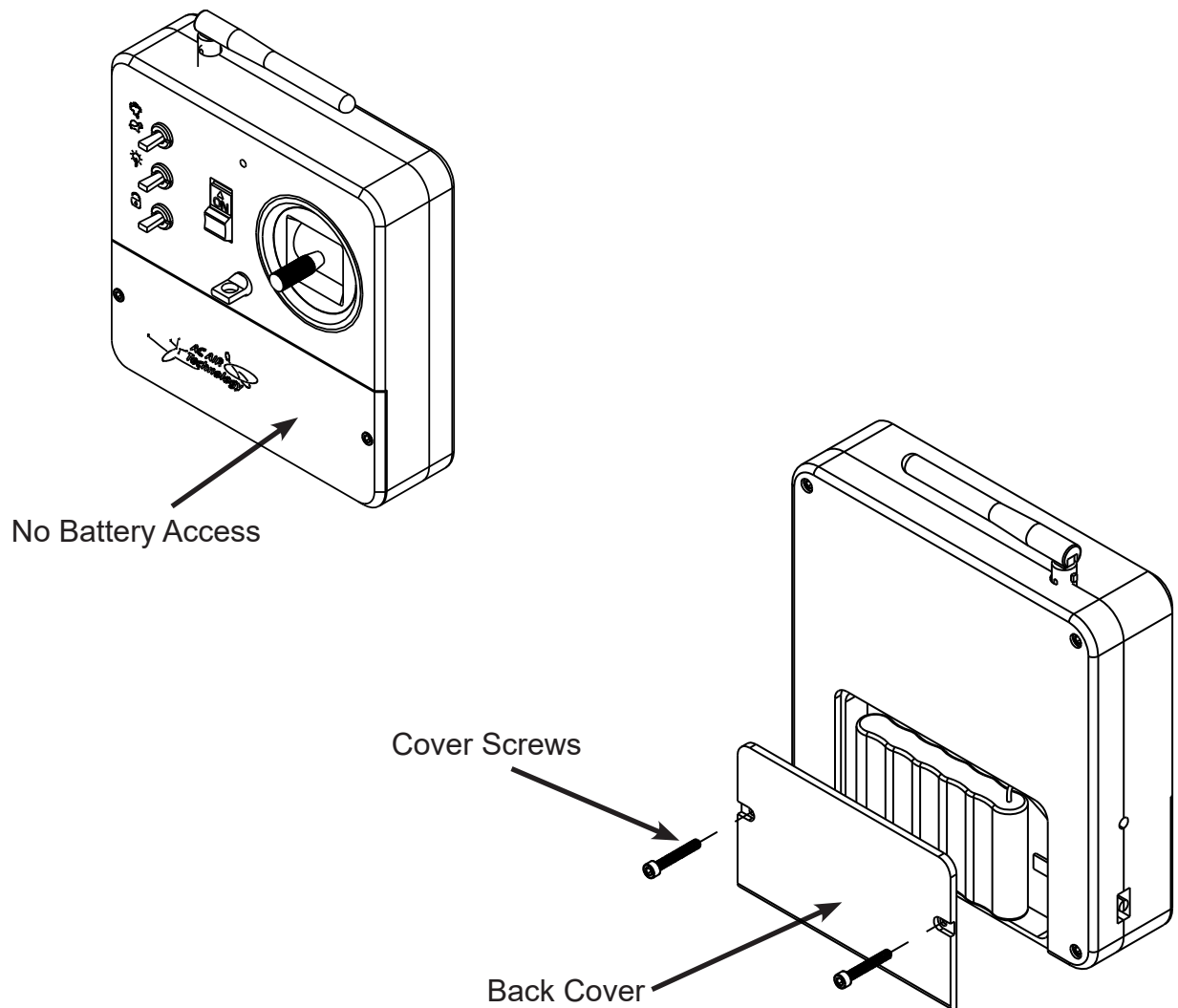

The transmitter batteries are set up like A or B shown below:

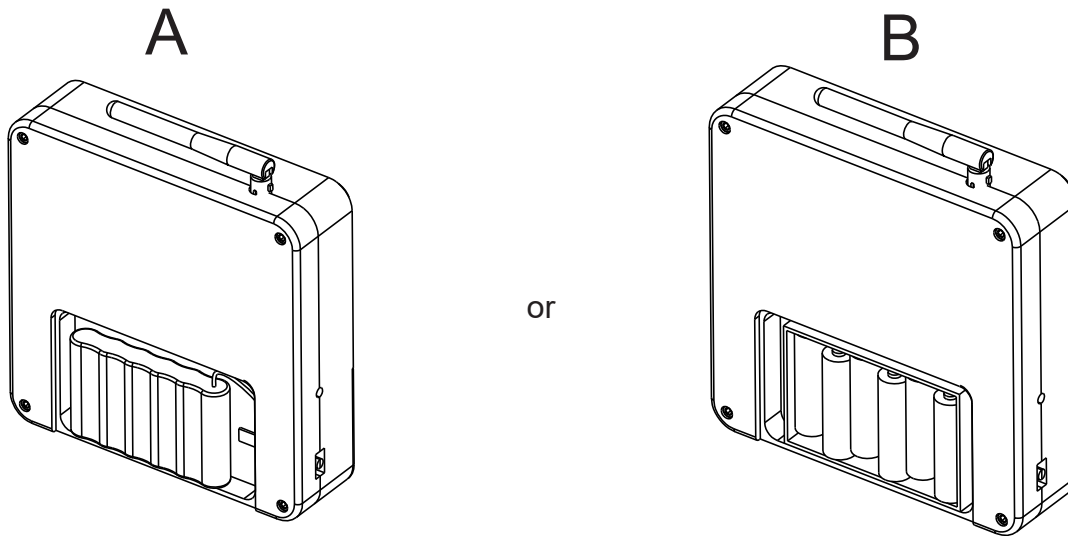

A. A shrink wrapped battery pack

3A. Disconnect the shrink wrapped battery pack and remove the battery.

4A. Replace the batteries by purchasing a new shrink wrapped battery pack from AC Air Technology or installing the supplied battery tray and purchasing 6 rechargeable 'AA' Lithium Ion batteries. Refer to section 2-9 in the owners manual

5A. Reconnect the battery to the transmitter circuit board.

6A. Re-install back cover and screws.

B. A battery tray with 6 rechargeable 'AA' Lithium Ion batteries

3B. Remove the 6 batteries and replace with new rechargeable 'AA' Lithium Ion batteries. Refer to section 2-9 in the owners manual.

Note: A shrink wrapped battery pack can be purchased from AC Air Technology to replace the installed battery tray. To use a shrink wrapped battery pack:

1. Disconnect the battery tray from the transmitter circuit board.
2. Connect the new shrink wrapped battery pack to the circuit board.

4B. Re-install back cover and screws.

Battery Tray

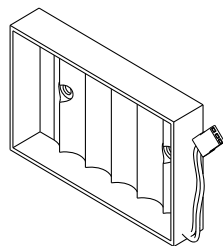

3. Troubleshooting

The troubleshooting guide is divided into three sections: Tug, Remote Controller, Wheel Cradle. Refer to the images and descriptions below as they are mentioned throughout the text.

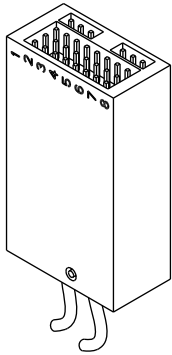

Radio Receiver

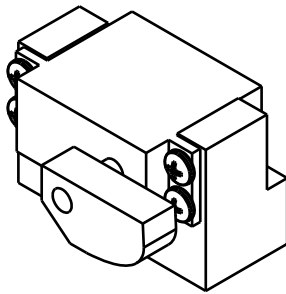

Servo

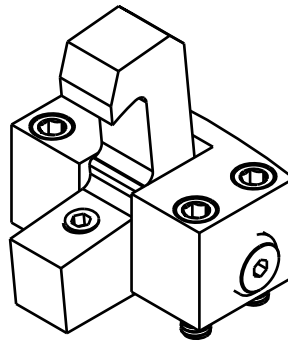

Latch Mechanism

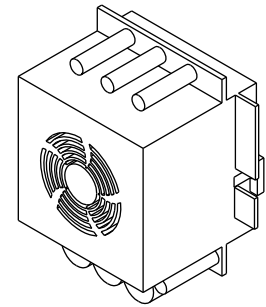

Speed Control

For technical support call or e-mail

AC Air Technology
(855) 884-7222
info@acairtechnology.com

Tug			
Symptom	Cause	Action	Detail
Tug beeps 3 times	Tug is ON	No action required	Tug will beep when initially turned on
	Battery voltage is getting low	Charge tug battery	Tug charger indicator light will illuminate red when charging and green when fully charged. Tug will beep when the battery voltage is below 28 volts (power button flashing red). It is recommended to keep the tug and remote controller charging when not in use .
	Tug is momentarily overloaded	Turn the tug power button OFF then ON again to reset the PC Board.	Steep inclines, turning the tug underneath the wheel without any forward/backward motion, and sudden stops can cause the tug to signal a momentary overload.
Tug beeps continuously	Battery voltage is below operable voltage	Charge tug battery or Replace battery if it does not hold a charge With a voltmeter, check tug charger output voltage for 29.4 volts. Replace charger if it does not output the correct voltage	Tug power button light will blink red. Tug charger indicator light will illuminate red when charging and green when fully charged. It is recommended to keep the tug and remote controller charging when not in use .
Tug indicates a full charge soon after it is plugged into the charger	Charger has failed	Replace tug charger	Tug charger indicator light will illuminate red when charging and green when fully charged
Tug does not turn on	Battery is not plugged into the PC Board	Turn off the remote controller and tug. Open the magnetic tug cover and plug the battery into the PC board. Ensure the connection is fully engaged.	During shipping the battery connection can become loose or disengage from the PC board.
	Battery voltage is below operable voltage	Charge tug battery or Replace battery if it does not hold a charge With a voltmeter, check tug charger output voltage for 29.4 volts. Replace charger if it does not output the correct voltage	Tug charger indicator light will illuminate red when charging and green when fully charged. It is recommended to keep the tug and remote controller charging when not in use .
Tug does not respond to remote controller	Battery is low on remote controller or tug	Charge the battery on remote controller or tug	Tug charger indicator light will illuminate red when charging and green when fully charged. Remote controller charging indicator light, located on the side of the remote, will illuminate green when charging and light will turn off then fully charged. It is recommended to keep the tug and remote controller charging when not in use .
	Tug is overloaded	Reset the circuit breaker(s). Turn off the remote controller and tug.	Steep inclines, towing above the tug's capacity, and sudden stops can cause the tug to activate the circuit breaker.

	Tug is overloaded (continued)	Open the magnetic tug cover and locate the circuit breaker(s) on the PC board. Press the button(s) down to deactivate the circuit breaker (If it is active you will feel some resistance from the button). See the critical note in the "Details" section.	CRITICAL NOTE: If the circuit breaker continues to activate after being reset, the tug is being overstressed and could cause damage to the circuit board. Address any mechanical issues, such as a seized sprocket or missing track retainer clips or any driving conditions, such as driving up a steep incline or towing above the tugs capacity that could cause the tug to overstress. If the issue persists, call or email AC Air Technology tech support for further assistance.
	Remote controller and receiver are not binding	Rebind remote controller and receiver.	Call or email tech support for further assistance
One track turns but the other track does not	Speed controls are not plugged into radio receiver correctly	Turn off the radio controller and tug. Open the magnetic tug cover. Visually inspect the wire from the speed control to the receiver on the PC board for any damage. If there is damage, replace the speed controls. Verify that the wires from the speed controls are connected to slot numbers 1 and 2 on the receiver. Ensure the connections are fully engaged	If there is damage to the speed controls, the PC board may need to be replaced. Call tech support for further assistance.
	Gearbox failure	Open the tug cover and visually inspect the motors for any obstruction. With the radio off, carefully clear any obstruction. With the cover open, radio on, visually check if the motor(s) are turning. If the motor(s) are turning but the track is not, the gearbox needs repair.	Call or email tech support for further assistance
Tug operating sluggish/ low power	Tug is being operated on LOW or MEDIUM Speed.	Switch speed setting on remote controller to HI speed. (Rabbit Icon)	HI speed mode enables the tug's full power. It is recommended to use the tug in HI speed mode when operating outside, in an open area. LOW and MEDIUM speed modes are helpful when operating in small quarters for precise positioning.

Remote Controller			
Symptom	Cause	Action	Detail
Remote controller is beeping	Battery is low	Charge remote controller or replace remote controller batteries	See owner's manual section "Replacing Transmitter Batteries" for details It is recommended to keep the tug and remote controller charging when not in use
Remote controller does not turn ON	Battery voltage is below operable voltage	Charge remote controller or replace remote controller batteries	See owner's manual section "Replacing Transmitter Batteries" for details It is recommended to keep the tug and remote controller charging when not in use
Remote controller indicates a full charge soon after it is plugged into the charger	Charger has failed	Replace remote controller charger	The remote controller LED on the left side of the controller, just above the charging port, will illuminate green to indicate it is charging. The green will turn OFF once it is fully charged.
Remote Controller long-beep sound, tug is ON but the does not respond to remote controller	Joystick connection is loose	Remove remote control back cover which is held on with 4 screws. Disconnect and reconnect the joystick.	Do not forget to reconnect the remote-control battery.
	Joystick needs to be recalibrated	To verify issue, remove remote control front cover which is held on with 2 screws. Turn the remote off then back on <i>without</i> moving the joystick, the screen will read "Throttle Warning"	Call or email tech support for further assistance
Wheel Cradle			
Symptom	Cause	Action	Detail
Unable to release the cradle	Not enough pressure on the wheel cradle back gate	Apply pressure with the tug and remote controller onto the back gate to relieve pressure on the latch mechanism.	If pressure is applied to the loading end of the cradle, away from the latch mechanism, it will cause the latch to bind and not release.
	Servo is not plugged in	Turn off the remote controller and tug. Open the magnetic tug cover. The servo is located next to latch mechanism, follow the wire to the radio receiver, located on the PC Board, and verify it is connected to slot number 6 on the radio receiver. Ensure the connection is fully engaged	
	Servo failure	Visually inspect the servo located next to the latch mechanism. Press the release button on the remote control, if no sound or motion is coming from the servo, the servo needs to be replaced	

	Latch is bound	Visually inspect the latch mechanism. Press the release button on the remote controller. If the cam, located on the servo next to the latch mechanism, turns but the latch does not disengage, service or replace latch assembly.	
--	----------------	---	--

4. Warranty

LIMITED WARRANTY

Your new AC Air Technology Tug is warranted to the original purchaser (only) for one full year from the date of purchase to be free from factory defects in material and workmanship. During this 12-month period, AC Air Technology will repair or replace, at our discretion, the defective component determined by AC Air Technology to be defective.

This warranty does not apply to damage or defect resulting from misuse, improper application, commercial use, or attempted repair by “non-AC Air Technology” service staff. The warranty does not cover shipping or handling cost or any incidental or consequential damage. Batteries and tracks are not covered by warranty.

DAMAGE LIMITS

AC Air Technology shall not be liable for any damage, indirect or consequential, loss of profits or commercial or production loss, or other special loss or damage in any way connected with this product regardless whether such claim is based on warranty, in contract, negligence, or strict liability. In no event shall the liability of AC Air Technology exceed the individual price of the product on which liability is asserted. AC Air Technology has no control of the set up, application, use, modification, or misuse of this product, thus no liability shall be assumed or accepted for any resulting damage or injury. By the first act of use, set up or assembly, the user in using the product accepts all resulting liability. Failure to operate this product in a safe and responsible manner can result in damage or injury, both to the user as well as to others, the product, or property. This product is not a toy and is NOT intended to be used by children without adult supervision. It is essential to read the entire manual and warranty/liability information prior to first use/application/installation of this product to operate correctly and avoid damage/injury,

In cases where the purchaser or user are not prepared to accept liability associated with the use of this product, the user or purchaser is advised to return the unused product immediately in unused condition to the place of purchase.

RETURN PROCEDURE

When sending equipment in for requested warranty service, please include a note describing the problems/concerns with the equipment. You must include your name, address, telephone number and e-mail for prompt service. To request warranty service, a copy of your original sales receipt must be included. Warranty is approved and performed at the discretion of AC Air Technology service department. You are required to pay all postage, shipping and insurance charges.