

# Table of Contents

<b>1. Components .....</b>	<b>3</b>
1-1 Components in the Box .....	3
1-2 Tug Components .....	4
1-3 Spare Parts .....	5
1-4 Track Tools .....	6
1-5 On-Board Parts Box .....	8
<b>2. Start Up Guide .....</b>	<b>9</b>
2-1 Remote Control Operation .....	9
2-2 Operating the Tug.....	11
2-3 Adjusting the Wheel Cradle .....	13
2-4 Adjusting the Tire Guide Spacers .....	17
2-5 Adjusting Track Tension.....	19
2-6 Loading the Aircraft Wheel .....	21
2-7 Unloading the Airplane Wheel .....	22
2-8 Lifting the Wheel Cradle Ramp .....	23
Setup A: Installing Shims Permanently .....	23
Setup B: Installing Shims for Occasional Use .....	25
2-9 Charging the Tug.....	27
2-10 Charging the Remote Controller.....	28
2-11 Replacing the Remote Control Batteries .....	29
<b>3. Stowable Feature .....</b>	<b>31</b>
3-1 Disassemble Tug.....	31
3-2 Reassemble tug .....	35
<b>4. Troubleshooting .....</b>	<b>38</b>
<b>5. Warranty .....</b>	<b>42</b>

# 1. Components

## 1-1 Components in the Box

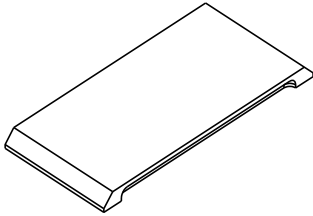

Booster Plate

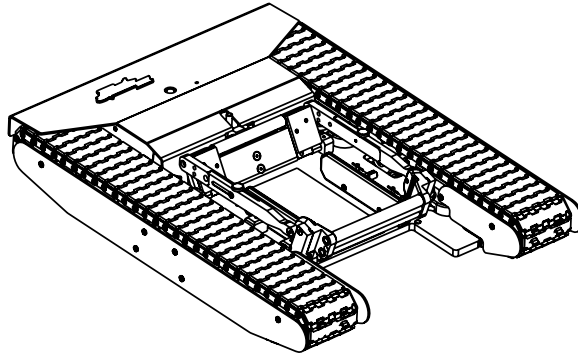

Tug

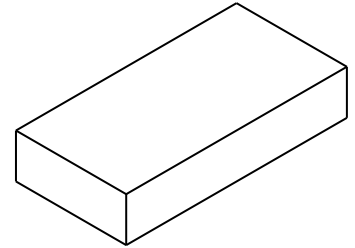

Foam Stand  
(Part of tug shipping foam)

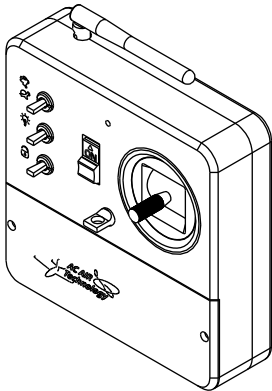

Radio Transmitter

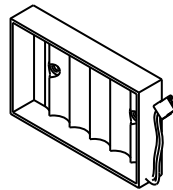

Battery Tray

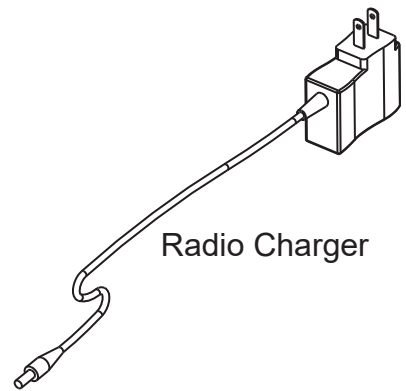

Radio Charger

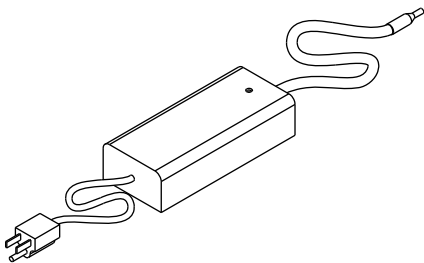

Tug Charger

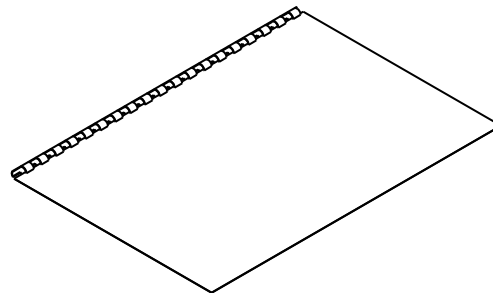

Owners Manual

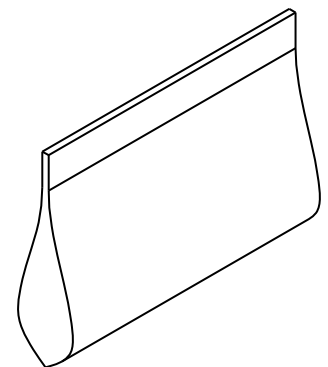

Spare Parts Bag

# 1. Components

## 1-2 Tug Components

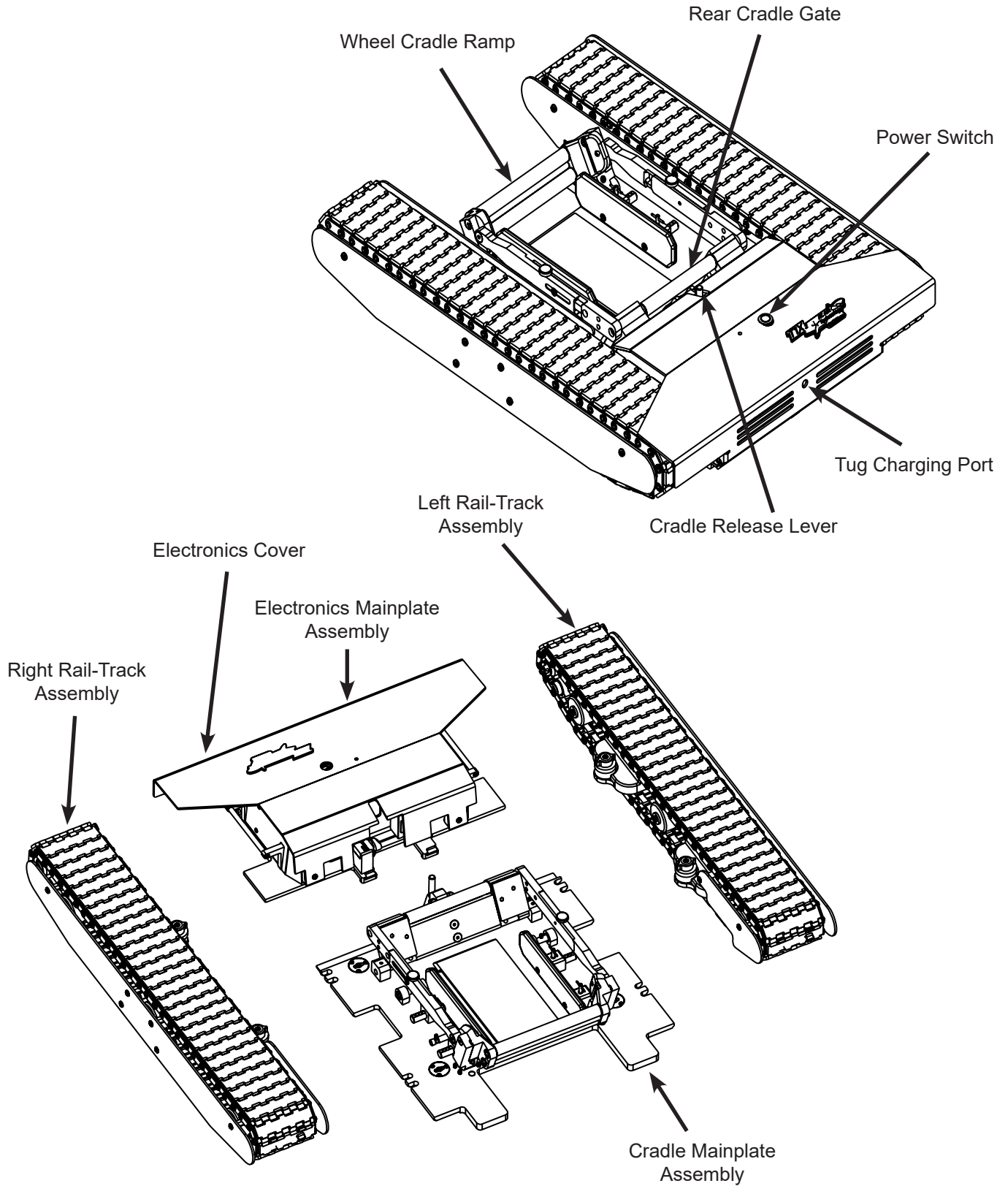

# 1. Components

## 1-3 Spare Parts

### Spare Track Parts

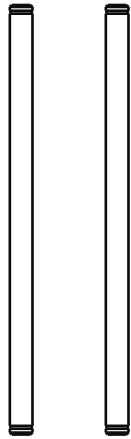

Pins



Retainer Clips

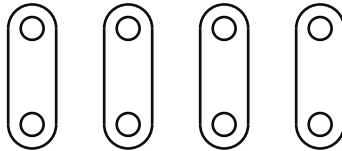

Links

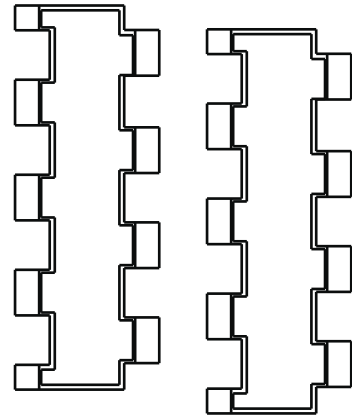

Treads

### Track Install Tools

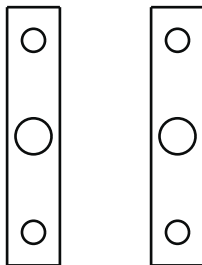

### Fuses

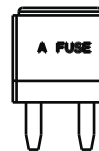

4 Amp Light Fuse



10 Amp Circuit Board Fuse

# 1. Components

## 1-4 Track Tools

The track tools are used to assist in the installation of new tracks.

This section is intended to show how the tools are used only. A detailed instruction guide is provided when purchasing new tracks. Refer to that instruction guide when installing new tracks.

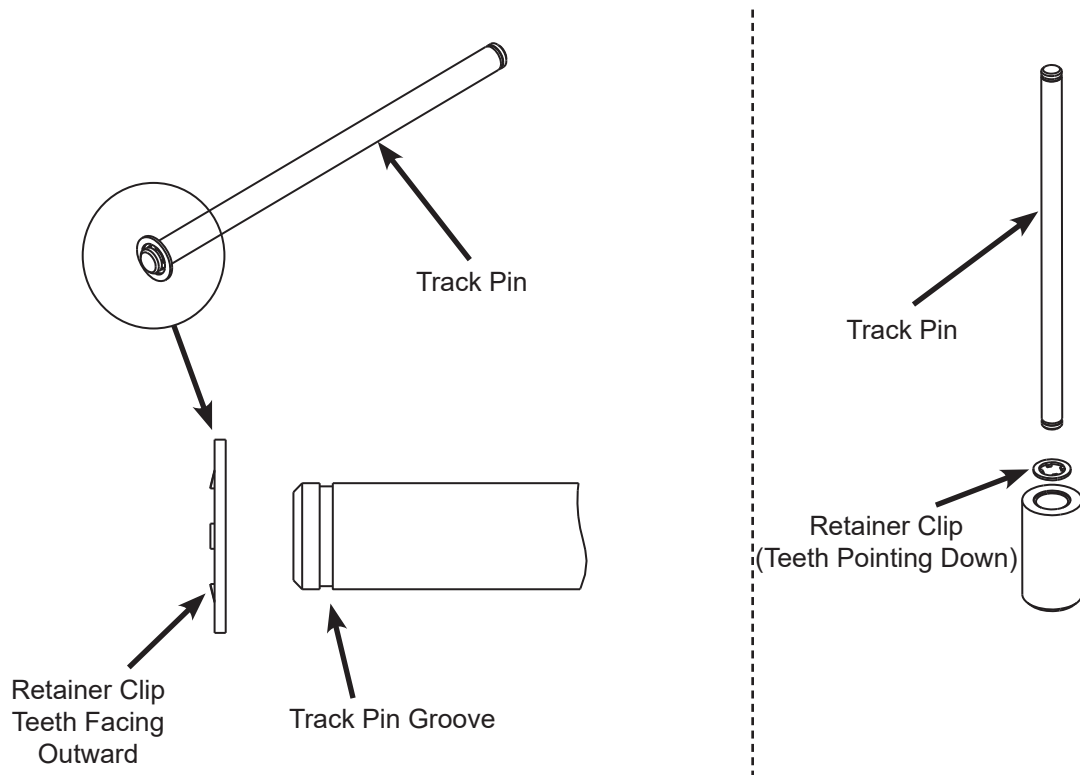

When the retainer clip is properly installed into the track pin groove it should rotate freely inside of the groove.

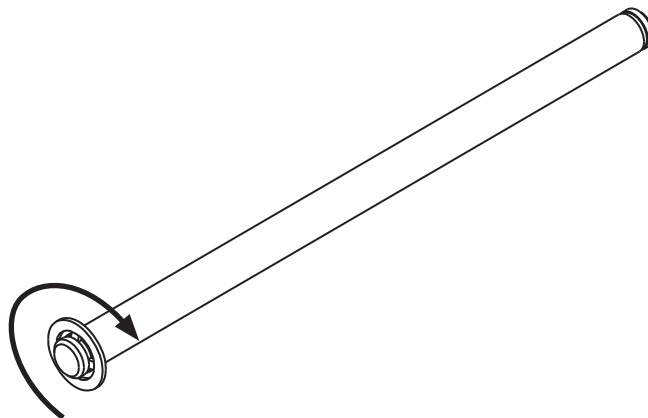

The Track Pin Tools are used to assist in the installation of new tracks when the they are too tight making it difficult to align the pin holes.

Insert the track pin tools on the inside and outside adjacent pins to the missing pin hole. You will need to hold these in place by hand.

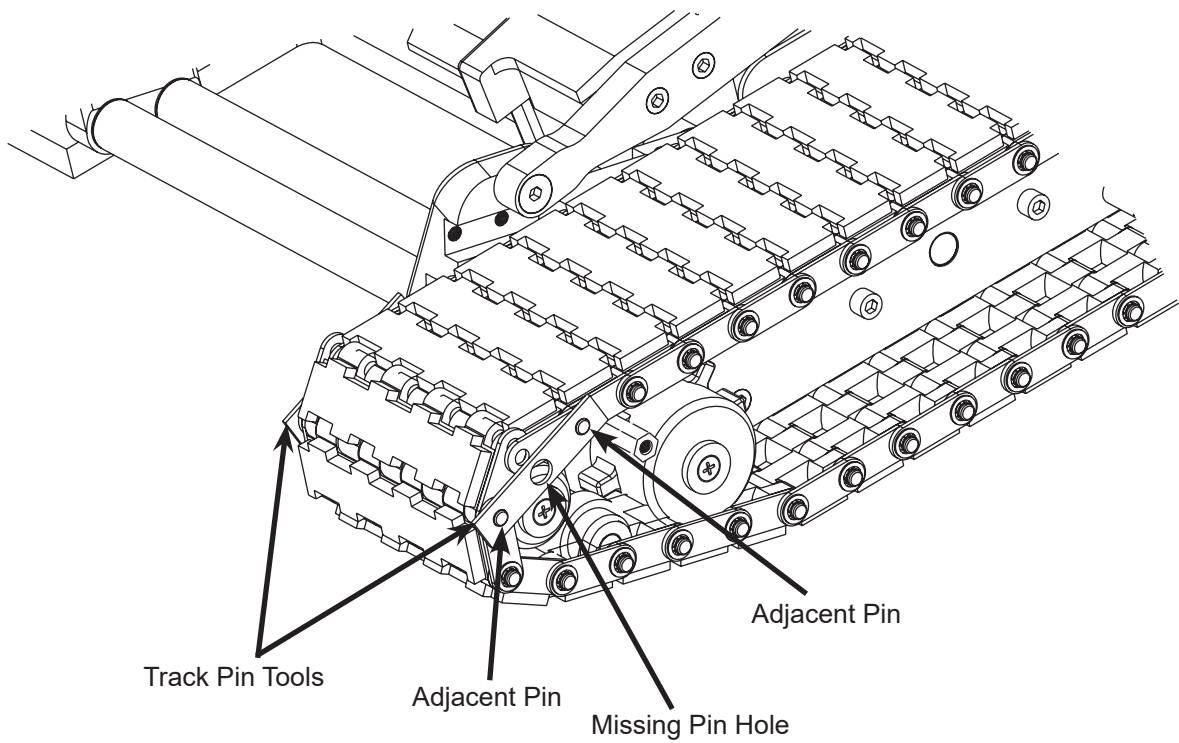

# 1. Components

## 1-5 On-Board Parts Box

The On-Board Parts Box contains spare track links, clips, and tools to quickly replace or repair tracks. It also includes cradle shims and mounting screws to lift the wheel cradle ramp away from the ground. When the ground is very uneven the wheel cradle ramp may hit the ground preventing the aircraft from loading. These components are located on-board the tug, underneath the electronics cover.

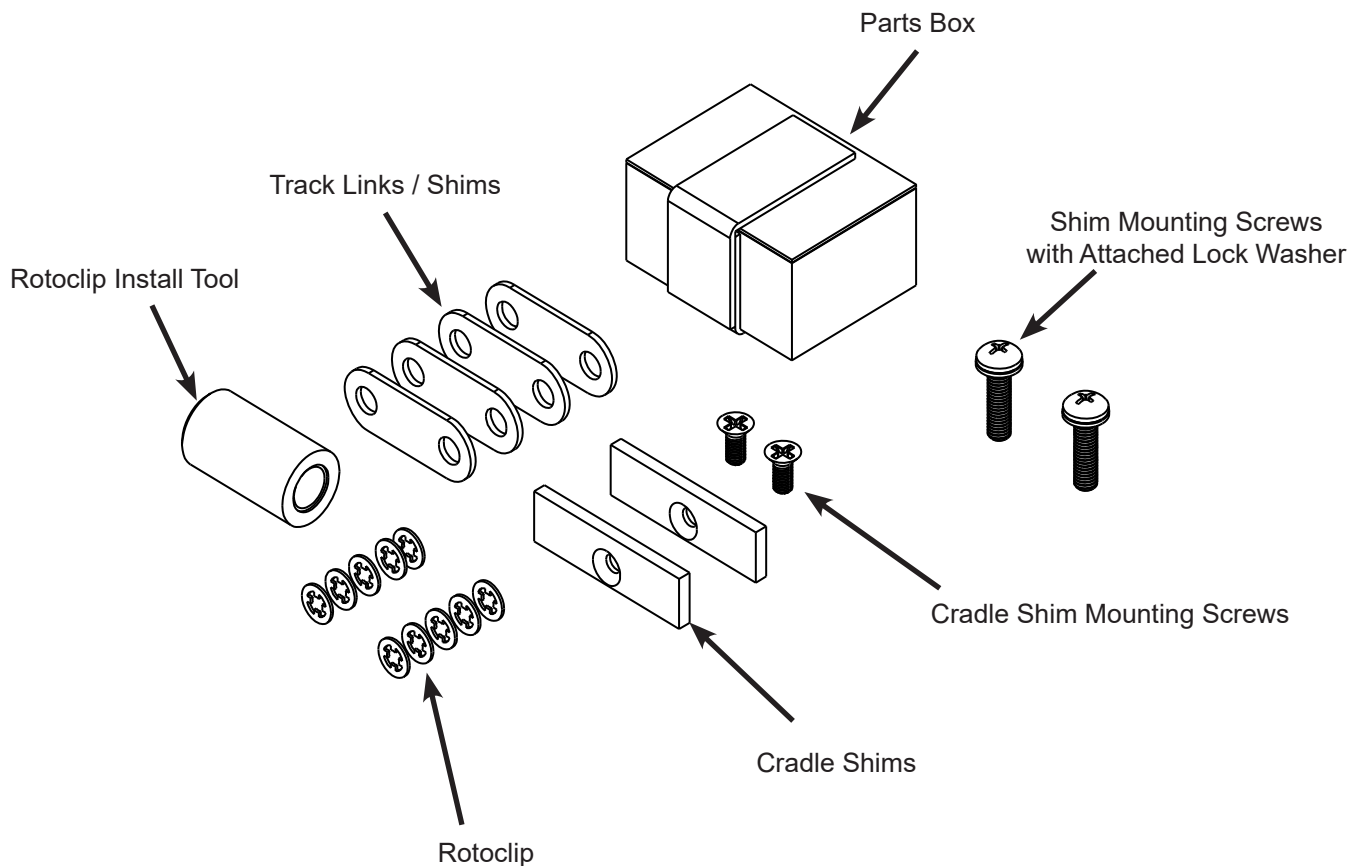



## 2. Start Up Guide

### 2-1 Remote Control Operation

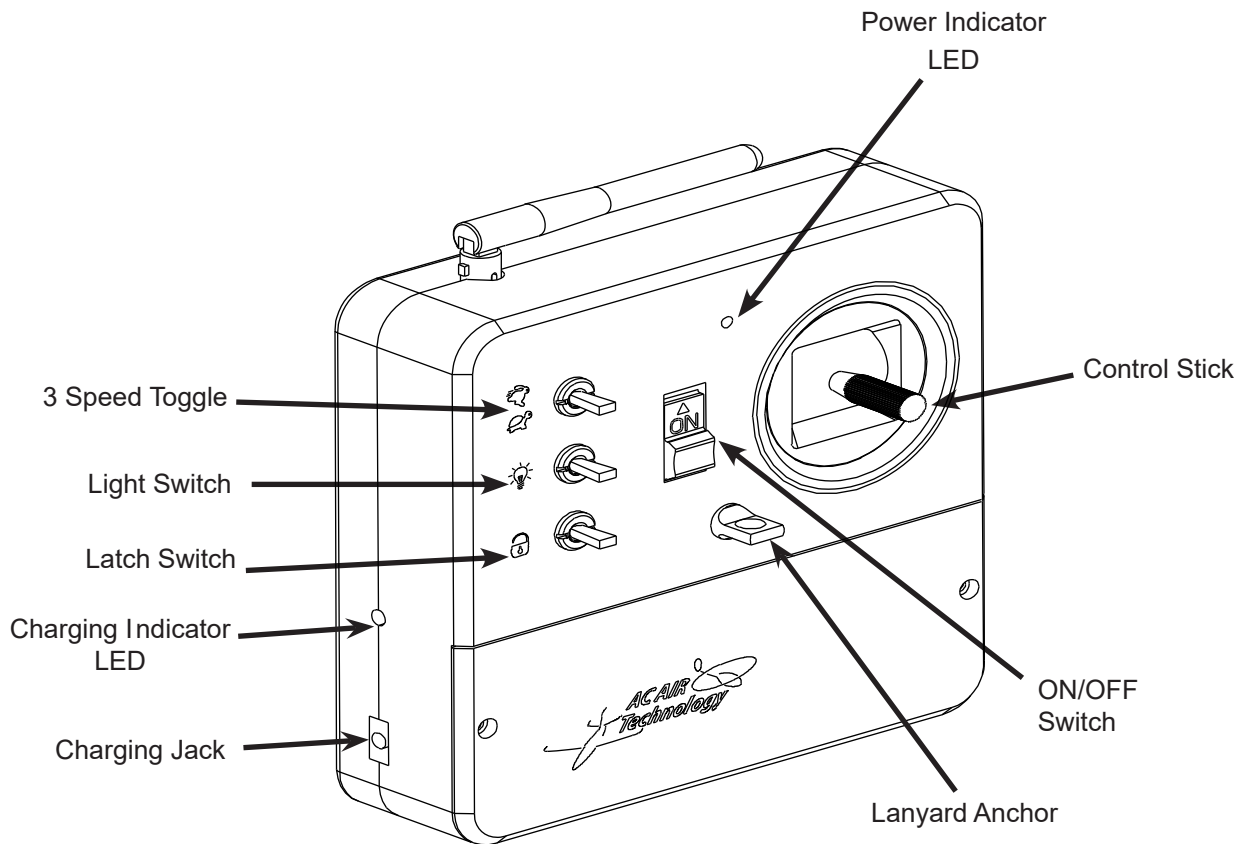

#### Note:

The 3 Speed Toggle ranges from fast, to moderate, to slow. When operating the tug at slow speed it may be necessary to switch to the moderate or fast speed mode on the toggle when turning. Factors such as terrain and incline may affect the maneuverability of the tug. Adjust speed modes at your discretion.

1. Switch the remote control ON. The power indicator light turns on and the remote control beeps once. If this does not happen, check the remote control battery connection for proper installation. When the battery level is low, the remote control will begin to beep repeatedly, signaling to replace or recharge the batteries.

2. To drive the tug, move the control stick in the desired direction.

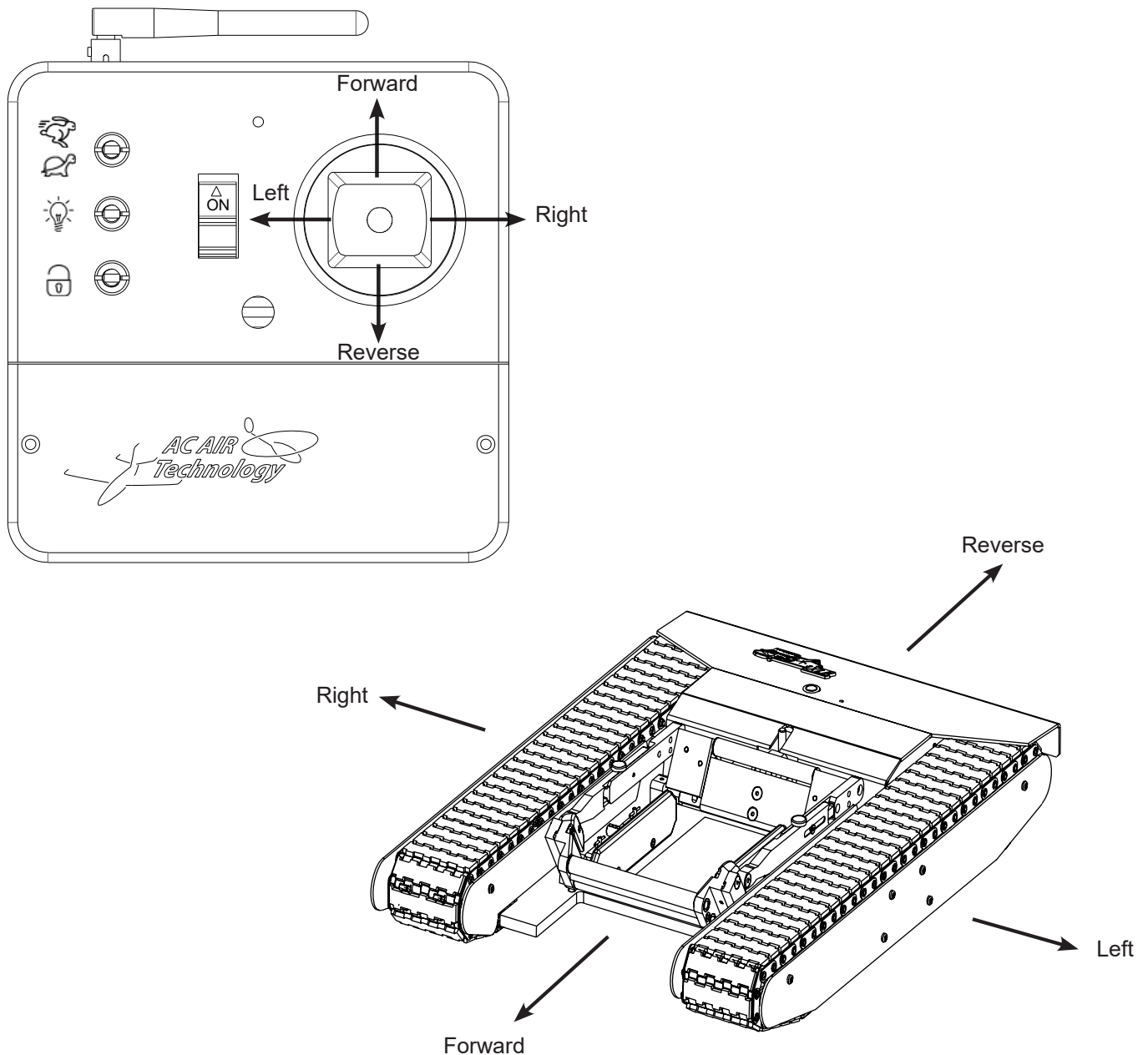

**Warning:** The control stick on the remote controller is very sensitive and will cause the tug to move if it is moved accidentally. Turn OFF the remote controller when not in use.

**Note:** If the remote controller is not used for a few minutes it will start beeping as a indicator that it is still in the ON position. This is not an indicator of a low battery.

## 2. Start Up Guide

### 2-2 Operating the Tug

1. Before turning on the tug, make sure the tracks and bottom of the tug are free from obstruction.
2. Turn the tug on using the ON/OFF switch. There will be a short series of beeps and then the ON/OFF switch will illuminate red to show the tug is on. The ON/OFF switch light will be on solid when the battery is fully charged. When the tug battery is low the ON/OFF switch light will blink and there will also be a beeping sound.

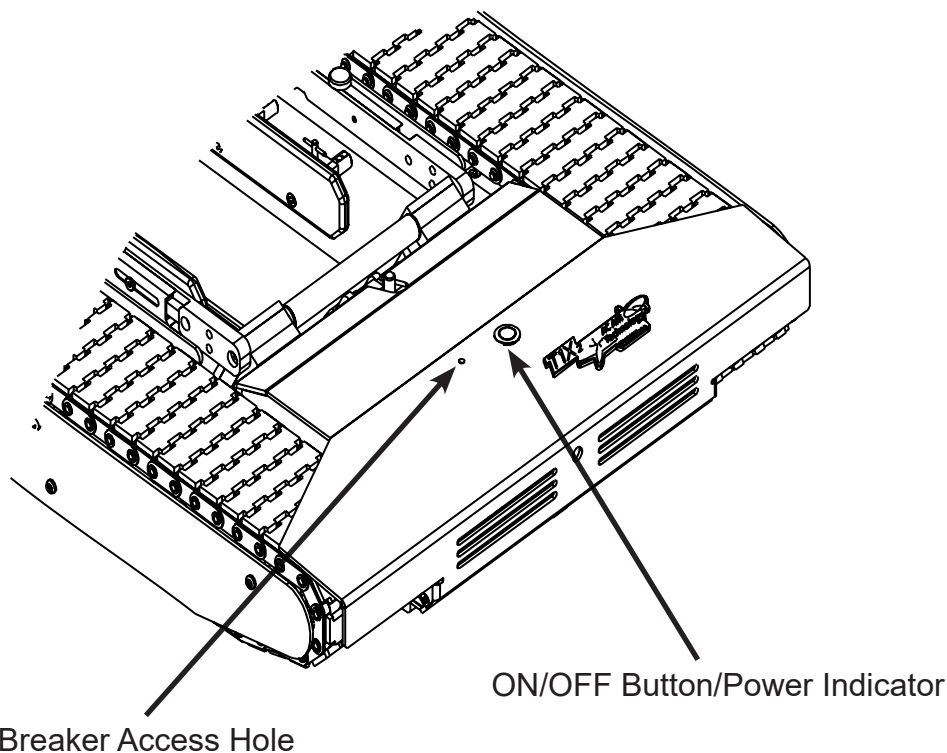

3. Turn on the power switch on the radio controller. The power indicator LED will illuminate green/blue in color. **It is recommended you practice maneuvering the tug prior to loading the plane.**
4. It is recommended to use the radio in fast speed mode. Moderate and Slow speed mode should be used when maneuvering in tight quarters as it reduces the tugs power output.
5. When towing your airplane ALWAYS be cautious of the steering angle limitations of your aircraft. Do not over steer your aircraft with the tug. This can cause damage to your gear.

6. After lifting the tug off of the ground for any reason or taking it in and out of your aircraft, you must check the sprockets for proper seating along the tracks. If the sprocket is not properly seated it could result in damage to the track.

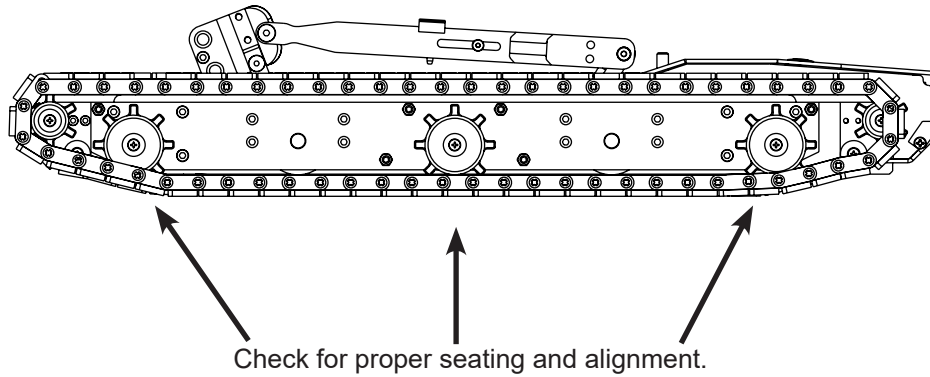

7. Visually check tracks for wear on the treads and wear on the inner plastic surfaces. Also inspect for damaged or missing retainer clips as a result of driving over small rocks. Damaged treads should be replaced before operating the tug.

## 2. Start Up Guide

### 2-3 Adjusting the Wheel Cradle

1. When towing a non-fairing aircraft the front and back cradle gates should be adjusted in the fully extended position. For aircraft with fairings, adjust the cradle gates to the lowest setting. If in the lowest setting and extra clearance is needed, position the **Booster Plate** on the center of the maplate between the tire guide spacers.
2. To adjust the front gate remove the flat head screws from each side and slide the right and left ramp blocks to the desired position. Then reinstall the flat head screws on each side. Note: It may be easier to remove these screws with the link locking pins removed.

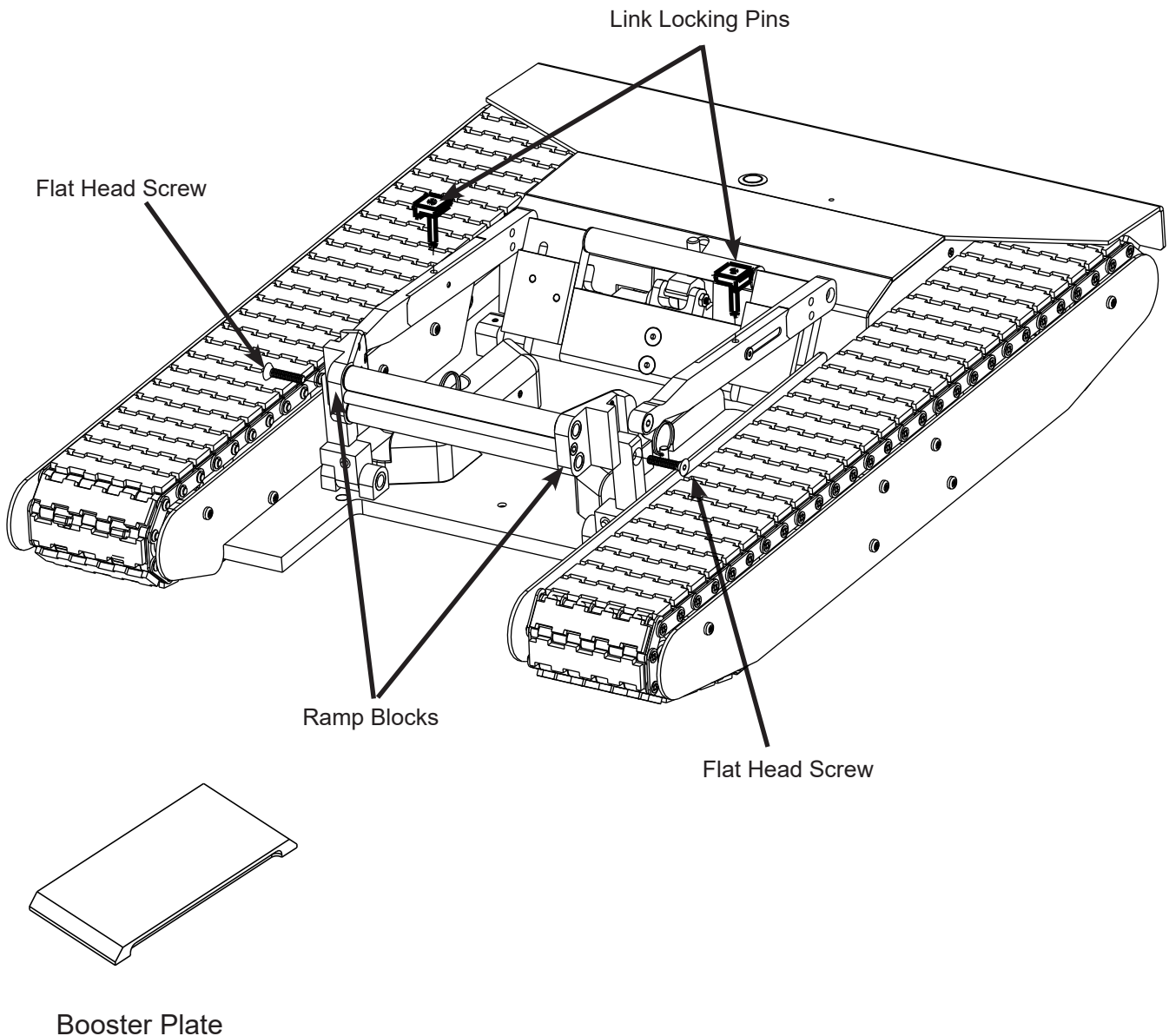

3. Adjust the back gate loosen the 4 flat head screws on the back of the gate. Then slide the right and left sliders to the desired position. Tighten all 4 of the flat head screws-  
Note: It may be easier to remove these screws with the link locking pins removed.

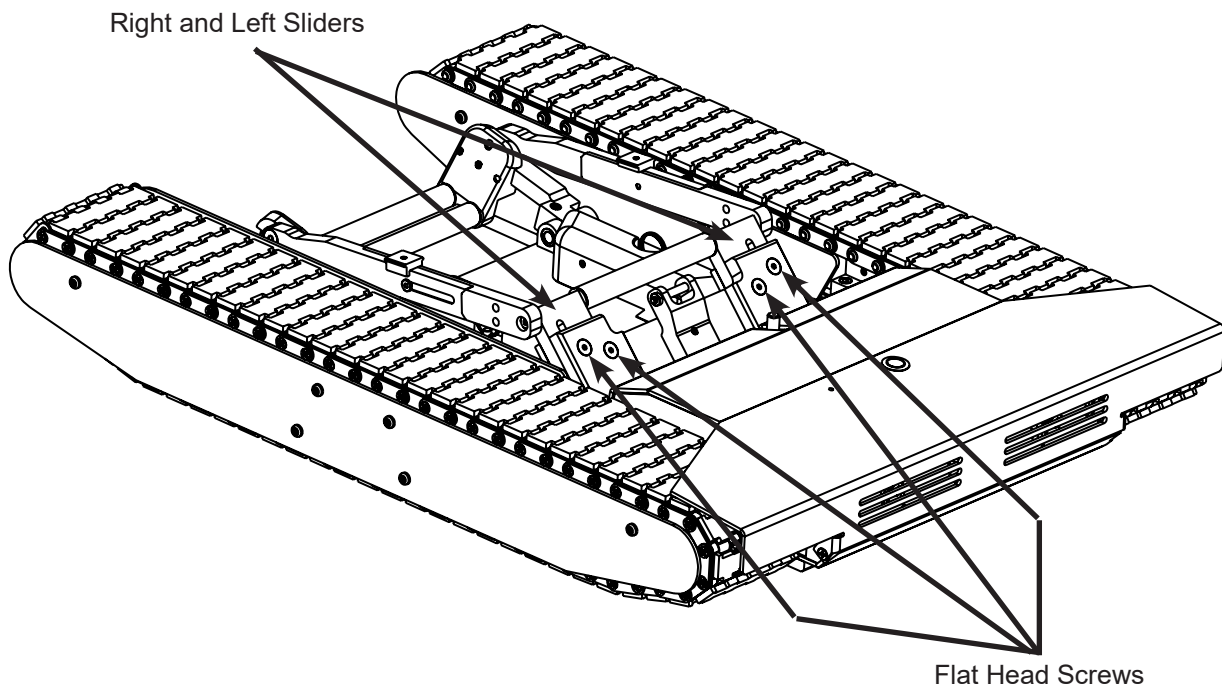

4. Use the cradle release lever to un-latch the cradle and position the wheel cradle in the down position. Adjust the connecting links to the longest length by removing the link locking pins and extending the links. Then re-insert the link locking pins in the link holes.

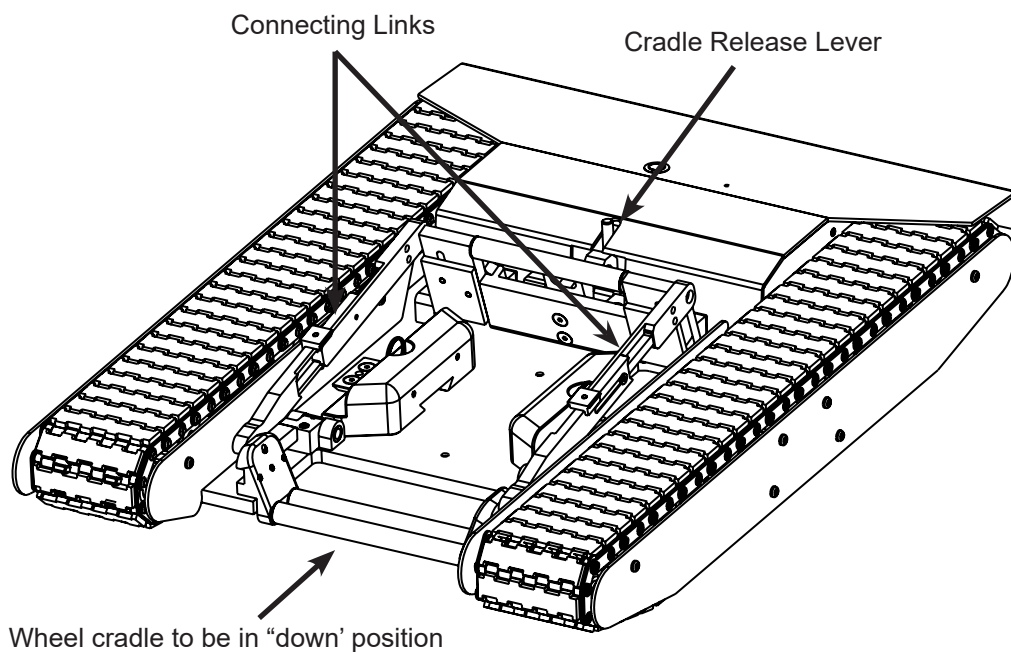

5. Place wheel chocks behind the rear tires of plane to ensure the plane does not ro-back.
6. Drive tug under the wheel of the plane until the wheel cradle locks in the upright position. The wheel should be touching the back gate as shown.

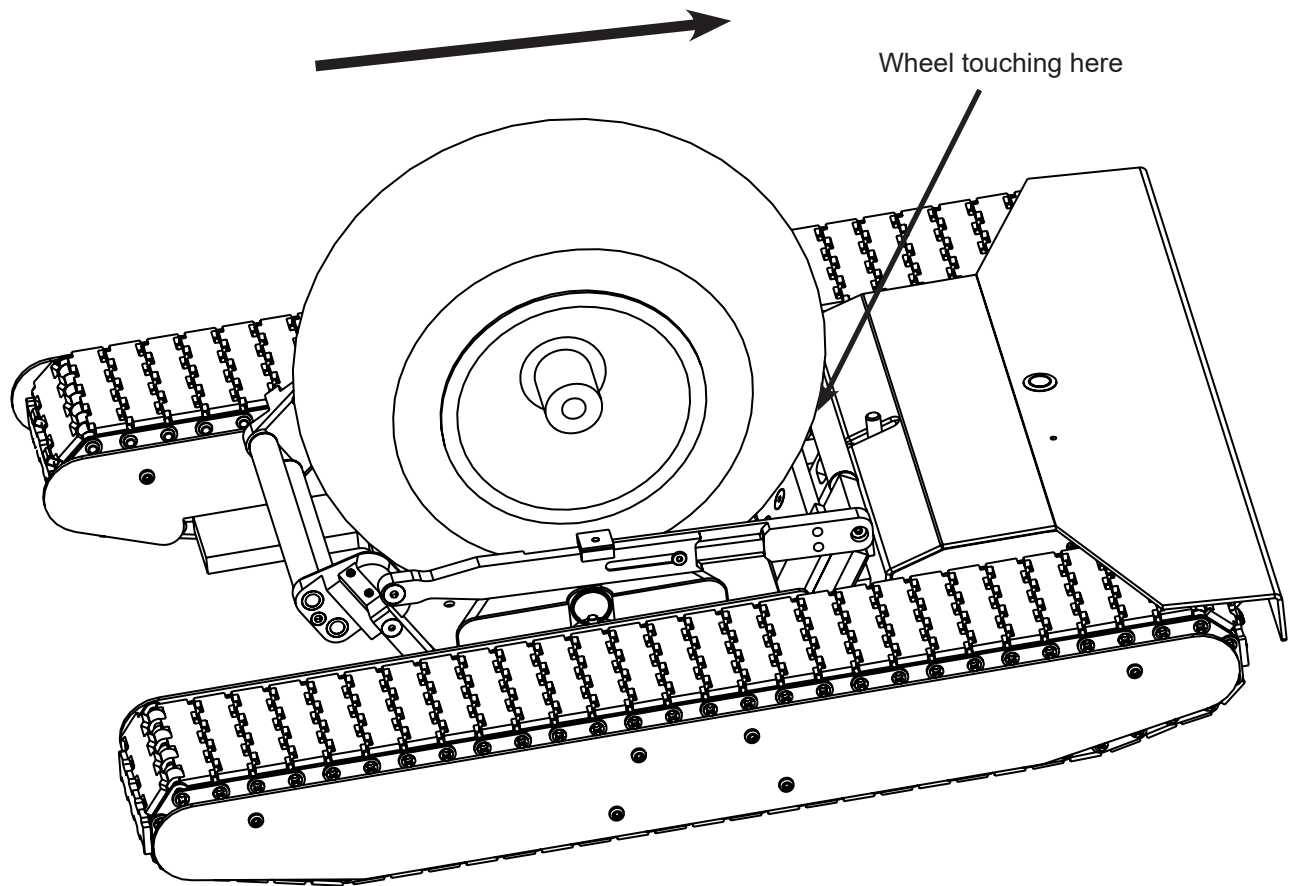

7. Remove the adjustment pins and push the front side of cradle until it is touching the tire and re-install the pins. If the pins cannot be installed while the front side is touching the tire, move the front side of cradle away from the tire until the pin can be inserted into the next closest hole. You do not want this to be too tight on the tire. **Do not force the adjustment pins in.**

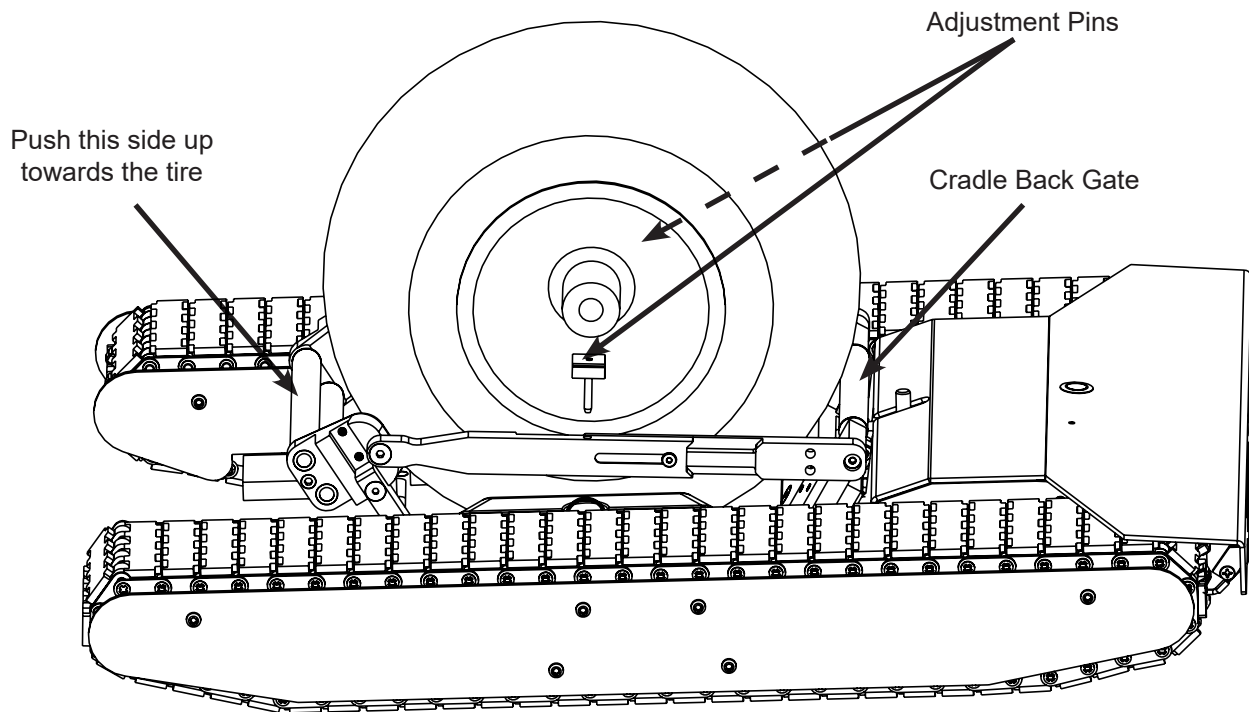

8. Release the latch using the radio and back the tug out from under the plane. Drive the tug back under the tire to check that the wheel cradle is set up correctly and to ensure the cradle is latching securely. When releasing the latch always make sure the wheel is against the back gate. If not, the latch may not release properly.



## 2. Start Up Guide

### 2-4 Adjusting the Tire Guide Spacers

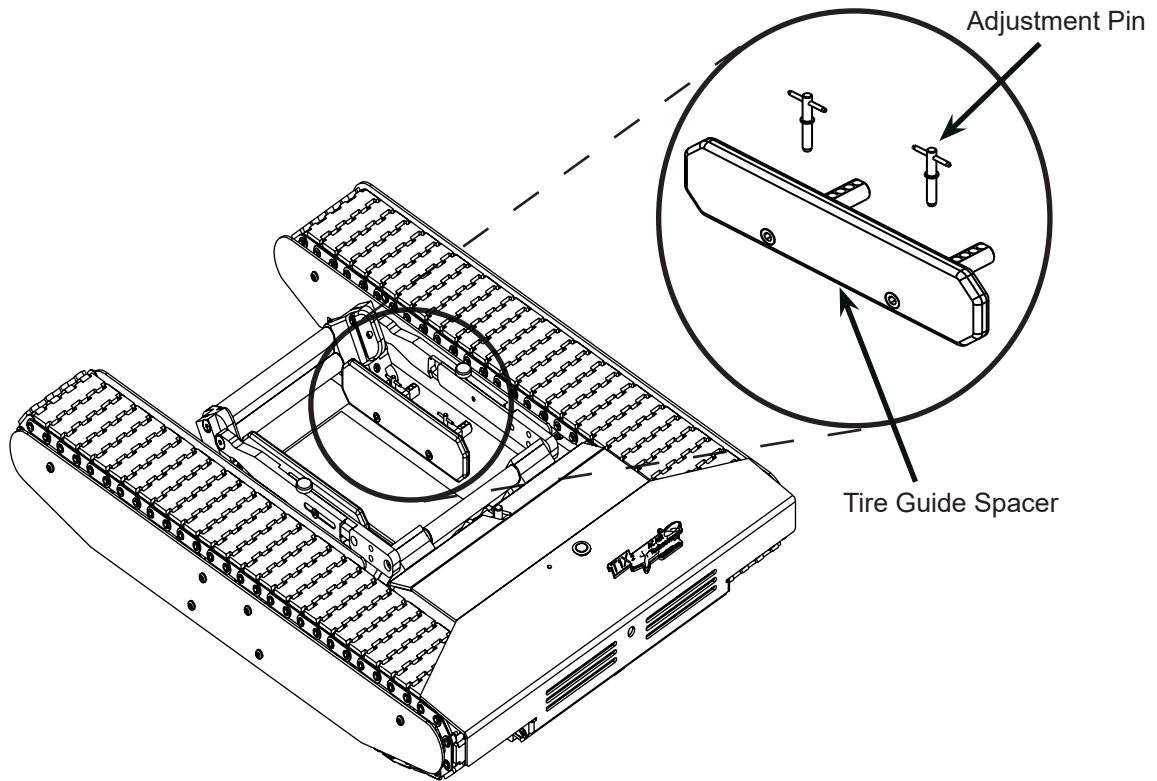

1. If the tire guide spacers are in the widest position and your tire does not fit or it is too close of a fit, remove the tire guide spacers and adjustment pins.

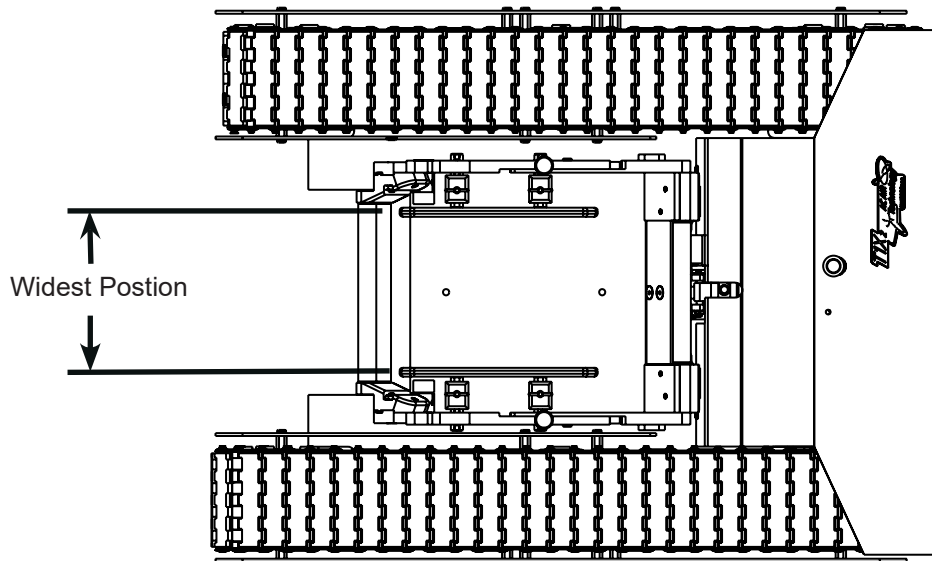

2. Adjust the tire guide spacers by removing the adjustment pin and sliding the spacers towards each other. Ideally the tire guide spacers should move the same distance on each side to keep the tire centered in the cradle. **The distance between the tire guide spacers should equal the width of your tire plus one inch maximum.**

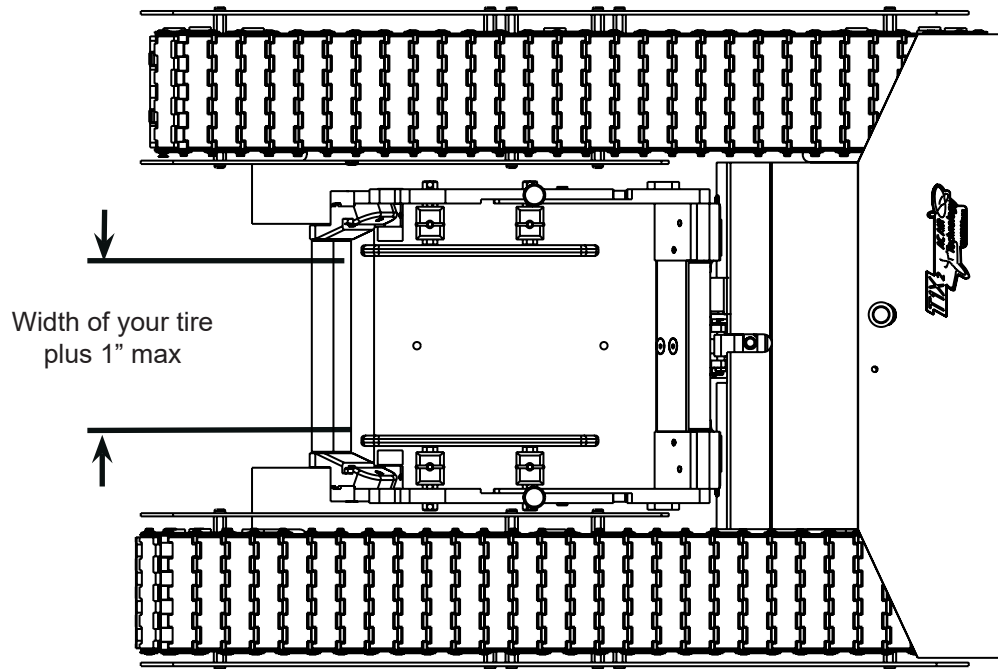

3. Align each tire guide spacer to the nearest hole in the adjustment pin block. Insert the adjustment pin in the nearest hole position to secure in place. Adjusting the spacers correctly will prevent the tire from turning inside the cradle.

## 2. Start Up Guide

### 2-5 Adjusting Track Tension

Track tension may need to be adjusted after several hours of use. Follow the instructions below for each track.

1. Remove 6 track cover screws and remove the outside plastic track cover.

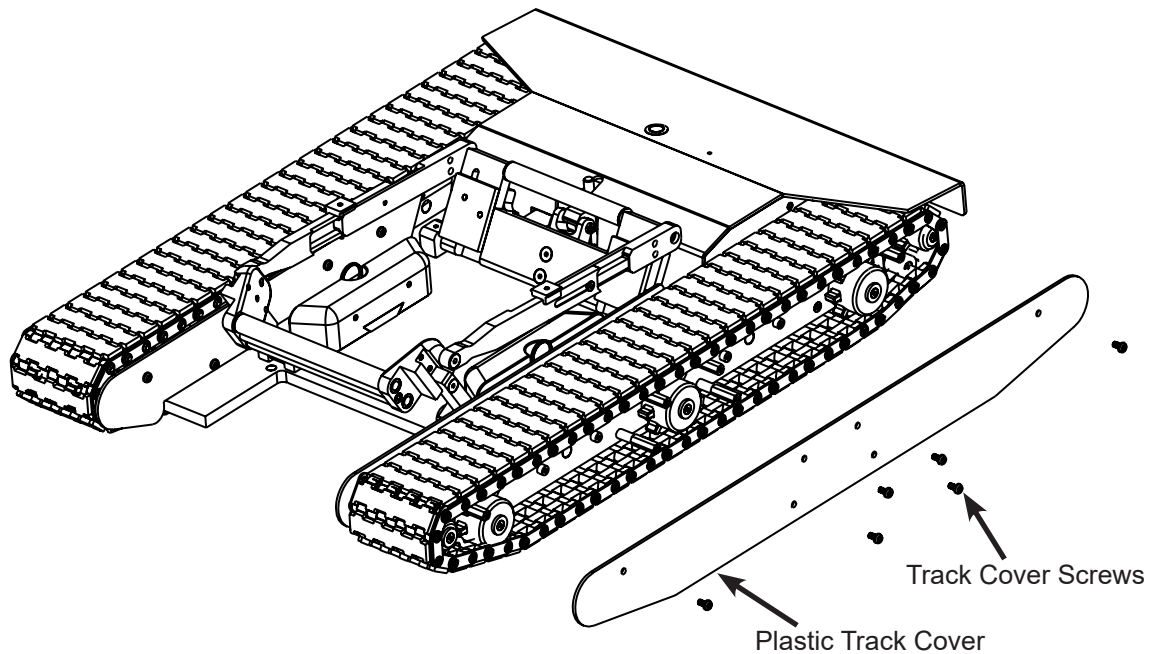

2. Loosen three front rail end retainer screws. It may be necessary to rotate the large sprocket to get to one of the retainer screws.

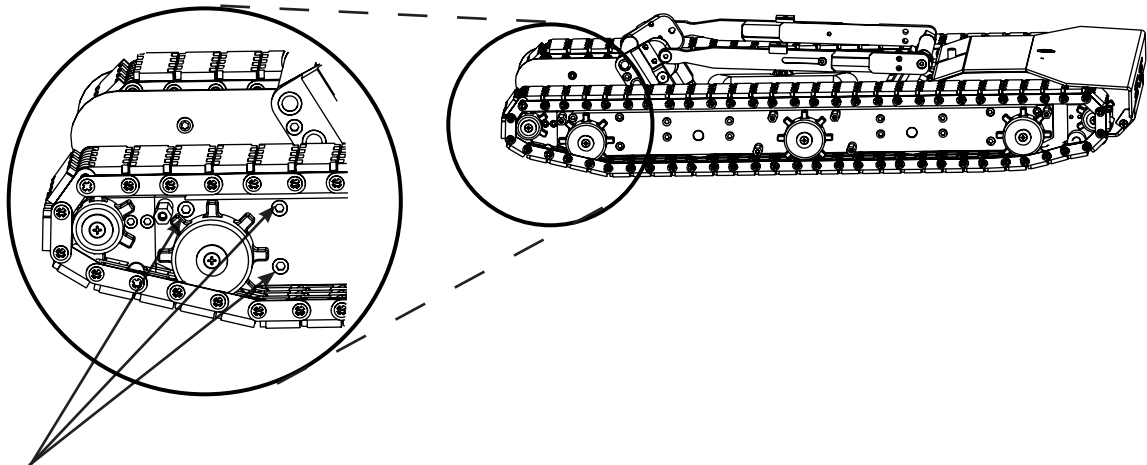

3 Retainer Screws  
on outer Side of Rail

3. Push the rail end forward using a small pry bar to tighten up the track. There should be about a 1/2" of play at the center of the track.

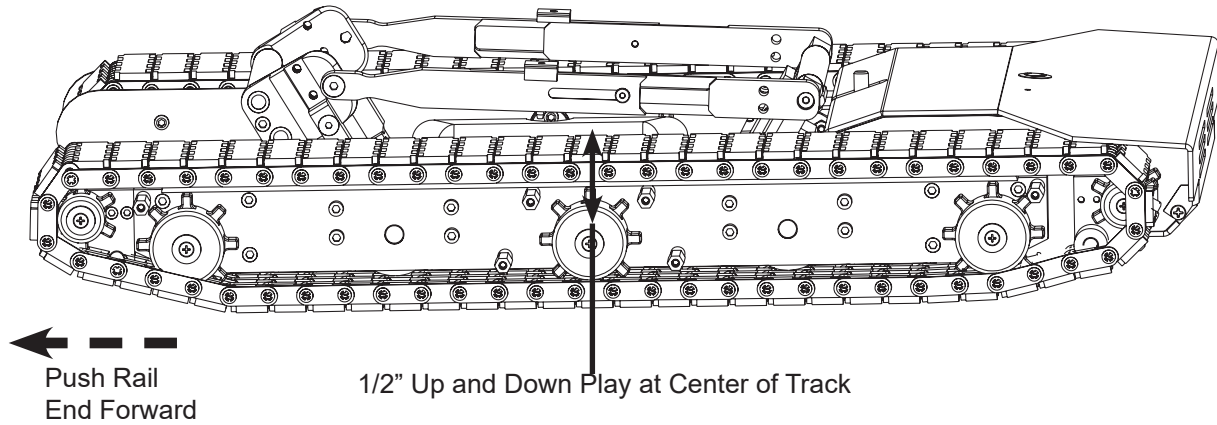

4. Tighten up all 3 retainer screws and reinstall the plastic track covers.

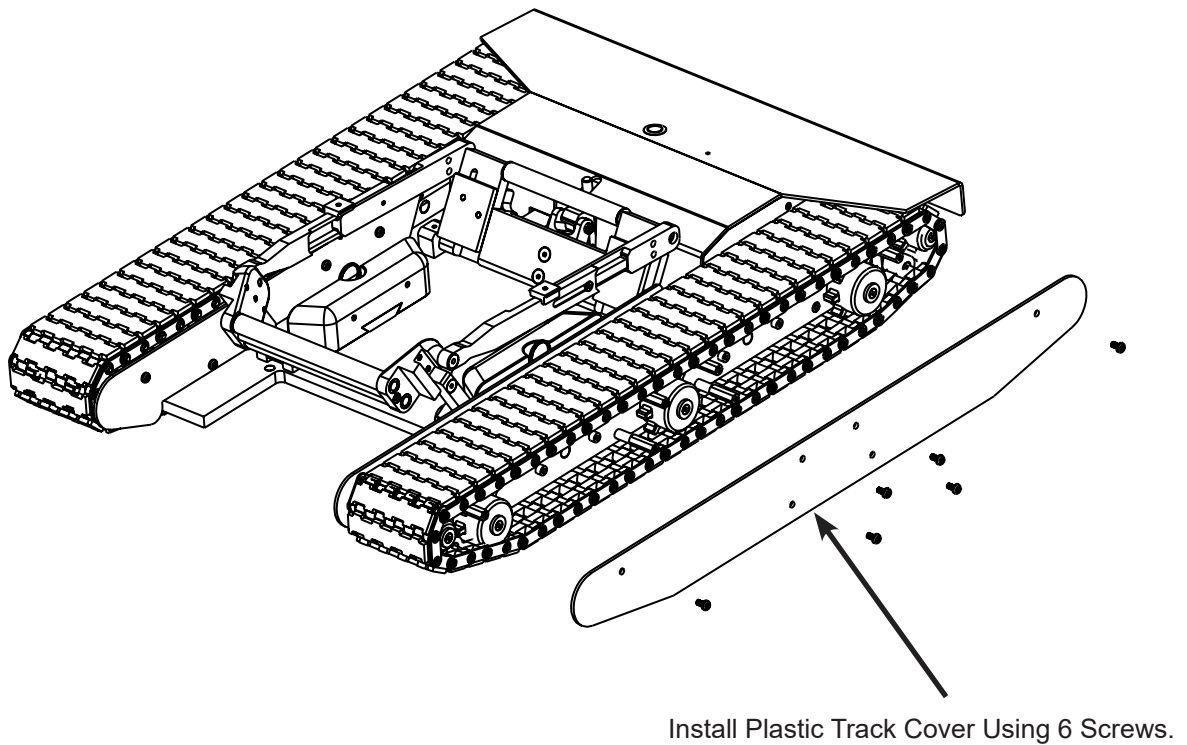

5. Repeat steps 1 through 4 for the other track.

## 2. Start Up Guide

### 2-6 Loading the Aircraft Wheel

1. Turn the tug power ON and the radio power ON.
2. Use the latch release switch on the remote controller to lower the wheel cradle.
3. Drive the tug positioning it just in front of the wheel. Some tail draggers can be approached from the front or the back depending on the wheel configuration
4. Drive the tug under the wheel at a moderate speed, no need to get a running start.
5. The wheel will roll up onto the tug and will push the back gate of the cradle to the latched position.

Note: It may be necessary to apply a little pressure with your foot to the top of the electronics cover to get the wheel started onto the tug.

6. Drive the tug in the forward or backward direction to maneuver the airplane to its desired location. Be cautious of the steering angle limitations of your aircraft. Do not oversteer your aircraft with the tug. This can cause damage to your gear.
7. The circuit breaker reset buttons will trip if the tug is overloaded. This will cause the tug to be unresponsive to the remote controller. To reset the circuit breaker open the electronics cover and locate a two white or black button on the circuit board. See image below. Press it down to reset the circuit breaker.

#### Critical Note:

If the circuit breaker buttons pop up after being reset, the tug is being overstressed and could cause damage to the circuit board. Address any mechanical issues such as a seized sprocket or missing track retainer clips or any driving conditions such as driving up a steep incline or towing above the tugs capacity that could be causing the tug to overstress. If the issue persists call or e-mail AC Air Technology tech support for further assistance.

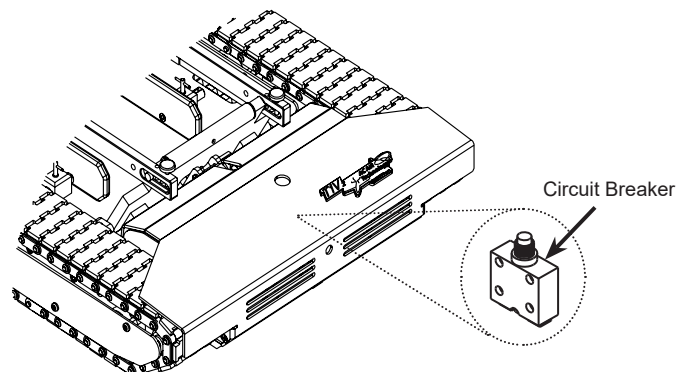

## 2. Start Up Guide

### 2-7 Unloading the Airplane Wheel

1. Turn the tug power ON and the radio power ON if not already on.
2. Push the tug slightly forward so the airplane tire puts pressure on the back gate of the cradle.

The back gate is the gate that is closest to the latch mechanism.

3. While holding a slight pressure on the back gate release the latch by holding the latch release button on the radio.
4. While still holding the latch release button move the tug away from the tire.
5. The front gate should go down and the airplane tire will roll out of the cradle.

## 2. Start Up Guide

### 2-8 Lifting the Wheel Cradle Ramp

The cradle shims are used to lift the wheel cradle ramp away from the ground. When traversing over very uneven terrain the wheel cradle ramp may hit the ground and prevent the aircraft from loading onto the tug.

There are two setups depending on whether you need the shims permanently (A) or occasionally (B).

#### Setup A: Installing Shims Permanently

1. The cradle shims and mounting screws are located in the on-board parts box underneath the electronics cover. Pull to open magnetically held cover.

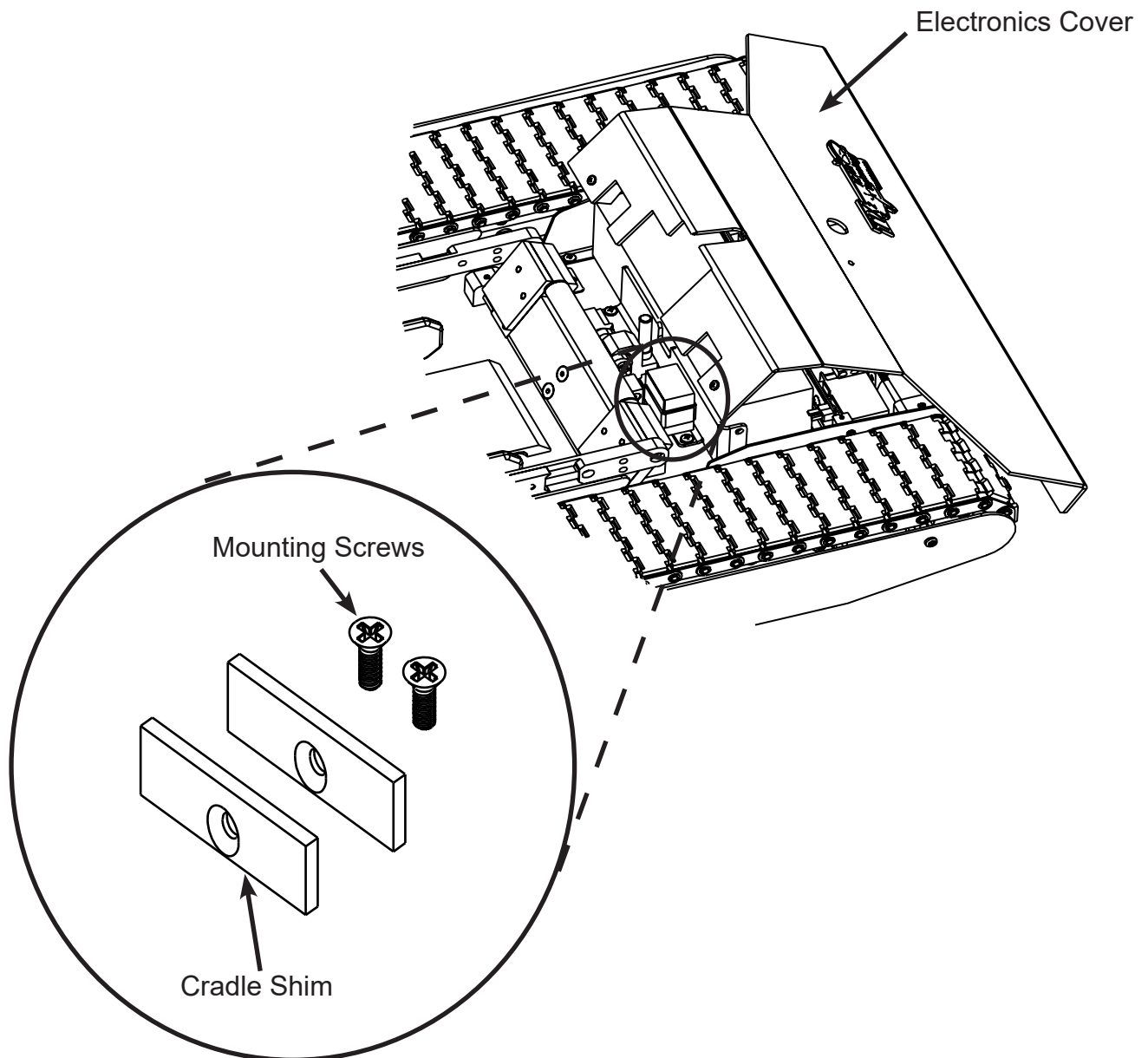

- 2. Install the cradle shims onto the Cradle Front Adjusting Arms. Apply thread-locker to the screws to prevent them from vibrating off. Note the orientation of the shim with respect to the cradle front adjusting arms. There should be a small gap between the cradle front adjusting arm and cradle shim as shown below.

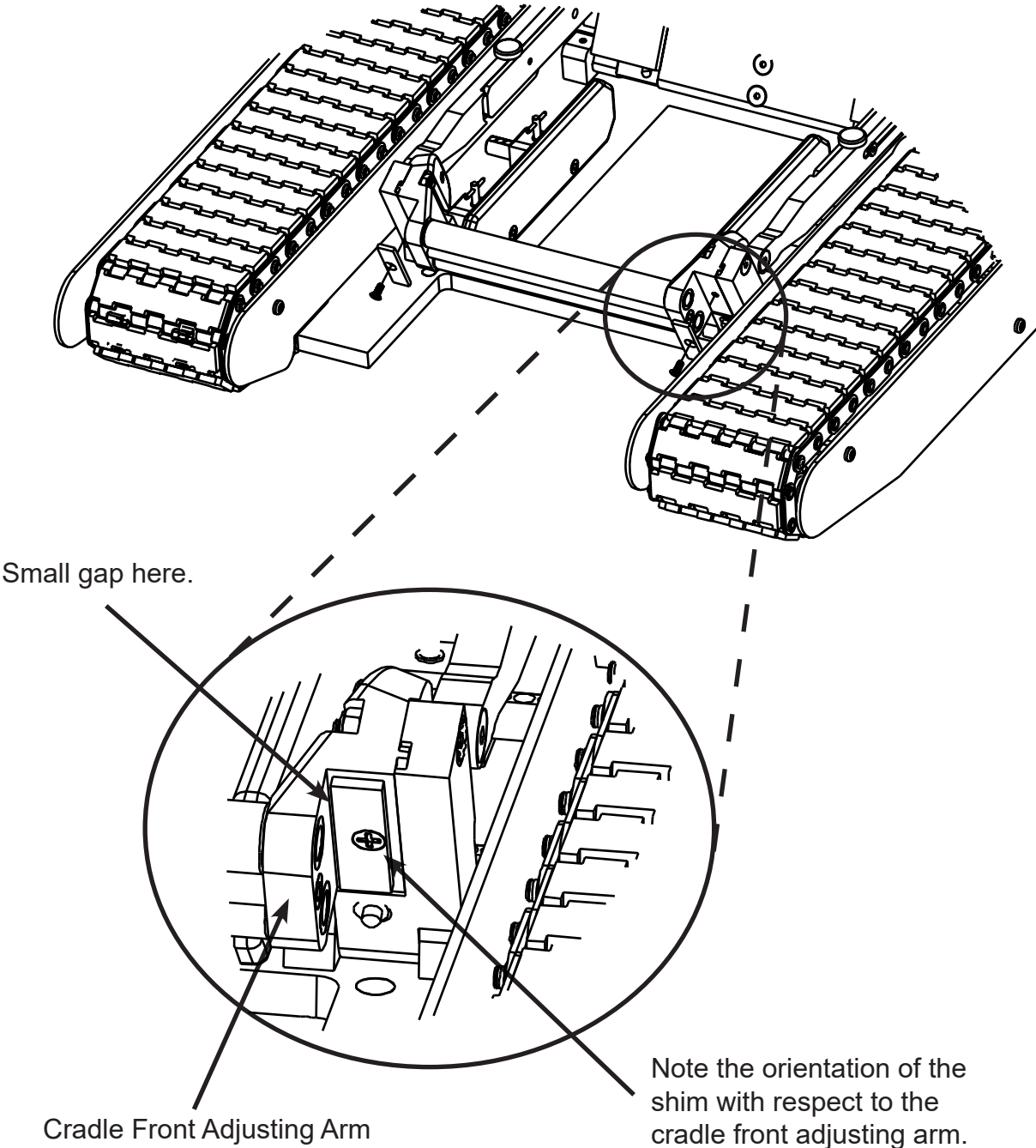



## Setup B: Installing Shims for Occasional Use

1. The shims and mounting screws (with attached lock washer) are located in the on-board parts box underneath the electronics cover. The electronics cover is held down magnetically, pull the cover to open.

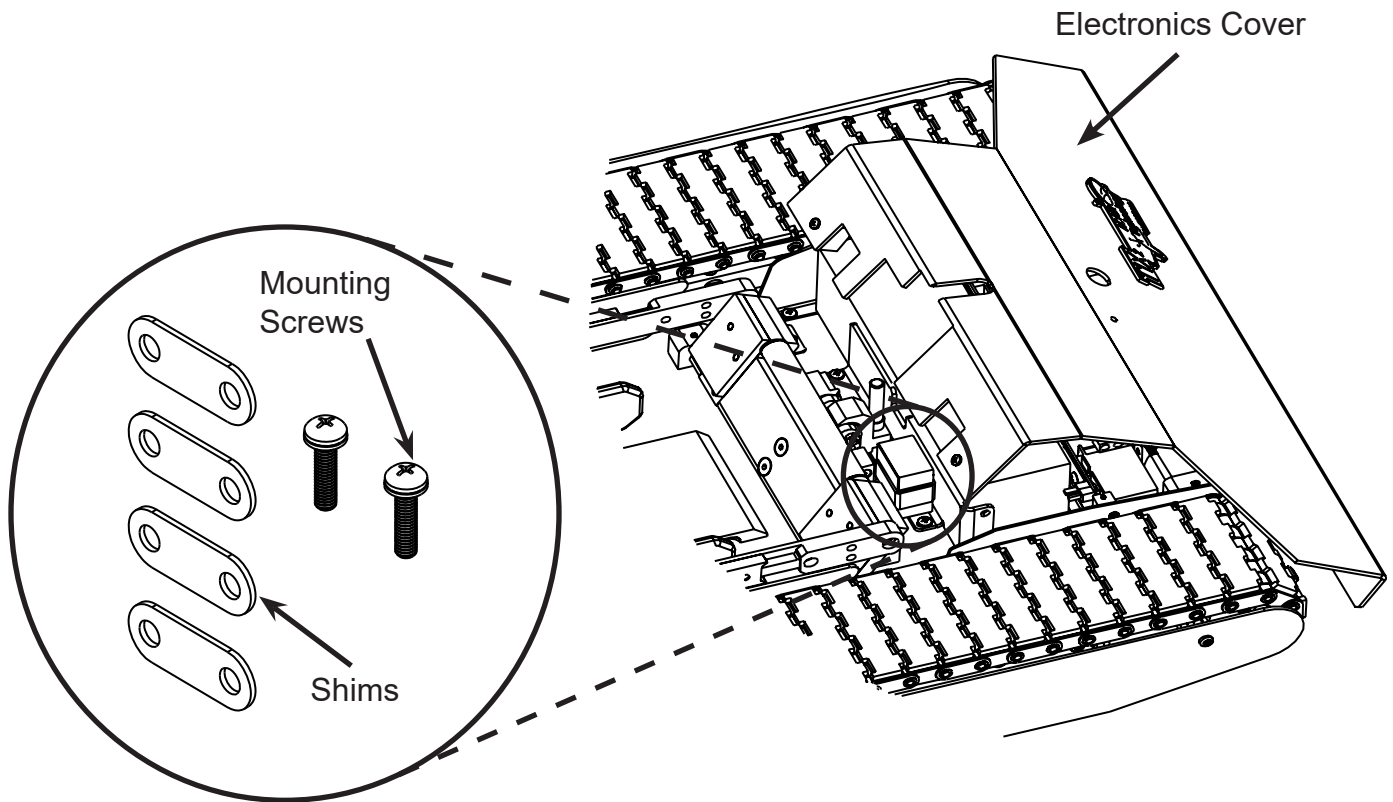

2. With the wheel cradle in the “Up” latched position, install the shims onto the tug mainplate threaded holes located near the loading end. Two shims and one mounting screw per side.

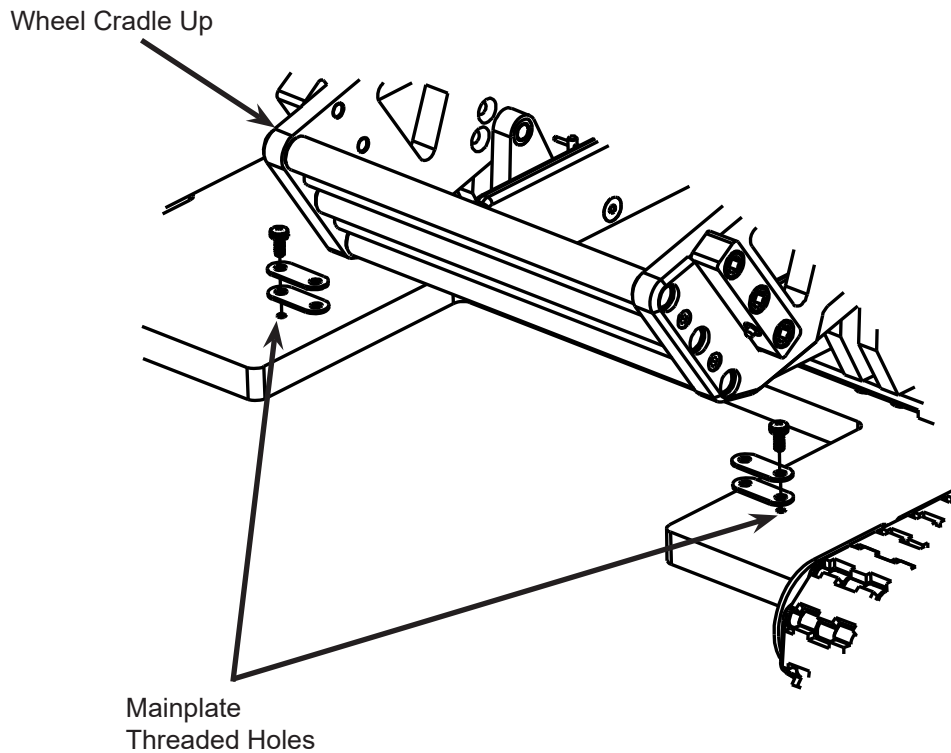

3. Both left and right side shims should be engaged if in the ON position or both sides should be disengaged if in the OFF position to prevent the cradle from twisting.

In the ON position, the wheel cradle should land on the shims lifting the wheel cradle ramp away from the ground.

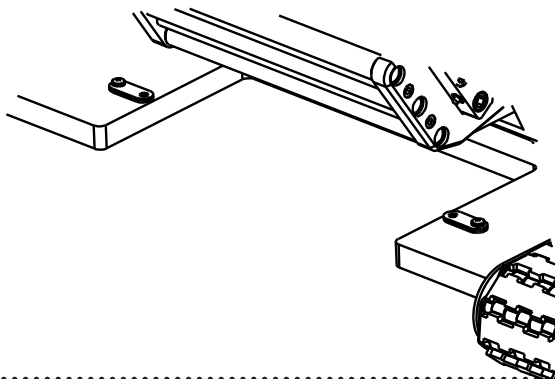

Loosen the mounting screws and rotate 180 degrees to the OFF position when not needed. Tighten screws to secure.

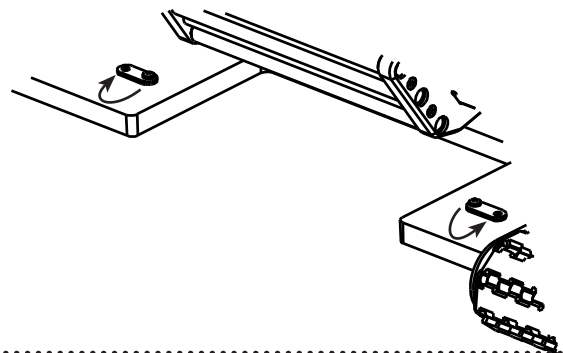

## 2. Start Up Guide

### 2-9 Charging the Tug

1. Before charging your tug, the remote controller and tug should both be turned OFF.

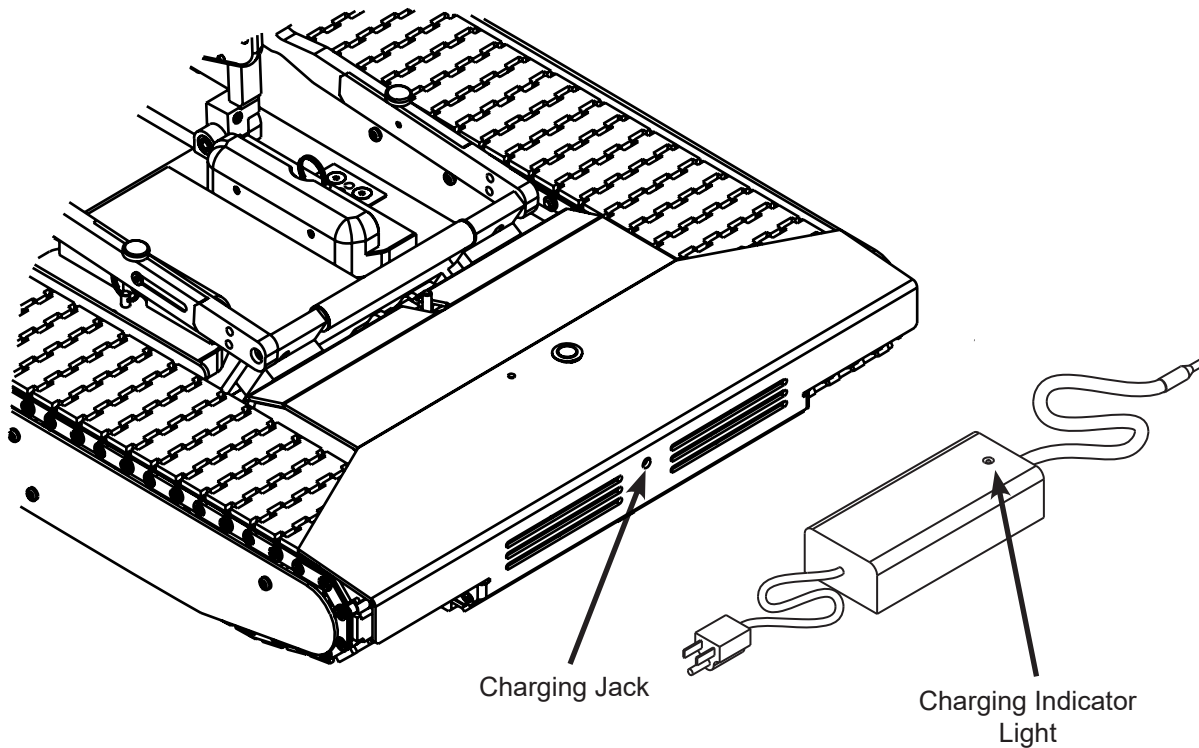

2. Normal charger indicator lights:
  - Red.....Charging
  - Solid Green.....Fully Charged
  - Flashing Green.....No Longer Charging
3. Leave the tug charging when it is not in use. The charger is equipped with “smart” charging technology, preventing the battery from overcharging. Keeping the tug on its charger will prolong the life of the battery.

## 2. Start Up Guide

### 2-10 Charging the Remote Controller

**WARNING: Only use the supplied charger to charge the controller when using the supplied batteries or the following:**

- 1200mAh to 2200 mAh Ni-MH or Ni-Cd 'AA' Rechargeable Batteries

**Using the remote control charger with alkaline batteries installed can damage the controller. Do not use the charger if alkaline batteries are installed in the controller.**

1. Plug the transmitter charger into a 110v AC wall socket.
2. Plug the connector from the charger into the charging jack on the transmitter. The charging indicator LED, located on the side of the transmitter, will illuminate green indicating the charger is charging. Once the transmitter is fully charged the charging indicator LED will turn off.
3. The charging rate of the charger is 150mAh. When using the 1200mAh batteries that are supplied, the radio requires an 8 hour charge when fully discharged ( $1200/150=8$ ). If using 2200mAh batteries, it will take approximately 15 hours to charge ( $2200/150=14.6$ ).

**It is recommended to leave the remote controller charging when not in use.**

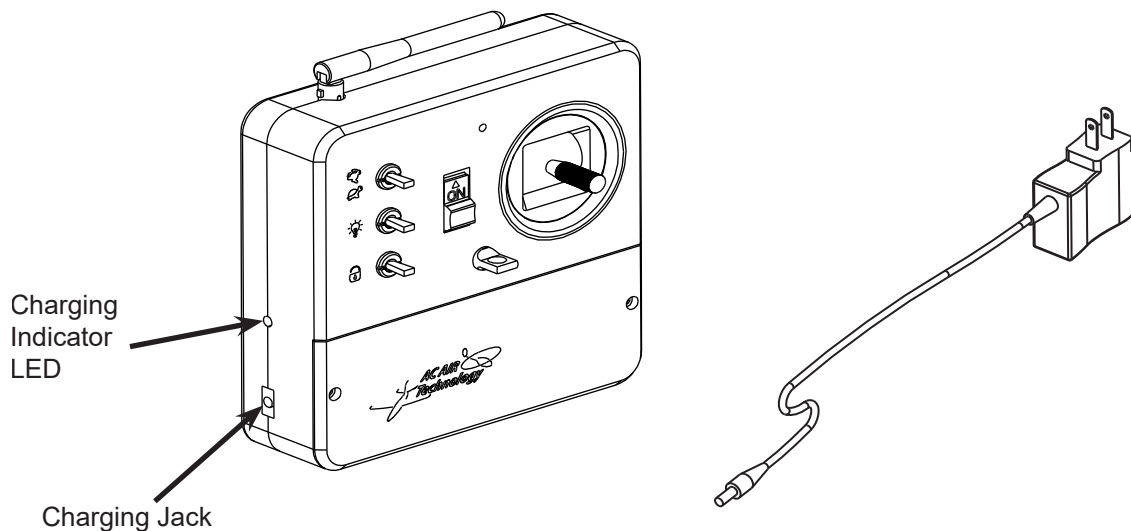

## 2. Start-Up Guide

### 2-11 Replacing the Remote Control Batteries

1. Before changing the remote control batteries, the remote controller and tug should be turned OFF.
2. Remove 2 screws on the back cover of the remote controller then remove the back cover.

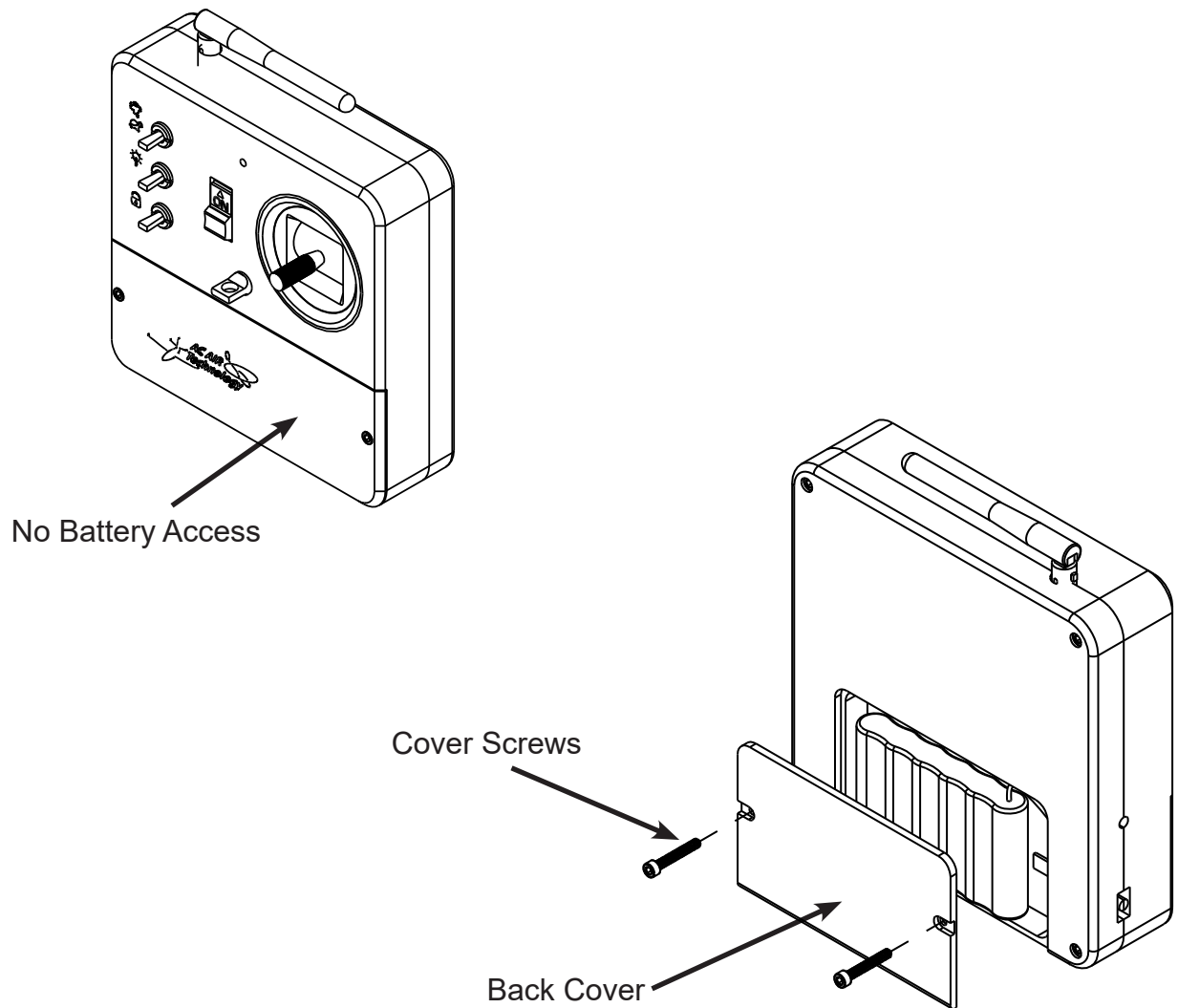

The transmitter batteries are set up like A or B shown below:

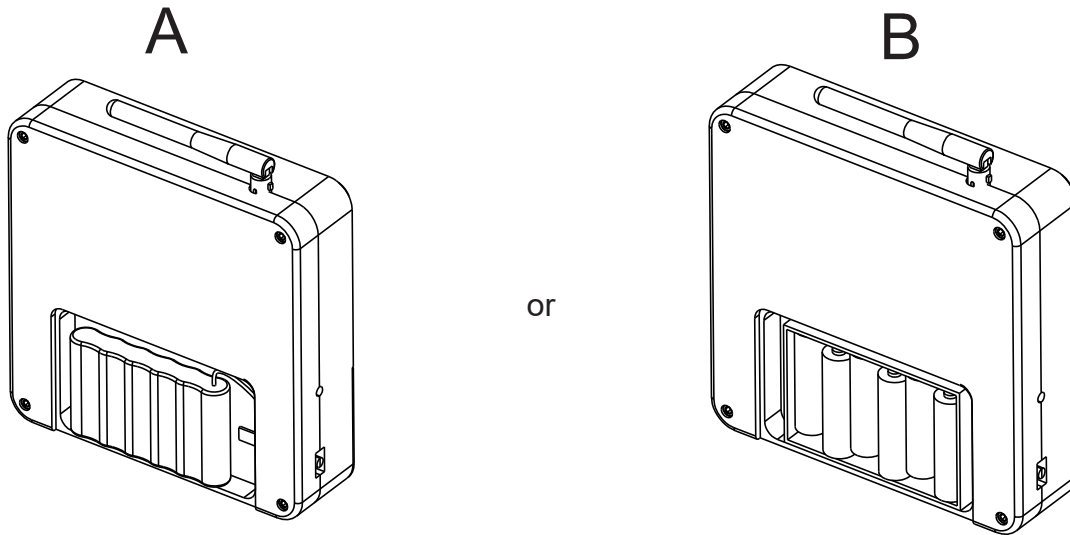

**A. A shrink wrapped battery pack**

3A. Disconnect the shrink wrapped battery pack and remove the battery.

4A. Replace the batteries by purchasing a new shrink wrapped battery pack from AC Air Technology or installing the supplied battery tray and purchasing 6 rechargeable 'AA' Lithium Ion batteries. Refer to section 2-9 in the owners manual

5A. Reconnect the battery to the transmitter circuit board.

6A. Re-install back cover and screws.

**B. A battery tray with 6 rechargeable 'AA' Lithium Ion batteries**

3B. Remove the 6 batteries and replace with new rechargeable 'AA' Lithium Ion batteries. Refer to section 2-9 in the owners manual.

Note: A shrink wrapped battery pack can be purchased from AC Air Technology to replace the installed battery tray. To use a shrink wrapped battery pack:

1. Disconnect the battery tray from the transmitter circuit board.
2. Connect the new shrink wrapped battery pack to the circuit board.

4B. Re-install back cover and screws.

Battery Tray

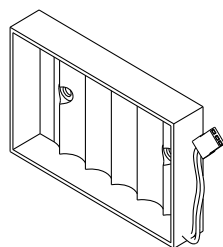

### 3. Stowable Feature

#### 3-1 Disassemble Tug

1. With the wheel cradle in (up) locked position, lift the front-end of the tug and slide the provided foam stand underneath the tug. The foam stand has the following dimensions, 19" x 11" x 2-1/4". It is stored in the shipping box, foam packaging)

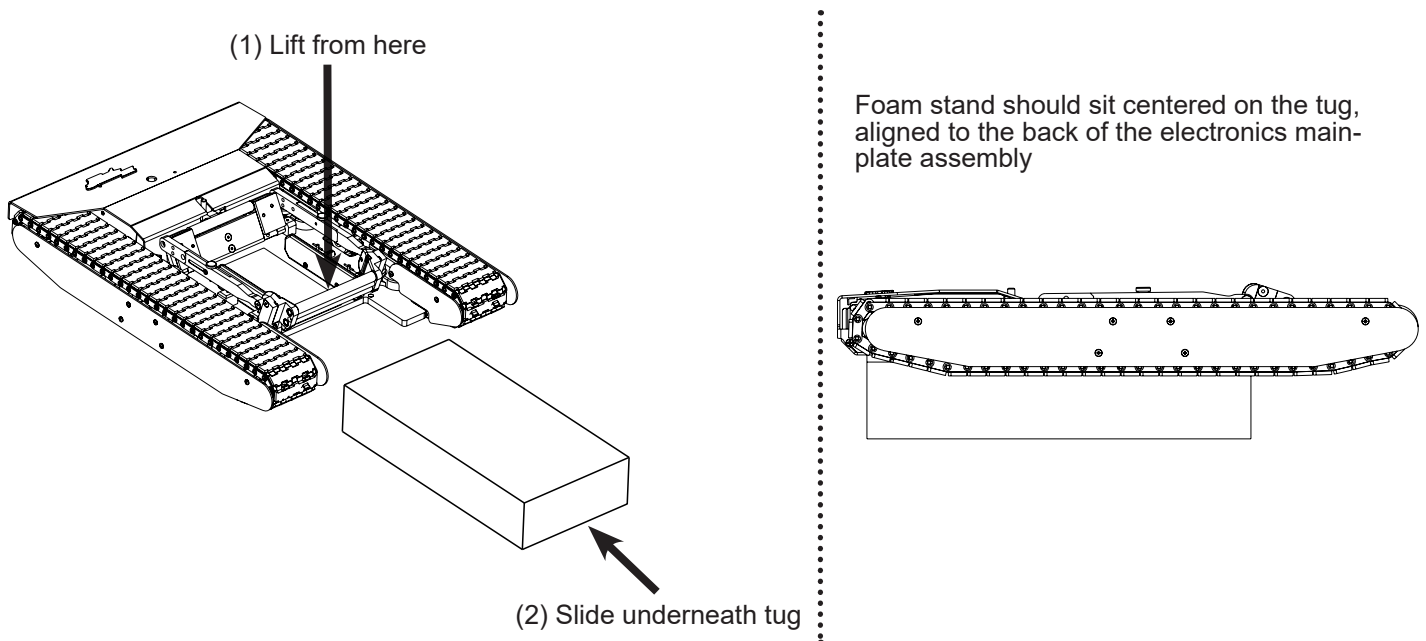

2. Open the electronics cover. Locate 4 quarter-turn fasteners, 2 per rail-track assembly.

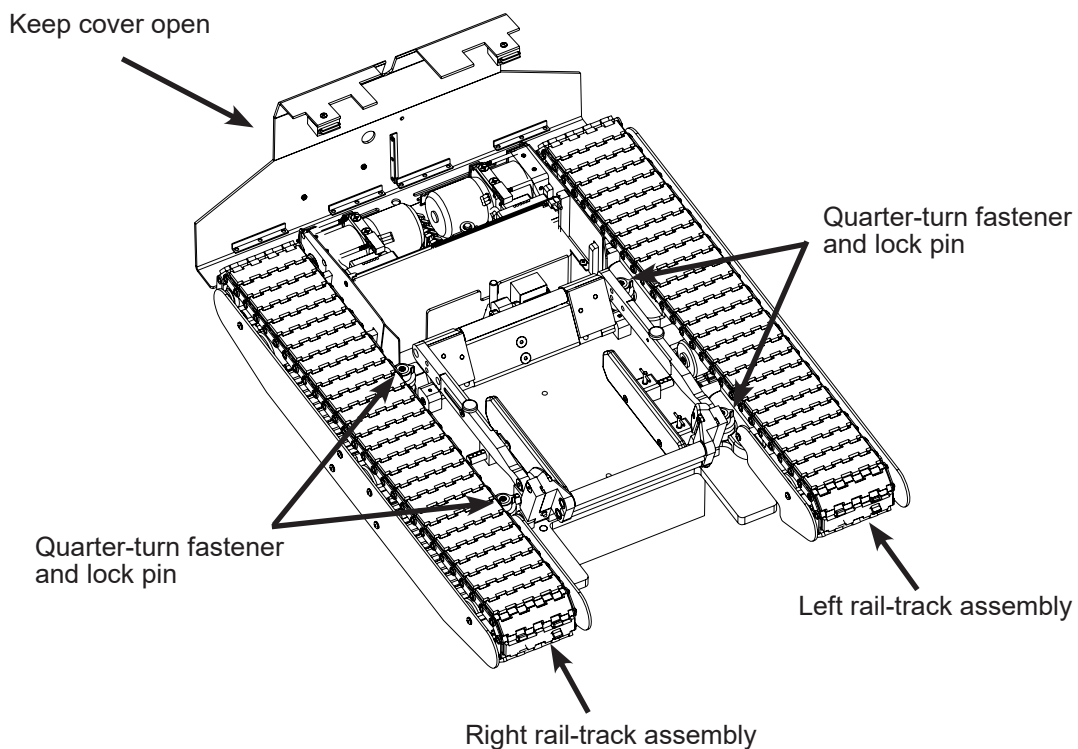

3. With one hand, apply pressure upward on the bottom, center, of the rail-track assembly to relieve pressure off the rail-track assembly lock pin. Turn the quarter-turn fasteners (90 degrees), 2 per side. The quarter-turn fasteners should be easy to turn once the pressure is off the lock pin. **Do not force the lock pins out.**

Keep cover open

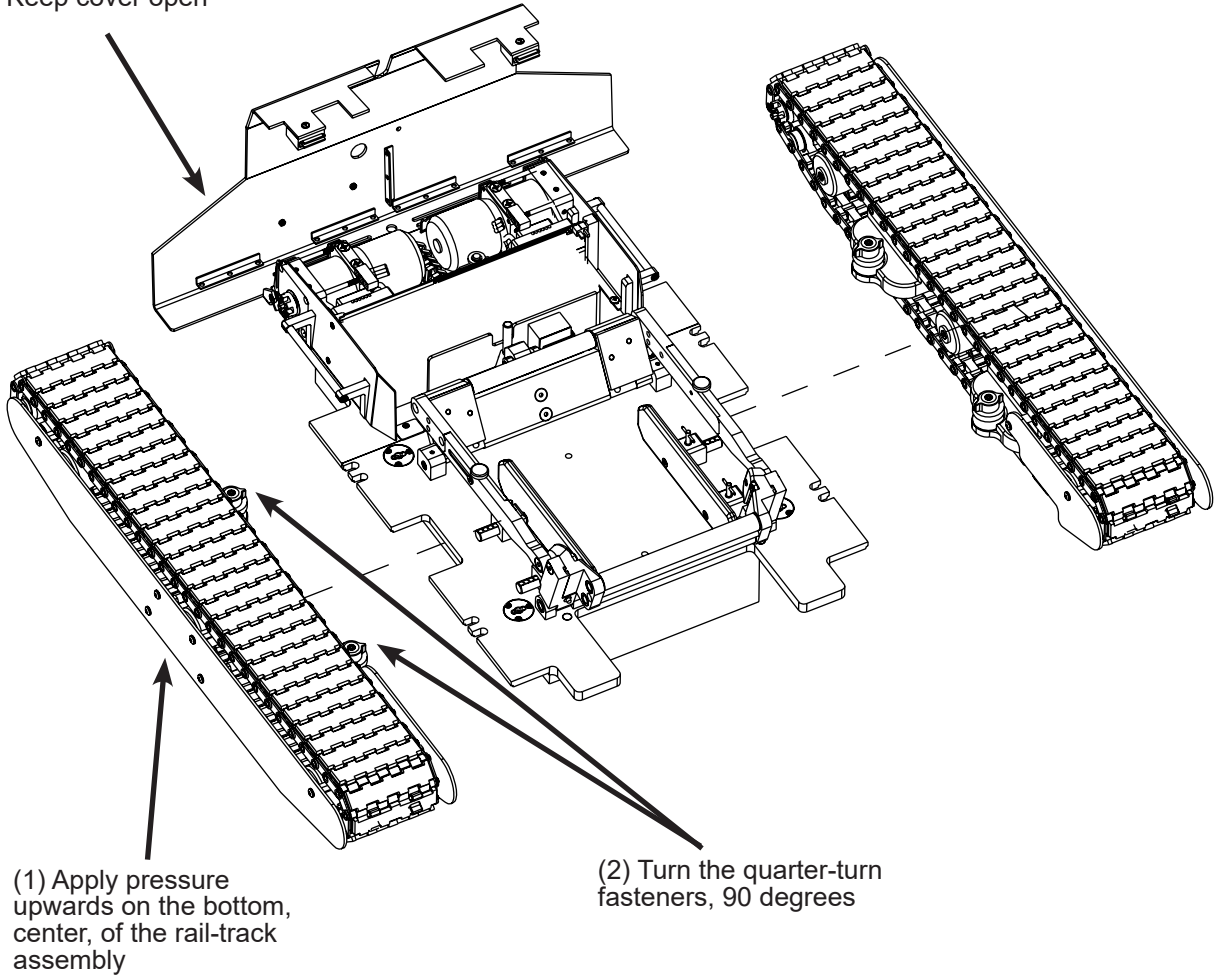

4. Repeat for the other side.



5. Manually unlatch the wheel cradle and place it in (down) loading position.

6. With the cover open, hold the electronics mainplate assembly by the handles. Slightly tilt the assembly forward and slide it to the right until the connection tabs are in the unlocked position.

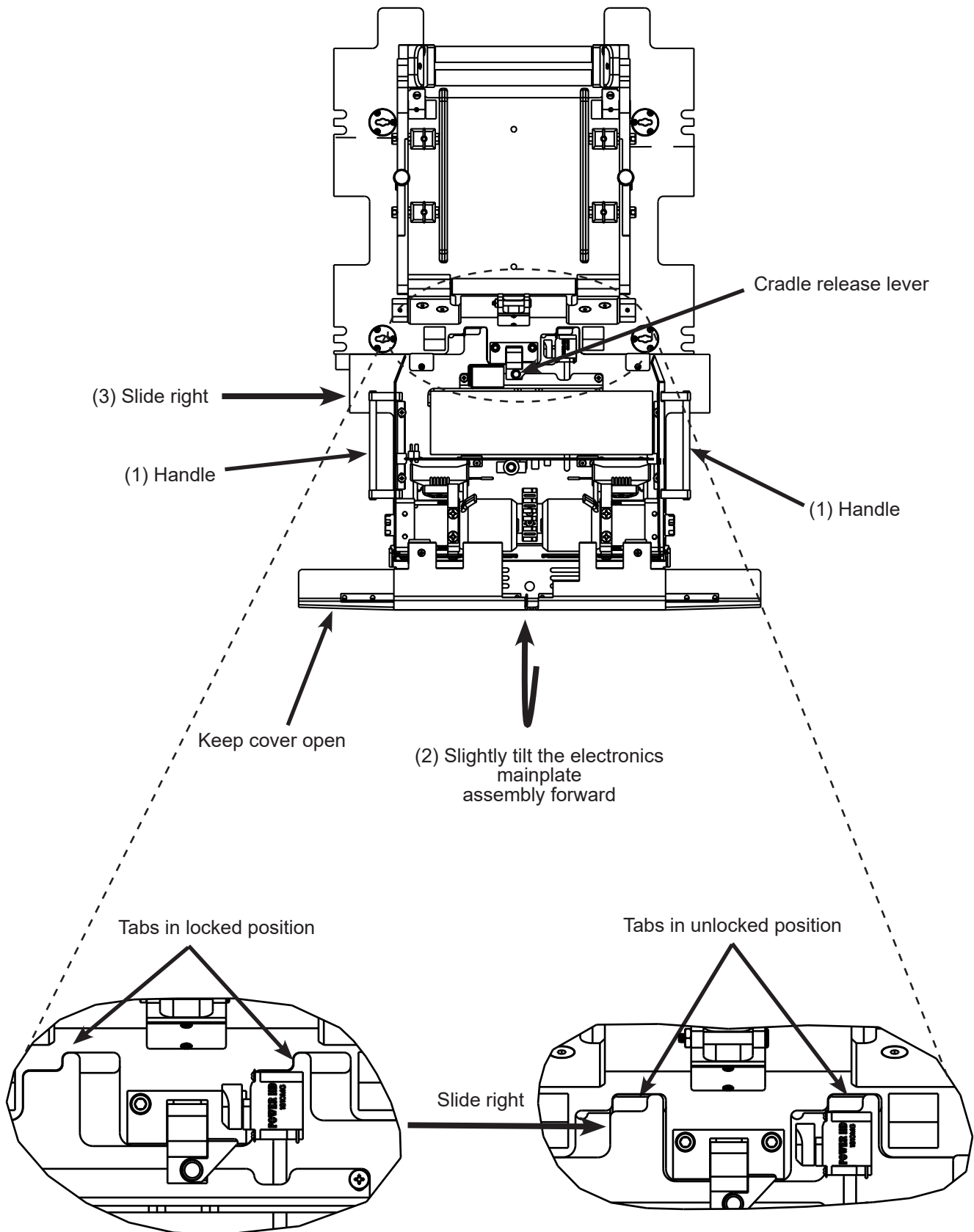

- Lift the electronics mainplate assembly straight up. Always use both handles when maneuvering the electronics mainplate assembly.

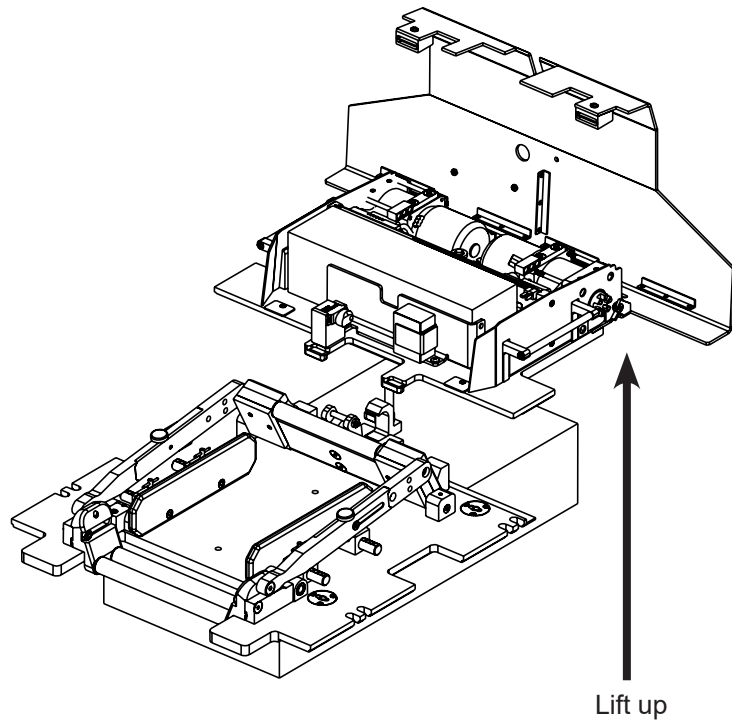

Note: Weight per subassembly

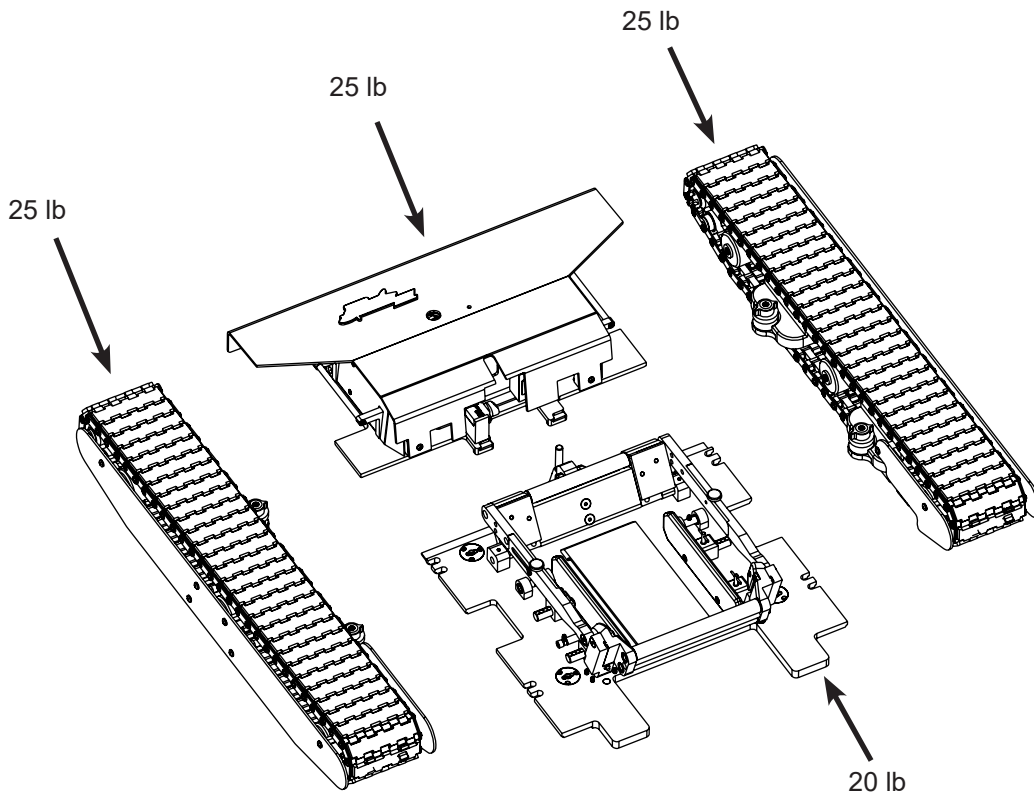

### 3. Stowable Feature

#### 3-2 Reassemble tug

1. Place the cradle mainplate assembly on top of the foam stand. The foam stand has the following dimensions, 19" x 11" x 2-1/4". It is stored in the shipping box, foam packaging
2. **Manually unlatch** the wheel cradle and place it in (down) loading position.

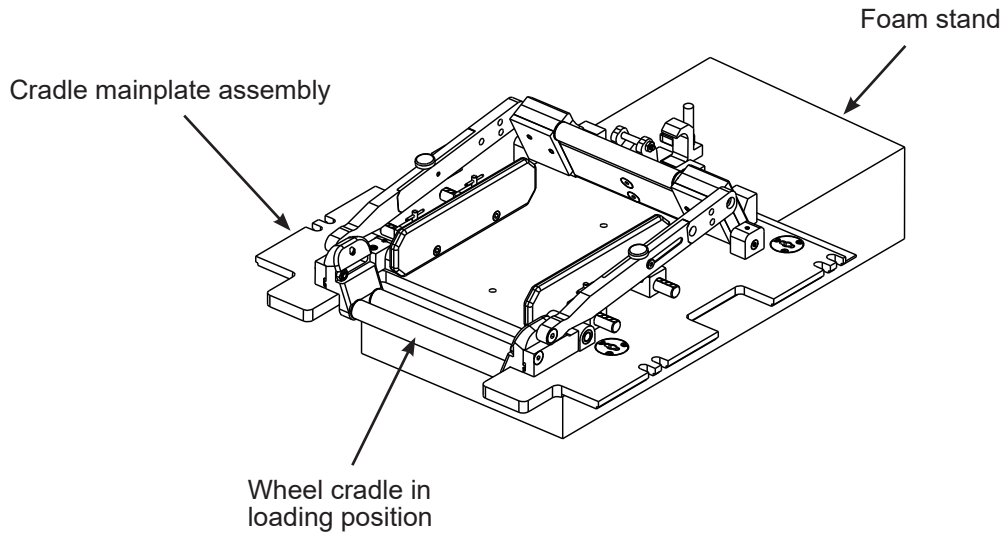

3. Open the electronics cover and hold the electronics mainplate assembly over the cradle mainplate assembly using the handles. Align the edges and tabs with the slots in the cradle mainplate assembly. Seat the tabs into the cradle mainplate assembly slots.

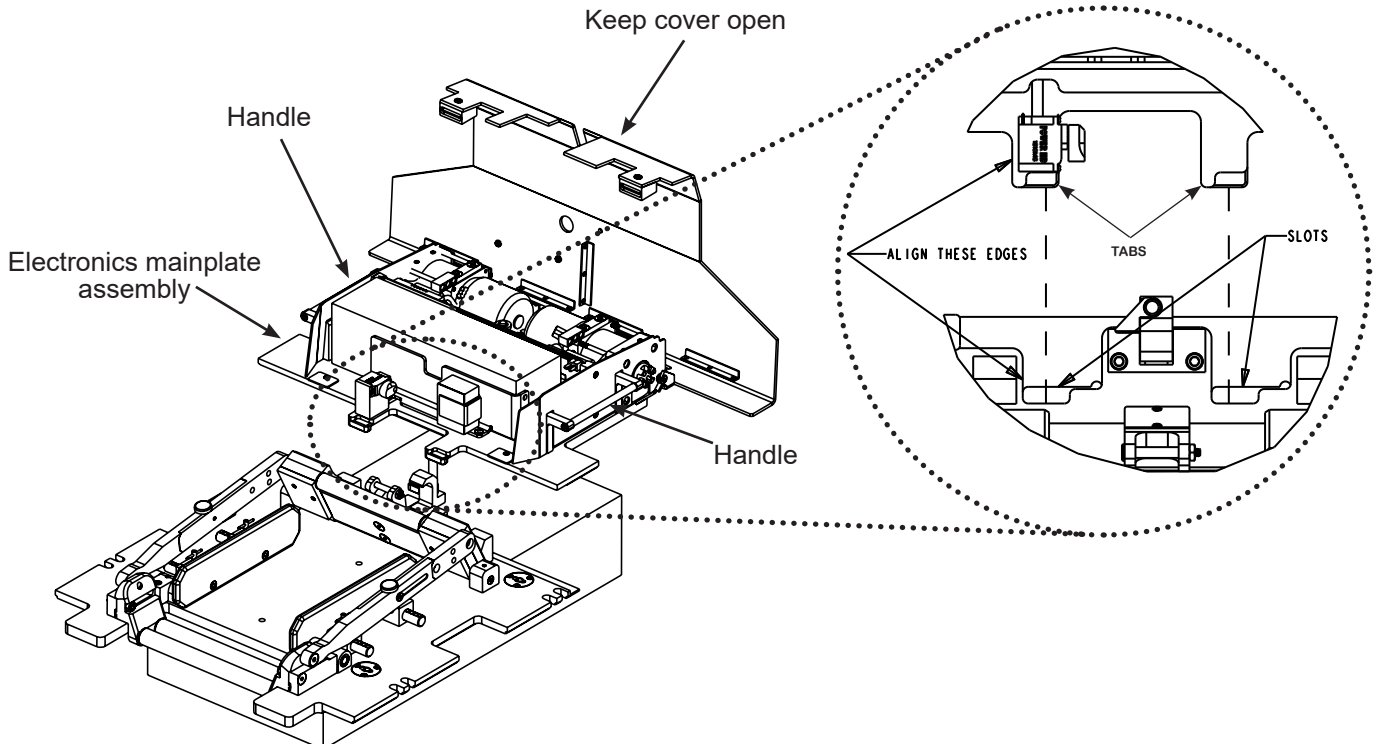

4. Slightly tilt the electronics mainplate assembly forward and slide it to the left until the connection tabs are in the locked position. Check the latch and cam for proper seating.

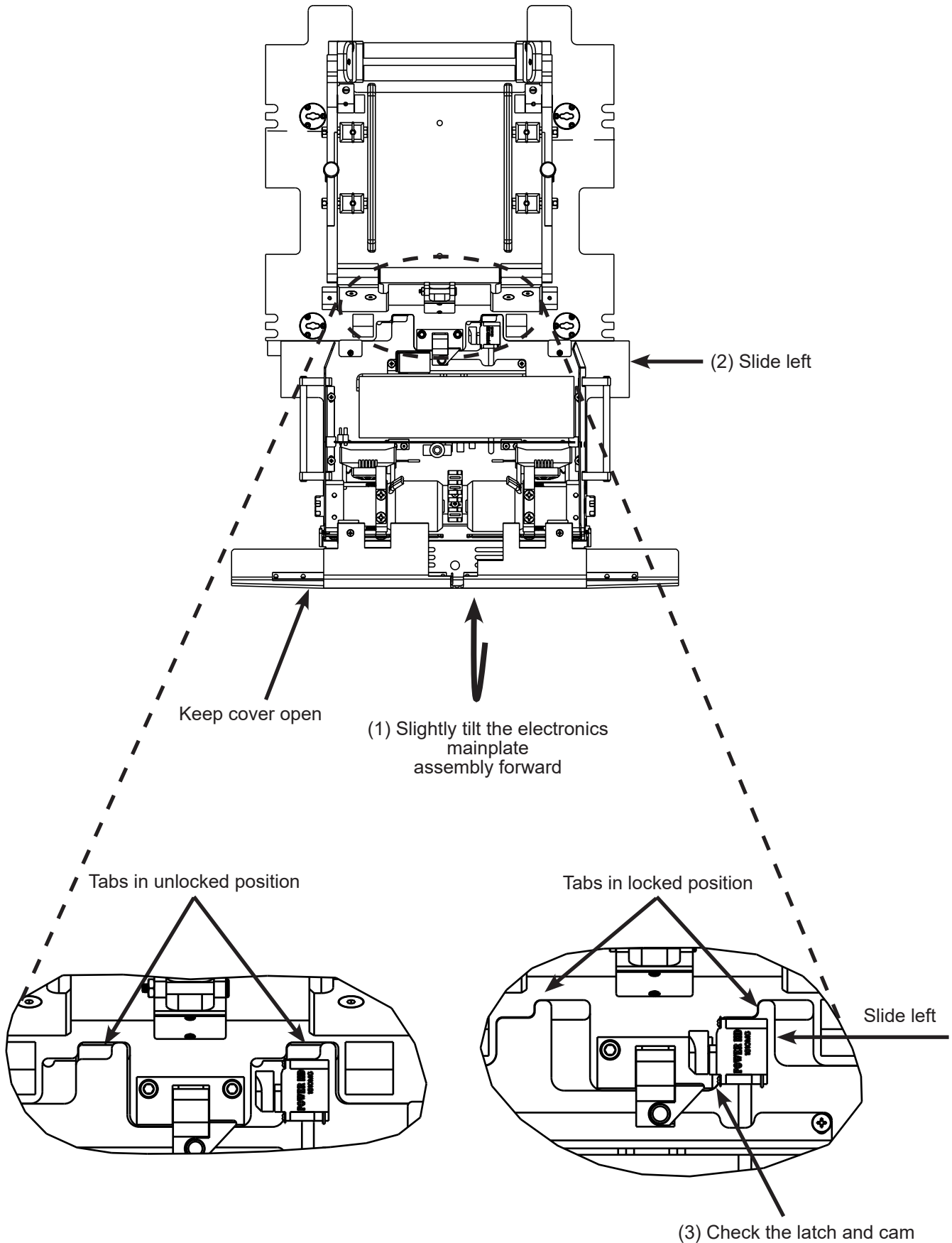

5. Align the shaft teeth, rotate the motor by hand if the teeth are not engaging correctly.
6. Align the quarter-turn lock pin fasteners with its respective receptacle.
7. Apply pressure upwards on the bottom, center of the rail-track assembly and press the quarter-turn fastener down into the receptacle. Turn the quarter-turn fasteners (90 degrees) to lock the rail-track assembly in place.

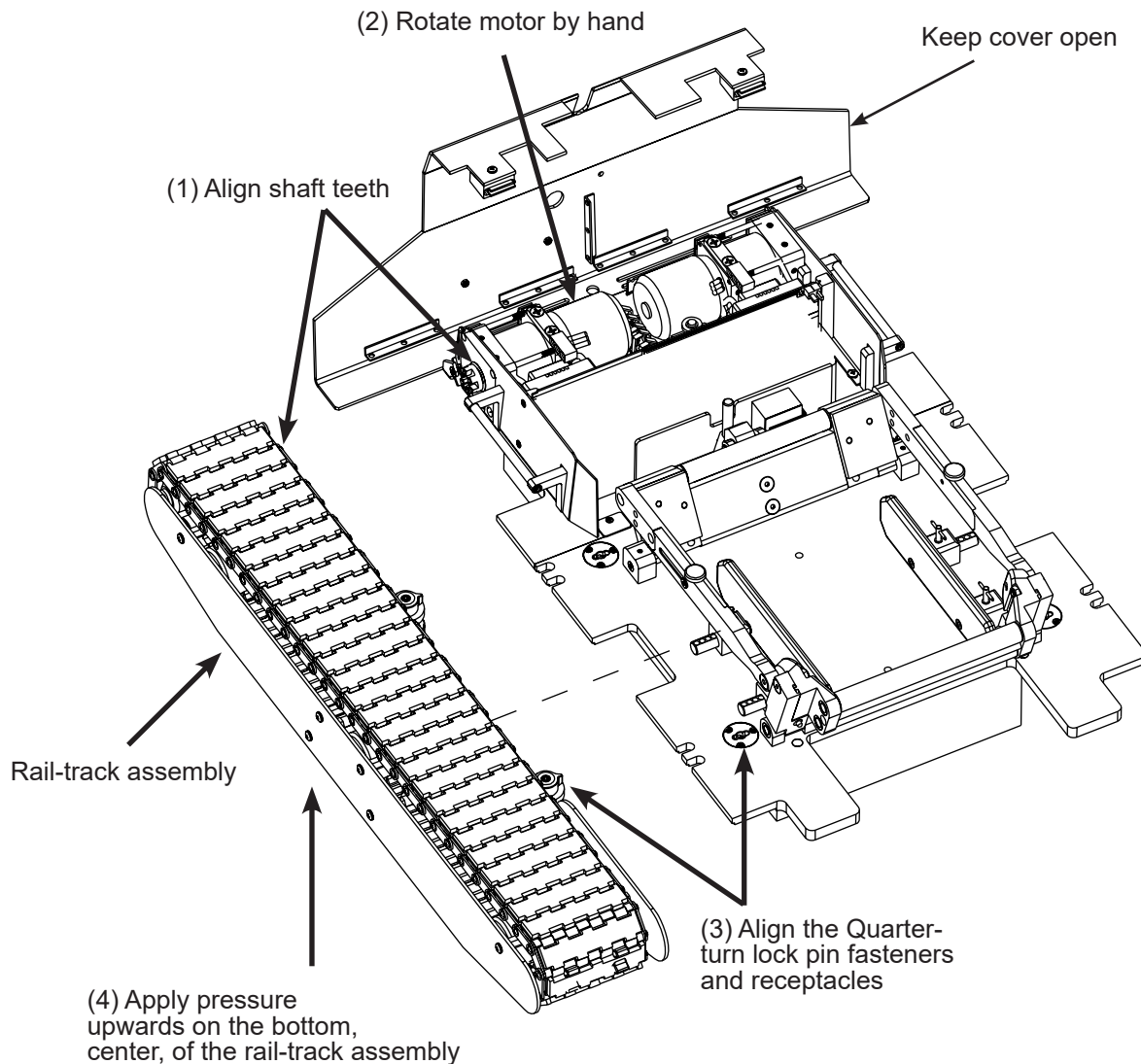

8. Ensure the quarter-turn fasteners are fully engaged. The quarter-turn fasteners should not rotate from their locked position when properly fastened.
9. Repeat for the other side.
10. After lifting the tug off of the ground for any reason or taking it in and out of your aircraft, you must check to make sure the sprockets are correctly seated on the tracks. If the sprocket is not properly seated it could result in damage to the tracks.

## 4. Troubleshooting

The troubleshooting guide is divided into three sections: Tug, Remote Controller, Wheel Cradle. Refer to the images and descriptions below as they are mentioned throughout the text.

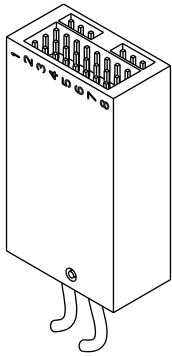

Radio Receiver

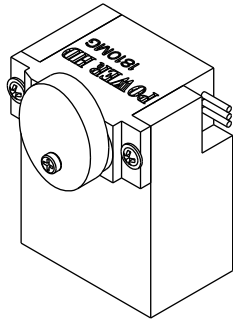

Servo

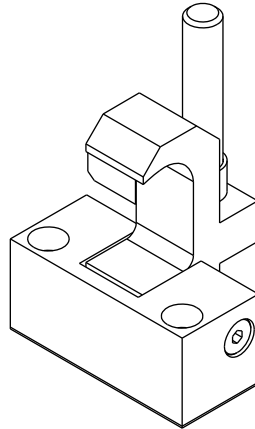

Latch Mechanism

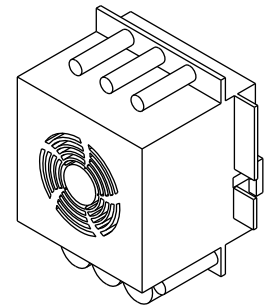

Speed Control

For technical support call or email

AC Air Technology  
(855) 884-7222  
[info@acairtechnology.com](mailto:info@acairtechnology.com)

Tug			
Symptom	Cause	Action	Detail
Tug beeps 3 times	Tug is ON	No action required	Tug will beep when initially turned on
	Battery voltage is getting low	Charge tug battery	Tug charger indicator light will illuminate red when charging and green when fully charged.  Tug will beep when the battery voltage is below 28 volts (power button flashing red). It is recommended to keep the tug and remote controller charging <b>when not in use</b> .
	Tug is momentarily overloaded	Turn the tug power button OFF then ON again to reset the PC Board.	Steep inclines, turning the tug underneath the wheel without any forward/backward motion, and sudden stops can cause the tug to signal a momentary overload.
Tug beeps continuously	Battery voltage is below operable voltage	Charge tug battery or Replace battery if it does not hold a charge  With a voltmeter, check tug charger output voltage for 29.4 volts. Replace charger if it does not output the correct voltage	Tug power button light will blink red.  Tug charger indicator light will illuminate red when charging and green when fully charged.  It is recommended to keep the tug and remote controller charging <b>when not in use</b> .
Tug indicates a full charge soon after it is plugged into the charger	Charger has failed	Replace tug charger	Tug charger indicator light will illuminate red when charging and green when fully charged
Tug does not turn on	Battery is not plugged into the PC Board	Turn off the remote controller and tug. Open the magnetic tug cover and plug the battery into the PC board. Ensure the connection is fully engaged.	During shipping the battery connection can become loose or disengage from the PC board.
	Battery voltage is below operable voltage	Charge tug battery or Replace battery if it does not hold a charge  With a voltmeter, check tug charger output voltage for 29.4 volts. Replace charger if it does not output the correct voltage	Tug charger indicator light will illuminate red when charging and green when fully charged.  It is recommended to keep the tug and remote controller charging <b>when not in use</b> .
Tug does not respond to remote controller	Battery is low on remote controller or tug	Charge the battery on remote controller or tug	Tug charger indicator light will illuminate red when charging and green when fully charged.  Remote controller charging indicator light, located on the side of the remote, will illuminate green when charging and light will turn off then fully charged.  It is recommended to keep the tug and remote controller charging <b>when not in use</b> .
	Tug is overloaded	Reset the circuit breaker(s). Turn off the remote controller and tug.	Steep inclines, towing above the tug's capacity, and sudden stops can cause the tug to activate the circuit breaker.

	Tug is overloaded (continued)	Open the magnetic tug cover and locate the circuit breaker(s) on the PC board. Press the button(s) down to deactivate the circuit breaker (If it is active you will feel some resistance from the button). See the critical note in the "Details" section.	CRITICAL NOTE: If the circuit breaker continues to activate after being reset, the tug is being overstressed and could cause damage to the circuit board. Address any mechanical issues, such as a seized sprocket or missing track retainer clips or any driving conditions, such as driving up a steep incline or towing above the tugs capacity that could cause the tug to overstress. If the issue persists, call or email AC Air Technology tech support for further assistance.
	Remote controller and receiver are not binding	Rebind remote controller and receiver.	Call or email tech support for further assistance
One track turns but the other track does not	Speed controls are not plugged into radio receiver correctly	Turn off the radio controller and tug. Open the magnetic tug cover. Visually inspect the wire from the speed control to the receiver on the PC board for any damage. If there is damage, replace the speed controls.  Verify that the wires from the speed controls are connected to slot numbers 1 and 2 on the receiver. Ensure the connections are fully engaged	If there is damage to the speed controls, the PC board may need to be replaced. Call tech support for further assistance.
	Gearbox failure	Open the tug cover and visually inspect the motors for any obstruction. With the radio off, carefully clear any obstruction.  With the cover open, radio on, visually check if the motor(s) are turning. If the motor(s) are turning but the track is not, the gearbox needs repair.	Call or email tech support for further assistance
Tug operating sluggish/ low power	Tug is being operated on LOW or MEDIUM Speed.	Switch speed setting on remote controller to HI speed. (Rabbit Icon)	HI speed mode enables the tug's full power. It is recommended to use the tug in HI speed mode when operating outside, in an open area. LOW and MEDIUM speed modes are helpful when operating in small quarters for precise positioning.



Remote Controller			
Symptom	Cause	Action	Detail
Remote controller is beeping	Battery is low	Charge remote controller or replace remote controller batteries	See owner's manual section "Replacing Transmitter Batteries" for details It is recommended to keep the tug and remote controller charging <b>when not in use</b>
Remote controller does not turn ON	Battery voltage is below operable voltage	Charge remote controller or replace remote controller batteries	See owner's manual section "Replacing Transmitter Batteries" for details It is recommended to keep the tug and remote controller charging <b>when not in use</b>
Remote controller indicates a full charge soon after it is plugged into the charger	Charger has failed	Replace remote controller charger	The remote controller LED on the left side of the controller, just above the charging port, will illuminate green to indicate it is charging. The green will turn OFF once it is fully charged.
Wheel Cradle			
Symptom	Cause	Action	Detail
Unable to release the cradle	Not enough pressure on the wheel cradle back gate	Apply pressure with the tug and remote controller onto the back gate to relieve pressure on the latch mechanism.	If pressure is applied to the loading end of the cradle, away from the latch mechanism, it will cause the latch to bind and not release.
	Servo is not plugged in	Turn off the remote controller and tug. Open the magnetic tug cover. The servo is located next to latch mechanism, follow the wire to the radio receiver, located on the PC Board, and verify it is connected to slot number 6 on the radio receiver. Ensure the connection is fully engaged	
	Servo failure	Visually inspect the servo located next to the latch mechanism. Press the release button on the remote control, if no sound or motion is coming from the servo, the servo needs to be replaced	
	Latch is bound	Visually inspect the latch mechanism. Press the release button on the remote controller. If the cam, located on the servo next to the latch mechanism, turns but the latch does not disengage, service or replace latch assembly.	

## 5. Warranty

### LIMITED WARRANTY

Your new AC Air Technology Tug is warranted to the original purchaser (only) for one full year from the date of purchase to be free from factory defects in material and workmanship. During this 12-month period, AC Air Technology will repair or replace, at our discretion, the defective component determined by AC Air Technology to be defective.

This warranty does not apply to damage or defect resulting from mis-use, improper application, commercial use, or attempted repair by “non-AC Air Technology” service staff. The warranty does not cover shipping or handling cost or any incidental or consequential damage. Batteries and tracks are not covered by warranty.

### DAMAGE LIMITS

AC Air Technology shall not be liable for any damage, indirect or consequential, loss of profits or commercial or production loss, or other special loss or damage in any way connected with this product regardless whether such claim is based on warranty, in contract, negligence, or strict liability. In no event shall the liability of AC Air Technology exceed the individual price of the product on which liability is asserted. AC Air Technology has no control of the set up, application, use, modification, or misuse of this product, thus no liability shall be assumed or accepted for any resulting damage or injury. By the first act of use, set up or assembly, the user in using the product accepts all resulting liability. Failure to operate this product in a safe and responsible manner can result in damage or injury, both to the user as well as to others, the product, or property. This product is not a toy and is NOT intended to be used by children without adult supervision. It is essential to read the entire manual and warranty/liability information prior to first use/application/installation of this product to operate correctly and avoid damage/injury,

In cases where the purchaser or user are not prepared to accept liability associated with the use of this product, the user or purchaser is advised to return the unused product immediately in unused condition to the place of purchase.

### RETURN PROCEDURE

When sending equipment in for requested warranty service, please include a note describing the problems/concerns with the equipment. You must include your name, address, telephone number and email for prompt service. To request warranty service, a copy of your original sales receipt must be included. Warranty is approved and performed at the discretion of AC Air Technology service department. You are required to pay all postage, shipping and insurance charges.

### RETURN POLICY

Products can be returned within 10 days of delivery for a full refund if the product is in new condition and shipped with all the original packing and accessories. Any shipping cost associated with product delivery and/or return will not be refunded. A return authorization must be requested from AC Air Technology before any products can be returned.