

Instruction Manual

95490 Rev. K

MODEL: T1X3 Aircraft Tug



World's First Portable, Remote-Control Aircraft Tugs



World's First Portable Aircraft Tug

(855) TUGS ACAIR
(884-7222)

Table of Contents

1. Components	3
1-1 Components in the Box	3
1-2 Tug Components	4
1-3 Remote Control Components	5
1-4 Charger Components	6
1-5 Spare Parts	7
1-6 Track Tools	8
1-7 On-Board Parts Box	10
2. Start-Up Guide	11
2-1 Remote Control Operation	11
2-2 Operating the Tug	12
2-3 Adjusting the Wheel Cradle (Pre-Load Setup)	14
<i>Configuration A: For 16.25" Maximum Outside Tire Diameter</i>	<i>14</i>
<i>Configuration B: For 14.50" Maximum Outside Tire Diameter</i>	<i>15</i>
<i>Configuration C: For 8.25" Maximum Outside Tire Diameter</i>	<i>17</i>
2-4 Adjusting the Tire Guide Spacers	19
2-5 Loading the Aircraft Wheel	21
2-6 Unloading the Aircraft Wheel	24
2-7 Adjusting Track Tension	27
2-8 Charging the Tug	29
2-9 Charging the Remote Control	30
2-10 Replacing Remote Control Batteries	31
3. Troubleshooting	33
4. Warranty	37

1. Components

1-1 Components in the Box

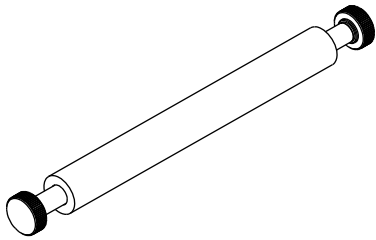

Accessory Cradle Roller
This is installed on the cradle in Configuration B. See page 14

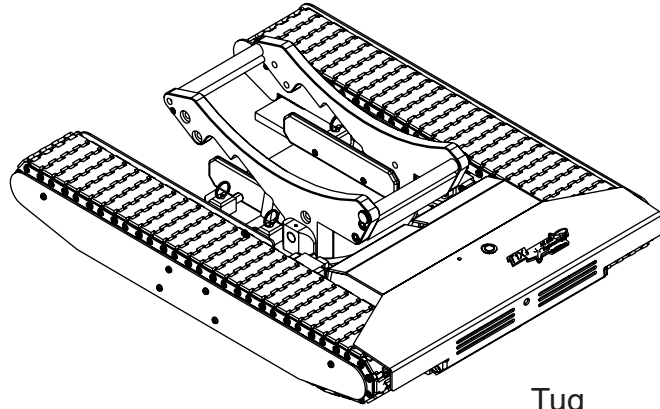

Tug

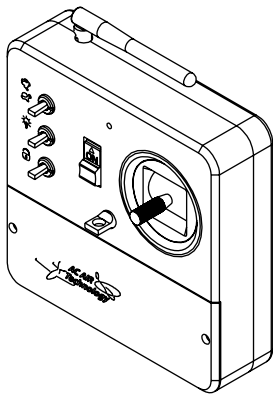

Radio Transmitter

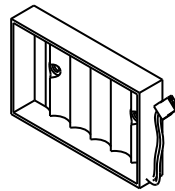

Battery Tray

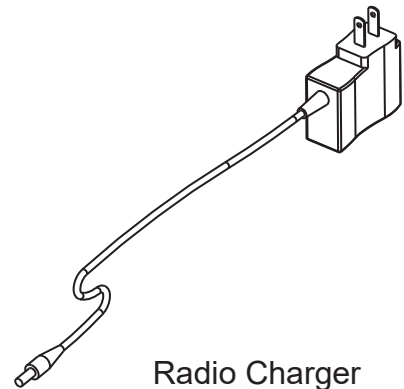

Radio Charger

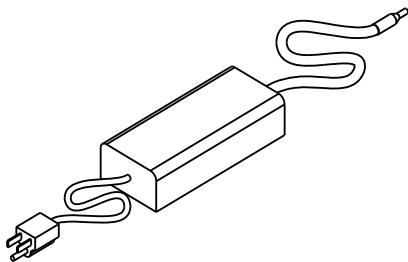

Tug Charger

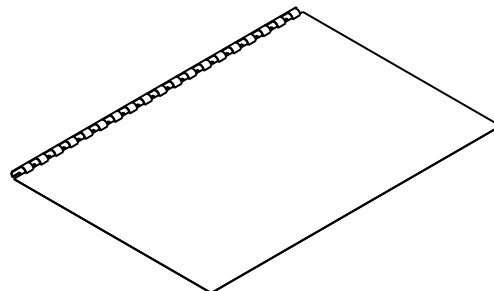

Owners Manual

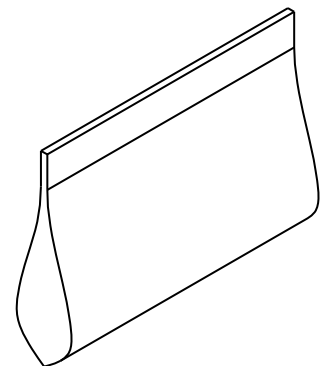

Spare Parts Bag

1. Components

1-2 Tug Components

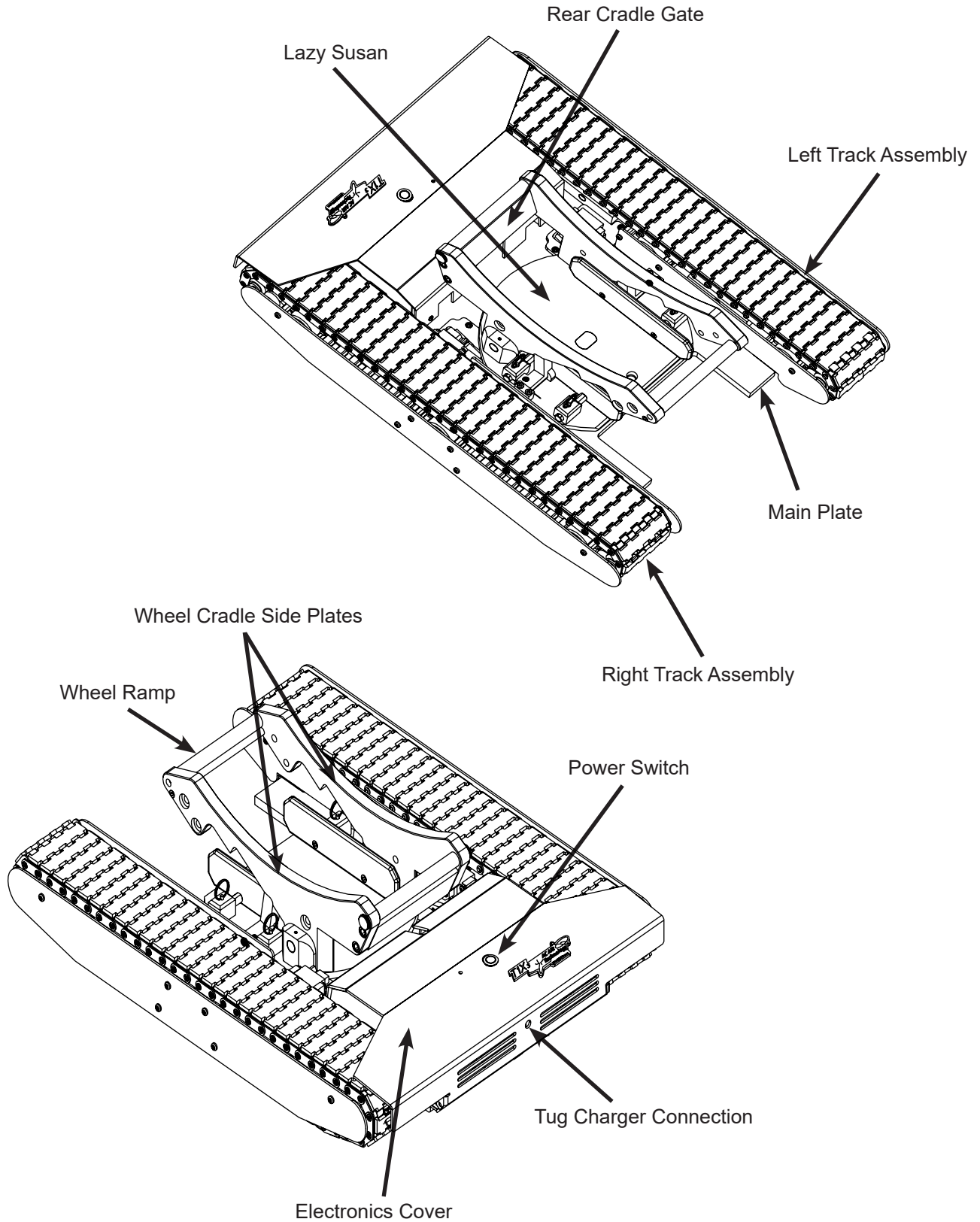

1. Components

1-3 Remote Control Components

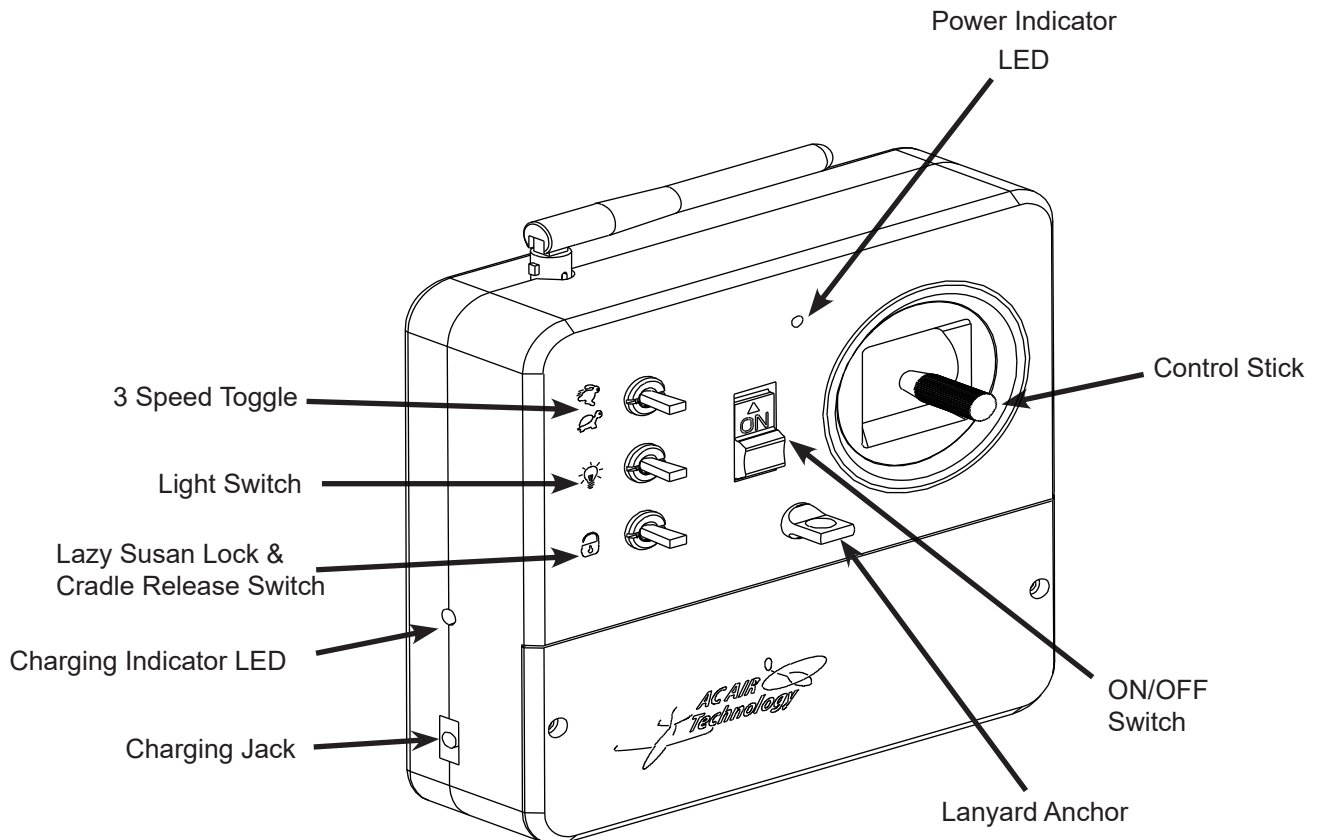

Warning: The control stick on the remote controller is very sensitive and will cause the tug to move if it is moved accidentally. Turn OFF the remote controller when not in use.

Note: If the remote controller is not used for a few minutes it will start beeping as a indicator that it is still in the ON position. This is not an indicator of a low battery.

1. Components

1-4 Charger Components

Tug Charger

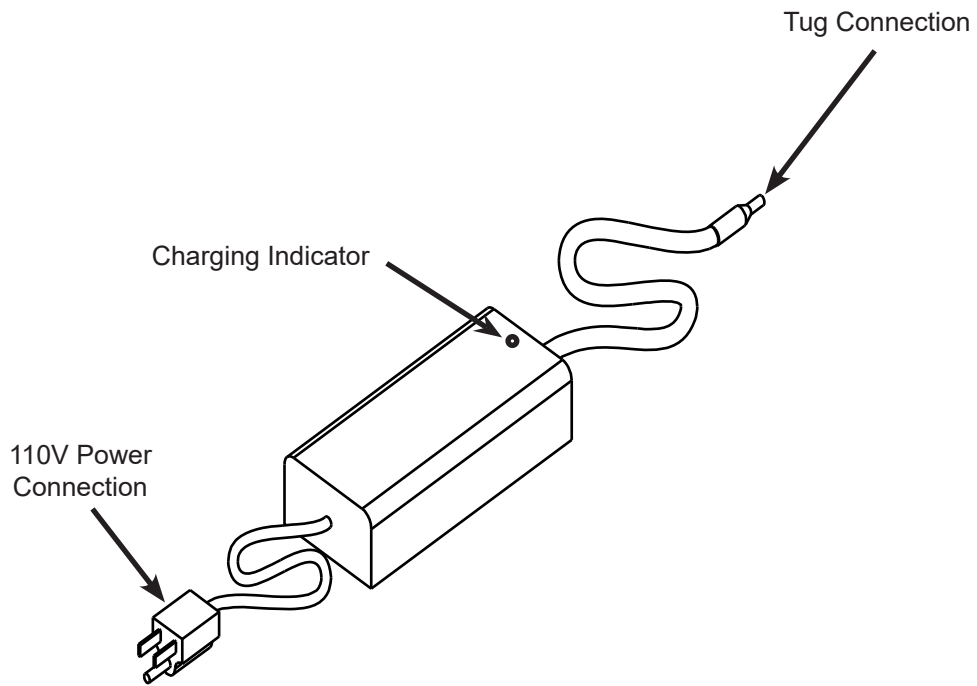

Remote Control Charger

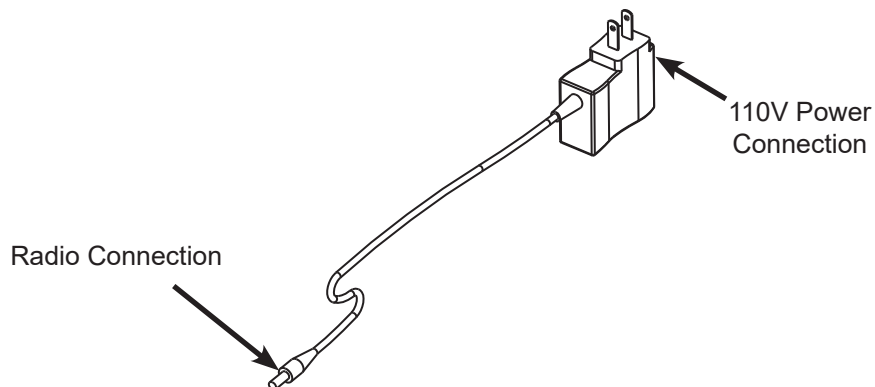

1. Components

1-5 Spare Parts

Spare Track Parts

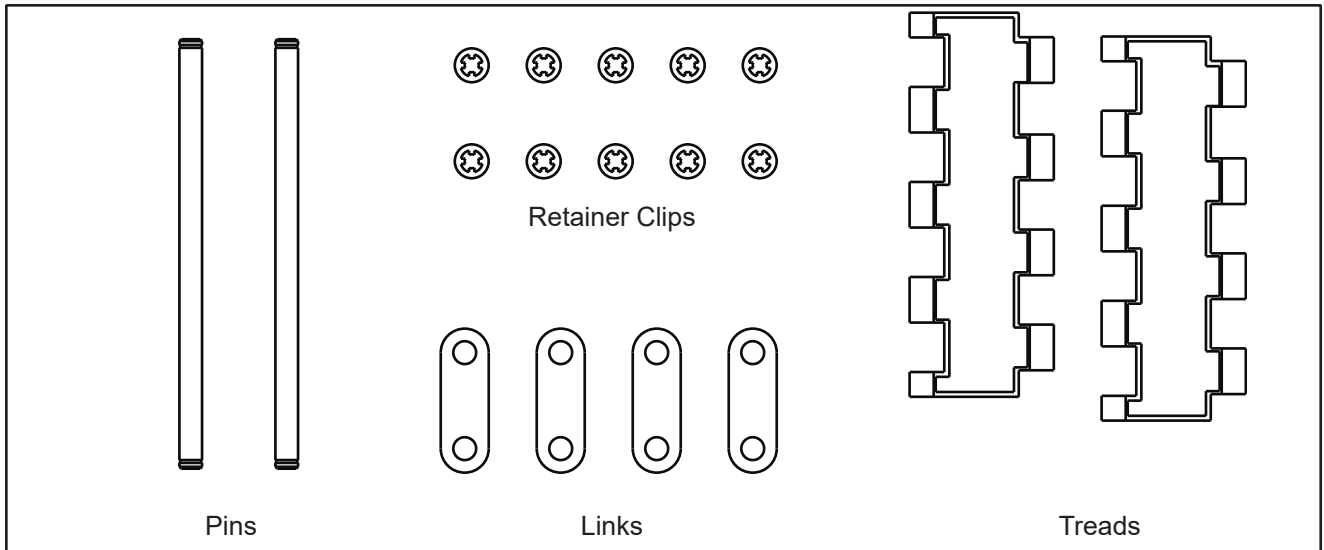

Track Install Tools

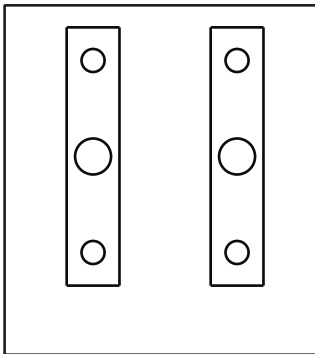

Fuses

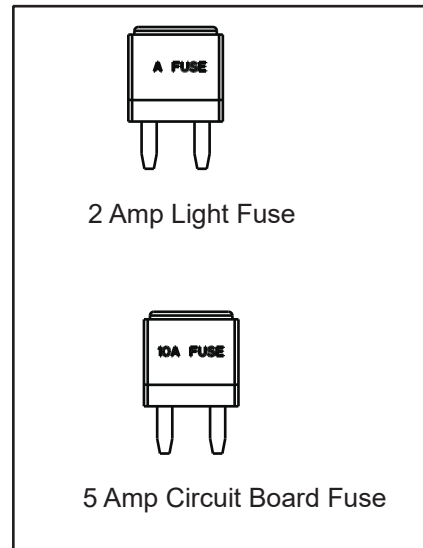

1. Components

1-6 Track Tools

The track tools are used to assist in the installation of new tracks.

This section is intended to show how the tools are used only. A detailed instruction guide is provided when purchasing new tracks. Refer to that instruction guide when installing new tracks.

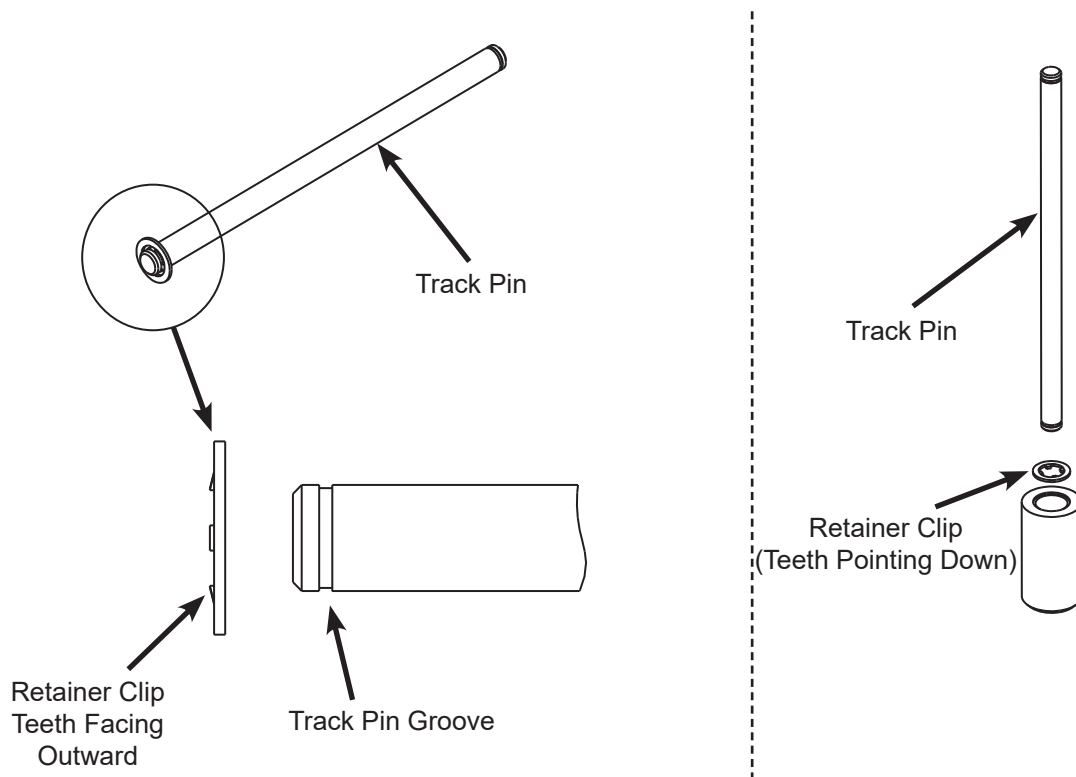

When the retainer clip is properly installed into the track pin groove is should rotate freely inside of the groove.

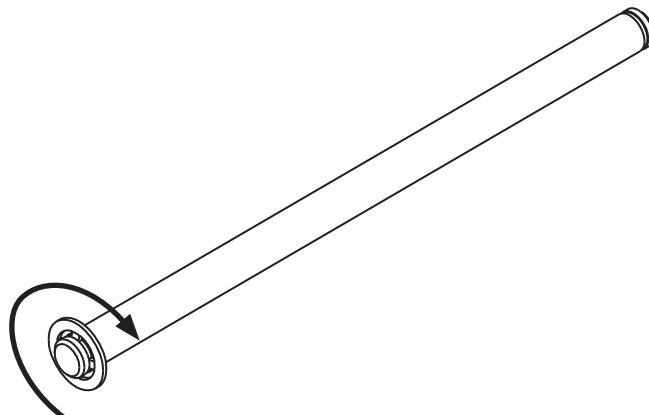

The Track Pin Tools are used to assist in the installation of new tracks when the they are too tight making it difficult to align the pin holes.

Insert the track pin tools on the inside and outside adjacent pins to the missing pin hole. You will need to hold these in place by hand.

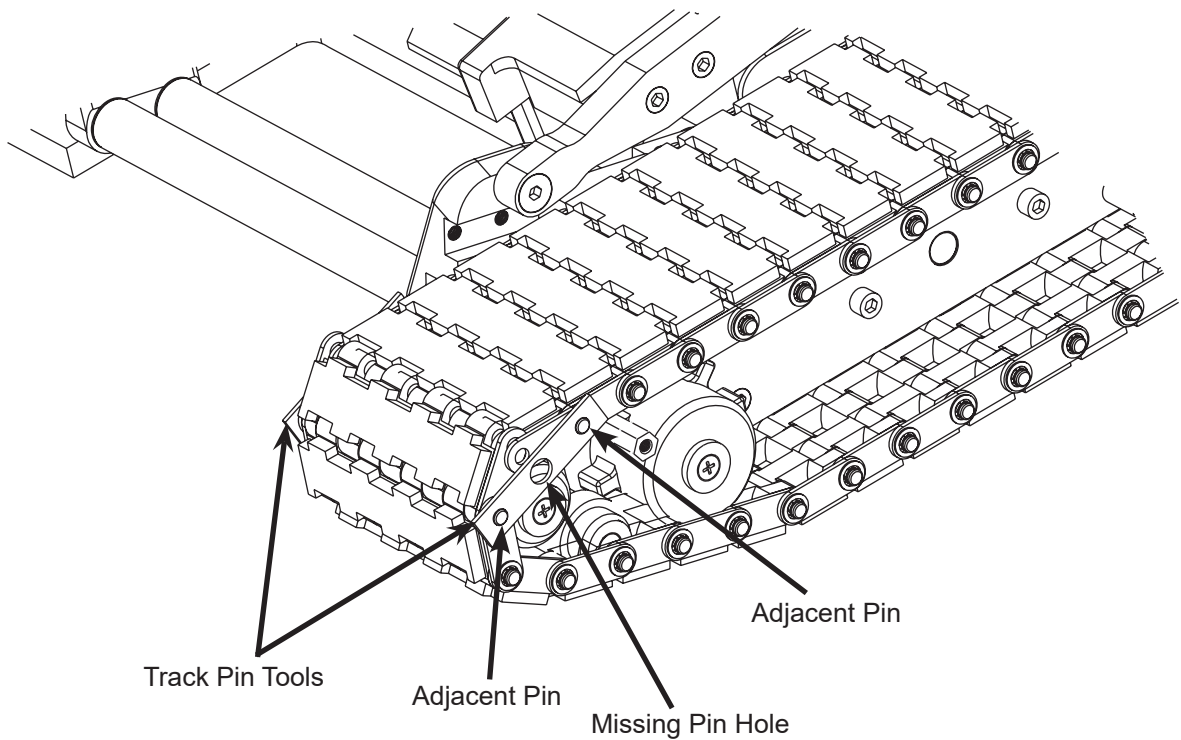

1. Components

1-7 On-Board Parts Box

The On-Board Parts Box contains spare track links, clips, and tools to quickly replace or repair tracks. These components are located on-board the tug, underneath the electronics cover.

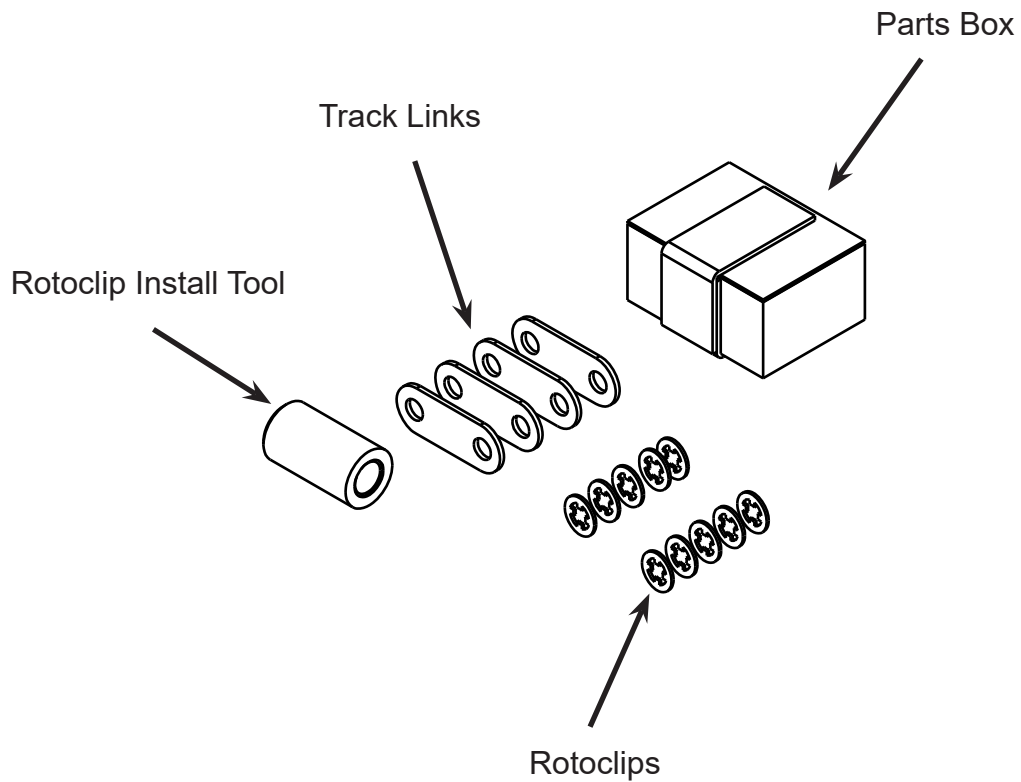

2. Start-Up Guide

2-1 Remote Control Operation

1. Switch the remote control ON. The power indicator light turns on and the remote control beeps once. If this does not happen, check the remote control battery connection for proper installation. When the battery level is low, the remote control will begin to beep repeatedly, signaling to replace or recharge the batteries.
2. To drive the tug, move the control stick in the desired direction.
3. The Lazy Susan Lock & Cradle Release Switch is a 3 position switch. The Unlock and Lock positions are used to lock the lazy susan rotation. The Release position is to release the tire from the cradle while unloading.

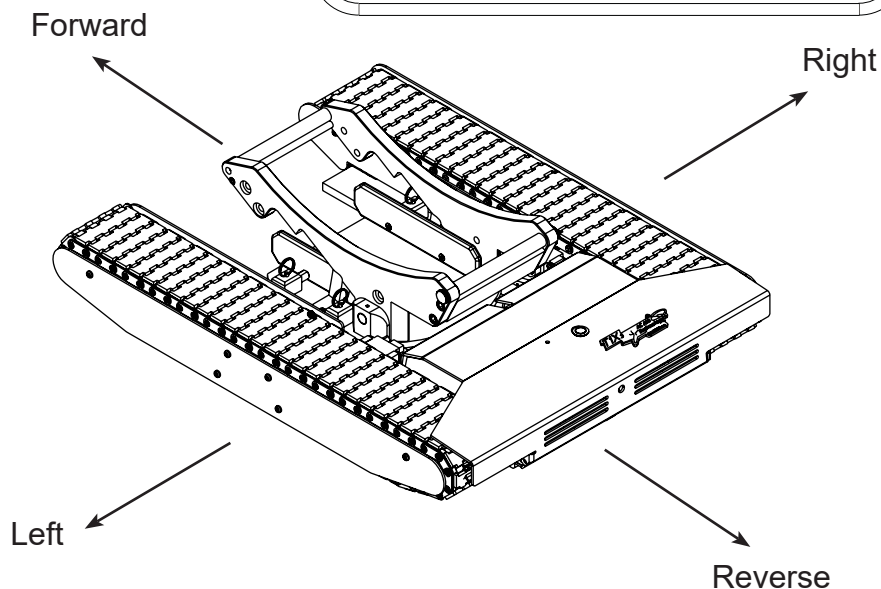
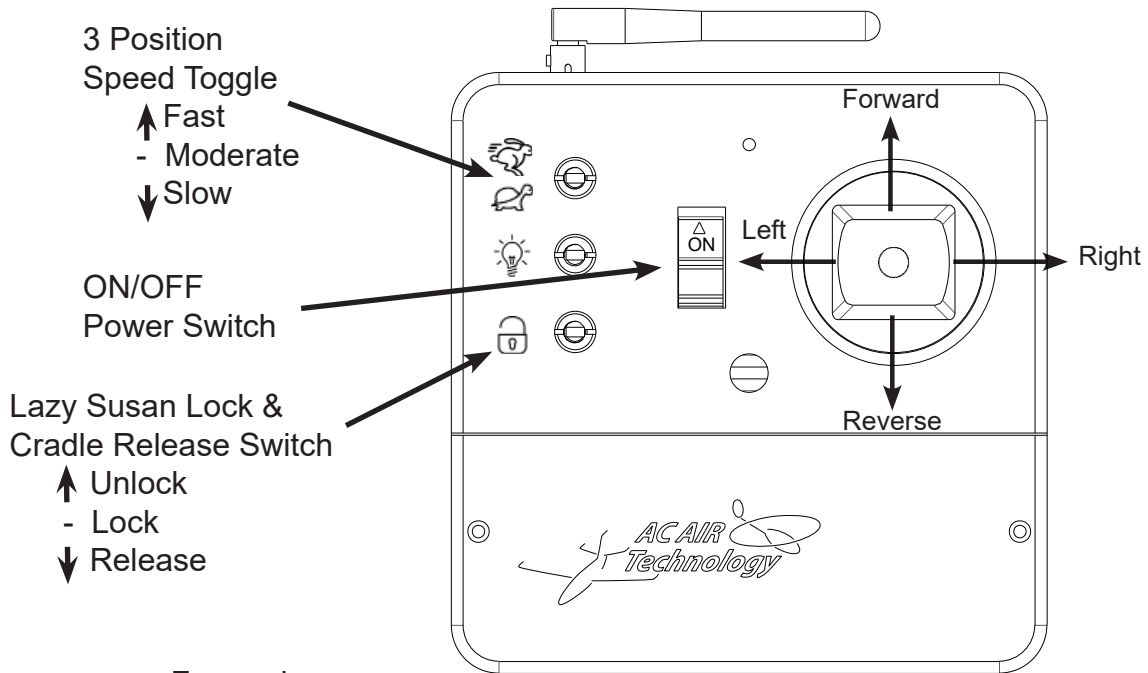

2. Start-Up Guide

2-2 Operating the Tug

1. Before turning on the tug, make sure the tracks and bottom of the tug are free from obstruction.
2. Turn the tug on using the ON/OFF switch. There will be a short series of beeps and then the ON/OFF switch will illuminate red to show the tug is on. The ON/OFF switch light will be on solid when the battery is fully charged. When the tug battery is low the ON/OFF switch light will blink and there will also be a beeping sound.

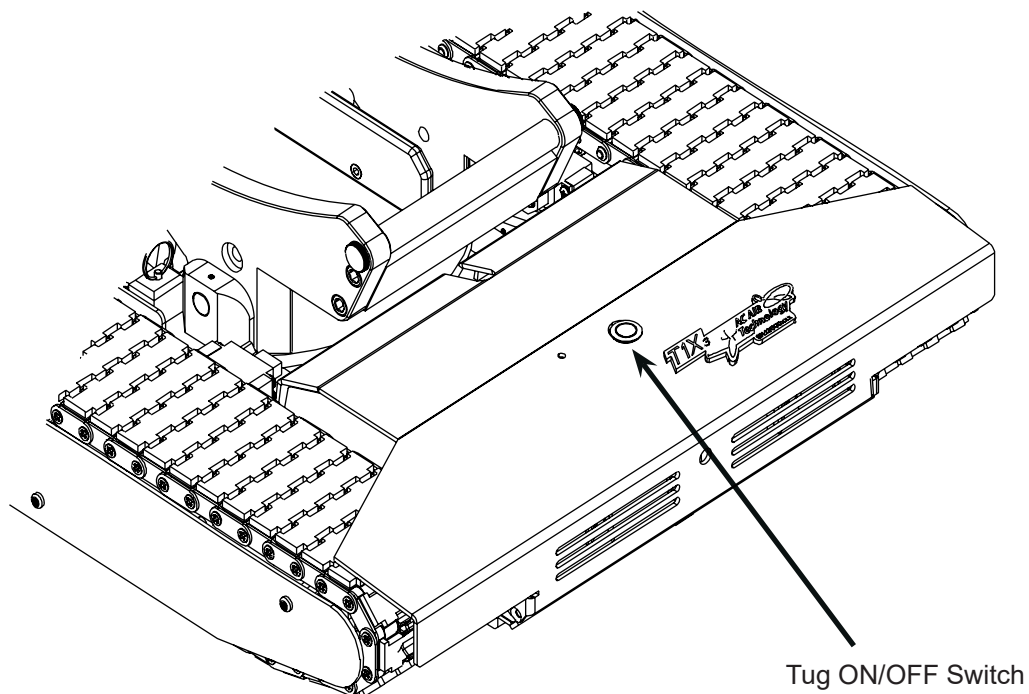

3. Turn on the power switch on the radio controller. The power indicator LED will illuminate green/blue in color. **It is recommended you practice maneuvering the tug prior to loading the plane.**
4. It is recommended to use the radio in fast speed mode. Moderate and Slow speed mode should be used when maneuvering in tight quarters as it reduces the tugs power output.
5. When towing your airplane **ALWAYS** be cautious of the steering angle limitations of your aircraft. Do not over steer your aircraft with the tug. This can cause damage to your gear.

6. After lifting the tug off of the ground for any reason or taking it in and out of your aircraft, you must check the sprockets for proper seating along the tracks. If the sprocket is not properly seated it could result in damage to the track.

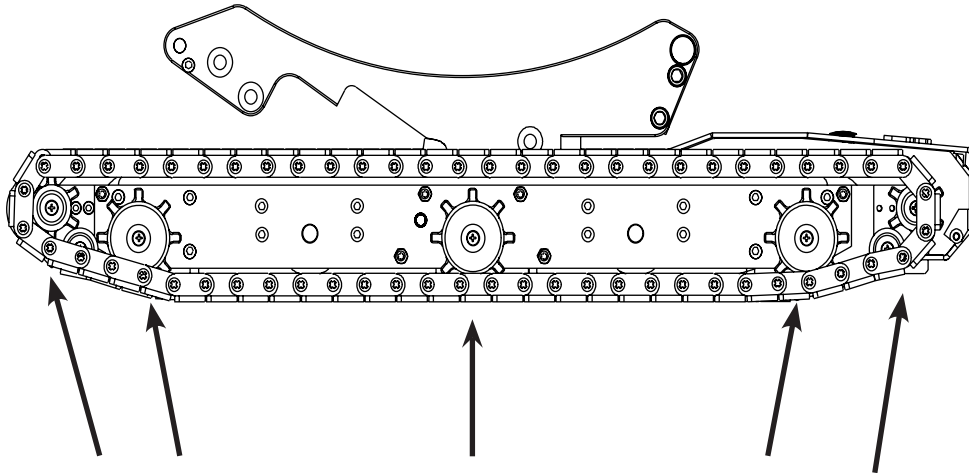

Check sprockets for proper seating and alignment.

7. Visually check tracks for wear on the treads and wear on the inner plastic surfaces. Also inspect for damaged or missing retainer clips as a result of driving over small rocks. Damaged treads should be replaced before operating the tug.

2. Start-Up Guide

2-3 Adjusting the Wheel Cradle (Pre-Load Setup)

Note: You do not want the tire to be tight inside the wheel cradle. There should be space for tire size variations. After configuring the wheel cradle, drive the tug under the tire to verify the wheel cradle is setup correctly and to ensure the cradle lock is fully engaged.

1. The wheel cradle can be adjusted to 3 different positions depending on your aircraft's tire diameter. The three configurations are as follows:

Configuration A: For 16.25" Maximum Outside Tire Diameter

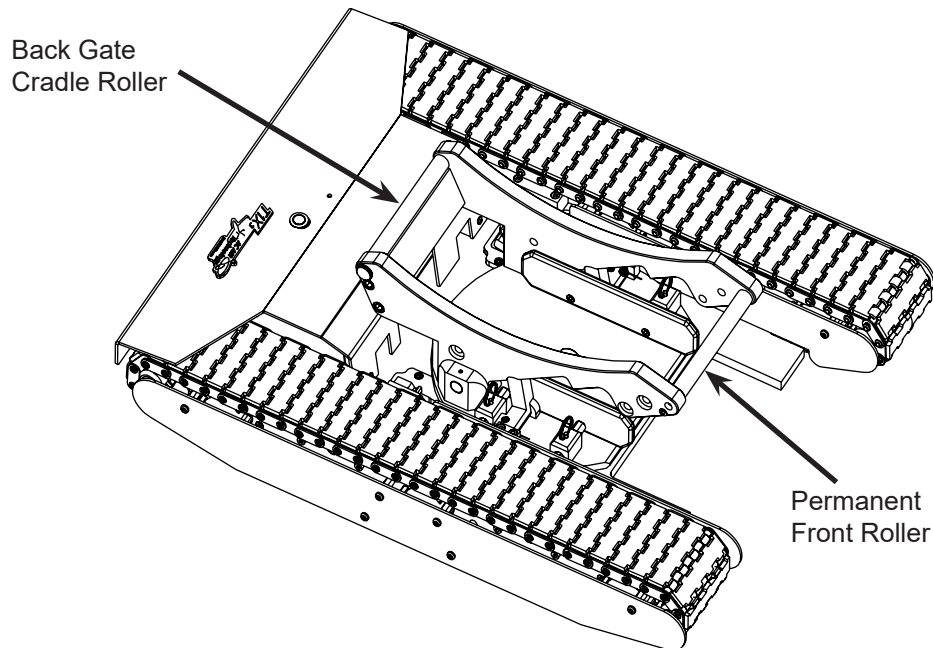

- 1A. The wheel cradle Back Gate Roller should be in the position shown above. No accessory required.

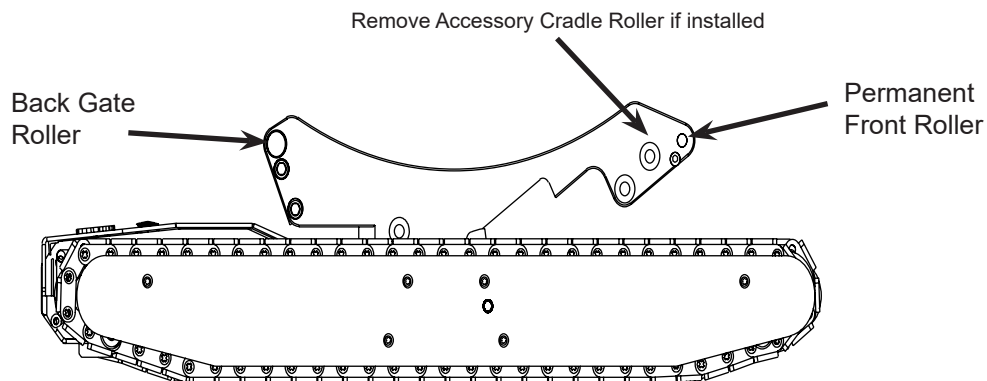

Configuration B: For 14.50" Maximum Outside Tire Diameter

1B. For Configuration B the supplied Accessory Cradle Roller will be needed.

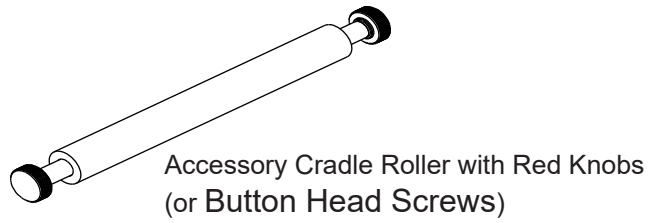

2B. Disassembly the Accessory Cradle Roller.

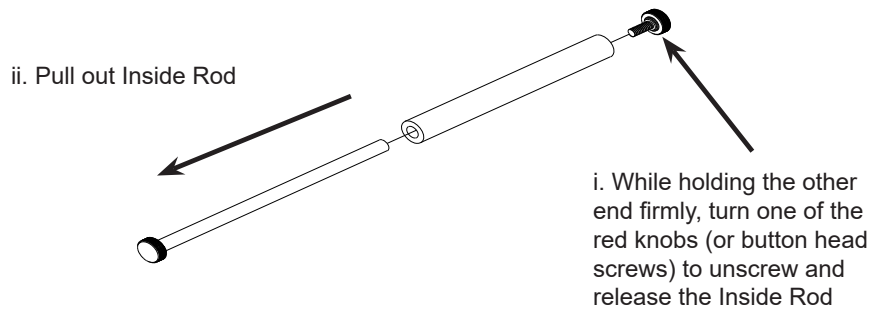

3B. The wheel cradle **Back Gate Roller** should be in the position shown below.

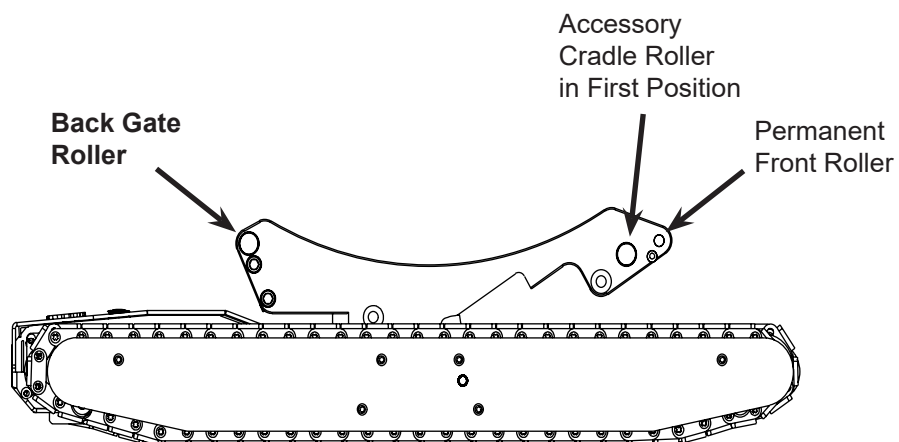

4B. Install the **Accessory Cradle Roller** into the wheel cradle's First Position (position shown is step 3B above) by holding the outside roller in between the wheel cradle and sliding the inside rod through one end of the wheel cradle and out the other. Secure the Accessory Cradle Roller with the red knob. Ensure both red knobs (or button head screws) are securely fastened.

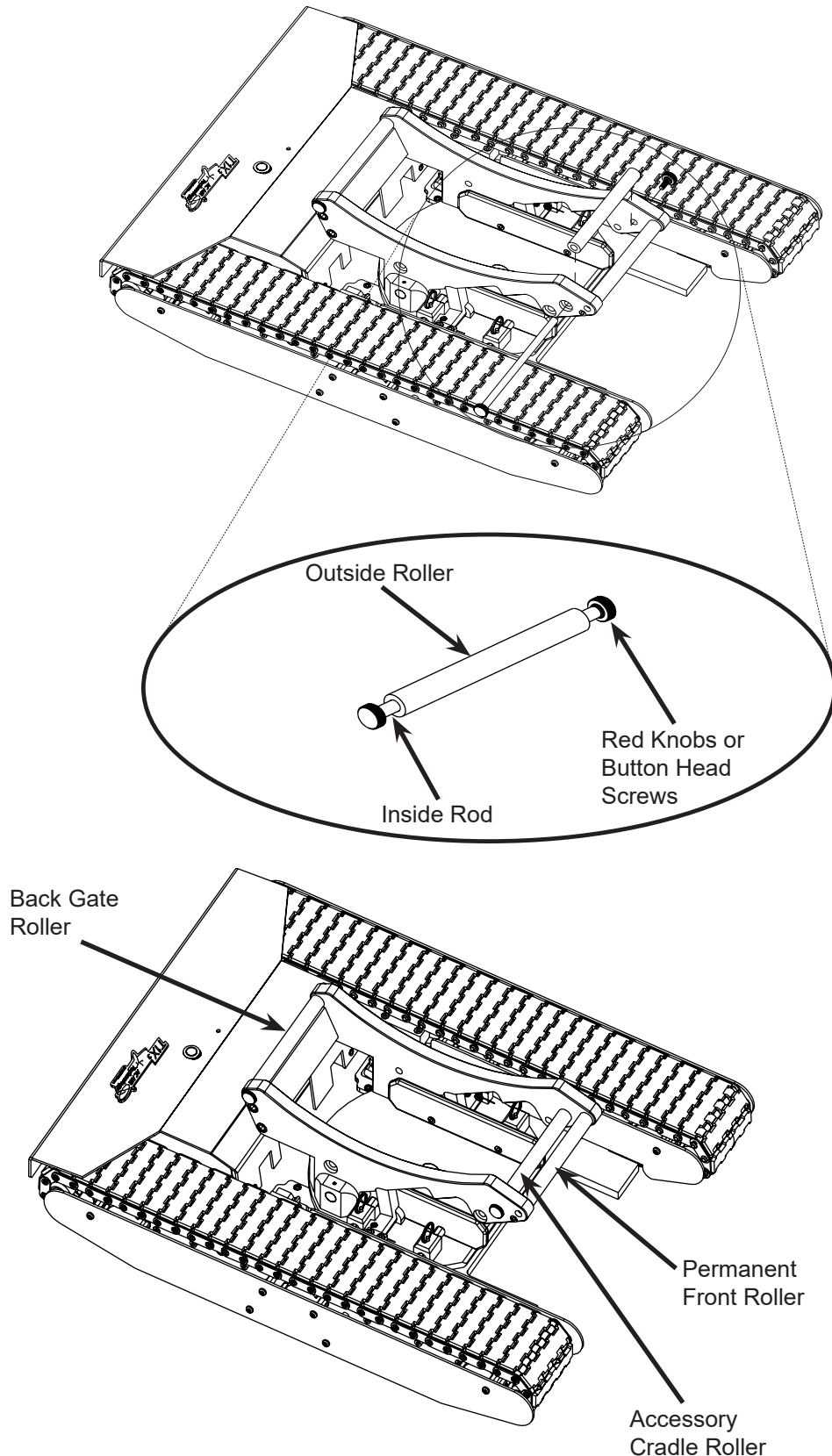

Configuration C: For 8.25" Maximum Outside Tire Diameter

1C. For Configuration C the supplied Accessory Cradle Roller will be needed.

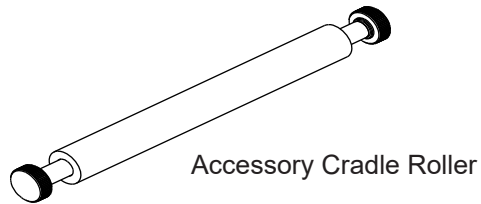

2C. Disassembly the Accessory Cradle Roller.

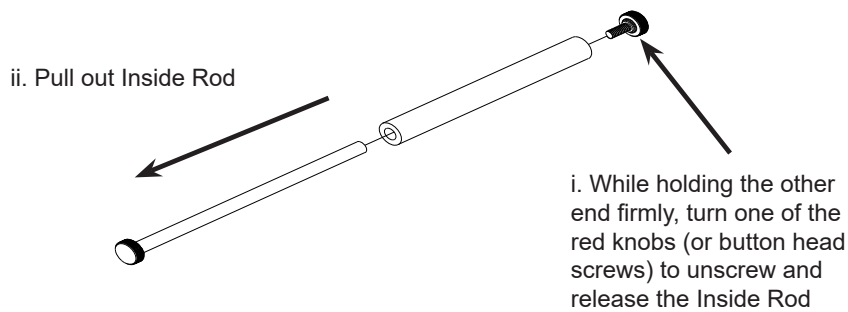

3C. The wheel cradle **Back Gate Roller** should be in the position shown below.

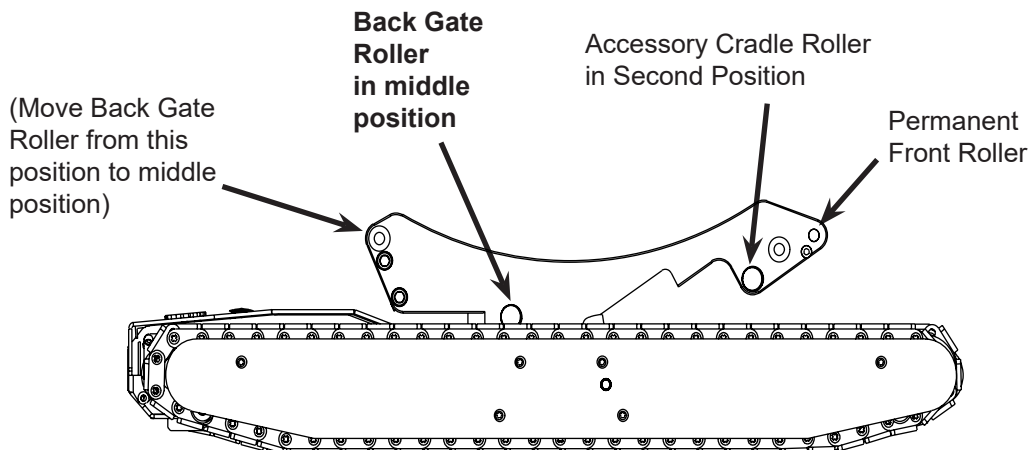

4C. Install the **Accessory Cradle Roller** into the wheel cradle's Second Position (position shown is step 3C above) by holding the outside roller in between the wheel cradle and sliding the inside rod through one end of the wheel cradle and out the other. Secure the Accessory Cradle Roller with the red knob. Ensure both red knobs (or button head screws) are securely fastened.

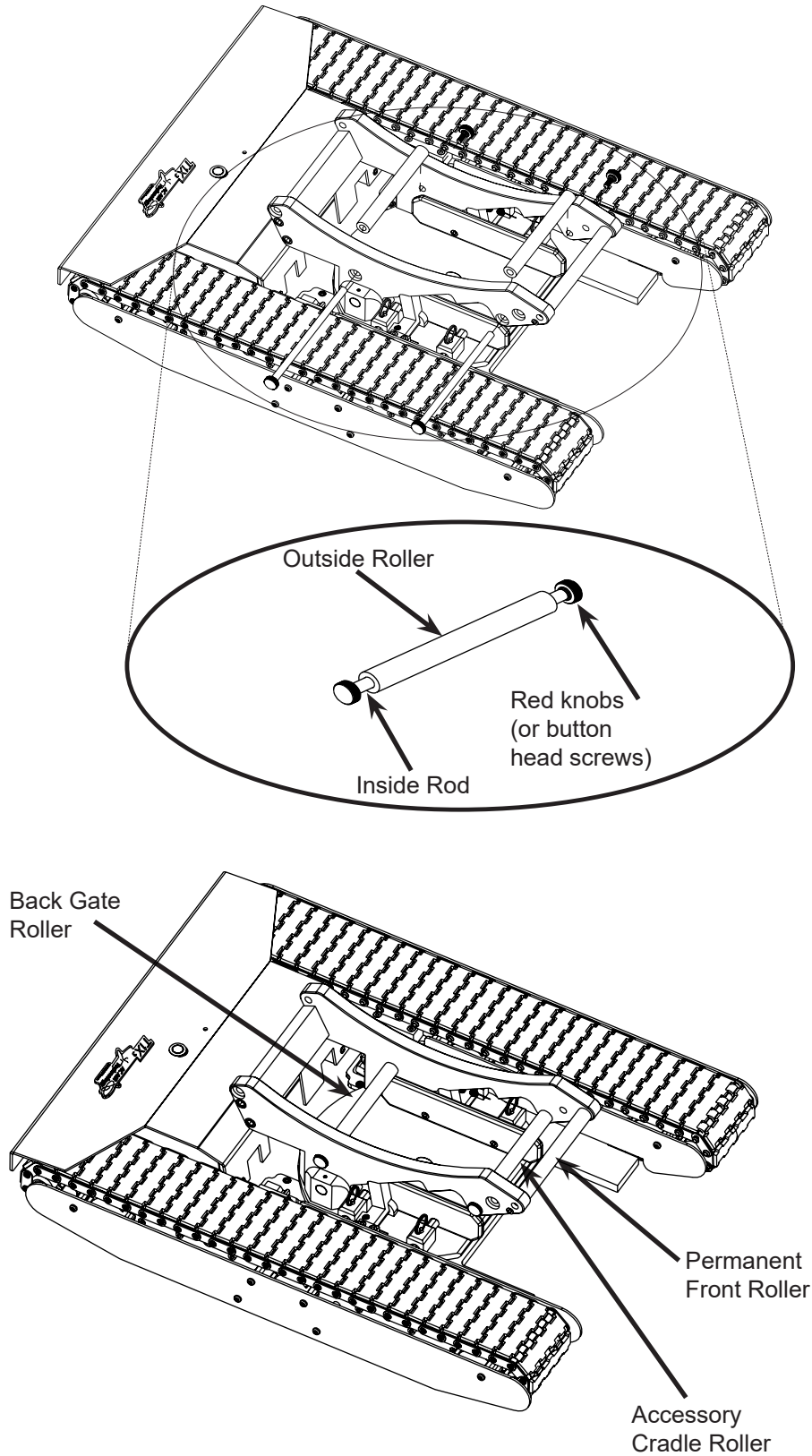

2. Start-Up Guide

2-4 Adjusting the Tire Guide Spacers

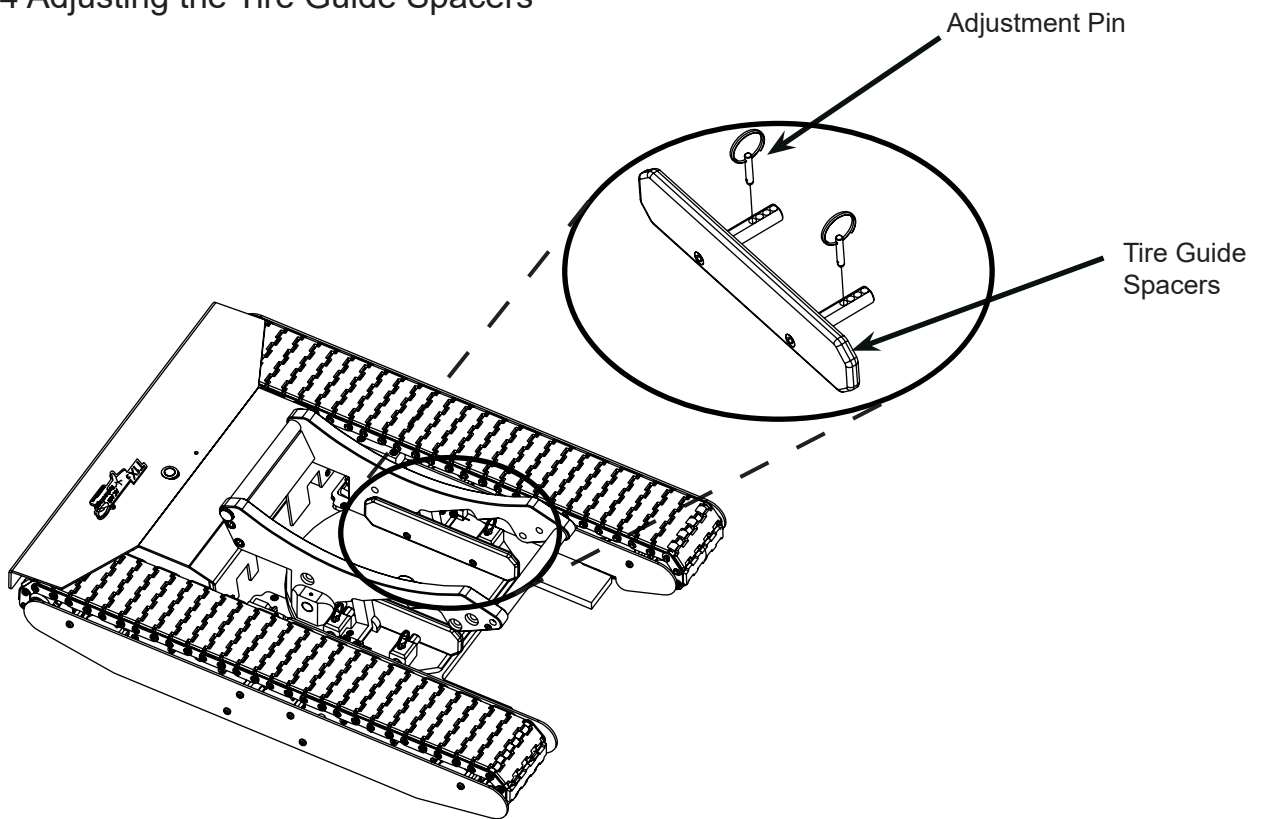

1. If the tire guide spacers are in the widest position and your tire does not fit or it is too close of a fit remove the tire guide spacers and adjustment pins.

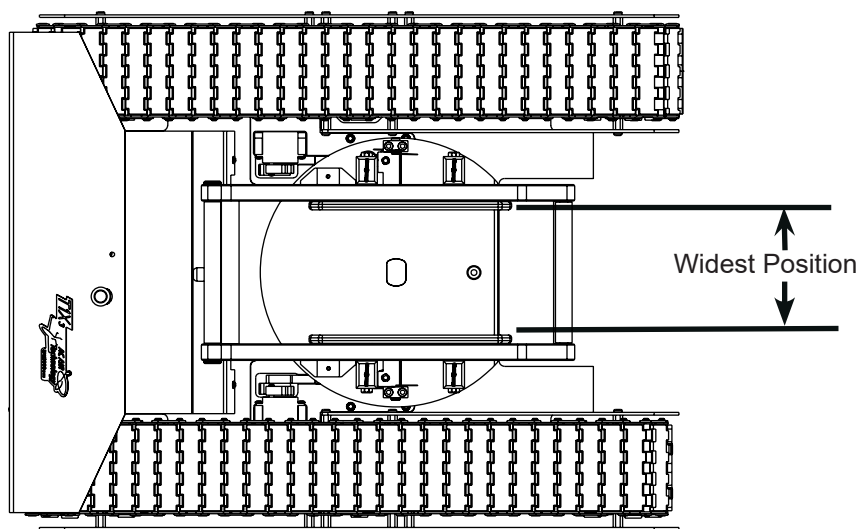

2. Adjust the tire guide spacers by removing the adjustment pins and sliding the spacers towards each other. Ideally the tire guide spacers should be moved the same distance on each side to keep your tire centered in the cradle. The distance between the dovetail spacers should equal the width of your tire plus one inch maximum.

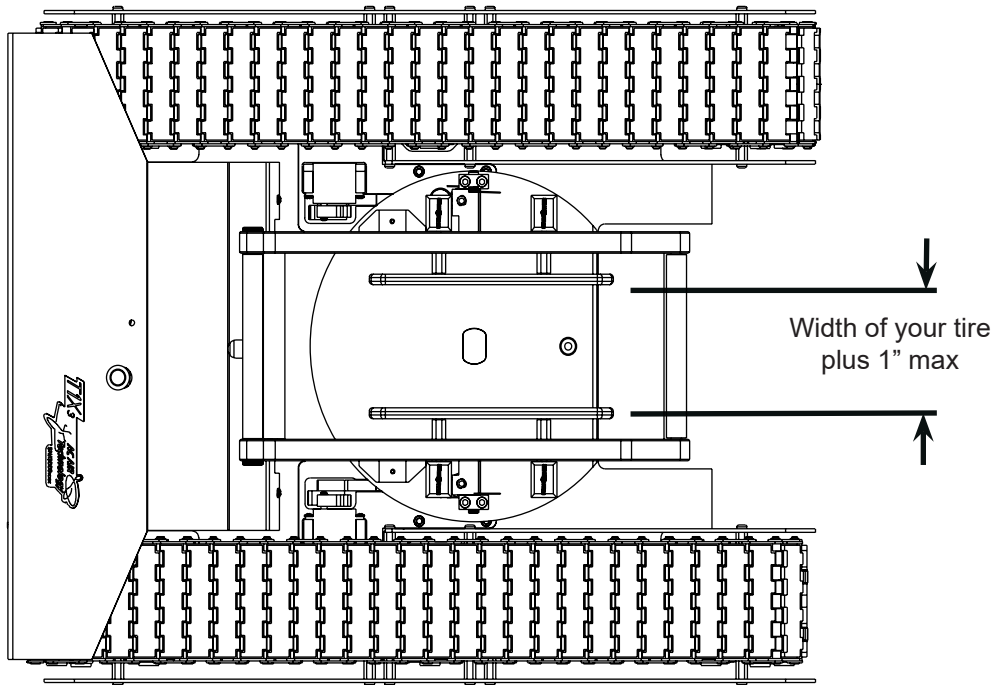

3. Align the adjustment pins to the nearest holes. Insert the adjustment to secure the tire guide spacers.

2. Start-Up Guide

2-5 Loading the Aircraft Wheel

WARNING:

DO NOT SIT IN THE PLANE WHILE DRIVING THE TUG.

TO PREVENT GOING BEYOND YOUR STEERING LIMITS IT IS HIGHLY RECOMMENDED THAT YOU LOCK THE LAZY SUSAN FROM ROTATING WHILE GOING UP AND DOWN HILLS AND MOVING ALONG A STRAIGHT PATH. THE LAZY SUSAN FEATURE SHOULD ONLY BE USED ON FLAT GROUND AND WHEN MANEUVERING IN TIGHT QUARTERS.

1. Once the pre-load setup is complete turn ON the tug and remote controller. The wheel ramp needs to be in the down position before loading the aircraft wheel. If the wheel ramp is in the up position, toggle the latch release switch on the radio controller to the middle (lock) position. Rotate the lazy susan until it clicks into the locked position. Toggle and hold the latch release switch on the remote controller in the release (low) position then tap the back of the cradle. The wheel cradle should fall to the down position. CAUTION: There is a manual release for the wheel cradle on the cradle lock, take extra caution when releasing the cradle manually. The ramp release only occurs when the lazy susan is oriented as shown below. Once the wheel ramp is in the down position toggle the latch release switch to the middle position, locking the lazy susan from rotating.

WARNING:

DO NOT PUT ANY PART OF YOUR BODY IN THE MECHANISM WHILE RELEASING THE LATCH. SEVERE BODILY INJURY CAN OCCUR.

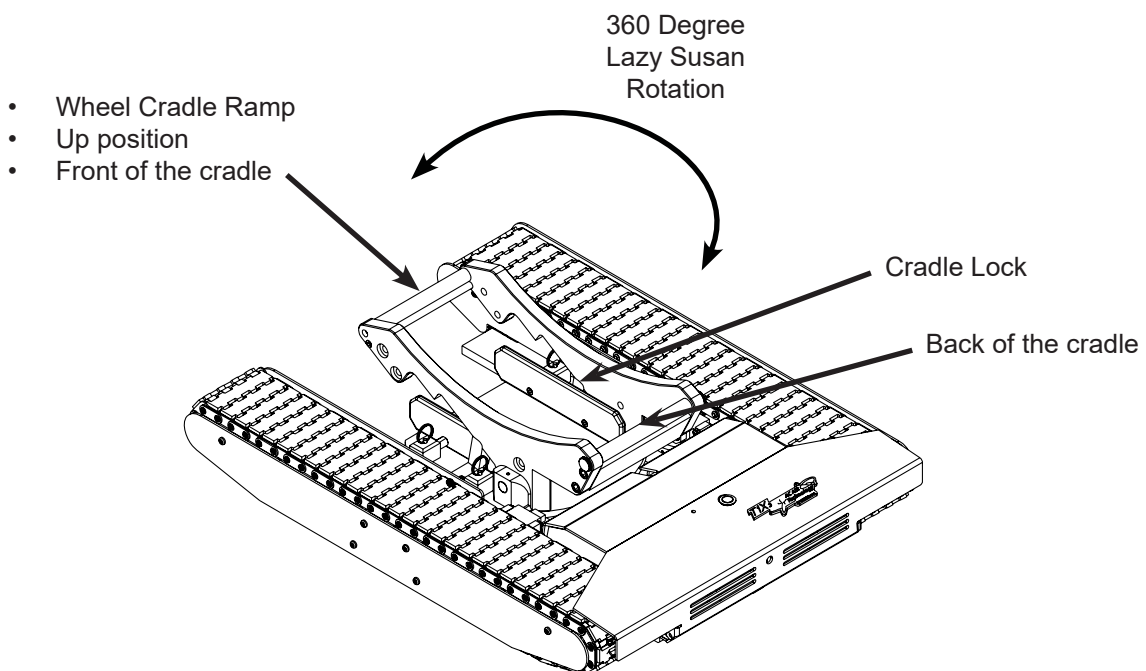

2. Drive the tug to line up the aircraft tire with the center of the wheel ramp.

It may be necessary to apply a little pressure with your foot to the top of the tug shroud to get the wheel started onto the tug.

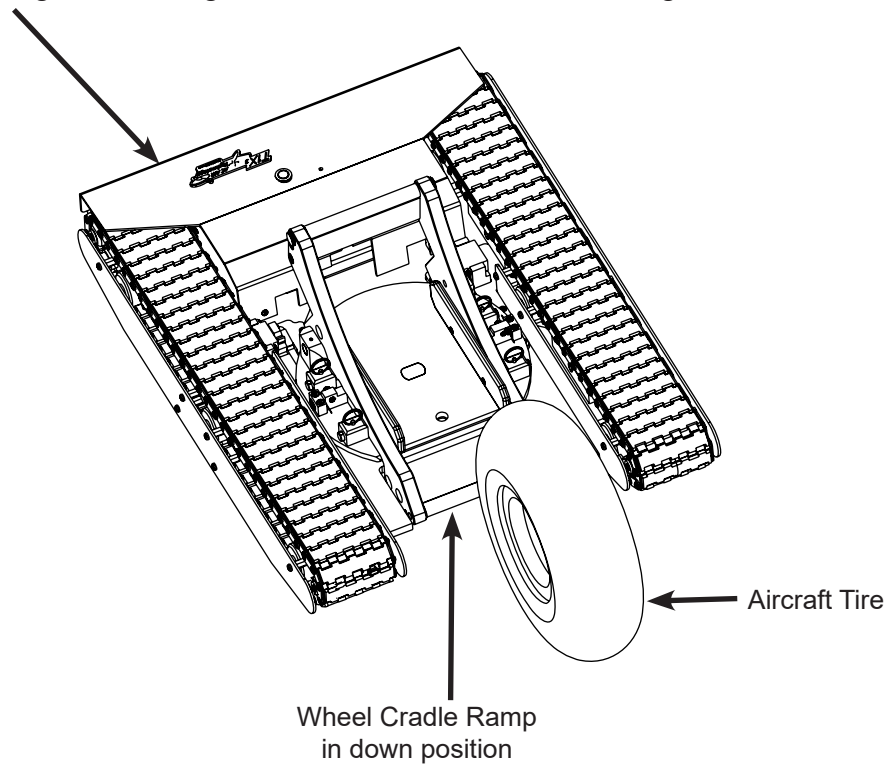

3. Drive the tug under the aircraft tire until the tire is positioned on top of the lazy susan. It may be necessary to chock the wheels to keep the plane from moving.

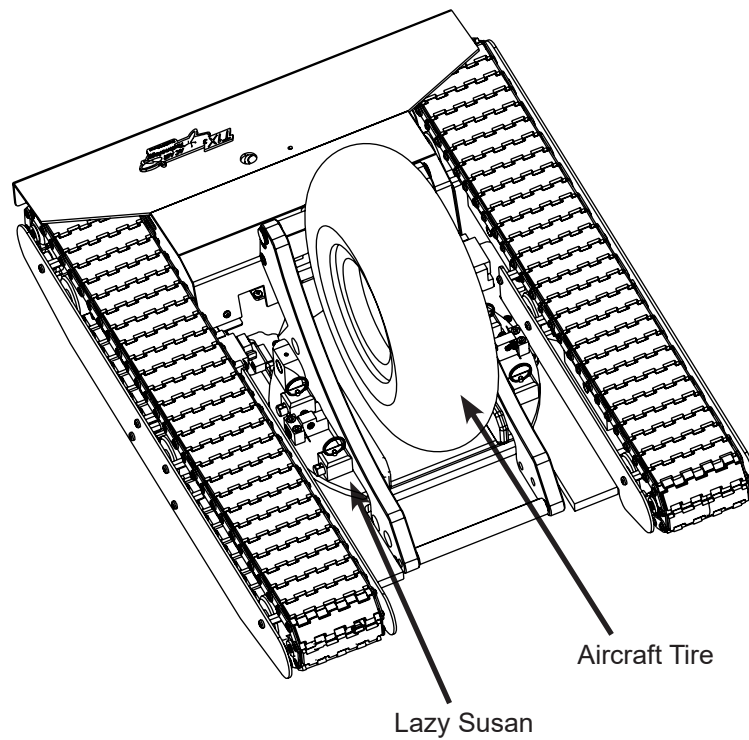

4. Continue driving the tug under the tire until the rear gate locks onto the latch and the wheel ramp is in the up position.

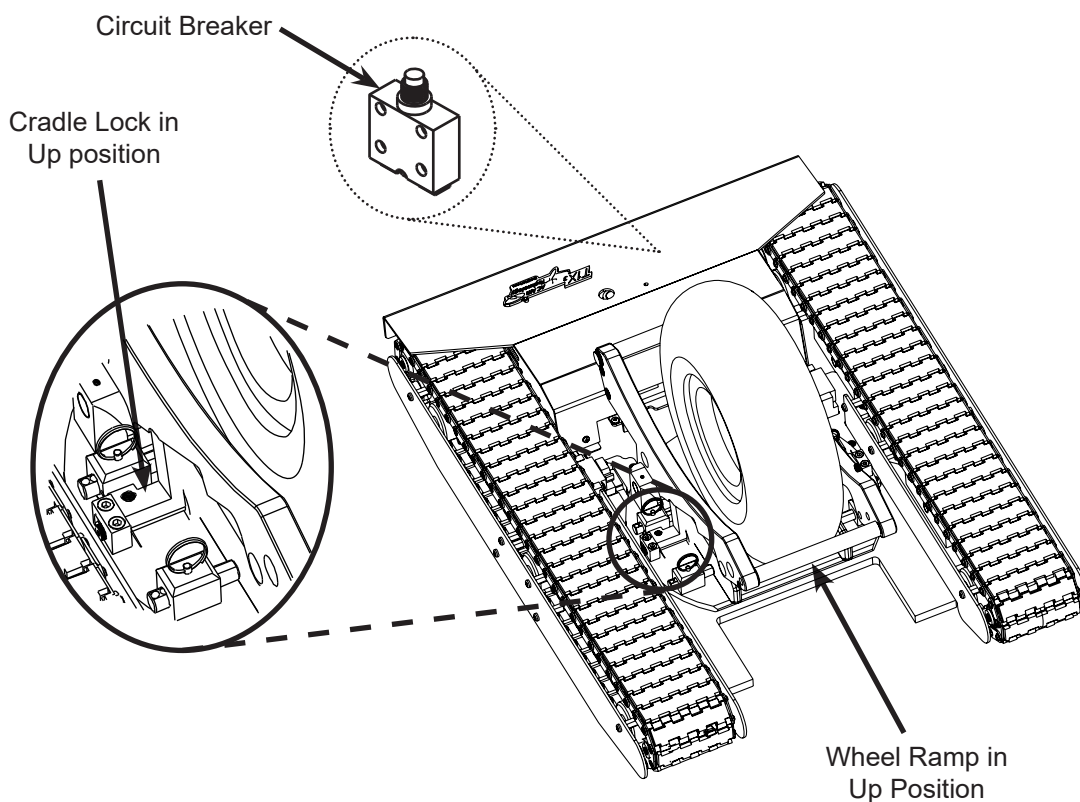

5. The Lazy Susan Lock switch on the radio can be moved to the unlocked position during operation to allow **360° of rotation**.
6. The circuit breaker reset buttons will trip if the tug is overloaded. To reset the circuit breakers open the access cover and locate the two white or black button on the circuit board. See image above. Press it down to reset the circuit breaker.

Critical Note:

If the circuit breaker button pop up after being reset, the tug is being overstressed and could cause damage to the circuit board. Address any mechanical issues such as a seized sprocket or missing track retainer clips or any driving conditions such as driving up a steep incline or towing above the tugs capacity that could be causing the tug to overstress. If the issue persists call or e-mail AC Air Technology tech support for further assistance.

2. Start-Up Guide

2-6 Unloading the Aircraft Wheel

Note: It is recommended to chock the wheels to keep the plane from moving

1. Toggle the Lazy Susan Lock Switch in the middle (Lock) position.
2. Rotate the tug under the tire until the wheel cradle is at 0 degrees. A click will be heard when it reaches 0 degrees.

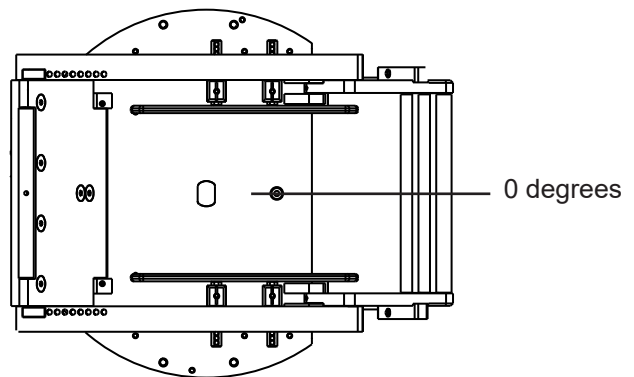
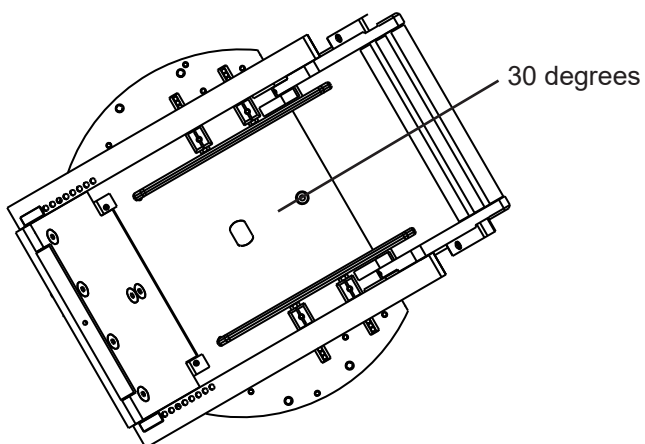
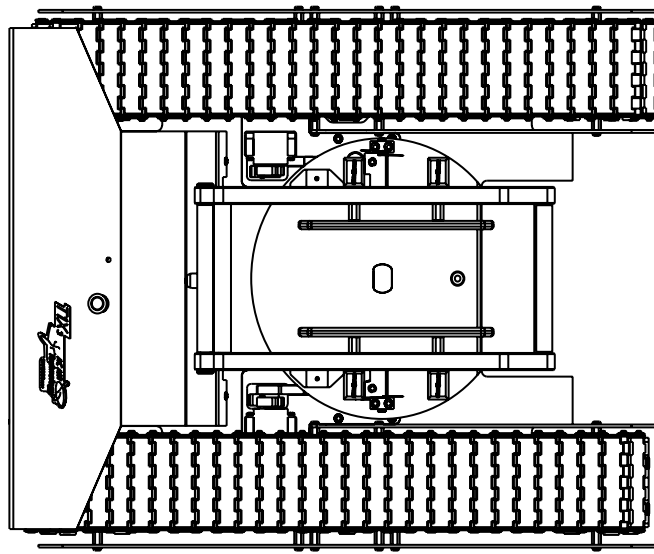

3. Toggle and hold the Wheel Cradle Switch in the Release position (down). Then with the joystick, move the tug against the tire so that there is slight pressure against the tire and rear gate. This will release the tension on the latch mechanism. Maintain this slight pressure.

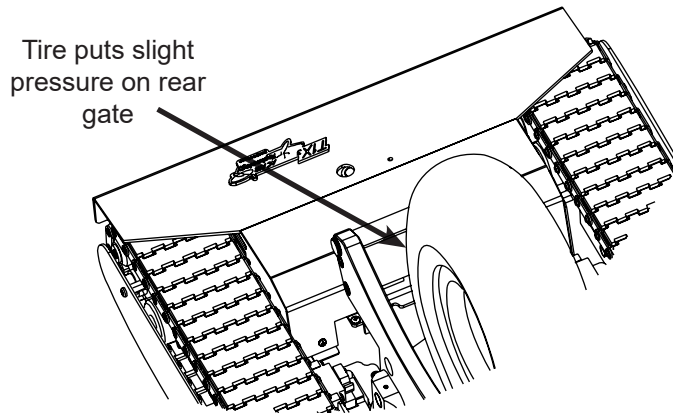

4. Back the tug out from underneath the tire. The wheel cradle should pivot down, releasing the tire. If the wheel cradle does not pivot down, slightly move the tug from left to right to re-center the wheel cradle lock, you will hear a click when the cradle lock is engaged.

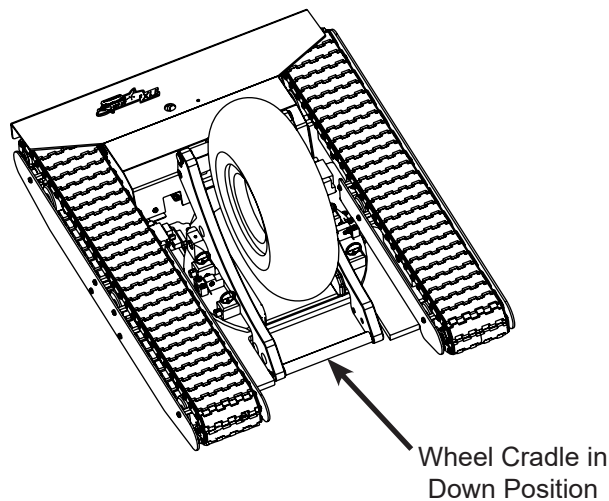

5. Continue driving the tug away from the tire until the tire is completely off of the tug. Release the Wheel Cradle Switch once the tire is completely off of the tug.

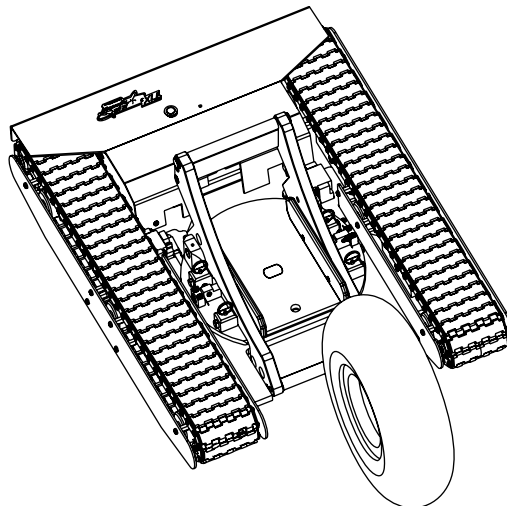

2. Start-Up Guide

2-7 Adjusting Track Tension

Track tension may need to be adjusted after several hours of use. Follow the instructions below for each track.

1. Remove 6 cover screws to remove the track plastic cover.

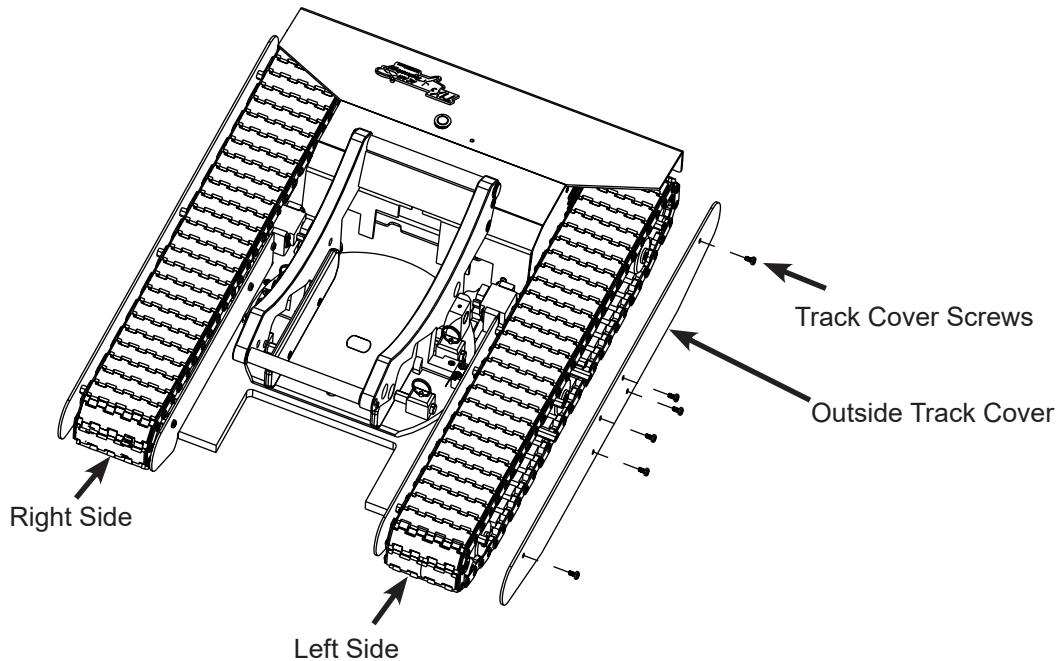

2. Loosen three front rail end retainer screws with a 3/16" hex drive. It may be necessary to rotate the large sprocket to get access to one of the retainer screws.

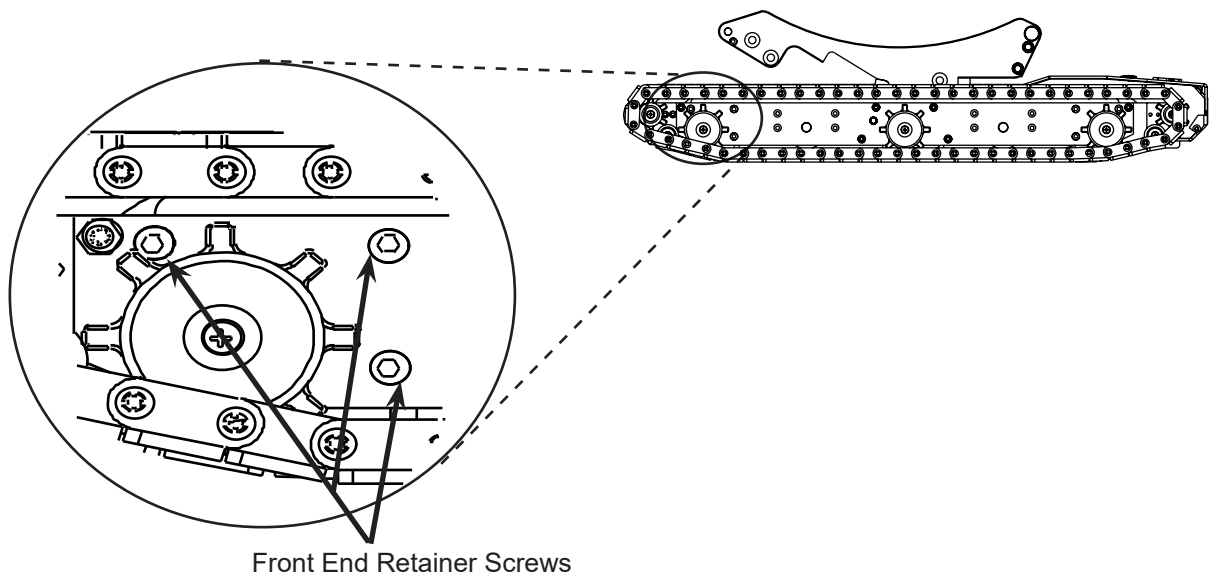

3. Push the rail end forward using a small pry bar to tighten up the track. There should be a 1/2" of play at the center of the track. Do not over tighten the tracks.

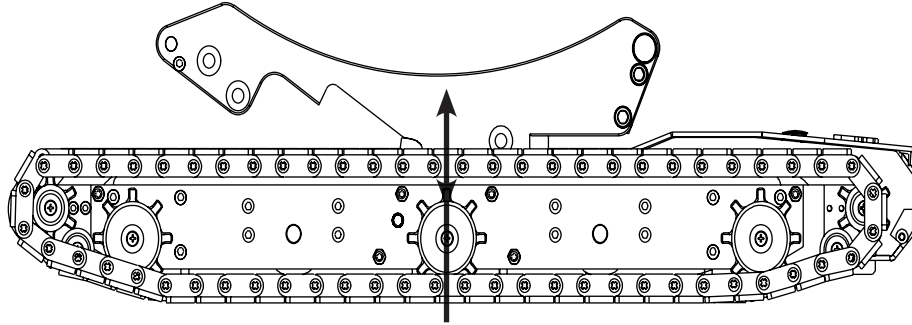

1/2" Up and Down Play at Center of Track

4. Tighten all 3 retainer screws and reinstall the plastic track covers

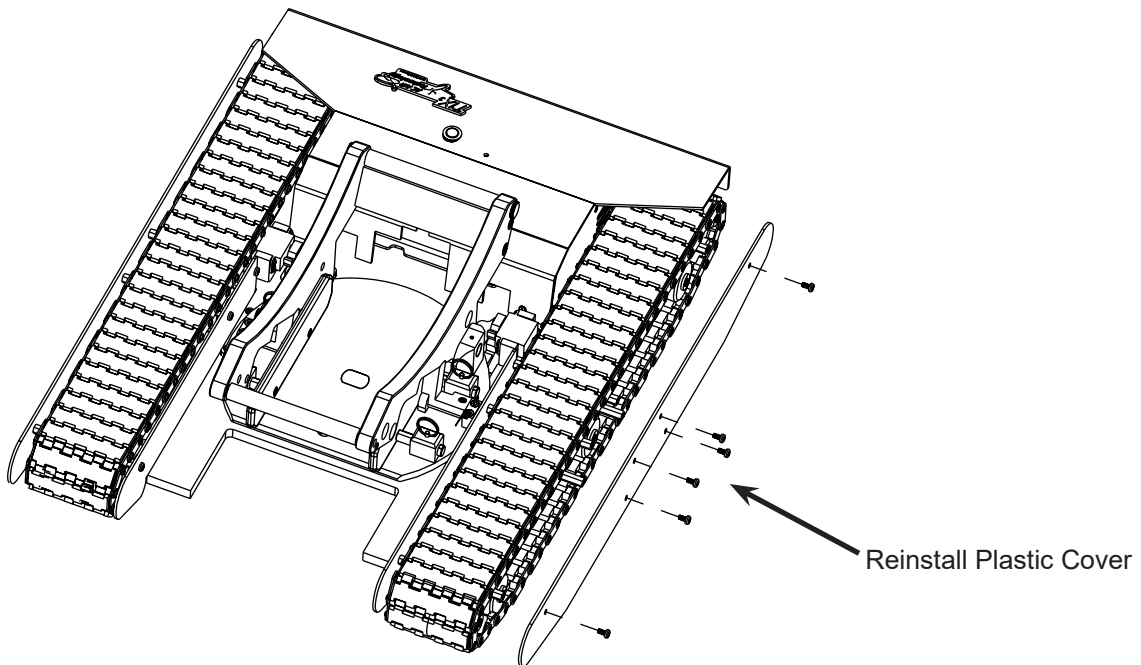

2. Start-Up Guide

2-8 Charging the Tug

1. Before charging your tug, the remote controller and tug should both be turned OFF.

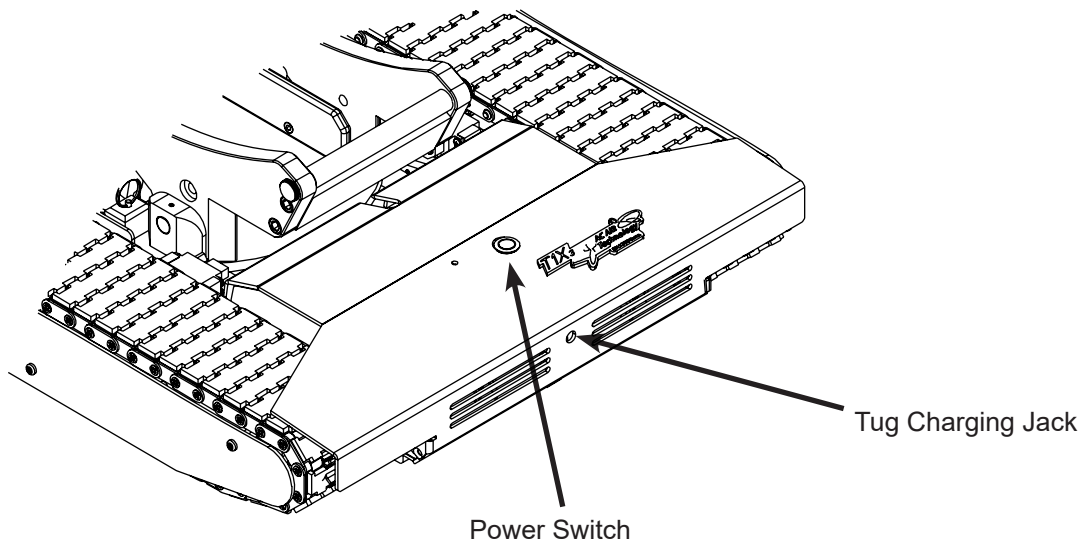

2. Plug charger into charging jack and into a wall socket. The plug can only be inserted in one direction.
3. If the charging indicator LED is:
 - Red.....Charging
 - Solid Green.....Fully Charged
 - Flashing Green.....No longer charging

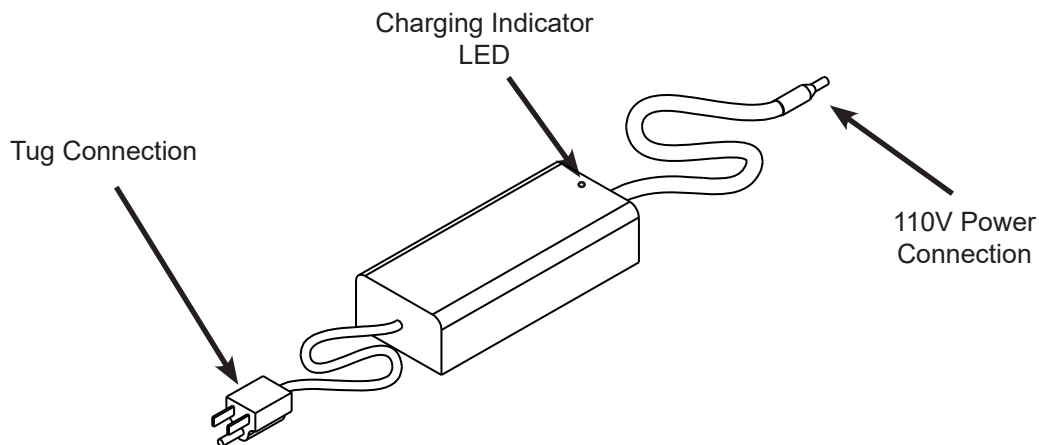

4. Leave the tug charging when it is not in use. The charger is equipped with “smart” charging technology, preventing the battery from overcharging. Keeping the tug on its charger this will prolong the life of the battery.

2. Start-Up Guide

2-9 Charging the Remote Control

WARNING: Only use the supplied charger to charge the controller when using the supplied batteries or the following:

- 1200mAh to 2200 mAh Ni-MH or Ni-Cd 'AA' Rechargeable Batteries

Using the remote control charger with alkaline batteries installed can damage the controller. Do not use the charger if alkaline batteries are installed in the controller.

1. Plug the transmitter charger into a 110v AC wall socket.
2. Plug the connector from the charger into the charging jack on the transmitter. The charging indicator LED, located on the side of the transmitter, will illuminate green indicating the charger is charging. Once the transmitter is fully charged the charging indicator LED will turn off.
3. The charging rate of the charger is 150mAh. When using the 1200mAh batteries that are supplied, the radio requires an 8 hour charge when fully discharged ($1200/150=8$). If using 2200mAh batteries, it will take approximately 15 hours to charge ($2200/150=14.6$).

It is recommended to leave the remote controller charging when not in use.

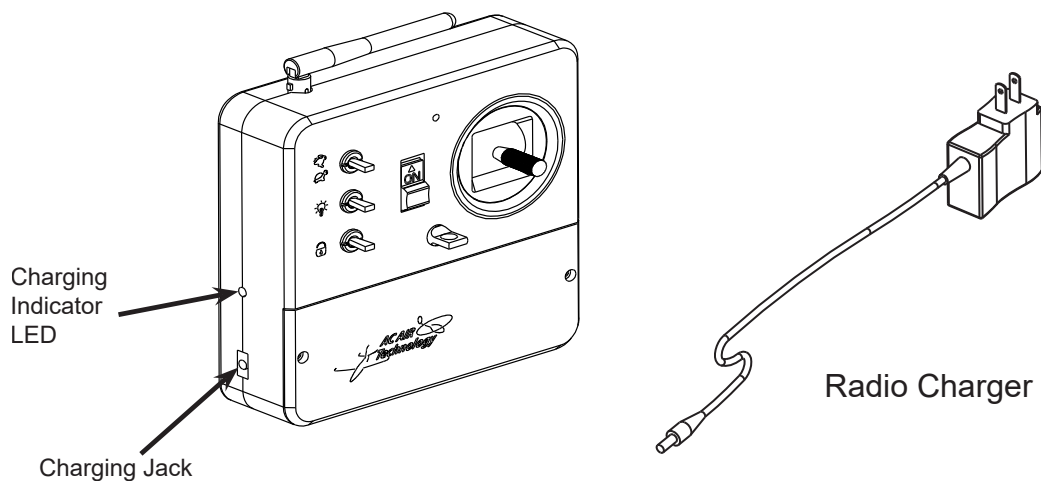

2. Start-Up Guide

2-10 Replacing Remote Control Batteries

1. Before changing the remote control batteries, the remote controller and tug should be turned OFF.
2. Remove 2 screws on the back cover of the remote controller then remove the back cover.

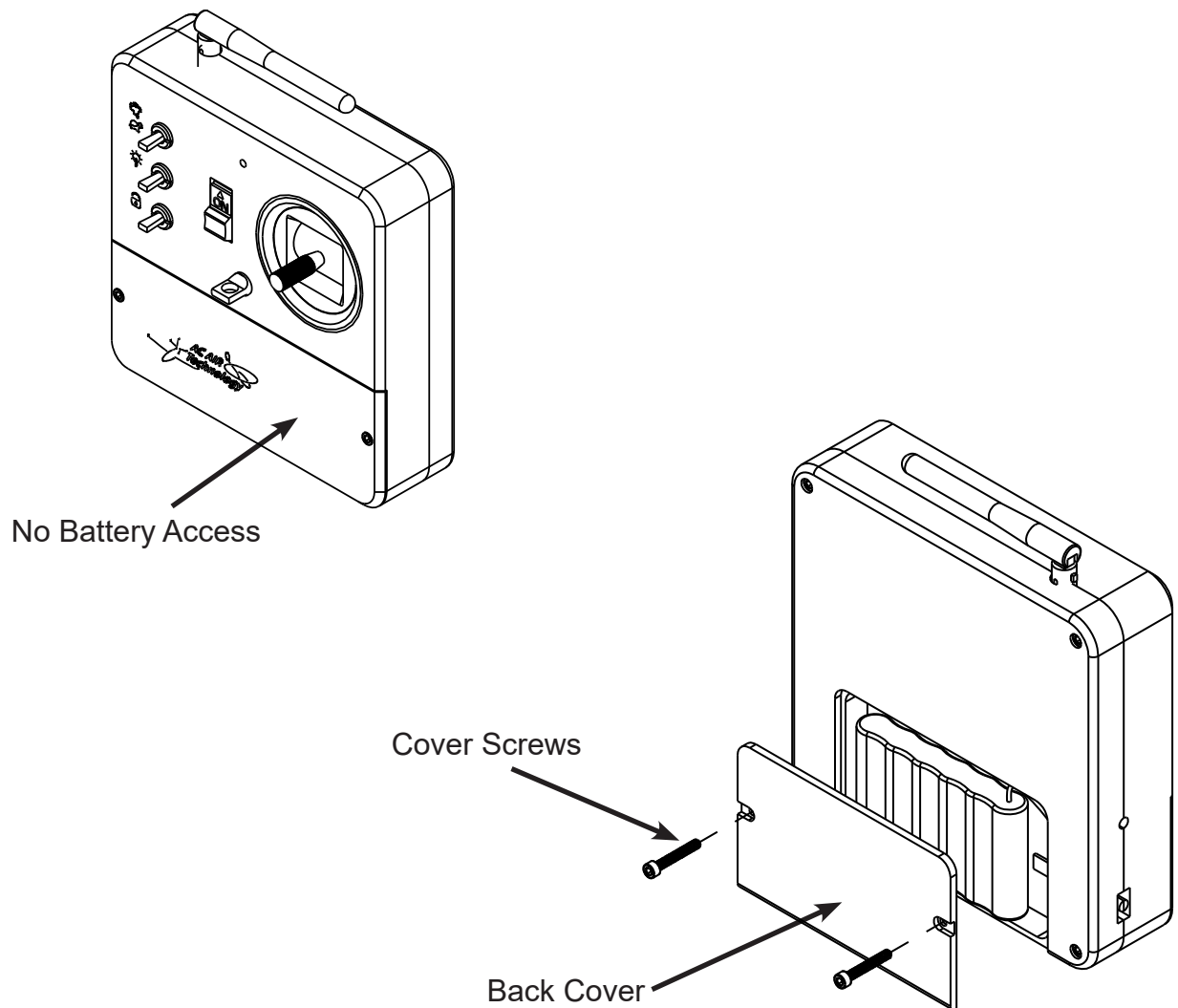

The transmitter batteries are set up like A or B shown below:

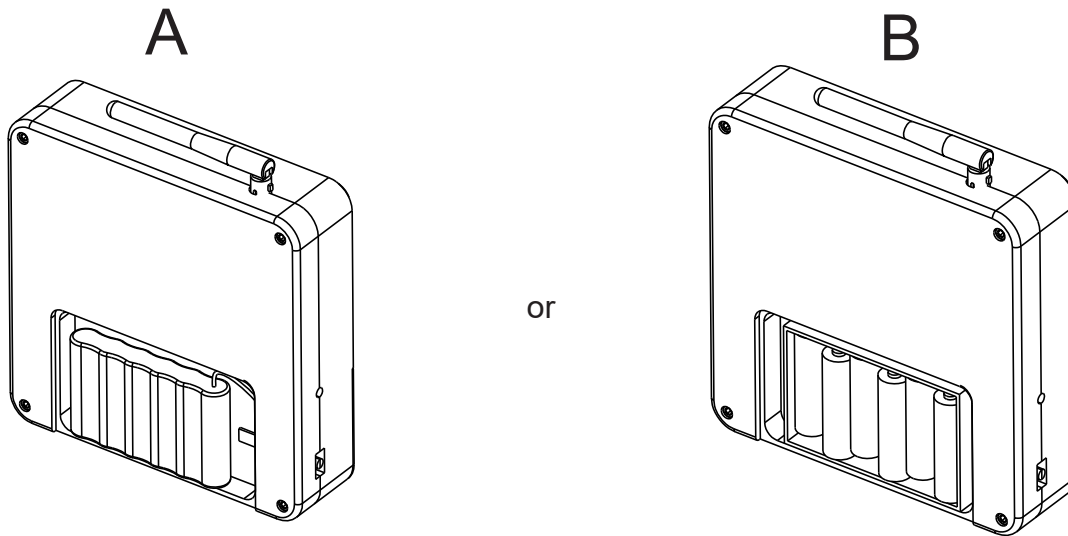

A. A shrink wrapped battery pack

3A. Disconnect the shrink wrapped battery pack and remove the battery.

4A. Replace the batteries by purchasing a new shrink wrapped battery pack from AC Air Technology or installing the supplied battery tray and purchasing 6 rechargeable 'AA' Lithium Ion batteries. Refer to section 2-9 in the owners manual

5A. Reconnect the battery to the transmitter circuit board.

6A. Re-install back cover and screws.

B. A battery tray with 6 rechargeable 'AA' Lithium Ion batteries

3B. Remove the 6 batteries and replace with new rechargeable 'AA' Lithium Ion batteries. Refer to section 2-9 in the owners manual.

Note: A shrink wrapped battery pack can be purchased from AC Air Technology to replace the installed battery tray. To use a shrink wrapped battery pack:

1. Disconnect the battery tray from the transmitter circuit board.
2. Connect the new shrink wrapped battery pack to the circuit board.

4B. Re-install back cover and screws.

Battery Tray

Located inside the remote control box

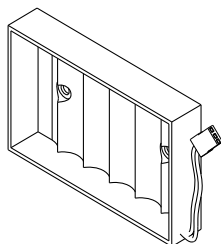

3. Troubleshooting

The troubleshooting guide is divided into three sections: Tug, Remote Controller, Wheel Cradle. Refer to the images and descriptions below as they are mentioned throughout the text.

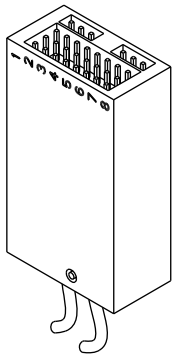

Radio Receiver

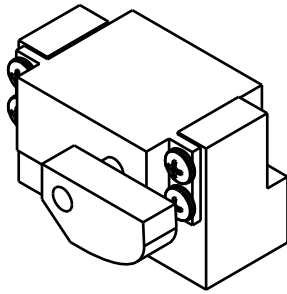

Servo

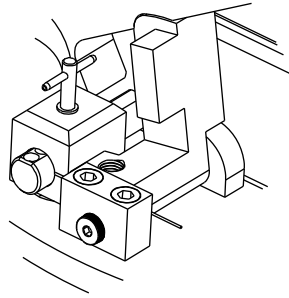

Latch Mechanism

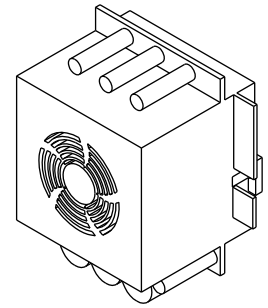

Speed Control

Tug			
Symptom	Cause	Action	Detail
Tug beeps 3 times	Tug is ON	No action required	Tug will beep when initially turned on
	Battery voltage is getting low	Charge tug battery	Tug charger indicator light will illuminate red when charging and green when fully charged. Tug will beep when the battery voltage is below 28 volts (power button flashing red). It is recommended to keep the tug and remote controller charging when not in use .
	Tug is momentarily overloaded	Turn the tug power button OFF then ON again to reset the PC Board.	Steep inclines, turning the tug underneath the wheel without any forward/backward motion, and sudden stops can cause the tug to signal a momentary overload.
Tug beeps continuously	Battery voltage is below operable voltage	Charge tug battery or Replace battery if it does not hold a charge. With a voltmeter, check tug charger output voltage for 29.4 volts. Replace charger if it does not output the correct voltage	Tug power button light will blink red. Tug charger indicator light will illuminate red when charging and green when fully charged. It is recommended to keep the tug and remote controller charging when not in use .
Tug indicates a full charge soon after it is plugged into the charger	Charger has failed	Replace tug charger	Tug charger indicator light will illuminate red when charging, green when fully charged, and flash green when no longer charging.
Tug does not turn on	Battery is dead	Turn off the remote controller and tug. Open the magnetic tug cover and plug the battery into the PC board. Ensure the connection is fully engaged.	
	Battery is not plugged into the PC Board	Turn off the remote controller and tug. Open the magnetic tug cover and plug the battery into the PC board. Ensure the connection is fully engaged.	During shipping the battery connection can become loose or disengage from the PC board.
	Battery voltage is below operable voltage	Charge tug battery or Replace battery if it does not hold a charge. With a voltmeter, check tug charger output voltage for 29.4 volts. Replace charger if it does not output the correct voltage	Tug charger indicator light will illuminate red when charging and green when fully charged. It is recommended to keep the tug and remote controller charging when not in use .
	Main board 5- or 10-Amp fuse is blown.	Replace the 5- or 10-amp fuse.	The provided spare parts kit comes with extra fuses. It includes a 4 or 2-amp fuse (lights) and 5 or 10-amp fuse (main board). These are common fuses that can be found at most auto parts stores. Disconnect the battery when

	The tug turns on only when on the charger not on battery power.		working on or around the PC board to prevent a short circuit.
Tug beeps 3 times then powers off	PC board circuit breaker button is activated and the breaker connection to the main board is loose. Tug will not turn on with the charger connected.	Tighten the 2 screws underneath the circuit breaker, this requires removing the main board to gain access to the connection	Call or email tech support for further assistance
	PC board circuit breaker is damaged		The tug power button light and the PC board voltmeter will still function.
Tug does not respond to remote controller	Battery is low on remote controller or tug	Charge the battery on remote controller or tug	Tug charger indicator light will illuminate red when charging and green when fully charged. Remote controller charging indicator light, located on the side of the remote, will illuminate green when charging and light will turn off then fully charged. It is recommended to keep the tug and remote controller charging when not in use .
	Tug is overloaded	Reset the circuit breaker(s). Turn off the remote controller and tug. Open the magnetic tug cover and locate the circuit breaker(s) on the PC board. Press the button(s) down to deactivate the circuit breaker (If it is active, you will feel resistance from the button). See the critical note in the "Details" section.	Steep inclines, towing above the tug's capacity, and sudden stops can cause the tug to activate the circuit breaker. CRITICAL NOTE: If the circuit breaker continues to activate after it is reset, the tug is overstressed and could cause damage to the circuit board. Address any mechanical issues, such as a seized sprocket or missing track retainer clips or any driving conditions, such as driving up a steep incline or towing above the tug's capacity that could cause the tug to overstress. If the issue persists, call or email AC Air Technology tech support for further assistance.
	Remote controller and receiver are not binding	Rebind remote controller and receiver.	Call or email tech support for further assistance
One track turns but the other track does not	Speed controls are not plugged into radio receiver correctly	Turn off the radio controller and tug. Open the magnetic tug cover. Visually inspect the wire from the speed control to the receiver on the PC board for any damage. If there is damage, replace the speed controls. Verify that the wires from the speed controls are connected to slot numbers 1 and 2 on the receiver. Ensure the connections are fully engaged	If there is damage to the speed controls, the PC board may need to be replaced. Call tech support for further assistance.

	Gearbox failure	Open the tug cover and visually inspect the motors for any obstruction. With the radio off, carefully clear any obstruction. With the cover open, radio on, visually check if the motor(s) are turning. If the motor(s) are turning and there is a grinding noise, the gearbox needs repair.	Call or email tech support for further assistance
	For T-Mini Tugs Only: The press-fit motor pinion has slipped off the shaft. Motor turns smoothly by hand with no grinding noise coming from the gearbox.	Replace the pinion and press-fit it to your existing motor. Or Purchase a new pinion and motor assembly	Call or email tech support for further assistance
Tug operating sluggish/ low power	Tug is being operated on LOW or MEDIUM Speed.	Switch speed setting on remote controller to HI speed. (Rabbit Icon)	HI speed mode enables the tug's full power. It is recommended to use the tug in HI speed mode when operating outside, in an open area. LOW and MEDIUM speed modes are helpful when operating in small quarters for precise positioning.
Remote Controller			
Symptom	Cause	Action	Detail
Remote controller is beeping	Battery is low	Charge remote control. or replace remote controller batteries	See owner's manual section "Replacing Transmitter Batteries" for details. It is recommended to keep the tug and remote controller charging when not in use
Remote controller does not turn ON	Battery voltage is below operable voltage	Charge remote control. or replace remote controller batteries	See owner's manual section "Replacing Transmitter Batteries" for details. It is recommended to keep the tug and remote controller charging when not in use
Remote controller indicates a full charge soon after it is plugged into the charger	Charger has failed	Replace remote controller charger	The remote controller LED on the left side of the controller, just above the charging port, will illuminate green to indicate it is charging. The green will turn OFF once it is fully charged.
Remote Controller short beep, long-beep sound, tug is ON but the does not respond to	Joystick connection is loose	With the controller off, remove the remote-control battery cover on the back of the controller and disconnect the battery. Then remove the antenna and loosen the 8mm antenna nut. Remove	Do not forget to reconnect the remote-control battery.

remote controller		remote control <i>back</i> cover which is held on with 4 screws. Disconnect and reconnect the joystick.	
	Joystick needs to be recalibrated	To verify the issue, remove remote control <i>front</i> cover which is held on with 2 screws. Turn the remote off, then back on <i>without</i> moving the joystick, the screen will read "Throttle Warning"	Call or email tech support for further assistance

Wheel Cradle

Symptom	Cause	Action	Detail
Unable to release the cradle	Not enough pressure on the wheel cradle back gate	Apply pressure with the tug and remote controller onto the back gate to relieve pressure on the latch mechanism.	If pressure is applied to the loading end of the cradle, away from the latch mechanism, it will cause the latch to bind and not release.
	Servo is not plugged in	Turn off the remote controller and tug. Open the magnetic tug cover. The servo is located next to latch mechanism, follow the wire to the radio receiver, located on the PC Board, and verify it is connected to slot number 6 on the radio receiver. Ensure the connection is fully engaged	
	Servo failure	Visually inspect the servo located next to the latch mechanism. Press the release button on the remote control, if no sound or motion is coming from the servo, the servo needs to be replaced	
	Latch is bound	Visually inspect the latch mechanism. Press the release button on the remote controller. If the cam, located on the servo next to the latch mechanism, turns but the latch does not disengage, service or replace latch assembly.	Call or email tech support for further assistance

4. Warranty

LIMITED WARRANTY

Your new AC Air Technology Tug is warranted to the original purchaser (only) for one full year from the date of purchase to be free from factory defects in material and workmanship. During this 12-month period, AC Air Technology will repair or replace, at our discretion, the defective component determined by AC Air Technology to be defective.

This warranty does not apply to damage or defect resulting from misuse, improper application, commercial use, or attempted repair by “non-AC Air Technology” service staff. The warranty does not cover shipping or handling cost or any incidental or consequential damage. Batteries and tracks are not covered by warranty.

DAMAGE LIMITS

AC Air Technology shall not be liable for any damage, indirect or consequential, loss of profits or commercial or production loss, or other special loss or damage in any way connected with this product regardless whether such claim is based on warranty, in contract, negligence, or strict liability. In no event shall the liability of AC Air Technology exceed the individual price of the product on which liability is asserted. AC Air Technology has no control of the set up, application, use, modification, or misuse of this product, thus no liability shall be assumed or accepted for any resulting damage or injury. By the first act of use, set up or assembly, the user in using the product accepts all resulting liability. Failure to operate this product in a safe and responsible manner can result in damage or injury, both to the user as well as to others, the product, or property. This product is not a toy and is NOT intended to be used by children without adult supervision. It is essential to read the entire manual and warranty/liability information prior to first use/application/installation of this product to operate correctly and avoid damage/injury,

In cases where the purchaser or user are not prepared to accept liability associated with the use of this product, the user or purchaser is advised to return the unused product immediately in unused condition to the place of purchase.

RETURN PROCEDURE

When sending equipment in for requested warranty service, please include a note describing the problems/concerns with the equipment. You must include your name, address, telephone number and e-mail for prompt service. To request warranty service, a copy of your original sales receipt must be included. Warranty is approved and performed at the discretion of AC Air Technology service department. You are required to pay all postage, shipping and insurance charges.

RETURN POLICY

Products can be returned within 10 days of delivery for a full refund if the product is in new condition and shipped with all the original packing and accessories. Any shipping cost associated with product delivery and/or return will not be refunded. A return authorization must be requested from AC Air Technology before any products can be returned.